



FCC TEST REPORT

REPORT NO.: RF131118E02
MODEL NO.: DT8050A, DT8050M
FCC ID: 2ABC8-PP300850SE
RECEIVED: Nov. 18, 2013
TESTED: Nov. 19 to 22, 2013
ISSUED: Dec. 16, 2013

APPLICANT: Honeywell Security Sensor CoE

ADDRESS: 38F, Block A of Galaxy Century Building,
No.3069 Caitian Road, Fu Tian District,
Shenzhen, China

ISSUED BY: Bureau Veritas Consumer Products Services
(H.K.) Ltd., Taoyuan Branch

LAB ADDRESS : No. 81-1, Lu Liao Keng, 9th Ling,Wu Lung Tsuen,
Chiung Lin Hsiang, Hsin Chu Hsien 307, Taiwan

TEST LOCATION (1): No. 81-1, Lu Liao Keng, 9th Ling,Wu Lung Tsuen,
Chiung Lin Hsiang, Hsin Chu Hsien 307, Taiwan

TEST LOCATION (2): No. 49, Ln. 206, Wende Rd., Shangshan Tsuen,
Chiung Lin Hsiang, Hsin Chu Hsien 307, Taiwan

This report should not be used by the client to claim product certification, approval, or endorsement by TAF or any government agencies.



This report is for your exclusive use. Any copying or replication of this report to or for any other person or entity, or use of our name or trademark, is permitted only with our prior written permission. This report sets forth our findings solely with respect to the test samples identified herein. The results set forth in this report are not indicative or representative of the quality or characteristics of the lot from which a test sample was taken or any similar or identical product unless specifically and expressly noted. Our report includes all of the tests requested by you and the results thereof based upon the information that you provided to us. You have 60 days from date of issuance of this report to notify us of any material error or omission caused by our negligence, provided, however, that such notice shall be in writing and shall specifically address the issue you wish to raise. A failure to raise such issue within the prescribed time shall constitute your unqualified acceptance of the completeness of this report, the tests conducted and the correctness of the report contents. Unless specific mention, the uncertainty of measurement has been explicitly taken into account to declare the compliance or non-compliance to the specification



Table of Contents

RELEASE CONTROL RECORD	3
1 CERTIFICATION.....	4
2 SUMMARY OF TEST RESULTS	5
2.1 MEASUREMENT UNCERTAINTY.....	5
3 GENERAL INFORMATION	6
3.1 GENERAL DESCRIPTION OF EUT	6
3.2 DESCRIPTION OF TEST MODES	7
3.3 TEST MODE APPLICABILITY AND TESTED CHANNEL DETAIL.....	7
3.4 GENERAL DESCRIPTION OF APPLIED STANDARDS.....	9
3.5 DESCRIPTION OF SUPPORT UNITS	10
3.6 CONFIGURATION OF SYSTEM UNDER TEST.....	11
4 TEST PROCEDURES AND RESULTS.....	12
4.1 CONDUCTED EMISSION MEASUREMENT.....	12
4.1.1 LIMITS OF CONDUCTED EMISSION MEASUREMENT	12
4.1.2 TEST INSTRUMENTS.....	12
4.1.3 TEST PROCEDURES	13
4.1.4 DEVIATION FROM TEST STANDARD.....	13
4.1.5 TEST SETUP.....	13
4.1.6 EUT OPERATING CONDITIONS	14
4.1.7 TEST RESULTS (MODE 1)	15
4.1.8 TEST RESULTS (MODE 2)	17
4.2 RADIATED EMISSION AND BANDEDGE MEASUREMENT	19
4.2.1 LIMITS OF RADIATED EMISSION AND BANDEDGE MEASUREMENT	19
4.2.2 TEST INSTRUMENTS.....	20
4.2.3 TEST PROCEDURES	21
4.2.4 DEVIATION FROM TEST STANDARD.....	22
4.2.5 TEST SETUP.....	23
4.2.6 EUT OPERATING CONDITIONS	23
4.2.7 TEST RESULTS (MODE 1)	24
4.2.8 TEST RESULTS (MODE 2)	27
4.3 BANDEDGE MEASUREMENT.....	28
4.3.1 LIMITS OF BANDEDGE	28
4.3.2 TEST INSTRUMENTS.....	28
4.3.3 TEST PROCEDURE.....	28
4.3.4 DEVIATION FROM TEST STANDARD.....	28
4.3.5 EUT OPERATING CONDITION.....	28
4.3.6 TEST RESULTS	29
5 PHOTOGRAPHS OF THE TEST CONFIGURATION	31
6 INFORMATION ON THE TESTING LABORATORIES.....	32
7 APPENDIX A - MODIFICATIONS RECORDERS FOR ENGINEERING CHANGES TO THE EUT BY THE LAB.....	33



A D T

RELEASE CONTROL RECORD

ISSUE NO.	REASON FOR CHANGE	DATE ISSUED
RF131118E02	Original release	Dec. 16, 2013



1 CERTIFICATION

PRODUCT : DUAL TEC Motion Sensor
BRAND NAME : Honeywell
MODEL NO. : DT8050A, DT8050M
TEST SAMPLE : ENGINEERING SAMPLE
APPLICANT : Honeywell Security Sensor CoE
TESTED : Nov. 19 to 22, 2013
STANDARDS : FCC Part 15, Subpart C (Section 15.245)
ANSI C63.10-2009

The above equipment (Model: DT8050A) has been tested by **Bureau Veritas Consumer Products Services (H.K.) Ltd., Taoyuan Branch**, and found compliance with the requirement of the above standards. The test record, data evaluation & Equipment Under Test (EUT) configurations represented herein are true and accurate accounts of the measurements of the sample's EMC characteristics under the conditions specified in this report.

PREPARED BY :  , **DATE:** Dec. 16, 2013
(Lori Chung, Specialist)

APPROVED BY :  , **DATE:** Dec. 16, 2013
(May Chen, Manager)

2 SUMMARY OF TEST RESULTS

The EUT has been tested according to the following specifications:

APPLIED STANDARD: 47 CFR Part 15, Subpart C			
Standard Paragraph	Test Type	Result	Remark
15.207	Conducted Emission Test	PASS	Minimum passing margin is -15.03dB at 0.16422MHz.
15.245	Radiated Emission Test	PASS	Minimum passing margin is -2.4dB at 10500MHz
15.215 (c)	Bandedge Measurement	PASS	Meet the requirement of limit
15.203	Antenna Requirement	PASS	No antenna connector is used.

2.1 MEASUREMENT UNCERTAINTY

Where relevant, the following measurement uncertainty levels have been estimated for tests performed on the EUT as specified in CISPR 16-4-2:

This uncertainty represents an expanded uncertainty expressed at approximately the 95% confidence level using a coverage factor of $k=2$.

Measurement	Value
Conducted emissions	2.98 dB
Radiated emissions (30MHz-1GHz)	5.46 dB
Radiated emissions (1GHz -6GHz)	3.73 dB
Radiated emissions (6GHz -18GHz)	3.90 dB
Radiated emissions (18GHz -40GHz)	4.11 dB

3 GENERAL INFORMATION

3.1 GENERAL DESCRIPTION OF EUT

PRODUCT	DUAL TEC Motion Sensor
MODEL NO.	DT8050A, DT8050M
POWER SUPPLY	DC 12V from power supply
MODULATION TYPE	GFSK
CARRIER FREQUENCY	10.525GHz
NUMBER OF CHANNEL	1
ANTENNA TYPE	Integral PCB antenna with 7dBi gain
DATA CABLE	NA
I/O PORTS	Refer to user's manual
ASSOCIATED DEVICES	NA

NOTE:

1. The EUT have two model names, which are identical to each other in all aspects except for the following table:

Brand	Model No.	Difference
Honeywell	DT8050A	-
	DT8050M	Remove AM feature base on DT8050A

From the above models, model: DT8050A was selected as representative model for radiated emission above 1GHz test.

2. DUAL TEC Motion Sensor is a 10.525GHz device that is applying Doppler radar phenomenon to sense motion. It transmits a low power microwave and receives energy reflected by objects.
3. The above EUT information was declared by the manufacturer and for more detailed features description, please refer to the manufacturer's specifications or User's Manual.

3.2 DESCRIPTION OF TEST MODES

1 channel is provided in this EUT.

Channel	Freq. (GHz)
1	10.525

3.3 TEST MODE APPLICABILITY AND TESTED CHANNEL DETAIL

EUT CONFIGURE MODE	APPLICABLE TO				DESCRIPTION
	PLC	RE < 1G	RE ≥ 1G	BE	
1	√	√	√	√	Model No.: DT8050A
2	√	√	-	-	Model No.: DT8050M

Where **PLC**: Power Line Conducted Emission

RE < 1G: Radiated Emission below 1GHz

RE ≥ 1G: Radiated Emission above 1GHz

BE: Bandedge Emission Measurement

Power Line Conducted Emission Test:

- Pre-Scan has been conducted to determine the worst-case mode from all possible combinations between available modulations, data rates and antenna ports (if EUT with antenna diversity architecture).
- Following channel(s) was (were) selected for the final test as listed below.

AVAILABLE CHANNEL	TESTED CHANNEL	MODULATION TYPE
1	1	GFSK

RADIATED EMISSION TEST (BELOW 1 GHz):

- Pre-Scan has been conducted to determine the worst-case mode from all possible combinations between available modulations, data rates and antenna ports (if EUT with antenna diversity architecture).
- Following channel(s) was (were) selected for the final test as listed below.

AVAILABLE CHANNEL	TESTED CHANNEL	MODULATION TYPE
1	1	GFSK

RADIATED EMISSION TEST (ABOVE 1 GHz):

- Pre-Scan has been conducted to determine the worst-case mode from all possible combinations between available modulations, data rates and antenna ports (if EUT with antenna diversity architecture).
- Following channel(s) was (were) selected for the final test as listed below.

AVAILABLE CHANNEL	TESTED CHANNEL	MODULATION TYPE
1	1	GFSK

BANDEDGE EMISSION MEASUREMENT:

- Pre-Scan has been conducted to determine the worst-case mode from all possible combinations between available modulations, data rates and antenna ports (if EUT with antenna diversity architecture).
- Following channel(s) was (were) selected for the final test as listed below.

AVAILABLE CHANNEL	TESTED CHANNEL	MODULATION TYPE
1	1	GFSK

TEST CONDITION:

APPLICABLE TO	ENVIRONMENTAL CONDITIONS	INPUT POWER	TESTED BY
PLC	24deg. C, 65%RH	120Vac, 60Hz (SYSTEM)	Jyunchun Lin
RE<1G	21deg. C, 71%RH	DC 12V	Andy Ho
RE≥1G	21deg. C, 69%RH 22deg. C, 68%RH	DC 12V	Robert Cheng
BE	25deg. C, 60%RH	DC 12V	Robert Cheng



3.4 GENERAL DESCRIPTION OF APPLIED STANDARDS

The EUT is a RF product. According to the specifications of the manufacturer, it must comply with the requirements of the following standards:

FCC Part 15, Subpart C (Section 15.245)
ANSI C63.10: 2009

All tests have been performed and recorded as per the above standards.

3.5 DESCRIPTION OF SUPPORT UNITS

The EUT has been tested as an independent unit together with other necessary accessories or support units. The following support units or accessories were used to form a representative test configuration during the tests.

NO.	PRODUCT	BRAND	MODEL NO.	SERIAL NO.	FCC ID
1	DC POWER SUPPLY	Topward	6603D	795558	NA

NO.	SIGNAL CABLE DESCRIPTION OF THE ABOVE SUPPORT UNITS
1	DC cable (1.1m) / DC cable (1.1m)

NOTE: All power cords of the above support units are non shielded (1.8m).

3.6 CONFIGURATION OF SYSTEM UNDER TEST

For conducted test:

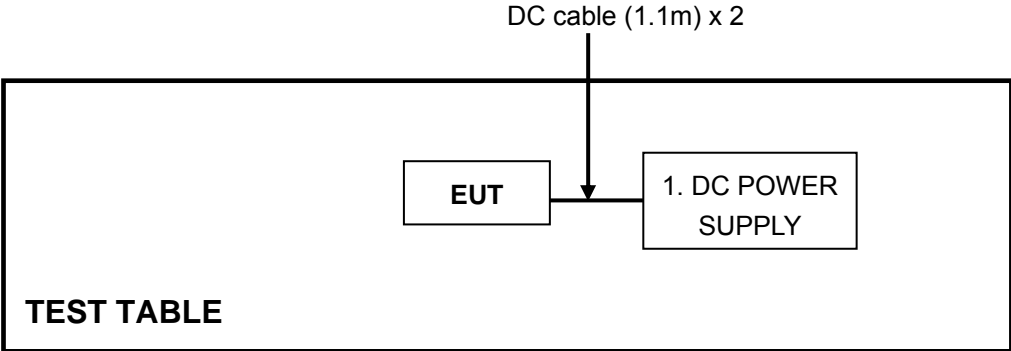

For other test items:

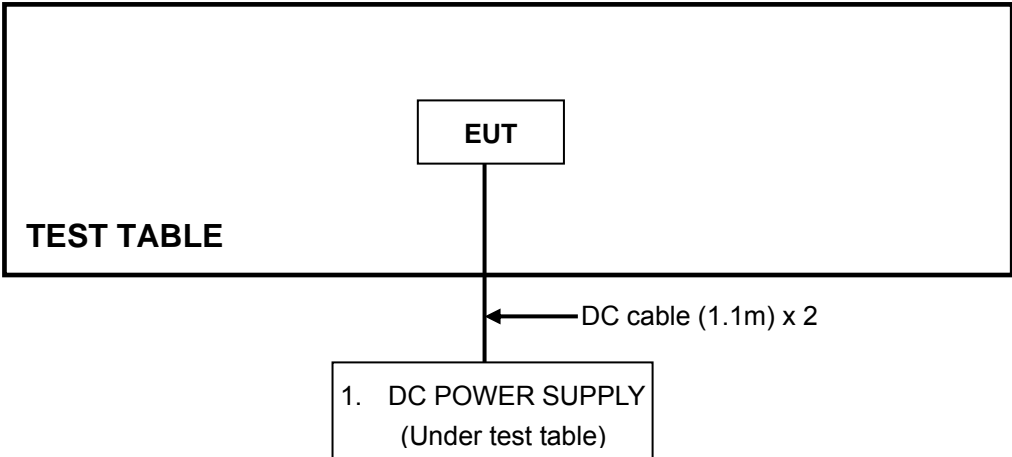

4 TEST PROCEDURES AND RESULTS

4.1 CONDUCTED EMISSION MEASUREMENT

4.1.1 LIMITS OF CONDUCTED EMISSION MEASUREMENT

FREQUENCY OF EMISSION (MHz)	CONDUCTED LIMIT (dBµV)	
	Quasi-peak	Average
0.15-0.5	66 to 56	56 to 46
0.5-5	56	46
5-30	60	50

- NOTE:**
1. The lower limit shall apply at the transition frequencies.
 2. The limit decreases in line with the logarithm of the frequency in the range of 0.15 to 0.50 MHz.

4.1.2 TEST INSTRUMENTS

DESCRIPTION & MANUFACTURER	MODEL NO.	SERIAL NO.	CALIBRATED DATE	CALIBRATED UNTIL
Test Receiver ROHDE & SCHWARZ	ESCS 30	100287	Feb. 28, 2013	Feb. 27, 2014
Line-Impedance Stabilization Network (for EUT) ROHDE & SCHWARZ	NSLK-8127	5127-523	Oct. 02, 2013	Oct. 01, 2014
Line-Impedance Stabilization Network (for Peripheral) ROHDE & SCHWARZ	ENV216	100071	Nov. 13, 2013	Nov. 12, 2014
RF Cable (JYEBAO)	5DFB	COACAB-001	May 27, 2013	May 26, 2014
50 ohms Terminator	50	3	Oct. 17, 2013	Oct. 16, 2014
50 ohms Terminator	N/A	EMC-04	Oct. 17, 2013	Oct. 16, 2014
Software ADT	BV ADT_Cond_V7.3.7 .3	NA	NA	NA

Note:

1. The calibration interval of the above test instruments is 12 months and the calibrations are traceable to NML/ROC and NIST/USA.
2. The test was performed in Shielded Room No. A.
- 3 The VCCI Con A Registration No. is C-817.
4. Tested Date: Nov. 22, 2013

4.1.3 TEST PROCEDURES

- a. The EUT was placed 0.4 meters from the conducting wall of the shielded room with EUT being connected to the power mains through a line impedance stabilization network (LISN). Other support units were connected to the power mains through another LISN.
- b. The two LISNs provide 50 ohm/ 50uH of coupling impedance for the measuring instrument.
- c. Both lines of the power mains connected to the EUT were checked for maximum conducted interference.
- d. The frequency range from 150kHz to 30MHz was searched. Emission levels under (Limit - 20dB) were not recorded.

NOTE:

1. The resolution bandwidth of test receiver is 9kHz for Quasi-peak detection (QP) & Average detection (AV).

4.1.4 DEVIATION FROM TEST STANDARD

No deviation

4.1.5 TEST SETUP

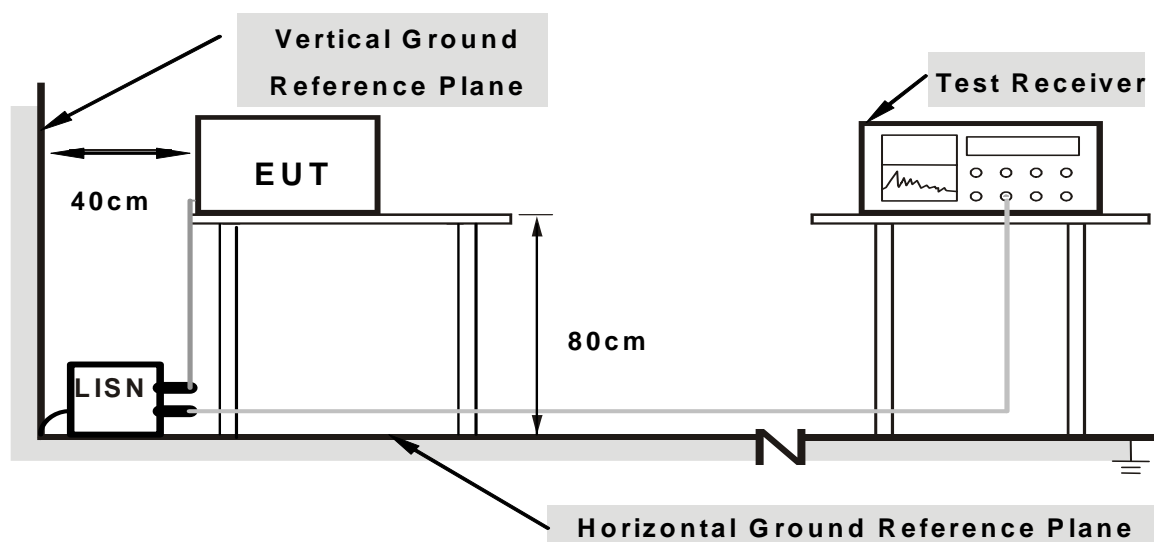

Note: 1. Support units were connected to second LISN.

For the actual test configuration, please refer to the related item – Photographs of the Test Configuration.



4.1.6 EUT OPERATING CONDITIONS

Set the EUT under transmission / receiver condition continuously at specific channel frequency.

4.1.7 TEST RESULTS (MODE 1)

PHASE	Line (L)	DETECTOR FUNCTION	Quasi-Peak (QP) / Average (AV)
-------	----------	-------------------	--------------------------------

No	Freq.	Corr.	Reading Value		Emission Level		Limit		Margin	
	[MHz]	Factor	[dB (uV)]		[dB (uV)]		[dB (uV)]		(dB)	
		(dB)	Q.P.	AV.	Q.P.	AV.	Q.P.	AV.	Q.P.	AV.
1	0.16387	0.05	40.15	39.25	40.20	39.30	65.27	55.27	-25.06	-15.96
2	0.23006	0.07	18.06	5.74	18.13	5.81	62.45	52.45	-44.32	-46.64
3	0.29278	0.08	16.01	5.00	16.09	5.08	60.45	50.45	-44.35	-45.36
4	0.59141	0.12	20.97	12.97	21.09	13.09	56.00	46.00	-34.91	-32.91
5	0.96641	0.13	17.26	7.71	17.39	7.84	56.00	46.00	-38.61	-38.16
6	2.26169	0.19	10.68	4.74	10.87	4.93	56.00	46.00	-45.13	-41.07

REMARKS:

1. Q.P. and AV. are abbreviations of quasi-peak and average individually.
2. The emission levels of other frequencies were very low against the limit.
3. Margin value = Emission level - Limit value
4. Correction factor = Insertion loss + Cable loss
5. Emission Level = Correction Factor + Reading Value

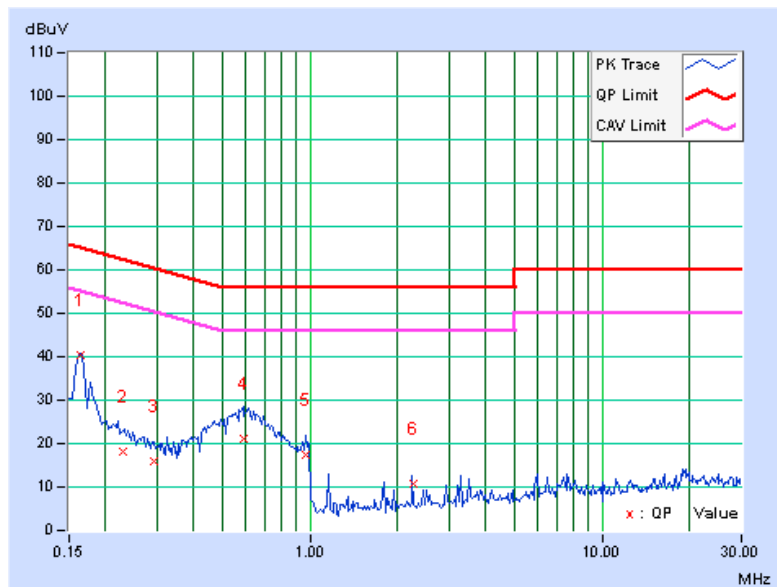



A D T

PHASE	Neutral (N)	DETECTOR FUNCTION	Quasi-Peak (QP) / Average (AV)
-------	-------------	-------------------	--------------------------------

No	Freq.	Corr.	Reading Value		Emission Level		Limit		Margin	
	[MHz]	Factor	[dB (uV)]		[dB (uV)]		[dB (uV)]		(dB)	
		(dB)	Q.P.	AV.	Q.P.	AV.	Q.P.	AV.	Q.P.	AV.
1	0.16397	0.05	40.39	39.45	40.44	39.50	65.26	55.26	-24.82	-15.76
2	0.39219	0.11	16.27	5.37	16.38	5.48	58.02	48.02	-41.64	-42.54
3	0.59141	0.12	22.09	14.79	22.21	14.91	56.00	46.00	-33.79	-31.09
4	0.77500	0.13	18.67	7.95	18.80	8.08	56.00	46.00	-37.20	-37.92
5	0.97031	0.14	16.74	6.23	16.88	6.37	56.00	46.00	-39.12	-39.63
6	2.46094	0.20	12.13	6.15	12.33	6.35	56.00	46.00	-43.67	-39.65

REMARKS:

1. Q.P. and AV. are abbreviations of quasi-peak and average individually.
2. The emission levels of other frequencies were very low against the limit.
3. Margin value = Emission level - Limit value
4. Correction factor = Insertion loss + Cable loss
5. Emission Level = Correction Factor + Reading Value

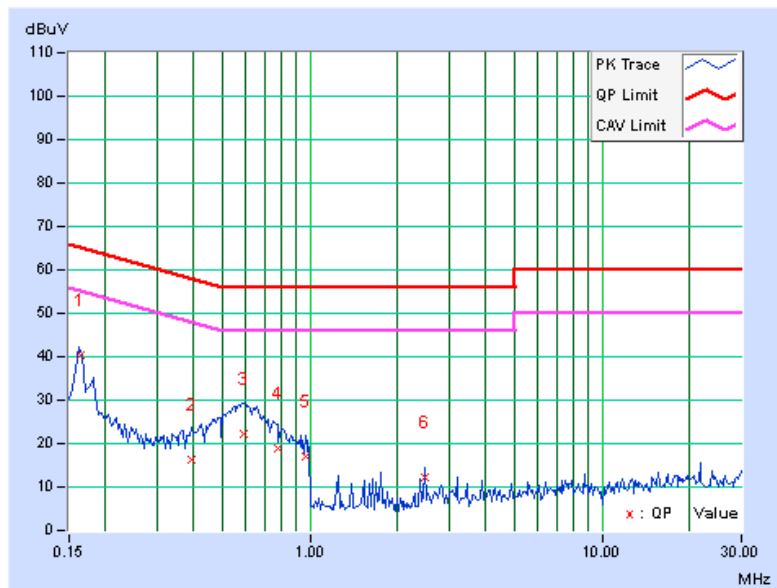

4.1.8 TEST RESULTS (MODE 2)

PHASE	Line (L)	DETECTOR FUNCTION	Quasi-Peak (QP) / Average (AV)
-------	----------	-------------------	--------------------------------

No	Freq.	Corr.	Reading Value		Emission Level		Limit		Margin	
	[MHz]	Factor	[dB (uV)]		[dB (uV)]		[dB (uV)]		(dB)	
		(dB)	Q.P.	AV.	Q.P.	AV.	Q.P.	AV.	Q.P.	AV.
1	0.16422	0.05	40.80	39.95	40.85	40.00	65.25	55.25	-24.39	-15.24
2	0.22812	0.07	18.44	8.74	18.51	8.81	62.52	52.52	-44.01	-43.71
3	0.44297	0.11	15.95	7.87	16.06	7.98	57.01	47.01	-40.94	-39.02
4	0.61875	0.12	21.77	13.21	21.89	13.33	56.00	46.00	-34.11	-32.67
5	1.24219	0.14	9.83	8.49	9.97	8.63	56.00	46.00	-46.03	-37.37
6	3.30469	0.28	8.97	7.45	9.25	7.73	56.00	46.00	-46.75	-38.27

REMARKS:

1. Q.P. and AV. are abbreviations of quasi-peak and average individually.
2. The emission levels of other frequencies were very low against the limit.
3. Margin value = Emission level - Limit value
4. Correction factor = Insertion loss + Cable loss
5. Emission Level = Correction Factor + Reading Value

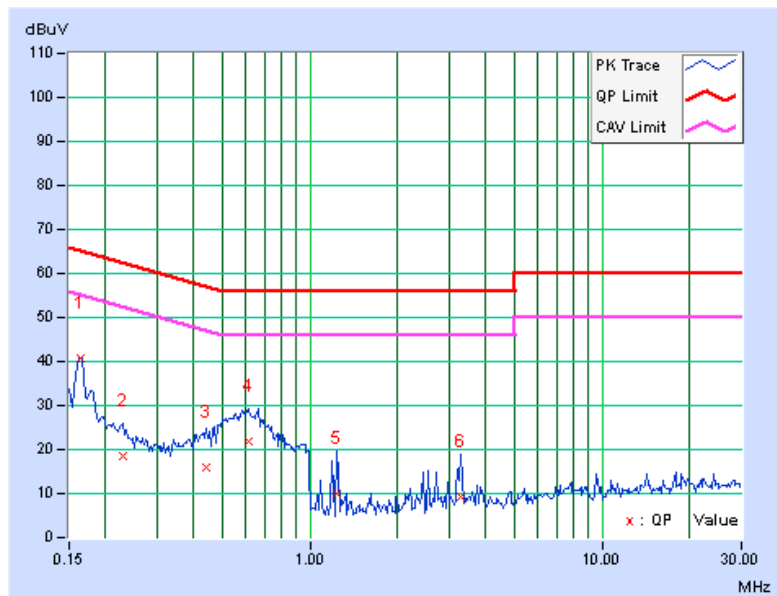



A D T

PHASE	Neutral (N)	DETECTOR FUNCTION	Quasi-Peak (QP) / Average (AV)
-------	-------------	-------------------	--------------------------------

No	Freq. [MHz]	Corr. Factor (dB)	Reading Value [dB (uV)]		Emission Level [dB (uV)]		Limit [dB (uV)]		Margin (dB)	
			Q.P.	AV.	Q.P.	AV.	Q.P.	AV.	Q.P.	AV.
			1	0.16297	0.05	41.00	39.89	41.05	39.94	65.31
2	0.23203	0.06	16.70	6.02	16.76	6.08	62.38	52.38	-45.62	-46.30
3	0.48984	0.11	19.05	12.53	19.16	12.64	56.17	46.17	-37.01	-33.53
4	0.65000	0.12	22.71	15.13	22.83	15.25	56.00	46.00	-33.17	-30.75
5	0.85313	0.13	15.54	7.19	15.67	7.32	56.00	46.00	-40.33	-38.68
6	3.37891	0.23	14.37	7.89	14.60	8.12	56.00	46.00	-41.40	-37.88

REMARKS:

1. Q.P. and AV. are abbreviations of quasi-peak and average individually.
2. The emission levels of other frequencies were very low against the limit.
3. Margin value = Emission level - Limit value
4. Correction factor = Insertion loss + Cable loss
5. Emission Level = Correction Factor + Reading Value

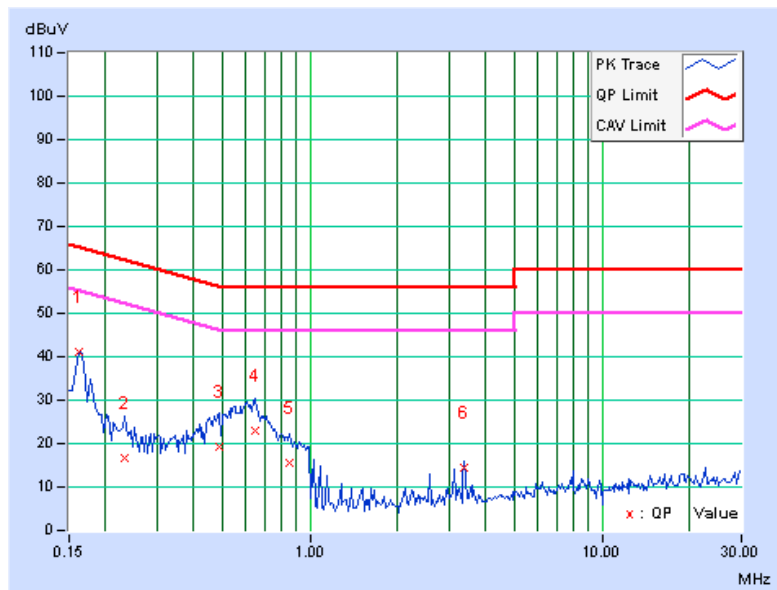

4.2 RADIATED EMISSION AND BANDEDGE MEASUREMENT

4.2.1 LIMITS OF RADIATED EMISSION AND BANDEDGE MEASUREMENT

According to 15.245 the field strength of emissions from intentional radiators operated under these frequencies bands shall not exceed the following:

Fundamental Frequency (MHz)	Field Strength of Fundamental (dBuV/m)	
	Peak	Average
10500 ~ 10550	148	128
	Field Strength of Harmonics (dBuV/m)	
	108	88

- (1) Field strength limits are specified at a distance of 3 meters.
- (2) Emissions radiated outside of the specified frequency bands, except for harmonics, shall be attenuated by at least 50 dB below the level of the fundamental or to the general radiated emission limits in Section 15.209, whichever is the lesser attenuation.

Emissions radiated outside of the specified bands, shall be according to the general radiated limits in 15.209 as following:

Frequencies (MHz)	Field strength (microvolts/meter)	Measurement distance (meters)
0.009-0.490	2400/F(kHz)	300
0.490-1.705	24000/F(kHz)	30
1.705-30.0	30	30
30-88	100	3
88-216	150	3
216-960	200	3
Above 960	500	3

NOTE:

1. As shown in 15.35(b), for frequencies above 1000MHz, the field strength limits are based on average detector, however, the peak field strength of any emission shall not exceed the maximum permitted average limits, specified above by more than 20dB under any condition of modulation.
2. Section 15.205 restricted bands of operation shall compliance with the limits in Section 15.209.

4.2.2 TEST INSTRUMENTS

FOR BELOW 1GHz TEST:

DESCRIPTION & MANUFACTURER	MODEL NO.	SERIAL NO.	CALIBRATED DATE	CALIBRATED UNTIL
MXE EMI Receiver Agilent	N9038A	MY50010156	Jan. 16, 2013	Jan. 15, 2014
Pre-Amplifier Mini-Circuits	ZFL-1000VH2 B	AMP-ZFL-04	Nov. 13, 2013	Nov. 12, 2014
Trilog Broadband Antenna SCHWARZBECK	VULB 9168	9168-361	Mar. 25, 2013	Mar. 24, 2014
RF Cable	NA	CHHCAB_001	Oct. 06, 2013	Oct. 05, 2014
Software	ADT_Radiated _V8.7.07	NA	NA	NA
Antenna Tower & Turn Table CT	NA	NA	NA	NA

Note:

1. The calibration interval of the above test instruments is 12 months and the calibrations are traceable to NML/ROC and NIST/USA.
3. The test was performed in 966 Chamber No. H.
4. The FCC Site Registration No. is 797305.
5. The CANADA Site Registration No. is IC 7450H-3.
6. Tested Date: Nov. 19, 2013

FOR ABOVE 1GHz TEST:

DESCRIPTION & MANUFACTURER	MODEL NO.	SERIAL NO.	CALIBRATED DATE	CALIBRATED UNTIL
*OML Harmonic Mixer (33~55GHz)	M22HWD	110215-1	Mar. 28, 2013	Mar. 28, 2015
*OML Horn Antenna (33~55GHz)	M22RH	110215-1	Mar. 28, 2013	Mar. 28, 2015
*Diplexer	DPL26	110215-1	Feb. 27, 2013	Feb. 26, 2015

Note:

1. The calibration interval of the above test instruments is 12 months and the calibrations are traceable to NML/ROC and NIST/USA.
2. The horn antenna, preamplifier (model: 8449B) are used only for the measurement of emission frequency above 1GHz if tested.
3. The test was performed in 966 Chamber No. G.
4. The FCC Site Registration No. is 966073.
5. The VCCI Site Registration No. is G-137.
6. The CANADA Site Registration No. is IC 7450H-2.
7. Tested Date: Nov. 19, 2013

4.2.3 TEST PROCEDURES

PROCEDURE FOR BELOW 18 GHz

- a. The EUT was placed on the top of a rotating table 0.8 meters above the ground at a 3 meters chamber room. The table was rotated 360 degrees to determine the position of the highest radiation.
- b. The EUT was set 3 meters away from the interference-receiving antenna, which was mounted on the top of a variable-height antenna tower.
- c. The height of antenna is varied from one meter to four meters above the ground to determine the maximum value of the field strength. Both horizontal and vertical polarizations of the antenna are set to make the measurement.
- d. For each suspected emission, the EUT was arranged to its worst case and then the antenna was tuned to heights from 1 meter to 4 meters and the rotatable table was turned from 0 degrees to 360 degrees to find the maximum reading.
- e. The spectrum analyzer system was set to quasi-peak detect function and specified bandwidth with maximum hold mode when the test frequency is below 1 GHz.
- f. The spectrum analyzer system was set to peak detect function and specified bandwidth with maximum hold mode when the test frequency is above 1 GHz.

PROCEDURE FOR ABOVE 18 GHz

External harmonic mixers are utilized.

- a. The EUT was placed on the top of a rotating table 0.8 meters above the ground at a 3 meters chamber room. The table was rotated 360 degrees to determine the position of the highest radiation.
- b. The distance at which limits are typically specified is 3 meter; however, closer measurement distances may be utilized.
- c. Begin handheld measurements with the test antenna (horn) at a distance of 1 meter from the EUT, in a horizontally polarized position. Slowly adjust its position, entirely covering the plane 1 meter from the EUT.
- d. Repeat (b) with the horn in a vertically polarized position.
- e. If the emission cannot be detected at 1 meter, reduce the RBW in order to increase system sensitivity. Note the value. If the emission still cannot be detected, move the horn closer to the EUT, noting the distance at which a measurement is made.
- f. Note the maximum level indicated on the Spectrum Analyzer.
- g. Based on the distance at which the measurement was made and the calculated distance to the edge of the far field, determine the appropriate distance attenuation factor. Apply this factor to the calculated field strength in order to determine the equivalent field strength at the distance at which the regulatory limit is specified. Compare to the appropriate limits
- h. Repeat (a) - (f) for every emission that must be measured, up through the required frequency range of investigation

NOTE:

1. The resolution bandwidth and video bandwidth of test receiver/spectrum analyzer is 120kHz for Quasi-peak detection (QP) at frequency below 1GHz.
2. The resolution bandwidth is 1MHz and video bandwidth of test receiver/spectrum analyzer is 3MHz for Peak detection at frequency above 1GHz.
3. Shorter measurement distances may be used to improve the measurement system's noise floor. As 15.245 description is based on the measurement in distance of 3 meters, the data obtained at 1-meter distance was compared to the calculate limit for 1-m distance:

Limit at 1-meter distance (dBuV)

= Limit at 3 meter distance (dBuV) - $20\log(1/3)$ (dB)

= Limit at 3 meter distance (dBuV) + 9.5(dB).

4.2.4 DEVIATION FROM TEST STANDARD

No deviation

4.2.5 TEST SETUP

<Frequency Range below 1GHz>

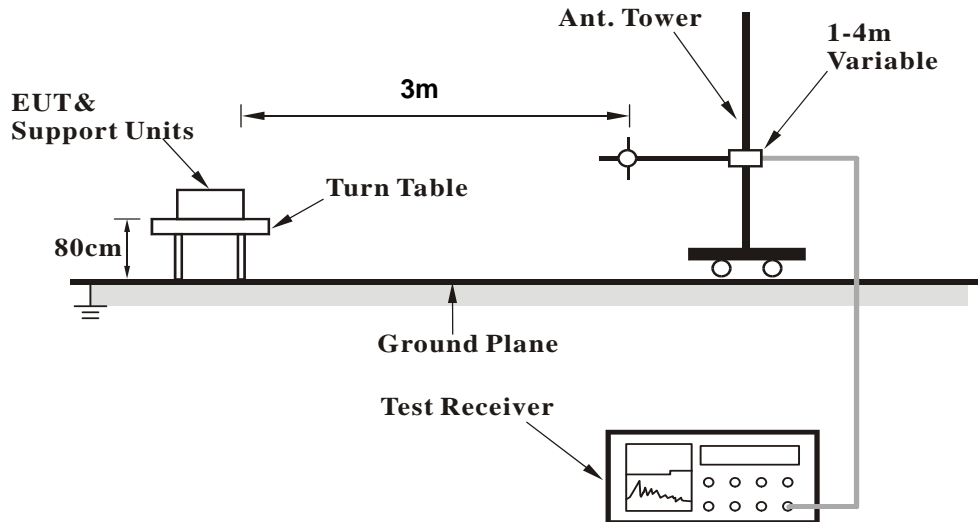

<Frequency Range above 1GHz>

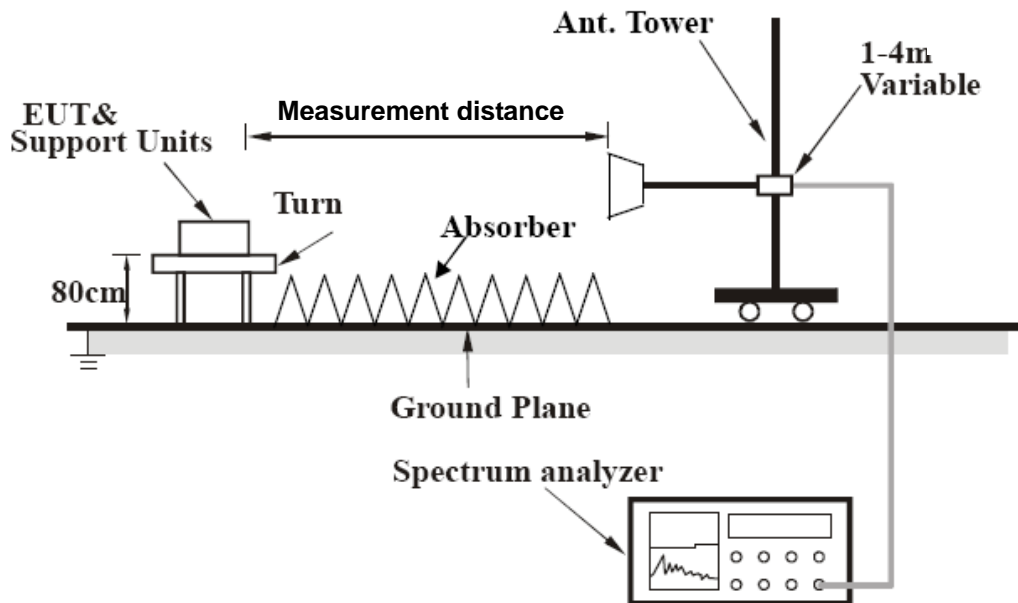

For the actual test configuration, please refer to the related item – Photographs of the Test Configuration.

4.2.6 EUT OPERATING CONDITIONS

Same as 4.1.6

4.2.7 TEST RESULTS (MODE 1)

BELOW 1GHz

CHANNEL	TX Channel 1	DETECTOR FUNCTION	Quasi-Peak (QP)
FREQUENCY RANGE	Below 1GHz		

ANTENNA POLARITY & TEST DISTANCE: HORIZONTAL AT 3 M								
NO.	FREQ. (MHz)	EMISSION LEVEL (dBuV/m)	LIMIT (dBuV/m)	MARGIN (dB)	ANTENNA HEIGHT (m)	TABLE ANGLE (Degree)	RAW VALUE (dBuV)	CORRECTION FACTOR (dB/m)
1	42.17	27.7 QP	40.0	-12.3	1.00 H	296	41.14	-13.42
2	83.45	27.0 QP	40.0	-13.0	2.00 H	107	45.18	-18.22
3	131.85	31.4 QP	43.5	-12.1	2.00 H	114	45.35	-13.99
4	199.07	25.9 QP	43.5	-17.6	1.25 H	88	41.76	-15.82
5	649.44	32.4 QP	46.0	-13.6	1.00 H	360	36.18	-3.75
6	940.59	30.1 QP	46.0	-15.9	1.75 H	98	28.89	1.25

ANTENNA POLARITY & TEST DISTANCE: VERTICAL AT 3 M								
NO.	FREQ. (MHz)	EMISSION LEVEL (dBuV/m)	LIMIT (dBuV/m)	MARGIN (dB)	ANTENNA HEIGHT (m)	TABLE ANGLE (Degree)	RAW VALUE (dBuV)	CORRECTION FACTOR (dB/m)
1	42.13	36.1 QP	40.0	-3.9	1.00 V	227	49.50	-13.43
2	61.51	29.3 QP	40.0	-10.7	1.00 V	157	42.64	-13.34
3	75.82	30.8 QP	40.0	-9.2	1.00 V	169	47.59	-16.79
4	110.95	32.7 QP	43.5	-10.8	1.00 V	83	48.05	-15.35
5	609.87	30.2 QP	46.0	-15.8	1.00 V	100	34.69	-4.46
6	977.93	35.2 QP	54.0	-18.8	1.00 V	283	33.16	2.06

REMARKS:

1. Emission Level(dBuV/m) = Raw Value(dBuV) + Correction Factor(dB/m)
2. Correction Factor(dB/m) = Antenna Factor(dB/m) + Cable Factor(dB) – Pre-Amplifier Factor(dB)
3. The other emission levels were very low against the limit.
4. Margin value = Emission Level – Limit value



A D T

1~ 53 GHz

CHANNEL	TX Channel 1	DETECTOR FUNCTION	Peak (PK)
FREQUENCY RANGE	1GHz ~ 53GHz		

ANTENNA POLARITY & TEST DISTANCE: HORIZONTAL

NO.	FREQ. (MHz)	EMISSION LEVEL (dBuV/m)	LIMIT (dBuV/m)	MARGIN (dB)	ANTENNA HEIGHT (m)	TABLE ANGLE (Degree)	RAW VALUE (dBuV)	CORRECTION FACTOR (dB/m)
1	10500.00	71.6 PK	74.0	-2.4	1.18 H	219	57.01	14.59
2	10500.00	48.9 AV	54.0	-5.1	1.18 H	219	34.31	14.59
3	*10525.00	111.6 PK	148.0	-36.4	1.18 H	219	96.96	14.64
4	*10525.00	88.9 AV	128.0	-39.1	1.18 H	219	74.26	14.64
5	10550.00	61.6 PK	74.0	-12.4	1.18 H	219	46.91	14.69
6	10550.00	38.9 AV	54.0	-15.1	1.18 H	219	24.21	14.69
7	21050.00	66.9 PK	117.5	-50.6	1.00 H	0	62.79	4.11
8	21050.00	44.2 AV	97.5	-53.3	1.00 H	0	40.09	4.11
9	31575.00	53.7 PK	117.5	-63.8	1.00 H	0	41.21	12.49
10	31575.00	31.0 AV	97.5	-66.5	1.00 H	0	18.51	12.49

ANTENNA POLARITY & TEST DISTANCE: VERTICAL

NO.	FREQ. (MHz)	EMISSION LEVEL (dBuV/m)	LIMIT (dBuV/m)	MARGIN (dB)	ANTENNA HEIGHT (m)	TABLE ANGLE (Degree)	RAW VALUE (dBuV)	CORRECTION FACTOR (dB/m)
1	10500.00	59.2 PK	74.0	-14.8	1.14 V	65	44.61	14.59
2	10500.00	36.5 AV	54.0	-17.5	1.14 V	65	21.91	14.59
3	*10525.00	97.2 PK	148.0	-50.8	1.14 V	65	82.56	14.64
4	*10525.00	74.5 AV	128.0	-53.5	1.14 V	65	59.86	14.64
5	10550.00	56.8 PK	74.0	-17.2	1.14 V	65	42.11	14.69
6	10550.00	34.1 AV	54.0	-19.9	1.14 V	65	19.41	14.69
7	21050.00	62.2 PK	117.5	-55.3	1.00 V	0	58.09	4.11
8	21050.00	39.5 AV	97.5	-58.0	1.00 V	0	35.39	4.11
9	31575.00	61.3 PK	117.5	-56.2	1.00 V	0	48.81	12.49
10	31575.00	38.6 AV	97.5	-58.9	1.00 V	0	26.11	12.49

There is no spurious emission were detected between 40 to 53 GHz

REMARKS:

- Emission Level(dBuV/m) = Raw Value(dBuV) + Correction Factor(dB/m)
- Correction Factor(dB/m) = Antenna Factor(dB/m) + Cable Factor(dB) – Pre-Amplifier Factor(dB)
- The other emission levels were very low against the limit.
- Margin value = Emission Level – Limit value
- " * ": Fundamental frequency.
- The average value of fundamental frequency is: Average = Peak value + 20 log(Duty cycle)
Where the duty factor is calculated from following formula:
 $20 \log (\text{Duty cycle}) = 20 \log (0.024 \text{ ms} / 0.327 \text{ ms}) = -22.7 \text{ dB}$
Please see page 30 for plotted duty.
- Spurious emission above 18GHz
 - The measurement distance of above 18 GHz is 1meter.
 - The limit of 1meter distance = 3 meter distance limit + 9.5 dB.



A D T

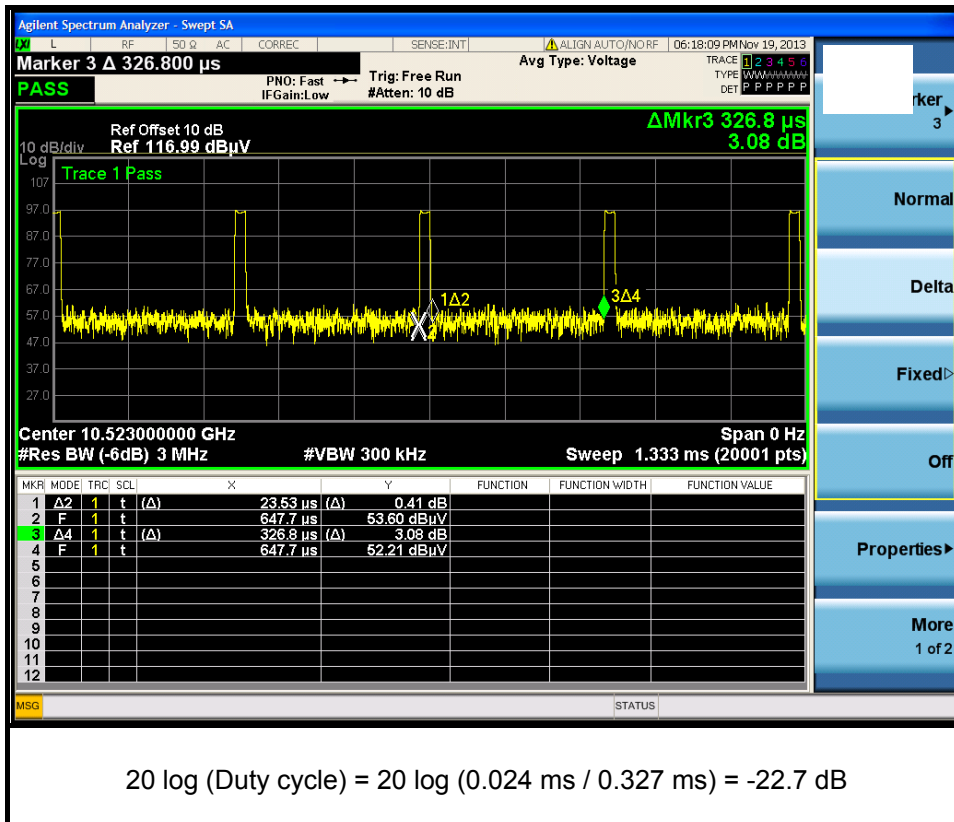

4.2.8 TEST RESULTS (MODE 2)

BELOW 1GHz

CHANNEL	TX Channel 1	DETECTOR FUNCTION	Quasi-Peak (QP)
FREQUENCY RANGE	Below 1GHz		

ANTENNA POLARITY & TEST DISTANCE: HORIZONTAL AT 3 M								
NO.	FREQ. (MHz)	EMISSION LEVEL (dBuV/m)	LIMIT (dBuV/m)	MARGIN (dB)	ANTENNA HEIGHT (m)	TABLE ANGLE (Degree)	RAW VALUE (dBuV)	CORRECTION FACTOR (dB/m)
1	42.08	25.5 QP	40.0	-14.6	1.75 H	334	38.90	-13.45
2	83.01	26.6 QP	40.0	-13.4	2.00 H	112	44.67	-18.06
3	130.59	27.9 QP	43.5	-15.6	2.00 H	117	41.98	-14.10
4	204.50	30.1 QP	43.5	-13.4	1.25 H	349	45.93	-15.85
5	314.99	34.5 QP	46.0	-11.5	1.50 H	91	45.50	-10.97
6	940.64	30.2 QP	46.0	-15.8	2.00 H	208	28.99	1.25
ANTENNA POLARITY & TEST DISTANCE: VERTICAL AT 3 M								
NO.	FREQ. (MHz)	EMISSION LEVEL (dBuV/m)	LIMIT (dBuV/m)	MARGIN (dB)	ANTENNA HEIGHT (m)	TABLE ANGLE (Degree)	RAW VALUE (dBuV)	CORRECTION FACTOR (dB/m)
1	41.35	31.3 QP	40.0	-8.7	1.00 V	317	44.89	-13.56
2	83.16	29.1 QP	40.0	-10.9	1.50 V	360	47.22	-18.11
3	131.70	28.3 QP	43.5	-15.2	1.00 V	0	42.31	-14.01
4	211.05	28.3 QP	43.5	-15.2	1.50 V	44	44.04	-15.74
5	824.96	32.8 QP	46.0	-13.2	1.00 V	238	33.33	-0.53
6	940.64	30.7 QP	46.0	-15.3	1.75 V	299	29.49	1.25

REMARKS:

1. Emission Level(dBuV/m) = Raw Value(dBuV) + Correction Factor(dB/m)
2. Correction Factor(dB/m) = Antenna Factor(dB/m) + Cable Factor(dB) – Pre-Amplifier Factor(dB)
3. The other emission levels were very low against the limit.
4. Margin value = Emission Level – Limit value

4.3 BANDEDGE MEASUREMENT

4.3.1 LIMITS OF BANDEDGE

According to 15.215(c), the requirement is to ensure the 20dB bandwidth of the emission, or whatever bandwidth may otherwise be specified, is contained within the frequency band designated in the rule section under which the equipment is operated.

4.3.2 TEST INSTRUMENTS

DESCRIPTION & MANUFACTURER	MODEL NO.	SERIAL NO.	CALIBRATED DATE	CALIBRATED UNTIL
SPECTRUM ANALYZER R&S	FSP40	100036	Jan. 21, 2013	Jan. 20, 2014

Note:

1. The calibration interval of the above test instruments is 12 months and the calibrations are traceable to NML/ROC and NIST/USA.
2. Tested date : Nov. 20, 2013

4.3.3 TEST PROCEDURE

The transmitter output was connected to the spectrum analyzer via a low lose cable. Set both RBW and VBW of spectrum analyzer to 100 kHz and 300 kHz with suitable frequency span from band edge. The band edges was measured and recorded.

4.3.4 DEVIATION FROM TEST STANDARD

No deviation

4.3.5 EUT OPERATING CONDITION

Set the EUT under transmission / receiver condition continuously at specific channel frequency.



A D T

4.3.6 TEST RESULTS

FOR 20dB BANDWIDTH

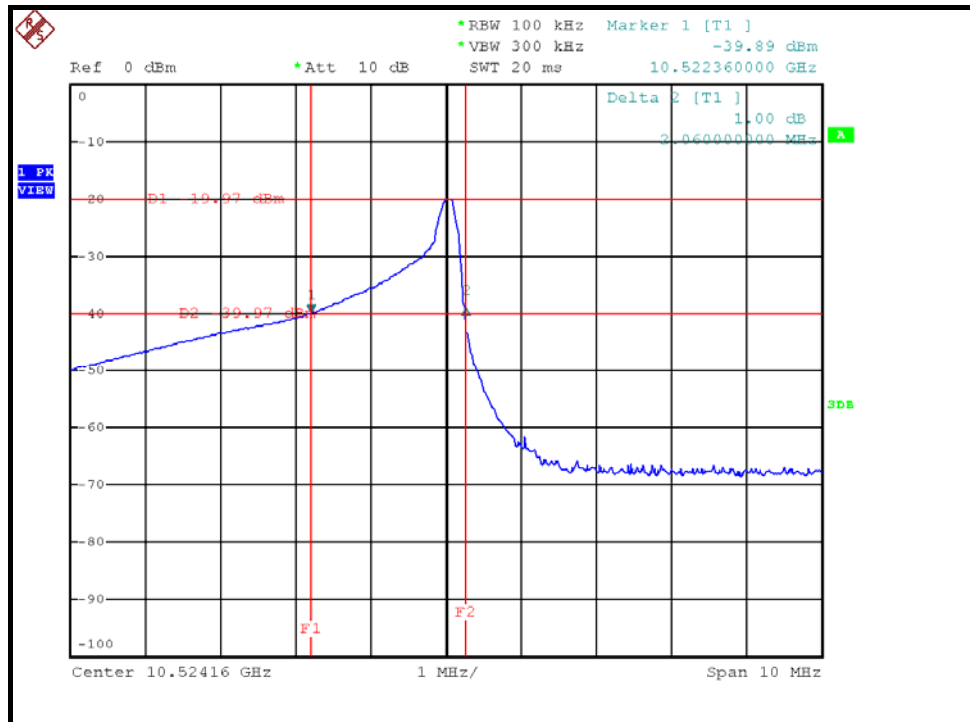



A D T

FOR BANDEGE

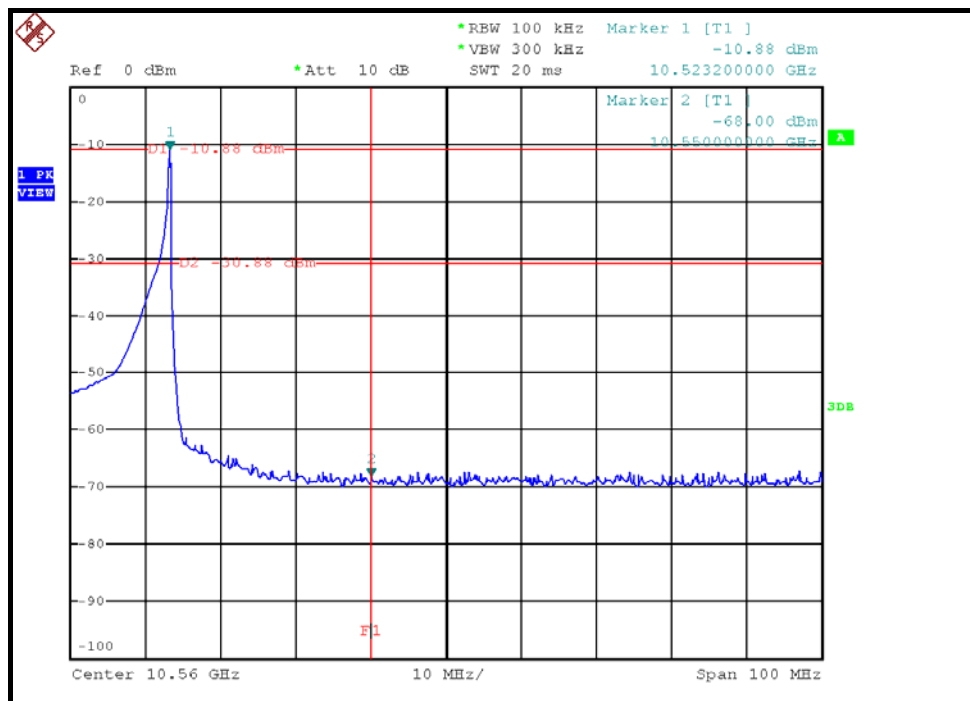
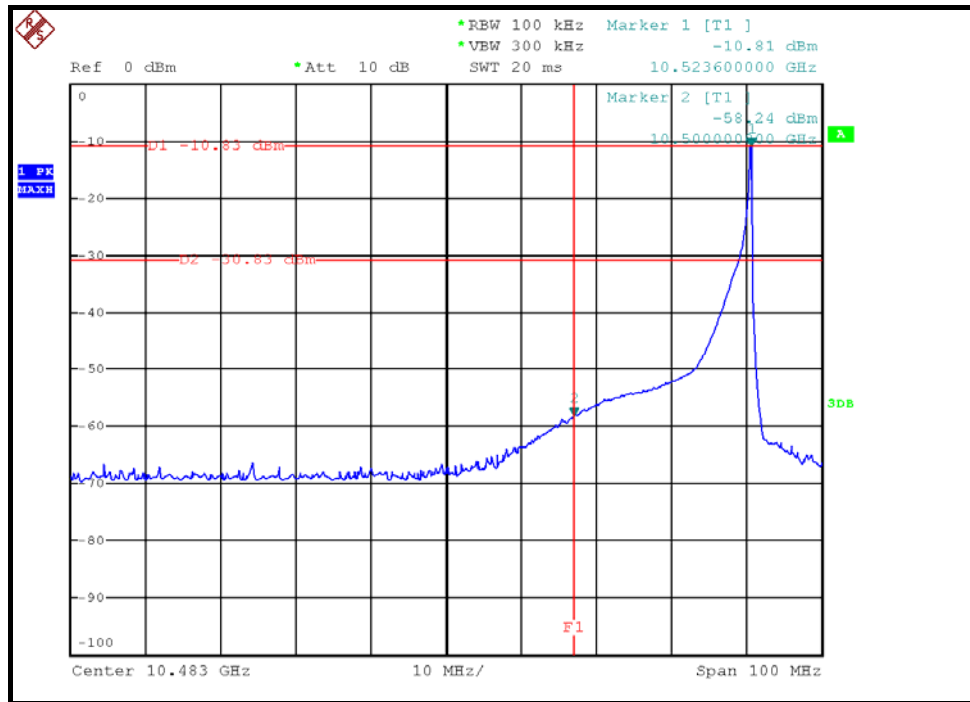



5 PHOTOGRAPHS OF THE TEST CONFIGURATION

Please refer to the attached file (Test Setup Photo).



6 INFORMATION ON THE TESTING LABORATORIES

We, Bureau Veritas Consumer Products Services (H.K.) Ltd., Taoyuan Branch, were founded in 1988 to provide our best service in EMC, Radio, Telecom and Safety consultation. Our laboratories are accredited and approved according to ISO/IEC 17025.

If you have any comments, please feel free to contact us at the following:

Linko EMC/RF Lab:

Tel: 886-2-26052180

Fax: 886-2-26052943

Hsin Chu EMC/RF Lab:

Tel: 886-3-5935343

Fax: 886-3-5935342

Hwa Ya EMC/RF/Safety/Telecom Lab:

Tel: 886-3-3183232

Fax: 886-3-3270892

Email: service.adt@tw.bureauveritas.com

Web Site: www.bureauveritas-adt.com

The address and road map of all our labs can be found in our web site also.



7 APPENDIX A - MODIFICATIONS RECORDERS FOR ENGINEERING CHANGES TO THE EUT BY THE LAB

No modifications were made to the EUT by the lab during the test.

--- END ---