

Secure ◀▶ Simple ▶◀ State of the Art

RF-SWDS Wireless Door/Window Sensor

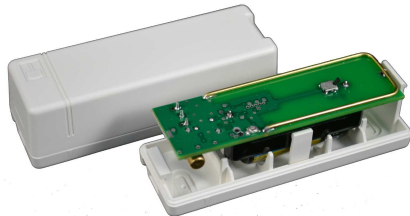

Part #: RF-SDWS-MAG (Wireless Door/Window Sensor)

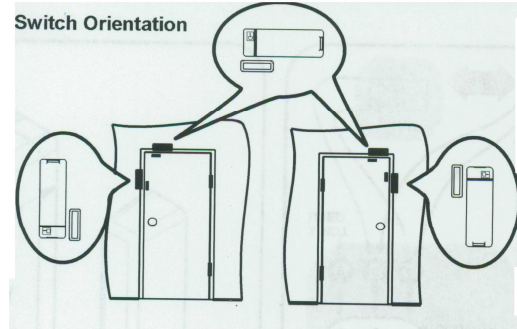

Product Summary

The Wireless Door/Window Sensor is compatible with all Interlogix wireless control panels. The device is surface mounted and equipped with an internal contact and the capability of using an external contact. A cover tamper doubles as an enrollment switch.

Installation:

The sensor is designed to mount on the door or window frame and the magnet on the door or window (moving part).

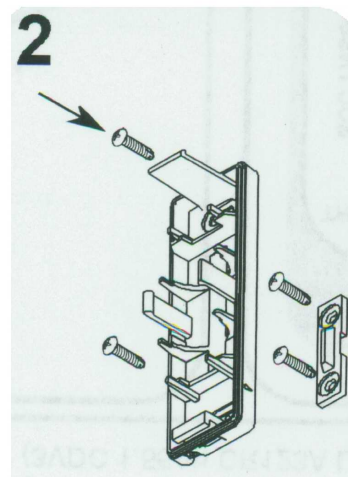
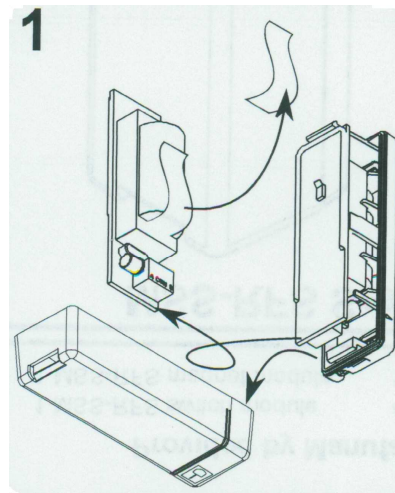

Secure ◀▶ Simple ◀▶ State of the Art

RF-SWDS Wireless Door/Window Sensor

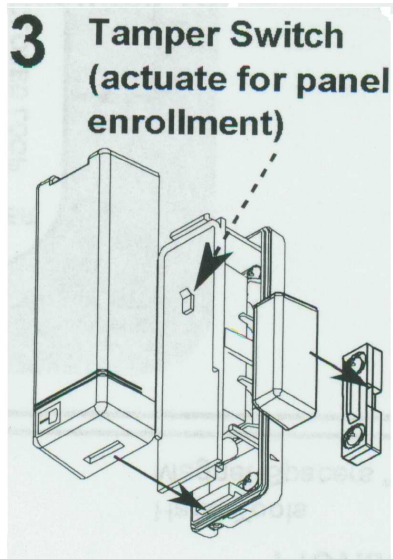

Specifications:

Battery: 3VDC, 1.55Ah,
CR123A Lithium Battery
Typical Battery Life: Up to 14+ Years

External Input Sampling
Current: 20 μ A

Switch Type: Reed

Operating Gap: 0.63 in (1.60 cm)

Magnet Type: Neodymium
Iron Boron (Rare Earth)

Supervisory Interval:
64 minutes

Wire Run to External Input:
100 feet (30.5 m)

Operating Temperature:
14°F (-10°C) to 140°F (60°C)

Enclosure: ABS POLYLAC® PA-717C
(UL94 HB flame-rating)

Weight: 1.6 oz. (51g)

Switch Dimensions: 3.2 in
(81.3 mm) L x 1.04 in (26.4 mm)
W x .96 in (24.4 mm) H

Magnet Dimensions: 1.3 in
(33 mm) L x 0.5 in (1.27
mm) H x 0.43 in (10.9 mm) W
Color: White or Brown

Wiring:

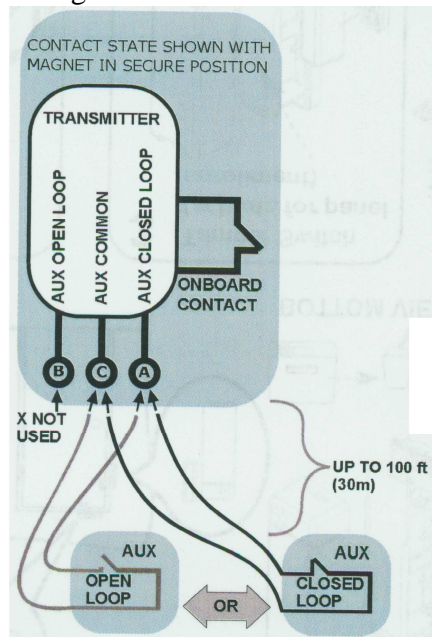

Programming:

See control panel installation instructions for programming references.

RF-SWDS Wireless Door/Window Sensor

FCC:**FCC label statement:**

"This device complies with part 15 of the FCC Rules. Operation is subject to the following two conditions: (1) This device may not cause harmful interference, and (2) this device must accept any interference received, including interference that may cause undesired operation."

"Note: This equipment has been tested and found to comply with the limits for a Class B digital device, pursuant to part 15 of the FCC Rules. These limits are designed to provide reasonable protection against harmful interference in a residential installation. This equipment generates, uses and can radiate radio frequency energy and, if not installed and used in accordance with the instructions, may cause harmful interference to radio communications. However, there is no guarantee that interference will not occur in a particular installation. If this equipment does cause harmful interference to radio or television reception, which can be determined by turning the equipment off and on, the user is encouraged to try to correct the interference by one or more of the following measures:

- Reorient or relocate the receiving antenna.*
- Increase the separation between the equipment and receiver.*
- Connect the equipment into an outlet on a circuit different from that to which the receiver is connected.*
- Consult the dealer or an experienced radio/TV technician for help."*

"Changes or modifications not expressly approved by the party responsible for compliance could void the user's authority to operate the equipment"

"RF Exposure Guidance: *This equipment complies with FCC radiation exposure limits set forth for an uncontrolled environment. This equipment should be installed and operated with a minimum distance of 1.5cm between the radiator and persons. This transmitter must not be co-located or operating in conjunction with any other antenna or transmitter, except in accordance with FCC multi-transmitter product procedures."*

I.C.:**I.C. label Statement:****IC: 11817A-RFSDWS**

"This device complies with Industry Canada licence-exempt RSS standard(s). Operation is subject to the following two conditions: (1) this device may not cause interference, and (2) this device must accept any interference, including interference that may cause undesired operation of the device.

Le présent appareil est conforme aux CNR d'Industrie Canada applicables aux appareils radio exempts de licence. L'exploitation est autorisée aux deux conditions suivantes : (1) l'appareil ne doit pas produire de brouillage, et (2) l'utilisateur de l'appareil doit accepter tout brouillage radioélectrique subi, même si le brouillage est susceptible d'en compromettre le fonctionnement. »

Under Industry Canada regulations, this radio transmitter may only operate using an antenna of a type and maximum (or lesser) gain approved for the transmitter by Industry Canada. To reduce potential radio interference to other users, the antenna type and its gain should be so chosen that the equivalent isotropically radiated power (e.i.r.p.) is not more than that necessary for successful communication.

Conformément à la réglementation d'Industrie Canada, le présent émetteur radio peut fonctionner avec une antenne d'un type et d'un gain maximal (ou inférieur) approuvé pour l'émetteur par Industrie Canada. Dans le but de réduire les risques de brouillage radioélectrique à l'intention des autres utilisateurs, il faut choisir le type d'antenne et son gain de sorte que la puissance isotrope rayonnée équivalente (p.i.r.e.) ne dépasse pas l'intensité nécessaire à l'établissement d'une communication satisfaisante.