

CMM-9209-V4.0

Long Range 2.4GHz Transceiver Module



This module is limited to OEM installation ONLY

Description

The CMM-9209 module is a miniaturised long range 2.4GHz transceiver module based on EM Micro-electronic's RF transceiver EM9209. The module is highly optimized for long-range wireless application requiring ultra low power consumption and short time-to-market. It offers a plug and play solution for any EM9209 application without any additional hardware nor RF layout. Built in with a PCB strip antenna, this small sized, low cost module provides an ideal solution to wireless 2.4GHz license-free application worldwide.

The EM9209 is a low-voltage 2.4GHz transceiver IC with built-in link-layer logic permitting proprietary wireless links in the license-free 2.400 ... 2.4835 GHz ISM band. This solution is ideal for battery operated wireless applications such as wireless sensors and control, toys, human interface devices, security and metering networks.

1.1 Features

- Fully integrated 2.4 GHz transceiver (Chip on Board)
- Operating voltage 1.9V ~ 3.6V
- Mini-sized (18.5mm x 14mm)
- Programmable RF output level (-10 dBm to +10 dBm) via software control
- Low current consumption
(1uA at power down mode, 8.2 mA RX (high sensitivity mode), 11.2 mA in TX mode (-1 dBm))
- No Tuning necessary
- Programmable data rate (3kbps, 6 kbps, 12 kbps)
- Reaches max 500m in open space line of sight
- FSK modulation
- SPI interface to host controller

1.2 Module Dimension & Pin Assignments

Pin Number	Pin Name	Pin Description
1	GND	Ground Connection
2	EN_REG	Master Chip Enable Signal
3	IRQ	Interrupt Output for external host Controller
4	MISO	SPI Data Output
5	MOSI	SPI Data Input
6	SS	SPI Slave Select(Active High)
7	SCK	SPI Clock Input
8	VDD	Positive Power Supply

CMM-9209-V4.0 Long Range 2.4GHz Transceiver Module

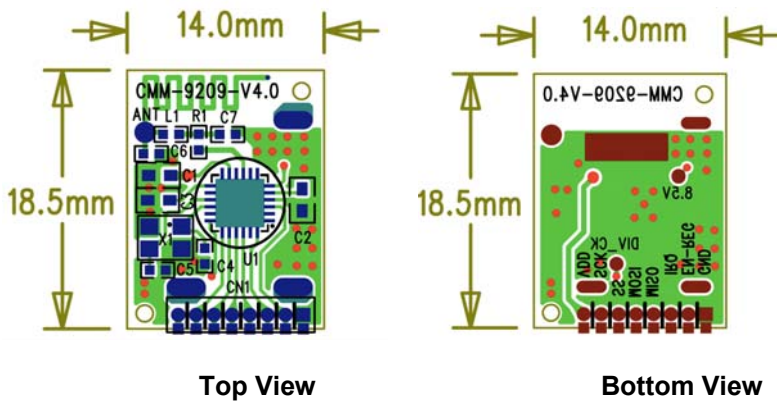

*** Connection pin pitch : 1.27mm

CMM-9209-V4.0/4.0P Module Thickness (excluding pin header connectors, excluding shielding) = 2.1mm max.
 CMM-9209-V4.0F/4.0X Module Thickness (excluding pin header connectors, including shielding) = 3.3mm max.

1.3 Recommended PCB layout and foot print

Footprint:

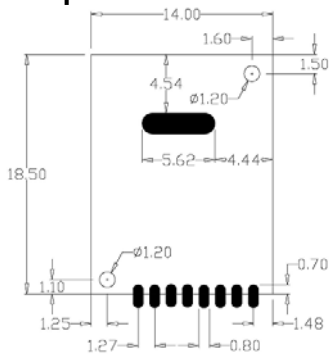

Layout Under Module:

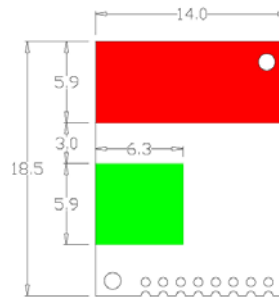

Layout Around module:

- : Clearance area (no routing, components or copper plane)
- : Ground plane recommended

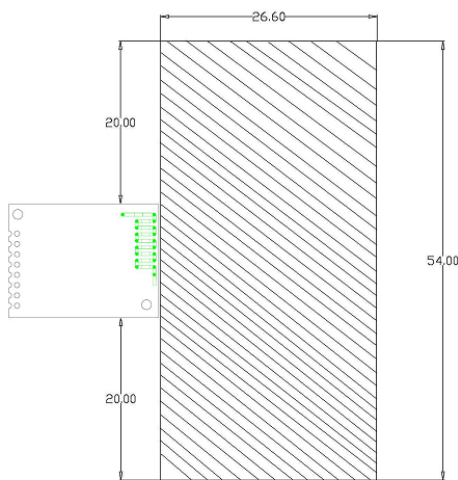

Do not place copper or any metal in the area marked with cross line

UNIT: mm

CMM-9209-V4.0 Long Range 2.4GHz Transceiver Module



1.4 Pinning Dimensions and definitions

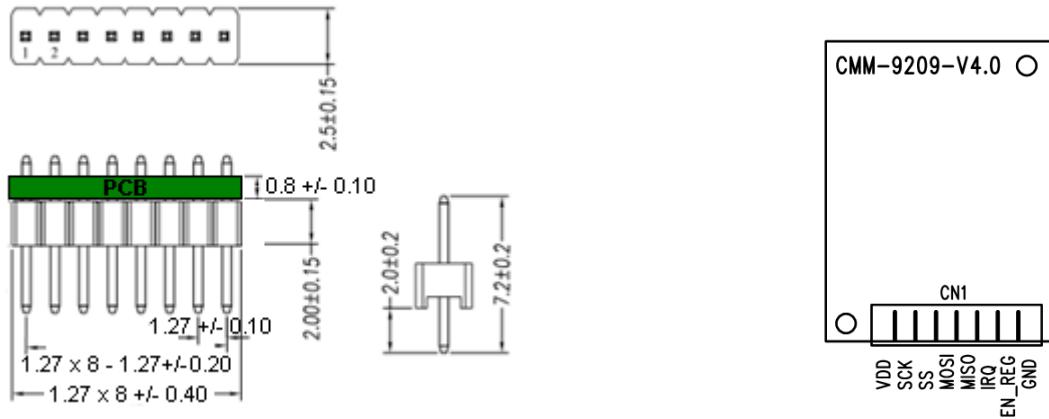

Pin Connection Dimension (applicable only for CMM-9209-V4.0P/4.0X)

Pin Definition

1.5 Module Reference Circuit diagram

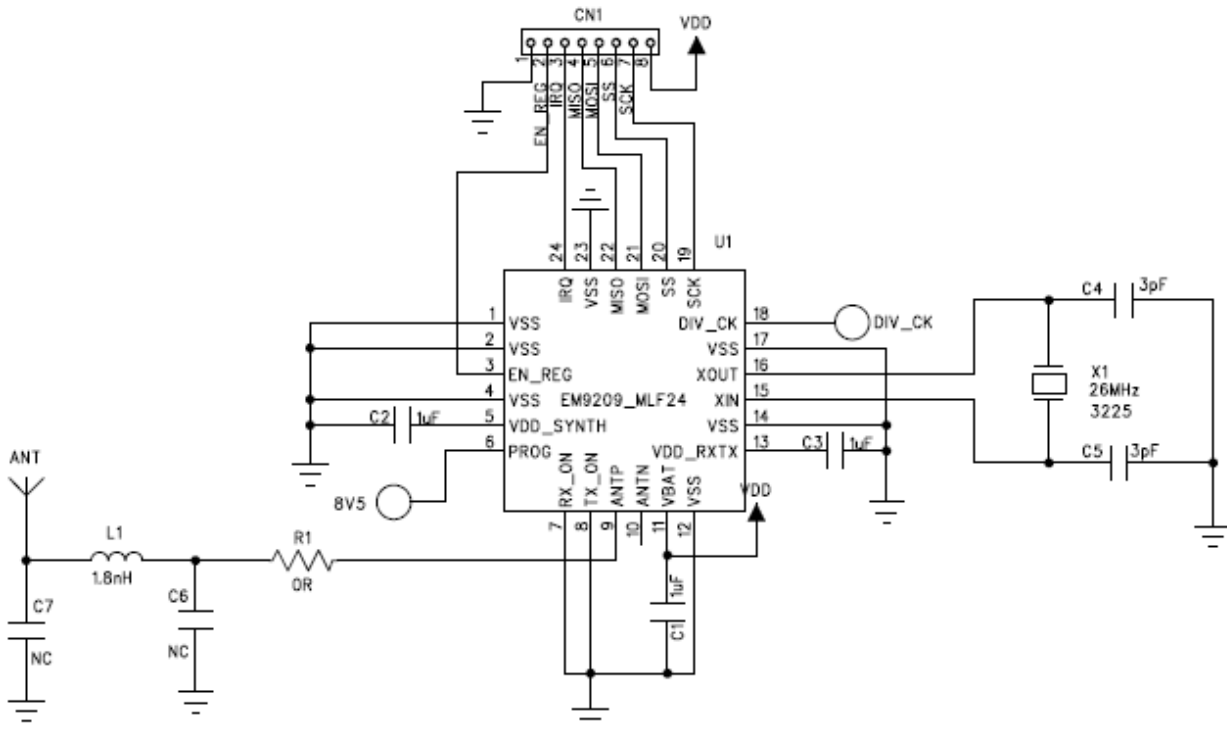

CMM-9209-V4.0 Long Range 2.4GHz Transceiver Module



1.6 Module Electrical Specifications

Specification	CMM-9209-V4.0/4.0P/4.0F/4.0X				
Voltage Range	1.9V to 3.6V				
Frequency Range	2.408 to 2.474 GHz				
Modulation	FSK				
On-air data rate configurable	3 kbps, 6 kbps, 12 kbps				
Maximum Allowable Data bytes in payload per transmission	Data rate (Kbps)	Preamble (byte)	Address (byte)	header (byte)	Payload (byte)
	3	2	3	1	8
	6	2	3	1	31
	12	2	3	1	31
Current Consumption (V _{cc} = 2.5V)					
- RX mode	8.2mA (High sensitivity mode)				
- TX mode	varies according to output power (see below)				
- Standby mode	140 uA (typ.)				
- Power-down mode	1uA				
Programmable output power vs TX current consumption	Output Power [dBm]	PA Power efficiency [%]	DC total Current Consumption [mA]		
	+10	27.3	36.3		
	+9.3	29.7	29.5		
	+6.6	24.2	20.7		
	+2.7	15.8	14.4		
	-1.1	9.4	11.2		
	-3.1	7	10.2		
	-10.4	1.9	8.1		
Module Sensitivity					
<p>The graph shows Sensitivity [dBm] on the y-axis (ranging from -115 to -96) and Air data rate R_Bit_Clk[8:0] and Ch-Rate[2:0] on the x-axis. Vertical bars represent sensitivity for different data rates: 2kbps, 3kbps (001), 4kbps, 6kbps (010), 8kbps, 12kbps (011), and 16kbps. The 3kbps, 6kbps, and 12kbps modes are labeled as 'High Sensitivity modes' and show significantly lower sensitivity (higher dBm values) compared to other modes.</p>					
RF setup time (Standby <-> TX/RX)	Max 200 us				

CMM-9209-V4.0 Long Range 2.4GHz Transceiver Module



2. Temperature Profile for Lead-free Reflow Soldering (only applicable for CMM-9209-V4.0F)

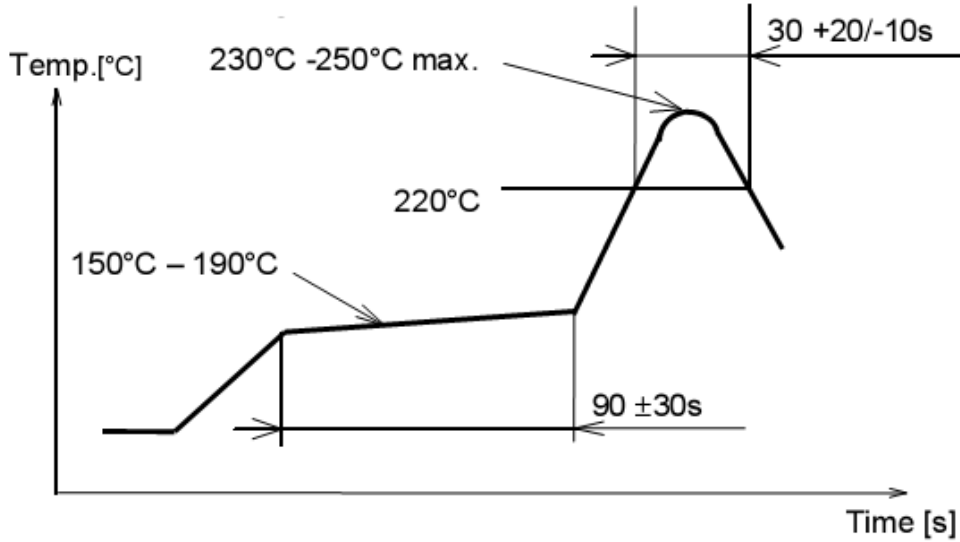

3. Ordering information

Module Part Number	Module Assembly process type	Pin Headers on Module	Shield on Module	Qualification Cert.	Packaging
CMM-9209-V4.0	Hand soldering	X	X	FCC, CE pre-scan passed	In Trays
CMM-9209-V4.0F	SMT + reflow	X	✓	FCC, CE Pending	Tape & Reel
CMM-9209-V4.0P	Plug-in	✓	X	FCC, CE pre-scan passed	In Trays
CMM-9209-V4.0X	Plug-in	✓	✓	FCC, CE Pending	In Trays

CMM-9209-V4.0

Long Range 2.4GHz Transceiver Module



4. Packaging Information

CMM-9209-V4.0F - Tape and Reel

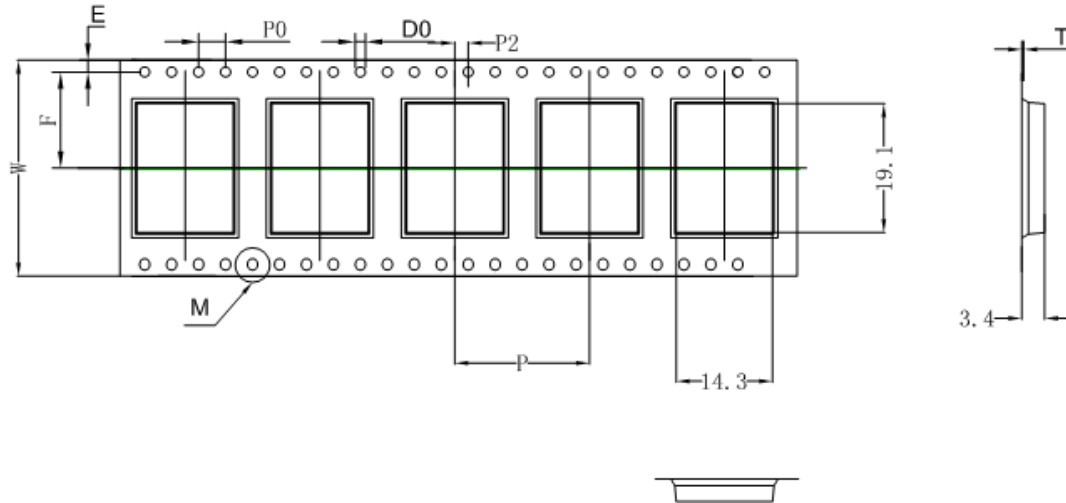

Item	D ₀	D ₁	P ₀	P ₂	E	W	A ₀	A ₁
Dimension	1.50 +0.10-0.00	0.00 +0.00-0.00	4.00 +0.10-0.10	2.00 +0.10-0.10	1.75 +0.10-0.10	32.0 +0.30-0.30	14.3 +0.10-0.10	0.00 +0.10-0.10

Item	B ₀	B ₁	K ₀	K ₁	P	F	T
Dimension	19.1 +0.10-0.10	0.00 +0.00-0.00	3.40 +0.10-0.10	0.00 +0.10-0.10	20.0 +0.10-0.10	14.2 +0.10-0.10	0.30 +0.05-0.05

5. FCC Statement

NOTICE: This device complies with Part 15 of the FCC Rules. Operation is subject to the following two conditions:

- This device may not cause harmful interference, and
- This device must accept any interference received, including interference that may cause undesired operation.

The Grantee is not responsible for any changes or modifications not expressly approved by the party responsible for compliance. Such modifications could void the user's authority to operate the equipment.

This equipment has been tested and found to comply with the limits for a Class B digital device, pursuant to Part 15 of the FCC Rules. These limits are designed to provide reasonable protection against harmful interference in a residential installation. This equipment generates, uses and can radiate radio frequency energy and if not installed and used in accordance with the instructions, may cause harmful interference to radio communications. However, there is no guarantee that interference will not occur in a particular installation. If this equipment does cause harmful interference to radio or television reception, which can be determined by turning the equipment off and on, the user is encouraged to try to correct the interference by one or more of the following measures:

CMM-9209-V4.0

Long Range 2.4GHz Transceiver Module



- Reorient or relocate the receiving antenna.
- Increase the separation between the equipment and receiver
- Connect the equipment into an outlet on a circuit different from that to which the receiver is connected.
- Consult the dealer or an experienced radio/TV technician for help

Radio frequency radiation exposure information:

This equipment complies with FCC radiation exposure limits set forth for an uncontrolled environment. Please see the RF Exposure information. This transmitter must not be co-located or operating in conjunction with any other antenna or transmitter.

This device should be installed and operated with a minimum distance of 20cm between the antenna and all persons.

Label requirements:

Contains: FCC ID: 2ABBXCM9209V402015

FCC RF Exposure Requirement:

- At least 20cm separation distance between the antenna and the user's body must be maintained at all times. And must not transmit simultaneously with any other antenna or transmitter, except in accordance with FCC multi transmitter product procedures.
- To comply with FCC regulations limiting both maximum RF output power and human exposure to RF radiation, the maximum antenna gain including cable loss in a mobile-only exposure condition must not exceed 0dBi in the 2.4GHz band.
- A user manual with the end product must clearly indicate the operating requirements and conditions that must be observed to ensure compliance with current FCC RF exposure guidelines.

Note: If this module is intended for use in a portable device, you are responsible for separate approval to satisfy the SAR requirements of FCC Part 2.1093.

Please be noted that the following information and instructions should be placed in the end-user's operating manual.

The CMM-9209-V4.0 Module must be installed in the designated host as specified in this manual.

- Separate approval is required for all other operating configurations, including portable configurations with respect to 2.1093 and different antenna configurations.
- The CMM-9209-V4.0 Module and its antenna must not be co-located or operating in conjunction with any other transmitter or antenna within a host device. This equipment complies with FCC RF radiation exposure limits set forth for an uncontrolled environment.
- A label must be affixed to the outside of the end product into which the CMM-9209-V4.0 Module is incorporated, with a statement similar to the following: For CMM-9209-V4.0: This device contains FCC ID: 2ABBXCM9209V402015.
- The module shall be in non-detachable construction protection into the finished products, so that the end-user has to destroy the module while remove or install it.
- This module is to be installed only in mobile or fixed applications. According to FCC part 2.1091(b) definition of mobile and fixed devices is:

SPEC No.	Revision	State	C-MAX printed	Version	Page
CMM-9209-V4.0 2.4GHz Transceiver module	1.6	2015-02-25	2015-02-25	English	7 of 10

CMM-9209-V4.0

Long Range 2.4GHz Transceiver Module



Mobile Device:

A mobile device is defined as a transmitting device designed to be used in other than fixed locations and to generally be used in such a way that a separation distance of at least 20 centimeters is normally maintained between the transmitter's radiating structure(s) and the body of the user or nearby persons. In this context, the term "fixed location" means that the device is physically secured at one location and is not able to be easily moved to another location.

Portable Device:

For purposes of this section, a portable device is defined as a transmitting device designed to be used so that the radiating structure(s) of the device is/are within 20 centimeters of the body of the user.

- Separate approval is required for all other operating configurations, including portable configurations with respect to FCC Part 2.1093 and different antenna configurations.
- A certified modular has the option to use a permanently affixed label, or an electronic label. For a permanently affixed label, the module must be labeled with an FCC ID: 2ABBXCM9209V402015. The OEM manual must provide clear instructions explaining to the OEM the labeling requirements, options and OEM user manual instructions that are required.
- For a host using this FCC certified modular with a standard fixed label, if (1) the module's FCC ID is not visible when installed in the host, or (2) if the host is marketed so that end users do not have straightforward commonly used methods for access to remove the module so that the FCC ID of the module is visible; then an additional permanent label referring to the enclosed module: "Contains: FCC ID : 2ABBXCM9209V402015" must be used. The host OEM user manual must also contain clear instructions on how end users can find and/or access the module and the FCC ID.
- Host product is required to comply with all applicable FCC equipment authorizations regulations, requirements and equipment functions not associated with the transmitter module portion, compliance must be demonstrated to regulations for other transmitter components within the host product; to requirements for unintentional radiators (Part 15B). To ensure compliance with all non-transmitter functions the host manufacturer is responsible for ensuring compliance with the module(s) installed and fully operational. If a host was previously authorized as an unintentional radiator under the Declaration of Conformity procedure without a transmitter certified module and a module is added, the host manufacturer is responsible for ensuring that after the module is installed and operational the host continues to be compliant with the Part 15B unintentional radiator requirements. Since this may depend on the details of how the module is integrated with the host, the grantee (the party responsible for the module grant) shall provide guidance to the host manufacturer for compliance with the Part 15B requirements.

OEM RESPONSIBILITIES TO COMPLY WITH FCC REGULATIONS

The CMM-9209-V4.0 Module has been certified for integration into products only by OEM integrators under the following conditions: This device is granted for use in Mobile only configurations in which the antennas used for this transmitter must be installed to provide a separation distance of at least 20 centimeters from all persons and not be co-located with any other transmitters except in accordance with FCC and Industry Canada multi-transmitter product procedures.

As long as the two conditions above are met, further transmitter testing will not be required. However, the OEM integrator is still responsible for testing their end-product for any additional compliance requirements required with this module installed (for example, digital device emissions, PC peripheral requirements, etc.).

SPEC No.	Revision	State	C-MAX printed	Version	Page
CMM-9209-V4.0 2.4GHz Transceiver module	1.6	2015-02-25	2015-02-25	English	8 of 10

CMM-9209-V4.0

Long Range 2.4GHz Transceiver Module



IMPORTANT NOTE:

In the event that these conditions cannot be met (for certain configurations or co-location with another transmitter), then the FCC and Industry Canada authorizations are no longer considered valid and the FCC ID and IC Certification Number cannot be used on the final product. In these circumstances, the OEM integrator will be responsible for re-evaluating the end product (including the transmitter) and obtaining a separate FCC and Industry Canada authorization.

OEM LABELING REQUIREMENTS FOR END-PRODUCT

The CMM-9209-V4.0 module is labeled with its own FCC ID Certification Number. The FCC ID certification numbers are not visible when the module is installed inside another device, as such the end device into which the module is installed must display a label referring to the enclosed module. The final end product must be labeled in a visible area with the following: "Contains: FCC ID: 2ABBXCM9209V402015".

The OEM of the CMM-9209-V4.0 Module must only use the approved antenna(s) listed above, which have been certified with this module. The device carries FCC authorization and is marked with the FCC ID Number. Whilst any device into which this authorized module is installed will not normally be required to obtain FCC authorization, this does not preclude the possibility that some other form of authorization or testing may be required for the finished device.

OEM END PRODUCT USER MANUAL STATEMENTS

The OEM integrator should not provide information to the end user regarding how to install or remove this RF module or change RF related parameters in the user manual of the end product.

If this module is intended for use in a portable device, you are responsible for separate approval to satisfy the SAR requirements of FCC Part 2.1093.

The user manual for the end product must include the following information in a prominent location:

This device is granted for use in mobile only configurations in which the antennas used for this transmitter must be installed to provide a separation distance of at least 20 centimeters from all persons and not be co-located with any other transmitters except in accordance with FCC and Industry Canada multi-transmitter product procedures.

The end product with an embedded FCC ID: 2ABBXCM9209V402015 Module may also need to pass the FCC Part 15 unintentional emission testing requirements and be properly authorized per FCC Part 15

SPEC No.	Revision	State	C-MAX printed	Version	Page
CMM-9209-V4.0 2.4GHz Transceiver module	1.6	2015-02-25	2015-02-25	English	9 of 10

CMM-9209-V4.0

Long Range 2.4GHz Transceiver Module

C-MAX

The labeling instructions of finished products refer to following requirements:

A certified module has the option to use a permanently affixed label, or an electronic label (see Electronic Labeling below). For a permanently affixed label, the module must be labeled with an FCC ID - Section 2.926 (see Certification labeling requirements above). The OEM manual must provide clear instructions explaining to the OEM the labeling requirements, options and OEM user manual instructions that are required (see next paragraph).

For a host using a certified module with a standard fixed label, if (1) the module's FCC ID is not visible when installed in the host, or (2) if the host is marketed so that end users do not have straight forward commonly used methods for access to remove the module so that the FCC ID of the module is visible; then an additional permanent label referring to the enclosed module: "Contains FCC ID: 2ABXCM9209V402015" must be used. The host OEM user manual must also contain clear instructions on how end users can find and/or access the module and the FCC ID.

Other user manual statements may apply.

6. R&TTE Statement

Hereby, C-MAX Asia Limited declares that this CMM-9209-V4.0 is in compliance with the essential requirements and other relevant provisions of Directive 1999/5/EC.

Disclaimer of Warranty

Information furnished is believed to be accurate and reliable. However C-MAX assumes no responsibility, neither for the consequences of use of such information nor for any infringement of patents or other rights of third parties, which may result from its use. Specifications mentioned in this publication are subject to change without notice. This publication supersedes and replaces all information previously supplied. C-MAX products are not authorized for use as critical components in life support devices without express written approval of C-MAX.

Note

It is not given warranty that the declared circuits, devices, facilities, components, assembly groups or treatments included herein are free from legal claims of third parties. The declared data are serving only to description of product. They are not guaranteed properties as defined by law. The examples are given without obligation and cannot give rise to any liability.

Reprinting this data sheet - or parts of it - is only allowed with a license of the publisher.

C-MAX reserves the right to make changes on this specification without notice at any time.

C-MAX Asia Ltd

Unit 117, 1/F.,
Liven House,
61-63 King Yip Street,
Kwun Tong, Kowloon, HK SAR
Tel.: +852-2798-5182
Fax: +852-2798-5379
e-mail: enquiry@c-max.com.hk

C-MAX Technology Ltd (Shenzhen)

Room 922-923, 9/F.,
Kerry Centre,
2008 Reminnan Road,
Luohu District, Shenzhen, PR China,
Tel: +86-755-25181858
Fax: +86-755-25181859

SPEC No.	Revision	State	C-MAX printed	Version	Page
CMM-9209-V4.0 2.4GHz Transceiver module	1.6	2015-02-25	2015-02-25	English	10 of 10