

Notes:

1. DIMENSIONS AND TOLERANCES PER ASME Y14.5-2009
2. ALL DRAFT ANGLES 1 \* UNLESS OTHERWISE STATED
3. SEE CAD FOR FULL PRODUCT DEFINITION
4. MATERIAL: SILICONE RUBBER
5. TEXTURE:  
COSMETIC SURFACE: VDI 18  
OTHER SURFACES SPI-B2  
CROSS HATCHED AREA: SPI-A2
6. COLOR:  
BLACK: PANTONE 19-4007 TPX
7. ALL GATES TO BE TRIMMED SUBFLUSH
8. FLASH NOT TO EXCEED 0.02MM
9. PARTING LINE MISMATCH NOT TO EXCEED 5µm
10. DIMENSIONAL LIMITS APPLY AFTER COATING

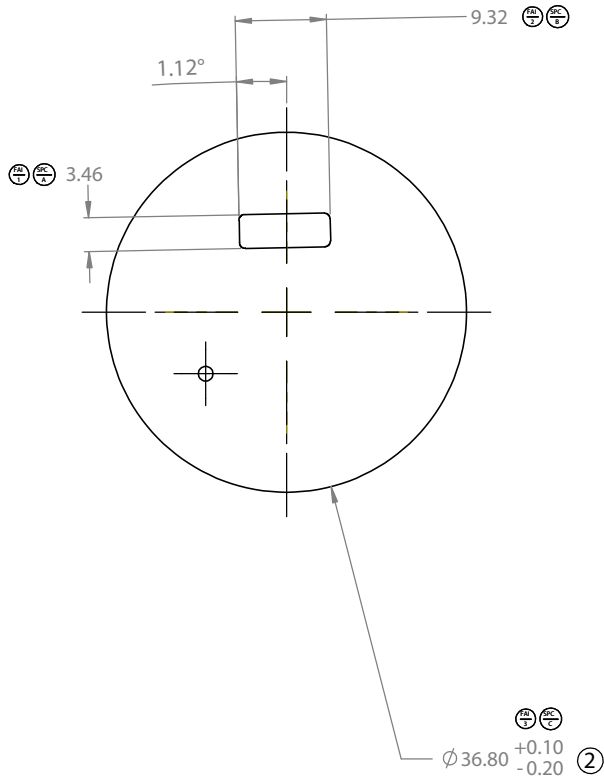

REVISIONS				
ZONE	REV.	DESCRIPTION	DATE	APPROVED
	1	INITIAL RELEASE	07/29/2016	AWT
B4	2	UPDATED TOLERANCE ON OUTER DIAMETER	8/23/16	AWT
	A	ADDED SPC AND FAI CALLOUTS FOR MP RELEASE FOR MP	10/6/16	AWT

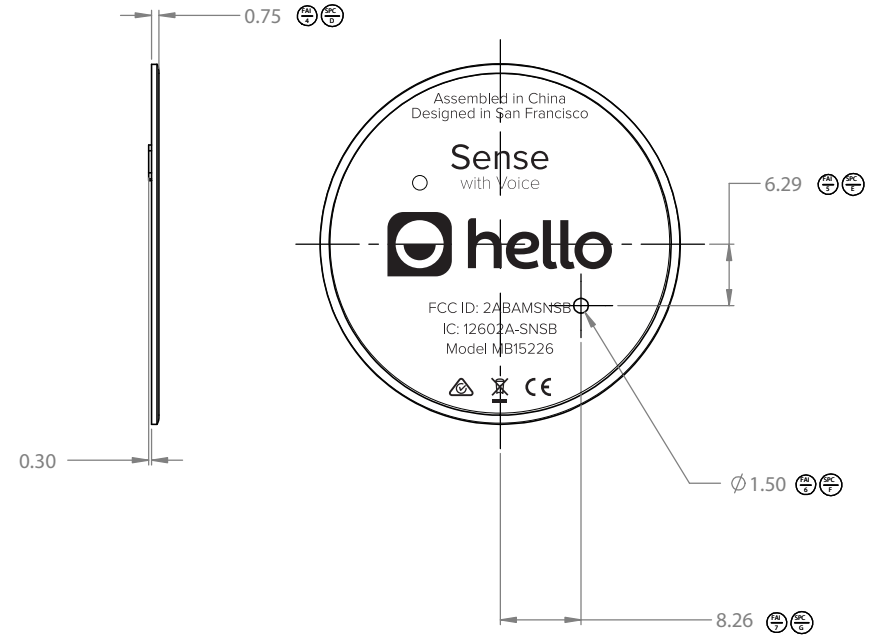

METRIC		DRAFTER	DATE	
DIMENSIONS ARE IN MILLIMETERS		DESIGNER	DATE	
TOLERANCES:				TITLE:
0 > - < 2	±0.05	<b>PROPRIETARY AND CONFIDENTIAL</b> THE INFORMATION CONTAINED IN THIS DRAWING IS THE SOLE PROPERTY OF HELLO INC.  ANY REPRODUCTION IN PART OR AS A WHOLE WITHOUT THE WRITTEN PERMISSION OF HELLO INC IS PROHIBITED.		<b>SILICONE RUBBER FOOT, SENSE 1.5, BLACK</b>
2 > - < 10	±0.08			SIZE <b>B</b> DWG. NO. <b>300-00066-03</b> REV <b>A</b>
10 > - < 50	±0.10			SCALE: 2:1 WEIGHT: SHEET 1 OF 1
50 > - < 100	±0.15			
100 > - < 200	±0.20			
200 > -	±0.20			
ANGLES	±1.00°			