

FCC Radio Test Report

FCC ID: 2AB9W-WE310F5P

Report No. : BTL-FCCP-1-2208T080
Equipment : 802.11 b/g/n WiFi Module
Model Name : WE310F5-P
Brand Name : Telit
Applicant : XYZprinting, Inc.
Address : 10F., No.99, Sec. 5, Nanjing E. Rd., Songshan Dist., Taipei City 10571, Taiwan (R.O.C.)

Radio Function : WLAN 2.4 GHz

FCC Rule Part(s) : FCC CFR Title 47, Part 15, Subpart C
Measurement Procedure(s) : ANSI C63.10-2013

Date of Receipt : 2022/8/25
Date of Test : 2022/8/25 ~ 2023/1/17
Issued Date : 2023/3/24

The above equipment has been tested and found in compliance with the requirement of the above standards by BTL Inc.

Prepared by : Eric Lee
Eric Lee, Engineer

Approved by : Jerry Chuang
Jerry Chuang, Supervisor

**BTL Inc.**

No.18, Ln. 171, Sec. 2, Jiuzong Rd., Neihu Dist., Taipei City 114, Taiwan

Tel: +886-2-2657-3299 Fax: +886-2-2657-3331 Web: www.newbtl.com Service mail: btl_qa@newbtl.com

Declaration

BTL represents to the client that testing is done in accordance with standard procedures as applicable and that test instruments used has been calibrated with standards traceable to international standard(s) and/or national standard(s).

BTL's reports apply only to the specific samples tested under conditions. It is manufacture's responsibility to ensure that additional production units of this model are manufactured with the identical electrical and mechanical components. **BTL** shall have no liability for any declarations, inferences or generalizations drawn by the client or others from **BTL** issued reports.

This report is the confidential property of the client. As a mutual protection to the clients, the public and ourselves, the test report shall not be reproduced, except in full, without our written approval.

BTL's laboratory quality assurance procedures are in compliance with the **ISO/IEC 17025** requirements, and accredited by the conformity assessment authorities listed in this test report.

BTL is not responsible for the sampling stage, so the results only apply to the sample as received.

The information, data and test plan are provided by manufacturer which may affect the validity of results, so it is manufacturer's responsibility to ensure that the apparatus meets the essential requirements of applied standards and in all the possible configurations as representative of its intended use.

Limitation

For the use of the authority's logo is limited unless the Test Standard(s)/Scope(s)/Item(s) mentioned in this test report is (are) included in the conformity assessment authorities acceptance respective.

Please note that the measurement uncertainty is provided for informational purpose only and are not use in determining the Pass/Fail results.

CONTENTS

1	SUMMARY OF TEST RESULTS	5
1.1	TEST FACILITY	6
1.2	MEASUREMENT UNCERTAINTY	6
1.3	TEST ENVIRONMENT CONDITIONS	6
1.4	TABLE OF PARAMETERS OF TEST SOFTWARE SETTING	7
2	GENERAL INFORMATION	8
2.1	DESCRIPTION OF EUT	8
2.2	TEST MODES	9
2.3	BLOCK DIAGRAM SHOWING THE CONFIGURATION OF SYSTEM TESTED	10
2.4	SUPPORT UNITS	10
3	AC POWER LINE CONDUCTED EMISSIONS TEST	11
3.1	LIMIT	11
3.2	TEST PROCEDURE	11
3.3	DEVIATION FROM TEST STANDARD	11
3.4	TEST SETUP	12
3.5	TEST RESULT	12
4	RADIATED EMISSIONS TEST	13
4.1	LIMIT	13
4.2	TEST PROCEDURE	14
4.3	DEVIATION FROM TEST STANDARD	14
4.4	TEST SETUP	15
4.5	EUT OPERATING CONDITIONS	16
4.6	TEST RESULT – BELOW 30 MHZ	16
4.7	TEST RESULT – 30 MHZ TO 1 GHZ	16
4.8	TEST RESULT – ABOVE 1 GHZ	16
5	OUTPUT POWER TEST	17
5.1	LIMIT	17
5.2	TEST PROCEDURE	17
5.3	DEVIATION FROM TEST STANDARD	17
5.4	TEST SETUP	17
5.5	EUT OPERATING CONDITIONS	17
5.6	TEST RESULT	17
6	LIST OF MEASURING EQUIPMENTS	18
7	EUT TEST PHOTO	19
8	EUT PHOTOS	19
APPENDIX A	AC POWER LINE CONDUCTED EMISSIONS	20
APPENDIX B	RADIATED EMISSIONS - 30 MHZ TO 1 GHZ	25
APPENDIX C	RADIATED EMISSIONS - ABOVE 1 GHZ	28
APPENDIX D	OUTPUT POWER	61

REVISION HISTORY

Report No.	Version	Description	Issued Date	Note
BTL-FCCP-1-2208T080	R00	Original Report.	2022/9/20	Invalid
BTL-FCCP-1-2208T080	R01	Revised Typo.	2022/10/6	Invalid
BTL-FCCP-1-2208T080	R02	Revised equipment name.	2022/10/11	Invalid
BTL-FCCP-1-2208T080	R03	Revised report to address TAF Audit's comments.	2023/3/24	Valid

1 SUMMARY OF TEST RESULTS

Test procedures according to the technical standards.

Standard(s) Section	Description	Test Result	Judgement	Remark
15.207	AC Power Line Conducted Emissions	APPENDIX A	Pass	-----
15.205 15.209 15.247(d)	Radiated Emissions	APPENDIX B APPENDIX C	Pass	-----
15.247(b)	Output Power	APPENDIX D	Pass	-----

NOTE:

- (1) "N/A" denotes test is not applicable in this Test Report.
- (2) The report format version is TP.1.1.1.
- (3) Accord to the EUT (Report Number: FR0N1118AA and model: WE310F5-P) has been certificated, AC power line conducted emissions, radiated emissions and output power were criticized and reconfirmed in this report.
- (4) Compared with the previous report (FR0N1118AA), Added two PCB type antennas.

1.1 TEST FACILITY

The test facilities used to collect the test data in this report:

No. 68-1, Ln. 169, Sec. 2, Datong Rd., Xizhi Dist., New Taipei City 221, Taiwan

The test sites and facilities are covered under FCC RN: 674415 and DN: TW0659.

- C05 CB08 CB11 CB15 CB16
 SR05

No. 72, Ln. 169, Sec. 2, Datong Rd., Xizhi Dist., New Taipei City 221, Taiwan

The test sites and facilities are covered under FCC RN: 674415 and DN: TW0659.

- C06 CB21 CB22

1.2 MEASUREMENT UNCERTAINTY

The reported uncertainty of measurement $y \pm U$, where expanded uncertainty U is based on a standard uncertainty multiplied by a coverage factor of $k = 2$, providing a level of confidence of approximately **95 %**. The measurement instrumentation uncertainty considerations contained in CISPR 16-4-2. The BTL measurement uncertainty is less than the CISPR 16-4-2 U_{cispr} requirement.

A. AC power line conducted emissions test:

Test Site	Method	Measurement Frequency Range	U (dB)
C05	CISPR	150 kHz ~ 30MHz	3.44

B. Radiated emissions test :

Test Site	Measurement Frequency Range	U,(dB)
CB21	0.03 GHz ~ 0.2 GHz	4.17
	0.2 GHz ~ 1 GHz	4.72
	1 GHz ~ 6 GHz	5.21
	6 GHz ~ 18 GHz	5.51
	18 GHz ~ 26 GHz	3.69
	26 GHz ~ 40 GHz	4.23

C. Conducted test :

Test Item	U,(dB)
Output Power	0.3669

NOTE:

Unless specifically mentioned, the uncertainty of measurement has not been taken into account to declare the compliance or non-compliance to the specification.

1.3 TEST ENVIRONMENT CONDITIONS

Test Item	Environment Condition	Test Voltage	Tested by
AC Power Line Conducted Emissions	21 °C, 52 %	AC 120V	Jay Tien
Radiated emissions below 1 GHz	Refer to data	AC 120V	Mark Wang
Radiated emissions above 1 GHz	Refer to data	AC 120V	Mark Wang
Output Power	24.1 °C, 47 %	AC 120V	Jay Tien

1.4 TABLE OF PARAMETERS OF TEST SOFTWARE SETTING

Test Software	UI_Mptool for AmebaD_2V2			
Mode	2412 MHz	2437 MHz	2462 MHz	Data Rate
IEEE 802.11b	91	92	91	1 Mbps
IEEE 802.11g	75	93	75	6 Mbps
IEEE 802.11n (HT20)	75	90	72	MCS 0
Modulation Mode	2422 MHz	2437 MHz	2452 MHz	Data Rate
IEEE 802.11n (HT40)	70	88	86	MCS 0

2 GENERAL INFORMATION

2.1 DESCRIPTION OF EUT

Equipment	802.11 b/g/n WiFi Module
Model Name	WE310F5-P
Brand Name	Telit
Model Difference	N/A
Power Source	DC Voltage supplied from host system.
Power Rating	DC 3.3V
Products Covered	N/A
Operation Band	2400 MHz ~ 2483.5 MHz
Operation Frequency	2412 MHz ~ 2462 MHz
Maximum Output Power	IEEE 802.11b: 17.31 dBm (0.0538 W) IEEE 802.11g: 15.94 dBm (0.0393 W) IEEE 802.11n (HT20): 15.69 dBm (0.0371 W) IEEE 802.11n (HT40): 15.23 dBm (0.0333 W)
Test Model	WE310F5-P
Sample Status	Engineering Sample
EUT Modification(s)	N/A

NOTE:

(1) The above EUT information is declared by manufacturer and for more detailed features description, please refers to the manufacturer's specifications or user's manual.

(2) Channel List:

Channel	Frequency (MHz)	Channel	Frequency (MHz)	Channel	Frequency (MHz)
01	2412	06	2437	11	2462
02	2417	07	2442		
03	2422	08	2447		
04	2427	09	2452		
05	2432	10	2457		

(3) Table for Filed Antenna:

Antenna	Brand	Part Number	Type	Connector	Frequency Range (MHz)	Gain (dBi)
1	WIESON	GY196HT0131C-002	PCB	I-PEX	2400-2500	3.56
2	WIESON	GY196HT0131C-010	PCB	I-PEX	2400-2500	0.38

NOTE: Antenna gain higher is used for testing.

(4) The above Antenna information are derived from the antenna data sheet provided by manufacturer and for more detailed features description, please refer to the manufacturer's specifications, the laboratory shall not be held responsible.

2.2 TEST MODES

Test Items	Test mode	Channel	Note
AC power line conducted emissions	Normal/Idle	-	-
Transmitter Radiated Emissions (below 1GHz)	IEEE 802.11n (HT20)	01	-
Transmitter Radiated Emissions (above 1GHz)	IEEE 802.11b	01/11	Bandedge
	IEEE 802.11g		
	IEEE 802.11n (HT20)	03/09	
	IEEE 802.11n (HT40)		
Transmitter Radiated Emissions (above 1GHz)	IEEE 802.11b	01/06/11	Harmonic
	IEEE 802.11g		
	IEEE 802.11n (HT20)	03/06/09	
	IEEE 802.11n (HT40)		
Output Power	IEEE 802.11b	01/06/11	-
	IEEE 802.11g		
	IEEE 802.11n (HT20)	03/06/09	
	IEEE 802.11n (HT40)		

NOTE:

- (1) The Radiated emissions test was verified based on the worst conducted power and Bandwidth test results reported in the original report.
- (2) For radiated emission band edge test, both Vertical and Horizontal are evaluated, but only the worst case (Vertical) is recorded.
- (3) All X, Y and Z axes are evaluated, but only the worst case (X axis) is recorded.

2.3 BLOCK DIAGRAM SHOWING THE CONFIGURATION OF SYSTEM TESTED

Equipment letters and Cable numbers refer to item numbers described in the tables of clause 0.

AC Power Line Conducted Emissions Test

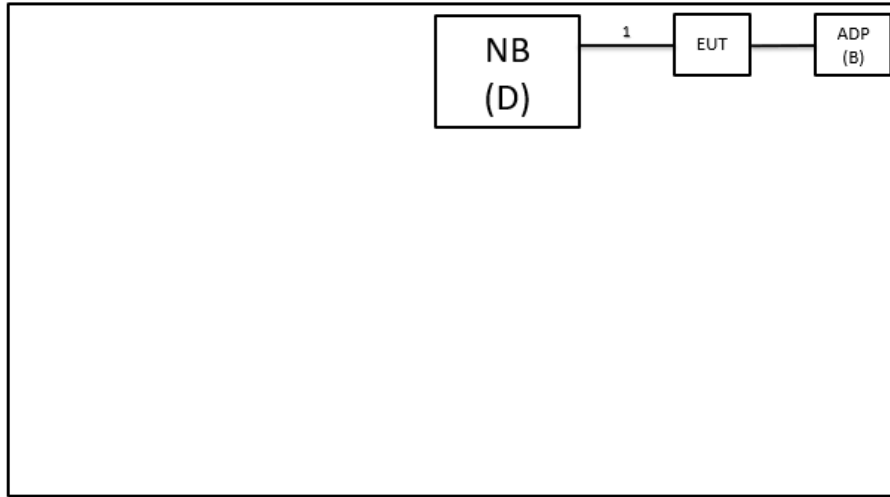

Radiated Emissions Test

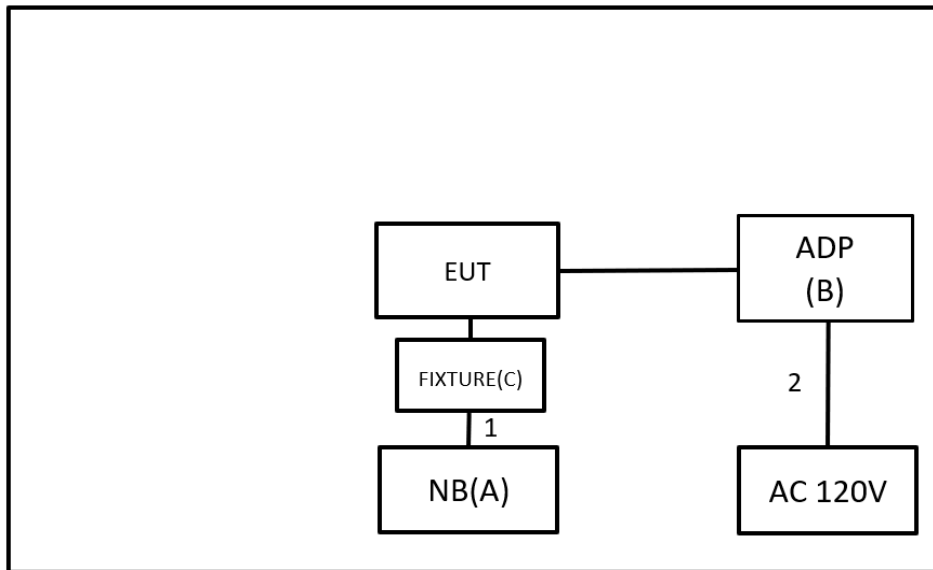

2.4 SUPPORT UNITS

Item	Equipment	Brand	Model No.	Series No.	Remarks
A	NB	Asus	B500-P45VA-0141 A3230M	N/A	Furnished by test lab.
B	Adapter	FSP GROUP INC	FSP120-AAAN3	N/A	Supplied by test requester.
C	Fixture	RXG 3.3 TX	N/A	N/A	Supplied by test requester.
D	NB	ASUS	X450J	N/A	Furnished by test lab.

Item	Shielded	Ferrite Core	Length	Cable Type	Remarks
1	N/A	N/A	1.8m	USB Cable	Supplied by test requester.
2	N/A	N/A	1.5m	Power Code	Supplied by test requester.

3 AC POWER LINE CONDUCTED EMISSIONS TEST

3.1 LIMIT

Frequency (MHz)	Limit (dB μ V)	
	Quasi-peak	Average
0.15 - 0.5	66 - 56 *	56 - 46 *
0.50 - 5.0	56	46
5.0 - 30.0	60	50

NOTE:

- (1) The tighter limit applies at the band edges.
- (2) The limit of " * " marked band means the limitation decreases linearly with the logarithm of the frequency in the range.
- (3) The test result calculated as following:
 Measurement Value = Reading Level + Correct Factor
 Correct Factor = Insertion Loss + Cable Loss + Attenuator Factor (if use)
 Margin Level = Measurement Value – Limit Value
 Calculation example:

Reading Level		Correct Factor		Measurement Value
38.22	+	3.45	=	41.67

Measurement Value		Limit Value		Margin Level
41.67	-	60	=	-18.33

The following table is the setting of the receiver.

Receiver Parameter	Setting
Attenuation	10 dB
Start Frequency	0.15 MHz
Stop Frequency	30 MHz
IF Bandwidth	9 KHz

3.2 TEST PROCEDURE

- a. The EUT was placed 0.8 m above the horizontal ground plane with the EUT being connected to the power mains through a line impedance stabilization network (LISN).
 All other support equipment were powered from an additional LISN(s).
 The LISN provides 50 Ohm/50uH of impedance for the measuring instrument.
- b. Interconnecting cables that hang closer than 40 cm to the ground plane shall be folded back and forth in the center forming a bundle to keep the cable above 40 cm.
- c. Excess I/O cables that are not connected to a peripheral shall be bundled in the center.
 The end of the cable will be terminated, using the correct terminating impedance.
 The overall length shall not exceed 1 m.
- d. The LISN is spaced at least 80 cm from the nearest part of the EUT chassis.
- e. For the actual test configuration, please refer to the related Item - EUT TEST PHOTO.

NOTE:

- (1) In the results, each reading is marked as Peak, QP or AVG per the detector used.
 BW=9 kHz (6 dB Bandwidth)
- (2) All readings are Peak unless otherwise stated QP or AVG in column of Note. Both the QP and the AVG readings must be less than the limit for compliance.

3.3 DEVIATION FROM TEST STANDARD

No deviation.

3.4 TEST SETUP

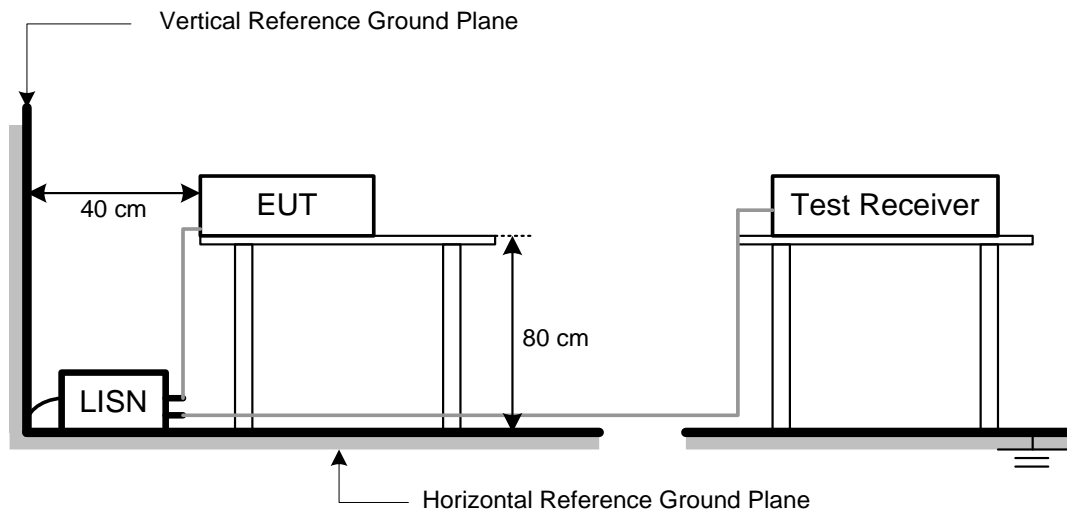

3.5 TEST RESULT

Please refer to the APPENDIX A.

4 RADIATED EMISSIONS TEST

4.1 LIMIT

In case the emission fall within the restricted band specified on 15.205, then the 15.209 limit in the table below has to be followed.

LIMITS OF RADIATED EMISSIONS MEASUREMENT (9 kHz to 1000 MHz)

Frequency (MHz)	Field Strength (microvolts/meter)	Measurement Distance (meters)
0.009~0.490	2400/F(KHz)	300
0.490~1.705	24000/F(KHz)	30
1.705~30.0	30	30
30~88	100	3
88~216	150	3
216~960	200	3
960~1000	500	3

LIMITS OF RADIATED EMISSIONS MEASUREMENT (Above 1000 MHz)

Frequency (MHz)	Radiated Emissions (dBuV/m)		Measurement Distance (meters)
	Peak	Average	
Above 1000	74	54	3

NOTE:

- (1) The limit for radiated test was performed according to FCC Part 15, Subpart C.
- (2) The tighter limit applies at the band edges.
- (3) Emission level (dBuV/m)=20log Emission level (uV/m).
- (4) The test result calculated as following:

Measurement Value = Reading Level + Correct Factor

Correct Factor = Antenna Factor + Cable Loss - Amplifier Gain(if use)

Margin Level = Measurement Value - Limit Value

Calculation example:

Reading Level		Correct Factor		Measurement Value
19.11	+	2.11	=	21.22

Measurement Value		Limit Value		Margin Level
21.22	-	54	=	-32.78

Spectrum Parameter	Setting
Attenuation	Auto
Start Frequency	1000 MHz
Stop Frequency	10th carrier harmonic
RBW / VBW (Emission in restricted band)	1MHz / 3MHz for Peak, 1MHz / 1/T for Average

Spectrum Parameter	Setting
Attenuation	Auto
Start ~ Stop Frequency	9KHz~90KHz for PK/AVG detector
Start ~ Stop Frequency	90KHz~110KHz for QP detector
Start ~ Stop Frequency	110KHz~490KHz for PK/AVG detector
Start ~ Stop Frequency	490KHz~30MHz for QP detector
Start ~ Stop Frequency	30MHz~1000MHz for QP detector

4.2 TEST PROCEDURE

- a. The measuring distance of 3 m shall be used for measurements. The EUT was placed on the top of a rotating table 0.8 meter above the ground at a 3 meter semi-anechoic chamber. The table was rotated 360 degrees to determine the position of the highest radiation.(below 1GHz)
- b. The measuring distance of 3 m shall be used for measurements. The EUT was placed on the top of a rotating table 1.5 meter above the ground at a 3 meter semi-anechoic chamber. The table was rotated 360 degrees to determine the position of the highest radiation.(above 1GHz)
- c. The height of the equipment or of the substitution antenna shall be 0.8 m or 1.5 m, the height of the test antenna shall vary between 1 m to 4 m. Both horizontal and vertical polarizations of the antenna are set to make the measurement.
- d. For each suspected emission, the EUT was arranged to its worst case and then the antenna was tuned to heights find the maximum reading (used Bore sight function).
- e. The receiver system was set to peak and average detect function and specified bandwidth with maximum hold mode when the test frequency is above 1GHz.
- f. The initial step in collecting radiated emission data is a receiver peak detector mode pre-scanning the measurement frequency range. Significant peaks are then marked and then Quasi Peak detector mode re-measured.
- g. All readings are Peak unless otherwise stated QP in column of Note. Peak denotes that the Peak reading compliance with the QP Limits and then QP Mode measurement didn't perform. (below 1GHz)
- h. All readings are Peak Mode value unless otherwise stated AVG in column of Note. If the Peak Mode Measured value compliance with the Peak Limits and lower than AVG Limits, the EUT shall be deemed to meet both Peak & AVG Limits and then only Peak Mode was measured, but AVG Mode didn't perform. (above 1GHz)
- i. For the actual test configuration, please refer to the related Item – EUT TEST PHOTO.

4.3 DEVIATION FROM TEST STANDARD

No deviation.

4.4 TEST SETUP

9 kHz to 30 MHz

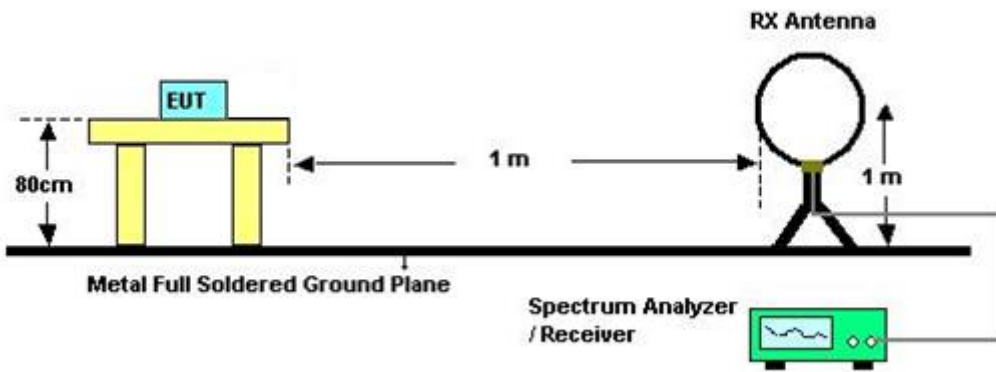

30 MHz to 1 GHz

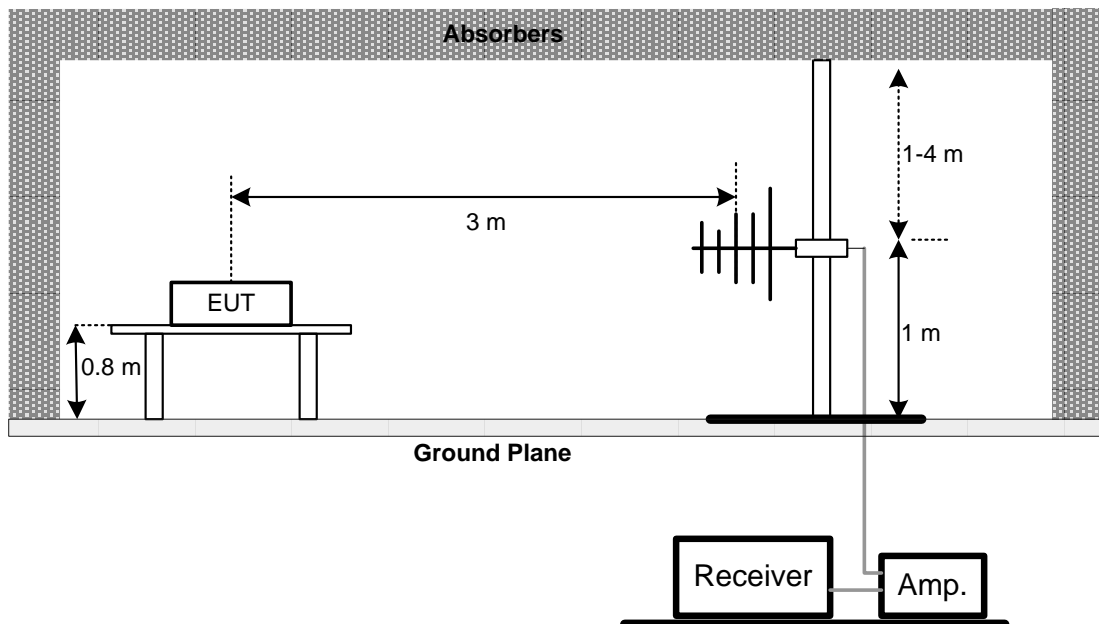

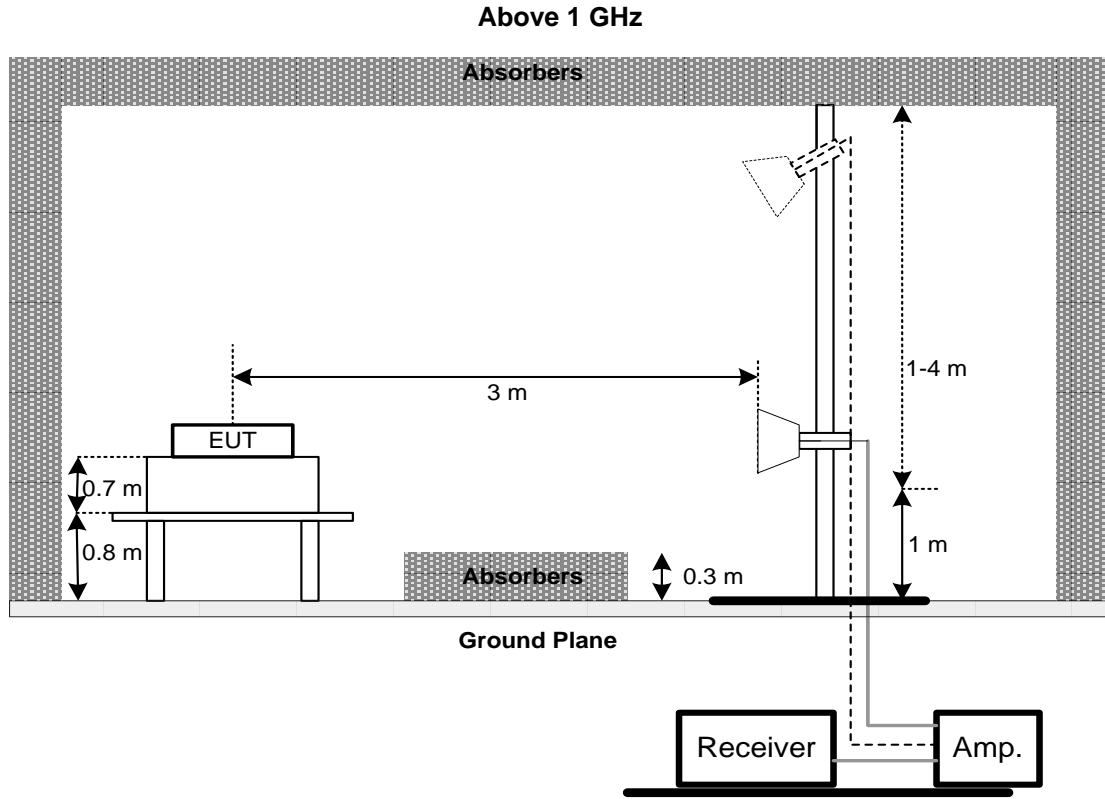

4.5 EUT OPERATING CONDITIONS

The EUT was programmed to be in continuously transmitting mode.

NOTE:

- (1) Distance extrapolation factor = $40 \log (\text{specific distance} / \text{test distance})$ (dB).
- (2) Limit line = specific limits (dBuV) + distance extrapolation factor.

4.6 TEST RESULT – BELOW 30 MHZ

There were no emissions found below 30 MHz within 20 dB of the limit.

4.7 TEST RESULT – 30 MHZ TO 1 GHZ

Please refer to the APPENDIX B.

4.8 TEST RESULT – ABOVE 1 GHZ

Please refer to the APPENDIX C.

NOTE:

- (1) No limit: This is fundamental signal, the judgment is not applicable. For fundamental signal judgment was referred to Peak output test.

5 OUTPUT POWER TEST

5.1 LIMIT

FCC Part15, Subpart C (15.247)		
Section	Test Item	Limit
15.247(b)	Maximum Output Power	1 Watt or 30dBm

5.2 TEST PROCEDURE

- a. The EUT was directly connected to the power meter and antenna output port as show in the block diagram below.
- b. The maximum peak conducted output power was performed in accordance with FCC KDB 558074 D01 15.247 Meas Guidance.
- c. Subclause 11.9.1.1 of ANSI C63.10 is applied. The maximum peak conducted output power may be measured using a broadband peak RF power meter.
The power meter shall have a video bandwidth that is greater than or equal to the DTS bandwidth and shall use a fast-responding diode detector.

5.3 DEVIATION FROM TEST STANDARD

No deviation.

5.4 TEST SETUP

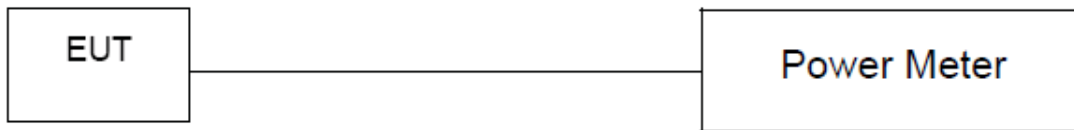

5.5 EUT OPERATING CONDITIONS

The EUT was programmed to be in continuously transmitting mode.

5.6 TEST RESULT

Please refer to the APPENDIX D.

6 LIST OF MEASURING EQUIPMENTS

AC Power Line Conducted Emissions						
Item	Kind of Equipment	Manufacturer	Type No.	Serial No.	Calibrated Date	Calibrated Until
1	TWO-LINE V-NETWORK	R&S	ENV216	101051	2022/6/15	2023/6/14
2	Test Cable	EMCI	EMCRG58-BM-B M-9000	210501	2022/5/2	2023/5/1
3	EMI Test Receiver	R&S	ESR 7	101433	2021/11/24	2022/11/23
4	Measurement Software	EZ	EZ_EMC (Version NB-03A1-01)	N/A	N/A	N/A

Radiated Emissions						
Item	Kind of Equipment	Manufacturer	Type No.	Serial No.	Calibrated Date	Calibrated Until
1	Preamplifier	EMCI	EMC330N	980850	2021/9/23	2022/9/22
					2022/9/19	2023/9/18
2	Preamplifier	EMCI	EMC118A45SE	980819	2022/3/8	2023/3/7
3	Preamplifier	EMCI	EMC001340	980555	2022/4/6	2023/4/5
4	Test Cable	EMCI	EMC104-SM-SM-1000	220319	2022/3/15	2023/3/14
5	Test Cable	EMCI	EMC104-SM-SM-3000	220322	2022/3/15	2023/3/14
6	Test Cable	EMCI	EMC104-SM-SM-7000	220324	2022/3/15	2023/3/14
7	EXA Signal Analyzer	keysight	N9020A	MY57120120	2022/3/7	2023/3/6
8	Loop Ant	Electro-Metrics	EMCI-LPA600	274	2022/6/16	2023/6/15
9	Horn Antenna	RFSPIN	DRH18-E	211202A18EN	2022/5/18	2023/5/17
10	Horn Ant	Schwarzbeck	BBHA 9170D	1136	2022/5/18	2023/5/17
11	Log-bicon Antenna	Schwarzbeck	VULB9168	1369	2022/5/20	2023/5/19
12	6dB Attenuator	EMCI	EMCI-N-6-06	AT-N0625	2022/5/20	2023/5/19
13	Measurement Software	EZ	EZ_EMC (Version NB-03A1-01)	N/A	N/A	N/A

Output Power						
Item	Kind of Equipment	Manufacturer	Type No.	Serial No.	Calibrated Date	Calibrated Until
1	Spectrum Analyzer	Keysight	N9010A	MY54200240	2022/6/9	2023/6/8
2	Power Meter	Keysight	8990B	MY51000517	2022/3/18	2023/3/17
3	Power Sensor	Keysight	N1923A	MY58310005	2022/3/18	2023/3/17

Remark: "N/A" denotes no model name, no serial no. or no calibration specified.
All calibration period of equipment list is one year.

7 EUT TEST PHOTO

Please refer to document Appendix No.: TP-2208T080-FCCP-1 (APPENDIX-TEST PHOTOS).

8 EUT PHOTOS

Please refer to document Appendix No.: EP-2208T080-1 (APPENDIX-EUT PHOTOS).

APPENDIX A AC POWER LINE CONDUCTED EMISSIONS

Test Mode	Normal	Tested Date	2022/9/2
Test Frequency	-	Phase	Line

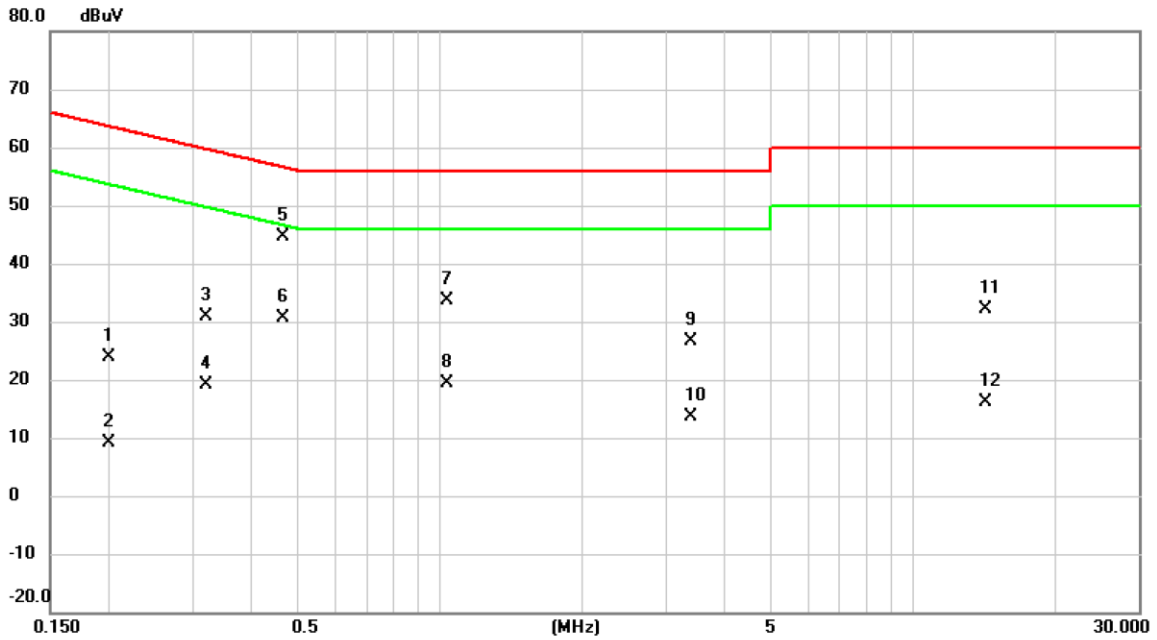

No.	Mk.	Freq. MHz	Reading Level dBuV	Correct Factor dB	Measure- ment dBuV	Limit dBuV	Margin dB	Detector	Comment
1		0.1996	14.26	9.63	23.89	63.63	-39.74	QP	
2		0.1996	-0.50	9.63	9.13	53.63	-44.50	AVG	
3		0.3210	21.22	9.62	30.84	59.68	-28.84	QP	
4		0.3210	9.48	9.62	19.10	49.68	-30.58	AVG	
5	*	0.4650	35.12	9.62	44.74	56.60	-11.86	QP	
6		0.4650	20.91	9.62	30.53	46.60	-16.07	AVG	
7		1.0363	23.89	9.66	33.55	56.00	-22.45	QP	
8		1.0363	9.79	9.66	19.45	46.00	-26.55	AVG	
9		3.3990	16.87	9.73	26.60	56.00	-29.40	QP	
10		3.3990	3.86	9.73	13.59	46.00	-32.41	AVG	
11		14.2665	22.33	9.83	32.16	60.00	-27.84	QP	
12		14.2665	6.30	9.83	16.13	50.00	-33.87	AVG	

REMARKS:

- (1) Measurement Value = Reading Level + Correct Factor.
- (2) Margin Level = Measurement Value - Limit Value.

Test Mode	Normal	Tested Date	2022/9/2
Test Frequency	-	Phase	Neutral

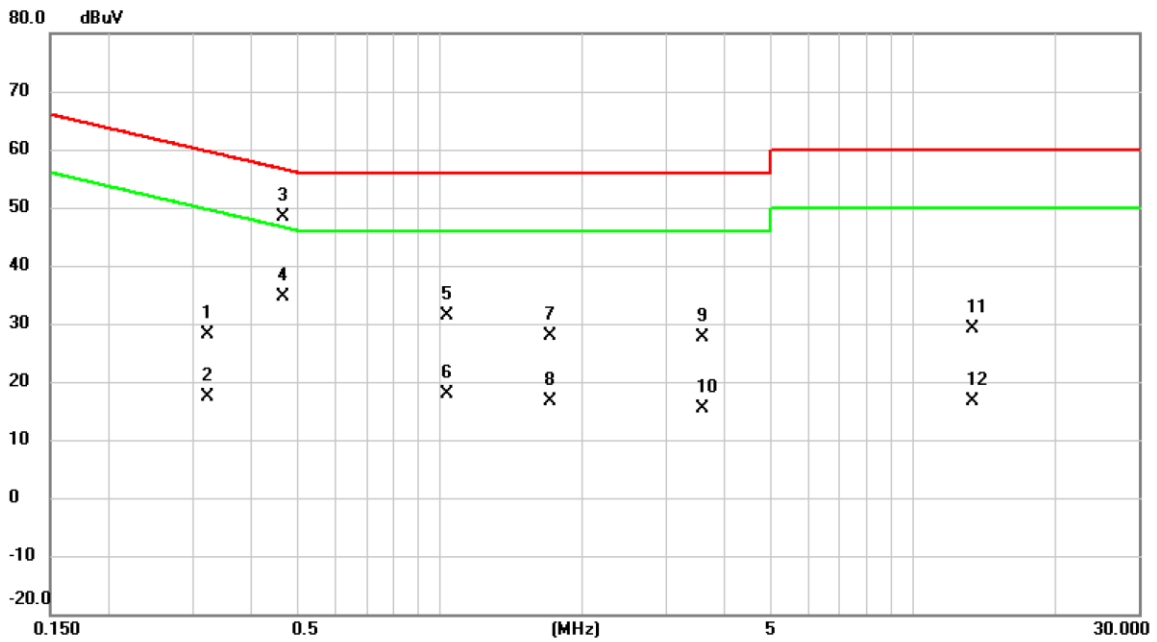

No.	Mk.	Freq. MHz	Reading Level dBuV	Correct Factor dB	Measure- ment dBuV	Limit dBuV	Margin dB	Detector	Comment
1		0.3232	18.60	9.62	28.22	59.62	-31.40	QP	
2		0.3232	7.71	9.62	17.33	49.62	-32.29	AVG	
3	*	0.4650	38.84	9.62	48.46	56.60	-8.14	QP	
4		0.4650	25.09	9.62	34.71	46.60	-11.89	AVG	
5		1.0365	21.65	9.66	31.31	56.00	-24.69	QP	
6		1.0365	8.23	9.66	17.89	46.00	-28.11	AVG	
7		1.7160	18.27	9.68	27.95	56.00	-28.05	QP	
8		1.7160	6.90	9.68	16.58	46.00	-29.42	AVG	
9		3.5790	17.85	9.74	27.59	56.00	-28.41	QP	
10		3.5790	5.52	9.74	15.26	46.00	-30.74	AVG	
11		13.3778	19.15	9.90	29.05	60.00	-30.95	QP	
12		13.3778	6.65	9.90	16.55	50.00	-33.45	AVG	

REMARKS:
 (1) Measurement Value = Reading Level + Correct Factor.
 (2) Margin Level = Measurement Value - Limit Value.

Test Mode	Idle	Tested Date	2022/9/2
Test Frequency	-	Phase	Line

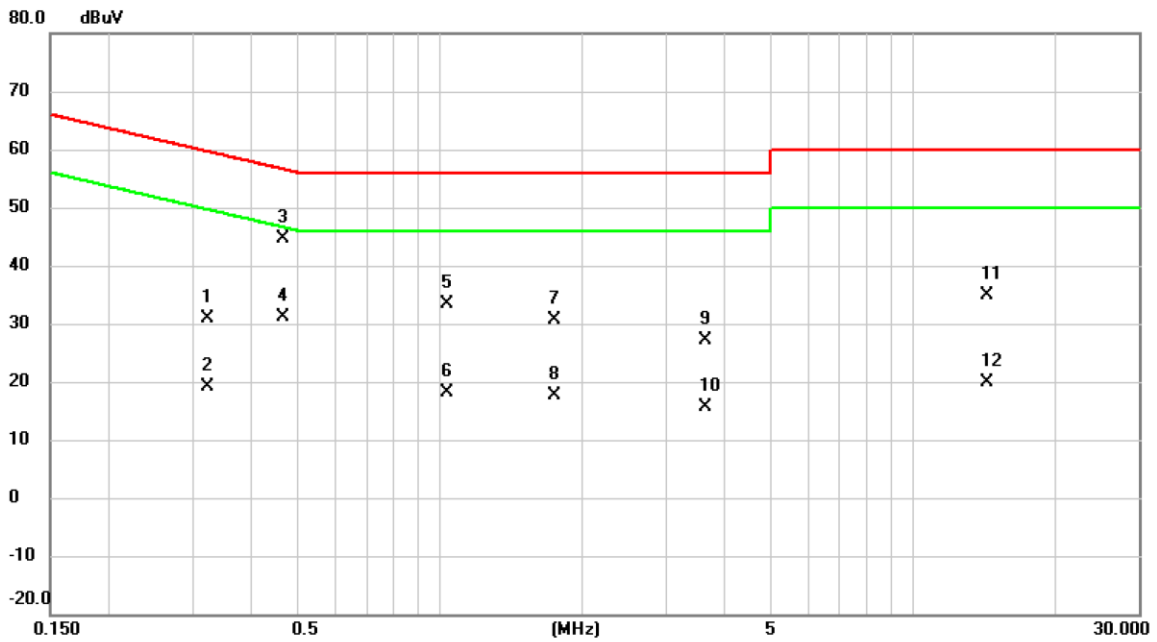

No.	Mk.	Freq. MHz	Reading Level dBuV	Correct Factor dB	Measure- ment dBuV	Limit dBuV	Margin dB	Detector	Comment
1		0.3232	21.15	9.62	30.77	59.62	-28.85	QP	
2		0.3232	9.45	9.62	19.07	49.62	-30.55	AVG	
3	*	0.4650	35.13	9.62	44.75	56.60	-11.85	QP	
4		0.4650	21.58	9.62	31.20	46.60	-15.40	AVG	
5		1.0365	23.76	9.66	33.42	56.00	-22.58	QP	
6		1.0365	8.55	9.66	18.21	46.00	-27.79	AVG	
7		1.7520	20.94	9.69	30.63	56.00	-25.37	QP	
8		1.7520	7.89	9.69	17.58	46.00	-28.42	AVG	
9		3.6510	17.29	9.74	27.03	56.00	-28.97	QP	
10		3.6510	5.77	9.74	15.51	46.00	-30.49	AVG	
11		14.3183	25.08	9.83	34.91	60.00	-25.09	QP	
12		14.3183	10.08	9.83	19.91	50.00	-30.09	AVG	

REMARKS:

- (1) Measurement Value = Reading Level + Correct Factor.
- (2) Margin Level = Measurement Value - Limit Value.

Test Mode	Idle	Tested Date	2022/9/2
Test Frequency	-	Phase	Neutral

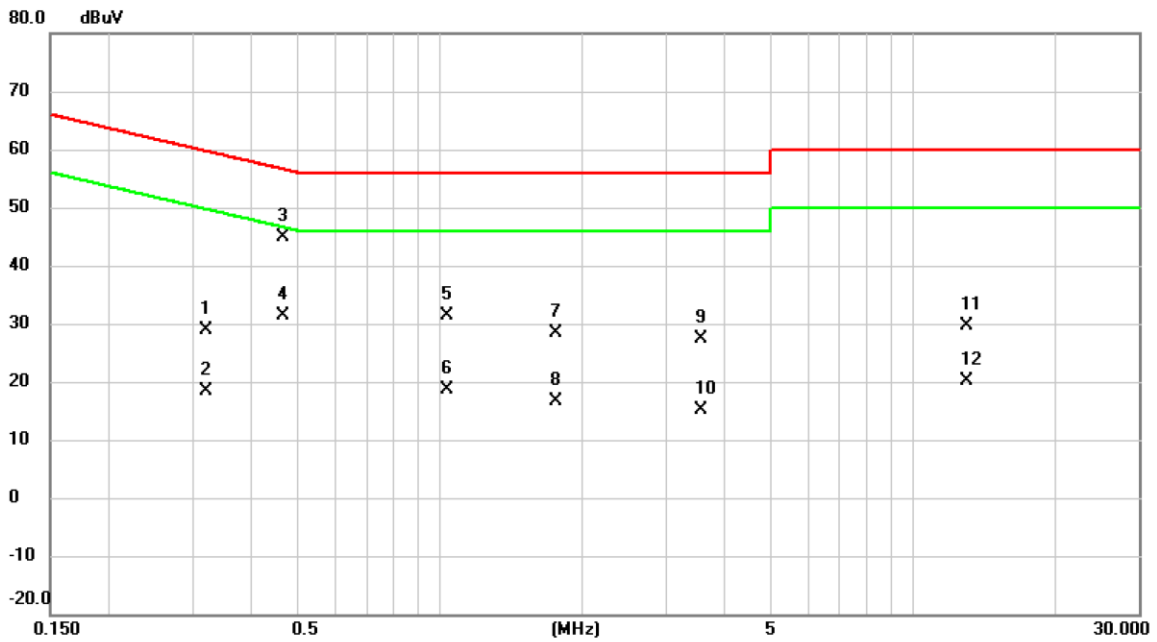

No.	Mk.	Freq. MHz	Reading Level dBuV	Correct Factor dB	Measure- ment dBuV	Limit dBuV	Margin dB	Detector	Comment
1		0.3210	19.17	9.62	28.79	59.68	-30.89	QP	
2		0.3210	8.87	9.62	18.49	49.68	-31.19	AVG	
3	*	0.4650	35.36	9.62	44.98	56.60	-11.62	QP	
4		0.4650	21.73	9.62	31.35	46.60	-15.25	AVG	
5		1.0387	21.65	9.66	31.31	56.00	-24.69	QP	
6		1.0387	8.86	9.66	18.52	46.00	-27.48	AVG	
7		1.7543	18.60	9.69	28.29	56.00	-27.71	QP	
8		1.7543	6.86	9.69	16.55	46.00	-29.45	AVG	
9		3.5768	17.67	9.74	27.41	56.00	-28.59	QP	
10		3.5768	5.45	9.74	15.19	46.00	-30.81	AVG	
11		12.9953	19.68	9.90	29.58	60.00	-30.42	QP	
12		12.9953	10.17	9.90	20.07	50.00	-29.93	AVG	

REMARKS:
 (1) Measurement Value = Reading Level + Correct Factor.
 (2) Margin Level = Measurement Value - Limit Value.

APPENDIX B RADIATED EMISSIONS - 30 MHZ TO 1 GHZ

Test Mode	IEEE 802.11b	Test Date	2023/1/17
Test Frequency	2412MHz	Polarization	Vertical
Temp	23°C	Hum.	59%

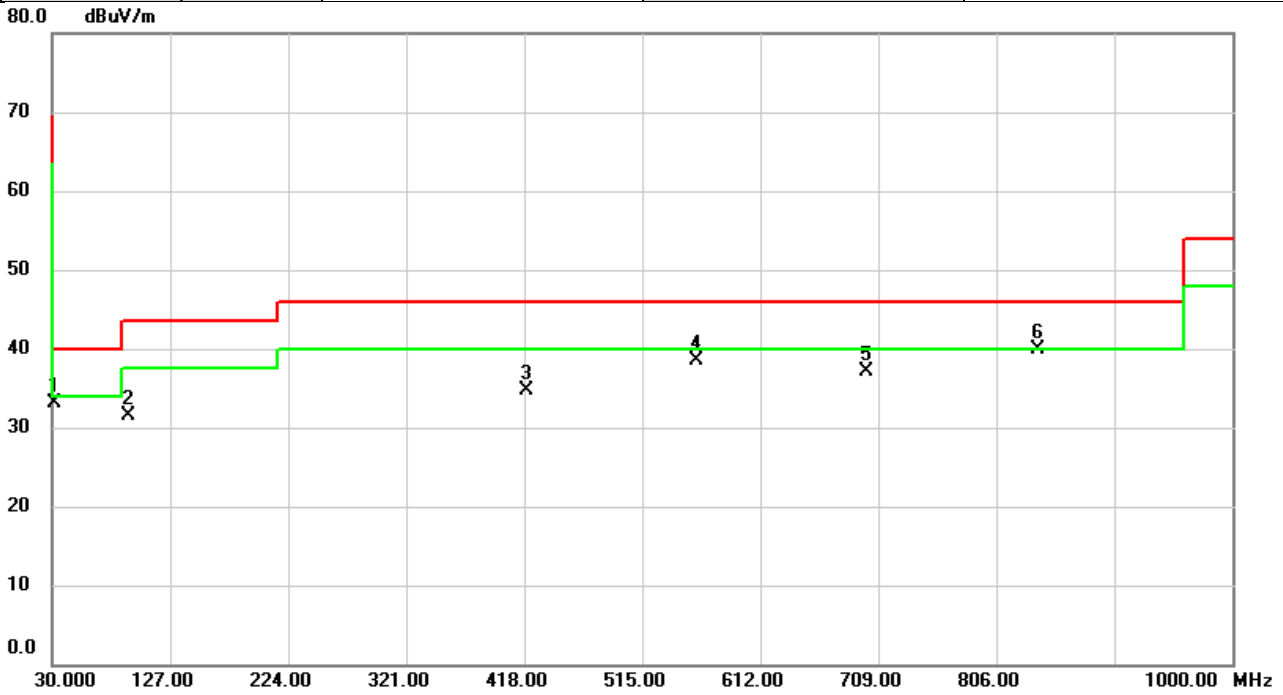

No.	Mk.	Freq.	Reading Level	Correct Factor	Measurement	Limit	Over	Detector	Comment
		MHz	dBuV	dB	dBuV/m	dBuV/m	dB		
1		31.5520	45.70	-12.69	33.01	40.00	-6.99	peak	
2		92.9207	48.64	-17.19	31.45	43.50	-12.05	peak	
3		419.8753	42.93	-8.23	34.70	46.00	-11.30	peak	
4		559.7817	43.74	-5.32	38.42	46.00	-7.58	peak	
5		699.7850	39.94	-2.89	37.05	46.00	-8.95	peak	
6	*	839.7560	40.44	-0.56	39.88	46.00	-6.12	peak	

REMARKS:

- (1) Measurement Value = Reading Level + Correct Factor.
- (2) Margin Level = Measurement Value - Limit Value.

Test Mode	IEEE 802.11b	Test Date	2023/1/17
Test Frequency	2412MHz	Polarization	Horizontal
Temp	23°C	Hum.	59%

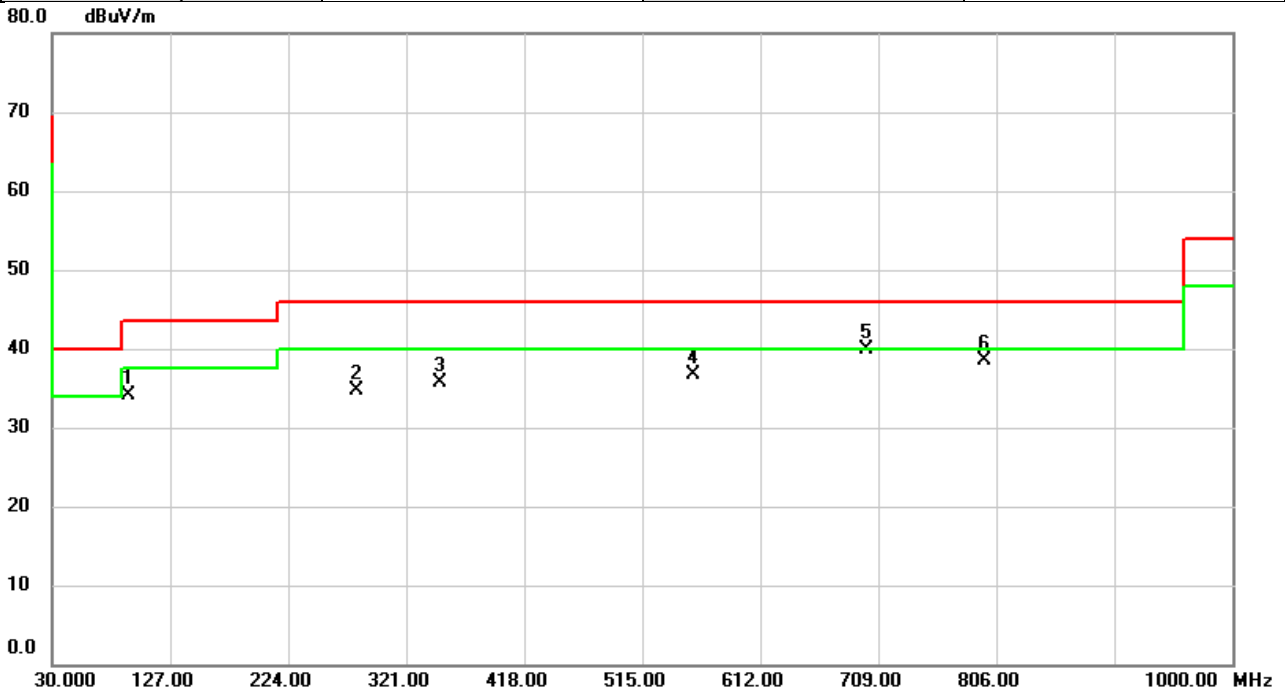

No.	Mk.	Freq.	Reading Level	Correct Factor	Measurement	Limit	Over	Detector	Comment
		MHz	dBuV	dB	dBuV/m	dBuV/m	dB		
1		93.2440	51.30	-17.15	34.15	43.50	-9.35	peak	
2		279.8397	46.55	-11.91	34.64	46.00	-11.36	peak	
3		348.8713	46.18	-10.38	35.80	46.00	-10.20	peak	
4		557.5830	42.04	-5.38	36.66	46.00	-9.34	peak	
5	*	699.8497	42.80	-2.89	39.91	46.00	-6.09	peak	
6		796.5910	39.70	-1.12	38.58	46.00	-7.42	peak	

REMARKS:

- (1) Measurement Value = Reading Level + Correct Factor.
- (2) Margin Level = Measurement Value - Limit Value.

APPENDIX C RADIATED EMISSIONS - ABOVE 1 GHZ

Test Mode	IEEE 802.11b	Test Date	2022/9/6
Test Frequency	2412MHz	Polarization	Vertical
Temp	26°C	Hum.	60%

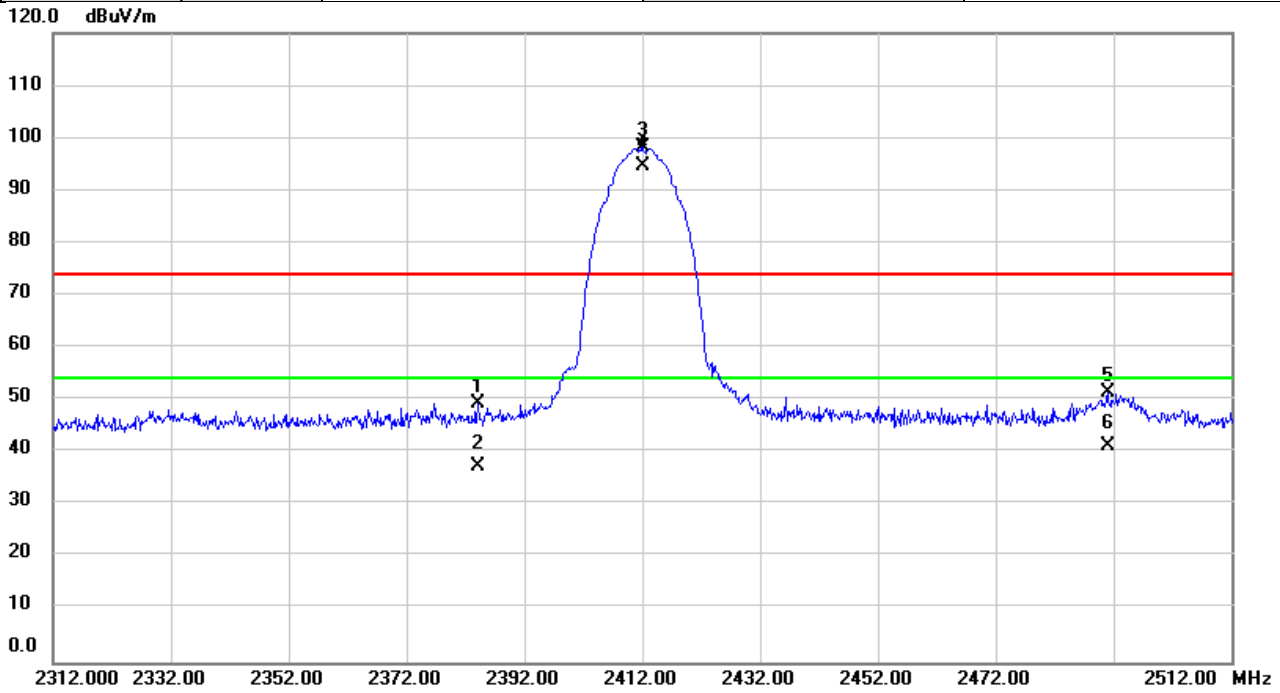

No.	Mk.	Freq. MHz	Reading Level dBuV	Correct Factor dB	Measure- ment dBuV/m	Limit dBuV/m	Over dB	Detector	Comment
1		2384.193	55.07	-5.78	49.29	74.00	-24.71	peak	
2		2384.193	43.26	-5.78	37.48	54.00	-16.52	AVG	
3	X	2412.000	104.02	-5.74	98.28	74.00	24.28	peak	NoLimit
4	*	2412.000	100.43	-5.74	94.69	54.00	40.69	AVG	NoLimit
5		2490.967	57.17	-5.63	51.54	74.00	-22.46	peak	
6		2490.967	47.00	-5.63	41.37	54.00	-12.63	AVG	

REMARKS:

- (1) Measurement Value = Reading Level + Correct Factor.
- (2) Margin Level = Measurement Value - Limit Value.

Test Mode	IEEE 802.11b	Test Date	2022/9/6
Test Frequency	2462MHz	Polarization	Vertical
Temp	26°C	Hum.	60%

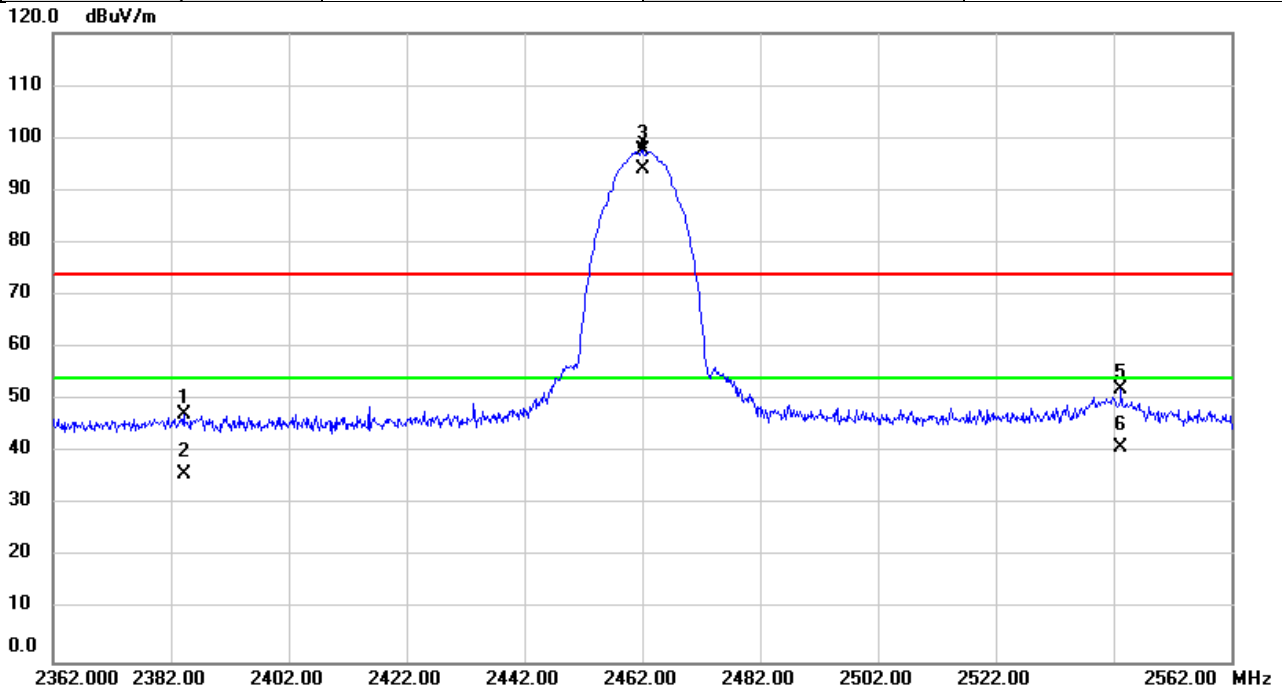

No.	Mk.	Freq.	Reading Level	Correct Factor	Measurement	Limit	Over	Detector	Comment
		MHz	dBuV	dB	dBuV/m	dBuV/m	dB		
1		2384.153	52.98	-5.78	47.20	74.00	-26.80	peak	
2		2384.153	41.56	-5.78	35.78	54.00	-18.22	AVG	
3	X	2462.000	103.38	-5.68	97.70	74.00	23.70	peak	NoLimit
4	*	2462.000	99.73	-5.68	94.05	54.00	40.05	AVG	NoLimit
5		2543.300	57.38	-5.43	51.95	74.00	-22.05	peak	
6		2543.300	46.44	-5.43	41.01	54.00	-12.99	AVG	

REMARKS:

- (1) Measurement Value = Reading Level + Correct Factor.
- (2) Margin Level = Measurement Value - Limit Value.

Test Mode	IEEE 802.11g	Test Date	2022/9/6
Test Frequency	2412MHz	Polarization	Vertical
Temp	26°C	Hum.	60%

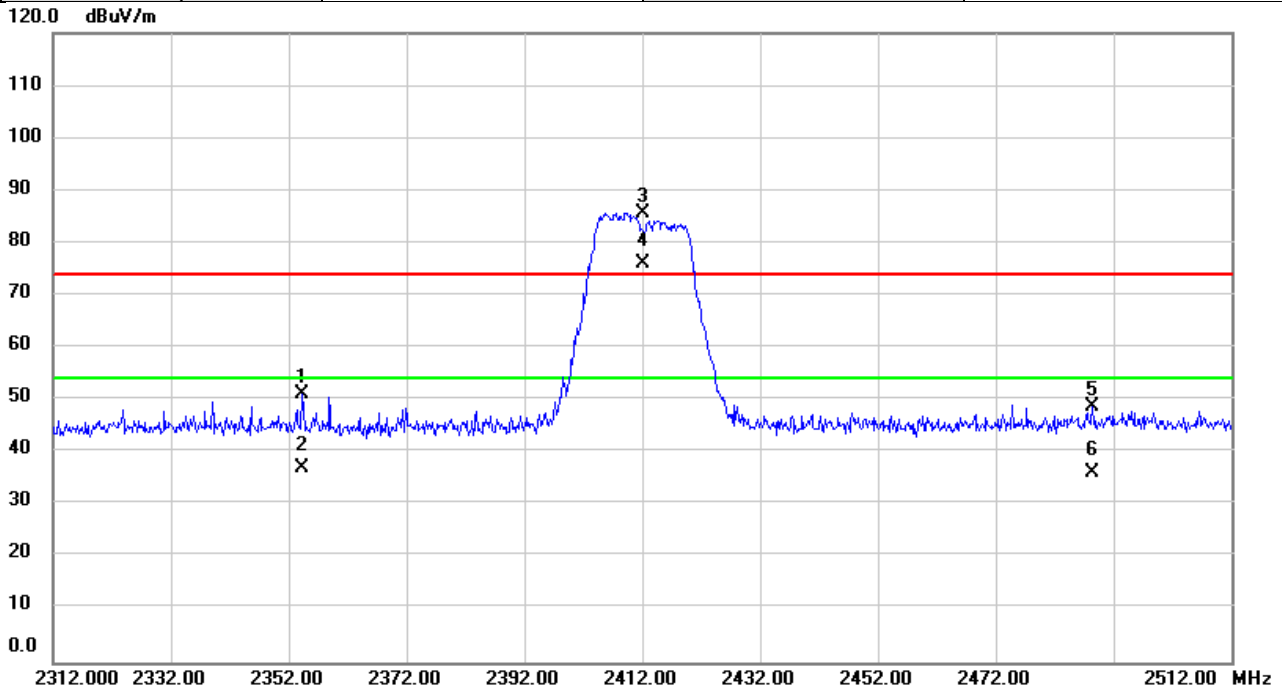

No.	Mk.	Freq.	Reading Level	Correct Factor	Measurement	Limit	Over	Detector	Comment
		MHz	dBuV	dB	dBuV/m	dBuV/m	dB		
1		2354.373	56.86	-5.82	51.04	74.00	-22.96	peak	
2		2354.373	42.74	-5.82	36.92	54.00	-17.08	AVG	
3	X	2412.000	91.43	-5.74	85.69	74.00	11.69	peak	NoLimit
4	*	2412.000	81.89	-5.74	76.15	54.00	22.15	AVG	NoLimit
5		2488.440	54.45	-5.63	48.82	74.00	-25.18	peak	
6		2488.440	41.88	-5.63	36.25	54.00	-17.75	AVG	

REMARKS:

- (1) Measurement Value = Reading Level + Correct Factor.
- (2) Margin Level = Measurement Value - Limit Value.

Test Mode	IEEE 802.11g	Test Date	2022/9/6
Test Frequency	2462MHz	Polarization	Vertical
Temp	26°C	Hum.	60%

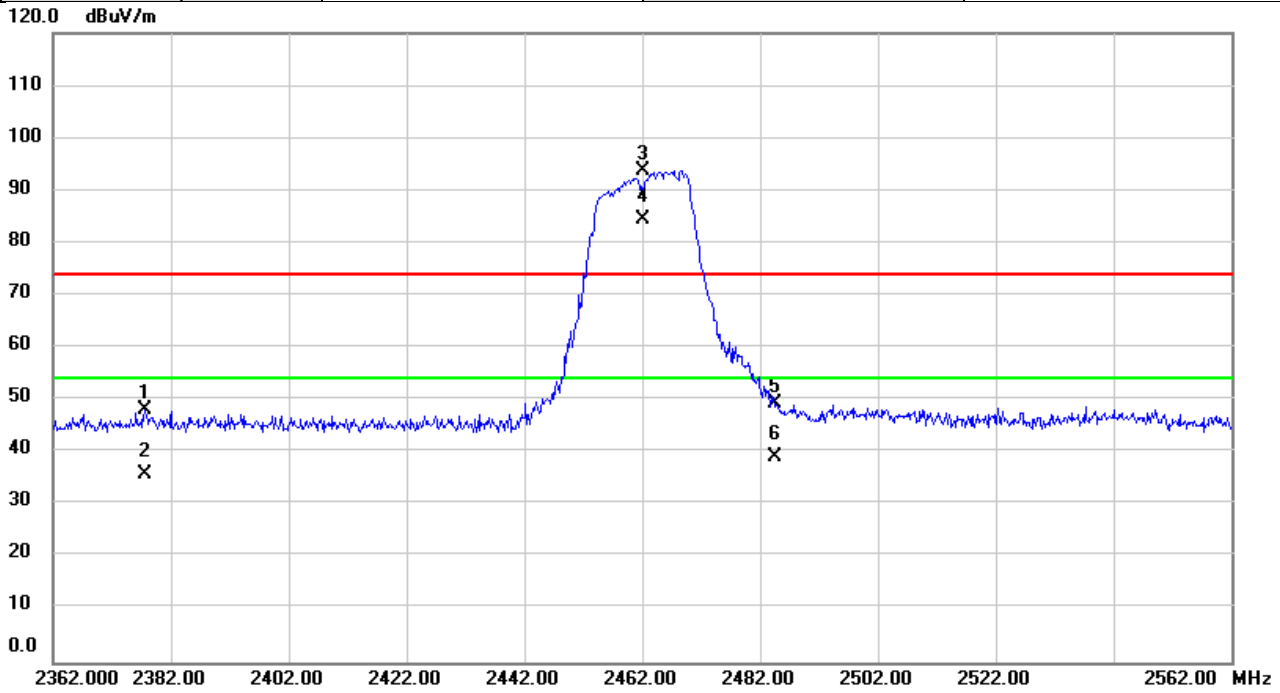

No.	Mk.	Freq.	Reading Level	Correct Factor	Measurement	Limit	Over	Detector	Comment
		MHz	dBuV	dB	dBuV/m	dBuV/m	dB		
1		2377.527	53.90	-5.78	48.12	74.00	-25.88	peak	
2		2377.527	41.50	-5.78	35.72	54.00	-18.28	AVG	
3	X	2462.000	99.57	-5.68	93.89	74.00	19.89	peak	NoLimit
4	*	2462.000	90.04	-5.68	84.36	54.00	30.36	AVG	NoLimit
5		2484.607	54.96	-5.64	49.32	74.00	-24.68	peak	
6		2484.607	44.79	-5.64	39.15	54.00	-14.85	AVG	

REMARKS:

- (1) Measurement Value = Reading Level + Correct Factor.
- (2) Margin Level = Measurement Value - Limit Value.

Test Mode	IEEE 802.11n (HT20)	Test Date	2022/9/6
Test Frequency	2412MHz	Polarization	Vertical
Temp	26°C	Hum.	60%

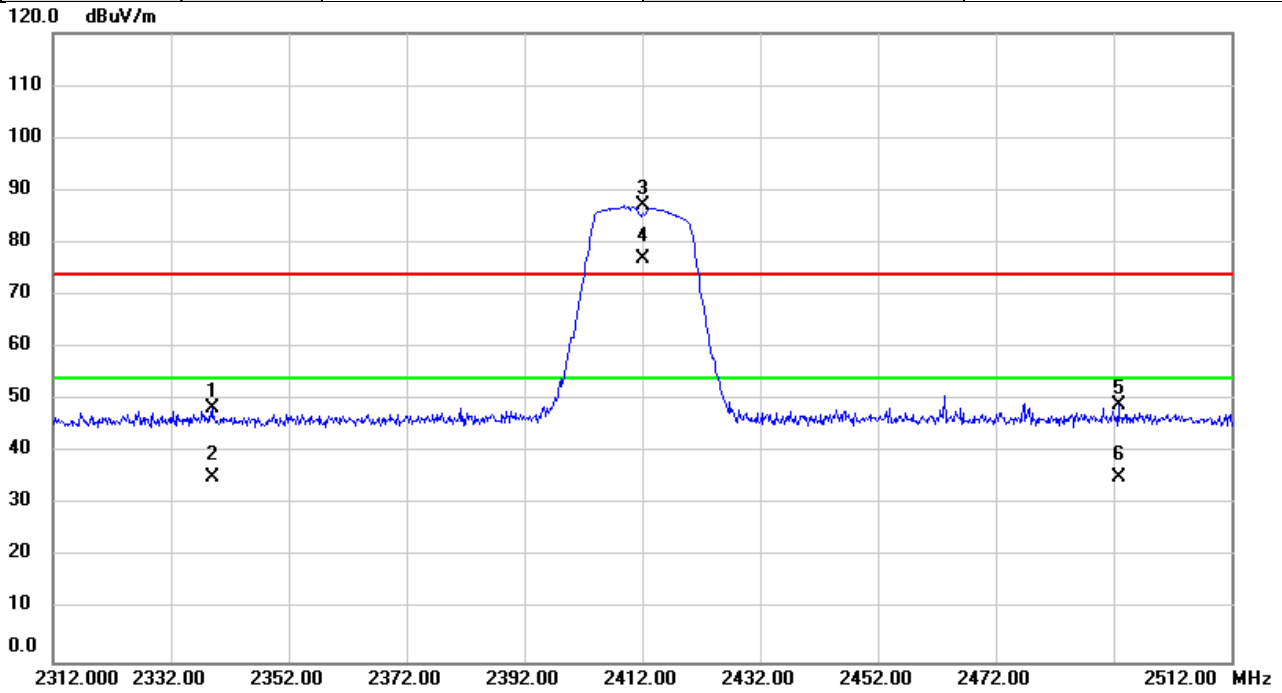

No.	Mk.	Freq.	Reading Level	Correct Factor	Measurement	Limit	Over	Detector	Comment
		MHz	dBuV	dB	dBuV/m	dBuV/m	dB		
1		2338.947	54.17	-5.83	48.34	74.00	-25.66	peak	
2		2338.947	41.10	-5.83	35.27	54.00	-18.73	AVG	
3	X	2412.000	93.04	-5.74	87.30	74.00	13.30	peak	NoLimit
4	*	2412.000	82.76	-5.74	77.02	54.00	23.02	AVG	NoLimit
5		2492.860	54.55	-5.64	48.91	74.00	-25.09	peak	
6		2492.860	40.92	-5.64	35.28	54.00	-18.72	AVG	

REMARKS:

- (1) Measurement Value = Reading Level + Correct Factor.
- (2) Margin Level = Measurement Value - Limit Value.

Test Mode	IEEE 802.11n (HT20)	Test Date	2022/9/6
Test Frequency	2462MHz	Polarization	Vertical
Temp	26°C	Hum.	60%

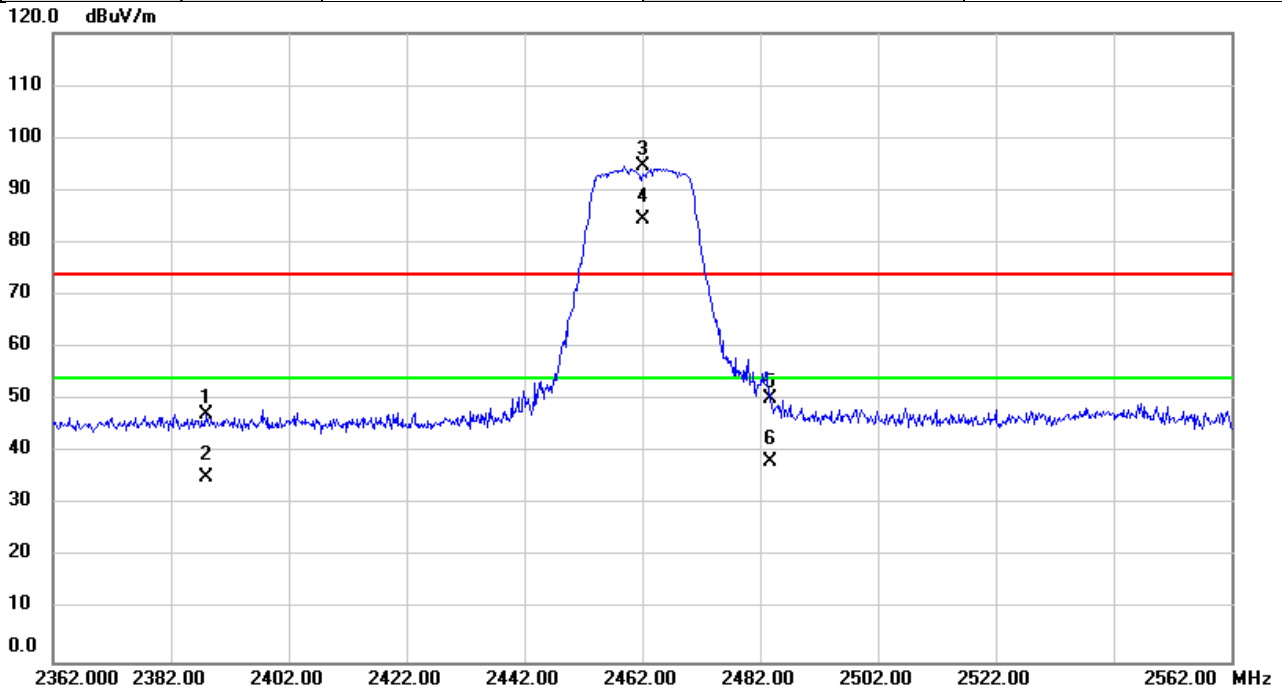

No.	Mk.	Freq.	Reading Level	Correct Factor	Measurement	Limit	Over	Detector	Comment
		MHz	dBuV	dB	dBuV/m	dBuV/m	dB		
1		2387.907	52.91	-5.77	47.14	74.00	-26.86	peak	
2		2387.907	41.00	-5.77	35.23	54.00	-18.77	AVG	
3	X	2462.000	100.19	-5.68	94.51	74.00	20.51	peak	NoLimit
4	*	2462.000	90.26	-5.68	84.58	54.00	30.58	AVG	NoLimit
5		2483.860	55.93	-5.65	50.28	74.00	-23.72	peak	
6		2483.860	44.00	-5.65	38.35	54.00	-15.65	AVG	

REMARKS:

- (1) Measurement Value = Reading Level + Correct Factor.
- (2) Margin Level = Measurement Value - Limit Value.

Test Mode	IEEE 802.11n (HT40)	Test Date	2022/9/6
Test Frequency	2422MHz	Polarization	Vertical
Temp	26°C	Hum.	60%

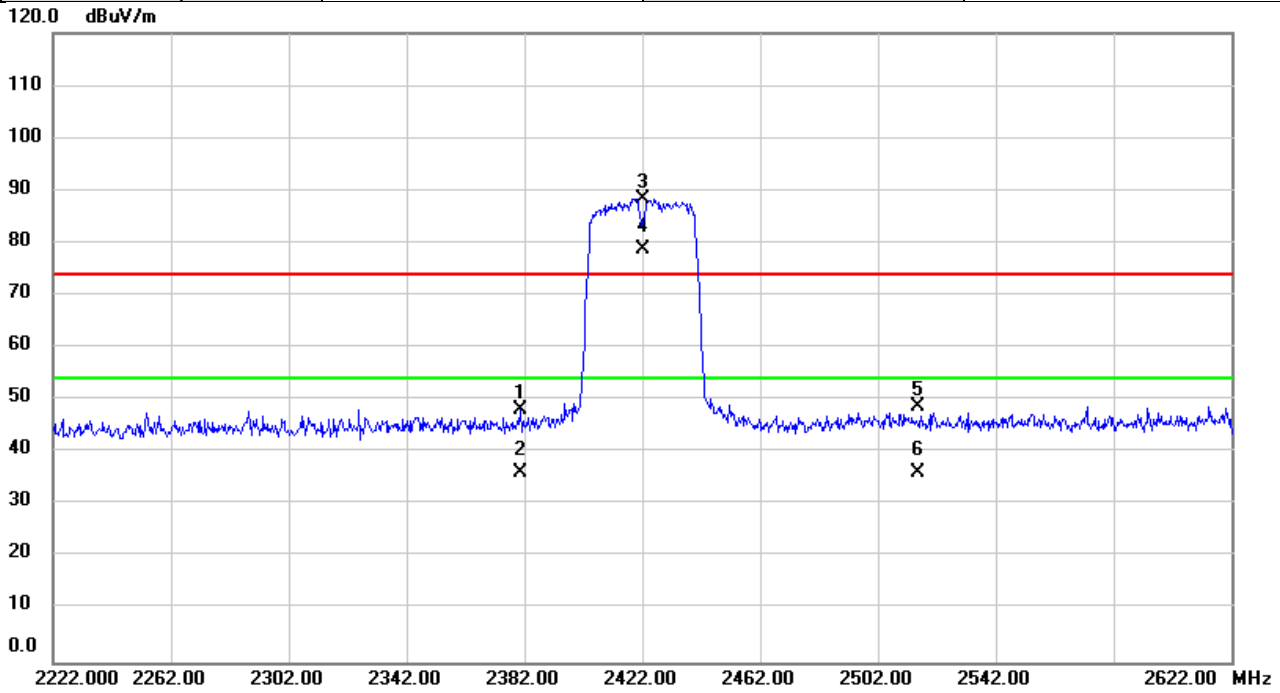

No.	Mk.	Freq.	Reading Level	Correct Factor	Measurement	Limit	Over	Detector	Comment
		MHz	dBuV	dB	dBuV/m	dBuV/m	dB		
1		2380.813	53.92	-5.78	48.14	74.00	-25.86	peak	
2		2380.813	41.94	-5.78	36.16	54.00	-17.84	AVG	
3	X	2422.000	94.10	-5.72	88.38	74.00	14.38	peak	NoLimit
4	*	2422.000	84.60	-5.72	78.88	54.00	24.88	AVG	NoLimit
5		2515.803	54.31	-5.56	48.75	74.00	-25.25	peak	
6		2515.803	41.60	-5.56	36.04	54.00	-17.96	AVG	

REMARKS:

- (1) Measurement Value = Reading Level + Correct Factor.
- (2) Margin Level = Measurement Value - Limit Value.

Test Mode	IEEE 802.11n (HT40)	Test Date	2022/9/6
Test Frequency	2452MHz	Polarization	Vertical
Temp	26°C	Hum.	60%

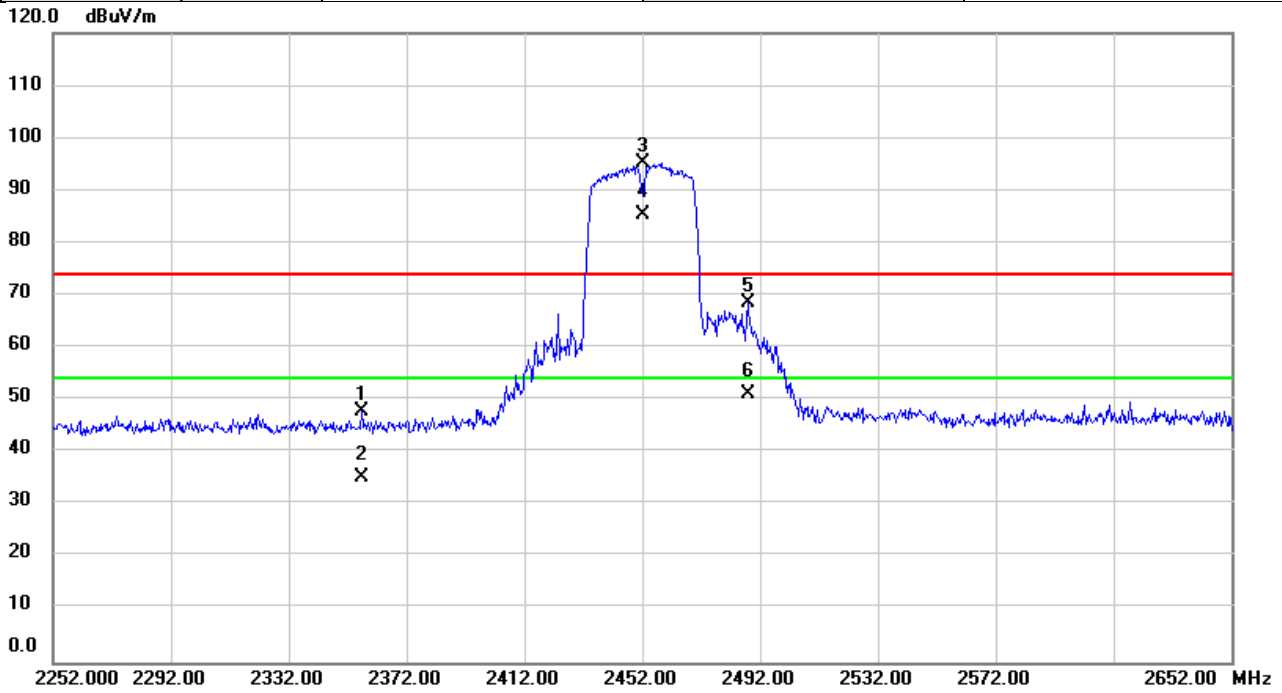

No.	Mk.	Freq.	Reading Level	Correct Factor	Measurement	Limit	Over	Detector	Comment
		MHz	dBuV	dB	dBuV/m	dBuV/m	dB		
1		2356.680	53.71	-5.81	47.90	74.00	-26.10	peak	
2		2356.680	41.11	-5.81	35.30	54.00	-18.70	AVG	
3	X	2452.000	101.06	-5.69	95.37	74.00	21.37	peak	NoLimit
4	*	2452.000	91.00	-5.69	85.31	54.00	31.31	AVG	NoLimit
5		2487.880	74.25	-5.63	68.62	74.00	-5.38	peak	
6		2487.880	56.80	-5.63	51.17	54.00	-2.83	AVG	

REMARKS:

- (1) Measurement Value = Reading Level + Correct Factor.
- (2) Margin Level = Measurement Value - Limit Value.

Test Mode	IEEE 802.11b	Test Date	2022/9/6
Test Frequency	2412MHz	Polarization	Vertical
Temp	26°C	Hum.	60%

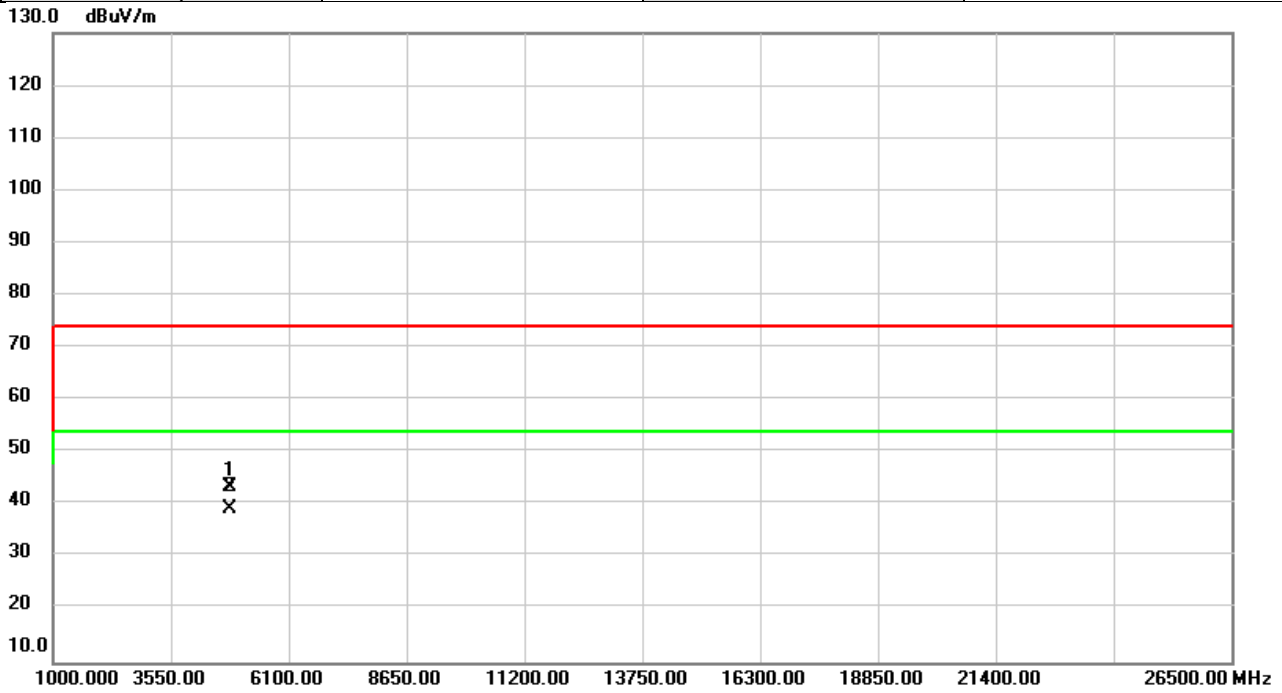

No.	Mk.	Freq.	Reading Level	Correct Factor	Measurement	Limit	Over	Detector	Comment
		MHz	dBuV	dB	dBuV/m	dBuV/m	dB		
1		4824.000	42.59	0.72	43.31	74.00	-30.69	peak	
2	*	4824.000	38.46	0.72	39.18	54.00	-14.82	AVG	

REMARKS:

- (1) Measurement Value = Reading Level + Correct Factor.
- (2) Margin Level = Measurement Value - Limit Value.

Test Mode	IEEE 802.11b	Test Date	2022/9/6
Test Frequency	2412MHz	Polarization	Horizontal
Temp	26°C	Hum.	60%

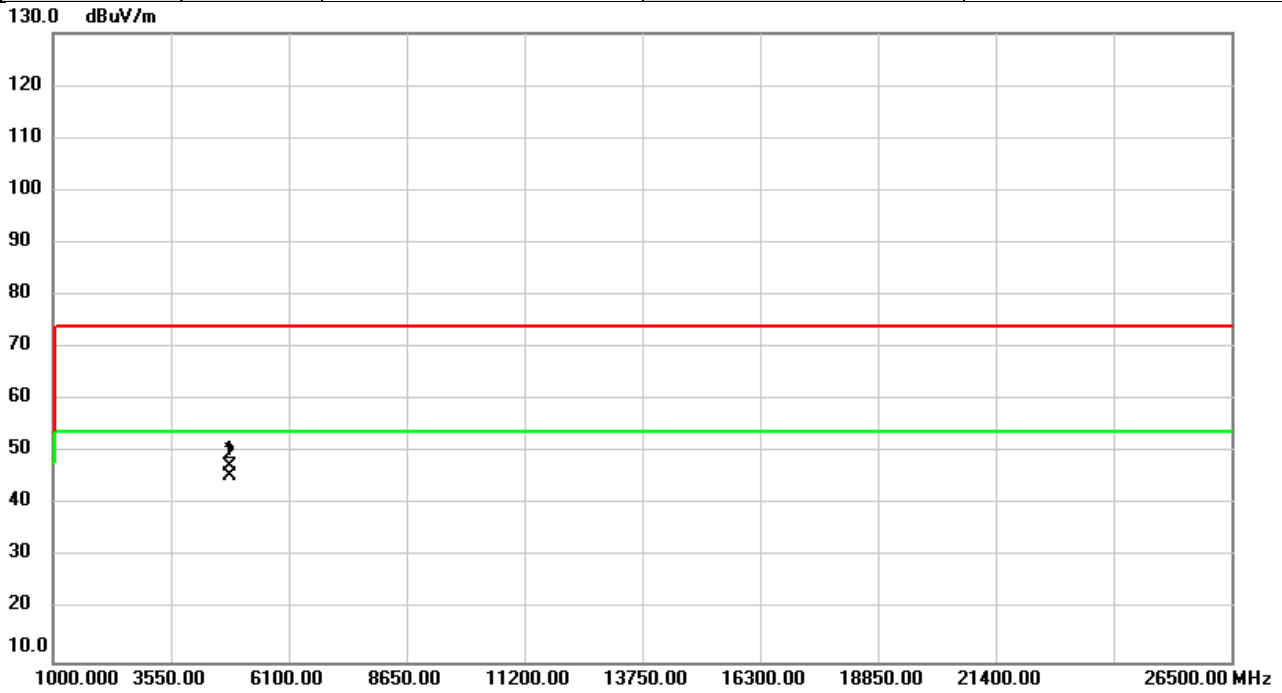

No.	Mk.	Freq.	Reading Level	Correct Factor	Measurement	Limit	Over	Detector	Comment
		MHz	dBuV	dB	dBuV/m	dBuV/m	dB		
1		4824.000	46.48	0.72	47.20	74.00	-26.80	peak	
2	*	4824.000	44.74	0.72	45.46	54.00	-8.54	AVG	

REMARKS:

- (1) Measurement Value = Reading Level + Correct Factor.
- (2) Margin Level = Measurement Value - Limit Value.

Test Mode	IEEE 802.11b	Test Date	2022/9/7
Test Frequency	2437MHz	Polarization	Vertical
Temp	26°C	Hum.	60%

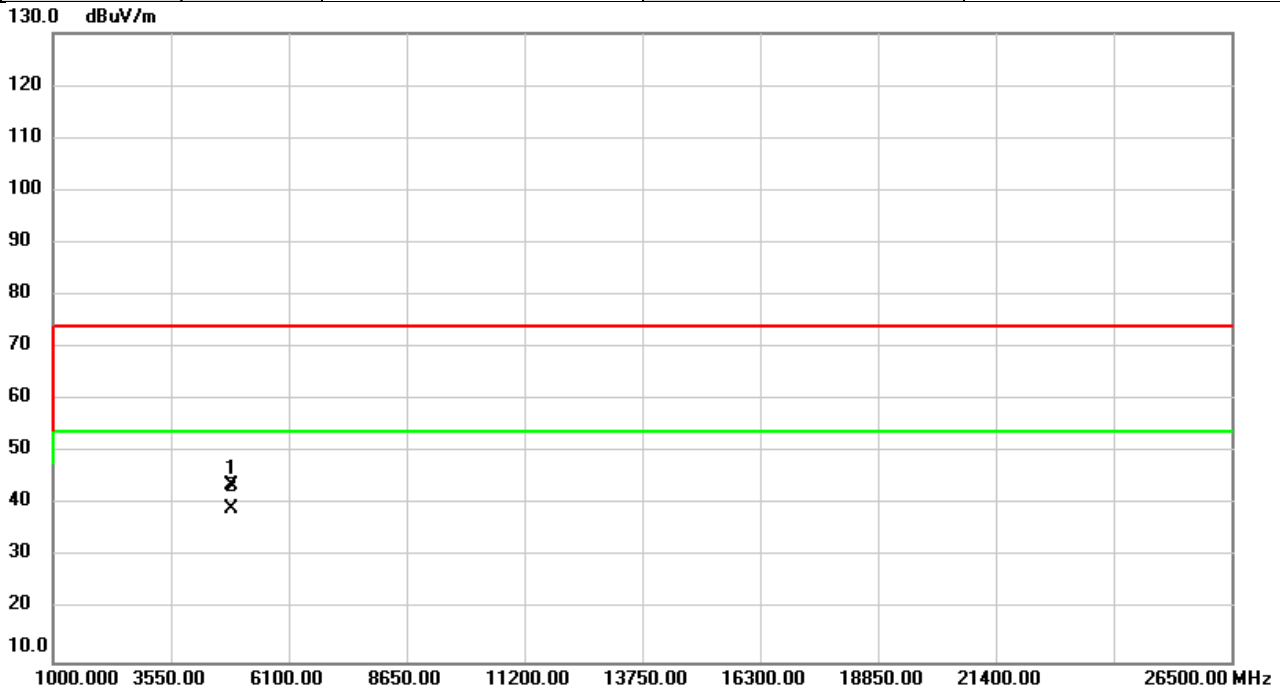

No.	Mk.	Freq.	Reading Level	Correct Factor	Measurement	Limit	Over	Detector	Comment
		MHz	dBuV	dB	dBuV/m	dBuV/m	dB		
1		4874.000	42.75	0.89	43.64	74.00	-30.36	peak	
2	*	4874.000	38.27	0.89	39.16	54.00	-14.84	AVG	

REMARKS:

- (1) Measurement Value = Reading Level + Correct Factor.
- (2) Margin Level = Measurement Value - Limit Value.

Test Mode	IEEE 802.11b	Test Date	2022/9/7
Test Frequency	2437MHz	Polarization	Horizontal
Temp	26°C	Hum.	60%

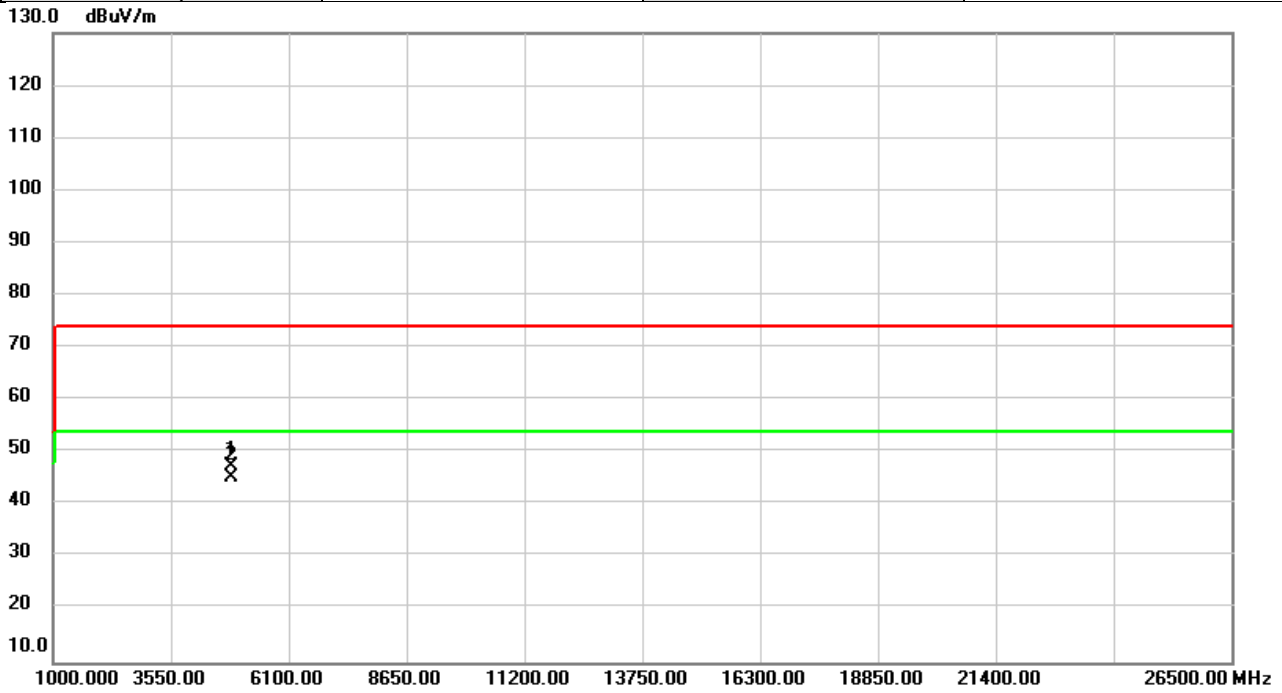

No.	Mk.	Freq. MHz	Reading Level dBuV	Correct Factor dB	Measure- ment dBuV/m	Limit dBuV/m	Over dB	Detector	Comment
1		4874.000	46.35	0.89	47.24	74.00	-26.76	peak	
2	*	4874.000	44.22	0.89	45.11	54.00	-8.89	AVG	

REMARKS:

- (1) Measurement Value = Reading Level + Correct Factor.
- (2) Margin Level = Measurement Value - Limit Value.

Test Mode	IEEE 802.11b	Test Date	2022/9/7
Test Frequency	2462MHz	Polarization	Vertical
Temp	26°C	Hum.	60%

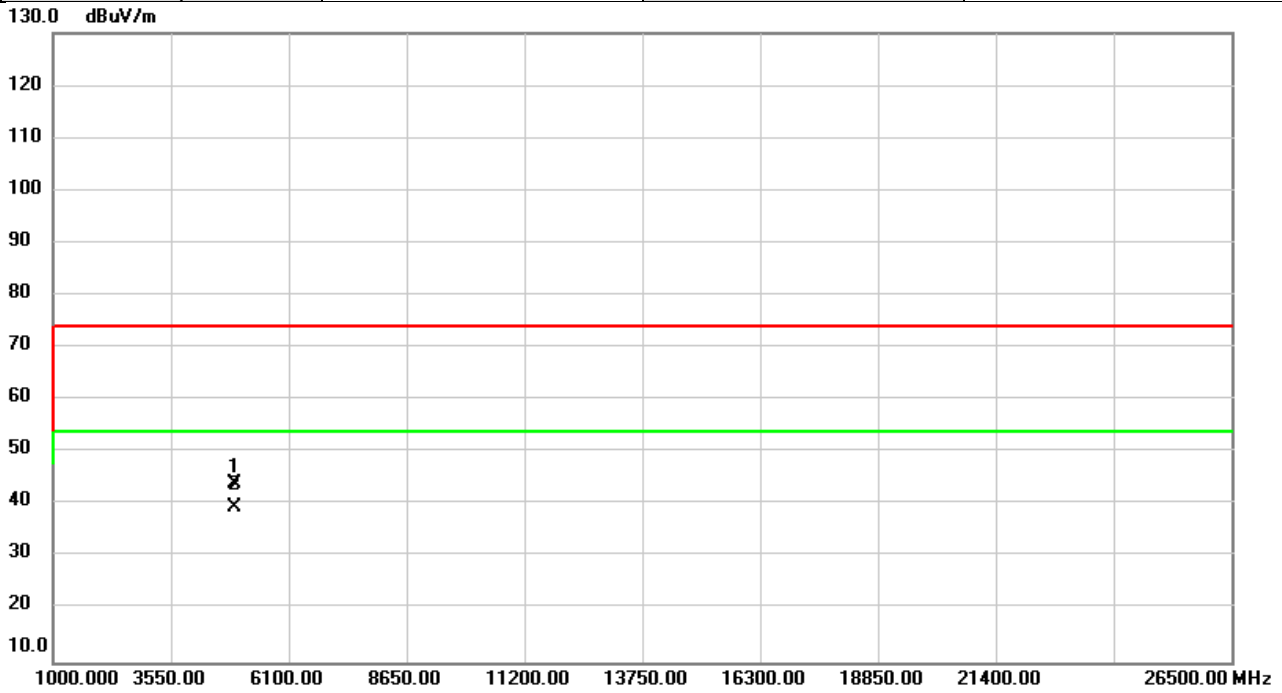

No.	Mk.	Freq. MHz	Reading Level dBuV	Correct Factor dB	Measure- ment dBuV/m	Limit dBuV/m	Over dB	Detector	Comment
1		4924.000	42.84	1.07	43.91	74.00	-30.09	peak	
2	*	4924.000	38.34	1.07	39.41	54.00	-14.59	AVG	

REMARKS:

- (1) Measurement Value = Reading Level + Correct Factor.
- (2) Margin Level = Measurement Value - Limit Value.

Test Mode	IEEE 802.11b	Test Date	2022/9/7
Test Frequency	2462MHz	Polarization	Horizontal
Temp	26°C	Hum.	60%

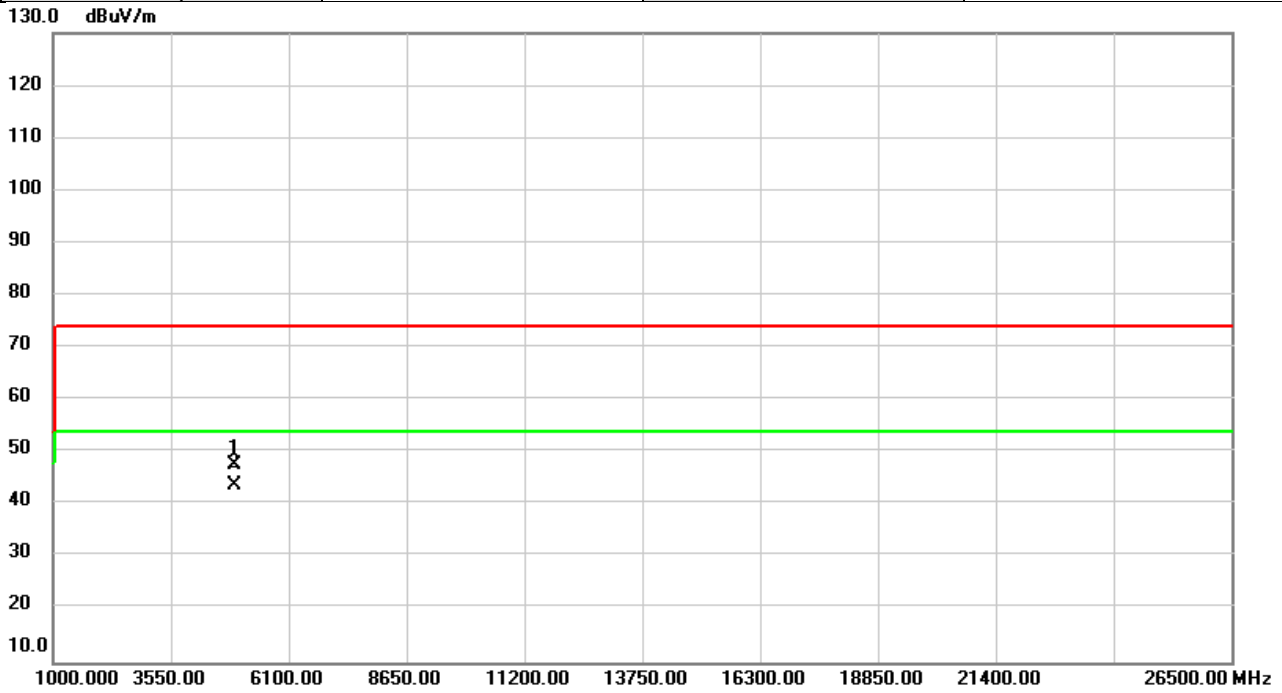

No.	Mk.	Freq. MHz	Reading Level dBuV	Correct Factor dB	Measure- ment dBuV/m	Limit dBuV/m	Over dB	Detector	Comment
1		4924.000	46.69	1.07	47.76	74.00	-26.24	peak	
2	*	4924.000	42.82	1.07	43.89	54.00	-10.11	AVG	

REMARKS:

- (1) Measurement Value = Reading Level + Correct Factor.
- (2) Margin Level = Measurement Value - Limit Value.

Test Mode	IEEE 802.11g	Test Date	2022/9/7
Test Frequency	2412MHz	Polarization	Vertical
Temp	26°C	Hum.	60%

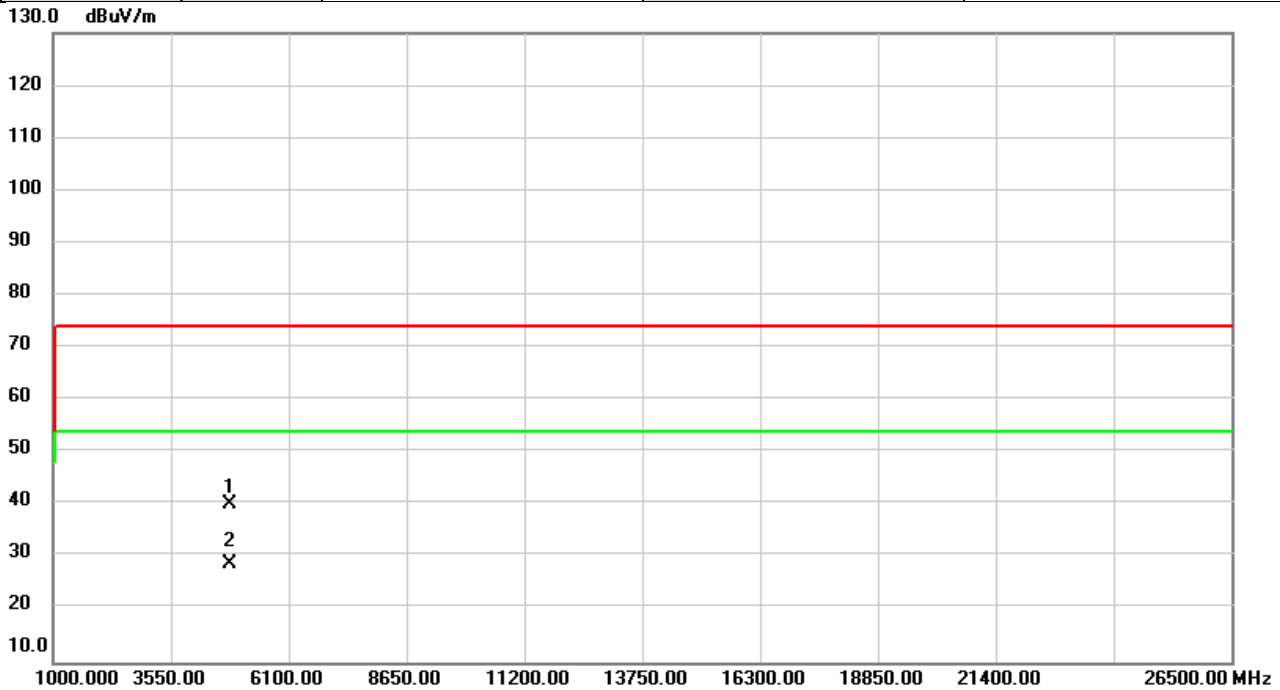

No.	Mk.	Freq. MHz	Reading Level dBuV	Correct Factor dB	Measure- ment dBuV/m	Limit dBuV/m	Over dB	Detector	Comment
1		4824.000	39.58	0.72	40.30	74.00	-33.70	peak	
2	*	4824.000	28.10	0.72	28.82	54.00	-25.18	AVG	

REMARKS:

- (1) Measurement Value = Reading Level + Correct Factor.
- (2) Margin Level = Measurement Value - Limit Value.

Test Mode	IEEE 802.11g	Test Date	2022/9/7
Test Frequency	2412MHz	Polarization	Horizontal
Temp	26°C	Hum.	60%

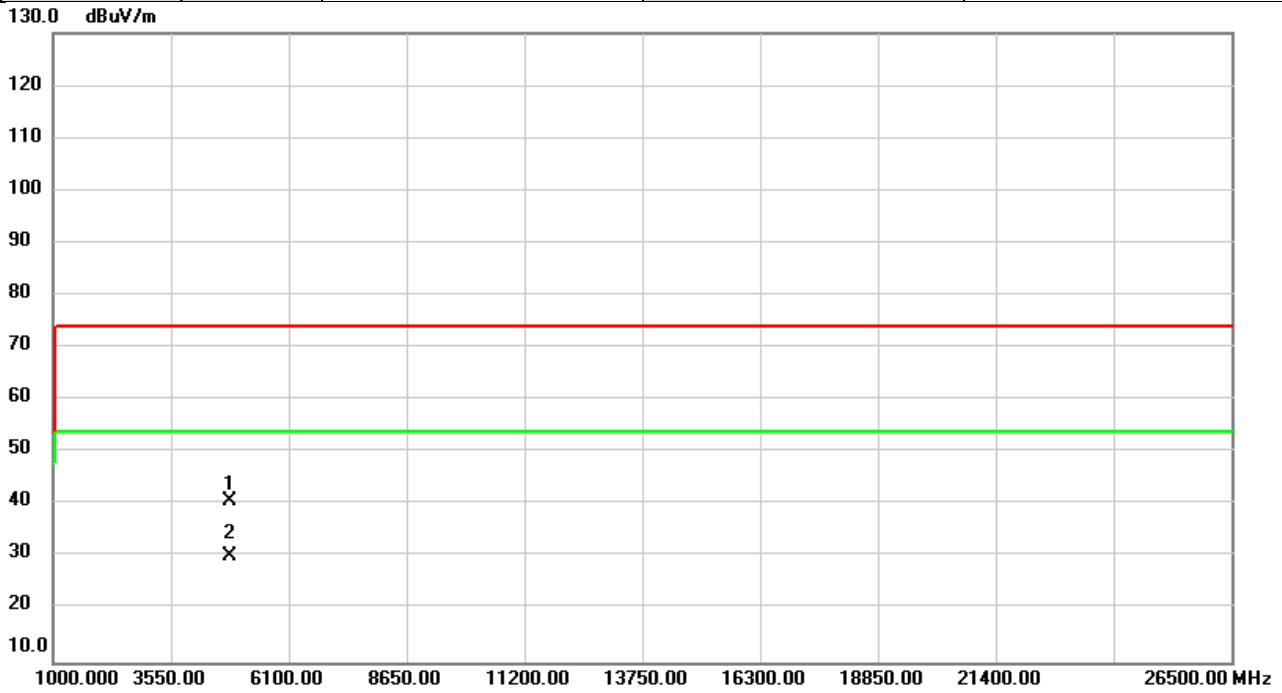

No.	Mk.	Freq. MHz	Reading Level dBuV	Correct Factor dB	Measure- ment dBuV/m	Limit dBuV/m	Over dB	Detector	Comment
1		4824.000	40.09	0.72	40.81	74.00	-33.19	peak	
2	*	4824.000	29.59	0.72	30.31	54.00	-23.69	AVG	

REMARKS:

- (1) Measurement Value = Reading Level + Correct Factor.
- (2) Margin Level = Measurement Value - Limit Value.

Test Mode	IEEE 802.11g	Test Date	2022/9/7
Test Frequency	2437MHz	Polarization	Vertical
Temp	26°C	Hum.	60%

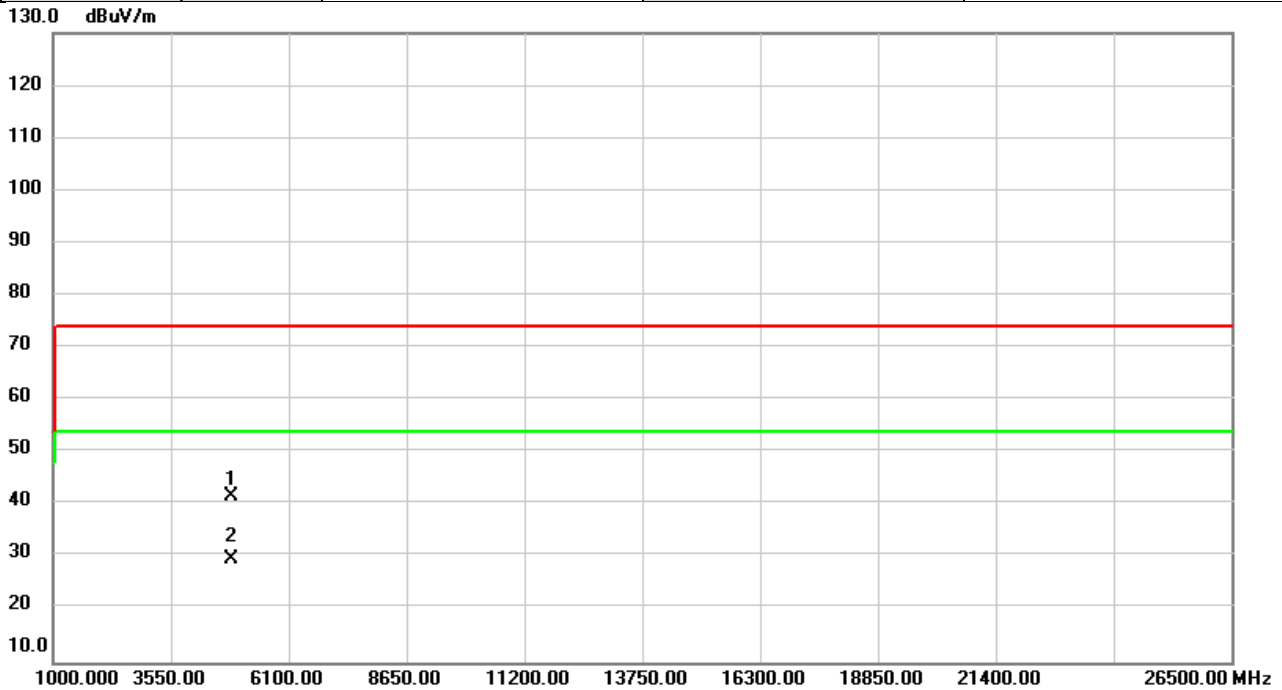

No.	Mk.	Freq. MHz	Reading Level dBuV	Correct Factor dB	Measure- ment dBuV/m	Limit dBuV/m	Over dB	Detector	Comment
1		4874.000	40.71	0.89	41.60	74.00	-32.40	peak	
2	*	4874.000	28.70	0.89	29.59	54.00	-24.41	AVG	

REMARKS:

- (1) Measurement Value = Reading Level + Correct Factor.
- (2) Margin Level = Measurement Value - Limit Value.

Test Mode	IEEE 802.11g	Test Date	2022/9/7
Test Frequency	2437MHz	Polarization	Horizontal
Temp	26°C	Hum.	60%

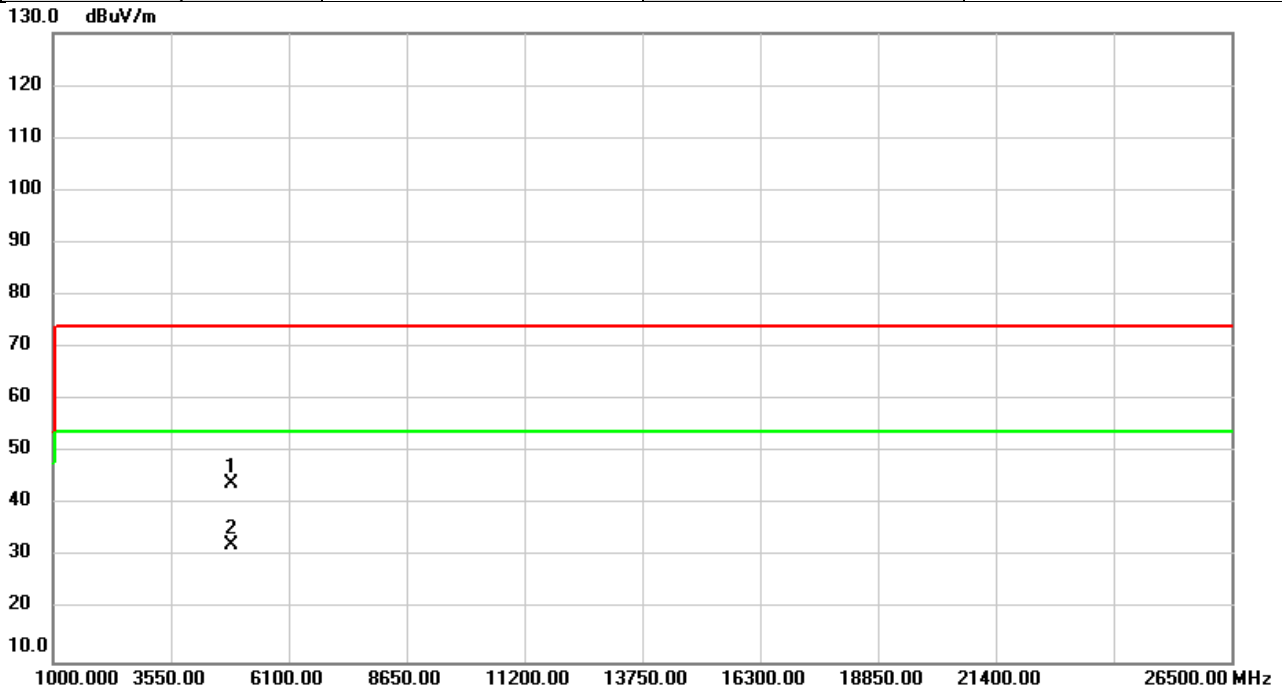

No.	Mk.	Freq. MHz	Reading Level dBuV	Correct Factor dB	Measure- ment dBuV/m	Limit dBuV/m	Over dB	Detector	Comment
1	*	4874.000	43.23	0.89	44.12	74.00	-29.88	peak	
2		4874.000	31.46	0.89	32.35	74.00	-41.65	peak	

REMARKS:

- (1) Measurement Value = Reading Level + Correct Factor.
- (2) Margin Level = Measurement Value - Limit Value.

Test Mode	IEEE 802.11g	Test Date	2022/9/7
Test Frequency	2462MHz	Polarization	Vertical
Temp	26°C	Hum.	60%

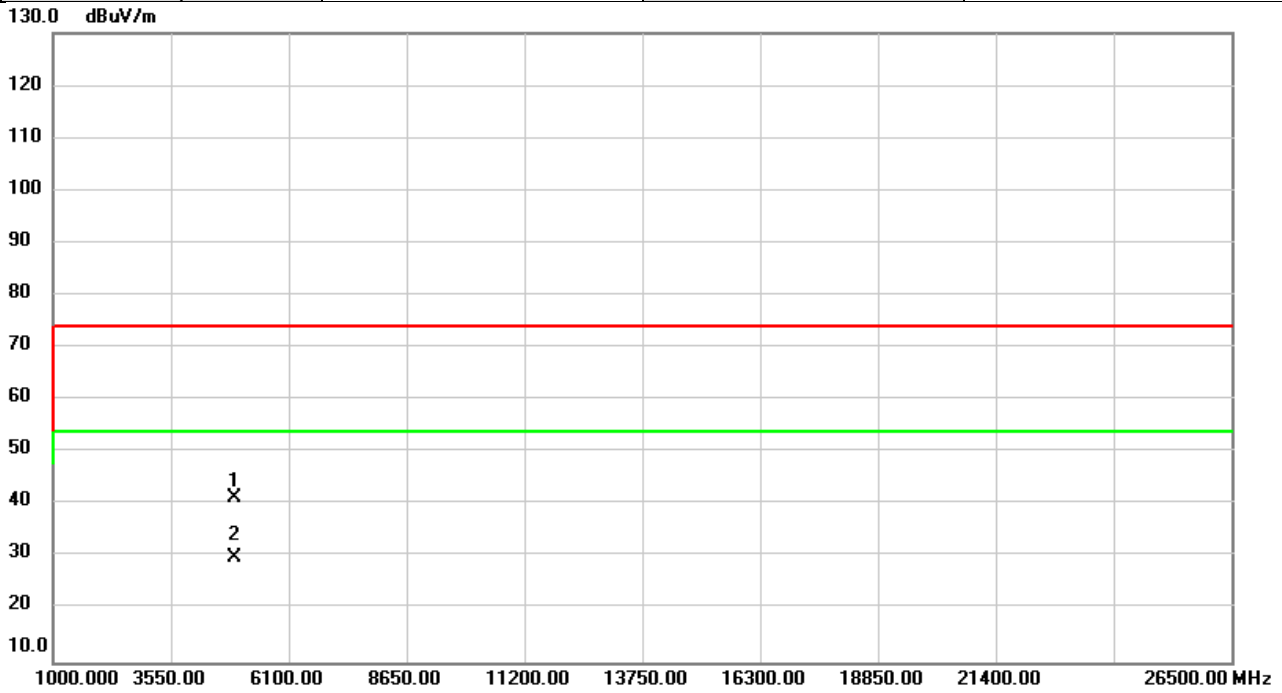

No.	Mk.	Freq. MHz	Reading Level dBuV	Correct Factor dB	Measure- ment dBuV/m	Limit dBuV/m	Over dB	Detector	Comment
1		4924.000	40.42	1.07	41.49	74.00	-32.51	peak	
2	*	4924.000	28.74	1.07	29.81	54.00	-24.19	AVG	

REMARKS:

- (1) Measurement Value = Reading Level + Correct Factor.
- (2) Margin Level = Measurement Value - Limit Value.

Test Mode	IEEE 802.11g	Test Date	2022/9/7
Test Frequency	2462MHz	Polarization	Horizontal
Temp	26°C	Hum.	60%

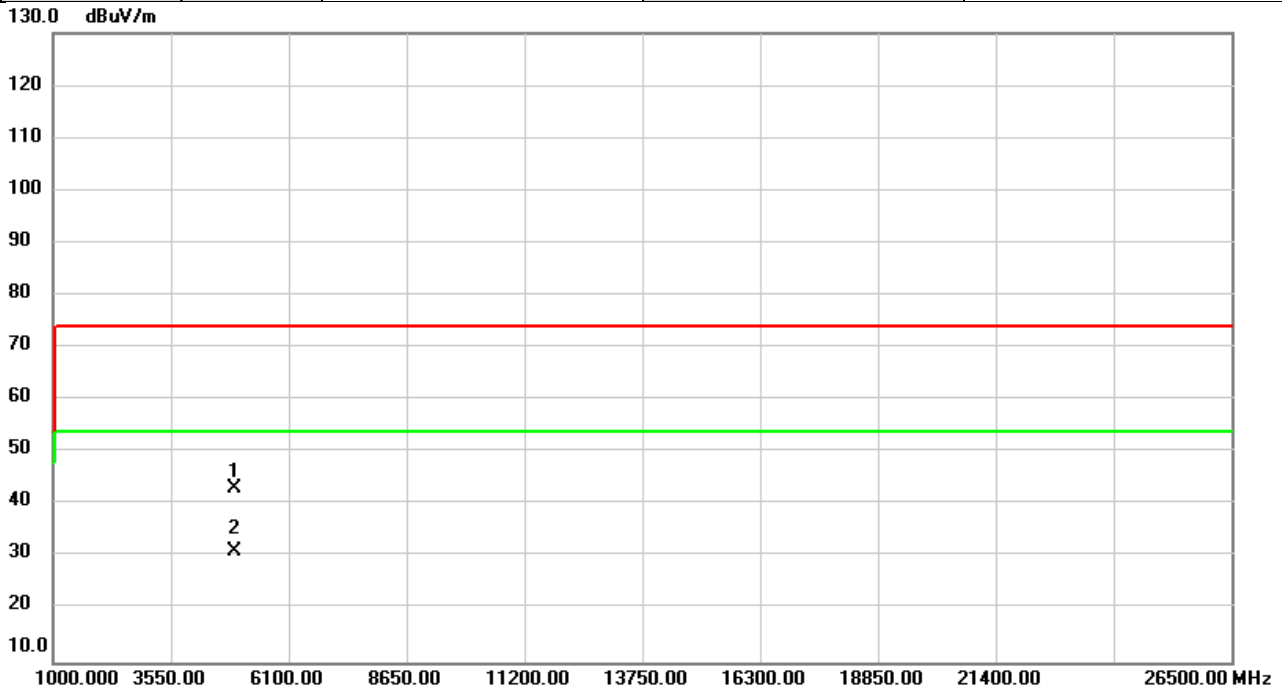

No.	Mk.	Freq. MHz	Reading Level dBuV	Correct Factor dB	Measure- ment dBuV/m	Limit dBuV/m	Over dB	Detector	Comment
1		4924.000	42.11	1.07	43.18	74.00	-30.82	peak	
2	*	4924.000	30.21	1.07	31.28	54.00	-22.72	AVG	

REMARKS:

- (1) Measurement Value = Reading Level + Correct Factor.
- (2) Margin Level = Measurement Value - Limit Value.

Test Mode	IEEE 802.11n (HT20)	Test Date	2022/9/7
Test Frequency	2412MHz	Polarization	Vertical
Temp	26°C	Hum.	60%

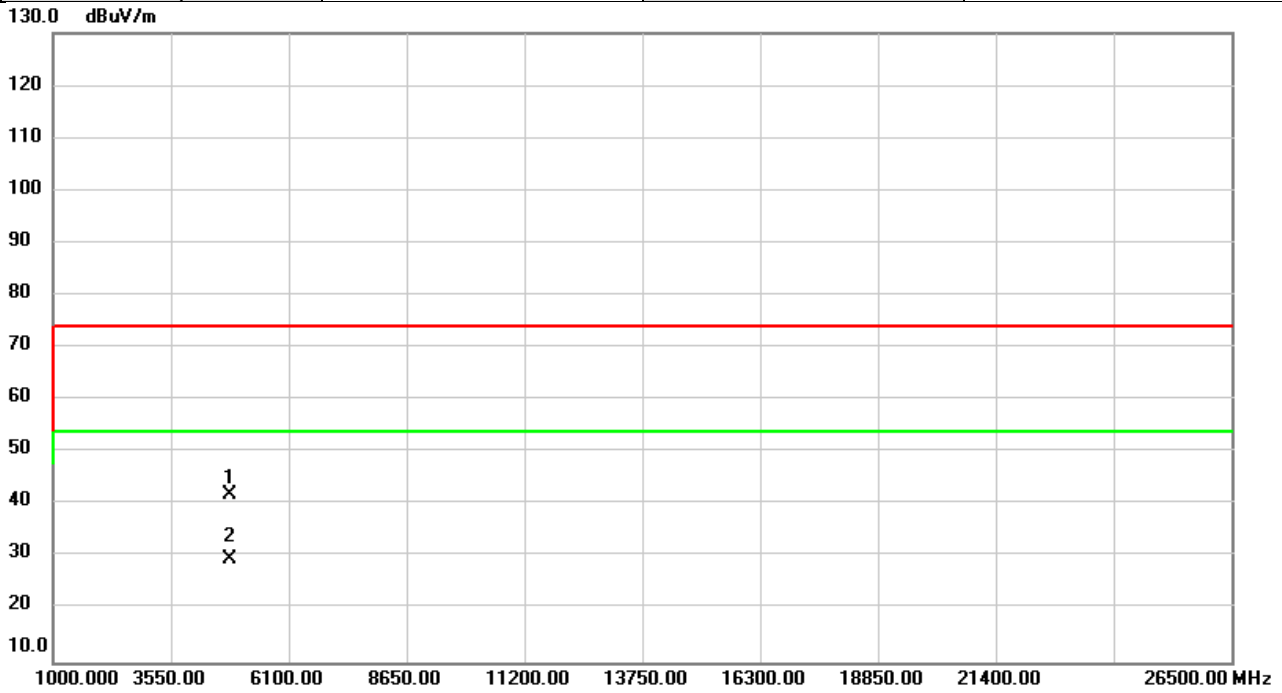

No.	Mk.	Freq. MHz	Reading Level dBuV	Correct Factor dB	Measure- ment dBuV/m	Limit dBuV/m	Over dB	Detector	Comment
1		4824.000	41.09	0.72	41.81	74.00	-32.19	peak	
2	*	4824.000	28.92	0.72	29.64	54.00	-24.36	AVG	

REMARKS:

- (1) Measurement Value = Reading Level + Correct Factor.
- (2) Margin Level = Measurement Value - Limit Value.

Test Mode	IEEE 802.11n (HT20)	Test Date	2022/9/7
Test Frequency	2412MHz	Polarization	Horizontal
Temp	26°C	Hum.	60%

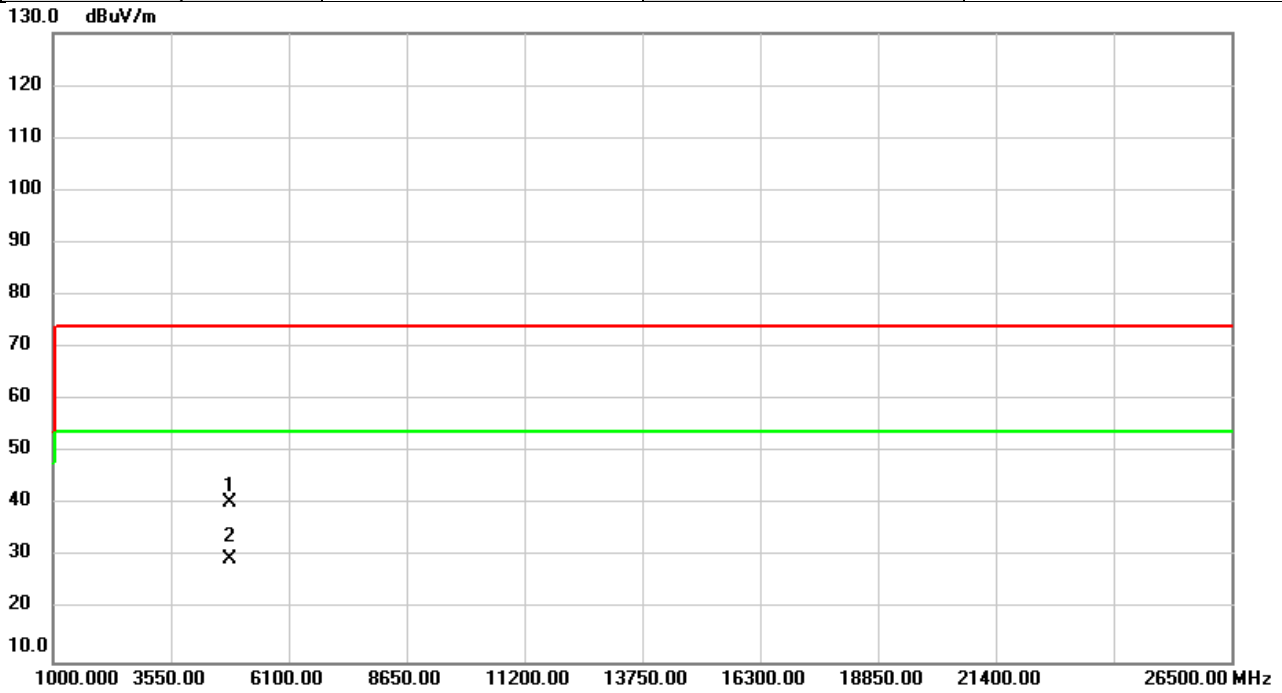

No.	Mk.	Freq. MHz	Reading Level dBuV	Correct Factor dB	Measure- ment dBuV/m	Limit dBuV/m	Over dB	Detector	Comment
1		4824.000	39.66	0.72	40.38	74.00	-33.62	peak	
2	*	4824.000	28.98	0.72	29.70	54.00	-24.30	AVG	

REMARKS:

- (1) Measurement Value = Reading Level + Correct Factor.
- (2) Margin Level = Measurement Value - Limit Value.

Test Mode	IEEE 802.11n (HT20)	Test Date	2022/9/7
Test Frequency	2437MHz	Polarization	Vertical
Temp	26°C	Hum.	60%

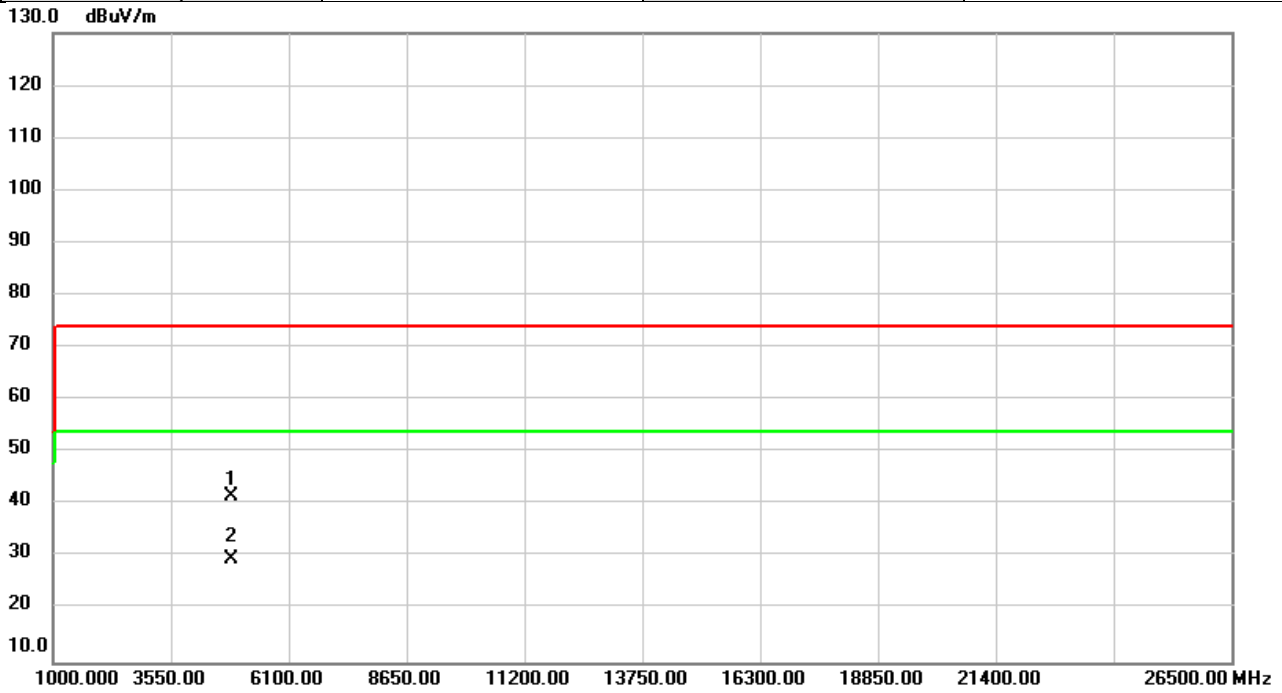

No.	Mk.	Freq. MHz	Reading Level dBuV	Correct Factor dB	Measure- ment dBuV/m	Limit dBuV/m	Over dB	Detector	Comment
1		4874.000	40.64	0.89	41.53	74.00	-32.47	peak	
2	*	4874.000	28.66	0.89	29.55	54.00	-24.45	AVG	

REMARKS:

- (1) Measurement Value = Reading Level + Correct Factor.
- (2) Margin Level = Measurement Value - Limit Value.

Test Mode	IEEE 802.11n (HT20)	Test Date	2022/9/7
Test Frequency	2437MHz	Polarization	Horizontal
Temp	26°C	Hum.	60%

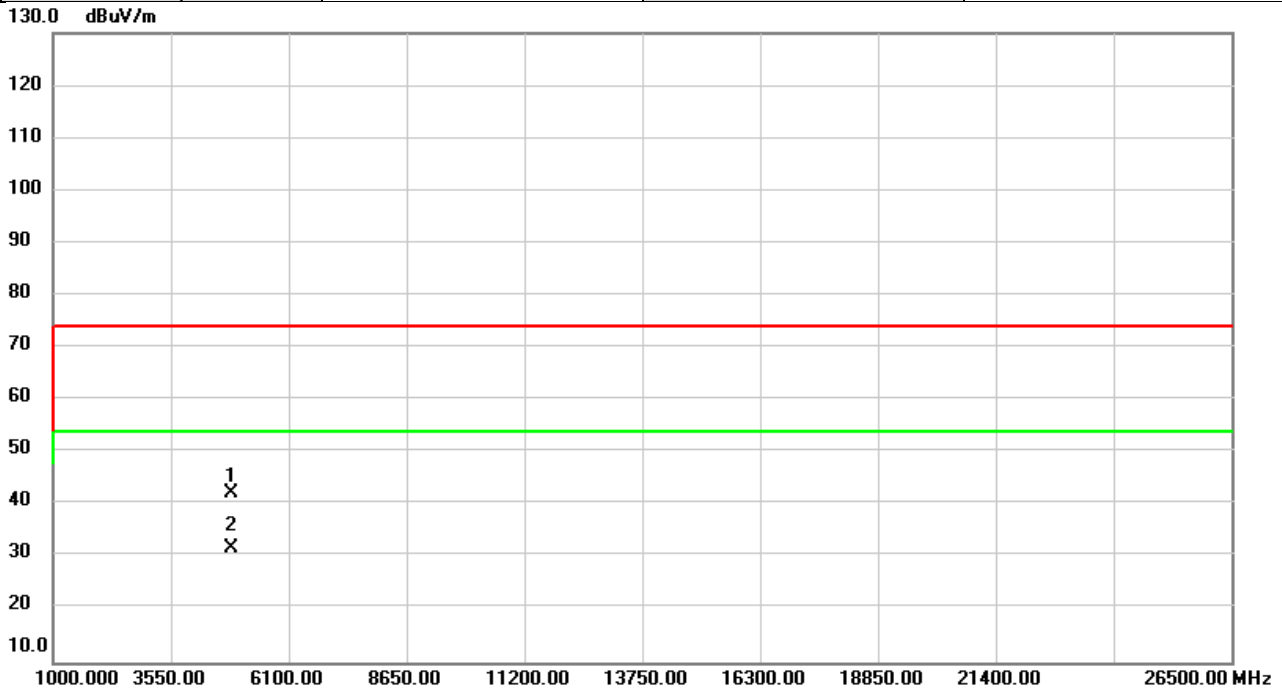

No.	Mk.	Freq. MHz	Reading Level dBuV	Correct Factor dB	Measure- ment dBuV/m	Limit dBuV/m	Over dB	Detector	Comment
1		4874.000	41.27	0.89	42.16	74.00	-31.84	peak	
2	*	4874.000	30.94	0.89	31.83	54.00	-22.17	AVG	

REMARKS:

- (1) Measurement Value = Reading Level + Correct Factor.
- (2) Margin Level = Measurement Value - Limit Value.

Test Mode	IEEE 802.11n (HT20)	Test Date	2022/9/7
Test Frequency	2462MHz	Polarization	Vertical
Temp	26°C	Hum.	60%

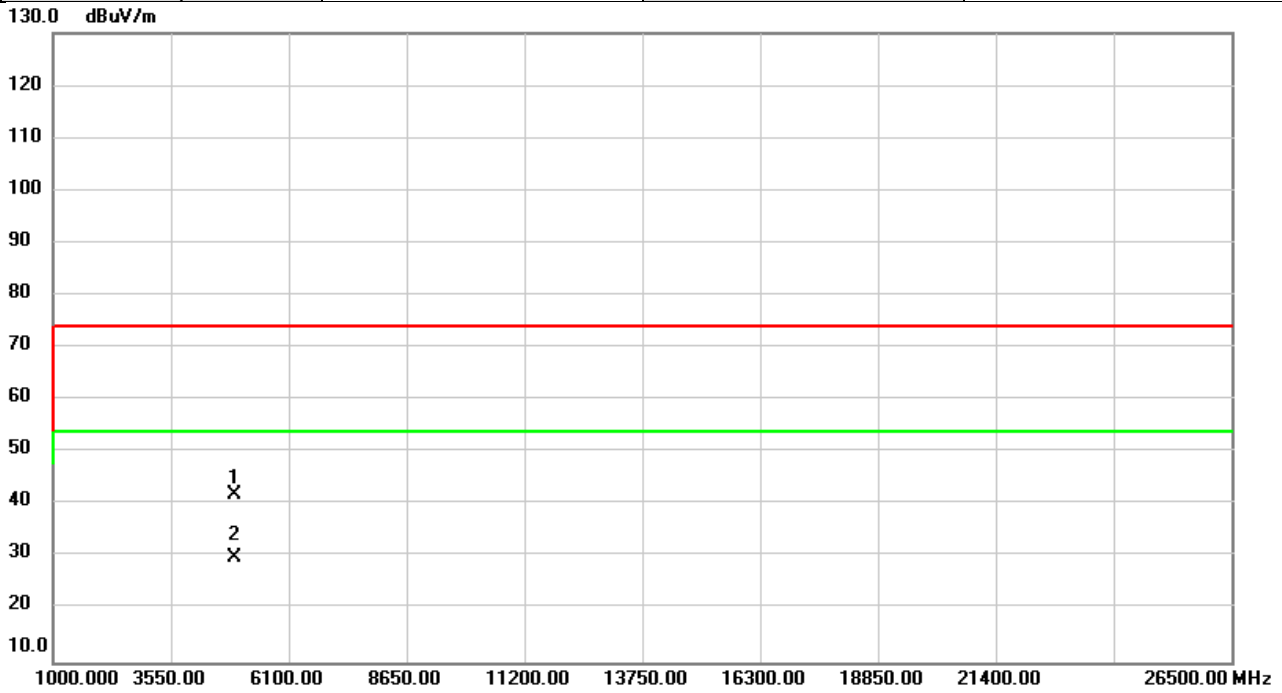

No.	Mk.	Freq. MHz	Reading Level dBuV	Correct Factor dB	Measure- ment dBuV/m	Limit dBuV/m	Over dB	Detector	Comment
1		4924.000	40.91	1.07	41.98	74.00	-32.02	peak	
2	*	4924.000	28.74	1.07	29.81	54.00	-24.19	AVG	

REMARKS:

- (1) Measurement Value = Reading Level + Correct Factor.
- (2) Margin Level = Measurement Value - Limit Value.

Test Mode	IEEE 802.11n (HT20)	Test Date	2022/9/7
Test Frequency	2462MHz	Polarization	Horizontal
Temp	26°C	Hum.	60%

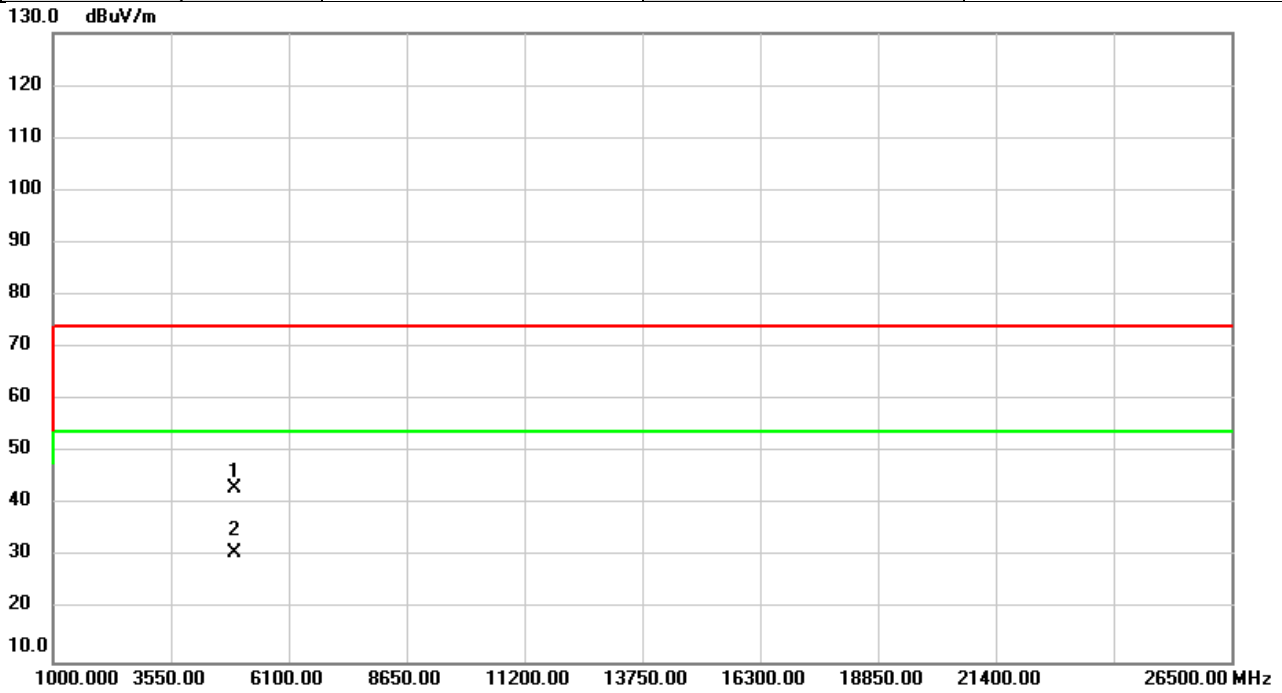

No.	Mk.	Freq. MHz	Reading Level dBuV	Correct Factor dB	Measure- ment dBuV/m	Limit dBuV/m	Over dB	Detector	Comment
1		4924.000	42.18	1.07	43.25	74.00	-30.75	peak	
2	*	4924.000	29.84	1.07	30.91	54.00	-23.09	AVG	

REMARKS:

- (1) Measurement Value = Reading Level + Correct Factor.
- (2) Margin Level = Measurement Value - Limit Value.

Test Mode	IEEE 802.11n (HT40)	Test Date	2022/9/7
Test Frequency	2422MHz	Polarization	Vertical
Temp	26°C	Hum.	60%

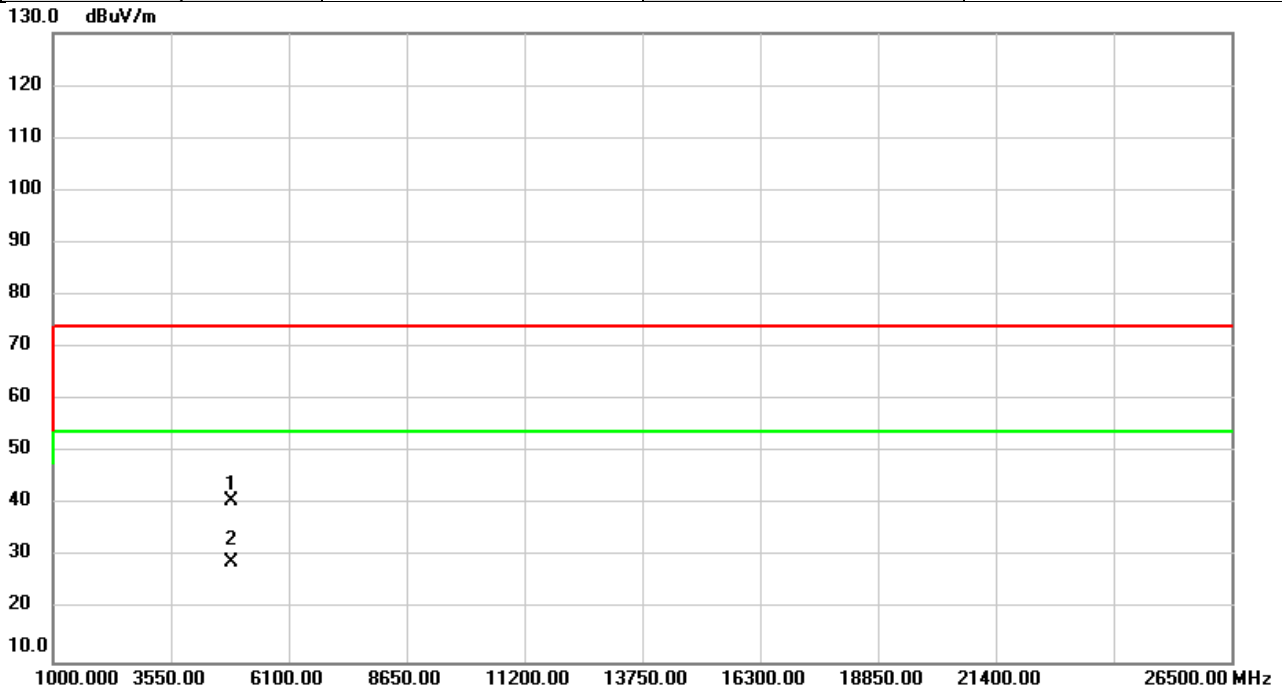

No.	Mk.	Freq. MHz	Reading Level dBuV	Correct Factor dB	Measure- ment dBuV/m	Limit dBuV/m	Over dB	Detector	Comment
1		4844.000	39.91	0.78	40.69	74.00	-33.31	peak	
2	*	4844.000	28.15	0.78	28.93	54.00	-25.07	AVG	

REMARKS:

- (1) Measurement Value = Reading Level + Correct Factor.
- (2) Margin Level = Measurement Value - Limit Value.

Test Mode	IEEE 802.11n (HT40)	Test Date	2022/9/7
Test Frequency	2422MHz	Polarization	Horizontal
Temp	26°C	Hum.	60%

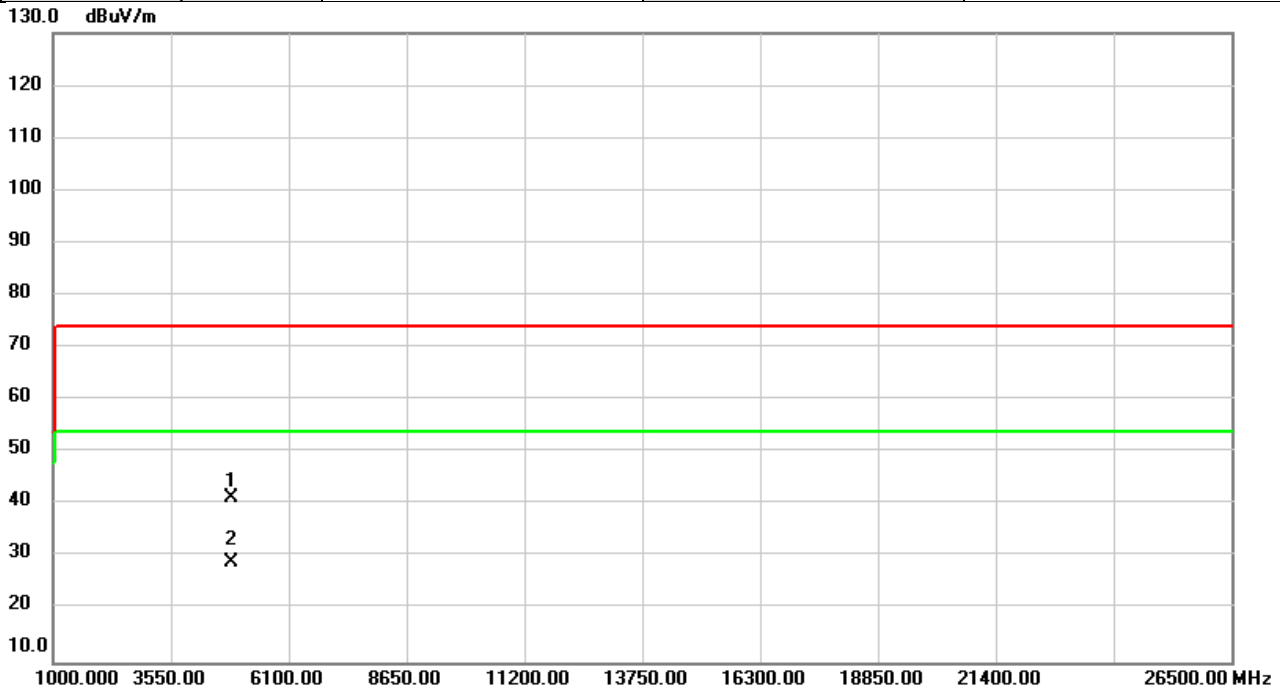

No.	Mk.	Freq. MHz	Reading Level dBuV	Correct Factor dB	Measure- ment dBuV/m	Limit dBuV/m	Over dB	Detector	Comment
1		4844.000	40.58	0.78	41.36	74.00	-32.64	peak	
2	*	4844.000	28.19	0.78	28.97	54.00	-25.03	AVG	

REMARKS:

- (1) Measurement Value = Reading Level + Correct Factor.
- (2) Margin Level = Measurement Value - Limit Value.

Test Mode	IEEE 802.11n (HT40)	Test Date	2022/9/7
Test Frequency	2437MHz	Polarization	Vertical
Temp	26°C	Hum.	60%

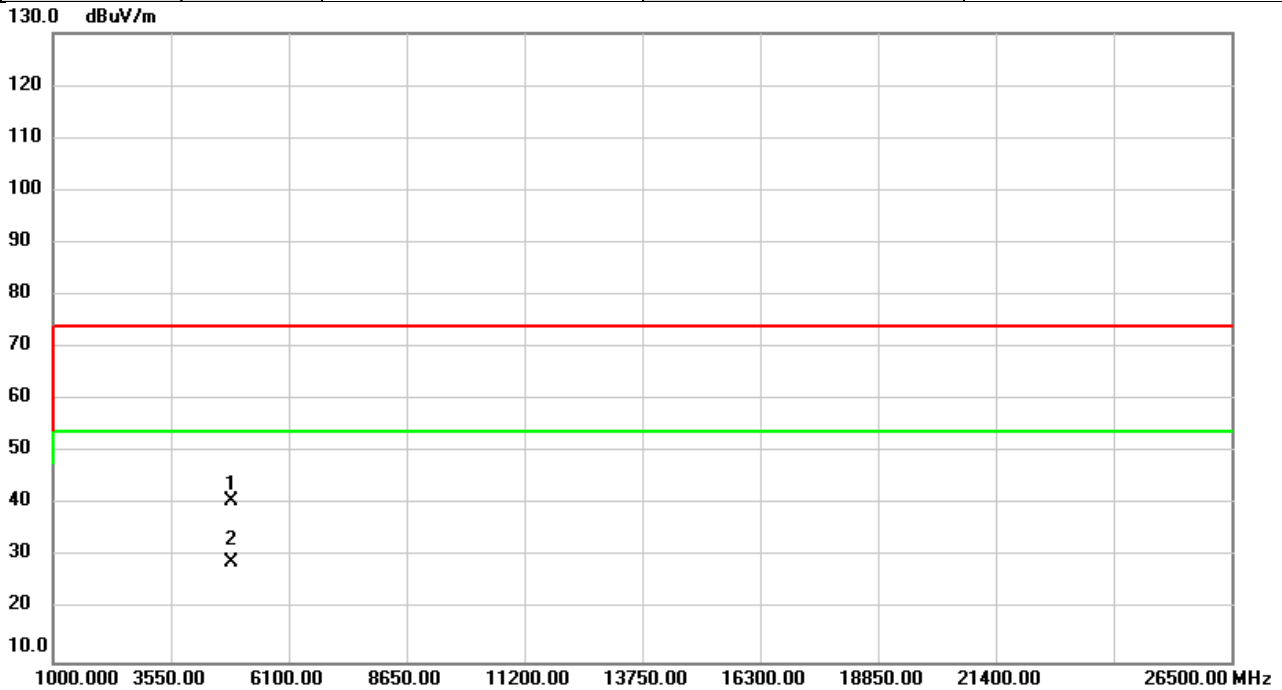

No.	Mk.	Freq. MHz	Reading Level dBuV	Correct Factor dB	Measure- ment dBuV/m	Limit dBuV/m	Over dB	Detector	Comment
1		4874.000	39.85	0.89	40.74	74.00	-33.26	peak	
2	*	4874.000	28.30	0.89	29.19	54.00	-24.81	AVG	

REMARKS:

- (1) Measurement Value = Reading Level + Correct Factor.
- (2) Margin Level = Measurement Value - Limit Value.

Test Mode	IEEE 802.11n (HT40)	Test Date	2022/9/7
Test Frequency	2437MHz	Polarization	Horizontal
Temp	26°C	Hum.	60%

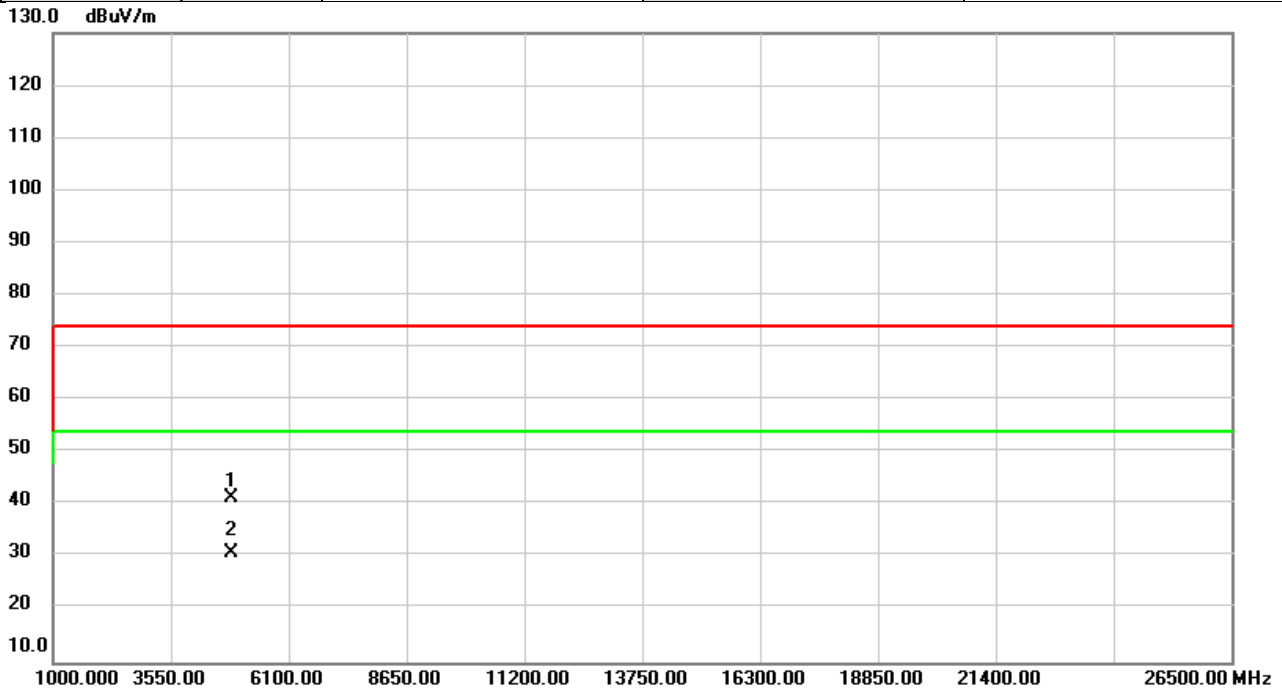

No.	Mk.	Freq. MHz	Reading Level dBuV	Correct Factor dB	Measure- ment dBuV/m	Limit dBuV/m	Over dB	Detector	Comment
1		4874.000	40.32	0.89	41.21	74.00	-32.79	peak	
2	*	4874.000	29.87	0.89	30.76	54.00	-23.24	AVG	

REMARKS:

- (1) Measurement Value = Reading Level + Correct Factor.
- (2) Margin Level = Measurement Value - Limit Value.

Test Mode	IEEE 802.11n (HT40)	Test Date	2022/9/7
Test Frequency	2452MHz	Polarization	Vertical
Temp	26°C	Hum.	60%

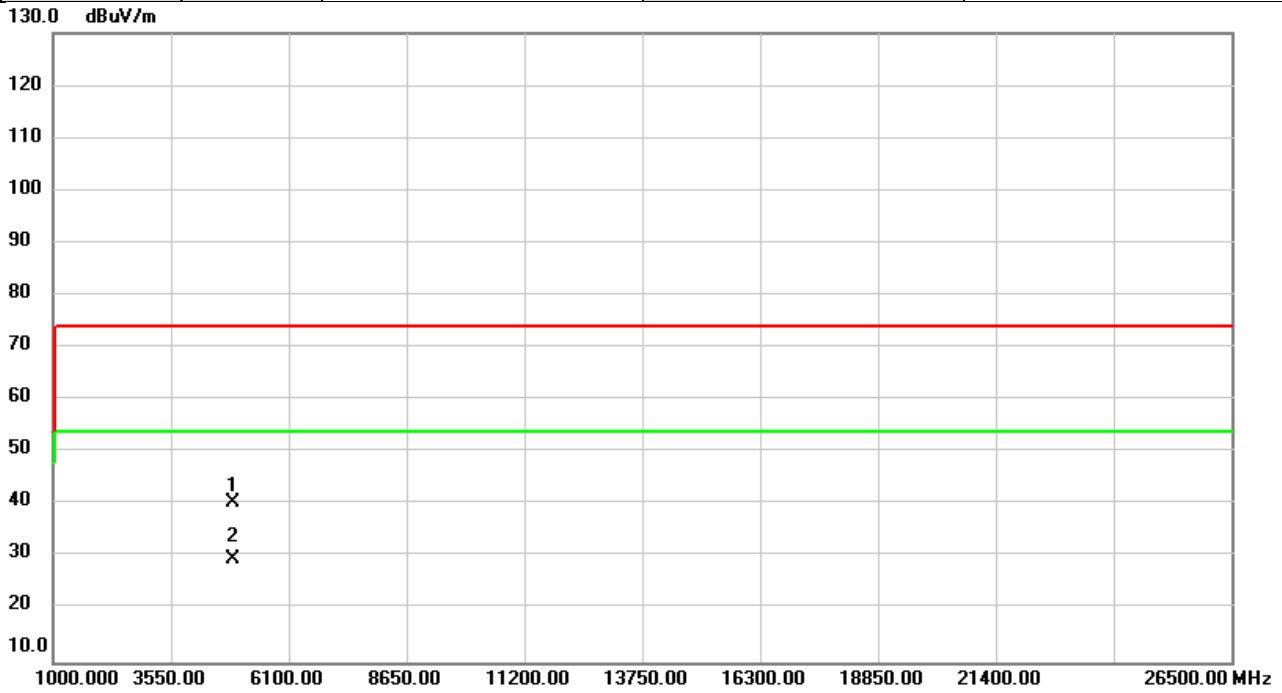

No.	Mk.	Freq. MHz	Reading Level dBuV	Correct Factor dB	Measure- ment dBuV/m	Limit dBuV/m	Over dB	Detector	Comment
1		4904.000	39.51	0.99	40.50	74.00	-33.50	peak	
2	*	4904.000	28.62	0.99	29.61	54.00	-24.39	AVG	

REMARKS:

- (1) Measurement Value = Reading Level + Correct Factor.
- (2) Margin Level = Measurement Value - Limit Value.

Test Mode	IEEE 802.11n (HT40)	Test Date	2022/9/7
Test Frequency	2452MHz	Polarization	Horizontal
Temp	26°C	Hum.	60%

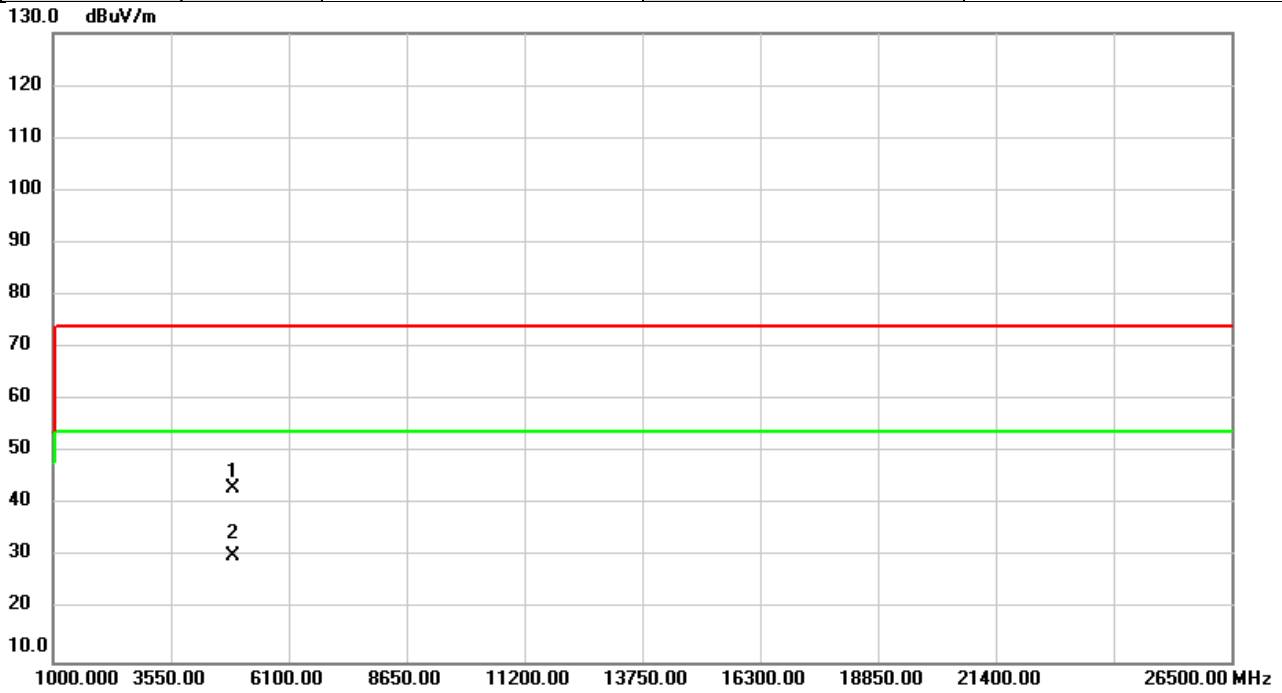

No.	Mk.	Freq. MHz	Reading Level dBuV	Correct Factor dB	Measure- ment dBuV/m	Limit dBuV/m	Over dB	Detector	Comment
1		4904.000	42.15	0.99	43.14	74.00	-30.86	peak	
2	*	4904.000	29.26	0.99	30.25	54.00	-23.75	AVG	

REMARKS:

- (1) Measurement Value = Reading Level + Correct Factor.
- (2) Margin Level = Measurement Value - Limit Value.

APPENDIX D OUTPUT POWER

Test Mode	IEEE 802.11b	Tested Date	2022/9/1
-----------	--------------	-------------	----------

Frequency (MHz)	Conducted Power (dBm)	Conducted Power (W)	Limit (dBm)	Limit (W)	Result
2412	16.45	0.0442	30.00	1.0000	Complies
2437	17.31	0.0538	30.00	1.0000	Complies
2462	16.77	0.0475	30.00	1.0000	Complies

Test Mode	IEEE 802.11g	Tested Date	2022/9/1
-----------	--------------	-------------	----------

Frequency (MHz)	Conducted Power (dBm)	Conducted Power (W)	Limit (dBm)	Limit (W)	Result
2412	11.82	0.0152	30.00	1.0000	Complies
2437	15.94	0.0393	30.00	1.0000	Complies
2462	11.93	0.0156	30.00	1.0000	Complies

Test Mode	IEEE 802.11n (HT20)	Tested Date	2022/9/1
-----------	---------------------	-------------	----------

Frequency (MHz)	Conducted Power (dBm)	Conducted Power (W)	Limit (dBm)	Limit (W)	Result
2412	11.72	0.0149	30.00	1.0000	Complies
2437	15.69	0.0371	30.00	1.0000	Complies
2462	11.94	0.0156	30.00	1.0000	Complies

Test Mode	IEEE 802.11n (HT40)	Tested Date	2022/9/1
-----------	---------------------	-------------	----------

Frequency (MHz)	Conducted Power (dBm)	Conducted Power (W)	Limit (dBm)	Limit (W)	Result
2422	10.77	0.0119	30.00	1.0000	Complies
2437	15.23	0.0333	30.00	1.0000	Complies
2452	14.53	0.0284	30.00	1.0000	Complies

End of Test Report