



**FCC 47 CFR PART 15 SUBPART C
INDUSTRY CANADA RSS-247 ISSUE 1
CLASS II PERMISSIVE CHANGE**

**BLUETOOTH LOW ENERGY
CERTIFICATION TEST REPORT**

FOR

BLE MODULE

MODEL NUMBER: ORB

**FCC ID: 2AB8ZND14
IC: 1000X-ND14**

REPORT NUMBER: 16U22854-E1V2

ISSUE DATE: MARCH 11, 2016

Prepared for
**INTEL CORPORATION
2200 MISSION COLLEGE BOULEVARD,
SANTA CLARA, CA 95052, U.S.A**

Prepared by
**UL VERIFICATION SERVICES INC.
47173 BENICIA STREET
FREMONT, CA 94538, U.S.A.
TEL: (510) 771-1000
FAX: (510) 661-0888**



NVLAP LAB CODE 200065-0

Revision History

<u>Rev.</u>	<u>Issue Date</u>	<u>Revisions</u>	<u>Revised By</u>
V1	03/09/2016	Initial Issue	C. Pang
V2	03/09/2016	Address TCB's Question	C. Pang

TABLE OF CONTENTS

1. ATTESTATION OF TEST RESULTS	4
2. TEST METHODOLOGY	5
3. FACILITIES AND ACCREDITATION	5
4. CALIBRATION AND UNCERTAINTY	6
4.1. <i>MEASURING INSTRUMENT CALIBRATION</i>	<i>6</i>
4.2. <i>SAMPLE CALCULATION</i>	<i>6</i>
4.3. <i>MEASUREMENT UNCERTAINTY.....</i>	<i>6</i>
5. EQUIPMENT UNDER TEST	7
5.1. <i>DESCRIPTION OF EUT</i>	<i>7</i>
5.2. <i>MAXIMUM OUTPUT POWER.....</i>	<i>7</i>
5.3. <i>DESCRIPTION OF AVAILABLE ANTENNAS</i>	<i>7</i>
5.4. <i>SOFTWARE AND FIRMWARE.....</i>	<i>7</i>
5.5. <i>DESCRIPTION OF CLASS II PERMISSIVE CHANGE</i>	<i>7</i>
5.6. <i>WORST-CASE CONFIGURATION AND MODE.....</i>	<i>7</i>
5.7. <i>DESCRIPTION OF TEST SETUP.....</i>	<i>8</i>
6. TEST AND MEASUREMENT EQUIPMENT	13
7. ANTENNA PORT TEST RESULTS	14
7.1. <i>MEASUREMENT METHODS</i>	<i>14</i>
7.2. <i>6 dB BANDWIDTH.....</i>	<i>17</i>
7.3. <i>99% BANDWIDTH.....</i>	<i>19</i>
7.4. <i>OUTPUT POWER.....</i>	<i>21</i>
7.5. <i>AVERAGE POWER.....</i>	<i>23</i>
7.6. <i>POWER SPECTRAL DENSITY</i>	<i>24</i>
7.7. <i>CONDUCTED SPURIOUS EMISSIONS.....</i>	<i>26</i>
8. RADIATED TEST RESULTS.....	29
8.1. <i>LIMITS AND PROCEDURE</i>	<i>29</i>
8.2. <i>TRANSMITTER ABOVE 1 GHz.....</i>	<i>30</i>
8.3. <i>WORST-CASE BELOW 1 GHz.....</i>	<i>42</i>
8.4. <i>WORST-CASE 18 – 26 GHz.....</i>	<i>44</i>
8.5. <i>AC POWER LINE CONDUCTED EMISSIONS</i>	<i>46</i>
9. SETUP PHOTOS.....	63

1. ATTESTATION OF TEST RESULTS

COMPANY NAME: INTEL CORPORATION
2200 MISSION COLLEGE BOULEVARD
SANTA CLARA, CA 95052, U.S.A.

EUT DESCRIPTION: BLE MODULE

MODEL: ORB

SERIAL NUMBER: 03-72 & 02-54 (CONDUCTED); 006 & 090 (RADIATED)

DATE TESTED: FEBRUARY 11, 2016 – MARCH 08, 2016

APPLICABLE STANDARDS	
STANDARD	TEST RESULTS
CFR 47 Part 15 Subpart C	Pass
INDUSTRY CANADA RSS-247 Issue 1	Pass
INDUSTRY CANADA RSS-GEN Issue 4	Pass

UL Verification Services Inc. tested the above equipment in accordance with the requirements set forth in the above standards. All indications of Pass/Fail in this report are opinions expressed by UL Verification Services Inc. based on interpretations and/or observations of test results. Measurement Uncertainties were not taken into account and are published for informational purposes only. The test results show that the equipment tested is capable of demonstrating compliance with the requirements as documented in this report.

Note: The results documented in this report apply only to the tested sample, under the conditions and modes of operation as described herein. This document may not be altered or revised in any way unless done so by UL Verification Services Inc. and all revisions are duly noted in the revisions section. Any alteration of this document not carried out by UL Verification Services Inc. will constitute fraud and shall nullify the document. This report must not be used by the client to claim product certification, approval, or endorsement by NVLAP, NIST, any agency of the Federal Government, or any agency of any government.

Approved & Released For
UL Verification Services Inc. By:



CHIN PANG
EMC SENIOR ENGINEER
UL VERIFICATION SERVICES INC.

Tested By:

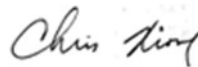

CHRIS XIONG
EMC ENGINEER
UL VERIFICATION SERVICES INC.

2. TEST METHODOLOGY

The tests documented in this report were performed in accordance with FCC CFR 47 Part 2, FCC CFR 47 Part 15, ANSI C63.10-2013, RSS-GEN Issue 4 and RSS-247 Issue 1.

3. FACILITIES AND ACCREDITATION

The test sites and measurement facilities used to collect data are located at 47173 and 47266 Benicia Street, Fremont, California, USA. Line conducted emissions are measured only at the 47173 address. The following table identifies which facilities were utilized for radiated emission measurements documented in this report. Specific facilities are also identified in the test results sections.

47173 Benicia Street	47266 Benicia Street
<input type="checkbox"/> Chamber A	<input type="checkbox"/> Chamber D
<input type="checkbox"/> Chamber B	<input type="checkbox"/> Chamber E
<input type="checkbox"/> Chamber C	<input type="checkbox"/> Chamber F
	<input type="checkbox"/> Chamber G
	<input checked="" type="checkbox"/> Chamber H

The above test sites and facilities are covered under FCC Test Firm Registration # 208313. Chambers A through H are covered under Industry Canada company address code 2324B with site numbers 2324B -1 through 2324B-8, respectively.

UL Verification Services Inc. is accredited by NVLAP, Laboratory Code 200065-0. The full scope of accreditation can be viewed at <http://ts.nist.gov/standards/scopes/2000650.htm>.

4. CALIBRATION AND UNCERTAINTY

4.1. MEASURING INSTRUMENT CALIBRATION

The measuring equipment utilized to perform the tests documented in this report has been calibrated in accordance with the manufacturer's recommendations, and is traceable to recognized national standards.

4.2. SAMPLE CALCULATION

Where relevant, the following sample calculation is provided:

$$\begin{aligned} \text{Field Strength (dBuV/m)} &= \text{Measured Voltage (dBuV)} + \text{Antenna Factor (dB/m)} + \\ &\text{Cable Loss (dB)} - \text{Preamp Gain (dB)} \\ 36.5 \text{ dBuV} + 18.7 \text{ dB/m} + 0.6 \text{ dB} - 26.9 \text{ dB} &= 28.9 \text{ dBuV/m} \end{aligned}$$

4.3. MEASUREMENT UNCERTAINTY

Where relevant, the following measurement uncertainty levels have been estimated for tests performed on the apparatus:

PARAMETER	UNCERTAINTY
Conducted Disturbance, 0.15 to 30 MHz	± 3.52 dB
Radiated Disturbance, 30 to 1000 MHz	± 4.94 dB
Radiated Disturbance, 1 to 6 GHz	± 3.86 dB
Radiated Disturbance, 6 to 18 GHz	± 4.23 dB
Radiated Disturbance, 18 to 26 GHz	± 5.30 dB
Radiated Disturbance, 26 to 40 GHz	± 5.23 dB

Uncertainty figures are valid to a confidence level of 95%.

5. EQUIPMENT UNDER TEST

5.1. DESCRIPTION OF EUT

The EUT is a BLE module that has been previously assessed over the frequency range of 2402 to 2480 MHz under test report number 15U22570-E1V1.

The device has been modified to extend the frequency range from 2401 to 2481 MHz. The hardware remained unchanged.

This report covers the evaluation of only the 2401 MHz and 2481 MHz frequencies. Testing of the center frequency was deemed unnecessary since was covered during original evaluation.

5.2. MAXIMUM OUTPUT POWER

The transmitter has a maximum peak conducted output power as follows:

Frequency Range (MHz)	Mode	Output Power (dBm)	Output Power (mW)
2401	BLE	-2.18	0.61
2481	BLE	-1.69	0.68

5.3. DESCRIPTION OF AVAILABLE ANTENNAS

The radio utilizes a chip antenna, with a maximum gain of 1.7 dBi.

5.4. SOFTWARE AND FIRMWARE

The firmware installed in the EUT during testing was MFG.

5.5. DESCRIPTION OF CLASS II PERMISSIVE CHANGE

The purpose of this C2PC is to include the operating frequency of 2401 and 2481MHz.

5.6. WORST-CASE CONFIGURATION AND MODE

Radiated emission and power line conducted emission were performed with the EUT set to transmit at the channel with highest output power as worst-case scenario.

The fundamental of the EUT was investigated in three orthogonal orientations X, Y and Z, it was determined that Y orientation was worst-case orientation; therefore, all final radiated testing was performed with the EUT in Y orientation.

Worst-case data rates as provided by the client were:

BLE: 1 Mbps.

5.7. DESCRIPTION OF TEST SETUP

SUPPORT EQUIPMENT

Support Equipment List				
Description	Manufacturer	Model	Serial Number	FCC ID
Laptop	Lenovo	Yoga 2 11	YB04282152	N/A
AC Adapter	Lenovo	ADLX45NDC3A	11S45N0289Z1ZS9K4	N/A
Test Board	Intel	Debug Ext Board H86706-100	CRBPR1SQ5460194	N/A

I/O CABLES

I/O Cable List					
Cable No	Port	# of identical ports	Connector Type	Cable Type	Cable Length (m)
1	AC	1	3-Prong	Un-Shielded	1.8
2	DC	1	DC	Un-Shielded	1
3	USB	1	USB	Shielded	1.8
4	Serial	1	Ribbon Cable Connector	Un-Shielded	0.25
5	Antenna	1	SMA	Un-Shielded	0.025

TEST SETUP

Test software exercised the radio card.

SETUP DIAGRAM FOR CONDUCTED TESTS

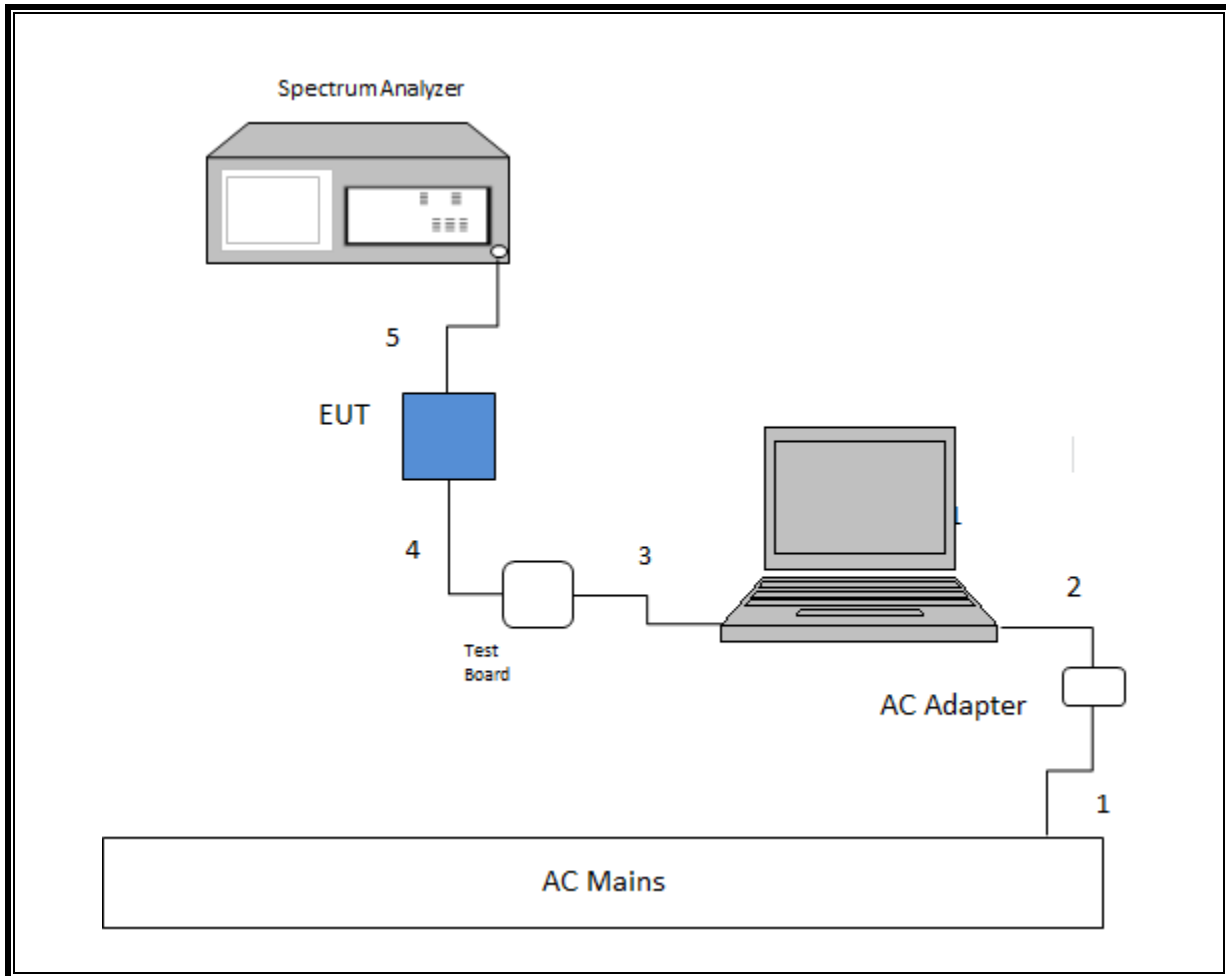

SETUP DIAGRAM FOR RADIATED TESTS

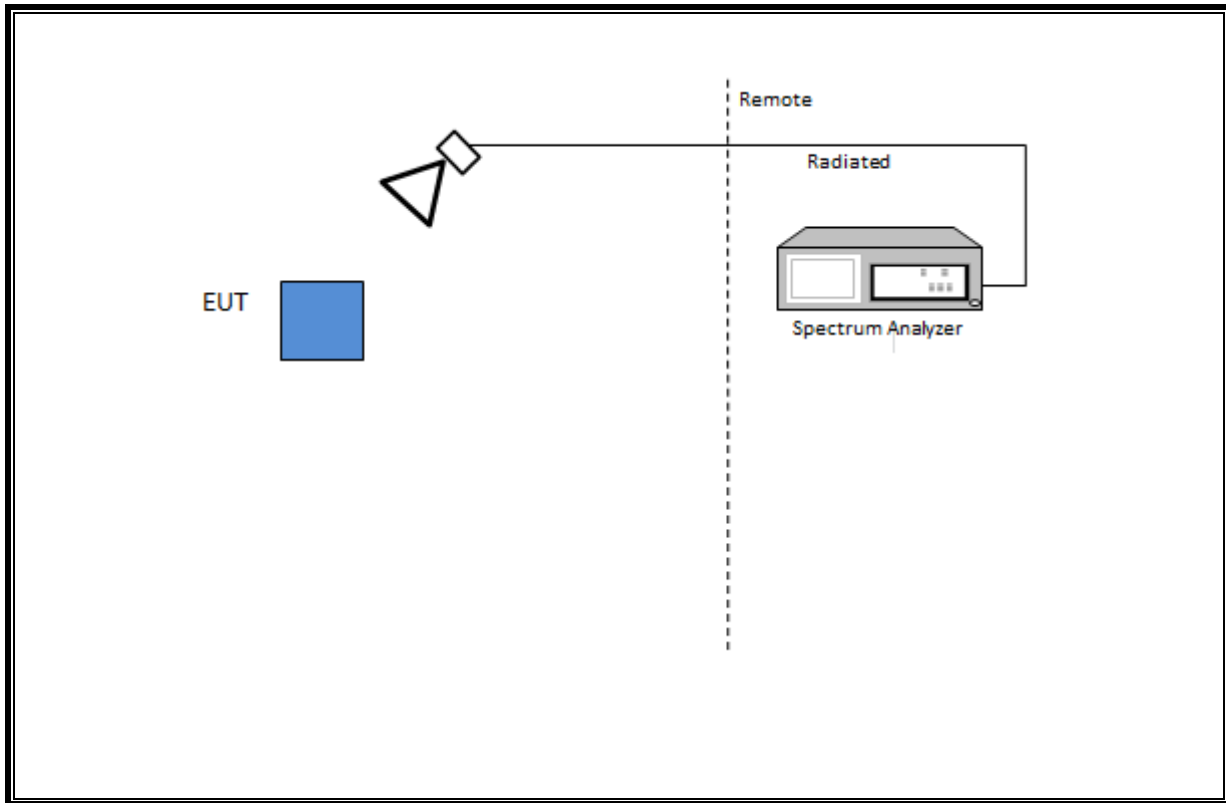

SETUP DIAGRAM FOR LINE CONDUCTED TEST – EUT ONLY

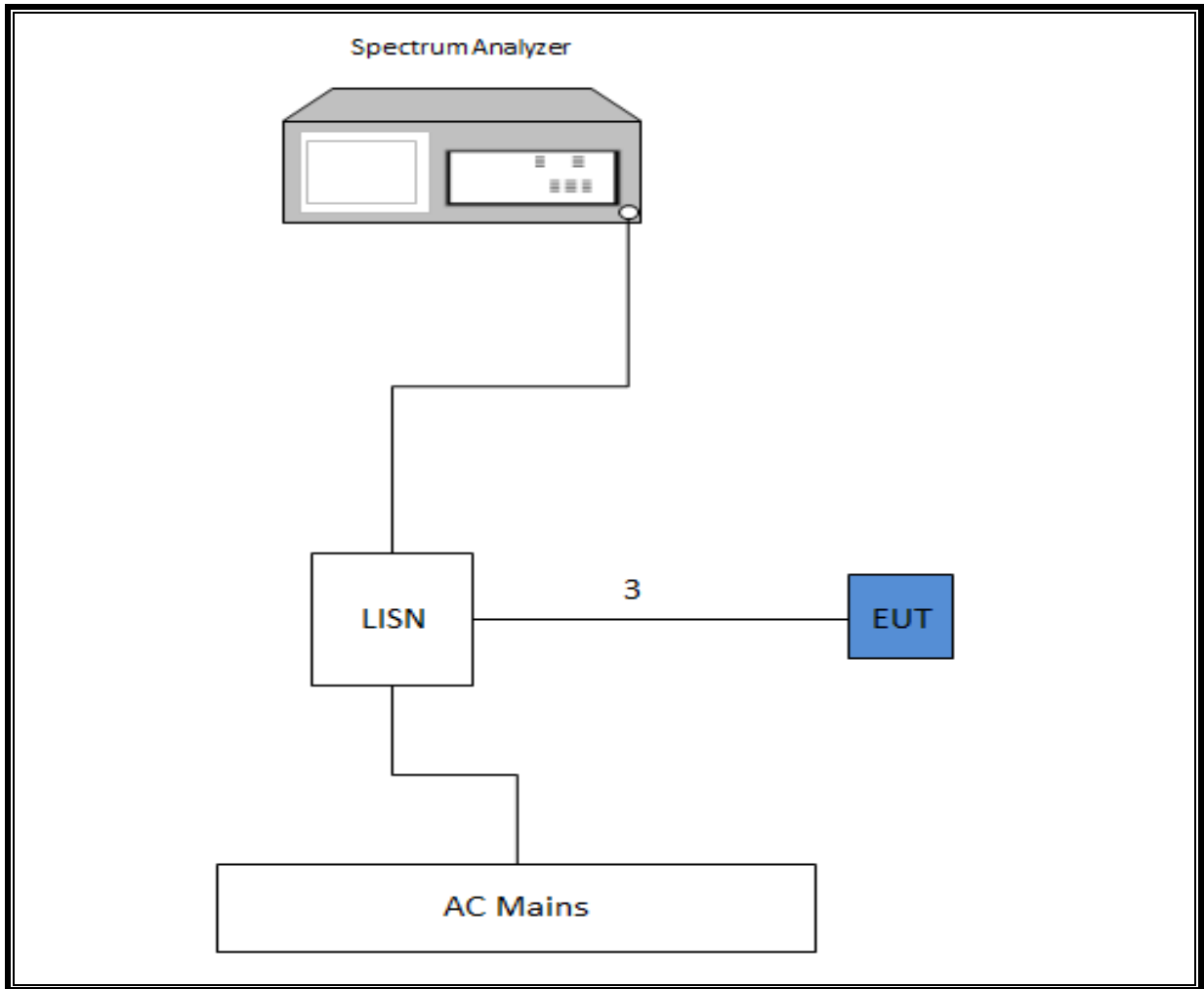

SETUP DIAGRAM FOR LINE CONDUCTED TEST – LAPTOP SETUP

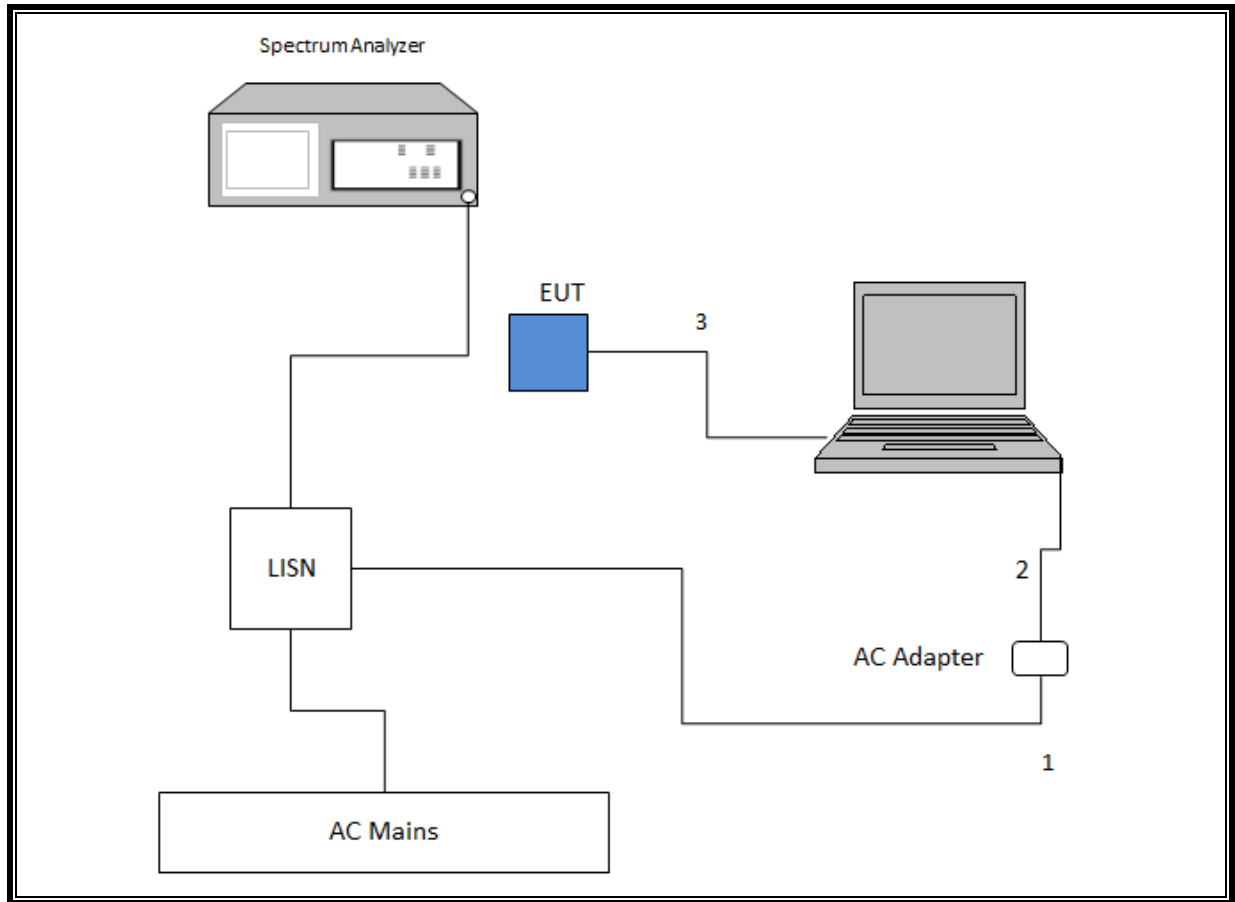

6. TEST AND MEASUREMENT EQUIPMENT

The following test and measurement equipment was utilized for the tests documented in this report:

Test Equipment List					
Description	Manufacturer	Model	T No.	Cal Date	Cal Due
Radiated Software	UL	UL EMC	Ver 9.5		
Conducted Software	UL	UL EMC	Ver 4.1		
Spectrum Analyzer, PXA, 3Hz to 44GHz	Keysight	N9030A	PRE0126763	12/9/2015	12/9/2016
Antenna, Horn 1-18GHz	ETS Lindgren	3117	863	4/10/2015	4/10/2016
Antenna, Broadband Hybrid, 30 to 2000MHz	Sunol Sciences	JB3	900	4/10/2015	4/10/2016
Amplifier, 1-18GHz	Miteq	AFS42-00101800-25-S-42	495	10/21/2015	10/21/2016
Spectrum Analyzer, PXA, 3Hz to 44GHz	Keysight	N9030A	1210	5/22/2015	5/22/2016
Amplifier, 10kHz to 1GHz	Sonoma	310N	835	6/9/2015	6/9/2016
Power Meter	Keysight	N1911A	1244	7/2/2015	7/2/2016
Power Sensor	Keysight	N1921A	1226	7/6/2015	7/6/2016
Amplifier, 1-26.5GHz	Keysight	8449B	404	6/29/2015	6/29/2016
Antenna, Horn 18 - 26GHz	ARA	MWH-1826	447	5/12/2015	5/12/2016
Spectrum Analyzer, 40GHz	Keysight	8564E	106	8/14/2015	8/14/2016
EMI Test Receiver	Rohde & Schwarz	ESR	1436	12/19/2015	12/19/2016
LISN for Conducted Emissions CISPR-16	Fischer	FCC-LISN-50/250/25/2/01/CISPR16	1310	9/16/2015	9/16/2016

7. ANTENNA PORT TEST RESULTS

7.1. MEASUREMENT METHODS

6 dB BW: KDB 558074 D01 v03r04, Section 8.1.

Output Power: KDB 558074 D01 v03r04, Section 9.1.2.

Power Spectral Density: KDB 558074 D01 v03r04, Section 10.2.

Out-of-band emissions in non-restricted bands: KDB 558074 D01 v03r04, Section 11.0.

Out-of-band emissions in restricted bands: KDB 558074 D01 v03r04, Section 12.1.

Band-edge: KDB 558074 D01 v03r04, Section 13.3.3

ON TIME, DUTY CYCLE

None; for reporting purposes only.

PROCEDURE

KDB 558074 Zero-Span Spectrum Analyzer Method.

ON TIME AND DUTY CYCLE RESULTS

Mode	Frequency (MHz)	ON Time B (msec)	Period (msec)	Duty Cycle x (linear)	Duty Cycle (%)	Duty Cycle Correction Factor (dB)	1/B Minimum VBW (kHz)
BLE	2401	0.412	34.920	0.012	1.18%	19.28	2.427
BLE	2481	0.420	30.120	0.014	1.39%	18.56	2.381

DUTY CYCLE PLOTS

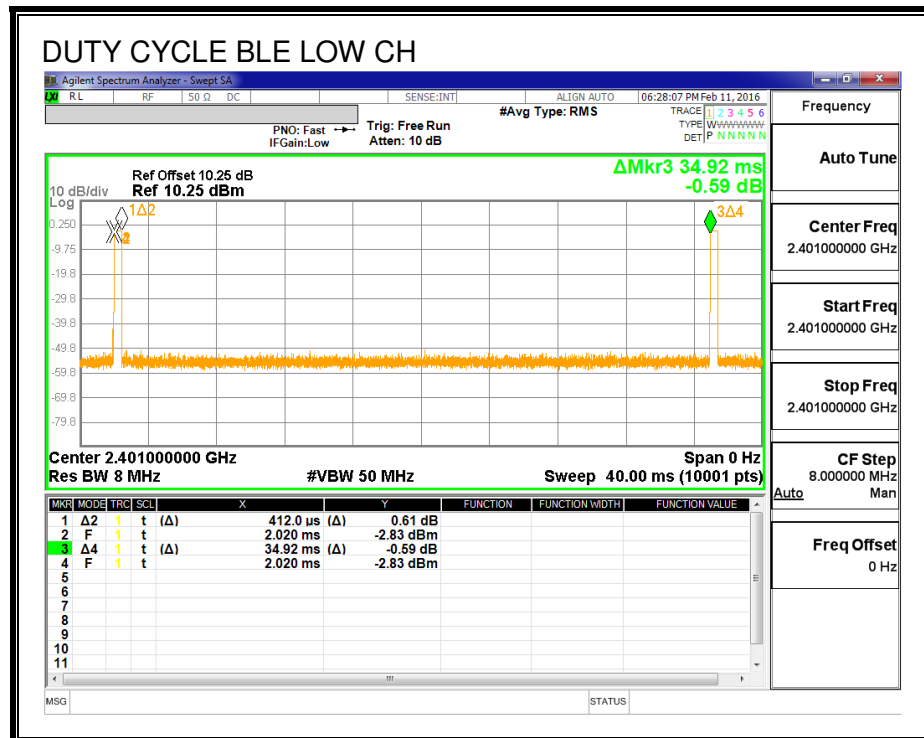

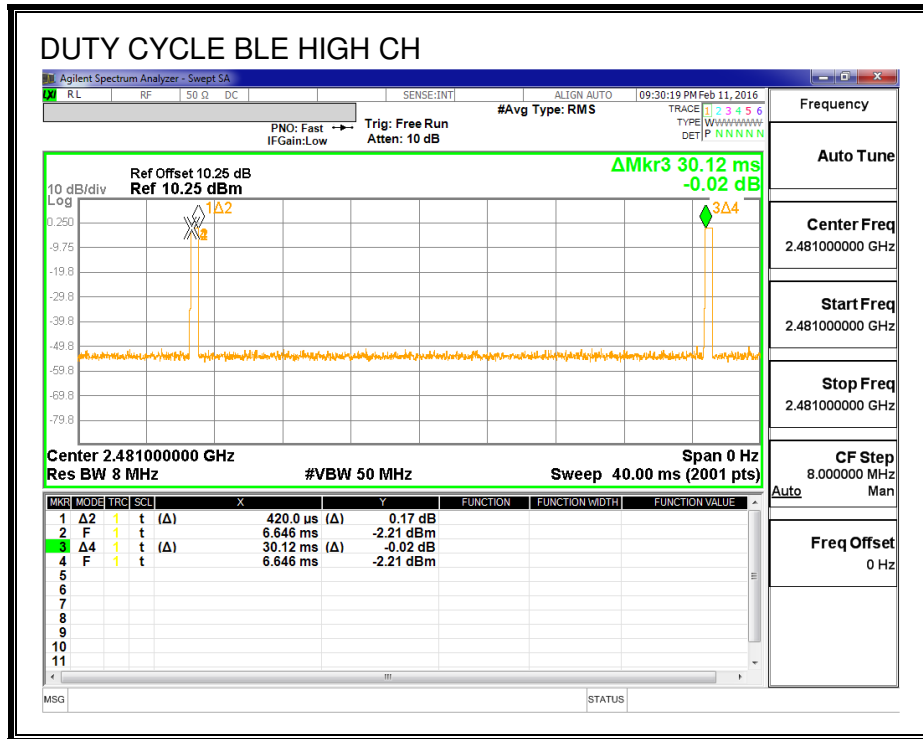

7.2. 6 dB BANDWIDTH

LIMITS

FCC §15.247 (a) (2)

IC RSS-247 (5.2) (1)

The minimum 6 dB bandwidth shall be at least 500 kHz.

RESULTS

Channel	Frequency (MHz)	6 dB Bandwidth (MHz)	Minimum Limit (MHz)
Low	2401	0.648	0.5
High	2481	0.677	0.5

6 dB BANDWIDTH

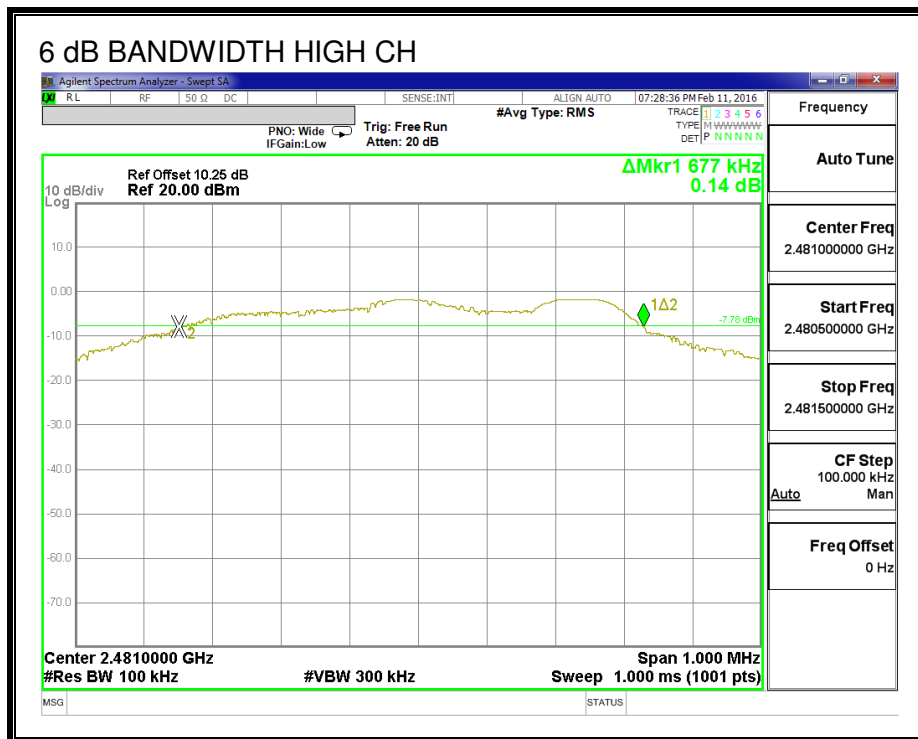
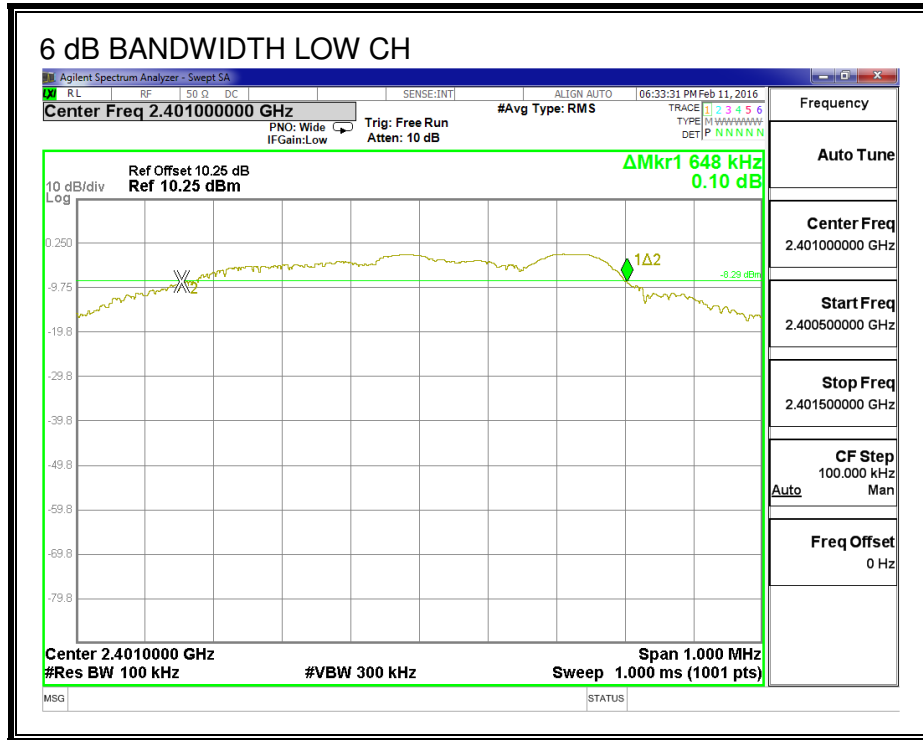

7.3. 99% BANDWIDTH

LIMITS

None; for reporting purposes only.

TEST PROCEDURE

The transmitter output is connected to the spectrum analyzer. The RBW is set to 1% to 3% of the 99 % bandwidth and to 1% of the span. The VBW is set to 3 times the RBW. The sweep time is coupled. The spectrum analyzer internal 99% bandwidth function is utilized.

RESULTS

Frequency (MHz)	99% Bandwidth (MHz)
2401	0.95508
2481	0.95836

99% BANDWIDTH

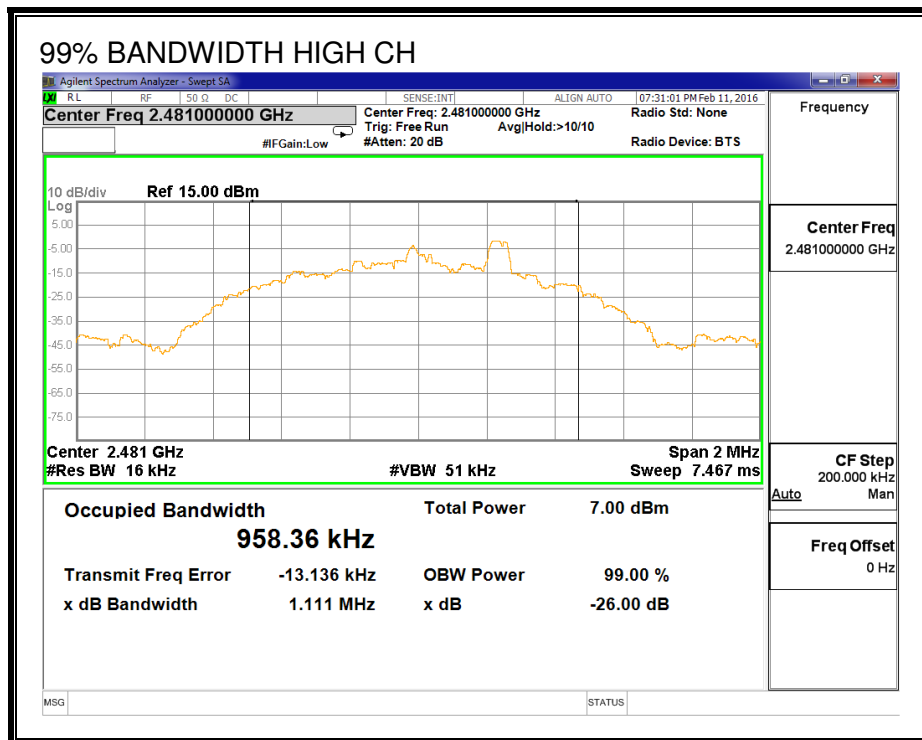
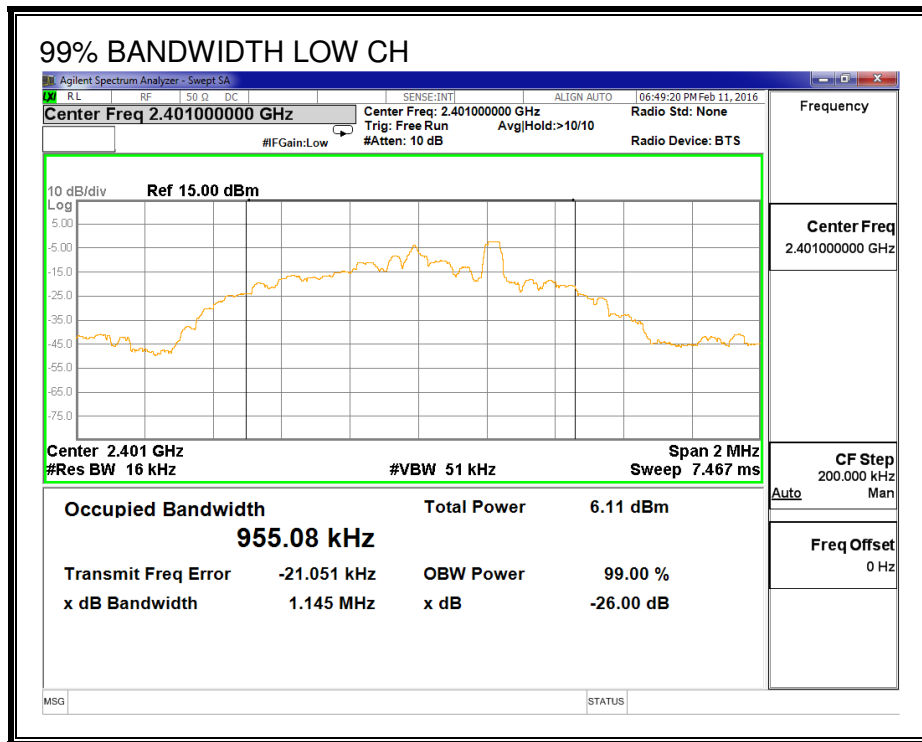

7.4. OUTPUT POWER

LIMITS

FCC §15.247 (b)

IC RSS-247 (5.4) (4)

The maximum antenna gain is less than or equal to 6 dBi, therefore the limit is 30 dBm.

RESULTS

Channel	Frequency (MHz)	Peak Power Reading (dBm)	Limit (dBm)	Margin (dB)
Low	2401	-2.179	30	-32.179
High	2481	-1.687	30	-31.687

OUTPUT POWER

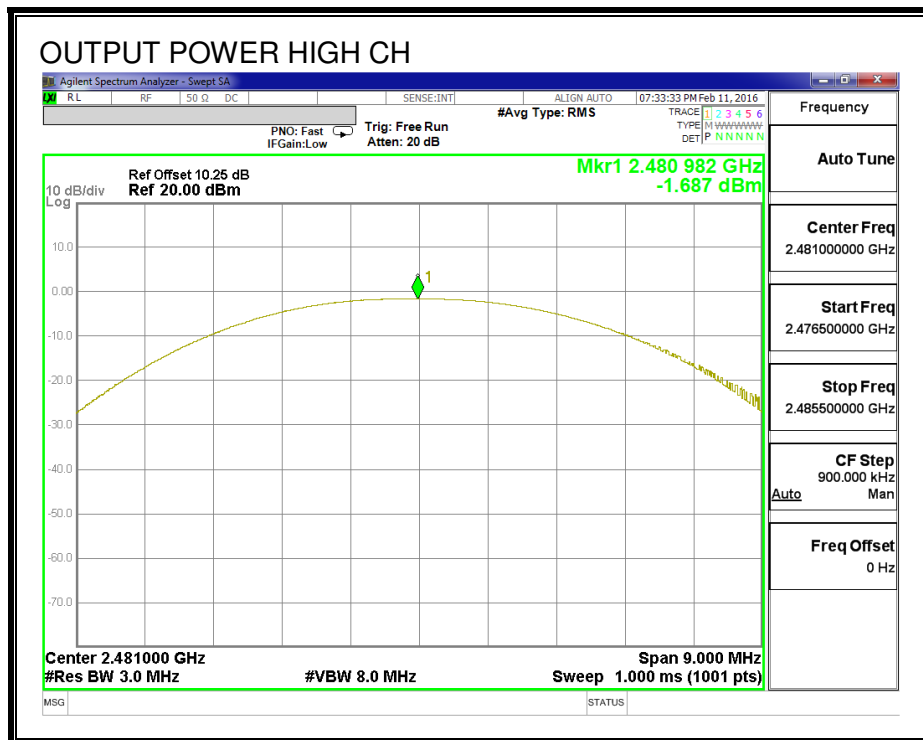
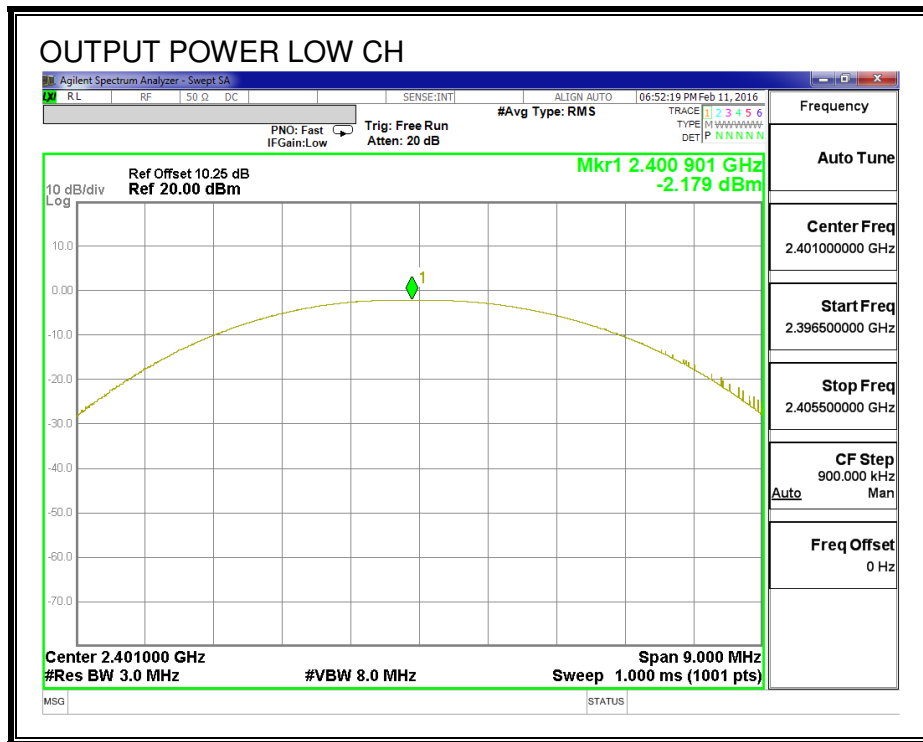

7.5. AVERAGE POWER

LIMITS

None; for reporting purposes only.

RESULTS

The cable assembly insertion loss of 10.25 dB (including 10 dB pad and 0.25 dB cable) was entered as an offset in the power meter to allow for direct reading of power.

Channel	Frequency (MHz)	AV power (dBm)
Low	2401	-2.30
High	2481	-1.82

7.6. POWER SPECTRAL DENSITY

LIMITS

FCC §15.247 (e)

IC RSS-247 (5.2) (2)

The power spectral density conducted from the transmitter to the antenna shall not be greater than 8 dBm in any 3 kHz band during any time interval of continuous transmission.

RESULTS

Channel	Frequency (MHz)	PSD (dBm)	Limit (dBm)	Margin (dB)
Low	2401	-2.249	8	-10.25
High	2481	-1.772	8	-9.77

POWER SPECTRAL DENSITY

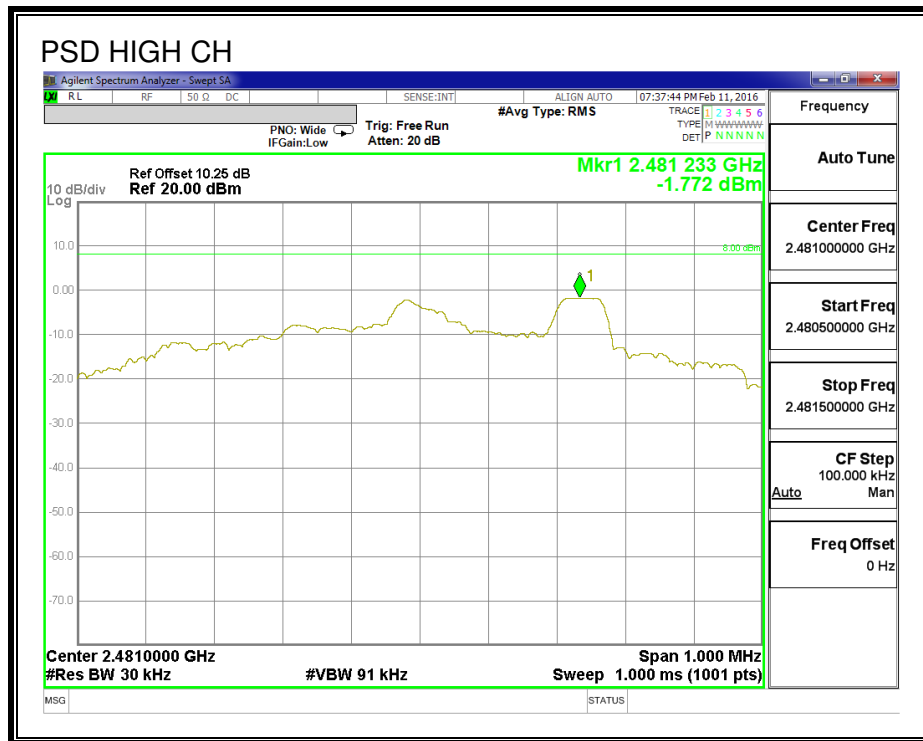
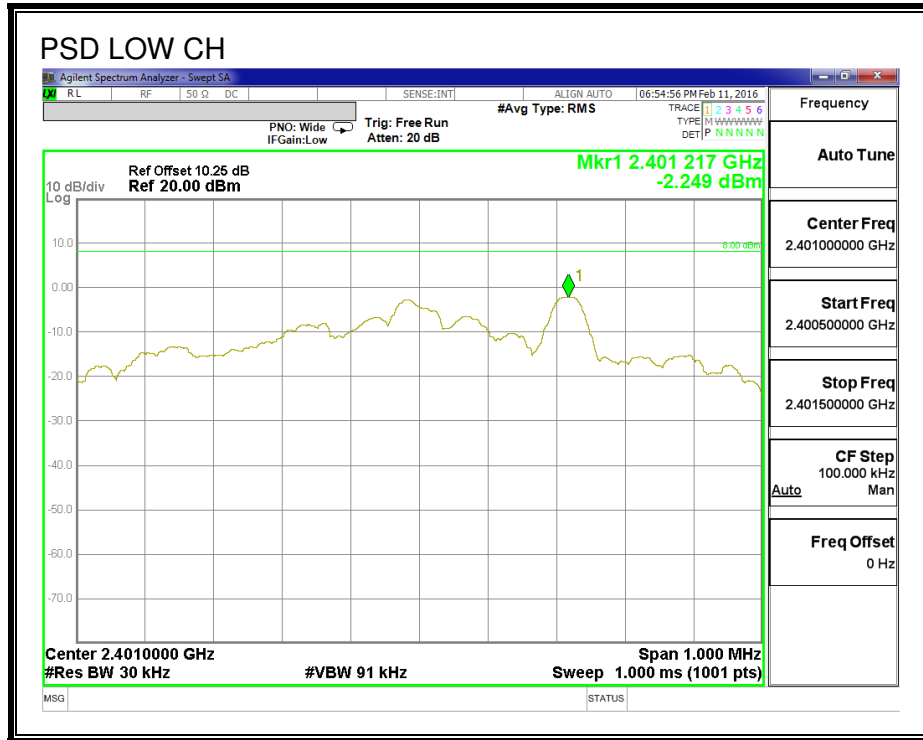

7.7. CONDUCTED SPURIOUS EMISSIONS

LIMITS

FCC §15.247 (d)

IC RSS-247 (5.5)

Output power was measured based on the use of a peak measurement, therefore the required attenuation is 20 dB.

RESULTS

SPURIOUS EMISSIONS, LOW CHANNEL

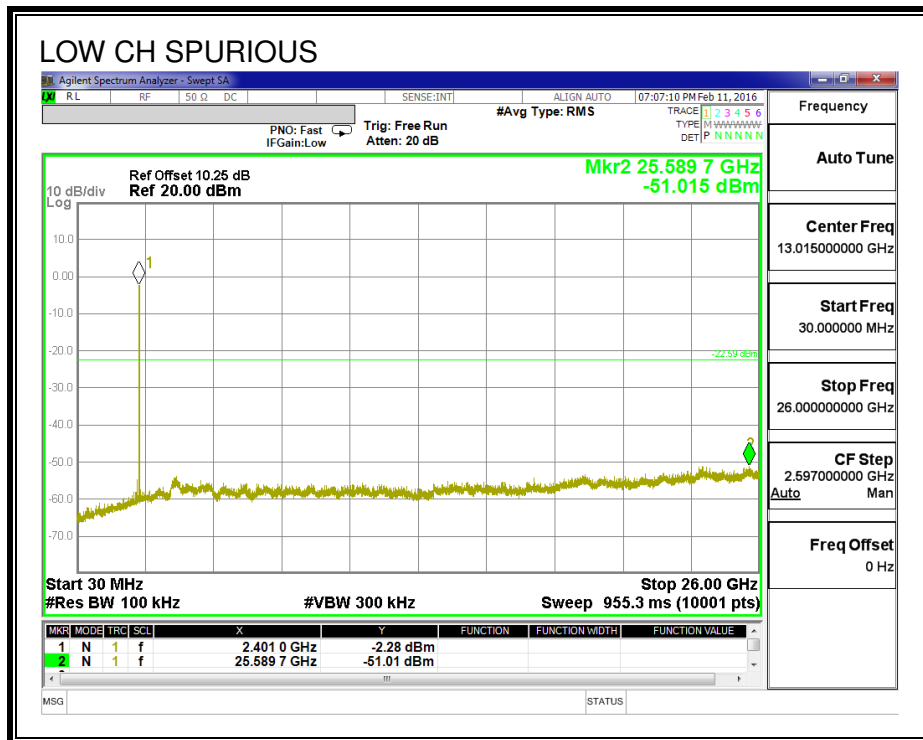
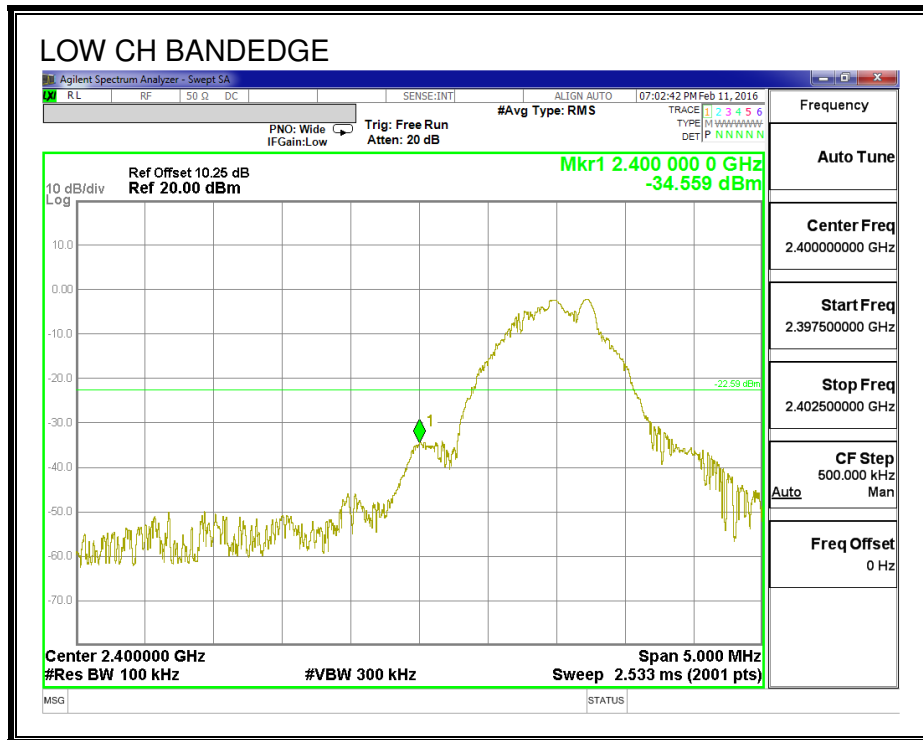

SPURIOUS EMISSIONS, HIGH CHANNEL

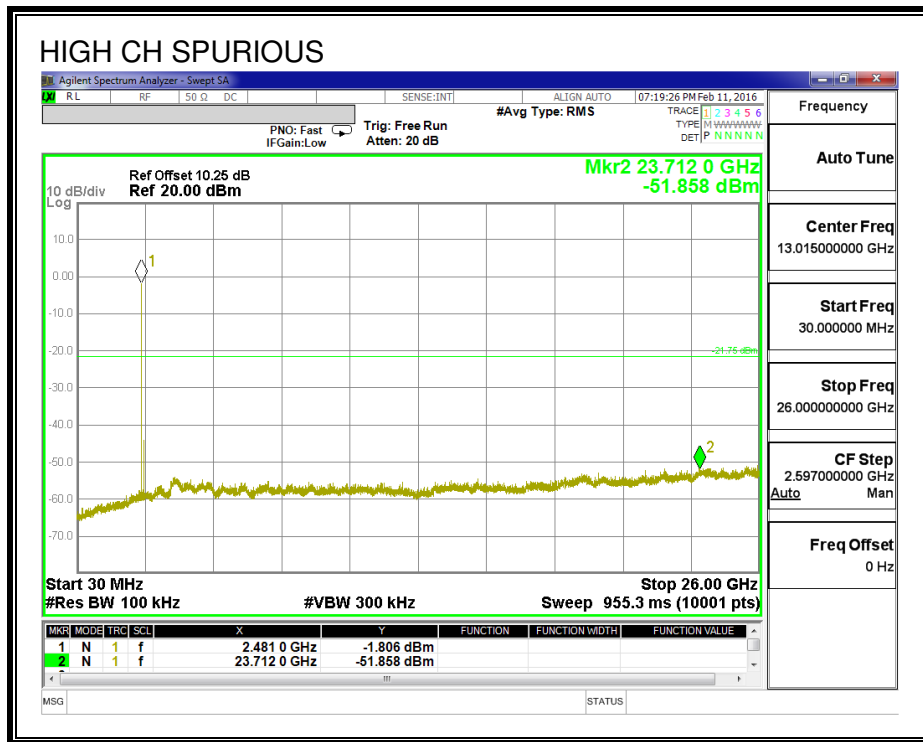
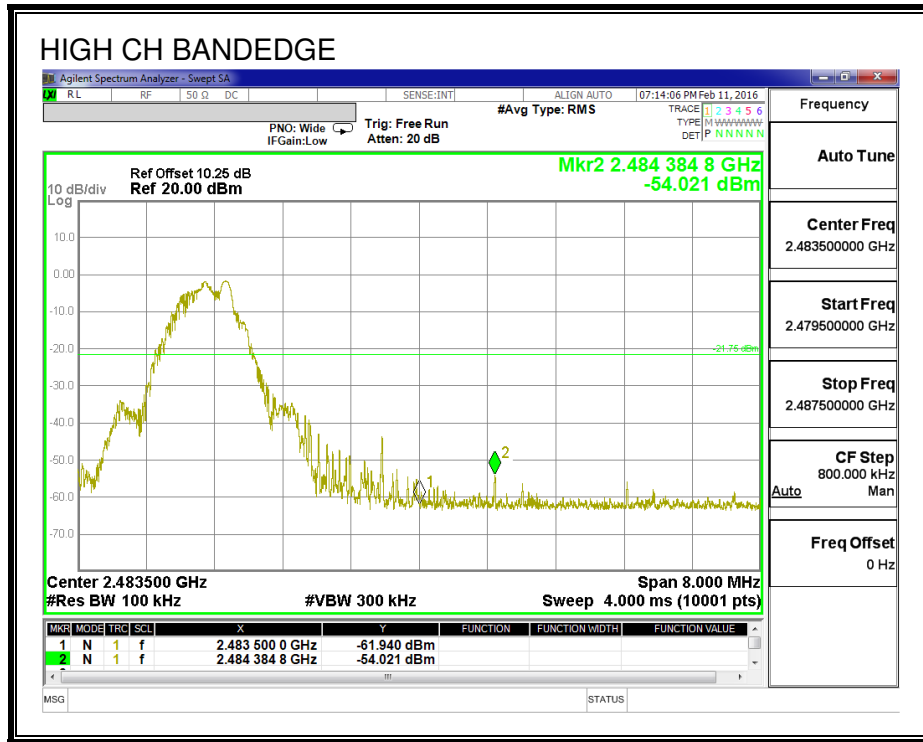

8. RADIATED TEST RESULTS

8.1. LIMITS AND PROCEDURE

LIMITS

FCC §15.205 and §15.209

IC RSS-GEN Clause 8.9 and 8.10

Frequency Range (MHz)	Field Strength Limit (uV/m) at 3 m	Field Strength Limit (dBuV/m) at 3 m
30 - 88	100	40
88 - 216	150	43.5
216 - 960	200	46
Above 960	500	54

TEST PROCEDURE

The EUT is placed on a non-conducting table 80 cm above the ground plane for measurement below 1GHz; 1.5 m above the ground plane for measurement above 1GHz. The antenna to EUT distance is 3 meters. The EUT is configured in accordance with ANSI C63.10. The EUT is set to transmit in a continuous mode.

For measurements below 1 GHz the resolution bandwidth is set to 100 kHz for peak detection measurements or 120 kHz for quasi-peak detection measurements. Peak detection is used unless otherwise noted as quasi-peak.

For measurements above 1 GHz the resolution bandwidth is set to 1 MHz, then the video bandwidth is set to 3 MHz for peak measurements and 1 MHz resolution bandwidth with 3MHz video bandwidth with average detector for average measurements.

The spectrum from 30 MHz to 26 GHz is investigated with the transmitter set to the lowest, middle, and highest channels in the 2.4 GHz band.

The frequency range of interest is monitored at a fixed antenna height and EUT azimuth. The EUT is rotated through 360 degrees to maximize emissions received. The antenna is scanned from 1 to 4 meters above the ground plane to further maximize the emission. Measurements are made with the antenna polarized in both the vertical and the horizontal positions.

8.2. TRANSMITTER ABOVE 1 GHz

RESTRICTED BANDEDGE (LOW CHANNEL)

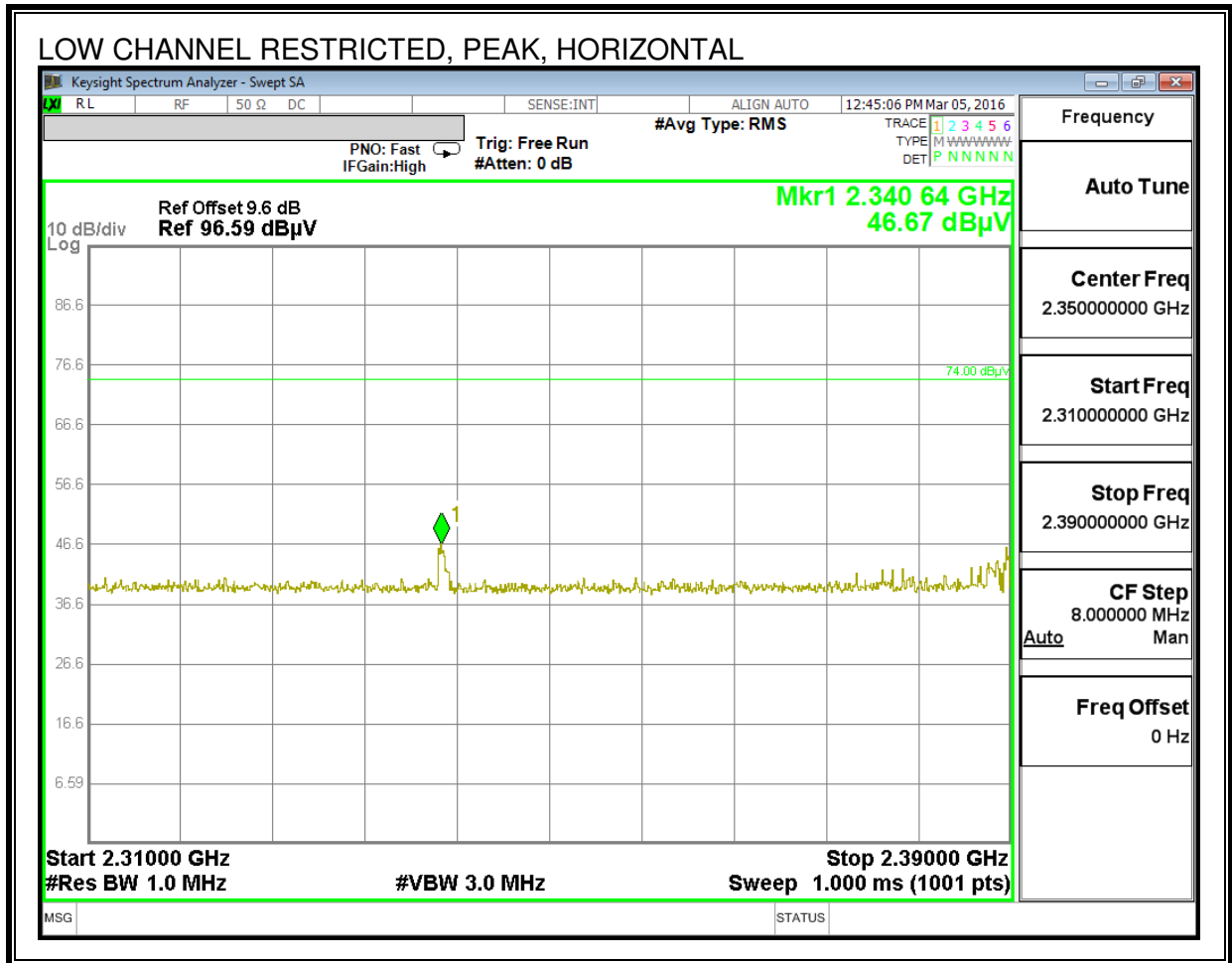

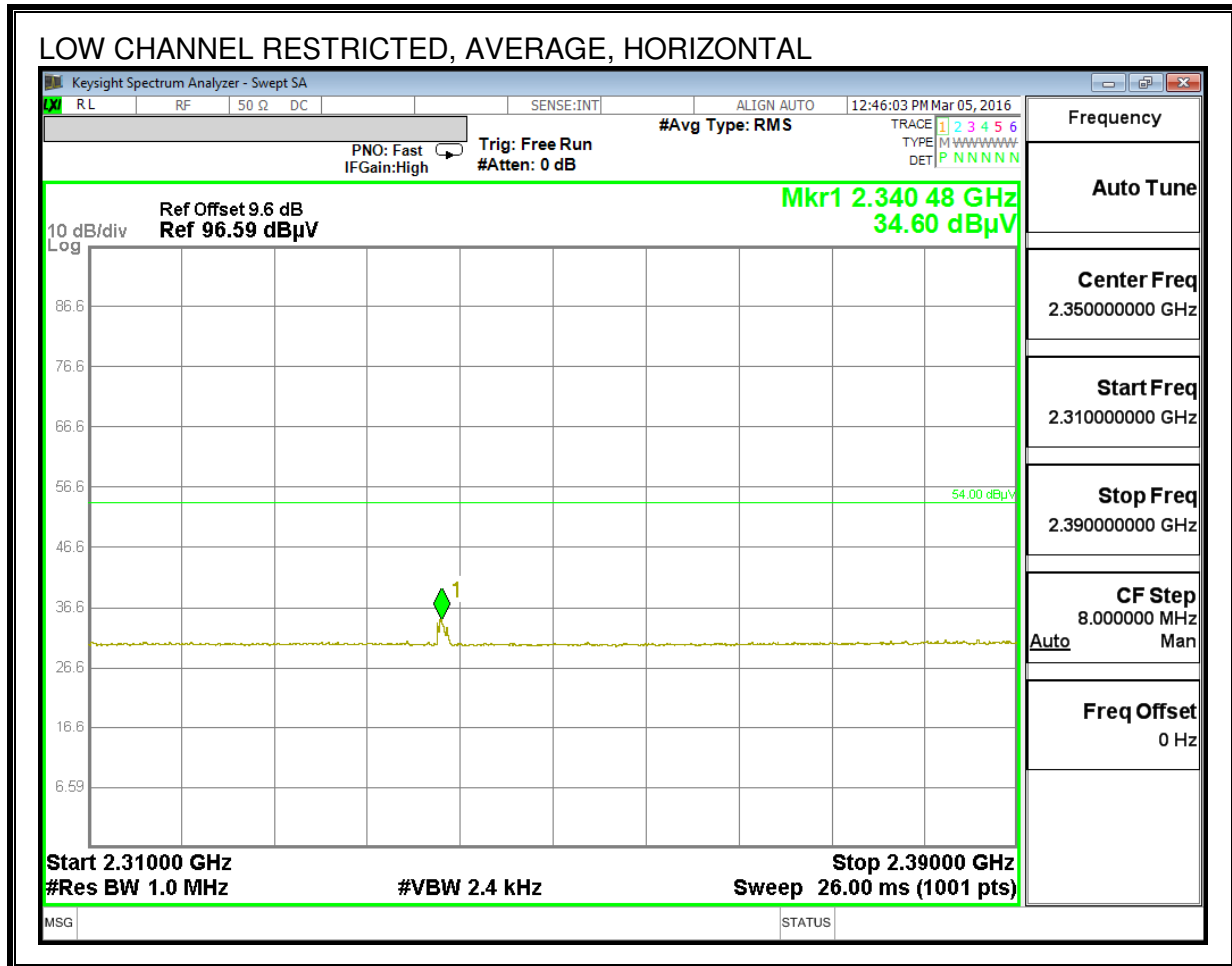

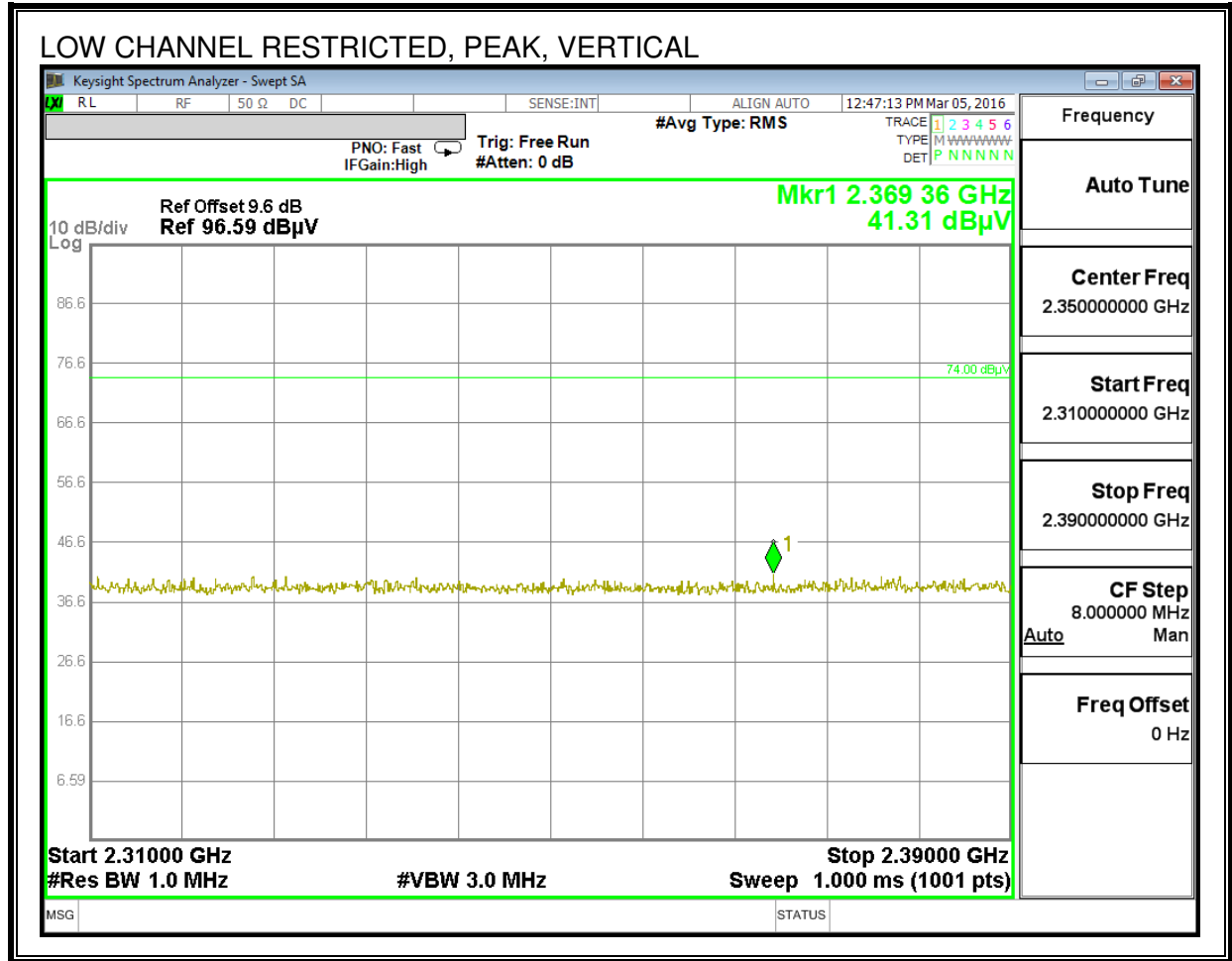

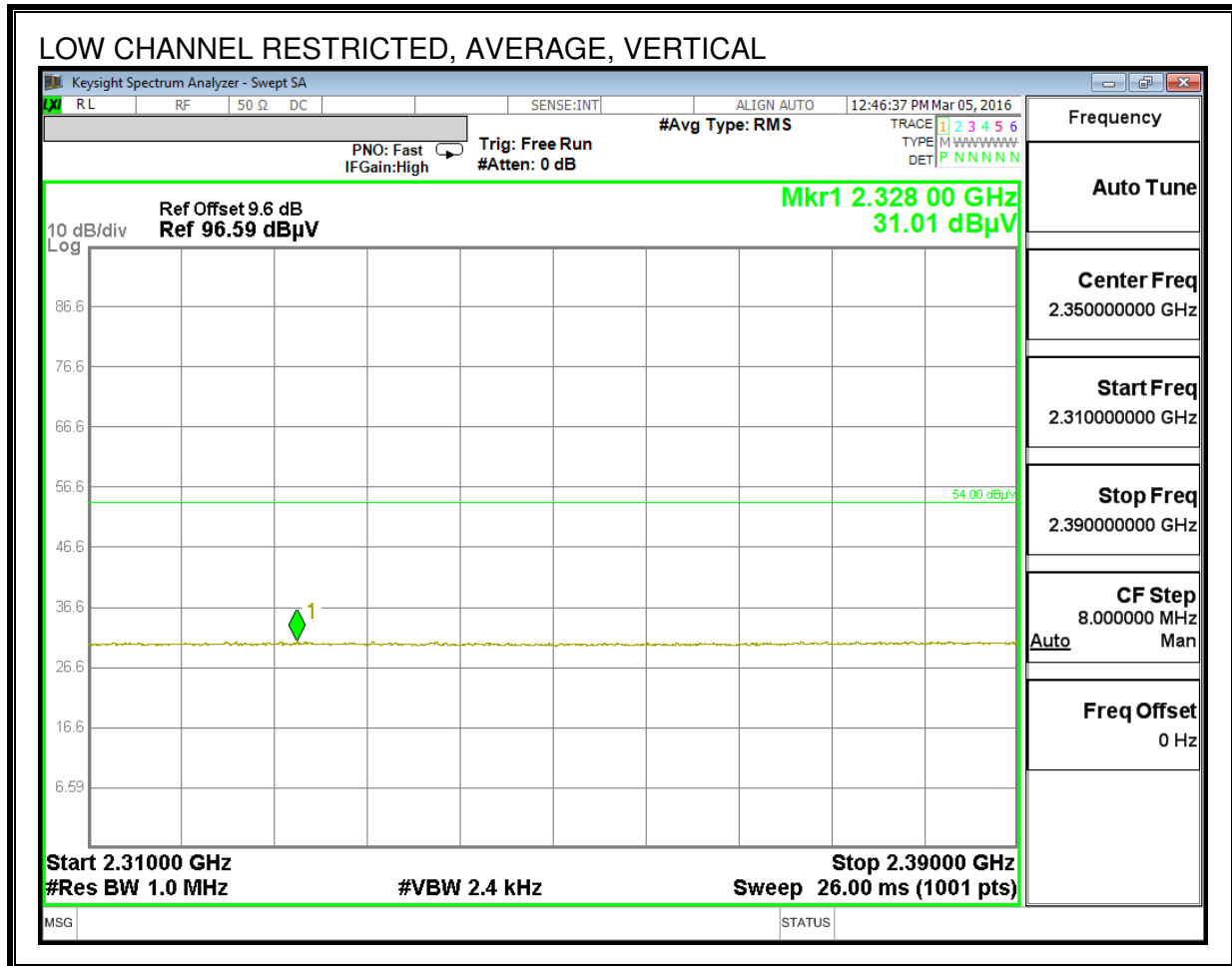

RESTRICTED BANDEDGE (HIGH CHANNEL)

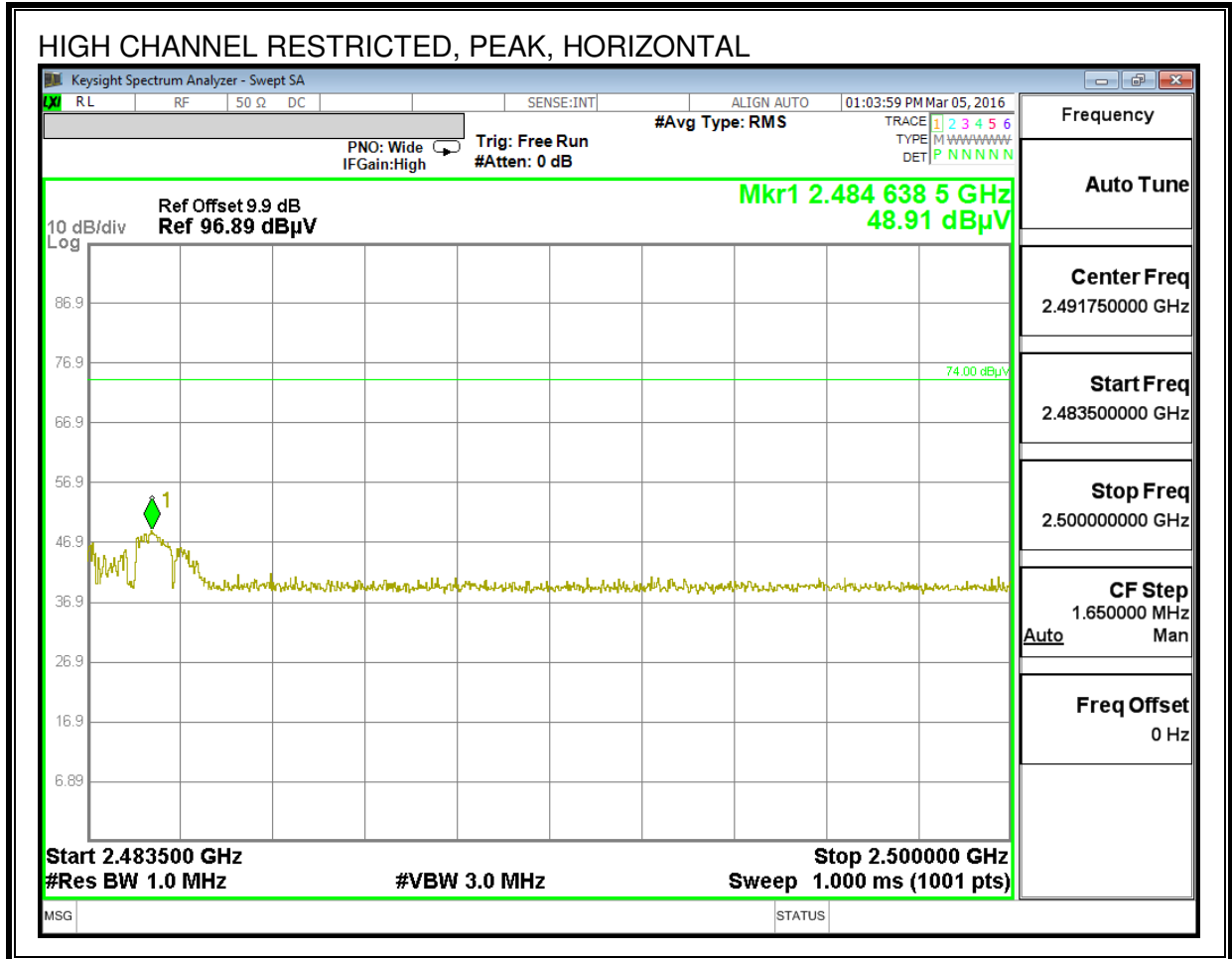

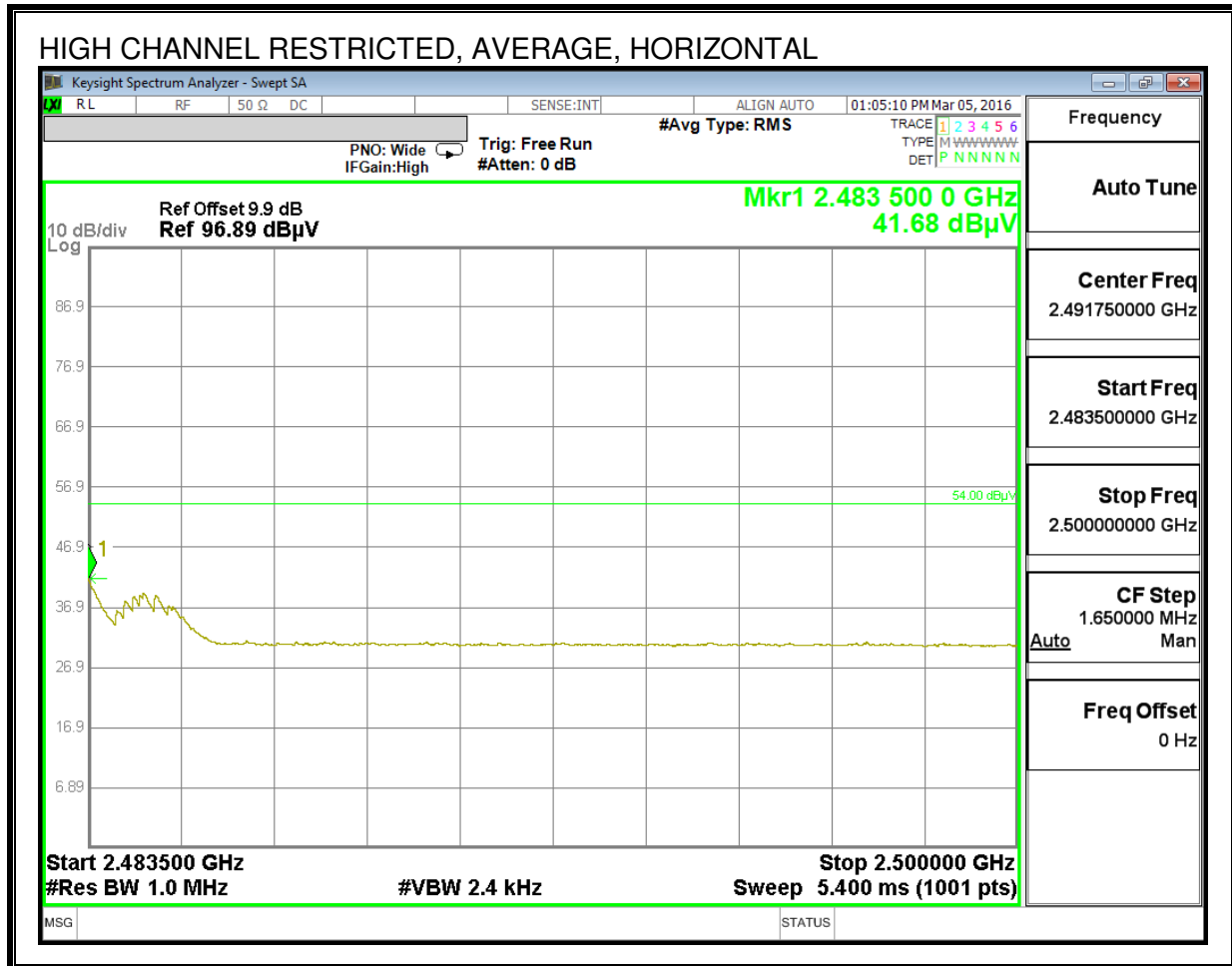

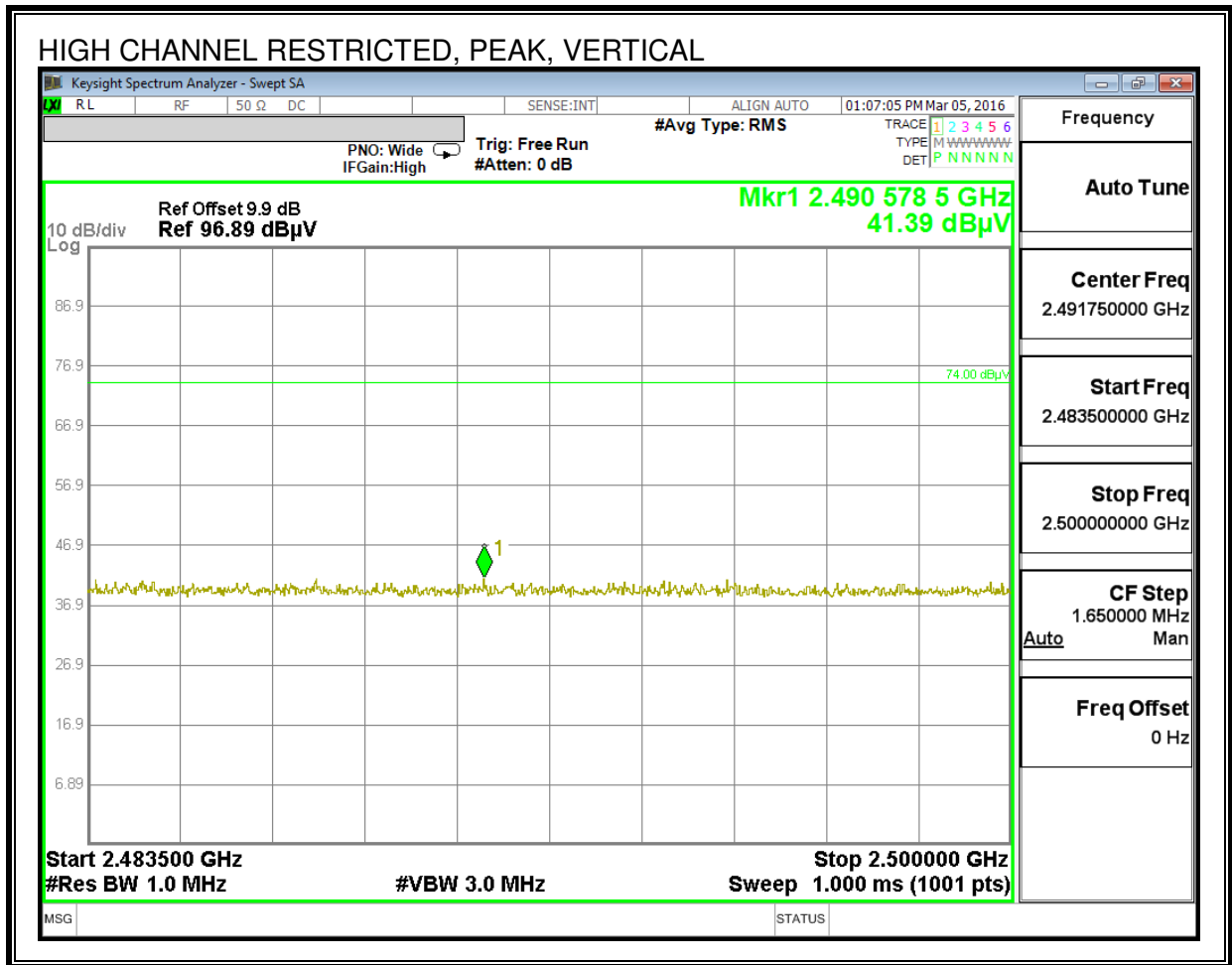

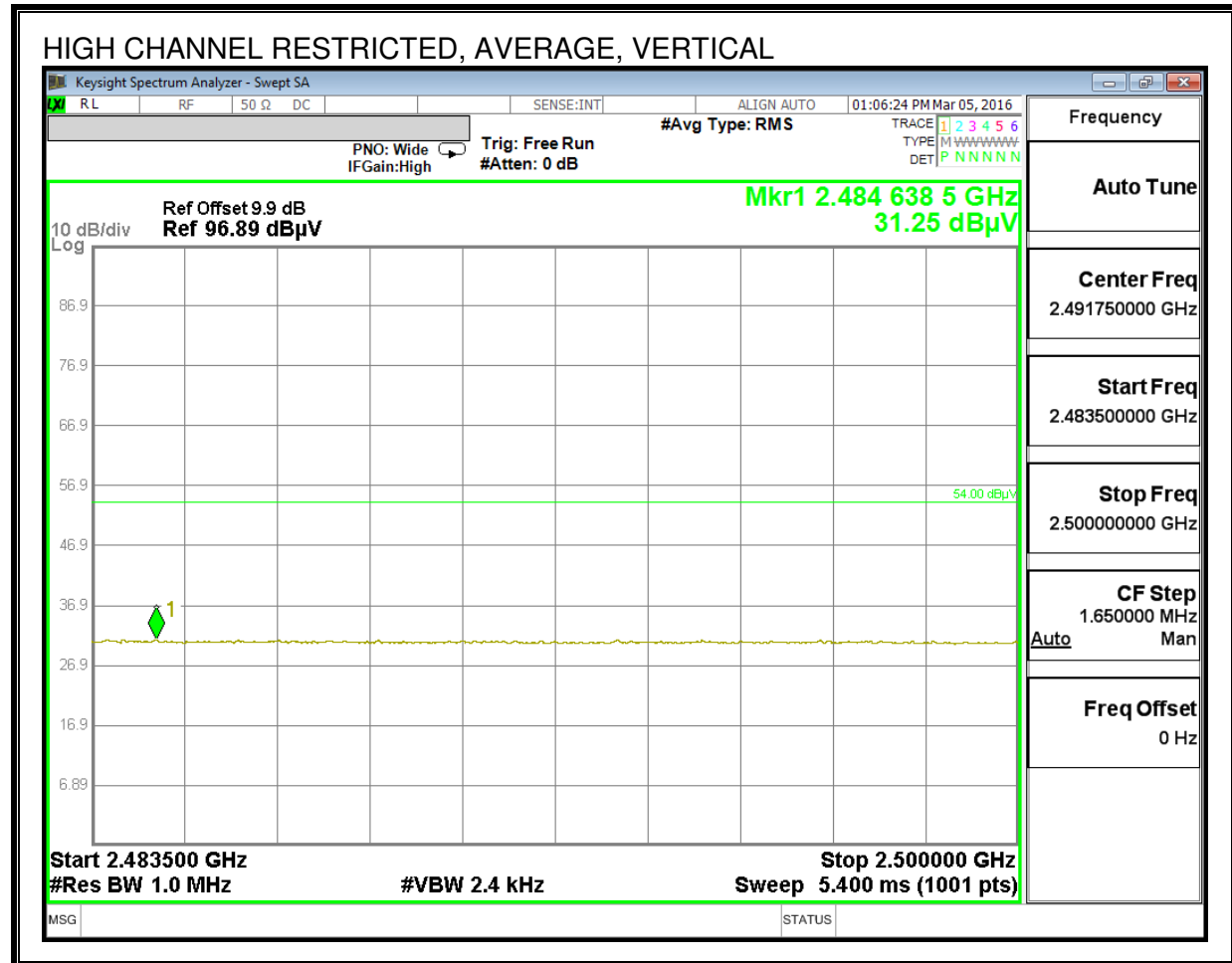

HARMONICS AND SPURIOUS EMISSIONS

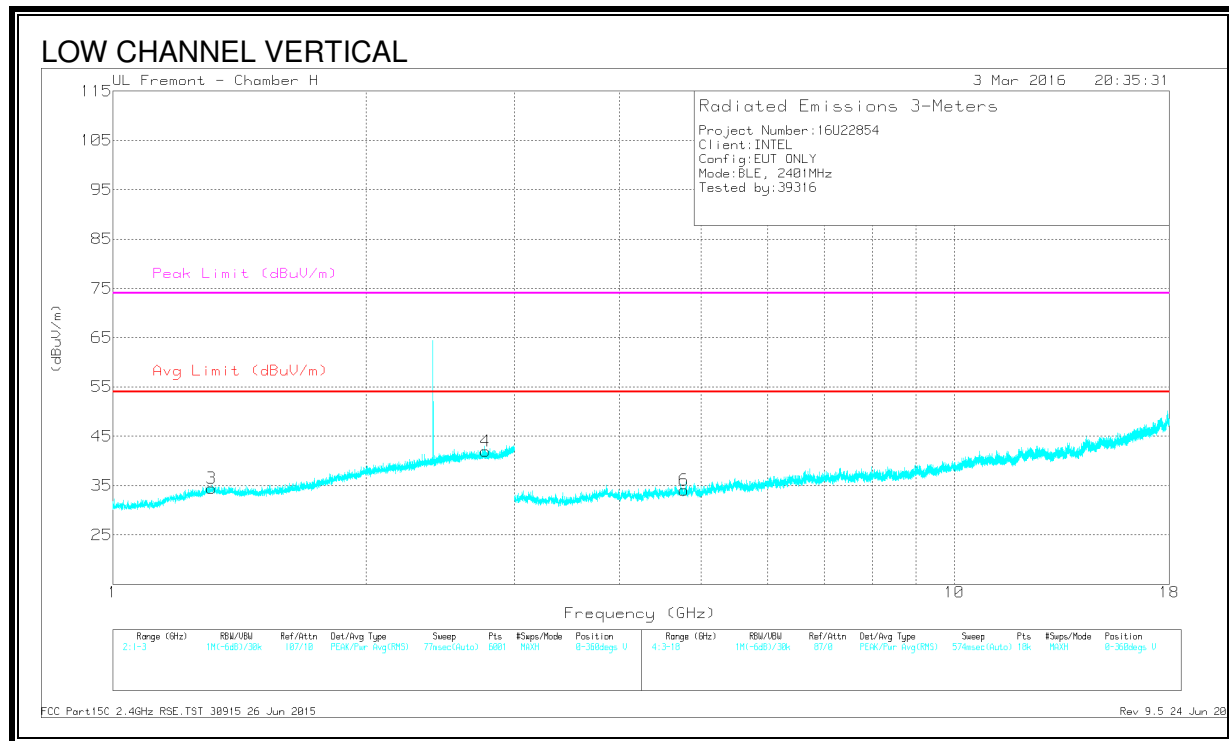
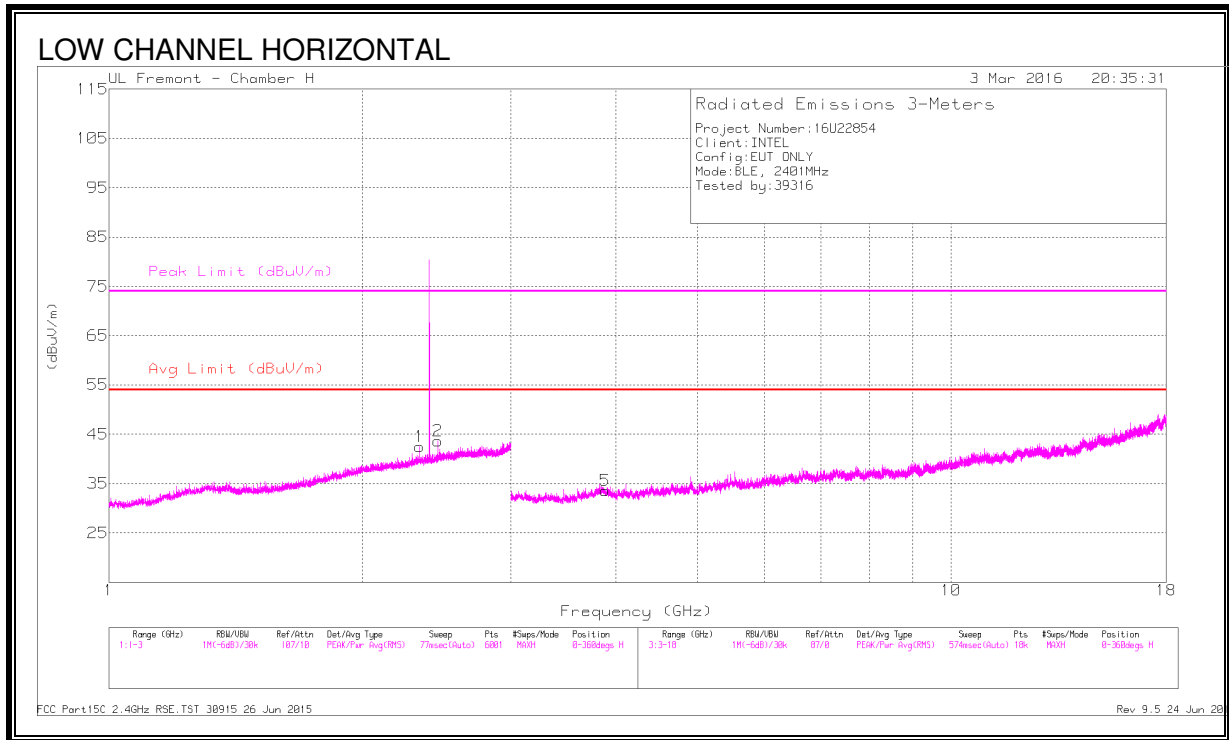

DATA

Marker	Frequency (GHz)	Meter Reading (dBuV)	Det	AFT863 (dB/m)	Amp/Cbl/Filtr/Pad (dB)	Corrected Reading (dBuV/m)	Avg Limit (dBuV/m)	Margin (dB)	Peak Limit (dBuV/m)	PK Margin (dB)	Azimuth (Degs)	Height (cm)	Polarity
1	* 2.338	38.21	PK2	31.9	-22.4	47.71	-	-	74	-26.29	151	211	H
	* 2.341	25.91	VA1T	31.9	-22.4	35.41	54	-18.59	-	-	151	211	H
2	* 1.309	36.84	PK2	28.9	-23	42.74	-	-	74	-31.26	227	213	V
	* 1.31	24.96	VA1T	28.9	-23	30.86	54	-23.14	-	-	227	213	V
3	* 2.771	38.06	PK2	32.4	-21.7	48.76	-	-	74	-25.24	221	253	V
	* 2.771	26.39	VA1T	32.4	-21.7	37.09	54	-16.91	-	-	221	253	V
4	* 3.882	39.35	PK2	33.6	-30.2	42.75	-	-	74	-31.25	221	253	H
	* 3.881	27.78	VA1T	33.6	-30.2	31.18	54	-22.82	-	-	221	253	H
6	* 4.776	38.56	PK2	34.2	-30.1	42.66	-	-	74	-31.34	221	253	V
	* 4.777	26.85	VA1T	34.2	-30.1	30.95	54	-23.05	-	-	221	253	V
2	2.458	33.89	Pk	32.3	-22.5	43.69	-	-	-	-	0-360	200	H

* - indicates frequency in CFR15.205/IC7.2.2 Restricted Band

PK - Peak detector

PK2 - KDB558074 Method: Maximum Peak

VA1T -: Linear Voltage Average $V_B=1/T_{on}$ where: T_{on} is transmit duration

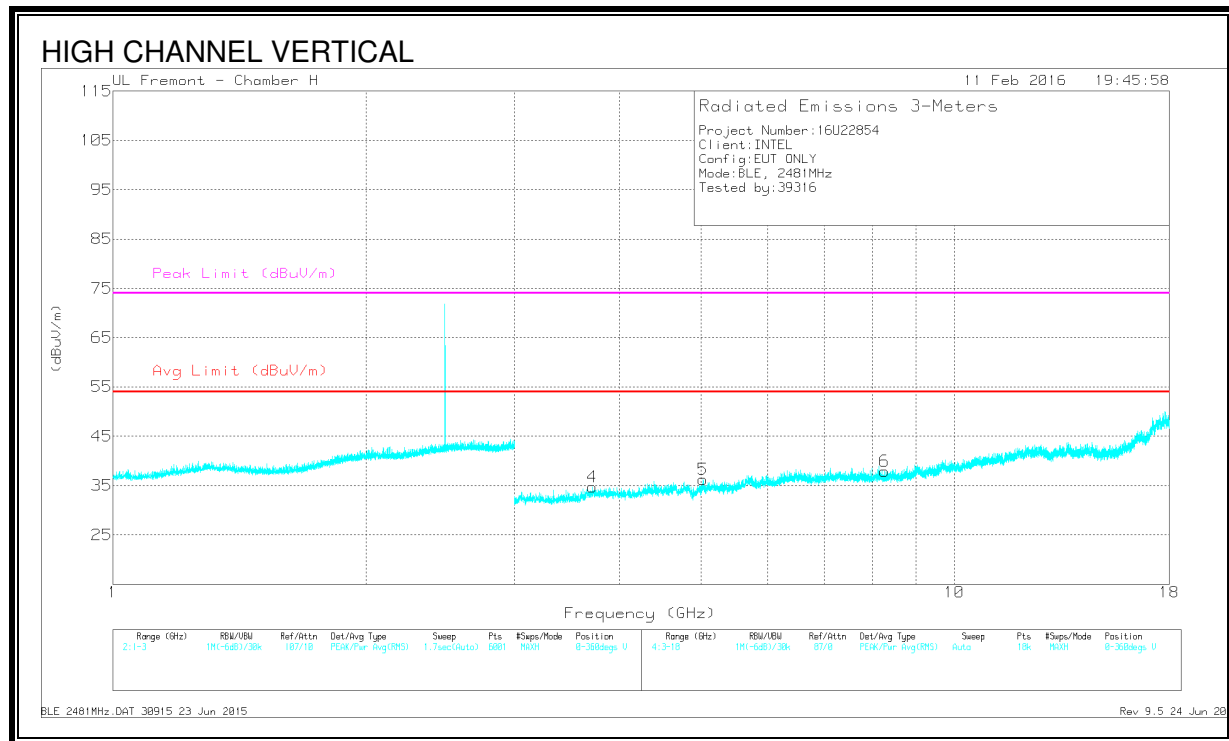
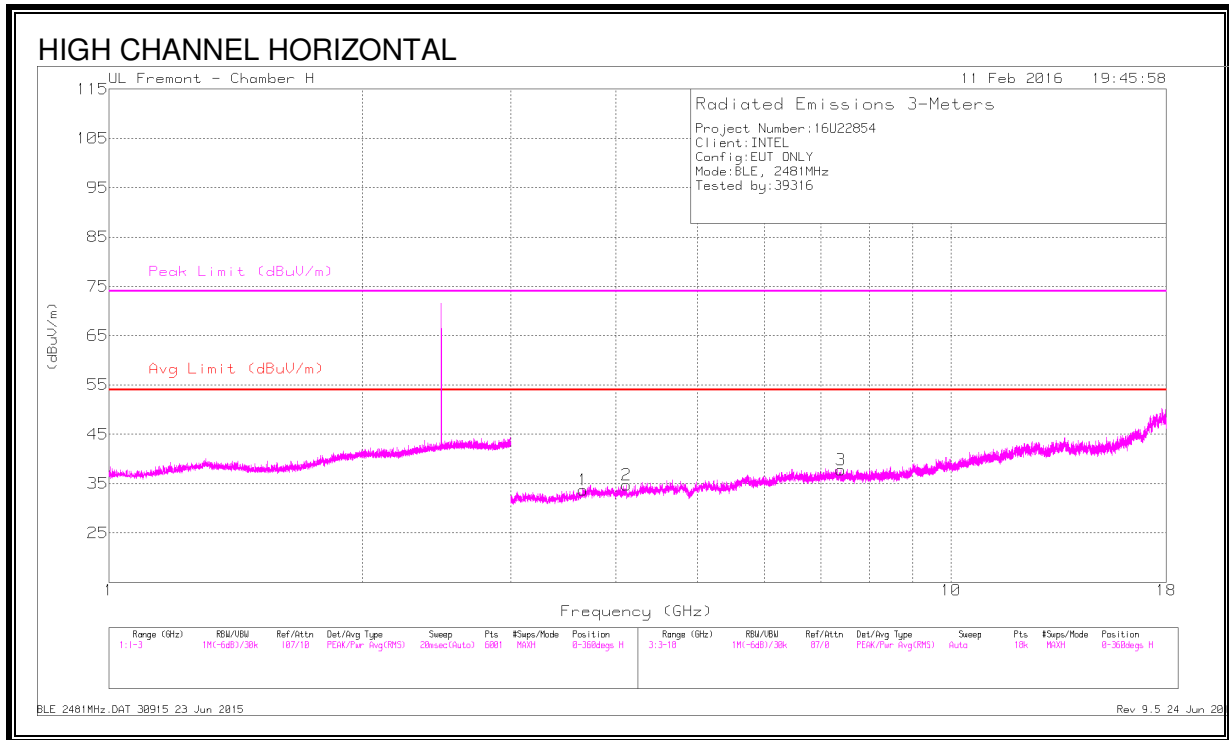

DATA

Marker	Frequency (GHz)	Meter Reading (dBuV)	Det	AF T862 (dB/m)	Amp/Cb/ Fitr/Pad (dB)	Corrected Reading (dBuV/m)	Avg Limit (dBuV/m)	Margin (dB)	Peak Limit (dBuV/m)	PK Margin (dB)	Azimuth (Degs)	Height (cm)	Polarity
1	* 3.657	39.8	PK2	33.1	-31.9	41	-	-	74	-33	44	235	H
	* 3.658	27.68	VA1T	33.1	-31.9	28.88	54	-25.12	-	-	44	235	H
2	* 4.118	38.72	PK2	33.3	-32.8	39.22	-	-	74	-34.78	44	235	H
	* 4.117	26.64	VA1T	33.3	-32.8	27.14	54	-26.86	-	-	44	235	H
3	* 7.394	37.06	PK2	35.6	-30.9	41.76	-	-	74	-32.24	44	235	H
	* 7.394	24.13	VA1T	35.6	-30.9	28.83	54	-25.17	-	-	44	235	H
4	* 3.714	39.24	PK2	33	-31.4	40.84	-	-	74	-33.16	44	235	V
	* 3.714	27.64	VA1T	33	-31.4	29.24	54	-24.76	-	-	44	235	V
5	* 5.03	39.66	PK2	34.2	-32.2	41.66	-	-	74	-32.34	44	235	V
	* 5.029	27.02	VA1T	34.2	-32.2	29.02	54	-24.98	-	-	44	235	V
6	* 8.256	37.16	PK2	35.7	-30.1	42.76	-	-	74	-31.24	44	235	V
	* 8.256	24.15	VA1T	35.7	-30	29.85	54	-24.15	-	-	44	235	V

* - indicates frequency in CFR15.205/IC7.2.2 Restricted Band

PK2 - KDB558074 Method: Maximum Peak

VA1T - FHSS: Linear Voltage Average VB=1/Ton where: Ton is transmit duration

8.3. WORST-CASE BELOW 1 GHz

SPURIOUS EMISSIONS 30 TO 1000 MHz (WORST-CASE CONFIGURATION, HORIZONTAL)

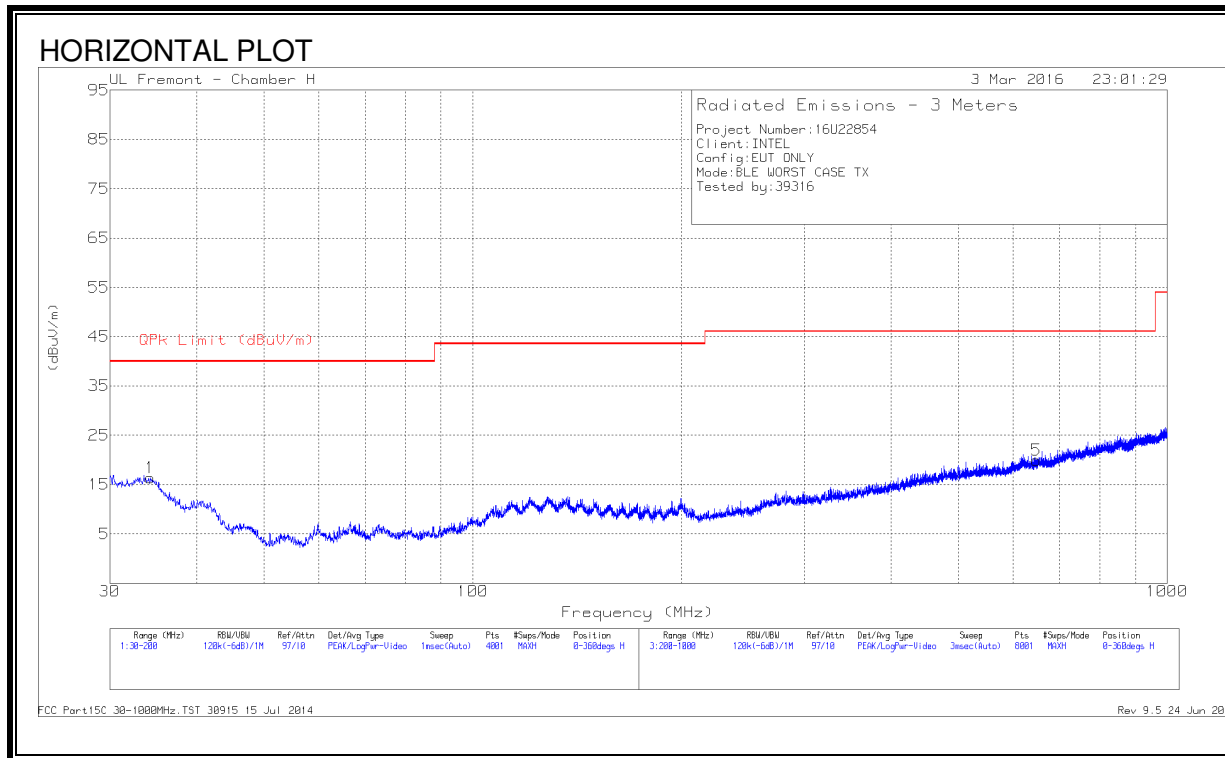

SPURIOUS EMISSIONS 30 TO 1000 MHz (WORST-CASE CONFIGURATION, VERTICAL)

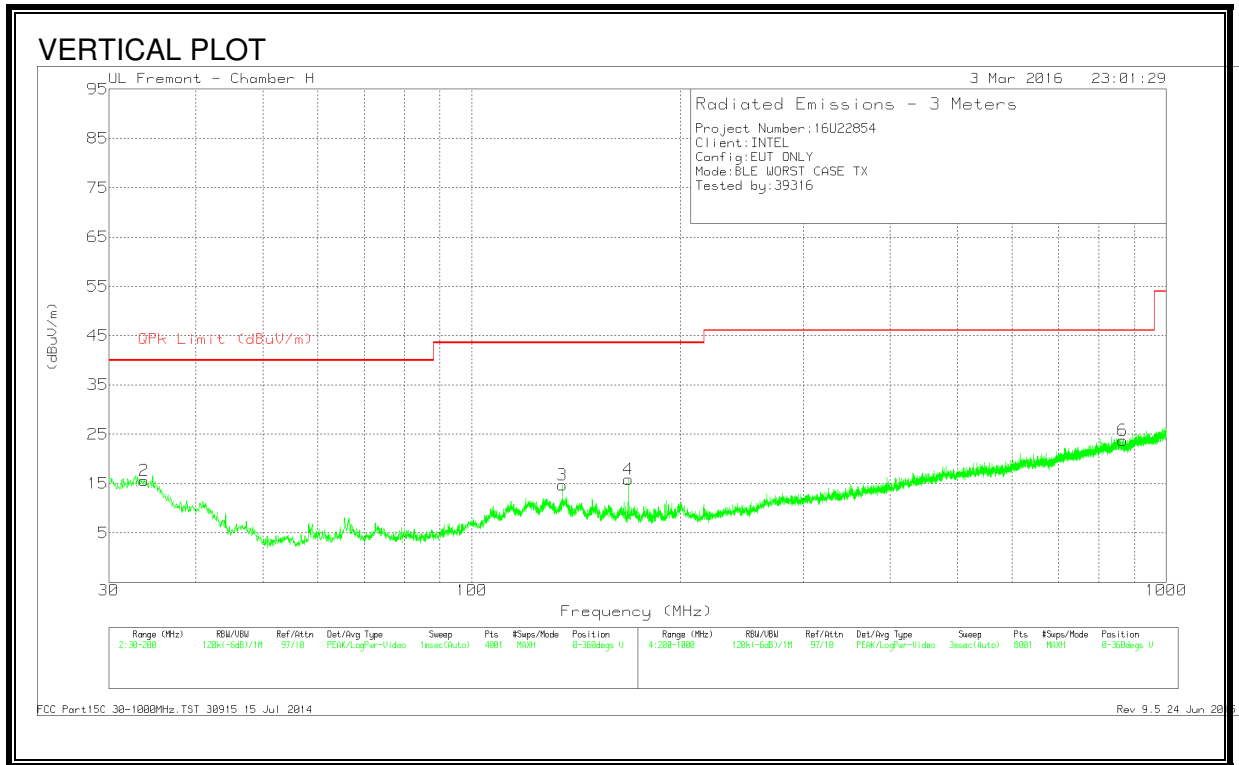

DATA

Marker	Frequency (MHz)	Meter Reading (dBuV)	Det	AF T900 (dB/m)	Amp/Cbl (dB)	Corrected Reading (dBuV/m)	QPk Limit (dBuV/m)	Margin (dB)	Azimuth (Degs)	Height (cm)	Polarity
3	* 134.975	31.36	Pk	13.6	-30.2	14.76	43.52	-28.76	0-360	100	V
4	* 167.9975	33.96	Pk	11.8	-29.9	15.86	43.52	-27.66	0-360	100	V
2	33.74	27.77	Pk	19.1	-31.3	15.57	40	-24.43	0-360	100	V
1	34.335	28.94	Pk	18.7	-31.2	16.44	40	-23.56	0-360	401	H
5	647.7	28.51	Pk	19.3	-27.8	20.01	46.02	-26.01	0-360	301	H
6	865.8	28.72	Pk	21.8	-26.8	23.72	46.02	-22.3	0-360	301	V

* - indicates frequency in CFR15.205/IC7.2.2 Restricted Band

Pk - Peak detector

8.4. WORST-CASE 18 – 26 GHz

SPURIOUS EMISSIONS 18 -26GHz (WORST-CASE CONFIGURATION)

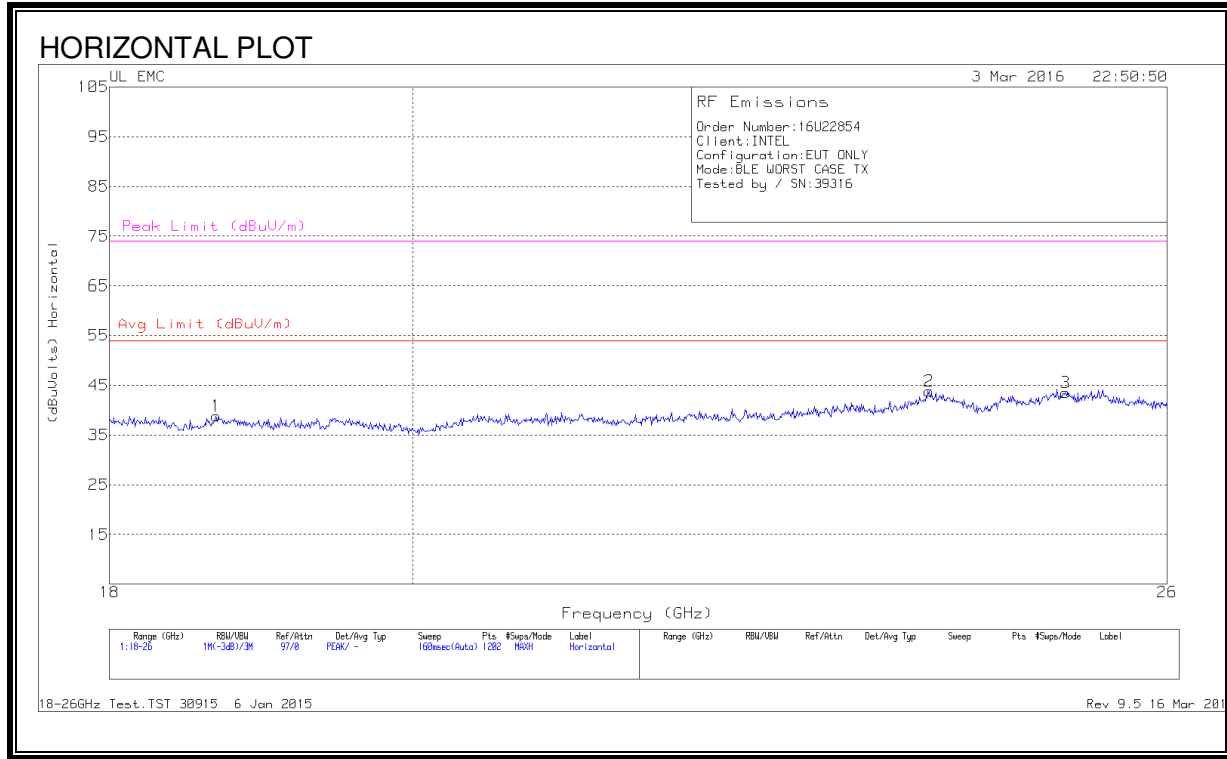

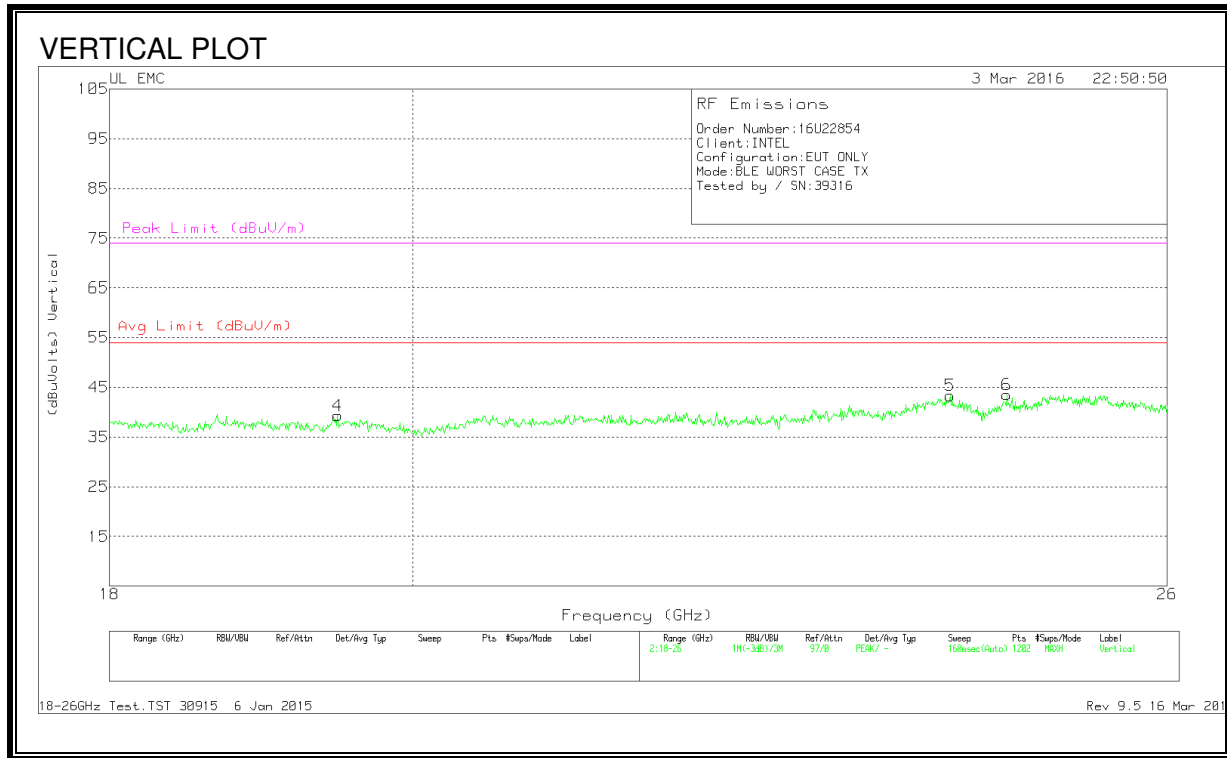

DATA

Marker	Frequency (GHz)	Meter Reading (dBuV)	Det	T477 AF (dB/m)	Amp/Cbl (dB)	Dist Corr (dB)	Corrected Reading (dBuVolts)	Avg Limit (dBuV/m)	Margin (dB)	Peak Limit (dBuV/m)	PK Margin (dB)
1	18.679	40.63	Pk	32.3	-24.6	-9.5	38.83	54	-15.16	74	-35.16
2	23.935	43.73	Pk	33.7	-24.1	-9.5	43.83	54	-10.16	74	-30.16
3	25.097	43.2	Pk	34.2	-24.4	-9.5	43.5	54	-10.5	74	-30.5
4	19.485	41.23	Pk	32.6	-25	-9.5	39.33	54	-14.66	74	-34.66
5	24.108	43.53	Pk	33.7	-24.4	-9.5	43.33	54	-10.66	74	-30.66
6	24.588	43.2	Pk	33.9	-24.1	-9.5	43.5	54	-10.5	74	-30.5

Pk - Peak detector

8.5. AC POWER LINE CONDUCTED EMISSIONS

LIMITS

FCC §15.207 (a)

RSS-Gen 8.8

Frequency of Emission (MHz)	Conducted Limit (dB μ V)	
	Quasi-peak	Average
0.15-0.5	66 to 56 *	56 to 46 *
0.5-5	56	46
5-30	60	50

*Decreases with the logarithm of the frequency.

TEST PROCEDURE

The EUT is placed on a non-conducting table 40 cm from the vertical ground plane and 80 cm above the horizontal ground plane. The EUT is configured in accordance with ANSI C63.10-2013

The receiver is set to a resolution bandwidth of 9 kHz. Peak detection is used unless otherwise noted as quasi-peak or average.

Line conducted data is recorded for both NEUTRAL and HOT lines

RESULTS

LOW CHANNEL – EUT ONLY

LINE 1 RESULTS

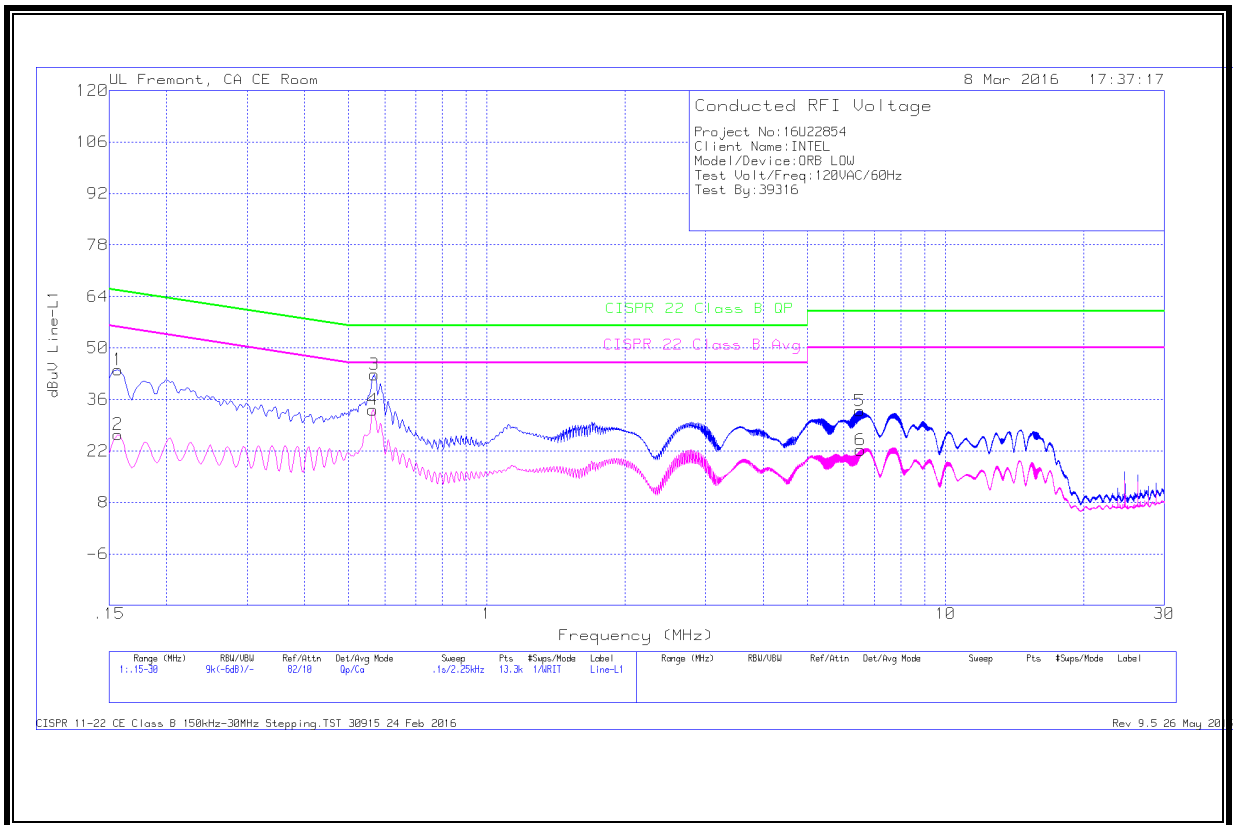

DATA

Range 1: Line-L1 .15 - 30MHz

Marker	Frequency (MHz)	Meter Reading (dBuV)	Det	T1310 IL L1	LC Cables 1&3	Limiter (dB)	Corrected Reading dBuV	CISPR 22 Class B QP	Margin (dB)	CISPR 22 Class B Avg	Margin (dB)
1	.15675	33.97	Qp	0	0	10.1	44.07	65.63	-21.56	-	-
2	.15675	16.35	Ca	0	0	10.1	26.45	-	-	55.63	-29.18
3	.5685	32.66	Qp	0	0	10.1	42.76	56	-13.24	-	-
4	.564	23.09	Ca	0	0	10.1	33.19	-	-	46	-12.81
5	6.50175	22.56	Qp	0	.1	10.2	32.86	60	-27.14	-	-
6	6.52425	11.93	Ca	0	.1	10.2	22.23	-	-	50	-27.77

Qp - Quasi-Peak detector

Ca - CISPR average detection

LINE 2 RESULTS

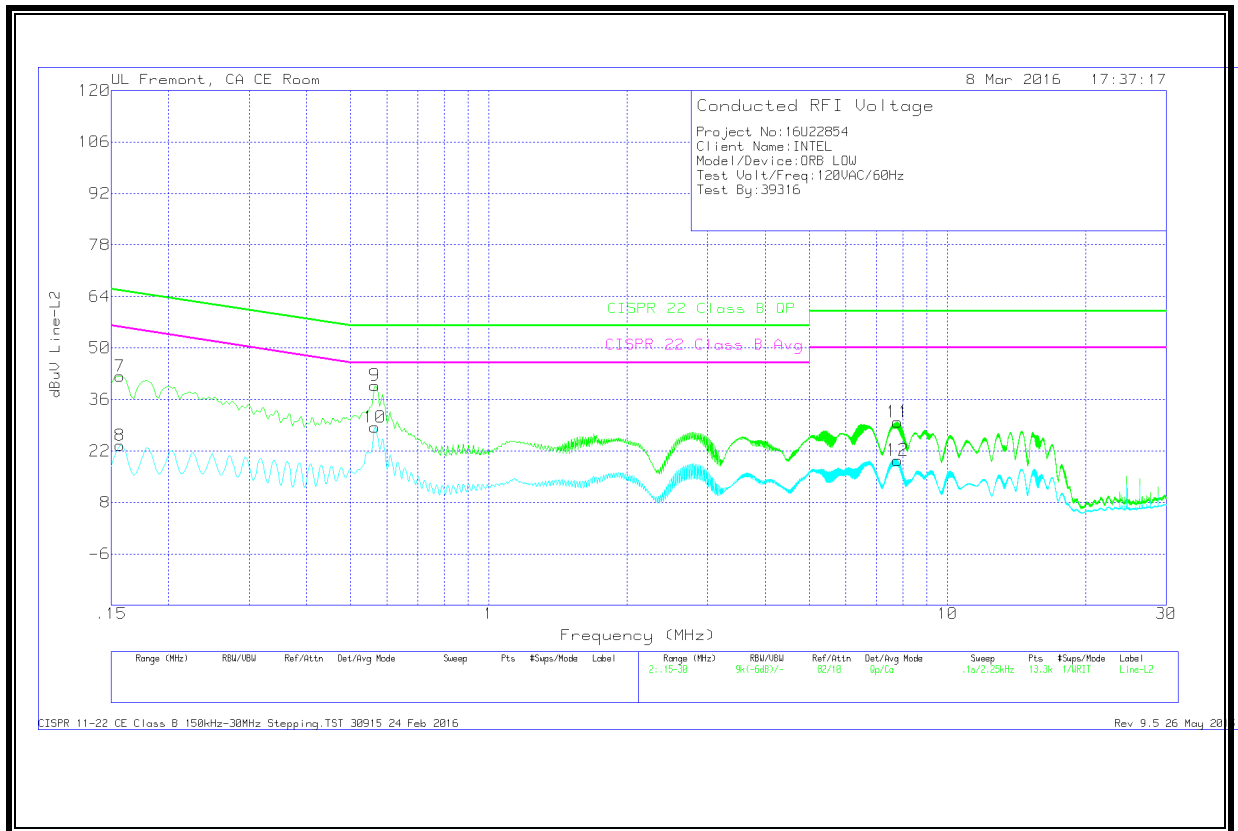

DATA

Range 2: Line-L2 .15 - 30MHz

Marker	Frequency (MHz)	Meter Reading (dBuV)	Det	T1310 IL L2	LC Cables 2&3	Limiter (dB)	Corrected Reading dBuV	CISPR 22 Class B QP	Margin (dB)	CISPR 22 Class B Avg	Margin (dB)
7	.15675	32.21	Qp	0	0	10.1	42.31	65.63	-23.32	-	-
8	.15675	13.38	Ca	0	0	10.1	23.48	-	-	55.63	-32.15
9	.564	29.7	Qp	0	0	10.1	39.8	56	-16.2	-	-
10	.564	18.36	Ca	0	0	10.1	28.46	-	-	46	-17.54
11	7.78425	19.55	Qp	0	.1	10.2	29.85	60	-30.15	-	-
12	7.78425	9.14	Ca	0	.1	10.2	19.44	-	-	50	-30.56

Qp - Quasi-Peak detector

HIGH CHANNEL – EUT ONLY

LINE 1 RESULTS

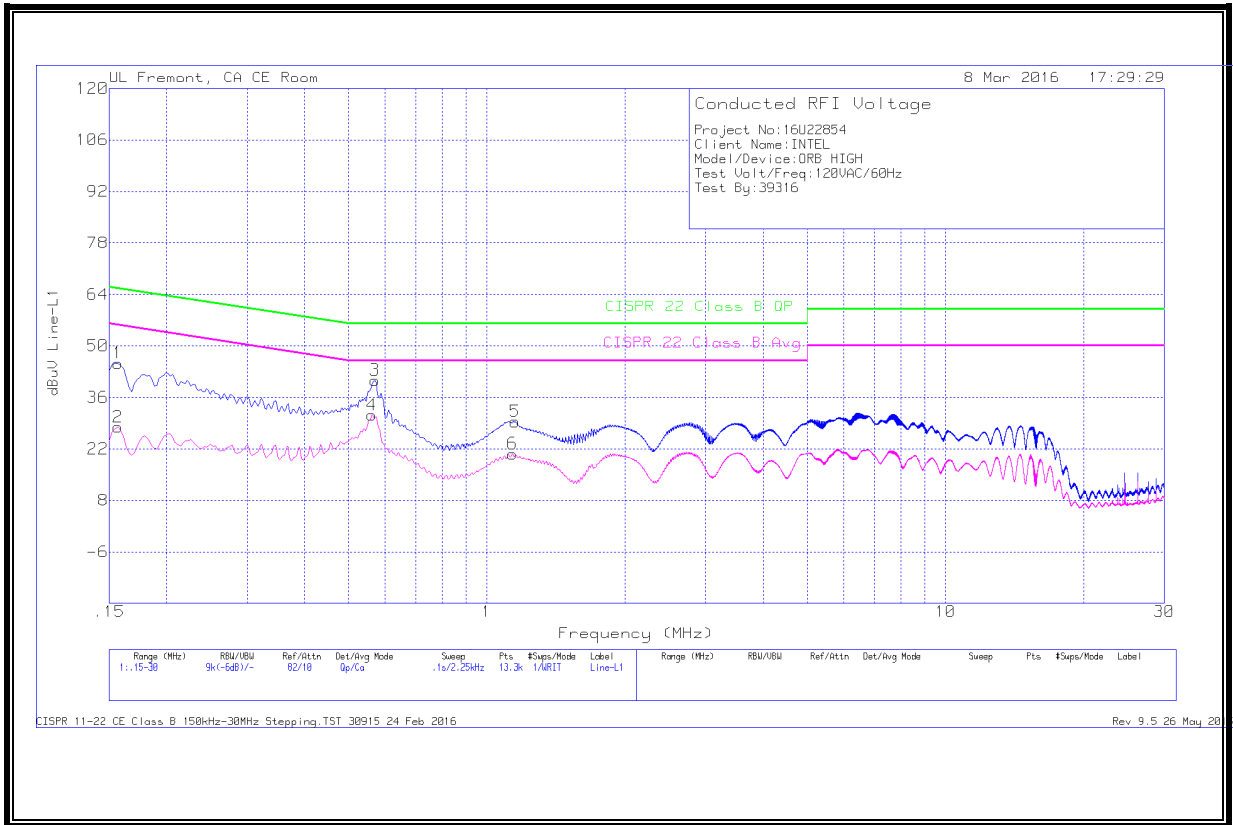

DATA

Range 1: Line-L1 .15 - 30MHz

Marker	Frequency (MHz)	Meter Reading (dBuV)	Det	T1310 IL L1	LC Cables 1&3	Limiter (dB)	Corrected Reading dBuV	CISPR 22 Class B QP	Margin (dB)	CISPR 22 Class B Avg	Margin (dB)
1	.15675	35.2	Qp	0	0	10.1	45.3	65.63	-20.33	-	-
2	.15675	17.84	Ca	0	0	10.1	27.94	-	-	55.63	-27.69
3	.57075	30.57	Qp	0	0	10.1	40.67	56	-15.33	-	-
4	.56175	21.05	Ca	0	0	10.1	31.15	-	-	46	-14.85
5	1.15125	19.31	Qp	0	0	10.1	29.41	56	-26.59	-	-
6	1.13775	10.56	Ca	0	0	10.1	20.66	-	-	46	-25.34

Qp - Quasi-Peak detector

Ca - CISPR average detection

LINE 2 RESULTS

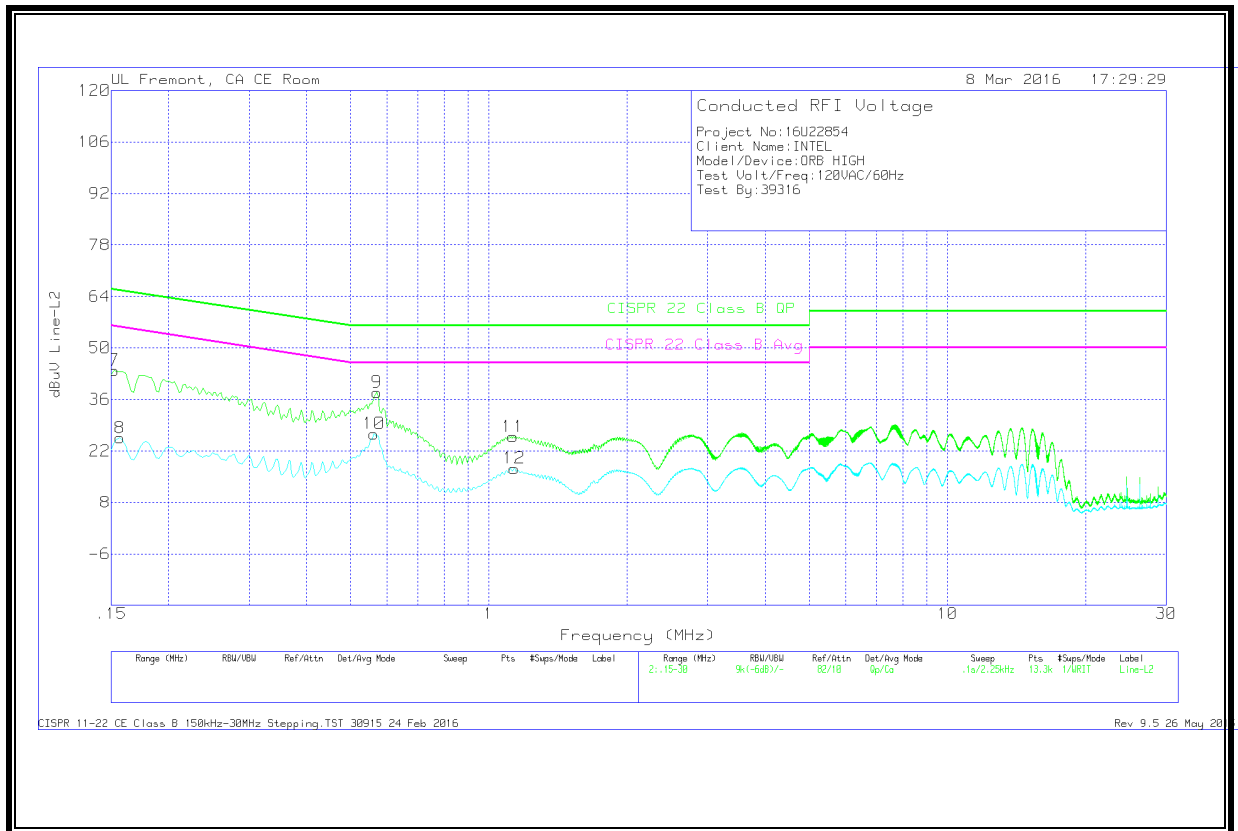

DATA

Range 2: Line-L2 .15 - 30MHz

Marker	Frequency (MHz)	Meter Reading (dBuV)	Det	T1310 IL L2	LC Cables 2&3	Limiter (dB)	Corrected Reading dBuV	CISPR 22 Class B QP	Margin (dB)	CISPR 22 Class B Avg	Margin (dB)
7	.15225	33.81	Qp	0	0	10.1	43.91	65.88	-21.97	-	-
8	.15675	15.46	Ca	0	0	10.1	25.56	-	-	55.63	-30.07
9	.57075	27.82	Qp	0	0	10.1	37.92	56	-18.08	-	-
10	.56175	16.55	Ca	0	0	10.1	26.65	-	-	46	-19.35
11	1.12875	15.69	Qp	0	.1	10.1	25.89	56	-30.11	-	-
12	1.1355	7.05	Ca	0	.1	10.1	17.25	-	-	46	-28.75

Qp - Quasi-Peak detector

Ca - CISPR average detection

LOW CHANNEL – EUT WITH LAPTOP

LINE 1 RESULTS

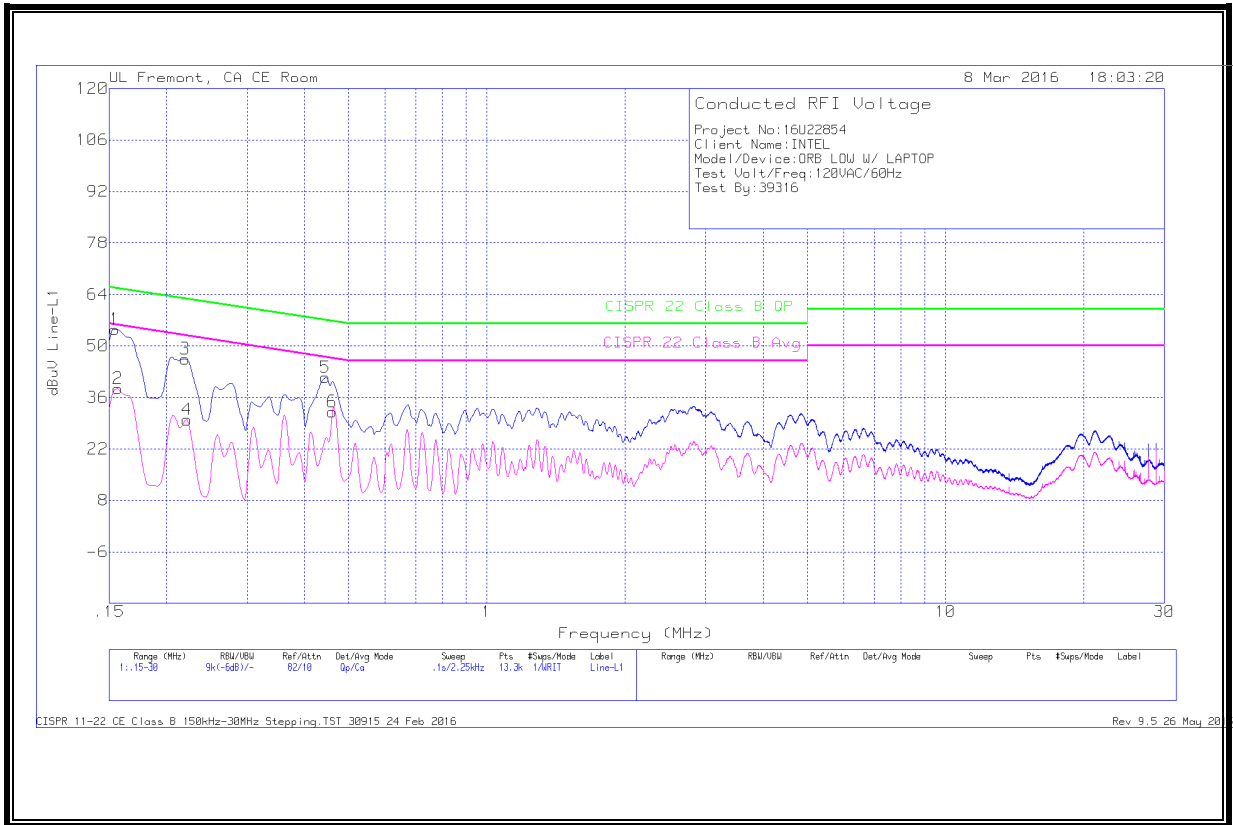

DATA

Range 1: Line-L1 .15 - 30MHz

Marker	Frequency (MHz)	Meter Reading (dBuV)	Det	T1310 IL L1	LC Cables 1&3	Limiter (dB)	Corrected Reading dBuV	CISPR 22 Class B QP	Margin (dB)	CISPR 22 Class B Avg	Margin (dB)
1	.1545	44.42	Qp	0	0	10.1	54.52	65.75	-11.23	-	-
2	.15675	28.3	Ca	0	0	10.1	38.4	-	-	55.63	-17.23
3	.21975	36.36	Qp	0	0	10.1	46.46	62.83	-16.37	-	-
4	.222	19.84	Ca	0	0	10.1	29.94	-	-	52.74	-22.8
5	.44475	31.31	Qp	0	0	10.1	41.41	56.97	-15.56	-	-
6	.4605	21.97	Ca	0	0	10.1	32.07	-	-	46.68	-14.61

Qp - Quasi-Peak detector

Ca - CISPR average detection

LINE 2 RESULTS

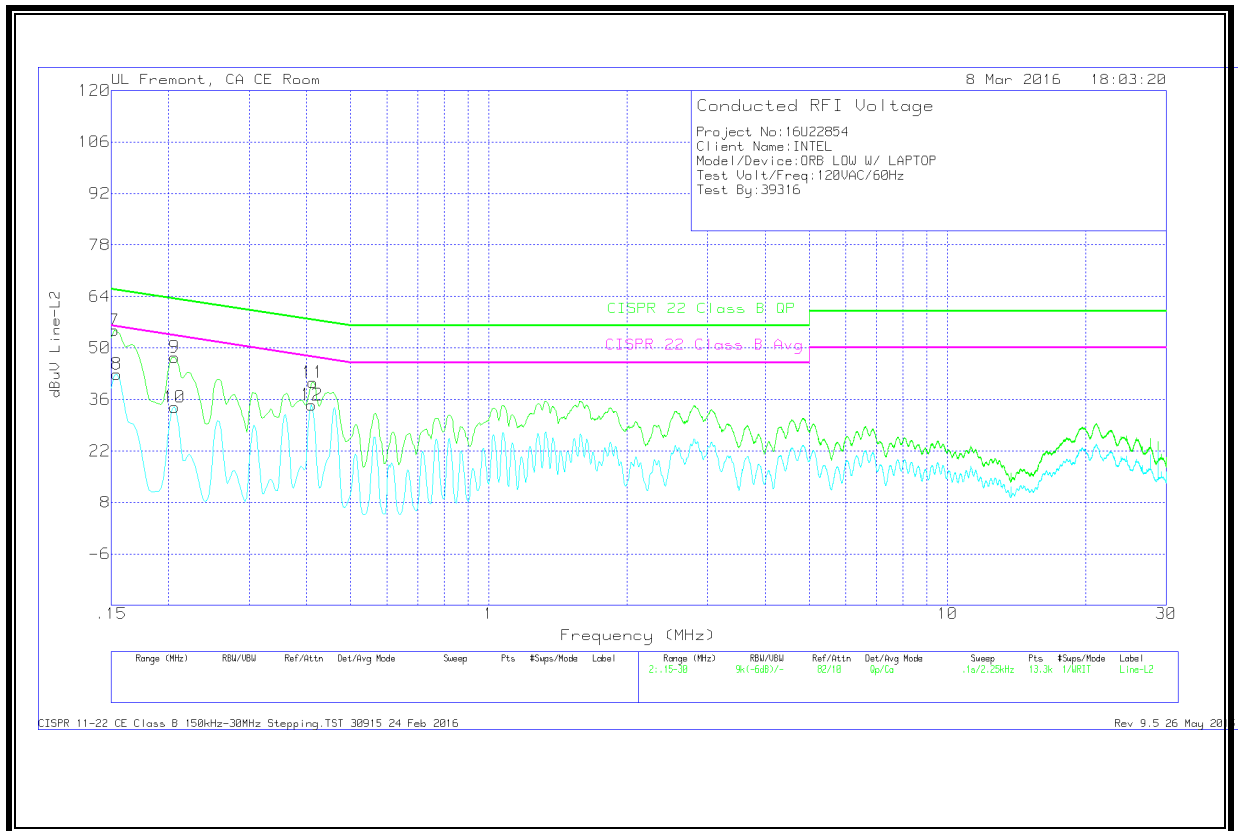

DATA

Range 2: Line-L2 .15 - 30MHz

Marker	Frequency (MHz)	Meter Reading (dBuV)	Det	T1310 IL L2	LC Cables 2&3	Limiter (dB)	Corrected Reading dBuV	CISPR 22 Class B QP	Margin (dB)	CISPR 22 Class B Avg	Margin (dB)
7	.15225	44.66	Qp	0	0	10.1	54.76	65.88	-11.12	-	-
8	.1545	32.78	Ca	0	0	10.1	42.88	-	-	55.75	-12.87
9	.20625	37.41	Qp	0	0	10.1	47.51	63.35	-15.84	-	-
10	.20625	23.78	Ca	0	0	10.1	33.88	-	-	53.35	-19.47
11	.41325	30.53	Qp	0	0	10.1	40.63	57.58	-16.95	-	-
12	.411	24.39	Ca	0	0	10.1	34.49	-	-	47.63	-13.14

Qp - Quasi-Peak detector

Ca - CISPR average detection

HIGH CHANNEL – EUT WITH LAPTOP

LINE 1 RESULTS

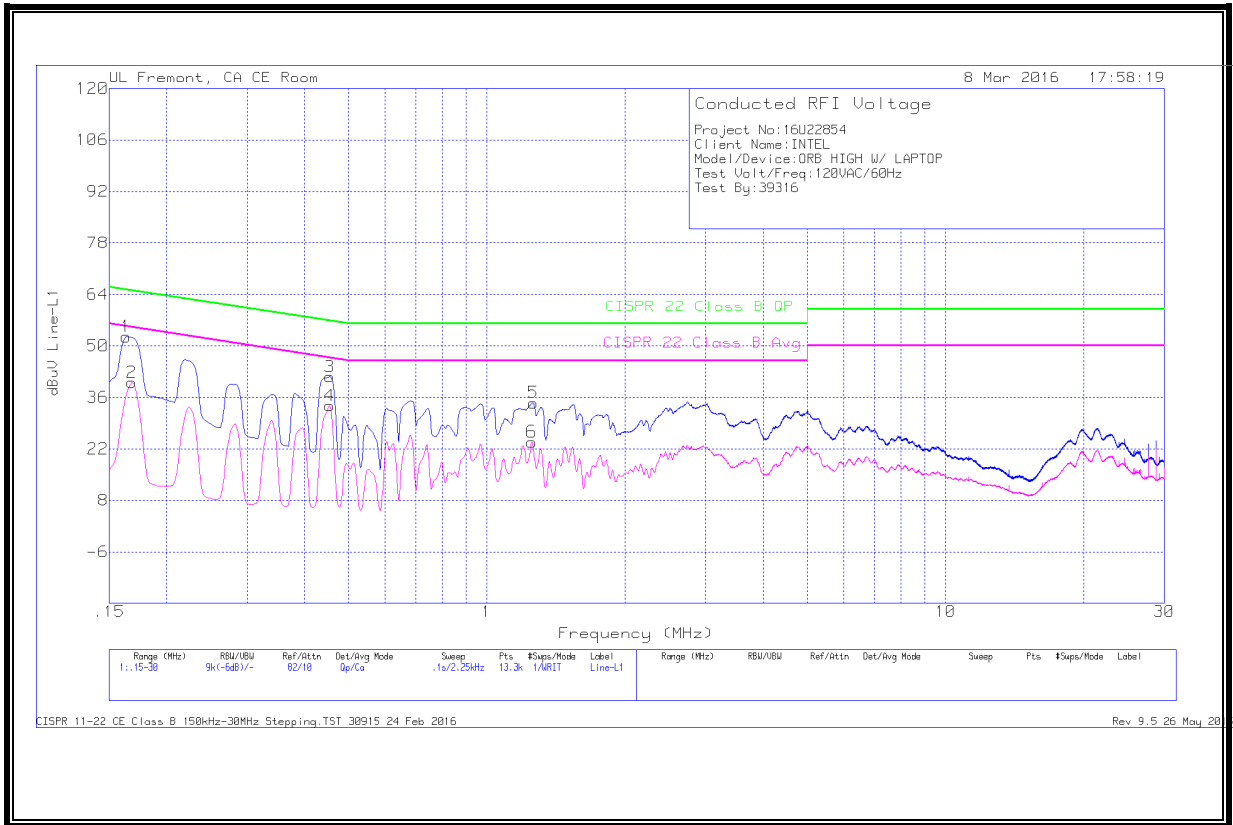

DATA

Range 1: Line-L1 .15 - 30MHz

Marker	Frequency (MHz)	Meter Reading (dBuV)	Det	T1310 IL L1	LC Cables 1&3	Limiter (dB)	Corrected Reading dBuV	CISPR 22 Class B QP	Margin (dB)	CISPR 22 Class B Avg	Margin (dB)
1	.1635	42.41	Qp	0	0	10.1	52.51	65.28	-12.77	-	-
2	.168	30	Ca	0	0	10.1	40.1	-	-	55.06	-14.96
3	.45375	31.51	Qp	0	0	10.1	41.61	56.81	-15.2	-	-
4	.45375	23.63	Ca	0	0	10.1	33.73	-	-	46.81	-13.08
5	1.2615	24.32	Qp	0	.1	10.1	34.52	56	-21.48	-	-
6	1.2525	13.78	Ca	0	0	10.1	23.88	-	-	46	-22.12

Qp - Quasi-Peak detector

Ca - CISPR average detection

LINE 2 RESULTS

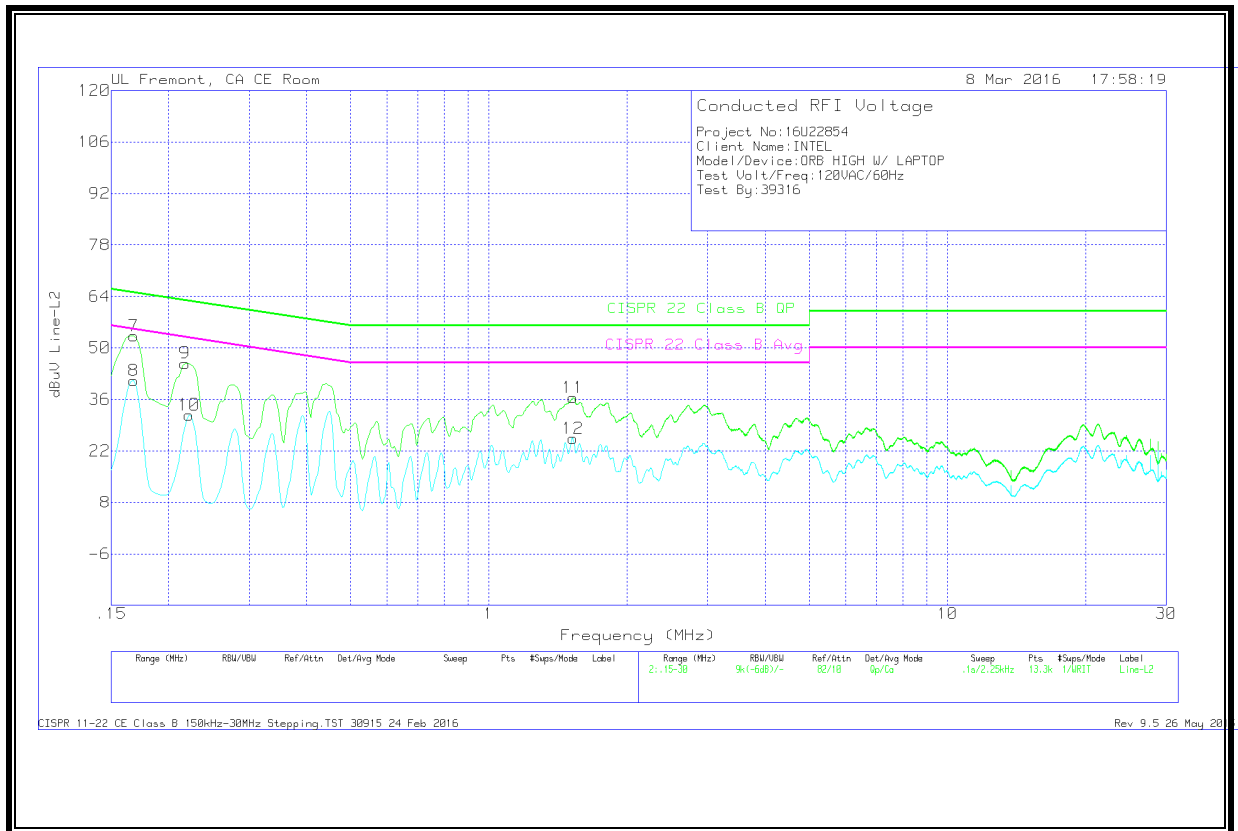

DATA

Range 2: Line-L2 .15 - 30MHz

Marker	Frequency (MHz)	Meter Reading (dBuV)	Det	T1310 IL L2	LC Cables 2&3	Limiter (dB)	Corrected Reading dBuV	CISPR 22 Class B QP	Margin (dB)	CISPR 22 Class B Avg	Margin (dB)
7	.168	43.12	Qp	0	0	10.1	53.22	65.06	-11.84	-	-
8	.168	30.97	Ca	0	0	10.1	41.07	-	-	55.06	-13.99
9	.2175	35.71	Qp	0	0	10.1	45.81	62.91	-17.1	-	-
10	.222	21.63	Ca	0	0	10.1	31.73	-	-	52.74	-21.01
11	1.527	26.28	Qp	0	.1	10.1	36.48	56	-19.52	-	-
12	1.52475	15.15	Ca	0	.1	10.1	25.35	-	-	46	-20.65

Qp - Quasi-Peak detector

Ca - CISPR average detection