



**FCC 47 CFR PART 15 SUBPART C  
INDUSTRY CANADA RSS-247 ISSUE 1**

**BLUETOOTH LOW ENERGY  
CERTIFICATION TEST REPORT**

**FOR**

**BLE MODULE**

**MODEL NUMBER: ORB**

**FCC ID: 2AB8ZND14  
IC: 1000X-ND14**

**REPORT NUMBER: 15U22570-E1V1**

**ISSUE DATE: JANUARY 27, 2016**

*Prepared for*  
**INTEL CORPORATION  
2200 MISSION COLLEGE BOULEVARD,  
SANTA CLARA, CA 95052, U.S.A**

*Prepared by*  
**UL VERIFICATION SERVICES INC.  
47173 BENICIA STREET  
FREMONT, CA 94538, U.S.A.  
TEL: (510) 771-1000  
FAX: (510) 661-0888**



**NVLAP LAB CODE 200065-0**

Revision History

<u>Rev.</u>	<u>Issue Date</u>	<u>Revisions</u>	<u>Revised By</u>
V1	01/27/2016	Initial Issue	C. Xiong

## TABLE OF CONTENTS

<b>1. ATTESTATION OF TEST RESULTS .....</b>	<b>4</b>
<b>2. TEST METHODOLOGY .....</b>	<b>5</b>
<b>3. FACILITIES AND ACCREDITATION .....</b>	<b>5</b>
<b>4. CALIBRATION AND UNCERTAINTY .....</b>	<b>6</b>
4.1. <i>MEASURING INSTRUMENT CALIBRATION .....</i>	<i>6</i>
4.2. <i>SAMPLE CALCULATION .....</i>	<i>6</i>
4.3. <i>MEASUREMENT UNCERTAINTY.....</i>	<i>6</i>
<b>5. EQUIPMENT UNDER TEST .....</b>	<b>7</b>
5.1. <i>DESCRIPTION OF EUT .....</i>	<i>7</i>
5.2. <i>MAXIMUM OUTPUT POWER.....</i>	<i>7</i>
5.3. <i>DESCRIPTION OF AVAILABLE ANTENNAS .....</i>	<i>7</i>
5.4. <i>SOFTWARE AND FIRMWARE.....</i>	<i>7</i>
5.5. <i>WORST-CASE CONFIGURATION AND MODE.....</i>	<i>7</i>
5.6. <i>DESCRIPTION OF TEST SETUP.....</i>	<i>8</i>
<b>6. TEST AND MEASUREMENT EQUIPMENT .....</b>	<b>12</b>
<b>7. ANTENNA PORT TEST RESULTS .....</b>	<b>13</b>
7.1. <i>MEASUREMENT METHODS .....</i>	<i>13</i>
7.2. <i>ON TIME, DUTY CYCLE .....</i>	<i>14</i>
7.3. <i>6 dB BANDWIDTH.....</i>	<i>15</i>
7.4. <i>99% BANDWIDTH.....</i>	<i>18</i>
7.5. <i>OUTPUT POWER.....</i>	<i>21</i>
7.6. <i>AVERAGE POWER.....</i>	<i>24</i>
7.7. <i>POWER SPECTRAL DENSITY .....</i>	<i>25</i>
7.8. <i>CONDUCTED SPURIOUS EMISSIONS.....</i>	<i>28</i>
<b>8. RADIATED TEST RESULTS.....</b>	<b>32</b>
8.1. <i>LIMITS AND PROCEDURE .....</i>	<i>32</i>
8.2. <i>TRANSMITTER ABOVE 1 GHz.....</i>	<i>33</i>
8.3. <i>WORST-CASE BELOW 1 GHz.....</i>	<i>43</i>
8.4. <i>WORST-CASE 18 – 26 GHz.....</i>	<i>45</i>
8.5. <i>AC POWER LINE CONDUCTED EMISSIONS .....</i>	<i>47</i>
<b>9. SETUP PHOTOS.....</b>	<b>52</b>

# 1. ATTESTATION OF TEST RESULTS

**COMPANY NAME:** INTEL CORPORATION  
2200 MISSION COLLEGE BOULEVARD  
SANTA CLARA, CA 95052, U.S.A.

**EUT DESCRIPTION:** BLE MODULE

**MODEL:** ORB

**SERIAL NUMBER:** 03-06(CONDUCTED); 06-75(RADIATED)

**DATE TESTED:** JANUARY 14- 23, 2016

APPLICABLE STANDARDS	
STANDARD	TEST RESULTS
CFR 47 Part 15 Subpart C	Pass
INDUSTRY CANADA RSS-247 Issue 1	Pass
INDUSTRY CANADA RSS-GEN Issue 4	Pass

UL Verification Services Inc. tested the above equipment in accordance with the requirements set forth in the above standards. All indications of Pass/Fail in this report are opinions expressed by UL Verification Services Inc. based on interpretations and/or observations of test results. Measurement Uncertainties were not taken into account and are published for informational purposes only. The test results show that the equipment tested is capable of demonstrating compliance with the requirements as documented in this report.

**Note:** The results documented in this report apply only to the tested sample, under the conditions and modes of operation as described herein. This document may not be altered or revised in any way unless done so by UL Verification Services Inc. and all revisions are duly noted in the revisions section. Any alteration of this document not carried out by UL Verification Services Inc. will constitute fraud and shall nullify the document. This report must not be used by the client to claim product certification, approval, or endorsement by NVLAP, NIST, any agency of the Federal Government, or any agency of any government.

Approved & Released For  
UL Verification Services Inc. By:

Tested By:

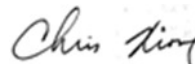

---

CHIN PANG  
EMC SENIOR ENGINEER  
UL VERIFICATION SERVICES INC.

---

CHRIS XIONG  
EMC ENGINEER  
UL VERIFICATION SERVICES INC.

## 2. TEST METHODOLOGY

The tests documented in this report were performed in accordance with FCC CFR 47 Part 2, FCC CFR 47 Part 15, ANSI C63.10-2013, RSS-GEN Issue 4 and RSS-247 Issue 1.

## 3. FACILITIES AND ACCREDITATION

The test sites and measurement facilities used to collect data are located at 47173 and 47266 Benicia Street, Fremont, California, USA. Line conducted emissions are measured only at the 47173 address. The following table identifies which facilities were utilized for radiated emission measurements documented in this report. Specific facilities are also identified in the test results sections.

47173 Benicia Street	47266 Benicia Street
<input type="checkbox"/> Chamber A	<input type="checkbox"/> Chamber D
<input type="checkbox"/> Chamber B	<input type="checkbox"/> Chamber E
<input type="checkbox"/> Chamber C	<input type="checkbox"/> Chamber F
	<input type="checkbox"/> Chamber G
	<input checked="" type="checkbox"/> Chamber H

The above test sites and facilities are covered under FCC Test Firm Registration # 208313. Chambers A through H are covered under Industry Canada company address code 2324B with site numbers 2324B -1 through 2324B-8, respectively.

UL Verification Services Inc. is accredited by NVLAP, Laboratory Code 200065-0. The full scope of accreditation can be viewed at <http://ts.nist.gov/standards/scopes/2000650.htm>.

## 4. CALIBRATION AND UNCERTAINTY

### 4.1. MEASURING INSTRUMENT CALIBRATION

The measuring equipment utilized to perform the tests documented in this report has been calibrated in accordance with the manufacturer's recommendations, and is traceable to recognized national standards.

### 4.2. SAMPLE CALCULATION

Where relevant, the following sample calculation is provided:

$$\begin{aligned} \text{Field Strength (dBuV/m)} &= \text{Measured Voltage (dBuV)} + \text{Antenna Factor (dB/m)} + \\ &\text{Cable Loss (dB)} - \text{Preamp Gain (dB)} \\ 36.5 \text{ dBuV} + 18.7 \text{ dB/m} + 0.6 \text{ dB} - 26.9 \text{ dB} &= 28.9 \text{ dBuV/m} \end{aligned}$$

### 4.3. MEASUREMENT UNCERTAINTY

Where relevant, the following measurement uncertainty levels have been estimated for tests performed on the apparatus:

PARAMETER	UNCERTAINTY
Conducted Disturbance, 0.15 to 30 MHz	± 3.52 dB
Radiated Disturbance, 30 to 1000 MHz	± 4.94 dB
Radiated Disturbance, 1 to 6 GHz	± 3.86 dB
Radiated Disturbance, 6 to 18 GHz	± 4.23 dB
Radiated Disturbance, 18 to 26 GHz	± 5.30 dB
Radiated Disturbance, 26 to 40 GHz	± 5.23 dB

Uncertainty figures are valid to a confidence level of 95%.

## 5. EQUIPMENT UNDER TEST

### 5.1. DESCRIPTION OF EUT

The EUT is a BLE module

### 5.2. MAXIMUM OUTPUT POWER

The transmitter has a maximum peak conducted output power as follows:

Frequency Range (MHz)	Mode	Output Power (dBm)	Output Power (mW)
2402 - 2480	BLE	1.75	1.50

### 5.3. DESCRIPTION OF AVAILABLE ANTENNAS

The radio utilizes a chip antenna, with a maximum gain of 1.7 dBi.

### 5.4. SOFTWARE AND FIRMWARE

The firmware installed in the EUT during testing was MFG.

### 5.5. WORST-CASE CONFIGURATION AND MODE

Radiated emission and power line conducted emission were performed with the EUT set to transmit at the channel with highest output power as worst-case scenario.

The fundamental of the EUT was investigated in three orthogonal orientations X, Y and Z, it was determined that Y orientation was worst-case orientation; therefore, all final radiated testing was performed with the EUT in Y orientation.

Worst-case data rates as provided by the client were:

BLE: 1 Mbps.

## 5.6. DESCRIPTION OF TEST SETUP

### SUPPORT EQUIPMENT

Support Equipment List				
Description	Manufacturer	Model	Serial Number	FCC ID
Laptop	Lenovo	Yoga 2 11	YB04282152	N/A
AC Adapter	Lenovo	ADLX45NDC3A	11S45N0289Z1ZS9K4	N/A
Test Board	Intel	Debug Ext Board H86	CRBSO071509053	N/A

### I/O CABLES

I/O Cable List					
Cable No	Port	# of identical ports	Connector Type	Cable Type	Cable Length (m)
1	AC	1	3-Prong	Un-Shielded	1.8
2	DC	1	DC	Un-Shielded	1
3	USB	1	USB	Shielded	1.8
4	Serial	1	Ribbon Cable Connector	Un-Shielded	0.25
5	Antenna	1	SMA	Un-Shielded	0.025

### TEST SETUP

Test software exercised the radio card.



**SETUP DIAGRAM FOR CONDUCTED TESTS**

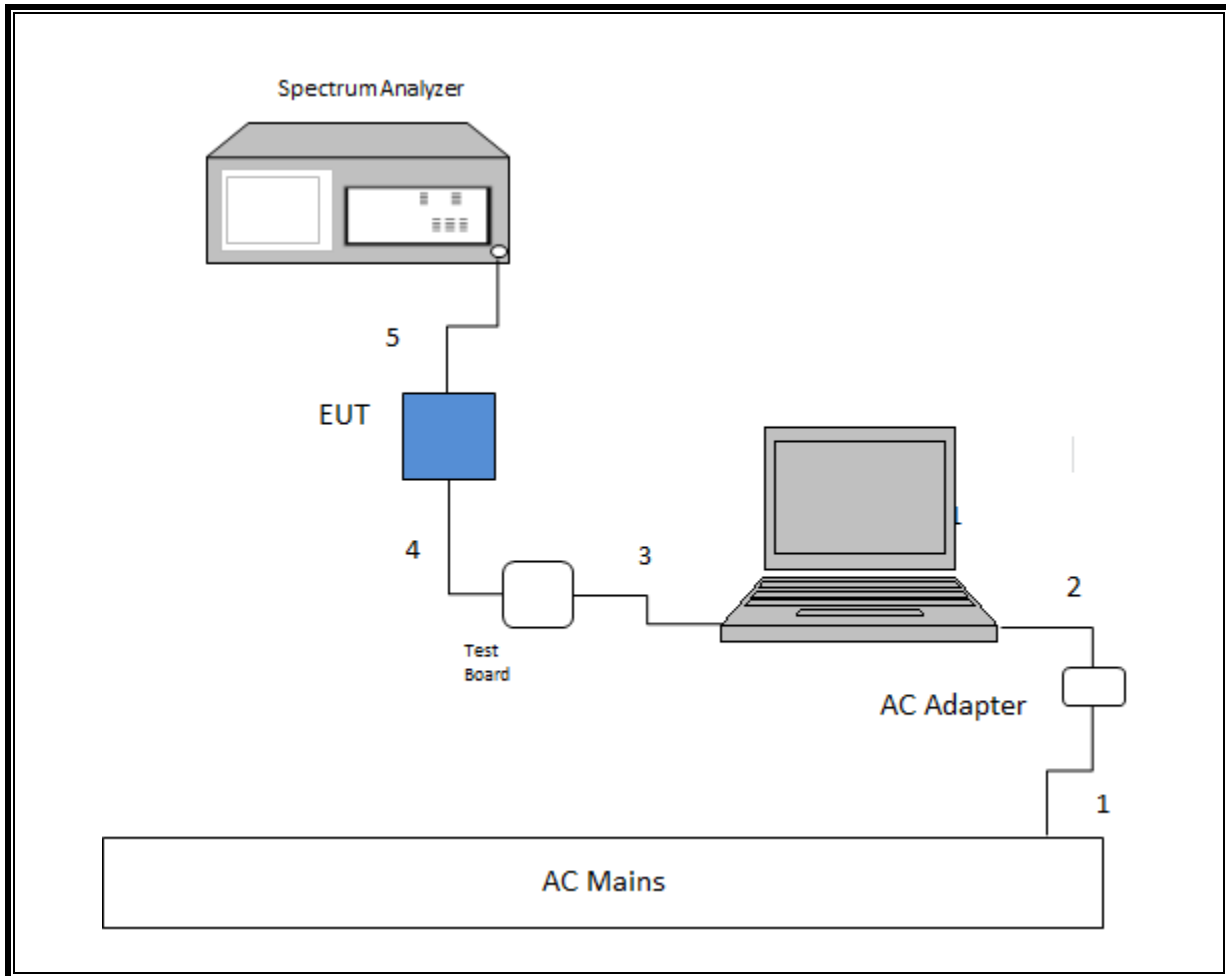

**SETUP DIAGRAM FOR RADIATED TESTS**

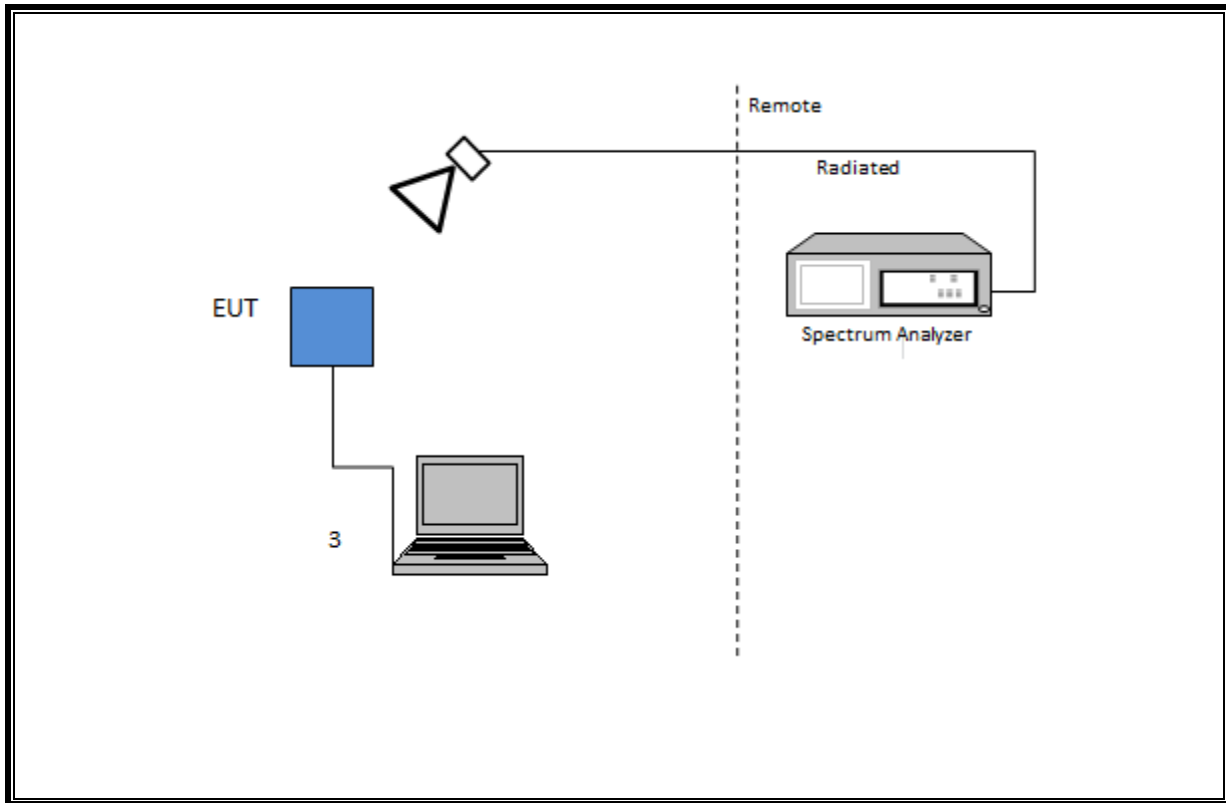

**SETUP DIAGRAM FOR LINE CONDUCTED TEST**

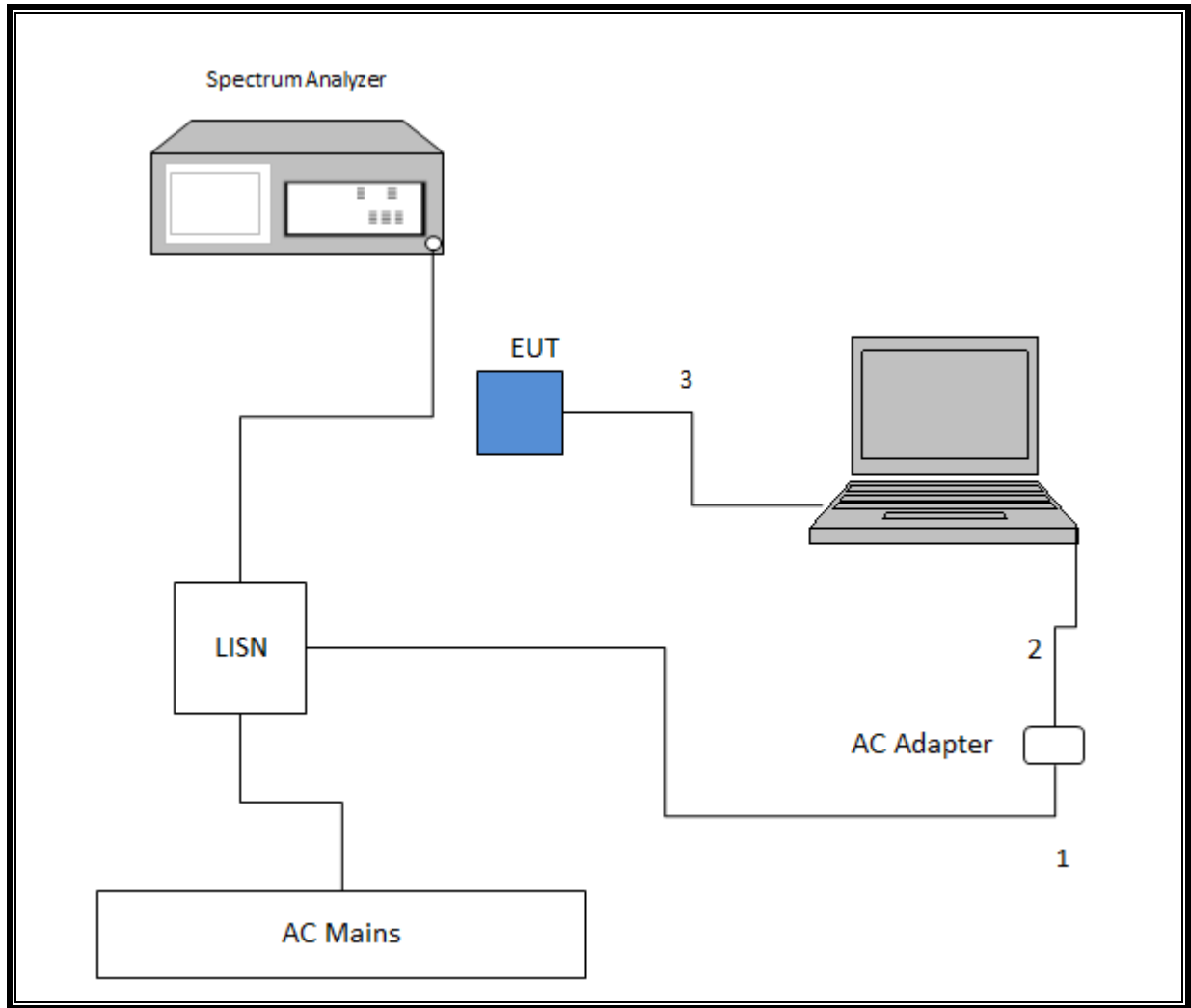

## 6. TEST AND MEASUREMENT EQUIPMENT

The following test and measurement equipment was utilized for the tests documented in this report:

Test Equipment List					
Description	Manufacturer	Model	T No.	Cal Date	Cal Due
Radiated Software	UL	UL EMC	Ver 9.5		
Conducted Software	UL	UL EMC	Ver 4.1		
Spectrum Analyzer, PXA, 3Hz to 44GHz	Keysight	N9030A	906	6/11/2015	6/11/2016
Antenna, Horn 1-18GHz	ETS Lindgren	3117	863	4/10/2015	4/10/2016
Antenna, Broadband Hybrid, 30 to 2000MHz	Sunol Sciences	JB3	900	4/10/2015	4/10/2016
Amplifier, 1-18GHz	Miteq	AFS42-00101800-25-S-42	495	10/21/2015	10/21/2016
Spectrum Analyzer, PXA, 3Hz to 44GHz	Keysight	N9030A	1210	5/22/2015	5/22/2016
Amplifier, 10kHz to 1GHz	Sonoma	310N	835	6/9/2015	6/9/2016
Power Meter	Keysight	N1911A	1244	7/2/2015	7/2/2016
Power Sensor	Keysight	N1921A	1226	7/6/2015	7/6/2016
Amplifier, 1-26.5GHz	Keysight	8449B	404	6/29/2015	6/29/2016
Antenna, Horn 18 - 26GHz	ARA	MWH-1826	447	5/12/2015	5/12/2016
Spectrum Analyzer, 40GHz	Keysight	8564E	106	8/14/2015	8/14/2016
Filter, HPF 3.0GHz	Micro-Tronics	HPM17543	427	1/31/2015	1/31/2016

## 7. ANTENNA PORT TEST RESULTS

### 7.1. MEASUREMENT METHODS

6 dB BW: KDB 558074 D01 v03r04, Section 8.1.

Output Power: KDB 558074 D01 v03r04, Section 9.1.2.

Power Spectral Density: KDB 558074 D01 v03r04, Section 10.2.

Out-of-band emissions in non-restricted bands: KDB 558074 D01 v03r04, Section 11.0.

Out-of-band emissions in restricted bands: KDB 558074 D01 v03r04, Section 12.1.

Band-edge: KDB 558074 D01 v03r04, Section 12.1

## 7.2. ON TIME, DUTY CYCLE

None; for reporting purposes only.

### PROCEDURE

KDB 558074 Zero-Span Spectrum Analyzer Method.

### ON TIME AND DUTY CYCLE RESULTS

Mode	ON Time B (msec)	Period (msec)	Duty Cycle x (linear)	Duty Cycle (%)	Duty Cycle Correction Factor (dB)	1/B Minimum VBW (kHz)
BLE	0.173	0.625	0.276	27.64%	5.58	5.787

### DUTY CYCLE PLOTS

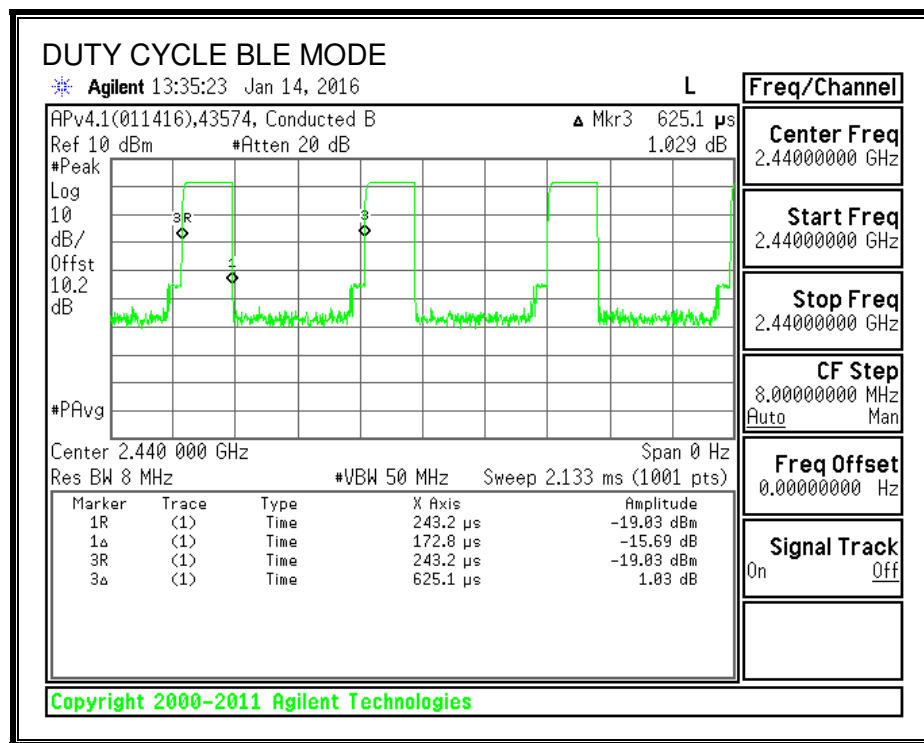

### 7.3. 6 dB BANDWIDTH

#### LIMITS

FCC §15.247 (a) (2)

IC RSS-247 (5.2) (1)

The minimum 6 dB bandwidth shall be at least 500 kHz.

#### RESULTS

Channel	Frequency (MHz)	6 dB Bandwidth (MHz)	Minimum Limit (MHz)
Low	2402	0.655	0.5
Middle	2440	0.653	0.5
High	2480	0.644	0.5

**6 dB BANDWIDTH**

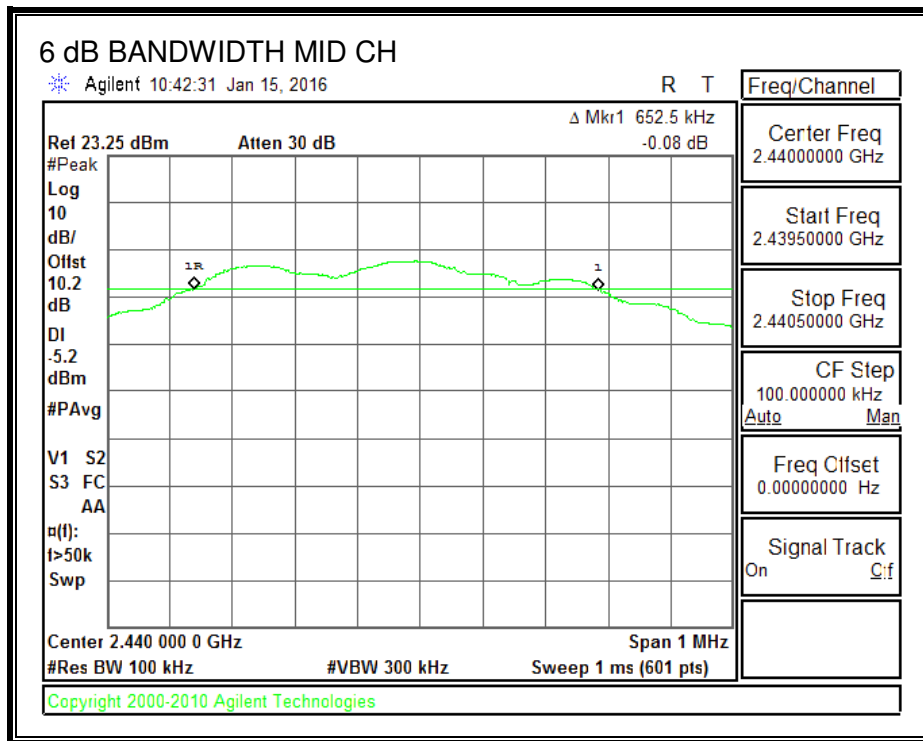
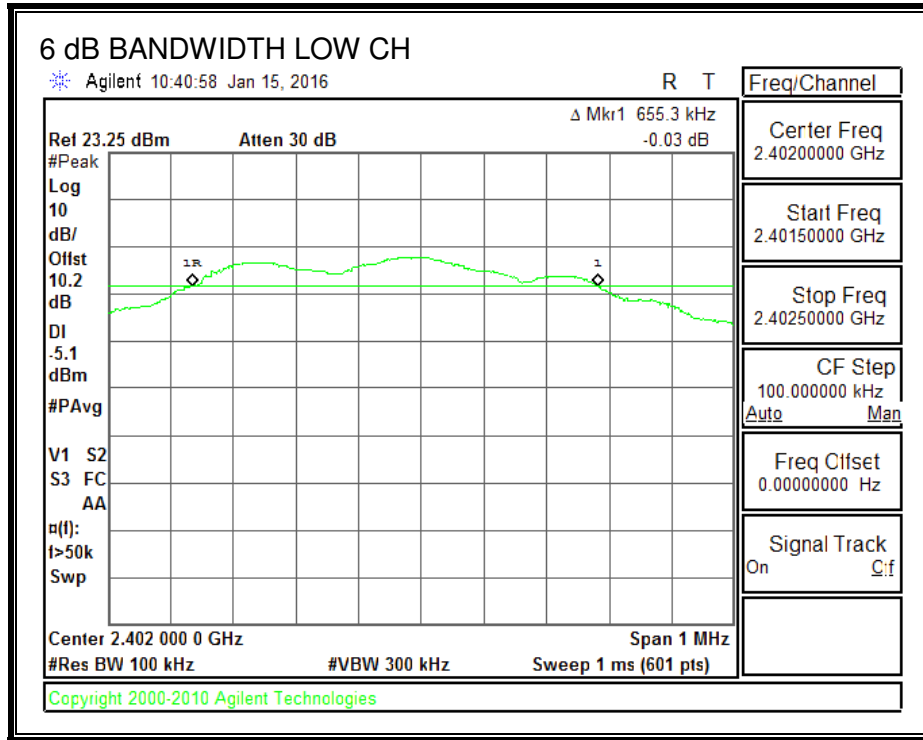



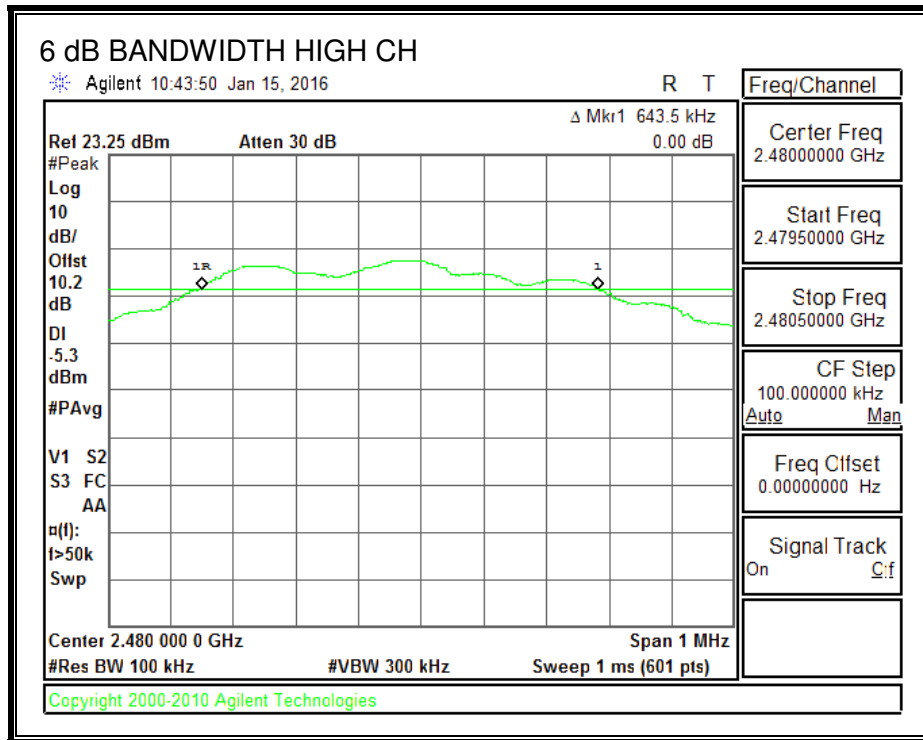

## 7.4. 99% BANDWIDTH

### LIMITS

None; for reporting purposes only.

### TEST PROCEDURE

The transmitter output is connected to the spectrum analyzer. The RBW is set to 1% to 3% of the 99 % bandwidth and to 1% of the span. The VBW is set to 3 times the RBW. The sweep time is coupled. The spectrum analyzer internal 99% bandwidth function is utilized.

### RESULTS

Frequency (MHz)	99% Bandwidth (MHz)
2402	0.97373
2440	0.97246
2480	0.97701

**99% BANDWIDTH**

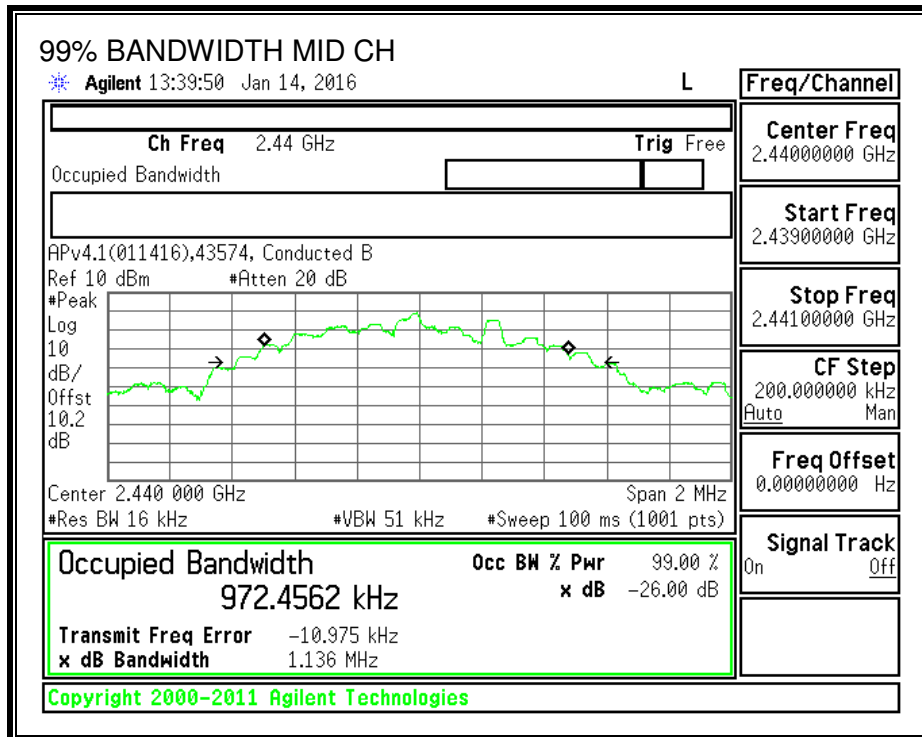
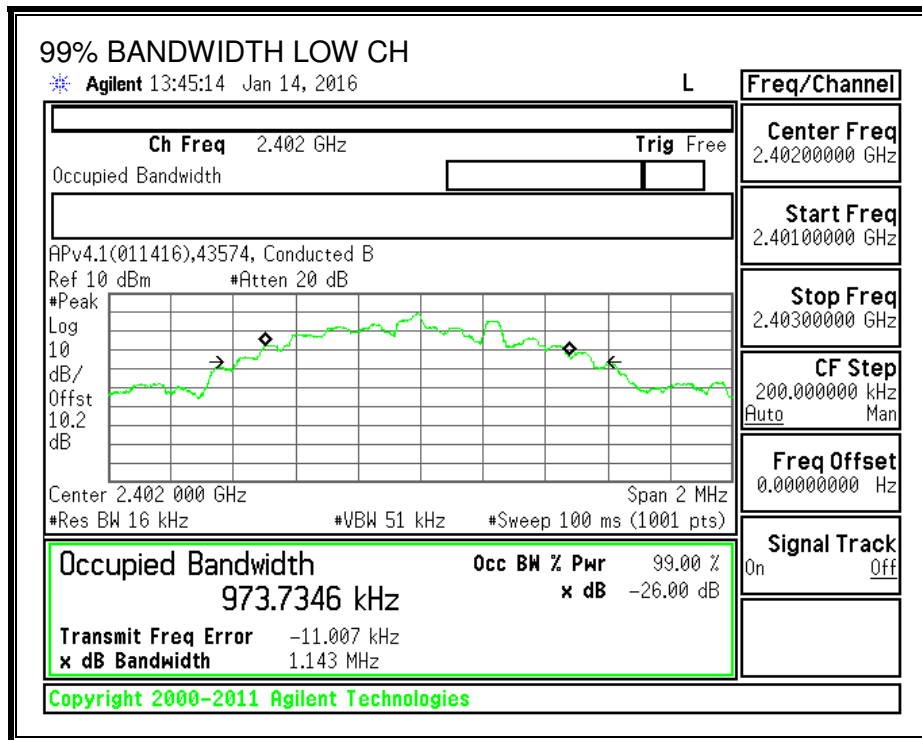

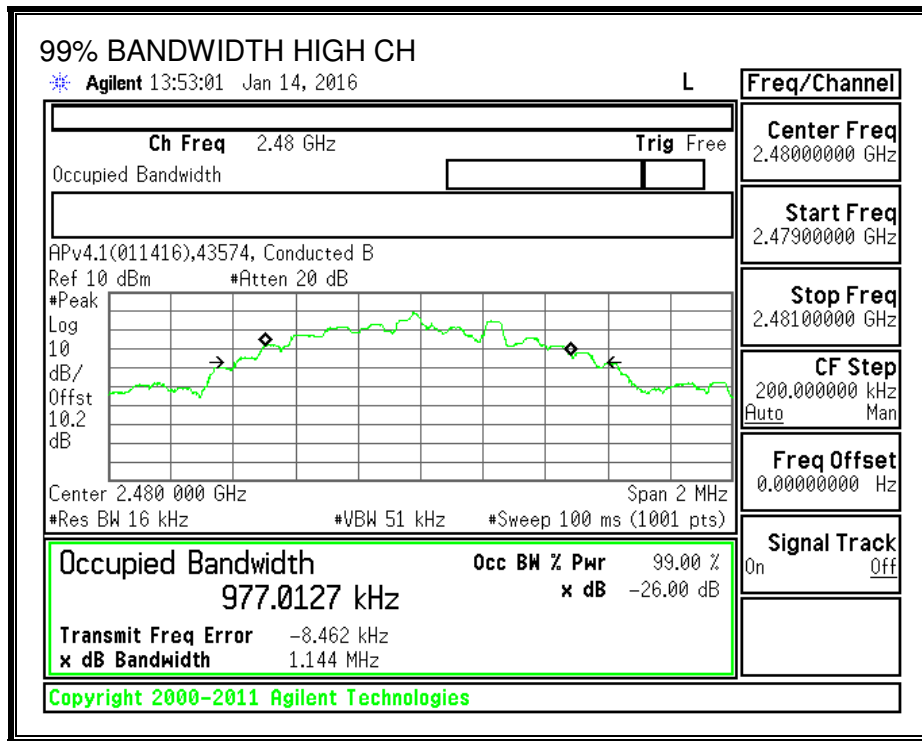

## 7.5. OUTPUT POWER

### LIMITS

FCC §15.247 (b)

IC RSS-247 (5.4) (4)

The maximum antenna gain is less than or equal to 6 dBi, therefore the limit is 30 dBm.

### RESULTS

Channel	Frequency (MHz)	Peak Power Reading (dBm)	Limit (dBm)	Margin (dB)
Low	2402	1.75	30	-28.25
Middle	2440	1.47	30	-28.53
High	2480	1.37	30	-28.63

**OUTPUT POWER**

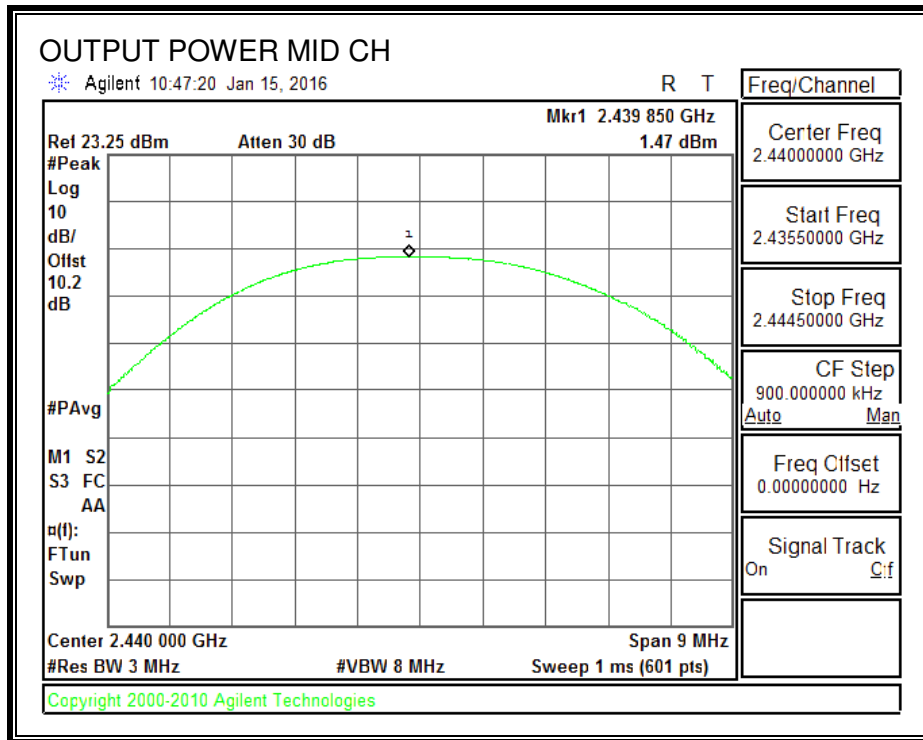
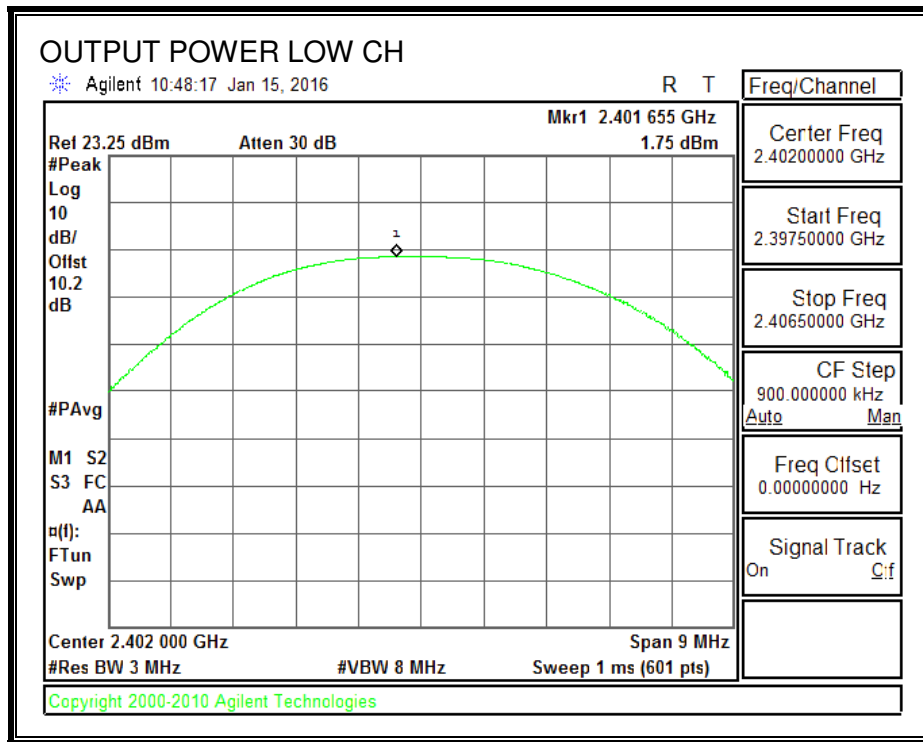

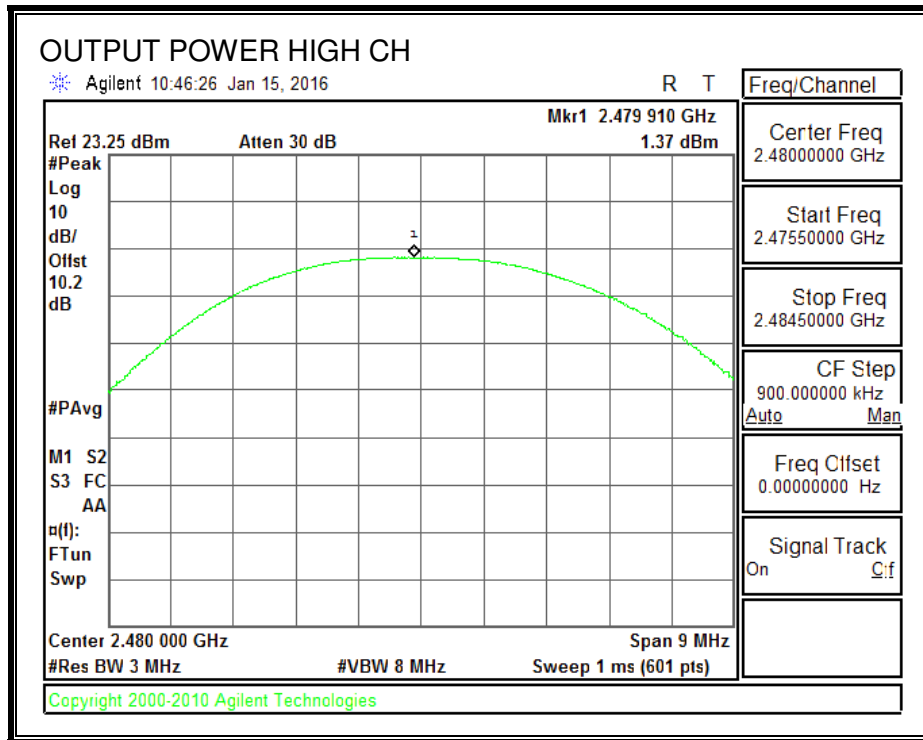

## 7.6. AVERAGE POWER

### LIMITS

None; for reporting purposes only.

### RESULTS

The cable assembly insertion loss of 10.25 dB (including 10 dB pad and 0.25 dB cable) was entered as an offset in the power meter to allow for direct reading of power.

Channel	Frequency (MHz)	AV power (dBm)
Low	2402	1.19
Middle	2440	0.76
High	2480	0.32



## 7.7. POWER SPECTRAL DENSITY

### LIMITS

FCC §15.247 (e)

IC RSS-247 (5.2) (2)

The power spectral density conducted from the transmitter to the antenna shall not be greater than 8 dBm in any 3 kHz band during any time interval of continuous transmission.

### RESULTS

Channel	Frequency (MHz)	PSD (dBm)	Limit (dBm)	Margin (dB)
Low	2402	0.917	8	-7.08
Middle	2440	-0.186	8	-8.19
High	2480	-3.585	8	-11.59

**POWER SPECTRAL DENSITY**

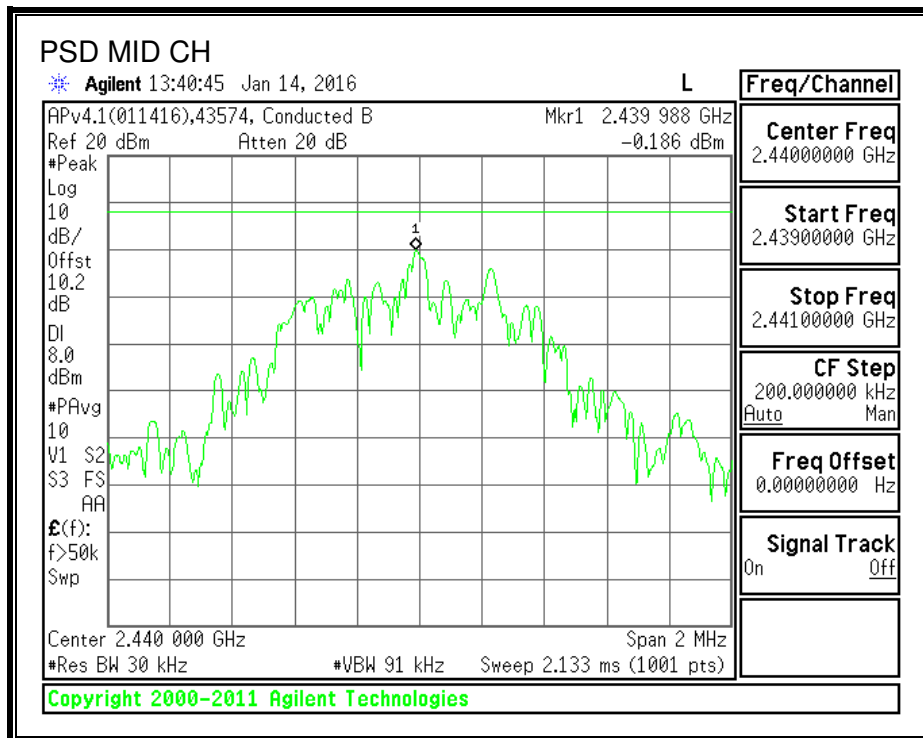
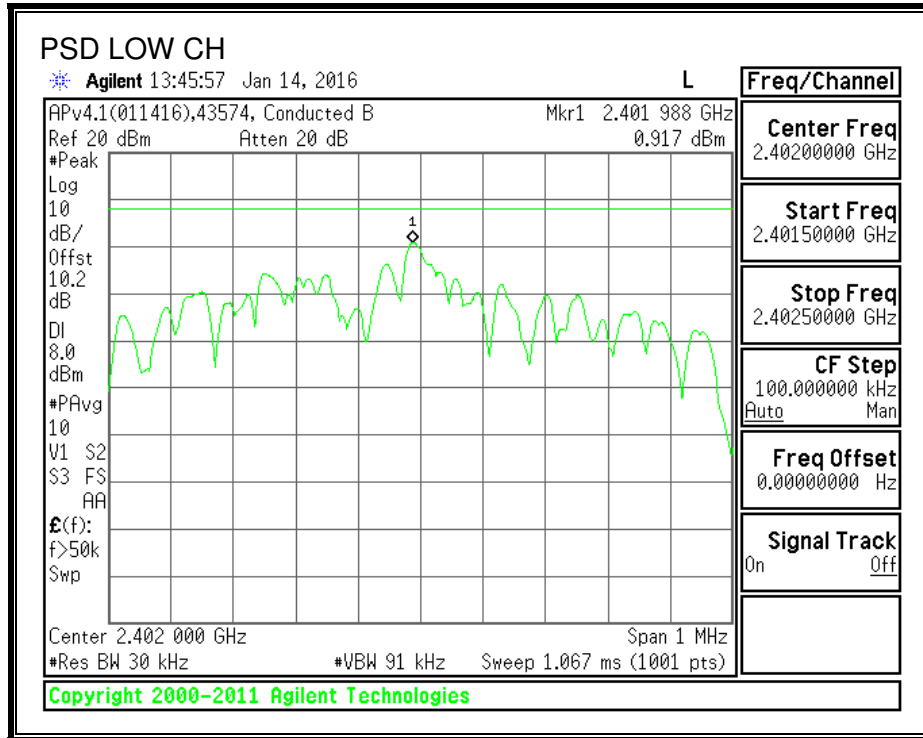

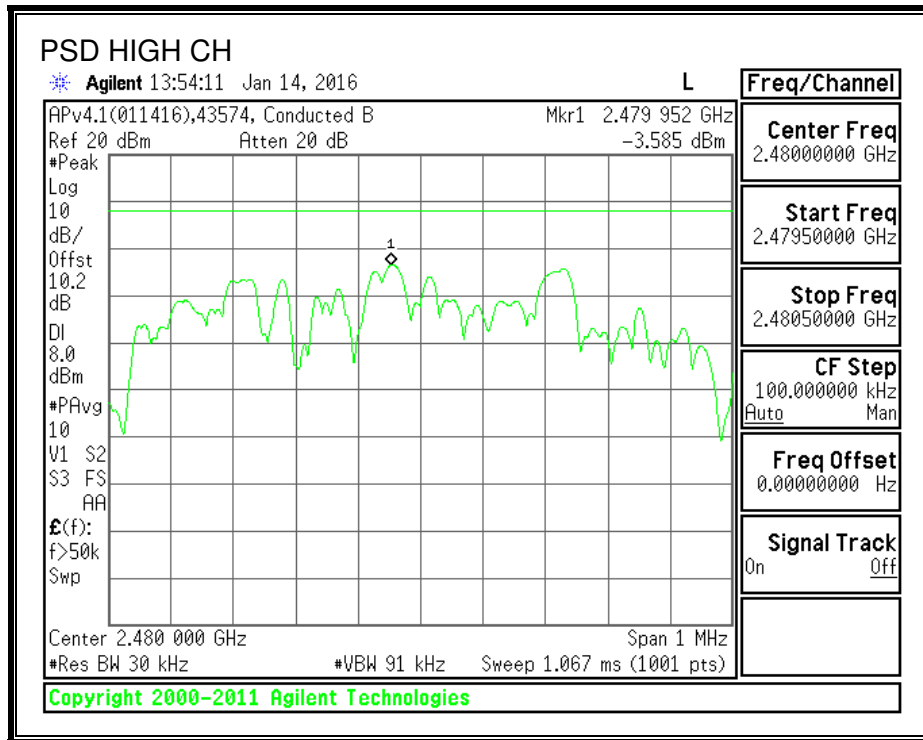

## **7.8. CONDUCTED SPURIOUS EMISSIONS**

### **LIMITS**

FCC §15.247 (d)

IC RSS-247 (5.5)

Output power was measured based on the use of a peak measurement, therefore the required attenuation is 20 dB.

**RESULTS**

**SPURIOUS EMISSIONS, LOW CHANNEL**

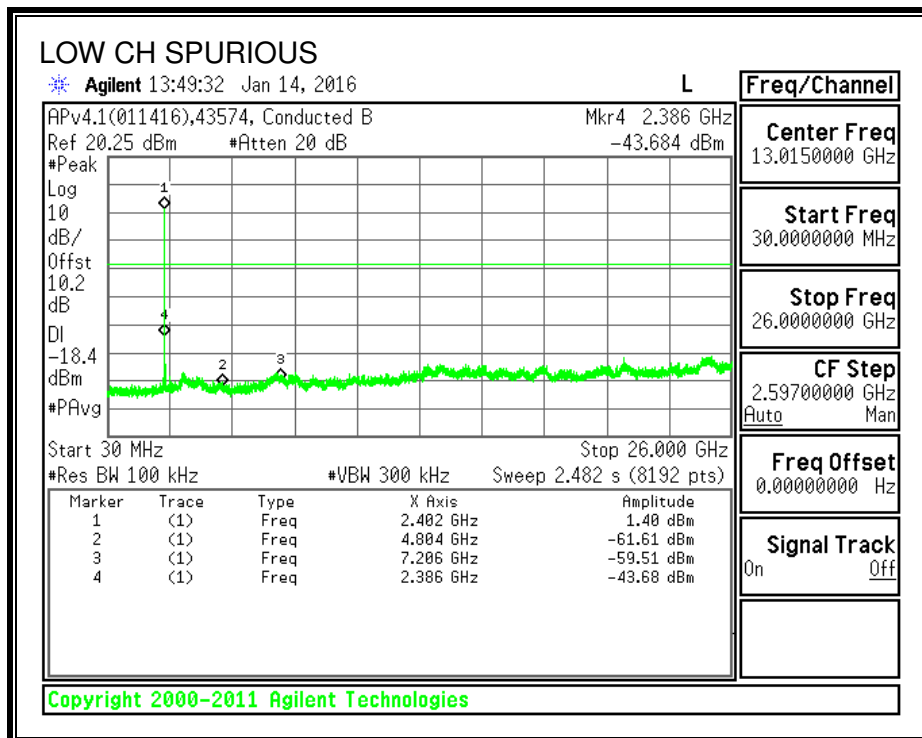
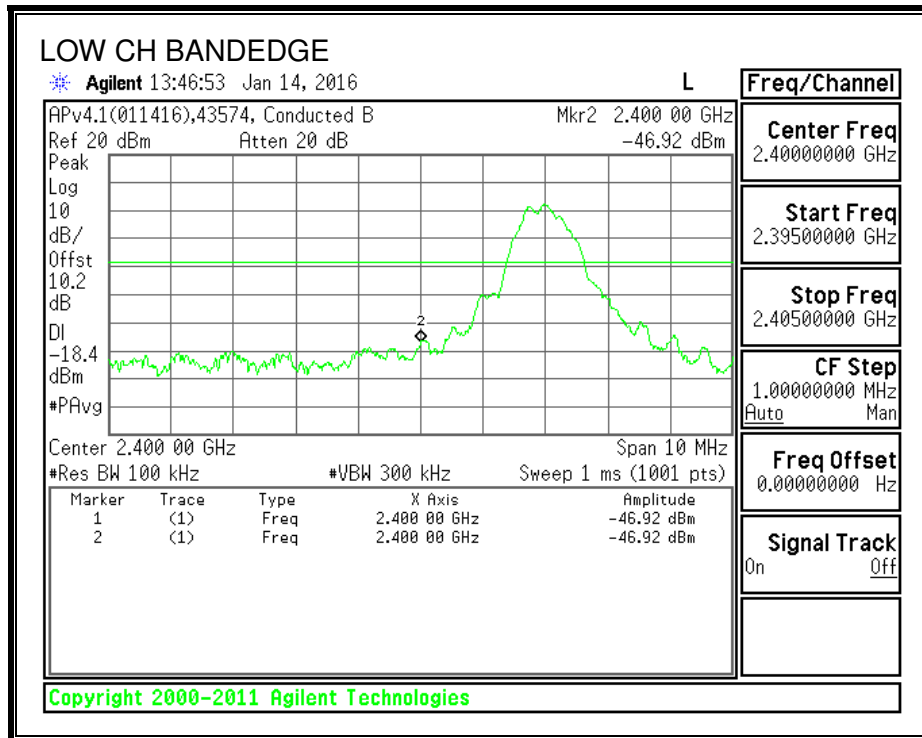

**SPURIOUS EMISSIONS, MID CHANNEL**

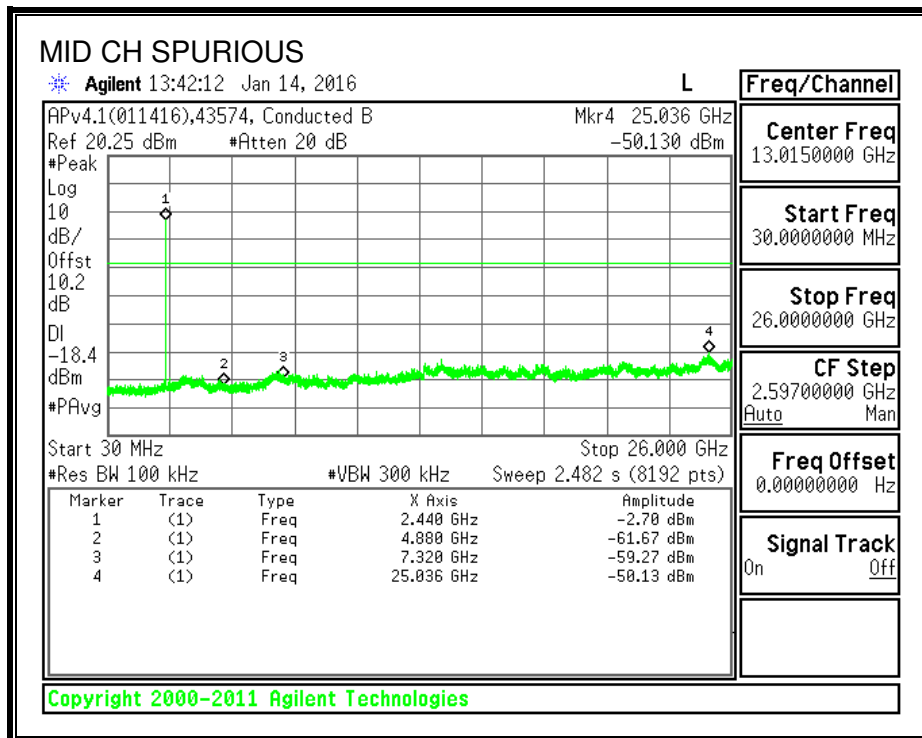
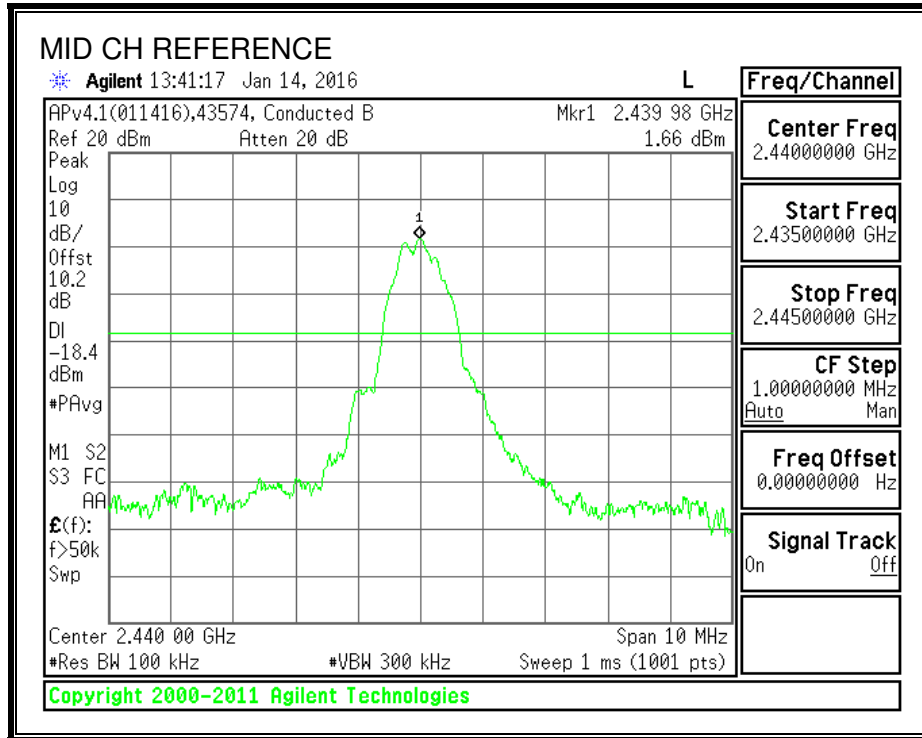

**SPURIOUS EMISSIONS, HIGH CHANNEL**

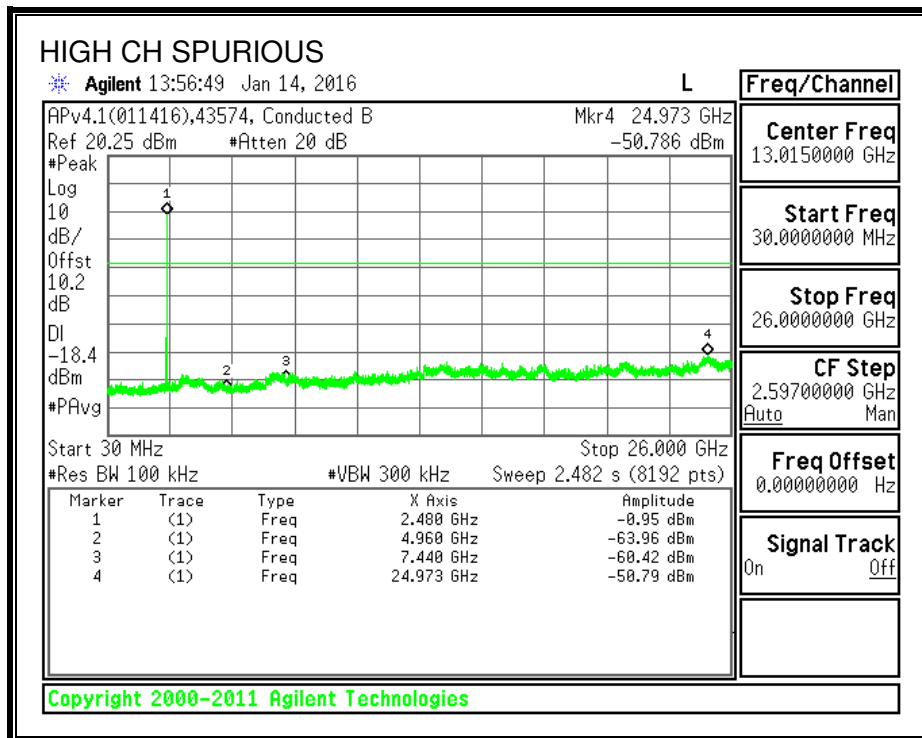
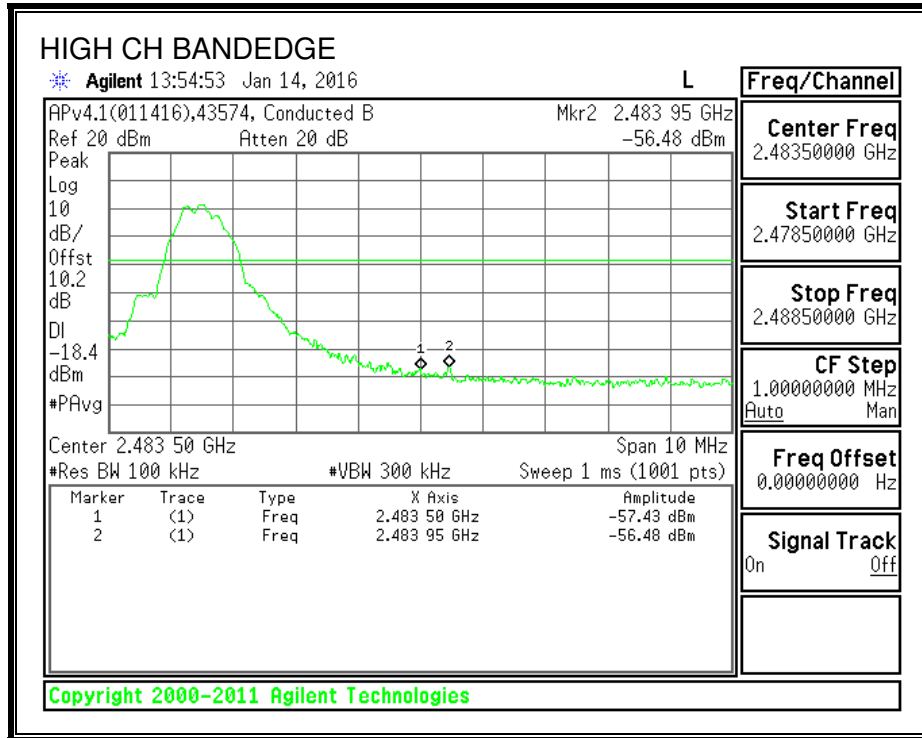

## 8. RADIATED TEST RESULTS

### 8.1. LIMITS AND PROCEDURE

#### LIMITS

FCC §15.205 and §15.209

IC RSS-GEN Clause 8.9 and 8.10

Frequency Range (MHz)	Field Strength Limit (uV/m) at 3 m	Field Strength Limit (dBuV/m) at 3 m
30 - 88	100	40
88 - 216	150	43.5
216 - 960	200	46
Above 960	500	54



## 8.2. TRANSMITTER ABOVE 1 GHz

### RESTRICTED BANDEGE (LOW CHANNEL)

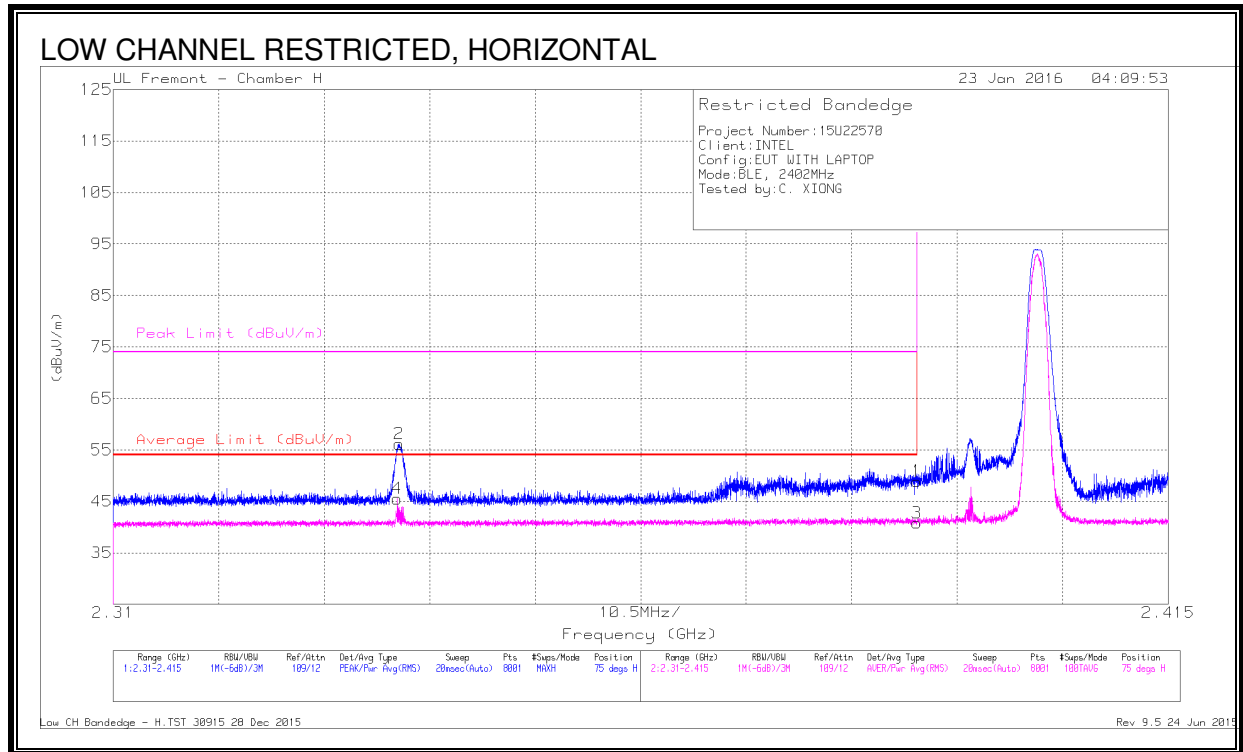

### DATA

Marker	Frequency (GHz)	Meter Reading (dBuV)	Det	AF T863 (dB/m)	Amp/Cb/Filter/Pad (dB)	DC Corr (dB)	Corrected Reading (dBuV/m)	Average Limit (dBuV/m)	Margin (dB)	Peak Limit (dBuV/m)	PK Margin (dB)	Azimuth (Degs)	Height (cm)	Polarity
1	* 2.39	39.29	Pk	32	-22.4	0	48.89	-	-	74	-25.11	75	124	H
2	* 2.338	46.65	Pk	31.9	-22.4	0	56.15	-	-	74	-17.85	75	124	H
3	* 2.39	25.63	RMS	32	-22.4	5.58	40.81	54	-13.19	-	-	75	124	H
4	* 2.338	30.44	RMS	31.9	-22.4	5.58	45.52	54	-8.48	-	-	75	124	H

\* - indicates frequency in CFR15.205/IC7.2.2 Restricted Band

Pk - Peak detector

RMS - RMS detection

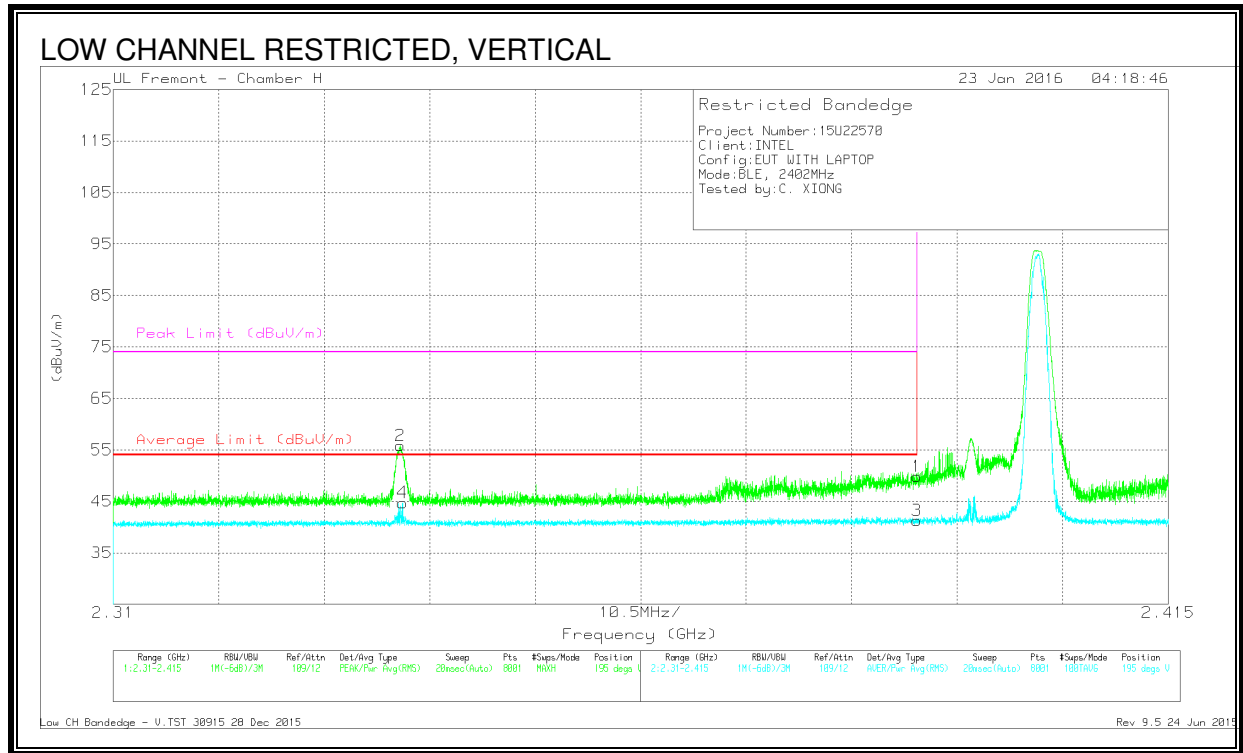

**DATA**

Marker	Frequency (GHz)	Meter Reading (dBuV)	Det	AF T863 (dB/m)	Amp/Cb/Filter/Pad (dB)	DC Corr (dB)	Corrected Reading (dBuV/m)	Average Limit (dBuV/m)	Margin (dB)	Peak Limit (dBuV/m)	PK Margin (dB)	Azimuth (Degs)	Height (cm)	Polarity
2	* 2.339	46.31	PK	31.9	-22.4	0	55.81	-	-	74	-18.19	195	102	V
4	* 2.339	29.66	RMS	31.9	-22.4	5.58	44.74	54	-9.26	-	-	195	102	V
1	* 2.39	40.24	PK	32	-22.4	0	49.84	-	-	74	-24.16	195	102	V
3	* 2.39	26.08	RMS	32	-22.4	5.58	41.26	54	-12.74	-	-	195	102	V

\* - indicates frequency in CFR15.205/IC7.2.2 Restricted Band

PK - Peak detector

RMS - RMS detection

**RESTRICTED BANDEGE (HIGH CHANNEL)**

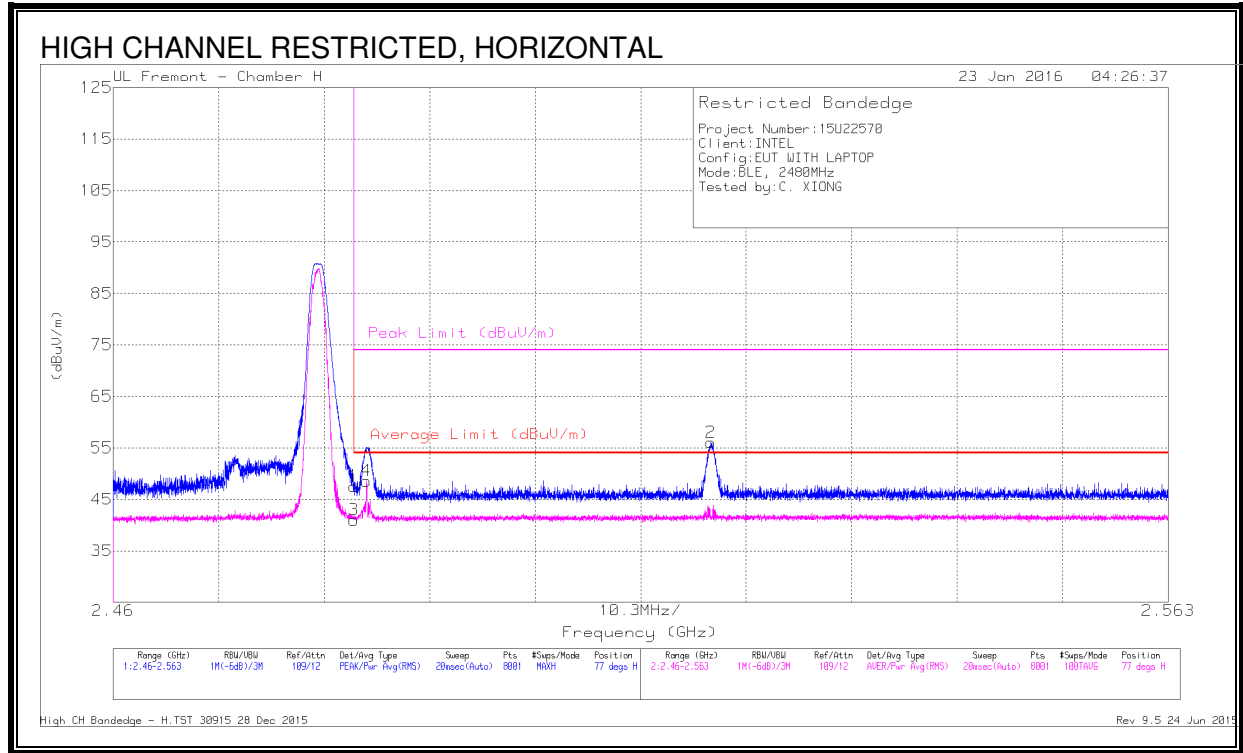

**DATA**

Marker	Frequency (GHz)	Meter Reading (dBuV)	Det	AF T863 (dB/m)	Amp/Cb/Filter/Pad (dB)	DC Corr (dB)	Corrected Reading (dBuV/m)	Average Limit (dBuV/m)	Margin (dB)	Peak Limit (dBuV/m)	PK Margin (dB)	Azimuth (Degs)	Height (cm)	Polarity
1	* 2.484	37.66	Pk	32.4	-22.5	0	47.56	-	-	74	-26.44	77	141	H
3	* 2.484	25.51	RMS	32.4	-22.5	5.58	40.99	54	-13.01	-	-	77	141	H
4	* 2.485	33.09	RMS	32.4	-22.5	5.58	48.57	54	-5.43	-	-	77	141	H
2	2.518	45.95	Pk	32.5	-22.4	0	56.05	-	-	74	-17.95	77	141	H

\* - indicates frequency in CFR15.205/IC7.2.2 Restricted Band

Pk - Peak detector

RMS - RMS detection

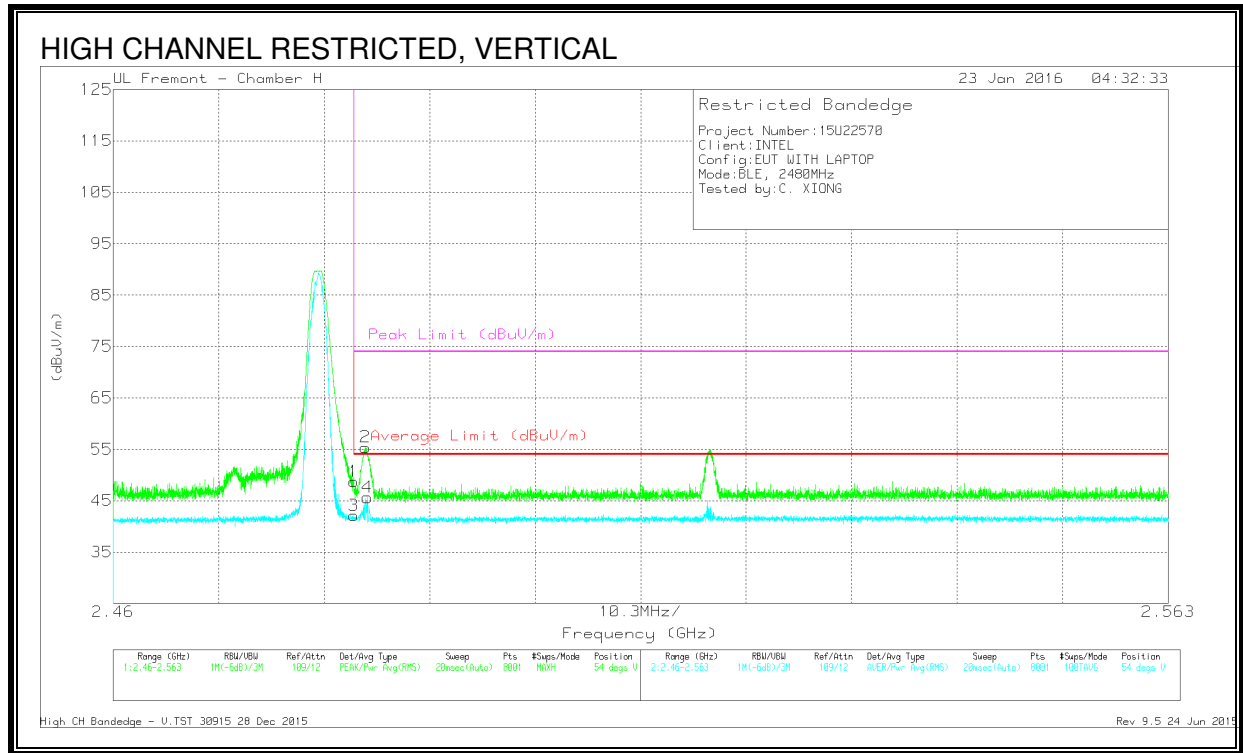

**DATA**

Marker	Frequency (GHz)	Meter Reading (dBuV)	Det	AF T863 (dB/m)	Amp/Cb/Fitter/Pad (dB)	DC Corr (dB)	Corrected Reading (dBuV/m)	Average Limit (dBuV/m)	Margin (dB)	Peak Limit (dBuV/m)	PK Margin (dB)	Azimuth (Degs)	Height (cm)	Polarity
1	* 2.484	38.85	Pk	32.4	-22.5	0	48.75	-	-	74	-25.25	54	140	V
3	* 2.484	26.67	RMS	32.4	-22.5	5.58	42.15	54	-11.85	-	-	54	140	V
2	* 2.485	45.49	Pk	32.4	-22.5	0	55.39	-	-	74	-18.61	54	140	V
4	* 2.485	30.16	RMS	32.4	-22.5	5.58	45.64	54	-8.36	-	-	54	140	V

\* - indicates frequency in CFR15.205/IC7.2.2 Restricted Band

Pk - Peak detector

RMS - RMS detection

**HARMONICS AND SPURIOUS EMISSIONS**

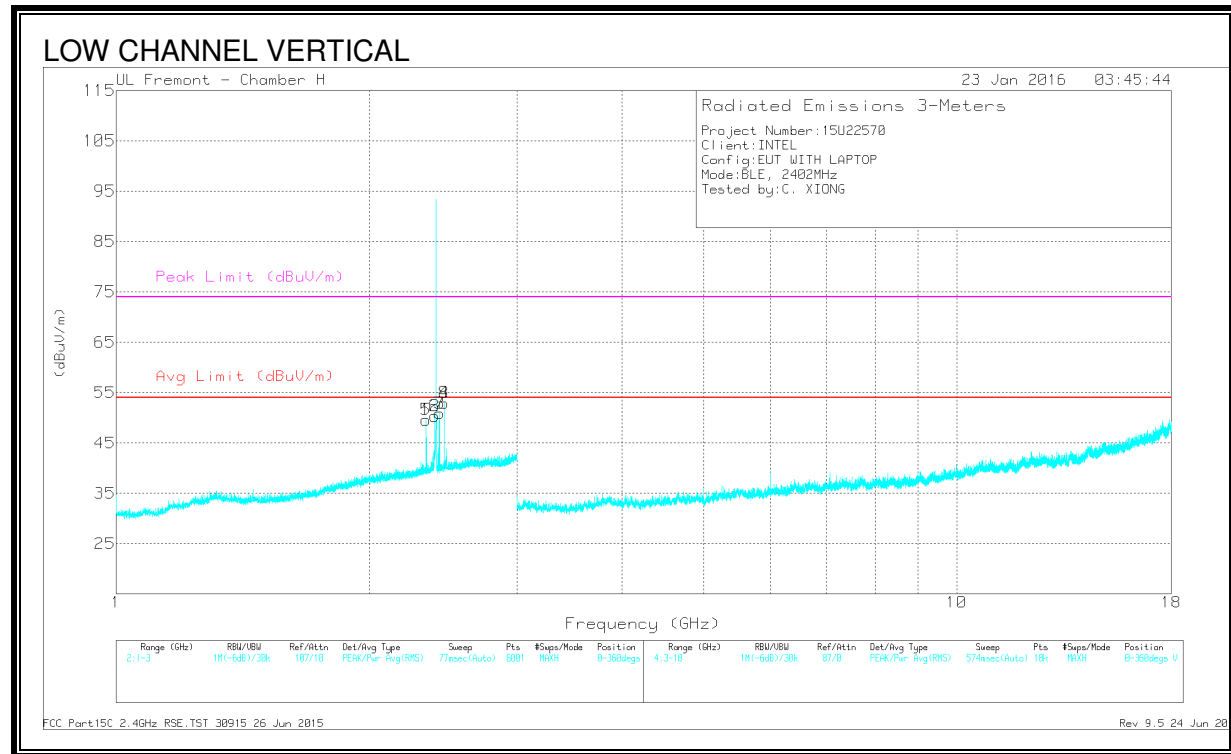
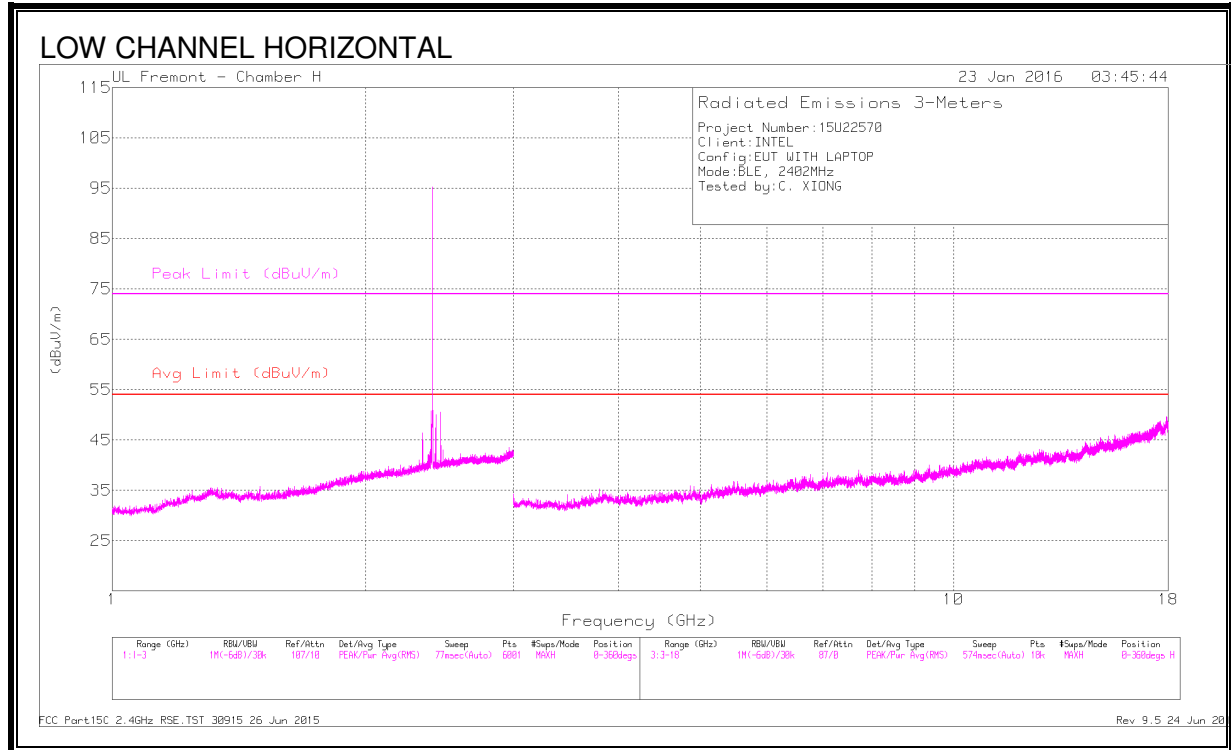

**DATA**

Marker	Frequenc y (GHz)	Meter Reading (dBuV)	Det	AF T863 (dB/m)	Amp/Cbl/ Fitr/Pad (dB)	DC Corr (dB)	Corrected Reading (dBuV/m)	Avg Limit (dBuV/m)	Margin (dB)	Peak Limit (dBuV/m)	PK Margin (dB)	Azimuth (Degs)	Height (cm)	Polarity
1	* 2.338	45.78	PK2	31.9	-22.4	0	55.28	-	-	74	-18.72	161	198	V
	* 2.338	31.73	MAv1	31.9	-22.4	5.58	46.81	54	-7.19	-	-	161	198	V
5	* 2.338	45.69	PK2	31.9	-22.4	0	55.19	-	-	74	-18.81	332	157	V
	* 2.338	31.34	MAv1	31.9	-22.4	5.58	46.42	54	-7.58	-	-	332	157	V
2	2.395	40.76	Pk	32	-22.4	0	50.36	-	-	-	-	0-360	100	V
6	2.395	40.76	Pk	32	-22.4	0	50.36	-	-	-	-	0-360	100	V
3	2.425	41.28	Pk	32.1	-22.5	0	50.88	-	-	-	-	0-360	200	V
7	2.425	41.28	Pk	32.1	-22.5	0	50.88	-	-	-	-	0-360	200	V
4	2.457	43.15	Pk	32.3	-22.5	0	52.95	-	-	-	-	0-360	200	V
8	2.457	43.15	Pk	32.3	-22.5	0	52.95	-	-	-	-	0-360	200	V

\* - indicates frequency in CFR15.205/IC7.2.2 Restricted Band

PK2 - KDB558074 Method: Maximum Peak

MAv1 - KDB558074 Option 1 Maximum RMS Average

Pk - Peak detector

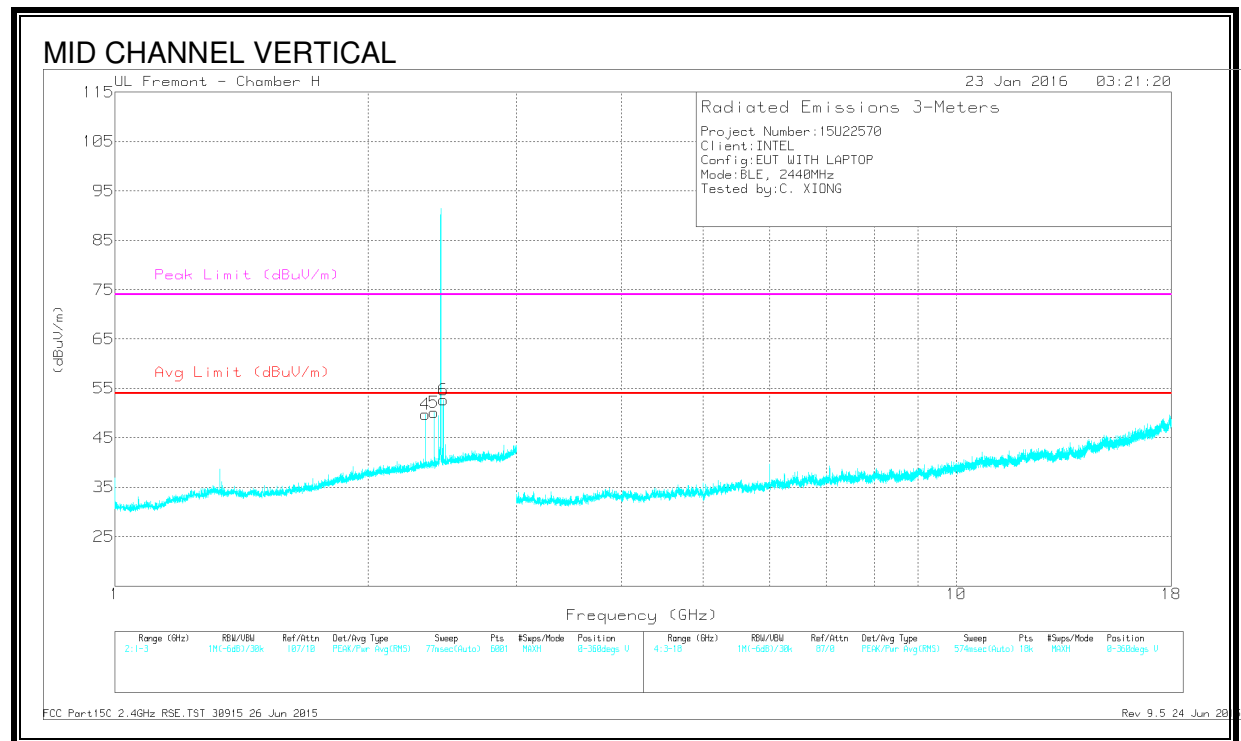
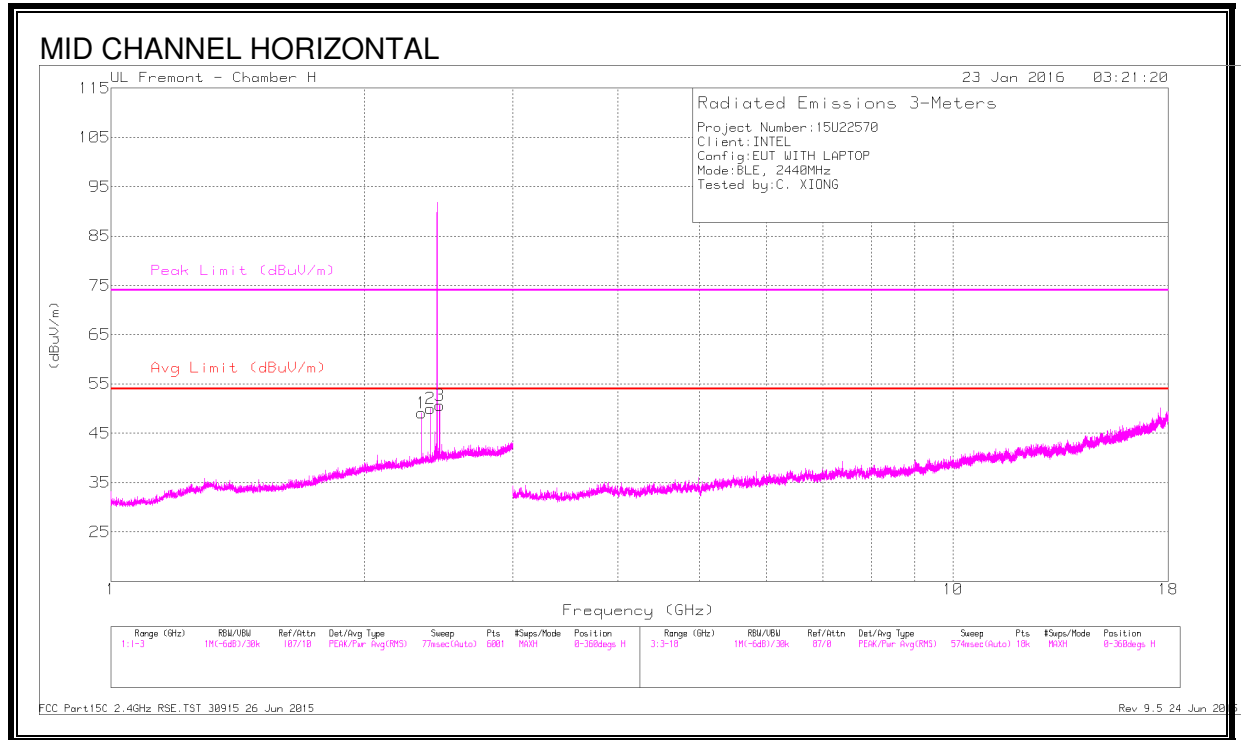

**DATA**

Marker	Frequenc y (GHz)	Meter Reading (dBuV)	Det	AF T863 (dB/m)	Amp/Cbl/ Filtr/Pad (dB)	DC Corr (dB)	Corrected Reading (dBuV/m)	Avg Limit (dBuV/m)	Margin (dB)	Peak Limit (dBuV/m)	PK Margin (dB)	Azimuth (Degs)	Height (cm)	Polarity
1	* 2.339	46.98	PK2	31.9	-22.4	0	56.48	-	-	74	-17.52	81	118	H
	* 2.338	29.21	MAv1	31.9	-22.4	5.58	44.29	54	-9.71	-	-	81	118	H
4	* 2.338	45.59	PK2	31.9	-22.4	0	55.09	-	-	74	-18.91	198	118	V
	* 2.339	27.58	MAv1	31.9	-22.4	5.58	42.66	54	-11.34	-	-	198	118	V
2	2.395	40.41	Pk	32	-22.4	0	50.01	-	-	-	-	0-360	100	H
5	2.395	40.56	Pk	32	-22.4	0	50.16	-	-	-	-	0-360	200	V
3	2.457	40.86	Pk	32.3	-22.5	0	50.66	-	-	-	-	0-360	201	H
6	2.457	42.88	Pk	32.3	-22.5	0	52.68	-	-	-	-	0-360	100	V

\* - indicates frequency in CFR15.205/IC7.2.2 Restricted Band

PK2 - KDB558074 Method: Maximum Peak

MAv1 - KDB558074 Option 1 Maximum RMS Average

Pk - Peak detector



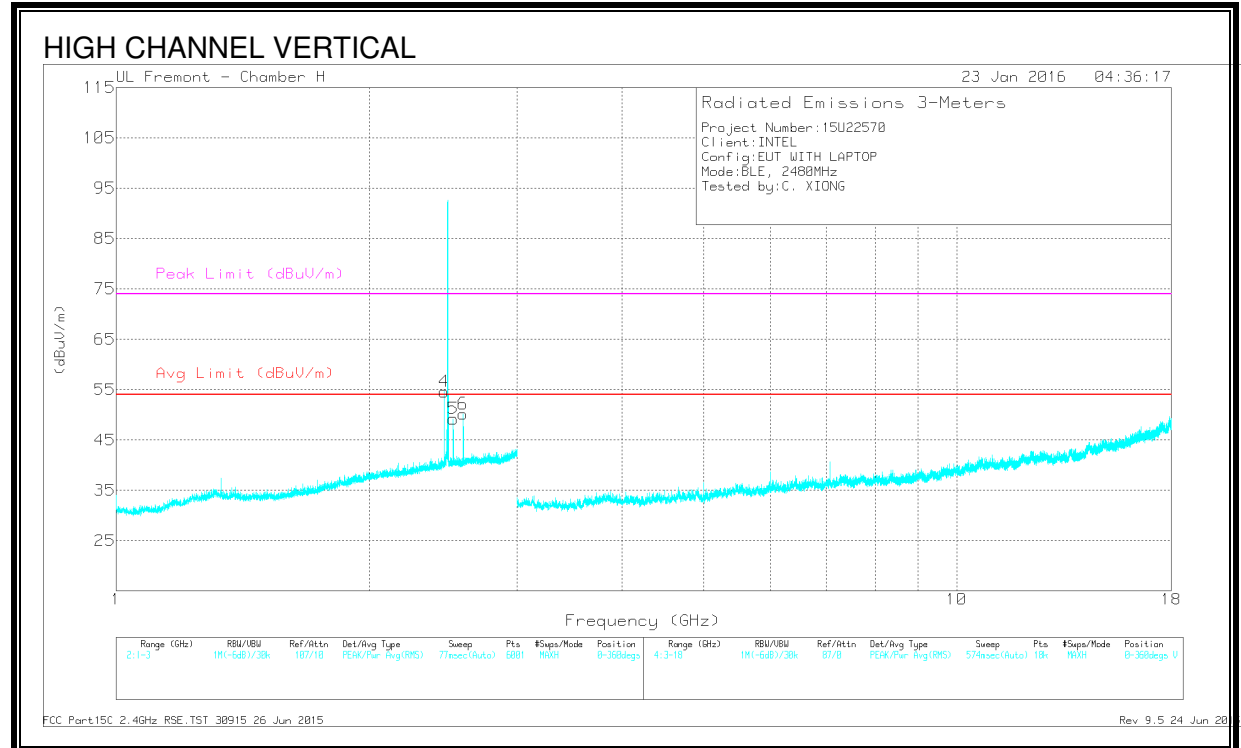
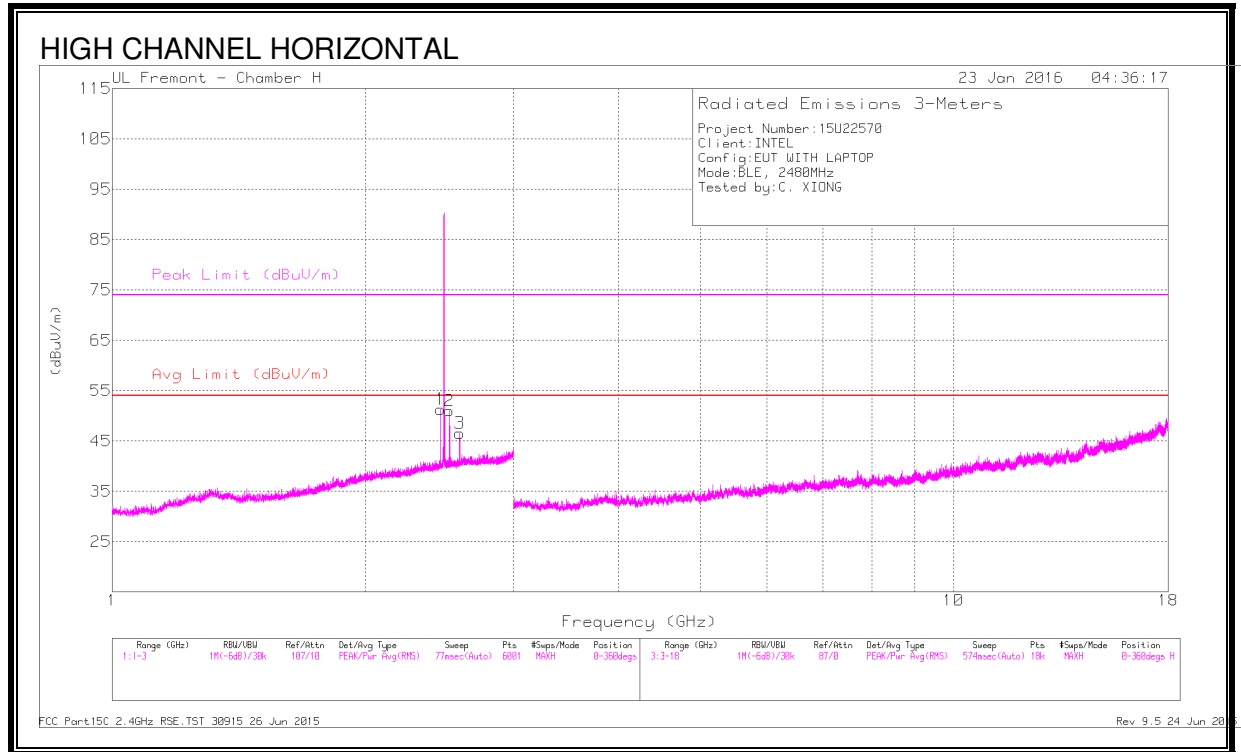

**DATA**

Marker	Frequency (GHz)	Meter Reading (dBuV)	Det	AF T863 (dB/m)	Amp/Cb/Filtr /Pad (dB)	DC Corr (dB)	Corrected Reading (dBuV/m)	Avg Limit (dBuV/m)	Margin (dB)	Peak Limit (dBuV/m)	PK Margin (dB)	Azimuth (Degs)	Height (cm)	Polarity
1	2.457	41.49	Pk	32.3	-22.5	0	51.29	-	-	-	-	0-360	100	H
4	2.457	44.8	Pk	32.3	-22.5	0	54.6	-	-	-	-	0-360	100	V
2	2.518	40.92	Pk	32.5	-22.4	0	51.02	-	-	-	-	0-360	100	H
5	2.518	39.12	Pk	32.5	-22.4	0	49.22	-	-	-	-	0-360	200	V
6	2.588	39.87	Pk	32.5	-22.2	0	50.17	-	-	-	-	0-360	200	V
3	2.589	36.27	Pk	32.5	-22.2	0	46.57	-	-	-	-	0-360	100	H

Pk - Peak detector

### 8.3. WORST-CASE BELOW 1 GHz

#### SPURIOUS EMISSIONS 30 TO 1000 MHz (WORST-CASE CONFIGURATION, HORIZONTAL)

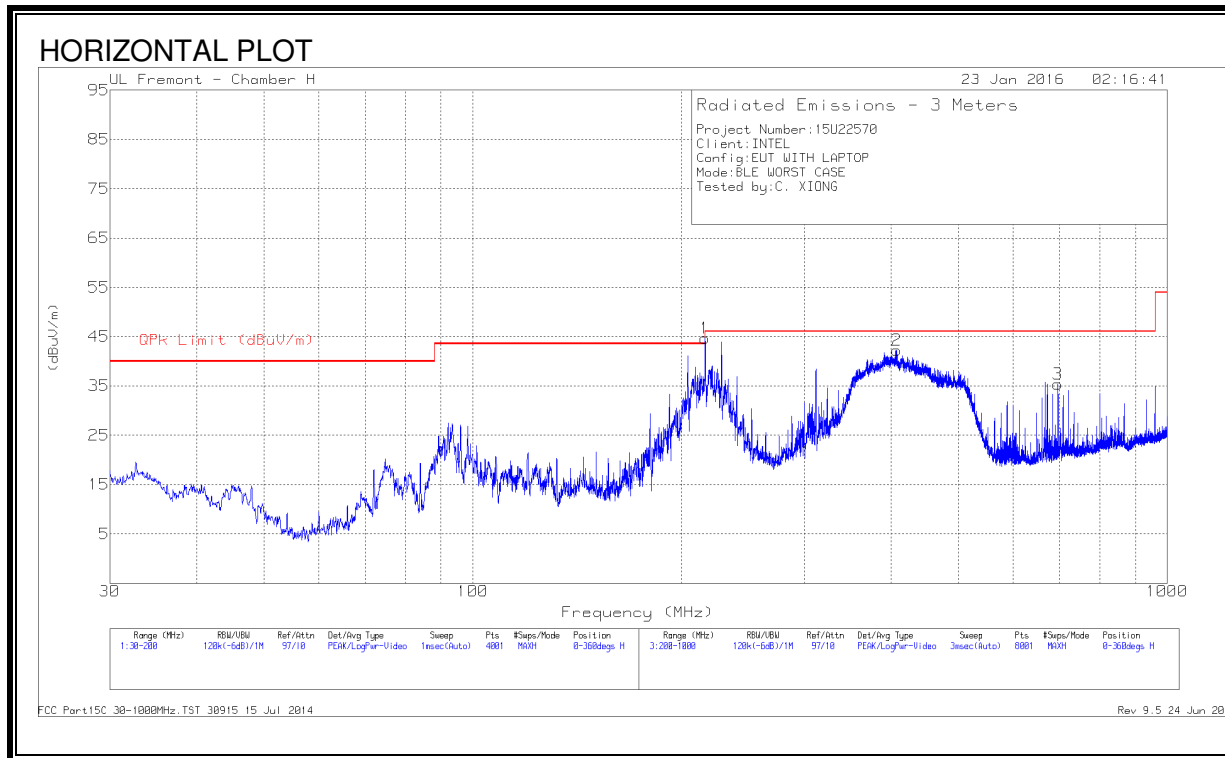

**SPURIOUS EMISSIONS 30 TO 1000 MHz (WORST-CASE CONFIGURATION, VERTICAL)**

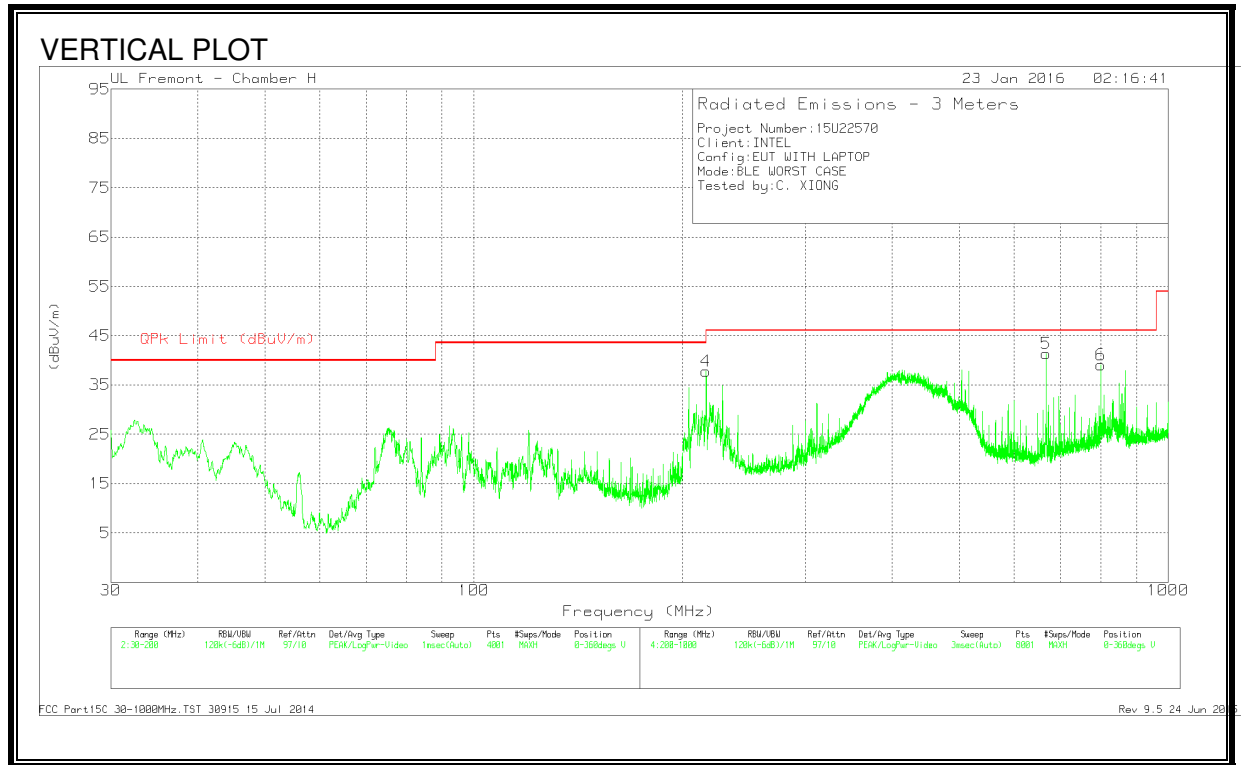

**DATA**

Marker	Frequency (MHz)	Meter Reading (dBuV)	Det	AF T900 (dB/m)	Amp/Cbl (dB)	Corrected Reading (dBuV/m)	QPk Limit (dBuV/m)	Margin (dB)	Azimuth (Degs)	Height (cm)	Polarity
2	* 405.965	51.28	Qp	15.6	-28.6	38.28	46.02	-7.74	251	103	H
1	216.0098	61.37	Qp	10.4	-29.6	42.17	46.02	-3.85	293	161	H
4	216	56.99	Pk	10.4	-29.6	37.79	43.52	-5.73	0-360	201	V
5	666.695	43.58	Qp	19.5	-27.8	35.28	46.02	-10.74	0	186	V
3	696.05	43.12	Pk	20	-27.7	35.42	46.02	-10.6	0-360	100	H
6	800	45.1	Pk	21.4	-27.4	39.1	46.02	-6.92	0-360	100	V

\* - indicates frequency in CFR15.205/IC7.2.2 Restricted Band  
 Pk - Peak detector  
 Qp - Quasi-Peak detector

### 8.4. WORST-CASE 18 – 26 GHz

#### SPURIOUS EMISSIONS 18 -26GHz (WORST-CASE CONFIGURATION)

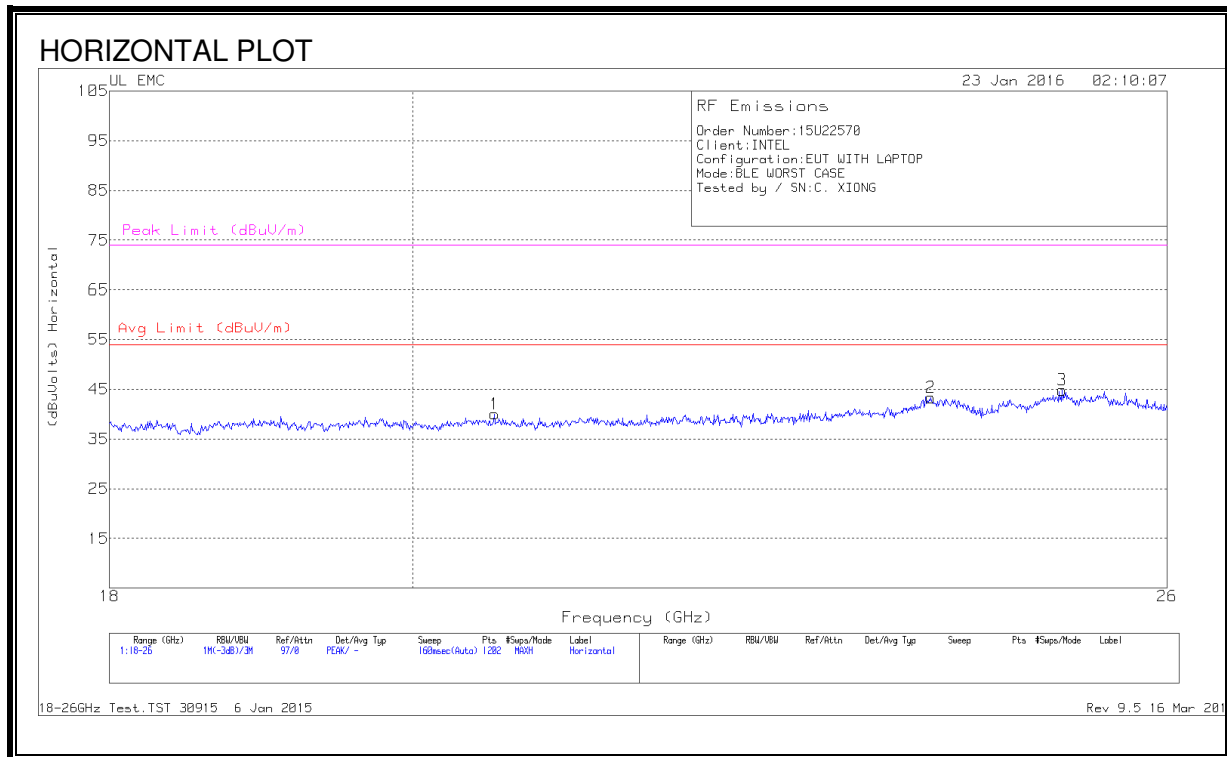

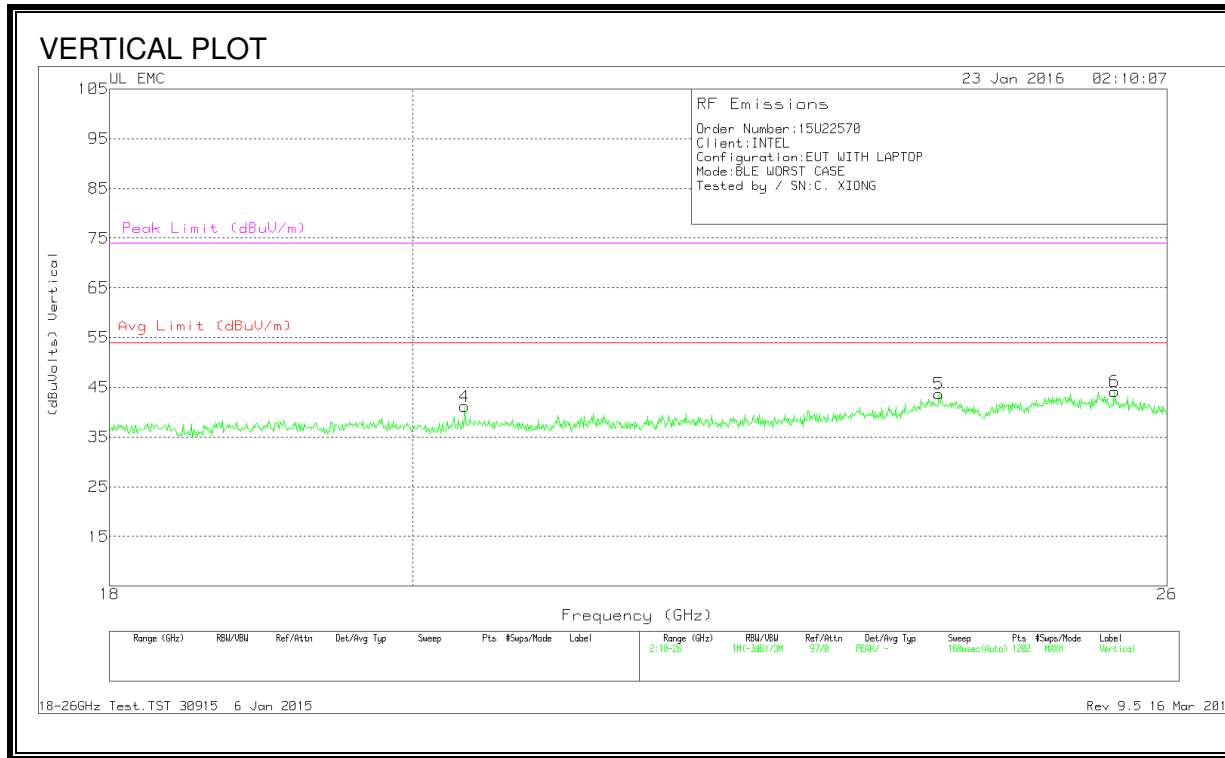

**DATA**

Marker	Frequency (GHz)	Meter Reading (dBuV)	Det	T477 AF (dB/m)	Amp/Cbl (dB)	Dist Corr (dB)	Corrected Reading (dBuVolts)	Avg Limit (dBuV/m)	Margin (dB)	Peak Limit (dBuV/m)	PK Margin (dB)
1	20.578	41.8	Pk	33.1	-25.4	-9.5	40	54	-14	74	-34
2	23.948	43.43	Pk	33.7	-24.3	-9.5	43.33	54	-10.66	74	-30.67
3	25.067	45.03	Pk	34.1	-24.8	-9.5	44.83	54	-9.16	74	-29.16
4	20.365	43.07	Pk	32.8	-25.2	-9.5	41.16	54	-12.83	74	-32.83
5	24.015	43.87	Pk	33.6	-24.3	-9.5	43.66	54	-10.33	74	-30.33
6	25.527	44.57	Pk	34.2	-25.1	-9.5	44.16	54	-9.83	74	-29.83

Pk - Peak detector

## 8.5. AC POWER LINE CONDUCTED EMISSIONS

### LIMITS

FCC §15.207 (a)

RSS-Gen 8.8

Frequency of Emission (MHz)	Conducted Limit (dB $\mu$ V)	
	Quasi-peak	Average
0.15-0.5	66 to 56 *	56 to 46 *
0.5-5	56	46
5-30	60	50

\*Decreases with the logarithm of the frequency.

### TEST PROCEDURE

The EUT is placed on a non-conducting table 40 cm from the vertical ground plane and 80 cm above the horizontal ground plane. The EUT is configured in accordance with ANSI C63.10-2013

The receiver is set to a resolution bandwidth of 9 kHz. Peak detection is used unless otherwise noted as quasi-peak or average.

Line conducted data is recorded for both NEUTRAL and HOT lines

**LINE 1 RESULTS**

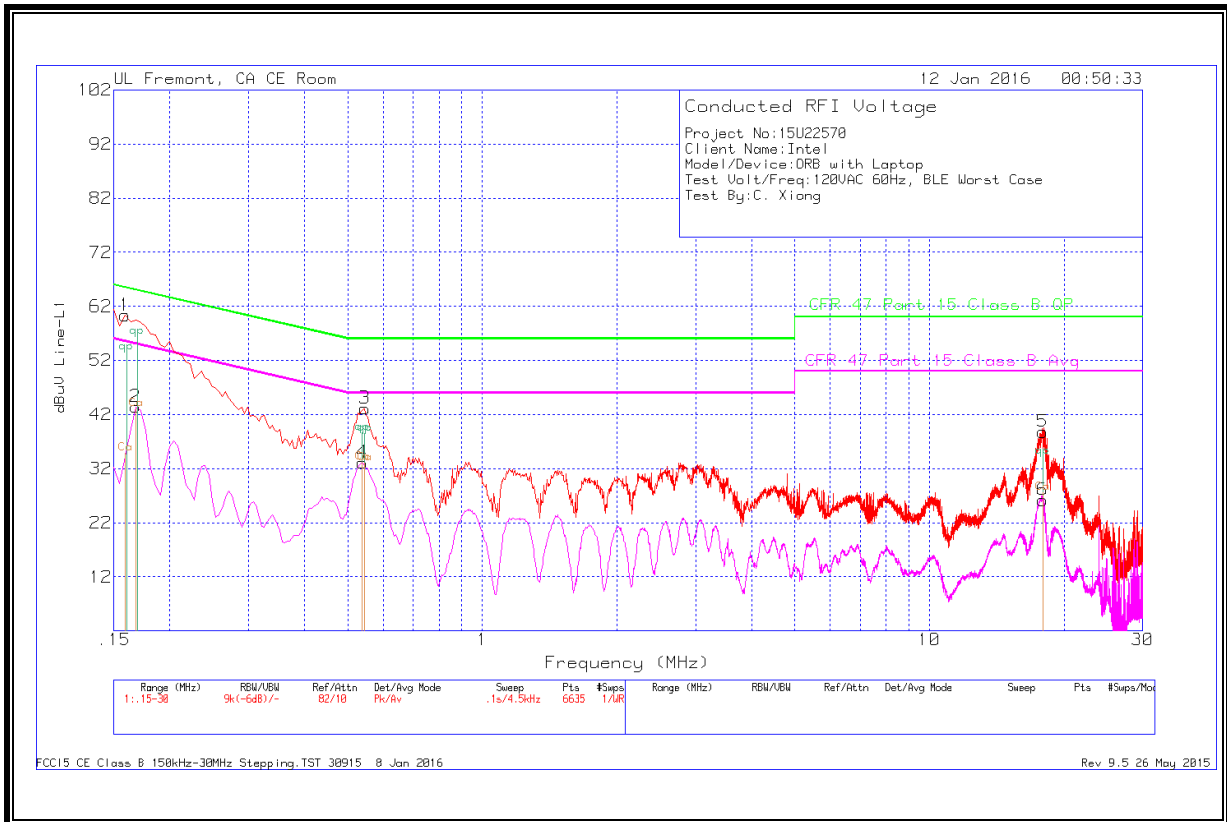



**DATA**

Range 1: Line-L1 .15 - 30MHz

Frequency (MHz)	Meter Reading (dBuV)	Det	T1310 IL L1	LC Cables 1&3	Corrected Reading dBuV	CFR 47 Part 15 Class B QP	Margin (dB)	CFR 47 Part 15 Class B Avg	Margin (dB)
.16013	34.85	Ca	0	0	34.85	-	-	55.46	-20.61
.16013	53.51	Qp	0	0	53.51	65.46	-11.95	-	-
.16913	43.06	Ca	0	0	43.06	-	-	55	-11.94
.16913	56.43	Qp	0	0	56.43	65	-8.57	-	-
.54578	32.97	Ca	0	0	32.97	-	-	46	-13.03
.54578	38.51	Qp	0	0	38.51	56	-17.49	-	-
.53903	33.15	Ca	0	0	33.15	-	-	46	-12.85
.53903	38.68	Qp	0	0	38.68	56	-17.32	-	-
17.9302	27.37	Ca	0	.2	27.57	-	-	50	-22.43
17.9302	34	Qp	0	.2	34.2	60	-25.8	-	-

Ca - CISPR average detection  
 Qp - Quasi-Peak detector

**LINE 2 RESULTS**

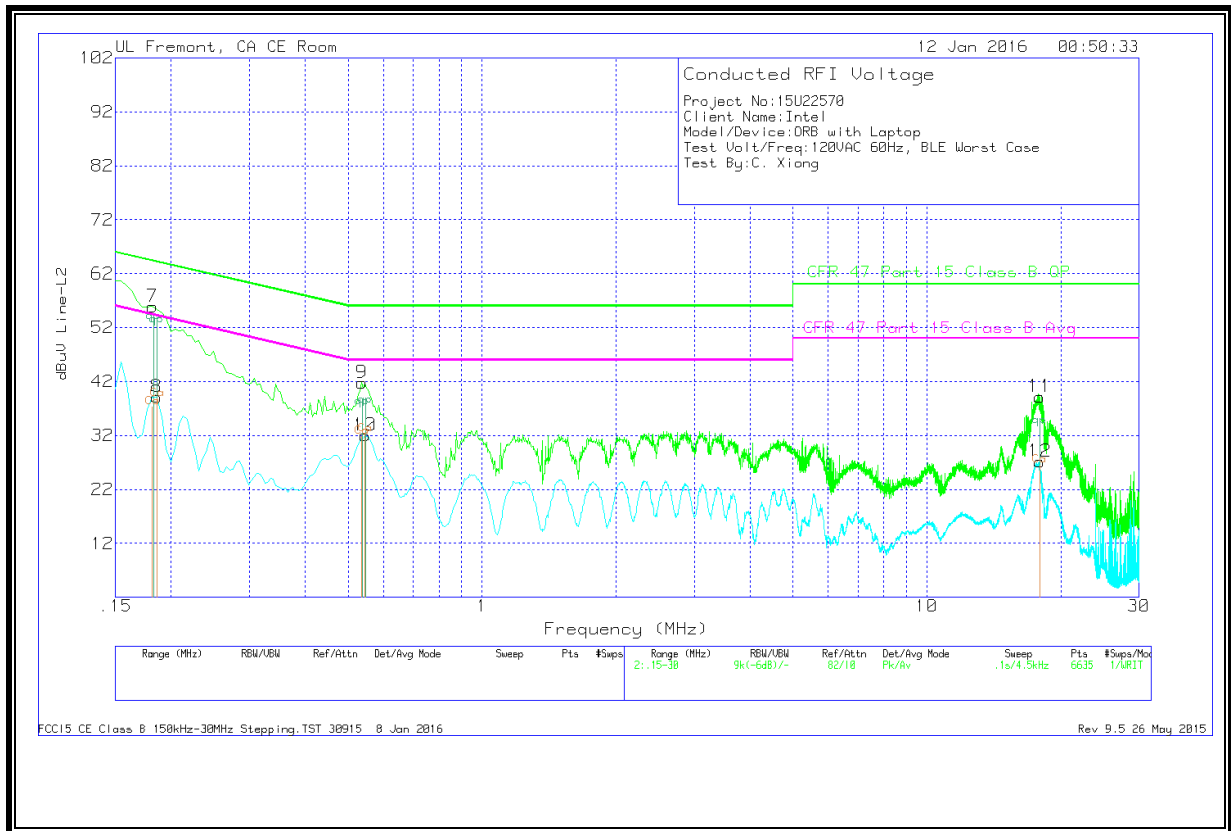

**DATA**

Range 1: Line-L1 .15 - 30MHz

Frequency (MHz)	Meter Reading (dBuV)	Det	T1310 IL L1	LC Cables 1&3	Corrected Reading dBuV	CFR 47 Part 15 Class B QP	Margin (dB)	CFR 47 Part 15 Class B Avg	Margin (dB)
.18263	37.23	Ca	0	0	37.23	-	-	54.37	-17.14
.18263	53.13	Qp	0	0	53.13	64.37	-11.24	-	-
.18578	38.79	Ca	0	0	38.79	-	-	54.22	-15.43
.18578	52.49	Qp	0	0	52.49	64.22	-11.73	-	-
.53768	31.86	Ca	0	0	31.86	-	-	46	-14.14
.53768	37.34	Qp	0	0	37.34	56	-18.66	-	-
.54668	32.22	Ca	0	0	32.22	-	-	46	-13.78
.54668	37.54	Qp	0	0	37.54	56	-18.46	-	-
17.9441	26.27	Ca	0	.2	26.47	-	-	50	-23.53
17.9441	33.55	Qp	0	.2	33.75	60	-26.25	-	-

Ca - CISPR average detection  
 Qp - Quasi-Peak detector