



**FCC 47 CFR PART 15 SUBPART C  
INDUSTRY CANADA RSS-247 ISSUE 1**

**BLUETOOTH LOW ENERGY  
CERTIFICATION TEST REPORT**

**FOR**

**SMART WATCH WITH 802.11B/G/N, BLUETOOTH AND BLE**

**MODEL NUMBER: DW1**

**FCC ID: 2AB8ZND10**

**IC: 1000X-ND10**

**REPORT NUMBER: 15U21900-E2V1**

**ISSUE DATE: OCTOBER 19, 2015**

*Prepared for*  
**INTEL CORPORATION  
2200 MISSION COLLEGE BOULEVARD,  
SANTA CLARA, CA 95052, U.S.A**

*Prepared by*  
**UL VERIFICATION SERVICES INC.  
47173 BENICIA STREET  
FREMONT, CA 94538, U.S.A.  
TEL: (510) 771-1000  
FAX: (510) 661-0888**



**NVLAP LAB CODE 200065-0**

Revision History

<u>Rev.</u>	<u>Issue Date</u>	<u>Revisions</u>	<u>Revised By</u>
V1	10/19/2015	Initial Issue	C. Pang
V2	10/22/2015	Updated antenna gain in section 5.3	C. Susa

## TABLE OF CONTENTS

<b>1. ATTESTATION OF TEST RESULTS .....</b>	<b>5</b>
<b>2. TEST METHODOLOGY .....</b>	<b>6</b>
<b>3. FACILITIES AND ACCREDITATION .....</b>	<b>6</b>
<b>4. CALIBRATION AND UNCERTAINTY .....</b>	<b>6</b>
4.1. <i>MEASURING INSTRUMENT CALIBRATION .....</i>	<i>6</i>
4.2. <i>SAMPLE CALCULATION .....</i>	<i>6</i>
4.3. <i>MEASUREMENT UNCERTAINTY.....</i>	<i>7</i>
<b>5. EQUIPMENT UNDER TEST .....</b>	<b>8</b>
5.1. <i>DESCRIPTION OF EUT .....</i>	<i>8</i>
5.2. <i>MAXIMUM OUTPUT POWER.....</i>	<i>8</i>
5.3. <i>DESCRIPTION OF AVAILABLE ANTENNAS .....</i>	<i>8</i>
5.4. <i>SOFTWARE AND FIRMWARE.....</i>	<i>8</i>
5.5. <i>WORST-CASE CONFIGURATION AND MODE.....</i>	<i>8</i>
5.6. <i>DESCRIPTION OF TEST SETUP.....</i>	<i>9</i>
<b>6. TEST AND MEASUREMENT EQUIPMENT .....</b>	<b>14</b>
<b>7. ANTENNA PORT TEST RESULTS .....</b>	<b>15</b>
7.1. <i>MEASUREMENT METHODS .....</i>	<i>15</i>
7.2. <i>ON TIME, DUTY CYCLE .....</i>	<i>16</i>
7.3. <i>6 dB BANDWIDTH.....</i>	<i>17</i>
7.4. <i>99% BANDWIDTH.....</i>	<i>20</i>
7.5. <i>OUTPUT POWER.....</i>	<i>23</i>
7.6. <i>AVERAGE POWER.....</i>	<i>26</i>
7.7. <i>POWER SPECTRAL DENSITY.....</i>	<i>27</i>
7.8. <i>CONDUCTED SPURIOUS EMISSIONS.....</i>	<i>30</i>
<b>8. RADIATED TEST RESULTS.....</b>	<b>34</b>
8.1. <i>LIMITS AND PROCEDURE.....</i>	<i>34</i>
8.2. <i>TRANSMITTER ABOVE 1 GHz.....</i>	<i>35</i>
8.3. <i>WORST-CASE BELOW 1 GHz.....</i>	<i>45</i>
<b>9. AC POWER LINE CONDUCTED EMISSIONS .....</b>	<b>47</b>
9.1. <i>EUT WITH AC ADAPTER.....</i>	<i>48</i>
9.2. <i>EUT WITH USB LAPTOP .....</i>	<i>51</i>

**10. SETUP PHOTOS .....53**

# 1. ATTESTATION OF TEST RESULTS

**COMPANY NAME:** INTEL CORPORATION  
2200 MISSION COLLEGE BOULEVARD  
SANTA CLARA, CA 95052, U.S.A.

**EUT DESCRIPTION:** SMART WATCH with 802.11b/g/n, Bluetooth and BLE

**MODEL:** DW1

**SERIAL NUMBER:** TIDPC3FZ52800CH (Radiated); TIDPC1FZ536009X (Conducted)

**DATE TESTED:** OCTOBER 15 – 19, 2015

APPLICABLE STANDARDS	
STANDARD	TEST RESULTS
CFR 47 Part 15 Subpart C	Pass
INDUSTRY CANADA RSS-247 Issue 1	Pass
INDUSTRY CANADA RSS-GEN Issue 4	Pass

UL Verification Services Inc. tested the above equipment in accordance with the requirements set forth in the above standards. All indications of Pass/Fail in this report are opinions expressed by UL Verification Services Inc. based on interpretations and/or observations of test results. Measurement Uncertainties were not taken into account and are published for informational purposes only. The test results show that the equipment tested is capable of demonstrating compliance with the requirements as documented in this report.

**Note:** The results documented in this report apply only to the tested sample, under the conditions and modes of operation as described herein. This document may not be altered or revised in any way unless done so by UL Verification Services Inc. and all revisions are duly noted in the revisions section. Any alteration of this document not carried out by UL Verification Services Inc. will constitute fraud and shall nullify the document. This report must not be used by the client to claim product certification, approval, or endorsement by NVLAP, NIST, any agency of the Federal Government, or any agency of any government.

Approved & Released For  
UL Verification Services Inc. By:



CHIN PANG  
EMC SUPERVISOR  
UL Verification Services Inc.

Tested By:

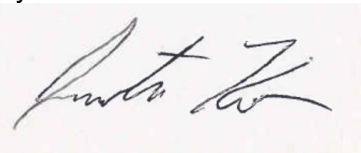

JUSTIN KO  
EMC ENGINEER  
UL Verification Services Inc.

## 2. TEST METHODOLOGY

The tests documented in this report were performed in accordance with FCC CFR 47 Part 2, FCC CFR 47 Part 15, ANSI C63.10-2013, RSS-GEN Issue 4 and RSS-247 Issue 1.

## 3. FACILITIES AND ACCREDITATION

The test sites and measurement facilities used to collect data are located at 47173 and 47266 Benicia Street, Fremont, California, USA. Line conducted emissions are measured only at the 47173 address. The following table identifies which facilities were utilized for radiated emission measurements documented in this report. Specific facilities are also identified in the test results sections.

47173 Benicia Street	47266 Benicia Street
<input type="checkbox"/> Chamber A(IC: 2324B-1)	<input checked="" type="checkbox"/> Chamber D(IC: 2324B-4)
<input type="checkbox"/> Chamber B(IC: 2324B-2)	<input type="checkbox"/> Chamber E(IC: 2324B-5)
<input checked="" type="checkbox"/> Chamber C(IC: 2324B-3)	<input type="checkbox"/> Chamber F(IC: 2324B-6)
	<input type="checkbox"/> Chamber G(IC: 2324B-7)
	<input type="checkbox"/> Chamber H(IC: 2324B-8)

The above test sites and facilities are covered under FCC Test Firm Registration # 208313. Chambers A through H are covered under Industry Canada company address code 2324B with site numbers 2324B -1 through 2324B-8, respectively.

UL Verification Services Inc. is accredited by NVLAP, Laboratory Code 200065-0. The full scope of accreditation can be viewed at <http://ts.nist.gov/standards/scopes/2000650.htm>.

## 4. CALIBRATION AND UNCERTAINTY

### 4.1. MEASURING INSTRUMENT CALIBRATION

The measuring equipment utilized to perform the tests documented in this report has been calibrated in accordance with the manufacturer's recommendations, and is traceable to recognized national standards.

### 4.2. SAMPLE CALCULATION

Where relevant, the following sample calculation is provided:

$$\begin{aligned} \text{Field Strength (dBuV/m)} &= \text{Measured Voltage (dBuV)} + \text{Antenna Factor (dB/m)} + \\ &\text{Cable Loss (dB)} - \text{Preamp Gain (dB)} \\ 36.5 \text{ dBuV} + 18.7 \text{ dB/m} + 0.6 \text{ dB} - 26.9 \text{ dB} &= 28.9 \text{ dBuV/m} \end{aligned}$$

### 4.3. MEASUREMENT UNCERTAINTY

Where relevant, the following measurement uncertainty levels have been estimated for tests performed on the apparatus:

PARAMETER	UNCERTAINTY
Conducted Disturbance, 0.15 to 30 MHz	$\pm 3.52$ dB
Radiated Disturbance, 30 to 1000 MHz	$\pm 4.94$ dB
Radiated Disturbance, 1 to 6 GHz	$\pm 3.86$ dB
Radiated Disturbance, 6 to 18 GHz	$\pm 4.23$ dB
Radiated Disturbance, 18 to 26 GHz	$\pm 5.30$ dB
Radiated Disturbance, 26 to 40 GHz	$\pm 5.23$ dB

Uncertainty figures are valid to a confidence level of 95%.

## 5. EQUIPMENT UNDER TEST

### 5.1. DESCRIPTION OF EUT

The EUT is a smart watch with SMART WATCH with 802.11b/g/n, Bluetooth and BLE

### 5.2. MAXIMUM OUTPUT POWER

The transmitter has a maximum peak conducted output power as follows:

Frequency Range (MHz)	Mode	Output Power (dBm)	Output Power (mW)
2402 - 2480	BLE	9.96	9.91

### 5.3. DESCRIPTION OF AVAILABLE ANTENNAS

The radio utilizes a trace antenna, with a maximum gain of -0.84 dBi.

### 5.4. SOFTWARE AND FIRMWARE

The firmware installed in the EUT during testing was DVT Eng. Build.

### 5.5. WORST-CASE CONFIGURATION AND MODE

Radiated emission and power line conducted emission were performed with the EUT set to transmit at the channel with highest output power as worst-case scenario.

The fundamental of the EUT was investigated in three orthogonal orientations X, Y and Z, it was determined that Z orientation was worst-case orientation; therefore, all final radiated testing was performed with the EUT in Z orientation.

Based on the baseline scan, the worst-case data rates were:

BLE: 1 Mbps.



## 5.6. DESCRIPTION OF TEST SETUP

### SUPPORT EQUIPMENT

Support Equipment List				
Description	Manufacturer	Model	Serial Number	FCC ID
Laptop	Lenovo	Yoga 2 11	YB04282152	N/A
AC adapter	Lenovo	ADLX45NCC3A	11S45N0297Z1ZSH443G0XE	N/A

### I/O CABLES

I/O Cable List						
Cable No	Port	# of identical ports	Connector Type	Cable Type	Cable Length (m)	Remarks
1	AC	1	3-Prong	Un-Shielded	1.8	N/A
2	DC	1	DC	Un-Shielded	1	N/A
3	USB	1	USB	Un-Shielded	0.9	Laptop to EUT
4	Antenna	1	SMA	Shielded	0.3	EUT to spectrum Analyzer
5	AC/DC	1	USB Micro	Un-Shielded	0.9	

### TEST SETUP

Test software exercised the radio card.

**SETUP DIAGRAM FOR CONDUCTED TESTS**

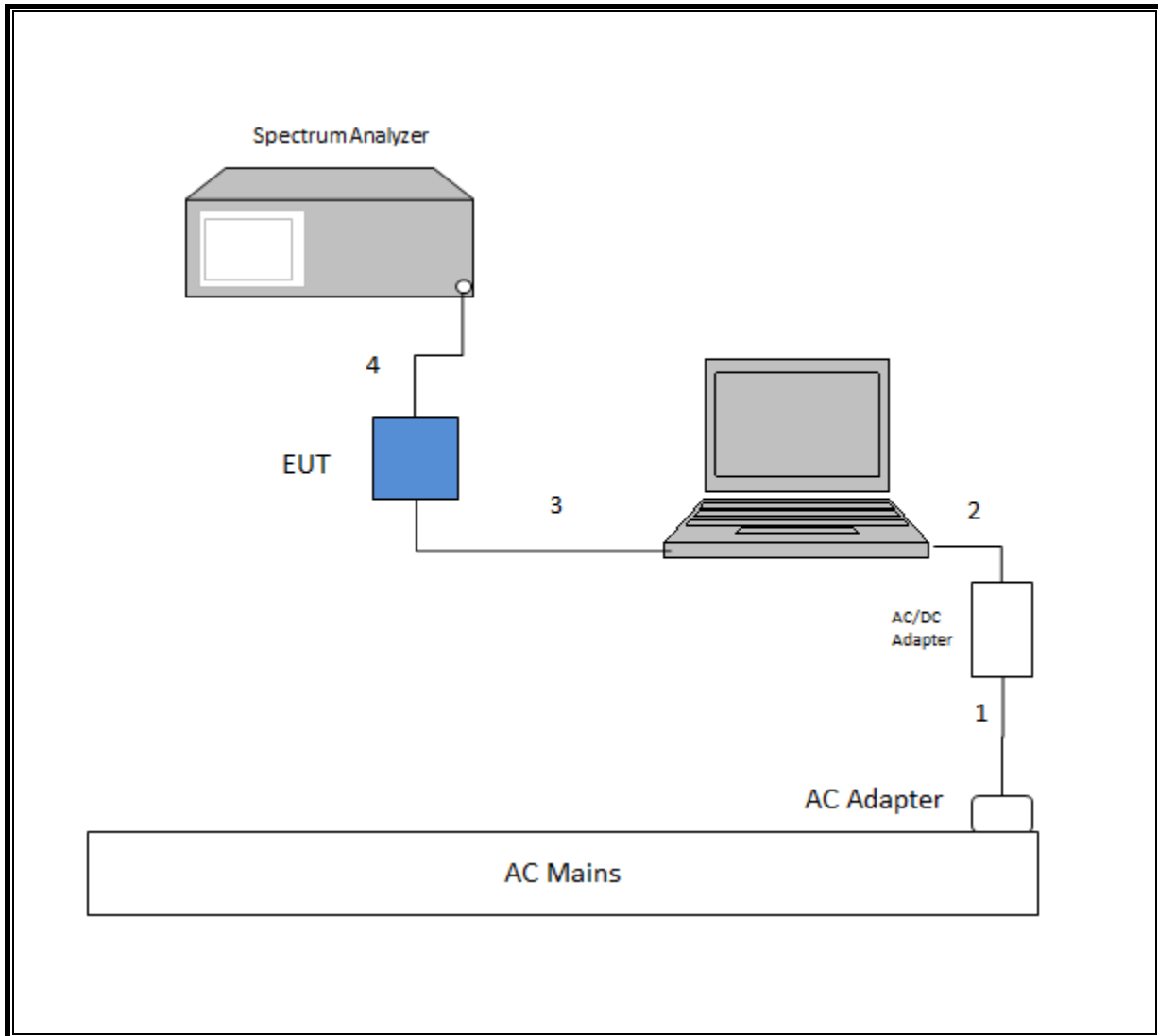

**SETUP DIAGRAM FOR RADIATED TESTS**

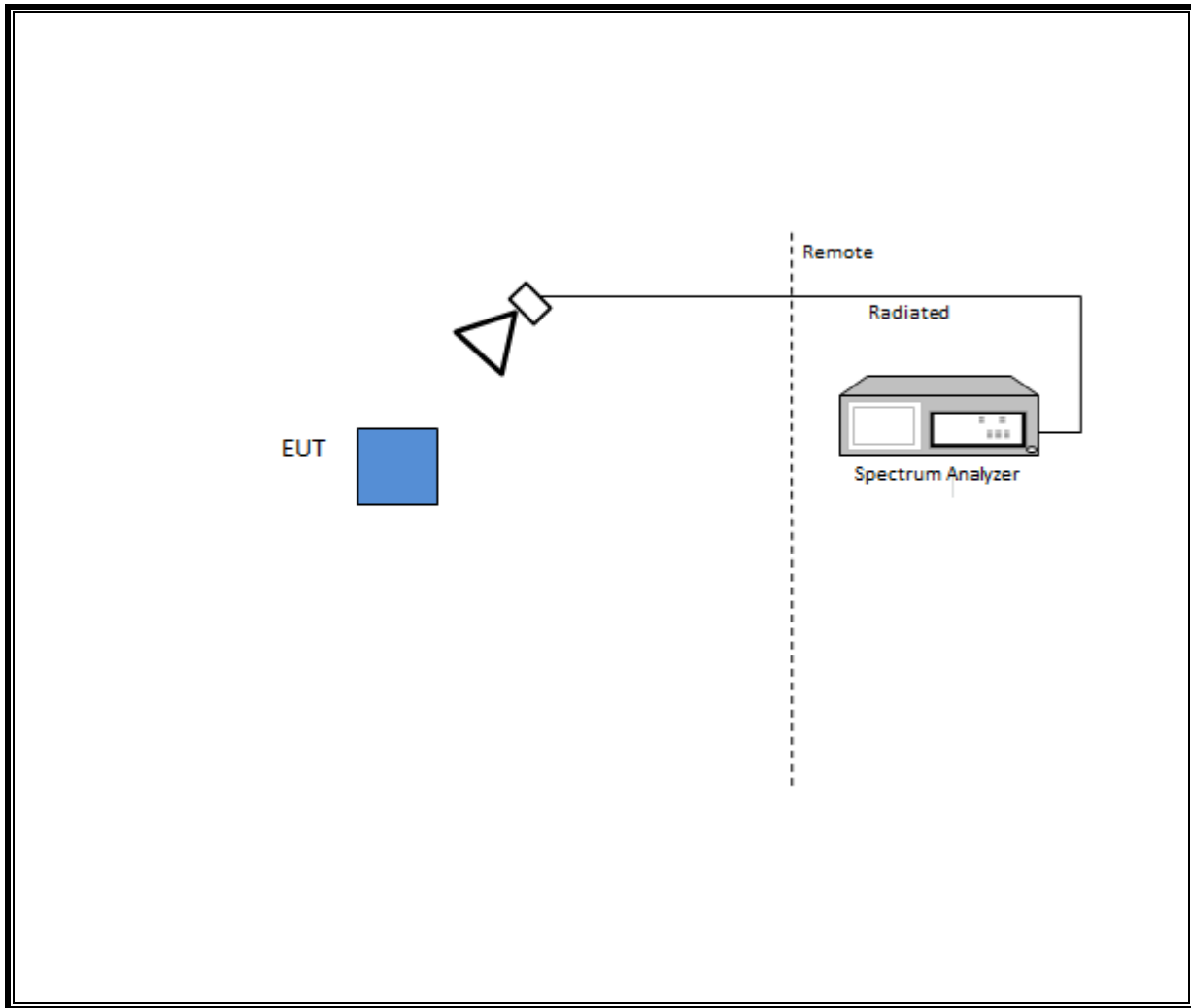

**SETUP DIAGRAM 1 FOR LINE CONDUCTED TEST**

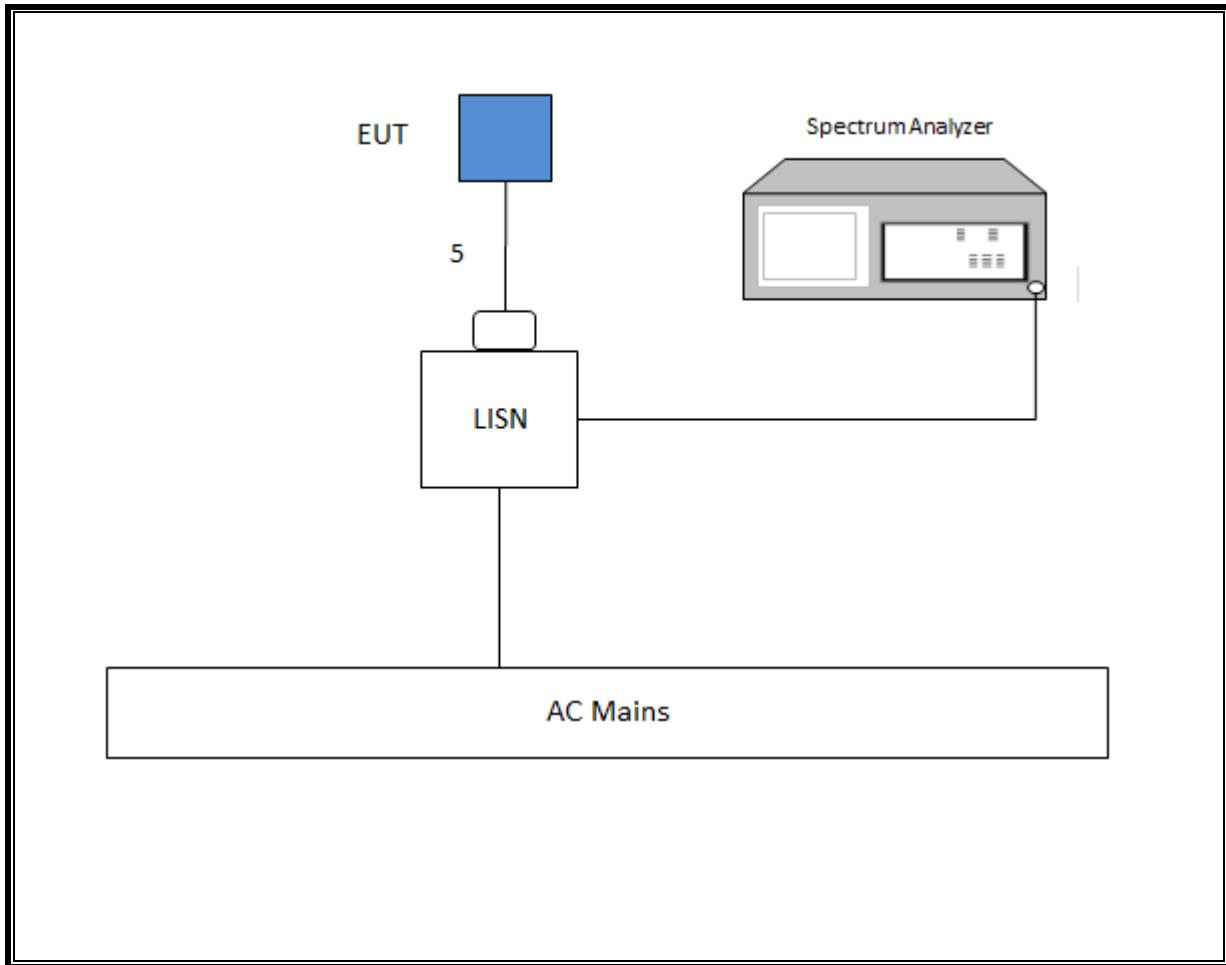

**SETUP DIAGRAM 2 FOR LINE CONDUCTED TEST**

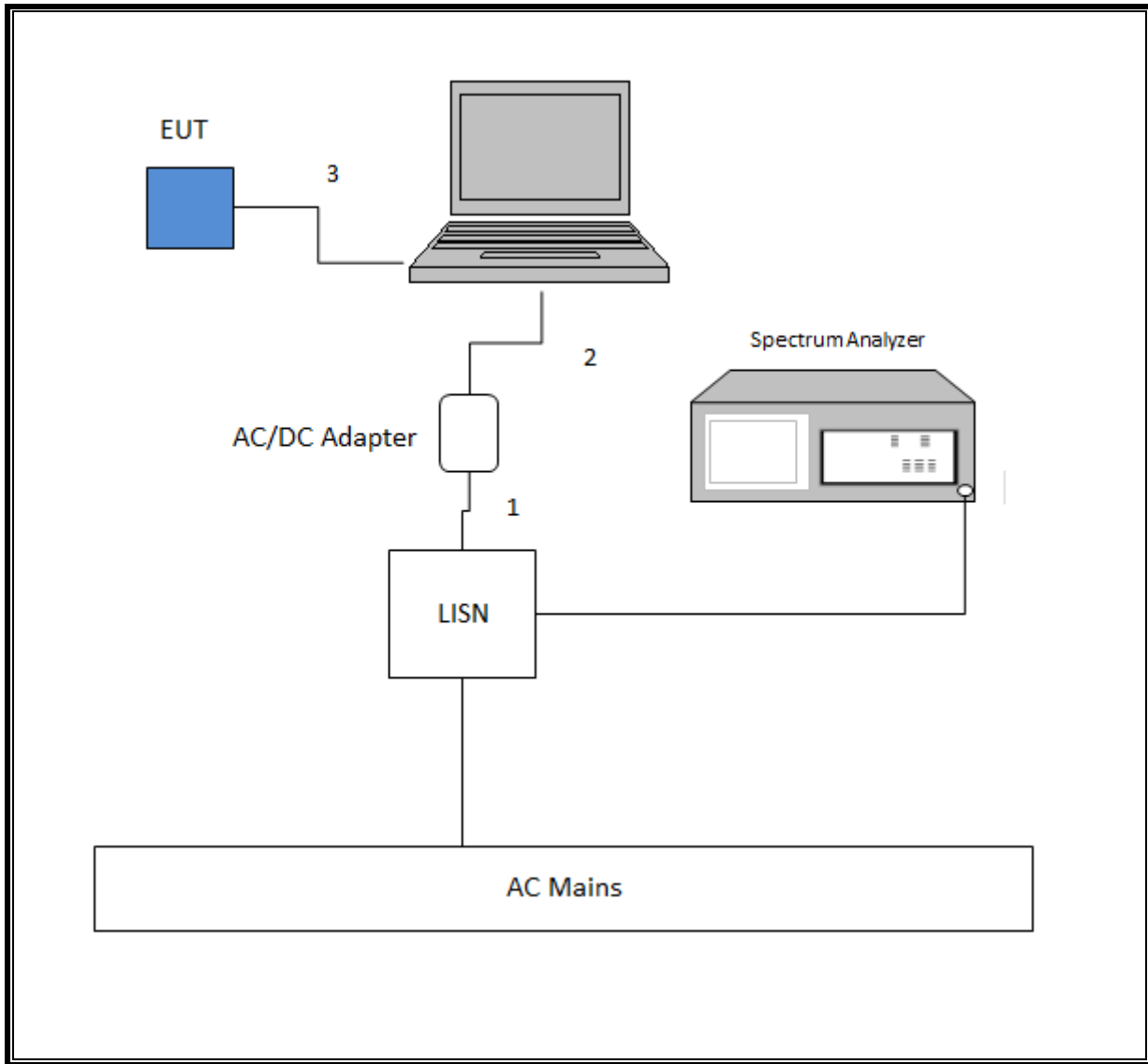

## 6. TEST AND MEASUREMENT EQUIPMENT

The following test and measurement equipment was utilized for the tests documented in this report:

Test Equipment List					
Description	Manufacturer	Model	T No.	Cal Date	Cal Due
Radiated Software	UL	UL EMC		Ver 9.5	
Conducted Software	UL	UL EMC		Ver 3.5	
Spectrum Analyzer, PSA, 3Hz to 44GHz	Keysight	N9030A	907	05/15/15	01/07/16
Antenna, Horn, 1-18GHz	ETS Lindgren	3117	345	03/03/15	03/03/16
Antenna, Broadband Hybrid, 30 to 2000MHz	Sunol Sciences	JB1	899	4/30/2015	4/30/2016
Amplifier, 1-18GHz	Miteq	AFS42-00101800-25-S-42	493	01/16/15	01/16/16
Filter, HPF 3.0GHz	Micro-Tronics	HPM17543	485	01/16/15	01/16/16
Spectrum Analyzer, PSA, 3Hz to 44GHz	Keysight	N9030A	342	06/29/15	06/29/16
Spectrum Analyzer, PSA, 3Hz to 44GHz	Keysight	N9030A	905	6/16/2015	5/26/2016
Amplifier, 10kHz to 1GHz	Sonoma	310N	834	6/8/2015	6/8/2016
Power Meter	Keysight	N1911A	1244	07/02/15	07/02/16
Power Sensor	Keysight	N1921A	1228	07/06/15	07/06/16
EMI Test Receiver 9Khz-7GHz	Rohde & Schwarz	ESC17	100935	08/07/15	08/07/16
LISN for Conducted Emissions CISPR-16	FCC	50/250-25-2	114	01/16/15	01/16/16

## 7. ANTENNA PORT TEST RESULTS

### 7.1. MEASUREMENT METHODS

6 dB BW: KDB 558074 D01 v03r03, Section 8.1.

Output Power: KDB 558074 D01 v03r03, Section 9.1.2.

Power Spectral Density: KDB 558074 D01 v03r03, Section 10.2.

Out-of-band emissions in non-restricted bands: KDB 558074 D01 v03r03, Section 11.0.

Out-of-band emissions in restricted bands: KDB 558074 D01 v03r03, Section 12.1.

Band-edge: KDB 558074 D01 v03r03, Section 12.1

## 7.2. ON TIME, DUTY CYCLE

None; for reporting purposes only.

### PROCEDURE

KDB 558074 Zero-Span Spectrum Analyzer Method.

### ON TIME AND DUTY CYCLE RESULTS

Mode	ON Time B (msec)	Period (msec)	Duty Cycle x (linear)	Duty Cycle (%)	Duty Cycle Correction Factor (dB)	1/B Minimum VBW (kHz)
BLE	0.389	0.625	0.623	62.27%	2.06	2.571

### DUTY CYCLE PLOTS

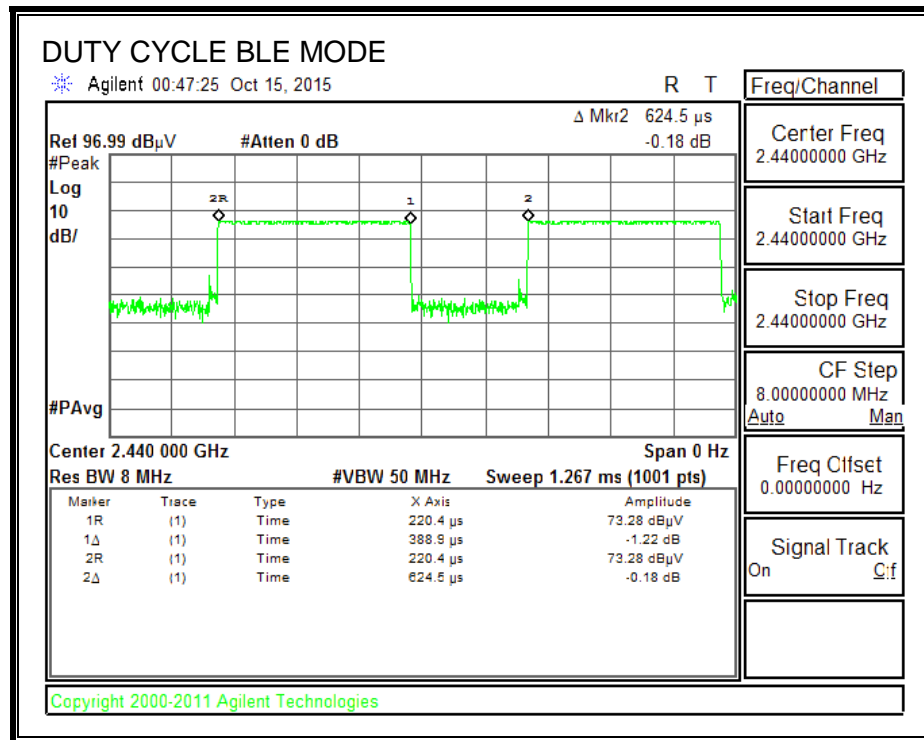



### 7.3. 6 dB BANDWIDTH

#### LIMITS

FCC §15.247 (a) (2)

IC RSS-247 (5.2) (1)

The minimum 6 dB bandwidth shall be at least 500 kHz.

#### RESULTS

Channel	Frequency (MHz)	6 dB Bandwidth (MHz)	Minimum Limit (MHz)
Low	2402	0.680	0.5
Middle	2440	0.690	0.5
High	2480	0.684	0.5

**6 dB BANDWIDTH**

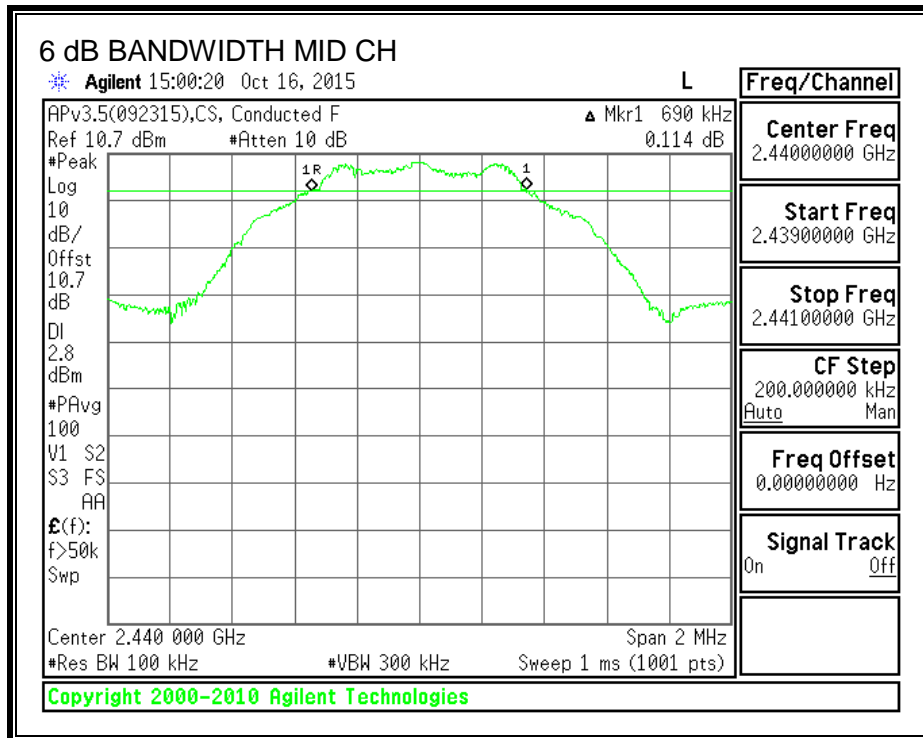
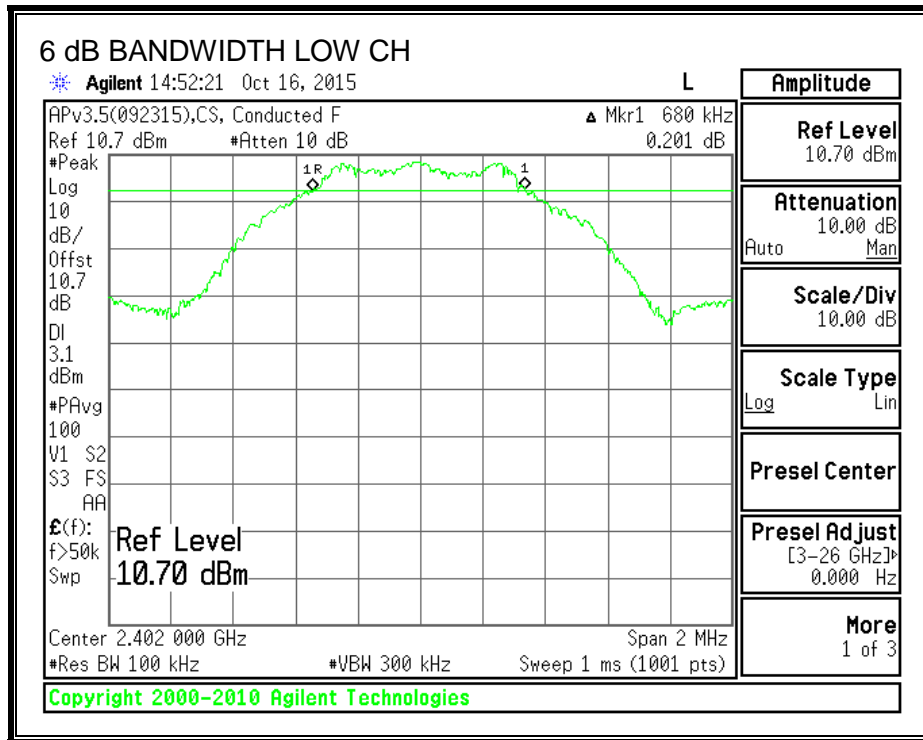

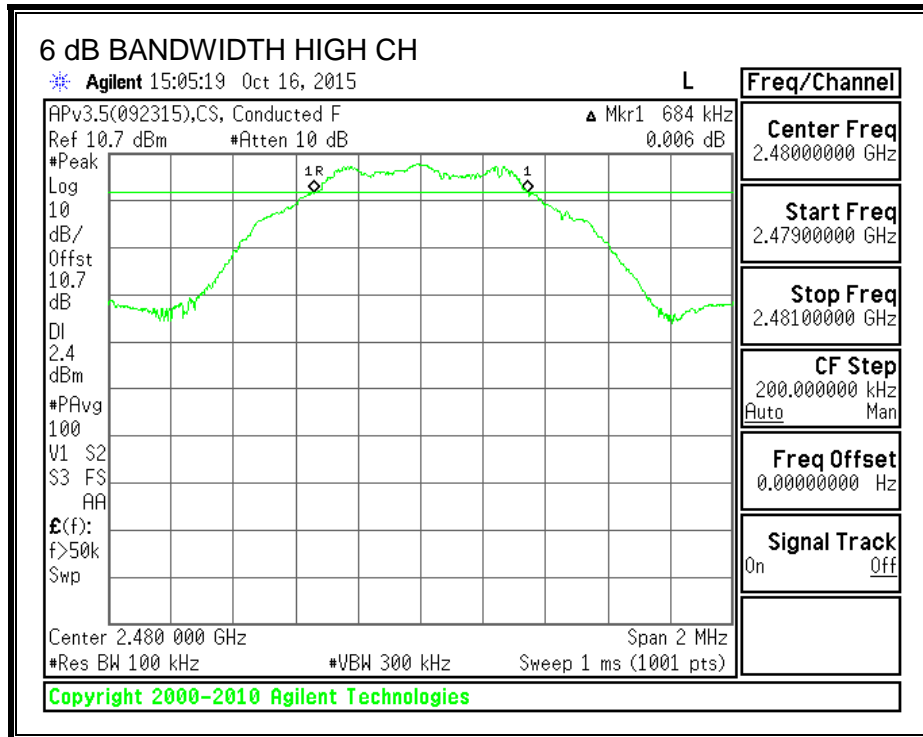

## 7.4. 99% BANDWIDTH

### LIMITS

None; for reporting purposes only.

### TEST PROCEDURE

The transmitter output is connected to the spectrum analyzer. The RBW is set to 1% to 3% of the 99 % bandwidth and to 1% of the span. The VBW is set to 3 times the RBW. The sweep time is coupled. The spectrum analyzer internal 99% bandwidth function is utilized.

### RESULTS

Channel	Frequency (MHz)	99% Bandwidth (MHz)
Low	2402	1.0502
Middle	2440	1.0545
High	2480	1.0542

**99% BANDWIDTH**

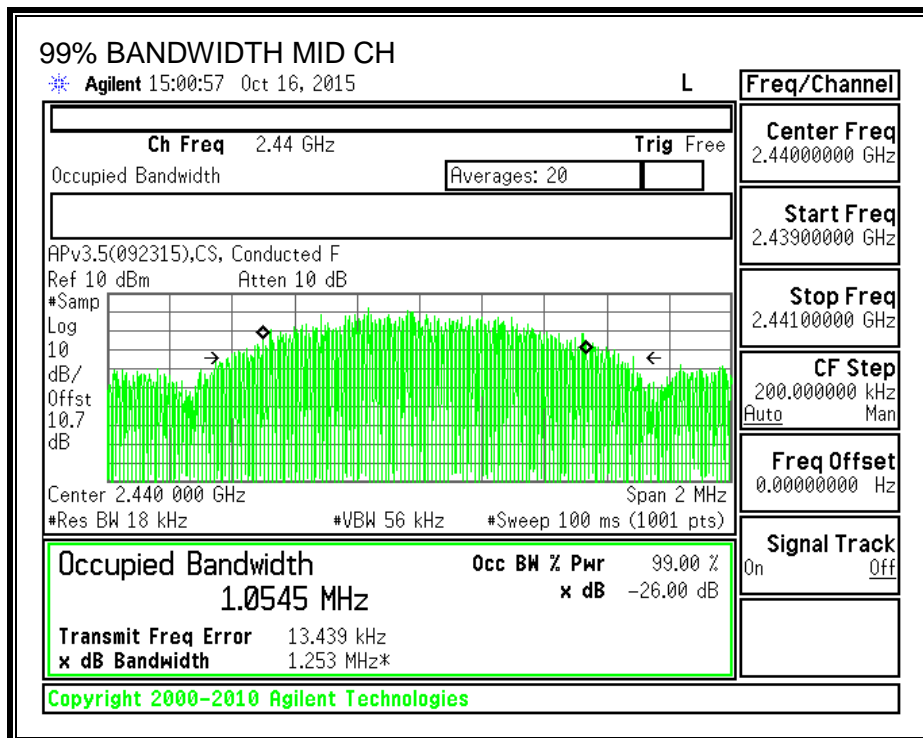
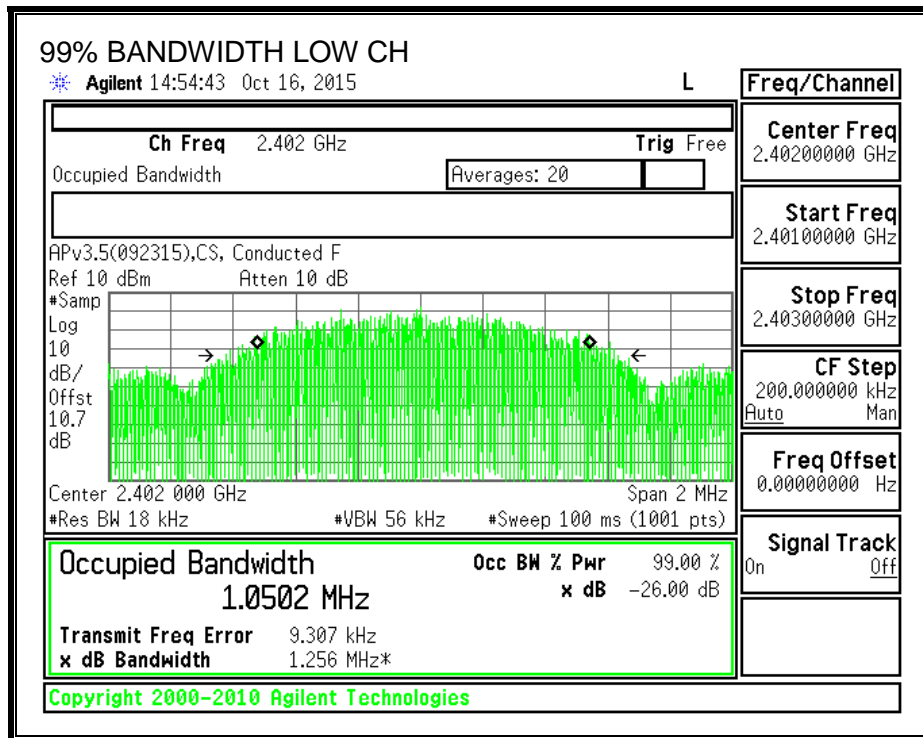

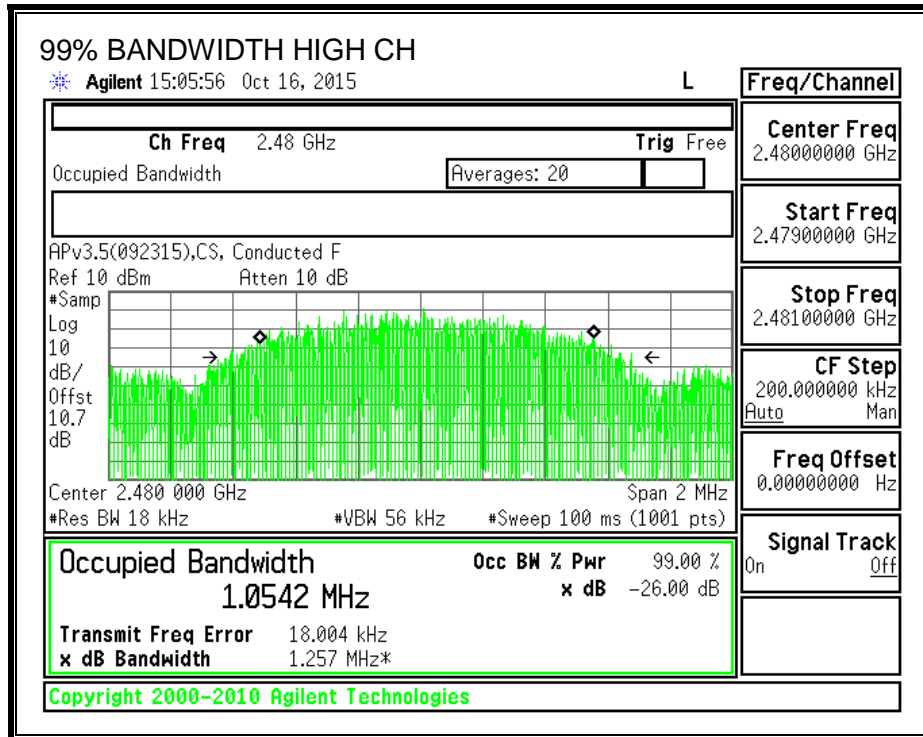

## 7.5. OUTPUT POWER

### LIMITS

FCC §15.247 (b)

IC RSS-247 (5.4) (4)

The maximum antenna gain is less than or equal to 6 dBi, therefore the limit is 30 dBm.

### RESULTS

Channel	Frequency (MHz)	Peak Power Reading (dBm)	Limit (dBm)	Margin (dB)
Low	2402	9.89	30	-20.110
Middle	2440	9.96	30	-20.040
High	2480	9.37	30	-20.630

**OUTPUT POWER**

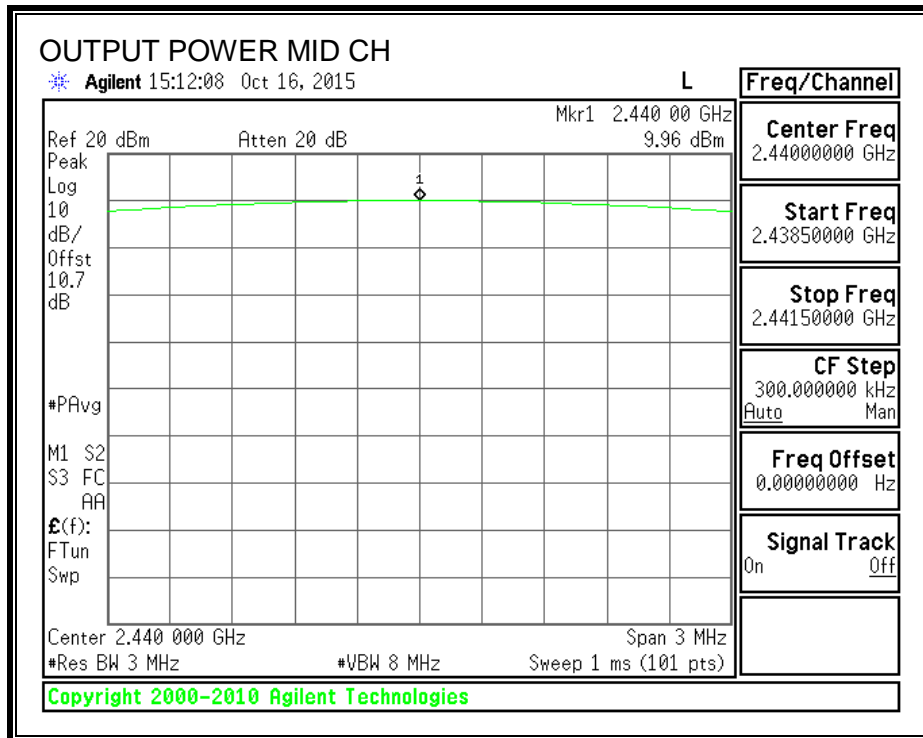
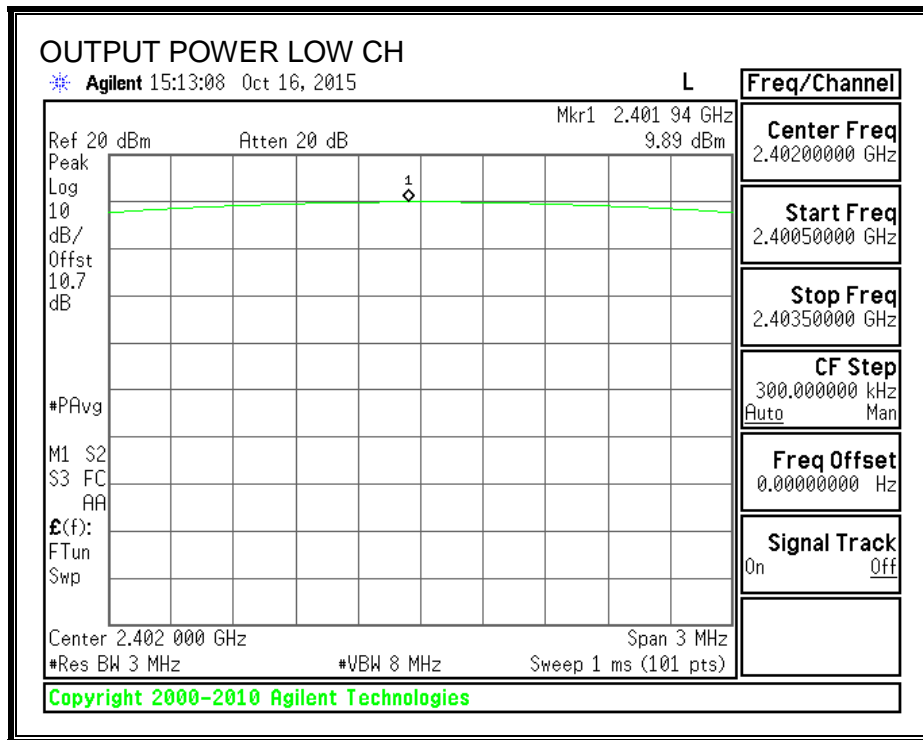



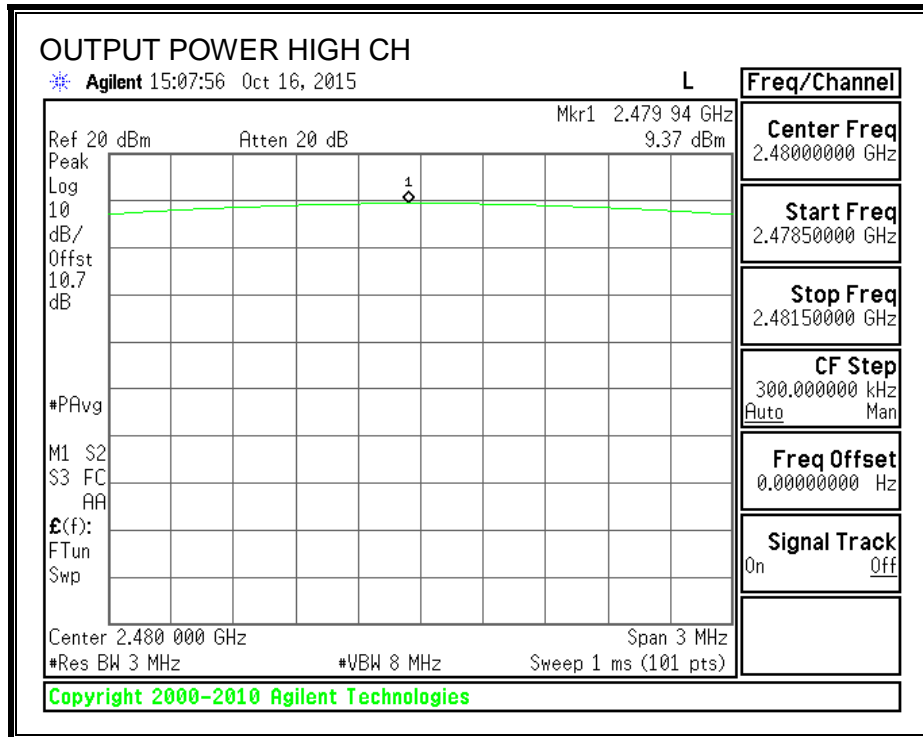

## 7.6. AVERAGE POWER

### LIMITS

None; for reporting purposes only.

### RESULTS

The cable assembly insertion loss of 10.3 dB (including 10 dB pad and 0.3 dB cable) was entered as an offset in the power meter to allow for direct reading of power.

Channel	Frequency (MHz)	AV power (dBm)
Low	2402	9.30
Middle	2440	9.20
High	2480	9.00

## 7.7. POWER SPECTRAL DENSITY

### LIMITS

FCC §15.247 (e)

IC RSS-247 (5.2) (2)

The power spectral density conducted from the transmitter to the antenna shall not be greater than 8 dBm in any 3 kHz band during any time interval of continuous transmission.

### RESULTS

Channel	Frequency (MHz)	PSD (dBm)	Limit (dBm)	Margin (dB)
Low	2402	-4.40	8	-12.40
Middle	2440	-4.37	8	-12.37
High	2480	-4.91	8	-12.91

**POWER SPECTRAL DENSITY**

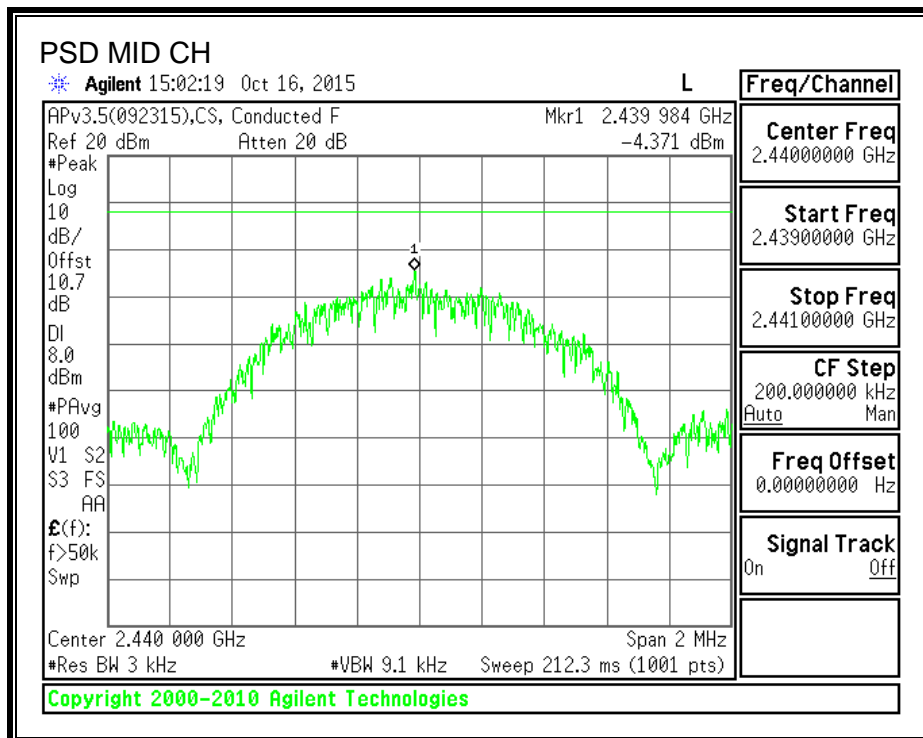
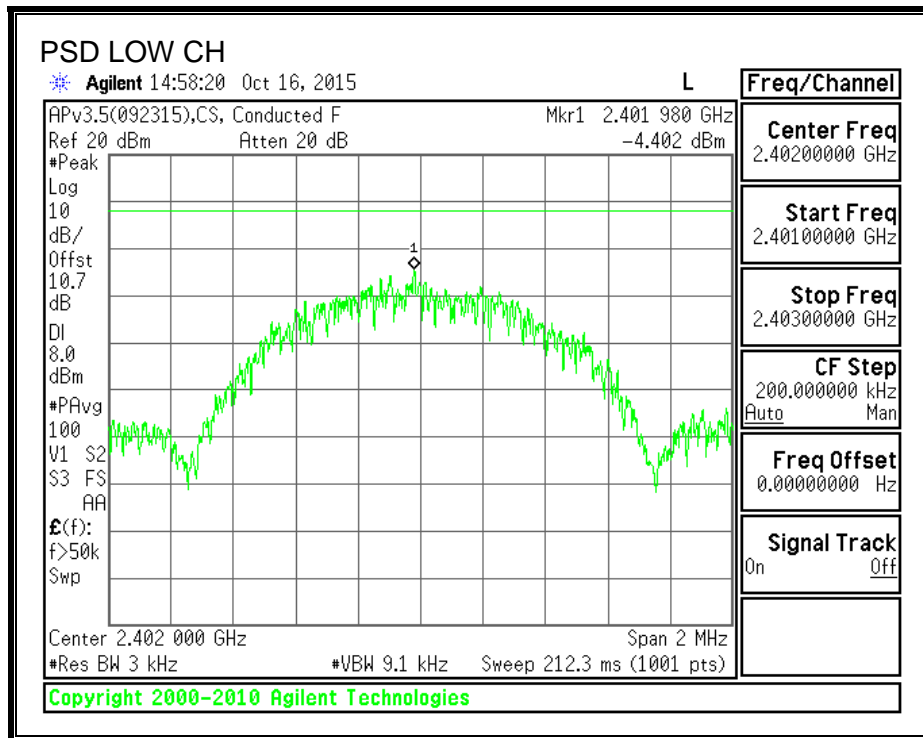

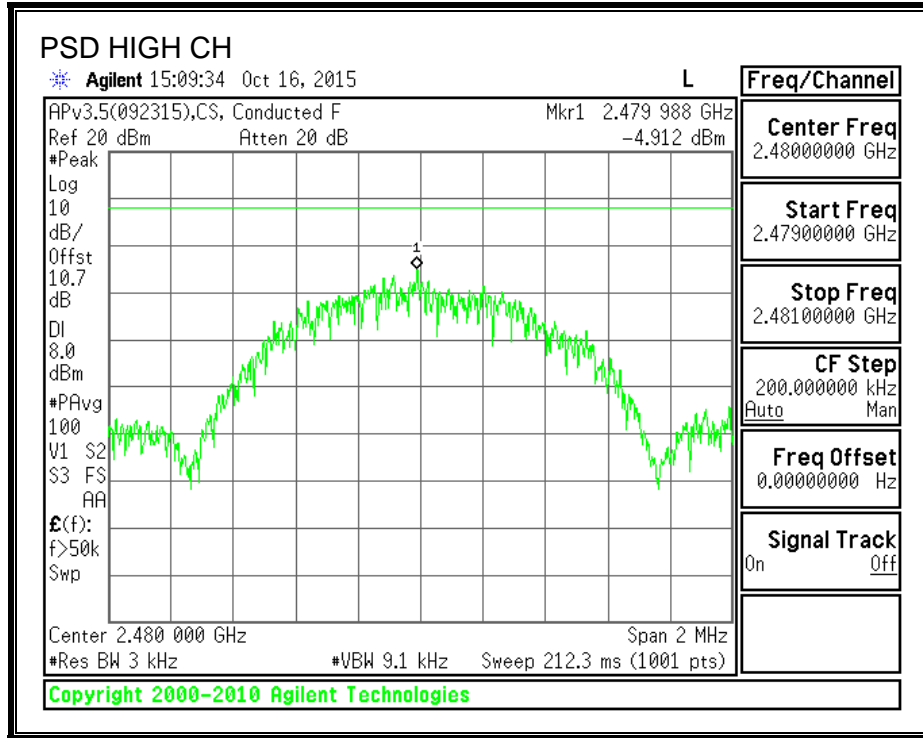

## **7.8. CONDUCTED SPURIOUS EMISSIONS**

### **LIMITS**

FCC §15.247 (d)

IC RSS-247 (5.5)

Output power was measured based on the use of a peak measurement, therefore the required attenuation is 20 dB.

### **RESULTS**

**SPURIOUS EMISSIONS, LOW CHANNEL**

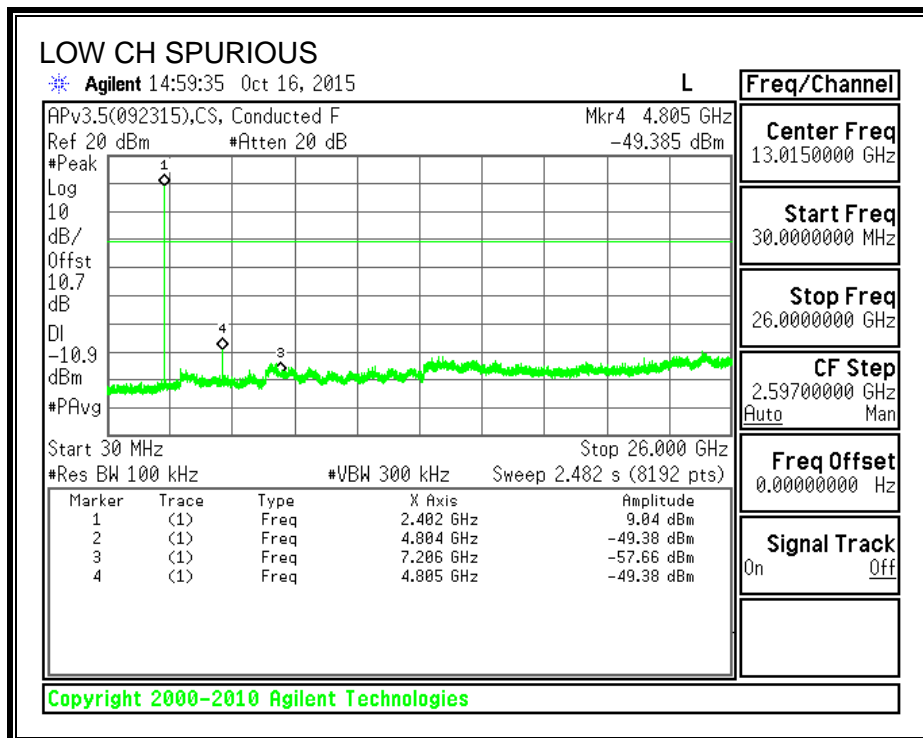
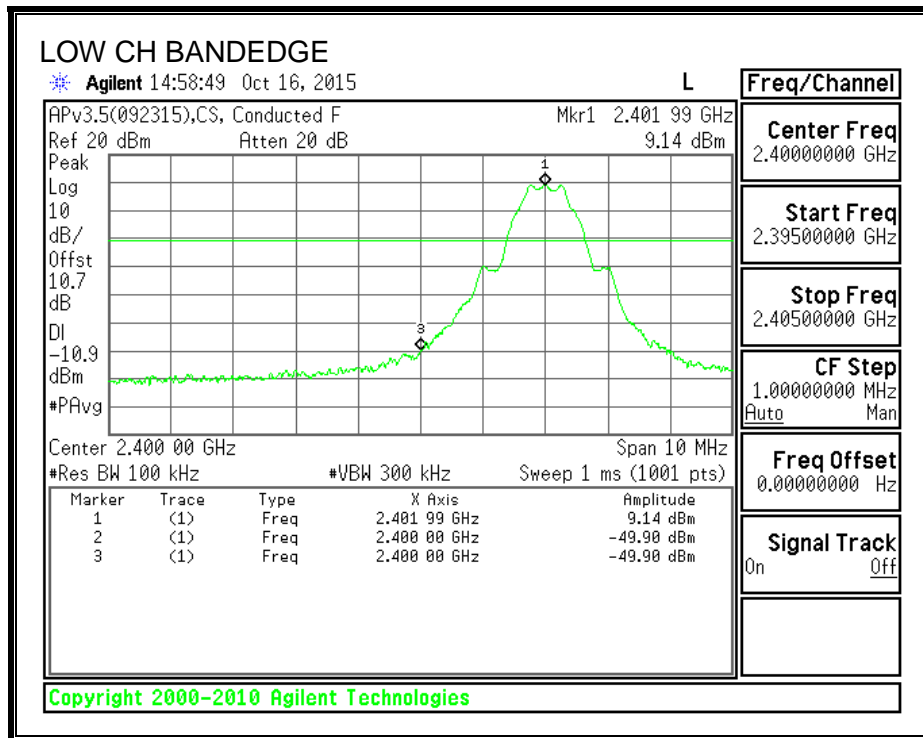

**SPURIOUS EMISSIONS, MID CHANNEL**

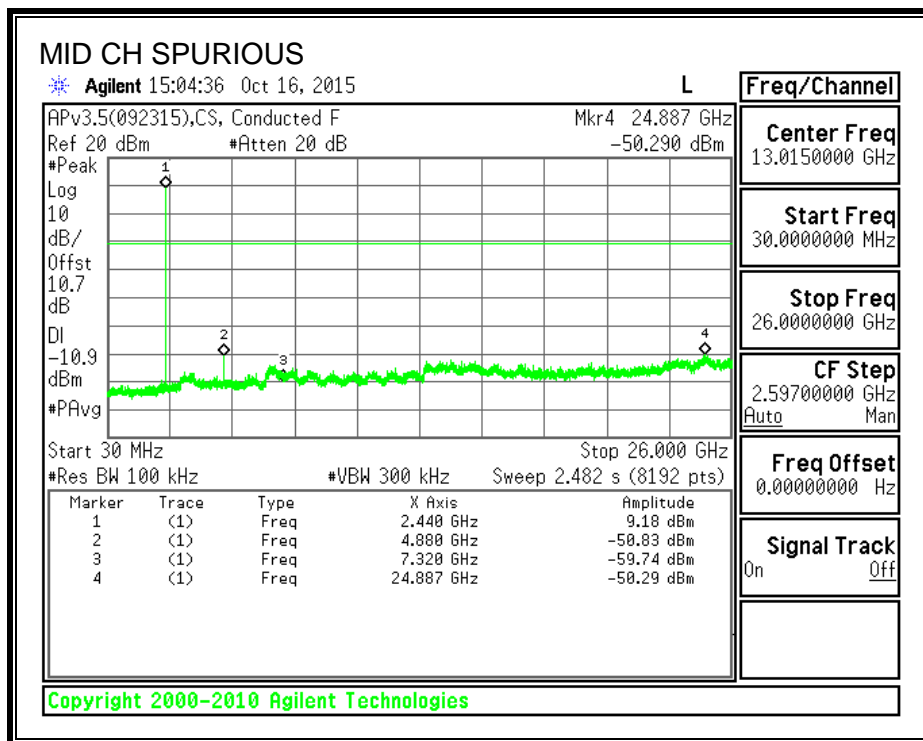
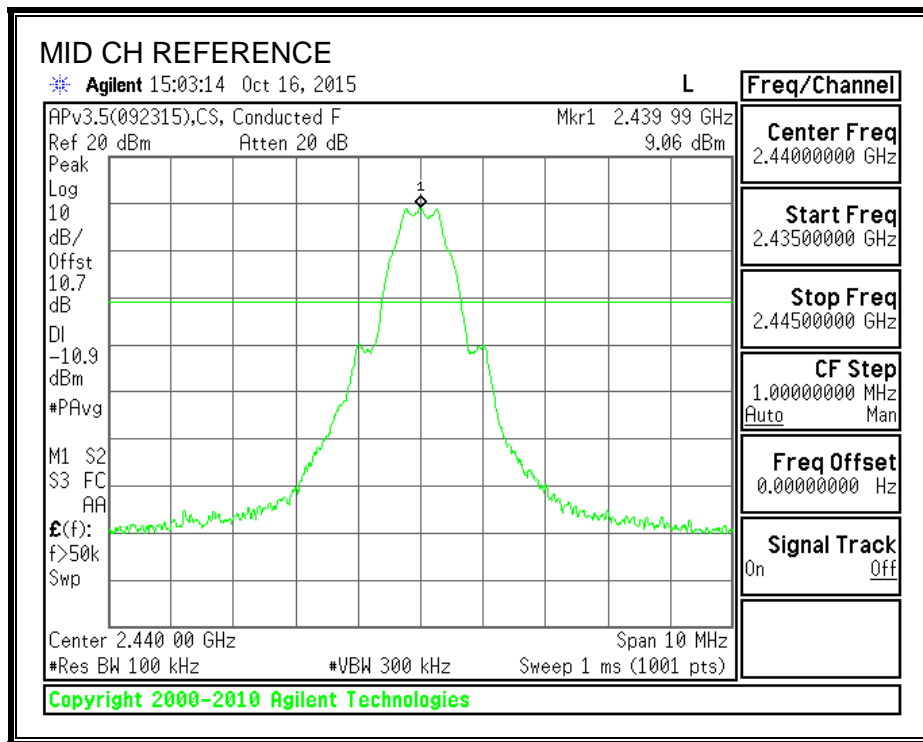



**SPURIOUS EMISSIONS, HIGH CHANNEL**

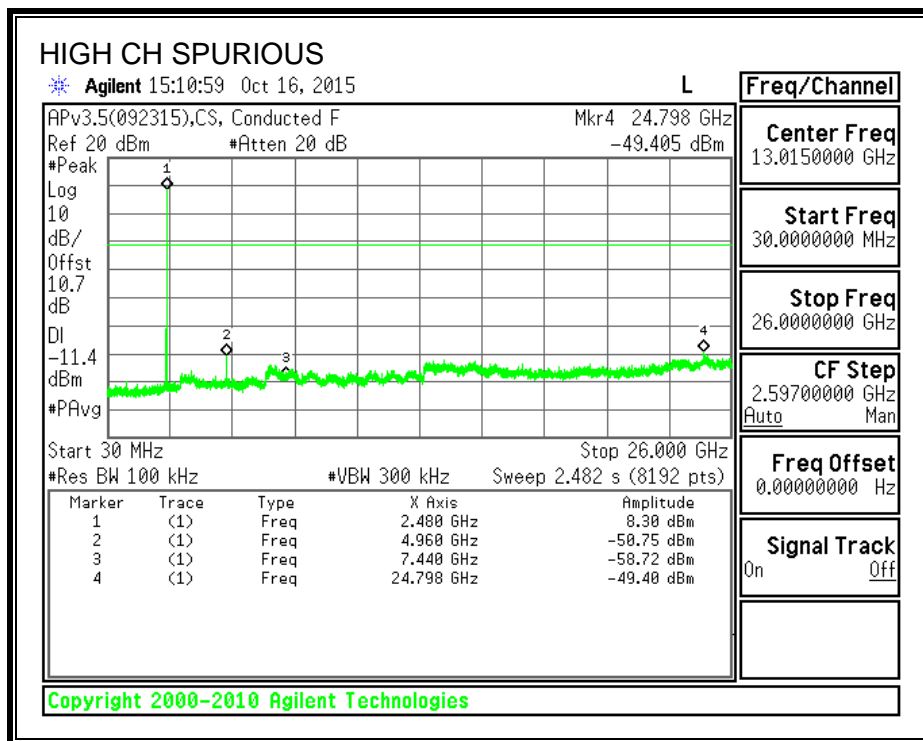
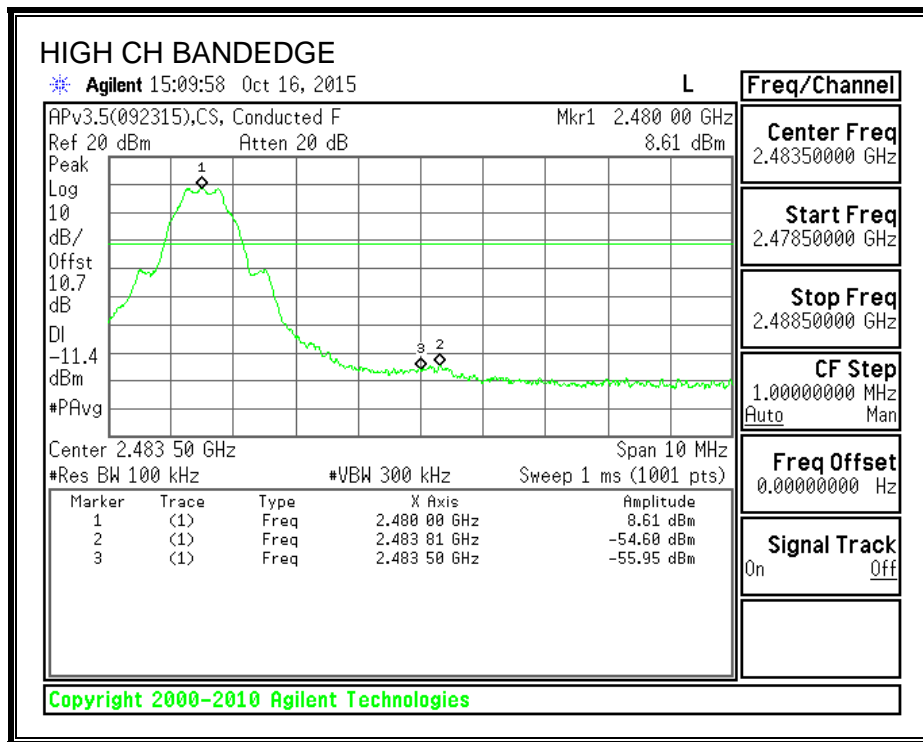

## 8. RADIATED TEST RESULTS

### 8.1. LIMITS AND PROCEDURE

#### LIMITS

FCC §15.205 and §15.209

IC RSS-GEN, Section 8.9 and 8.10

Frequency Range (MHz)	Field Strength Limit (uV/m) at 3 m	Field Strength Limit (dBuV/m) at 3 m
30 - 88	100	40
88 - 216	150	43.5
216 - 960	200	46
Above 960	500	54

#### TEST PROCEDURE

The EUT is placed on a non-conducting table 80 cm above the ground plane for measurement below 1GHz; 1.5 m above the ground plane for measurement above 1GHz. The antenna to EUT distance is 3 meters. The EUT is configured in accordance with ANSI C63.10. The EUT is set to transmit in a continuous mode..

For measurements below 1 GHz the resolution bandwidth is set to 100 kHz for peak detection measurements or 120 kHz for quasi-peak detection measurements. Peak detection is used unless otherwise noted as quasi-peak.

For measurements above 1 GHz the resolution bandwidth is set to 1 MHz, then the video bandwidth is set to 3 MHz for peak measurements and 1 MHz resolution bandwidth with 3MHz video bandwidth with average detector for average measurements.

The spectrum from 30 MHz to 26 GHz is investigated with the transmitter set to the lowest, middle, and highest channels in the 2.4 GHz band.

The frequency range of interest is monitored at a fixed antenna height and EUT azimuth. The EUT is rotated through 360 degrees to maximize emissions received. The antenna is scanned from 1 to 4 meters above the ground plane to further maximize the emission. Measurements are made with the antenna polarized in both the vertical and the horizontal positions

## 8.2. TRANSMITTER ABOVE 1 GHz

### RESTRICTED BANDEDGE (LOW CHANNEL)

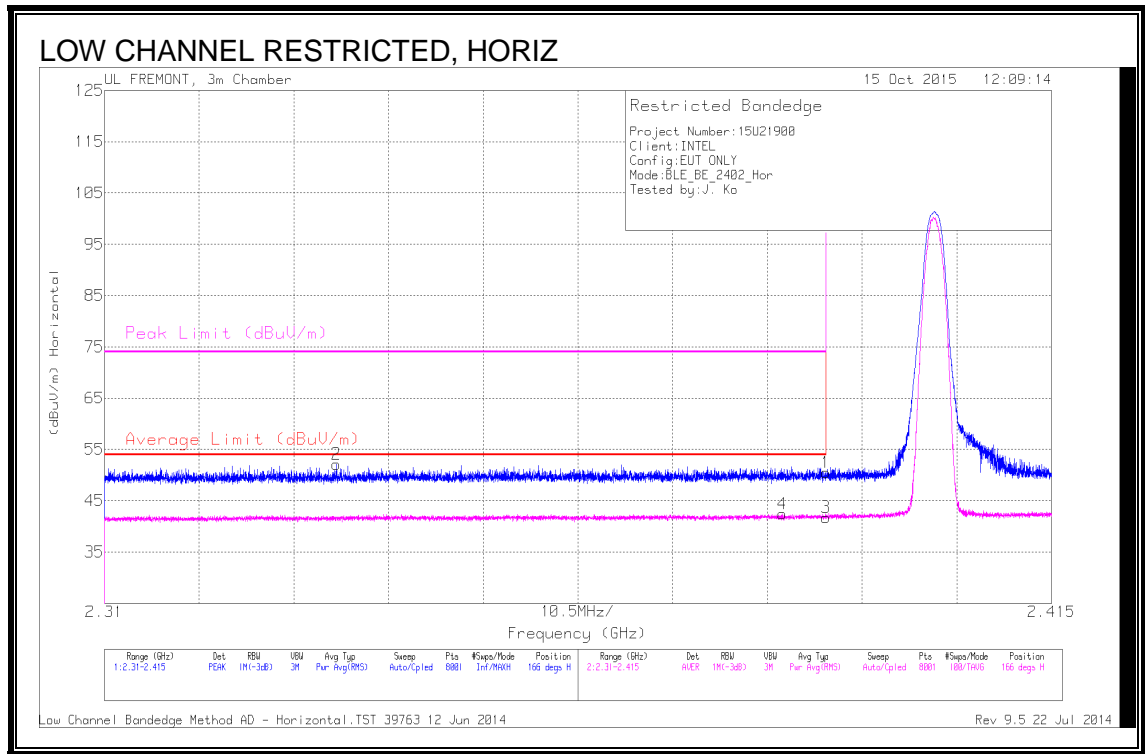

### Trace Markers

Marker	Frequency (GHz)	Meter Reading (dBuV)	Det	AF T119 (dB/m)	Amp/Cb/Filter/Pad (dB)	DC Corr (dB)	Corrected Reading (dBuV/m)	Average Limit (dBuV/m)	Margin (dB)	Peak Limit (dBuV/m)	PK Margin (dB)	Azimuth (Degs)	Height (cm)	Polarity
2	2.336	42.83	PK	31.8	-22.5	0	52.13	-	-	74	-21.87	166	191	H
4	2.385	30.79	RMS	32	-22.4	2.06	42.45	54	-11.55	-	-	166	191	H
1	2.39	40.88	PK	32	-22.4	0	50.48	-	-	74	-23.52	166	191	H
3	2.39	30.09	RMS	32	-22.4	2.06	41.75	54	-12.25	-	-	166	191	H

PK - Peak detector

RMS - RMS detection

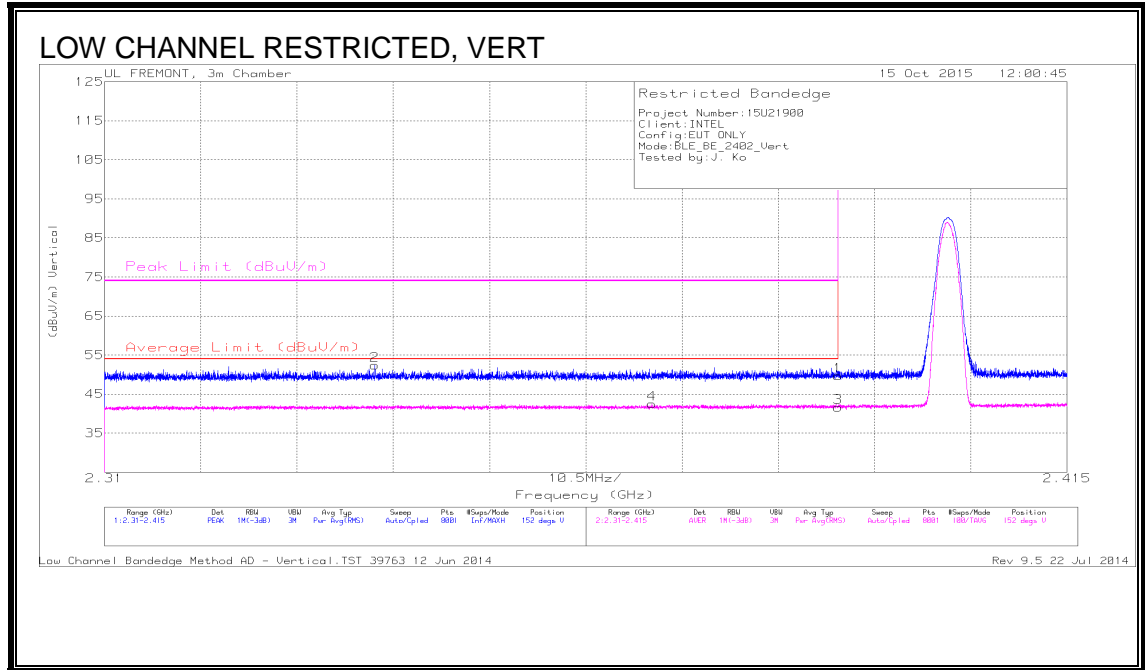

Trace Markers

Marker	Frequency (GHz)	Meter Reading (dBuV)	Det	AF T119 (dB/m)	Amp/Cb/Filter/Pad (dB)	DC Corr (dB)	Corrected Reading (dBuV/m)	Average Limit (dBuV/m)	Margin (dB)	Peak Limit (dBuV/m)	PK Margin (dB)	Azimuth (Degs)	Height (cm)	Polarity
2	2.339	43.02	PK	31.8	-22.4	0	52.42	-	-	74	-21.58	152	250	V
4	2.37	30.96	RMS	31.9	-22.4	2.06	42.52	54	-11.48	-	-	152	250	V
1	2.39	40.12	PK	32	-22.4	0	49.72	-	-	74	-24.28	152	250	V
3	2.39	29.91	RMS	32	-22.4	2.06	41.57	54	-12.43	-	-	152	250	V

PK - Peak detector

RMS - RMS detection

**AUTHORIZED BANDEDGE (HIGH CHANNEL)**

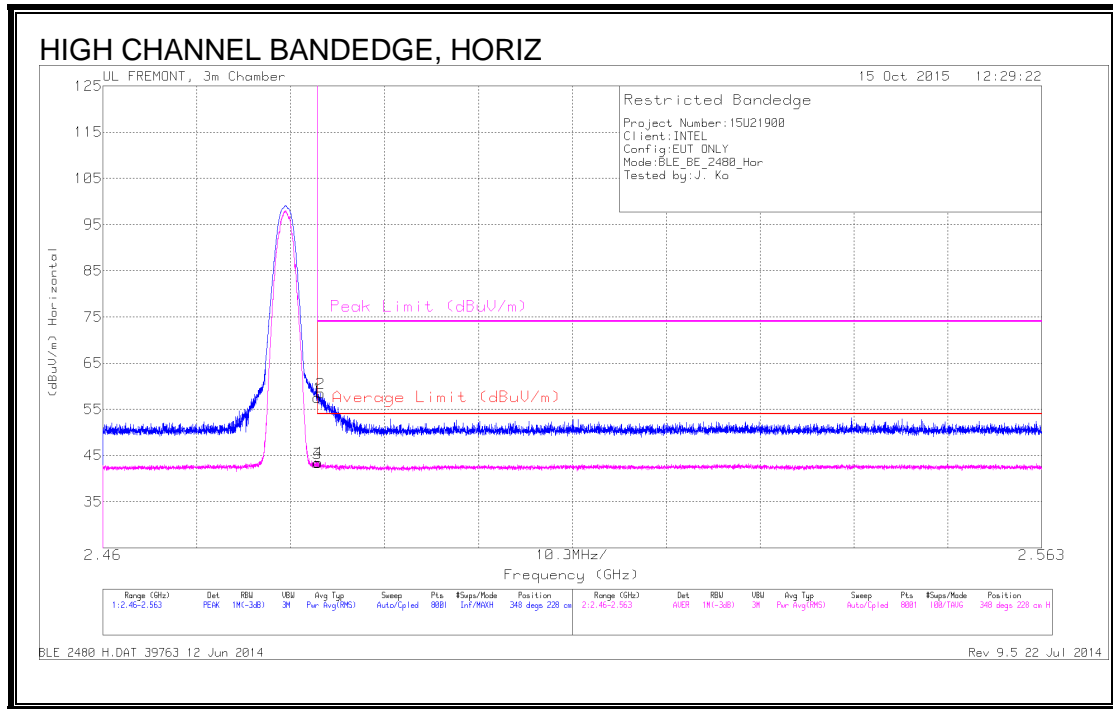

**Trace Markers**

Marker	Frequency (GHz)	Meter Reading (dBuV)	Det	AF T119 (dB/m)	Amp/Cb/Flt r/Pad (dB)	DC Corr (dB)	Corrected Reading (dBuV/m)	Average Limit (dBuV/m)	Margin (dB)	Peak Limit (dBuV/m)	PK Margin (dB)	Azimuth (Degs)	Height (cm)	Polarity
1	2.484	47.25	PK	32.3	-22.1	0	57.45	-	-	74	-16.55	348	228	H
2	2.484	48.32	PK	32.3	-22.1	0	58.52	-	-	74	-15.48	348	228	H
3	2.484	31.1	RMS	32.3	-22.1	2.06	43.36	54	-10.64	-	-	348	228	H
4	2.484	31.26	RMS	32.3	-22.1	2.06	43.52	54	-10.48	-	-	348	228	H

PK - Peak detector

RMS - RMS detection

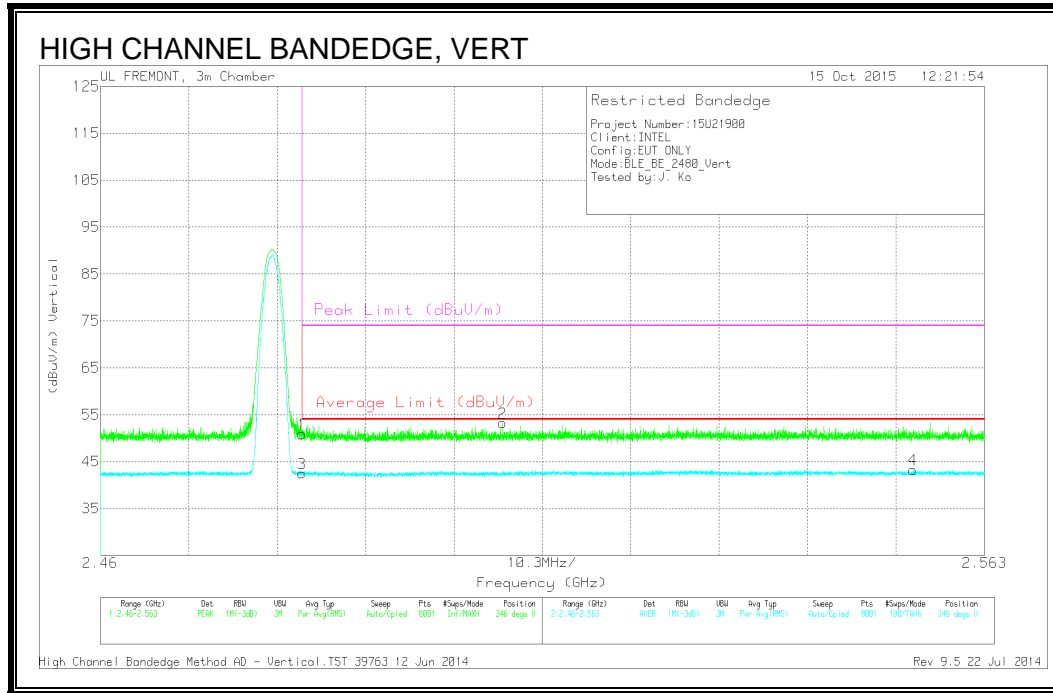

Trace Markers

Marker	Frequency (GHz)	Meter Reading (dBuV)	Det	AF T119 (dB/m)	Amp/Cb/Fitter/Pad (dB)	DC Corr (dB)	Corrected Reading (dBuV/m)	Average Limit (dBuV/m)	Margin (dB)	Peak Limit (dBuV/m)	PK Margin (dB)	Azimuth (Degs)	Height (cm)	Polarity
1	2.484	40.7	PK	32.3	-22.1	0	50.9	-	-	74	-23.1	346	151	V
3	2.484	30.23	RMS	32.3	-22.1	2.06	42.49	54	-11.51	-	-	346	151	V
2	2.507	43.06	PK	32.3	-22.1	0	53.26	-	-	74	-20.74	346	151	V
4	2.555	30.83	RMS	32.4	-22	2.06	43.29	54	-10.71	-	-	346	151	V

PK - Peak detector

RMS - RMS detection

**HARMONICS AND SPURIOUS EMISSIONS**

**LOW CHANNEL**

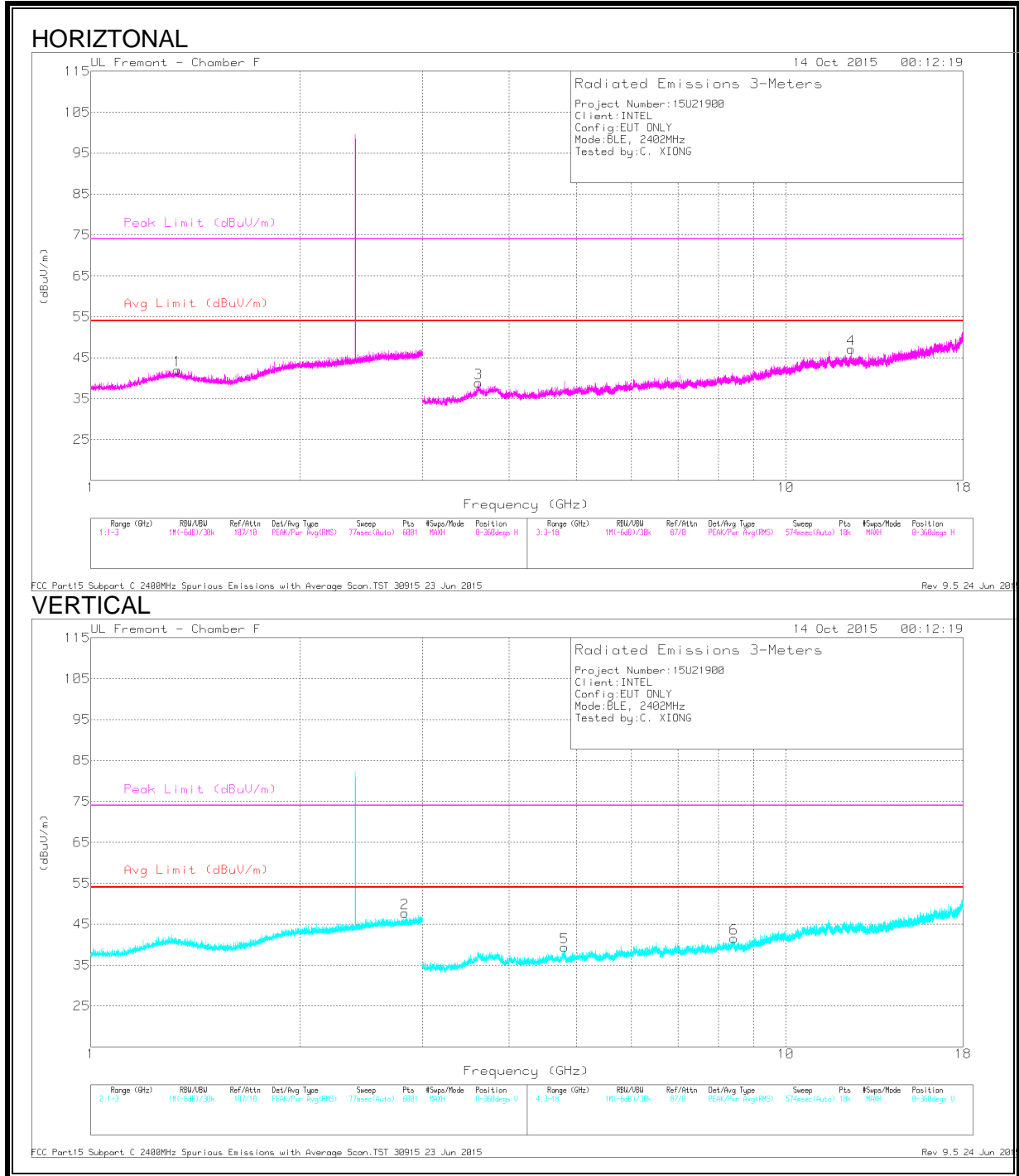

Note: Emission was scanned up to 26GHz; No emissions were detected above the noise floor which was at least 20dB below the specification limit.

DATA

Marker	Frequenc y (GHz)	Meter Reading (dBuV)	Det	AF T120 (dB/m)	Amp/Cbl/ Filtr/Pad (dB)	DC Corr (dB)	Corrected Reading (dBuV/m)	Avg Limit (dBuV/m)	Margin (dB)	Peak Limit (dBuV/m)	PK Margin (dB)	Azimuth (Degs)	Height (cm)	Polarity
1	* 1.332	34.48	PK2	29.7	-22.2	0	41.98			74	-32.02	154	163	H
	* 1.332	24.91	MAv1	29.7	-22.2	2.06	34.47	54	-19.53	-	-	154	163	H
2	* 2.829	42.1	PK2	32.7	-20.4	0	54.4	-	-	74	-19.6	172	156	V
	* 2.832	30.3	MAv1	32.7	-20.5	2.06	44.56	54	-9.44	-	-	172	156	V
3	* 3.616	41.98	PK2	35	-29.2	0	47.78	-	-	74	-26.22	142	188	H
	* 3.616	29.87	MAv1	35	-29.2	2.06	37.73	54	-16.27	-	-	142	188	H
4	* 12.425	36.08	PK2	39.1	-22.5	0	52.68	-	-	74	-21.32	173	212	H
	* 12.424	25.33	MAv1	39.1	-22.5	2.06	43.99	54	-10.01	-	-	173	212	H
5	* 4.805	42	PK2	34.1	-27.7	0	48.4	-	-	74	-25.6	165	203	V
	* 4.804	30.03	MAv1	34.1	-27.7	2.06	38.49	54	-15.51	-	-	165	203	V
6	* 8.422	37.79	PK2	35.8	-24.2	0	49.39	-	-	74	-24.61	155	185	V
	* 8.421	26.32	MAv1	35.8	-24.2	2.06	39.98	54	-14.02	-	-	155	185	V

\* - indicates frequency in CFR15.205/IC7.2.2 Restricted Band

PK2 - KDB558074 Method: Maximum Peak

MAv1 - KDB558074 Option 1 Maximum RMS Average



**MID CHANNEL**

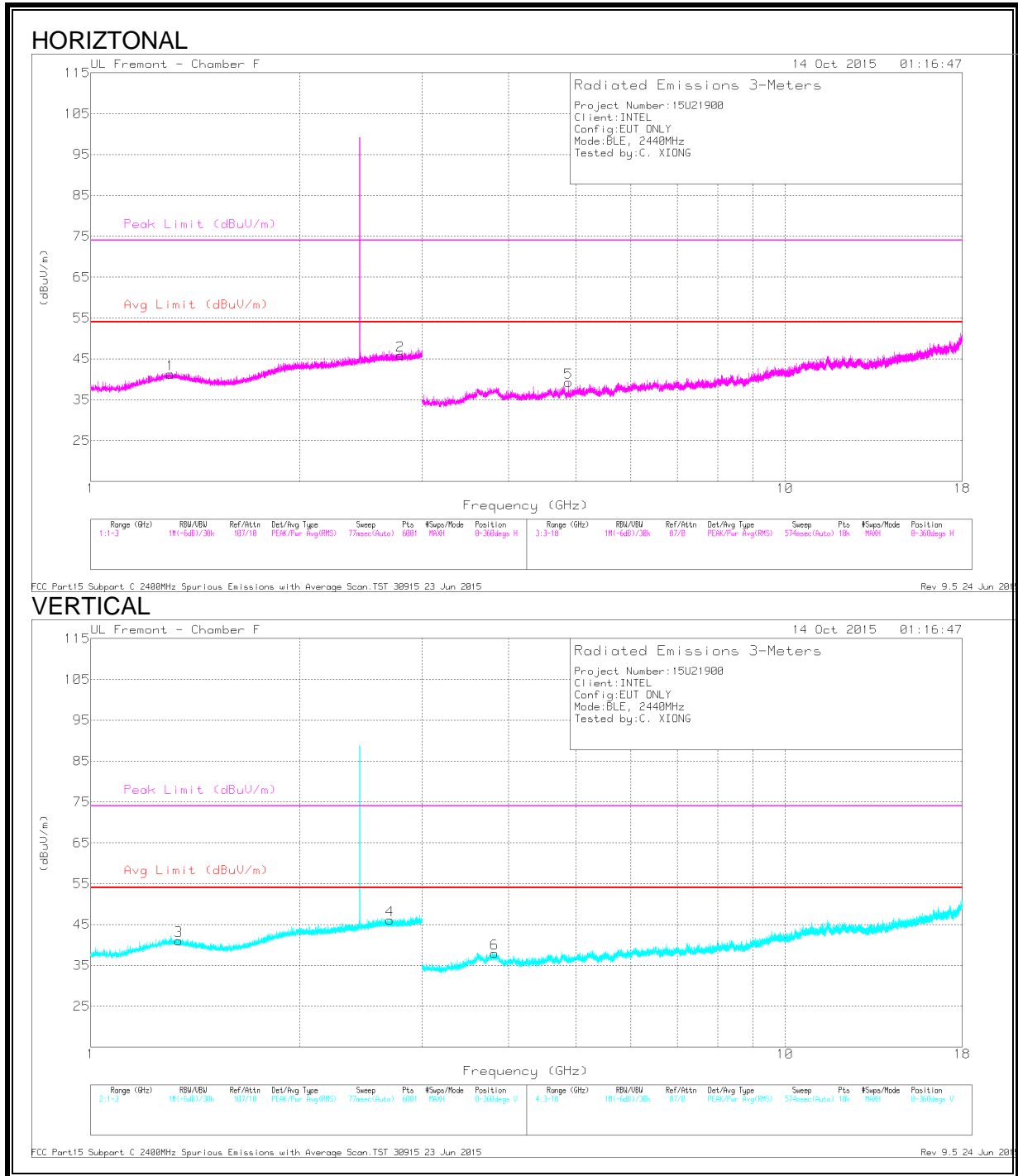

Note: Emission was scanned up to 26GHz; No emissions were detected above the noise floor which was at least 20dB below the specification limit.

DATA

Marker	Frequenc y (GHz)	Meter Reading (dBuV)	Det	AF T120 (dB/m)	Amp/Cbl /Filtr/Pad (dB)	DC Corr (dB)	Corrected Reading (dBuV/m)	Avg Limit (dBuV/m)	Margin (dB)	Peak Limit (dBuV/m)	PK Margin (dB)	Azimuth (Degs)	Height (cm)	Polarity
1	* 1.304	41.79	PK2	30	-22.2	0	49.59	-	-	74	-24.41	0	101	H
	* 1.302	30.42	MAv1	30	-22.2	2.06	40.28	54	-13.72	-	-	0	101	H
2	* 2.794	42.01	PK2	32.7	-20.6	0	54.11	-	-	74	-19.89	0	101	H
	* 2.794	30.25	MAv1	32.7	-20.6	2.06	44.41	54	-9.59	-	-	0	101	H
3	* 1.339	42.44	PK2	29.7	-22.2	0	49.94	-	-	74	-24.06	0	101	V
	* 1.339	30.5	MAv1	29.7	-22.2	2.06	40.06	54	-13.94	-	-	0	101	V
4	* 2.699	42.64	PK2	32.7	-20.8	0	54.54	-	-	74	-19.46	0	101	V
	* 2.699	30.44	MAv1	32.7	-20.8	2.06	44.40	54	-9.60	-	-	0	101	V
5	* 4.88	38.9	PK2	34.1	-27.9	0	45.1	-	-	74	-28.9	0	101	H
	* 4.88	27.28	MAv1	34.1	-27.9	2.06	35.54	54	-18.46	-	-	0	101	H
6	* 3.813	41.32	PK2	34.1	-28.7	0	46.72	-	-	74	-27.28	0	101	V
	* 3.815	29.86	MAv1	34.1	-28.6	2.06	37.42	54	-16.58	-	-	0	101	V

\* - indicates frequency in CFR15.205/IC7.2.2 Restricted Band

PK2 - KDB558074 Method: Maximum Peak

MAv1 - KDB558074 Option 1 Maximum RMS Average

**HIGH CHANNEL**

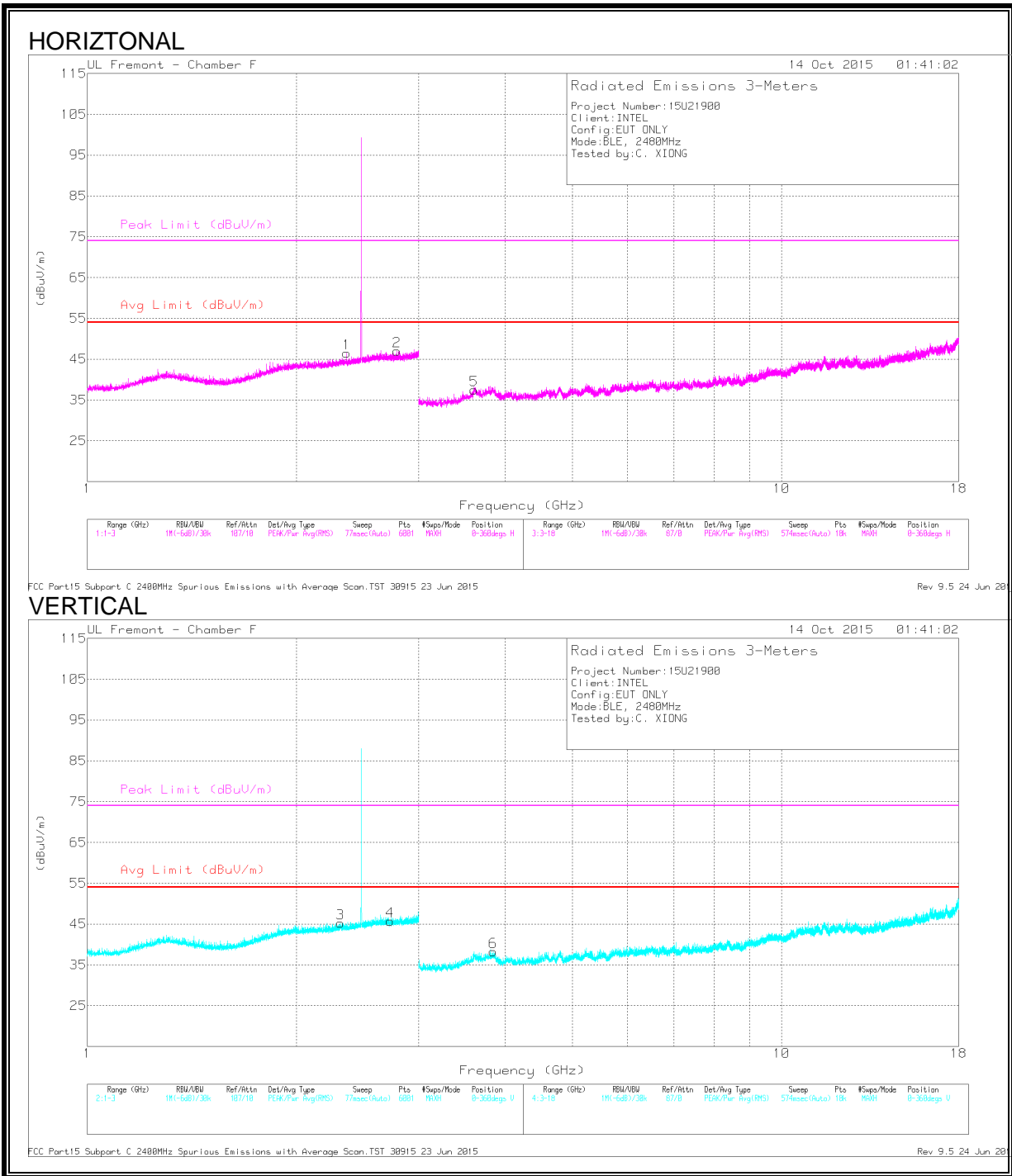

Note: Emission was scanned up to 26GHz; No emissions were detected above the noise floor which was at least 20dB below the specification limit.

DATA

Marker	Frequenc y (GHz)	Meter Reading (dBuV)	Det	AF T120 (dB/m)	Amp/Cbl/ Fitr/Pad (dB)	DC Corr (dB)	Corrected Reading (dBuV/m)	Avg Limit (dBuV/m)	Margin (dB)	Peak Limit (dBuV/m)	PK Margin (dB)	Azimuth (Degs)	Height (cm)	Polarity
1	* 2.362	42.01	PK2	31.9	-21.1	0	52.81	-	-	74	-21.19	0	100	H
	* 2.363	30.45	MAv1	31.9	-21	2.06	43.41	54	-10.59	-	-	0	100	H
2	* 2.792	41.7	PK2	32.7	-20.6	0	53.8	-	-	74	-20.2	0	202	H
	* 2.793	30.32	MAv1	32.7	-20.6	2.06	44.48	54	-9.52	-	-	0	202	H
3	* 2.317	42.39	PK2	31.8	-21.1	0	53.09	-	-	74	-20.91	0	101	V
	* 2.315	30.35	MAv1	31.8	-21.1	2.06	43.11	54	-10.89	-	-	0	101	V
4	* 2.73	41.66	PK2	32.7	-20.8	0	53.56	-	-	74	-20.44	0	124	V
	* 2.73	30.25	MAv1	32.7	-20.8	2.06	44.21	54	-9.79	-	-	0	124	V
5	* 3.605	41.2	PK2	35	-29.2	0	47	-	-	74	-27	0	203	H
	* 3.607	30.14	MAv1	35	-29.2	2.06	38.00	54	-16.00	-	-	0	203	H
6	* 3.843	41.43	PK2	34	-28.3	0	47.13	-	-	74	-26.87	0	101	V
	* 3.843	29.64	MAv1	34	-28.3	2.06	37.40	54	-16.60	-	-	0	101	V

\* - indicates frequency in CFR15.205/IC7.2.2 Restricted Band

PK2 - KDB558074 Method: Maximum Peak

MAv1 - KDB558074 Option 1 Maximum RMS Average

### 8.3. WORST-CASE BELOW 1 GHz

#### SPURIOUS EMISSIONS 30 TO 1000 MHz (WORST-CASE CONFIGURATION)

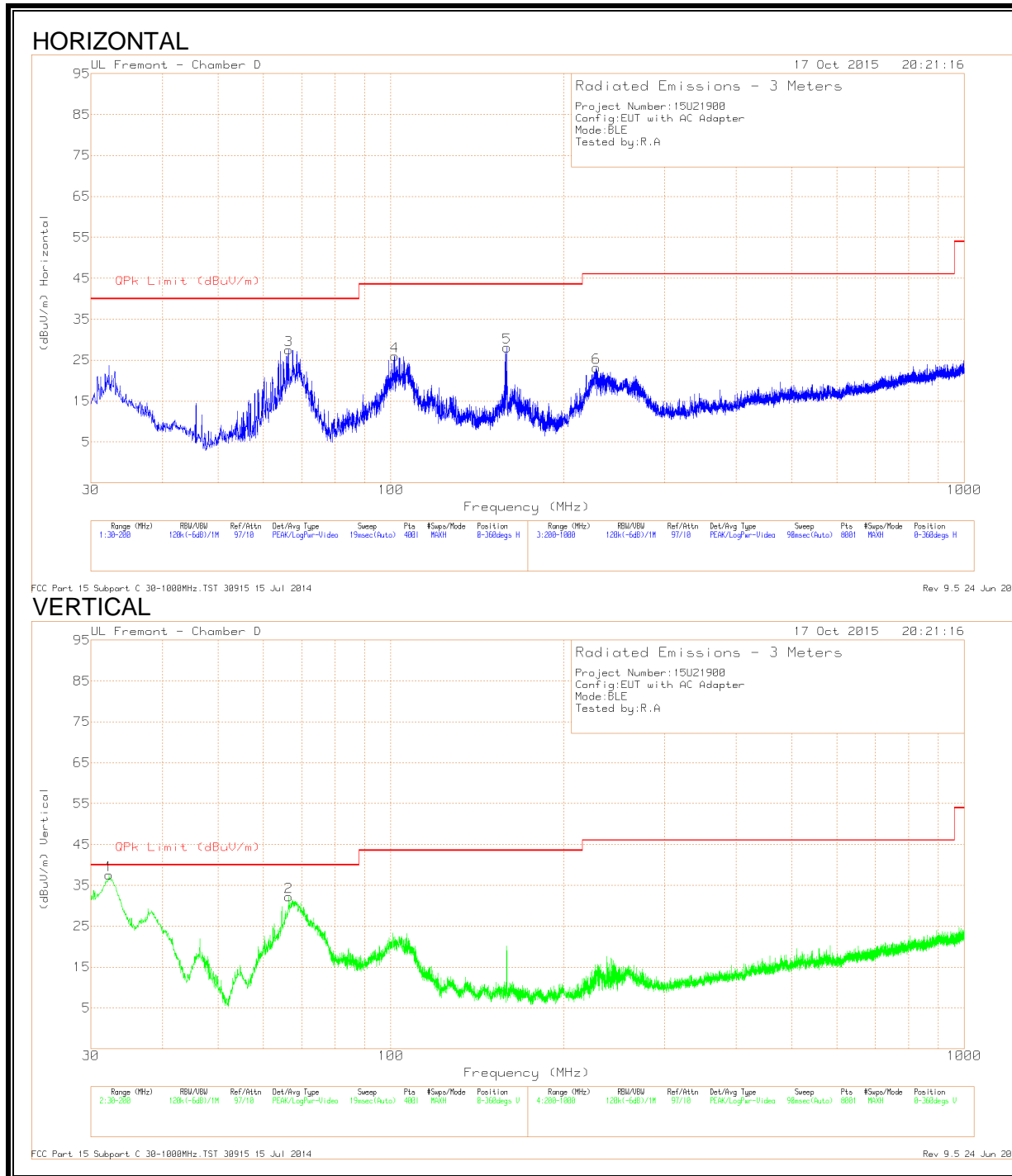

**DATA**

Marker	Frequency (MHz)	Meter Reading (dBuV)	Det	AF T407 (dB/m)	Amp/Cbl (dB)	Corrected Reading (dBuV/m)	QPk Limit (dBuV/m)	Margin (dB)	Azimuth (Degs)	Height (cm)	Polarity
1	32.295	49.29	Pk	20.1	-31.9	37.49	40	-2.51	0-360	100	V
3	66.38	51.06	Pk	8	-31.5	27.56	40	-12.44	0-360	401	H
2	66.465	55.65	Pk	8	-31.5	32.15	40	-7.85	0-360	100	V
4	101.5275	46.84	Pk	10.5	-31.4	25.94	43.52	-17.58	0-360	301	H
5	159.4125	46.98	Pk	12.1	-31	28.08	43.52	-15.44	0-360	401	H
6	228.3	42.93	Pk	10.9	-30.7	23.13	46.02	-22.89	0-360	100	H

Pk - Peak detector

**Radiated Emissions**

Frequency (MHz)	Meter Reading (dBuV)	Det	AF T407 (dB/m)	Amp/Cbl (dB)	Corrected Reading (dBuV/m)	QPk Limit (dBuV/m)	Margin (dB)	Azimuth (Degs)	Height (cm)	Polarity
32.4781	37.34	Qp	19.9	-31.8	25.44	40	-14.56	276	105	V

Qp - Quasi-Peak detector

## 9. AC POWER LINE CONDUCTED EMISSIONS

### LIMITS

FCC §15.207 (a)

RSS-Gen 8.8

Frequency of Emission (MHz)	Conducted Limit (dB $\mu$ V)	
	Quasi-peak	Average
0.15-0.5	66 to 56 *	56 to 46 *
0.5-5	56	46
5-30	60	50

### TEST PROCEDURE

C63.10

### RESULTS

### 9.1. EUT WITH AC ADAPTER

#### LINE 1 RESULTS

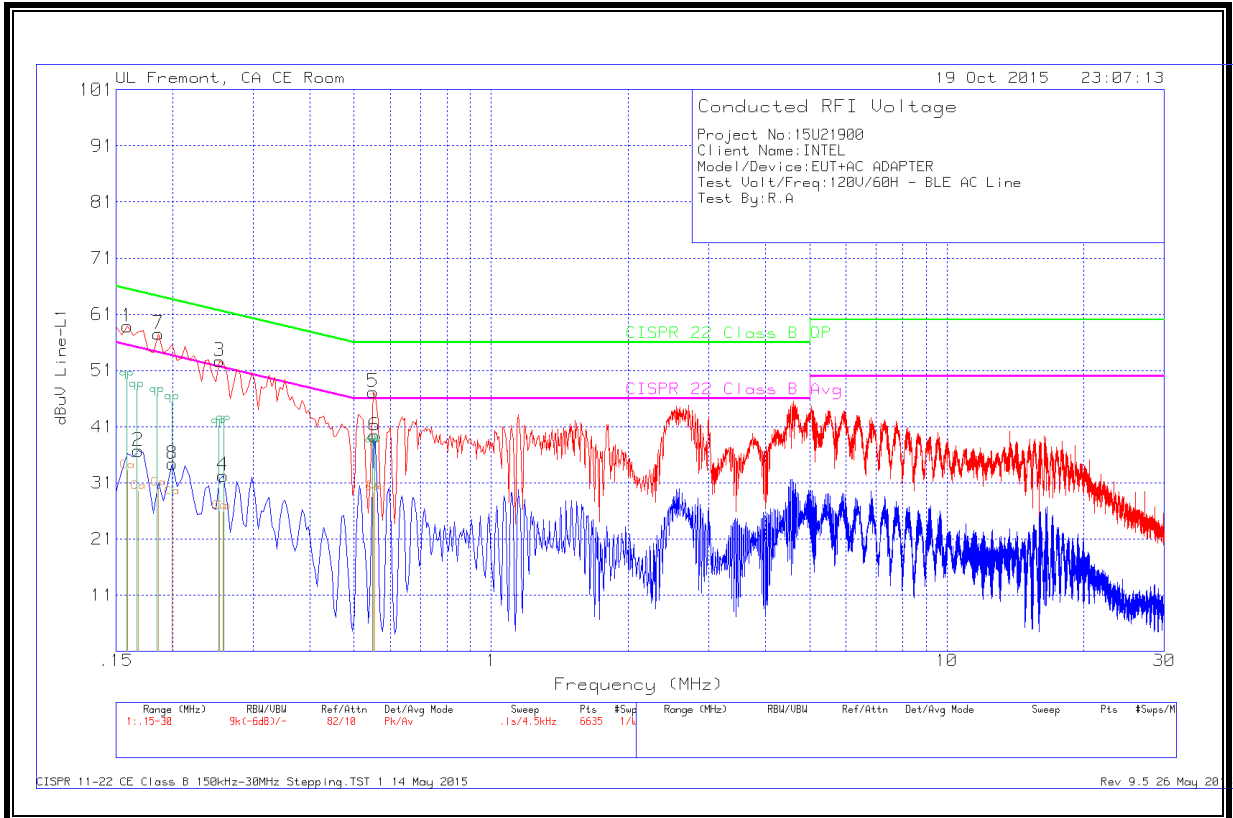



**DATA**

Range 1: Line-L1 .15 - 30MHz

Frequency (MHz)	Meter Reading (dBuV)	Det	T24 IL L1	LC Cables 1&3	Corrected Reading dBuV	CISPR 22 Class B QP	Margin (dB)	CISPR 22 Class B Avg	Margin (dB)
.15878	48.23	Qp	1.3	0	49.53	65.53	-16	-	-
.16688	46.37	Qp	1.2	0	47.57	65.11	-17.54	-	-
.25238	40.38	Qp	.7	0	41.08	61.68	-20.6	-	-
.25868	40.9	Qp	.7	0	41.6	61.47	-19.87	-	-
.54938	37.32	Qp	.3	0	37.62	56	-18.38	-	-
.55388	37.76	Qp	.3	0	38.06	56	-17.94	-	-
.18488	45.62	Qp	1	0	46.62	64.26	-17.64	-	-
.19928	44.46	Qp	.9	0	45.36	63.64	-18.28	-	-

Qp - Quasi-Peak detector

Range 1: Line-L1 .15 - 30MHz

Frequency (MHz)	Meter Reading (dBuV)	Det	T24 IL L1	LC Cables 1&3	Corrected Reading dBuV	CISPR 22 Class B QP	Margin (dB)	CISPR 22 Class B Avg	Margin (dB)
.15878	31.81	Ca	1.3	0	33.11	-	-	55.53	-22.42
.16688	28.22	Ca	1.2	0	29.42	-	-	55.11	-25.69
.25238	25.2	Ca	.7	0	25.9	-	-	51.68	-25.78
.25868	25.09	Ca	.7	0	25.79	-	-	51.47	-25.68
.54938	28.9	Ca	.3	0	29.2	-	-	46	-16.8
.55388	29.29	Ca	.3	0	29.59	-	-	46	-16.41
.18488	29.03	Ca	1	0	30.03	-	-	54.26	-24.23
.19928	27.53	Ca	.9	0	28.43	-	-	53.64	-25.21

Ca - CISPR average detection

**LINE 2 RESULTS**

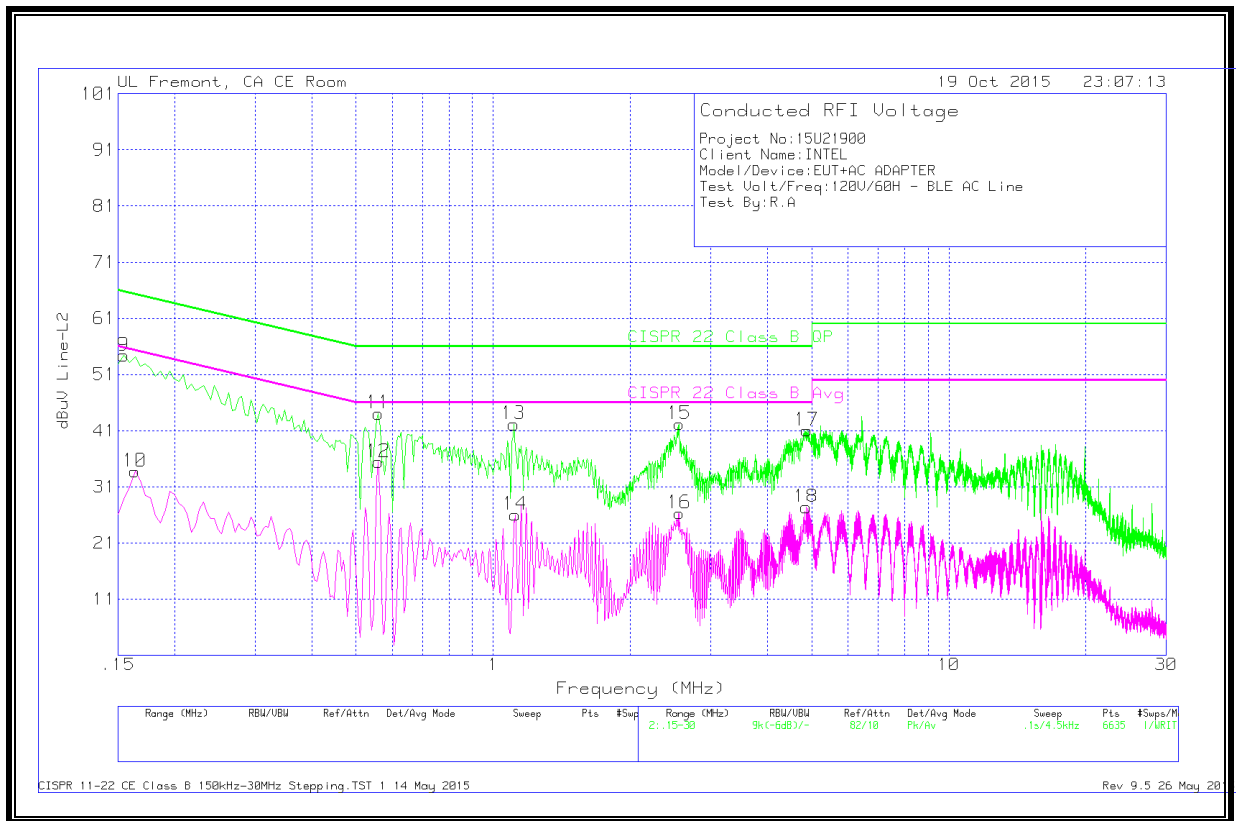

**DATA**

Range 2: Line-L2 .15 - 30MHz

Marker	Frequency (MHz)	Meter Reading (dBuV)	Det	T24 IL L2	LC Cables 2&3	Corrected Reading dBuV	CISPR 22 Class B QP	Margin (dB)	CISPR 22 Class B Avg	Margin (dB)
9	.1545	52.98	Pk	1.4	0	54.38	65.75	-11.37		
10	.1635	32.44	Av	1.3	0	33.74	-	-	55.28	-21.54
11	.5595	43.78	Pk	.3	0	44.08	56	-11.92		
12	.5595	35.11	Av	.3	0	35.41	-	-	46	-10.59
13	1.1085	41.85	Pk	.3	0	42.15	56	-13.85		
14	1.1175	25.73	Av	.3	0	26.03	-	-	46	-19.97
15	2.562	41.88	Pk	.2	.1	42.18	56	-13.82		
16	2.562	26	Av	.2	.1	26.3	-	-	46	-19.7
17	4.884	40.74	Pk	.2	.1	41.04	56	-14.96		
18	4.8615	27.08	Av	.2	.1	27.38	-	-	46	-18.62

Pk - Peak detector

Av - Average detection

## 9.2. EUT WITH USB LAPTOP

### LINE 1 RESULTS

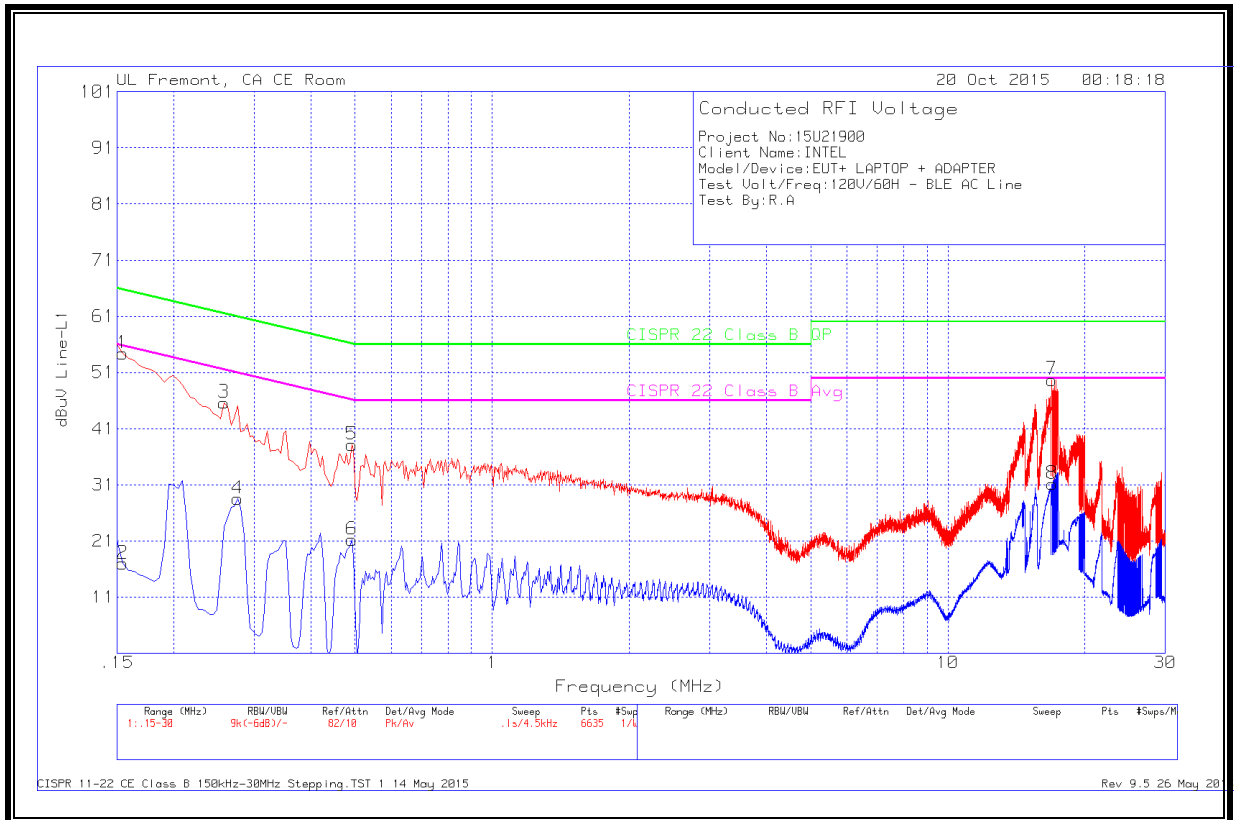

### DATA

Range 1: Line-L1 .15 - 30MHz

Marker	Frequency (MHz)	Meter Reading (dBuV)	Det	T24 IL L1	LC Cables 1&3	Corrected Reading dBuV	CISPR 22 Class B QP	Margin (dB)	CISPR 22 Class B Avg	Margin (dB)
1	.1545	53.11	Pk	1.3	0	54.41	65.75	-11.34		
2	.1545	15.67	Av	1.3	0	16.97	-	-	55.75	-38.78
3	.258	44.92	Pk	.7	0	45.62	61.5	-15.88		
4	.276	27.92	Av	.6	0	28.52	-	-	50.94	-22.42
5	.492	37.83	Pk	.3	0	38.13	56.13	-18		
6	.492	20.94	Av	.3	0	21.24	-	-	46.13	-24.89
7	16.926	49.21	Pk	.3	.2	49.71	60	-10.29		
8	16.9485	30.67	Av	.3	.2	31.17	-	-	50	-18.83

Pk - Peak detector

Av - Average detection

**LINE 2 RESULTS**

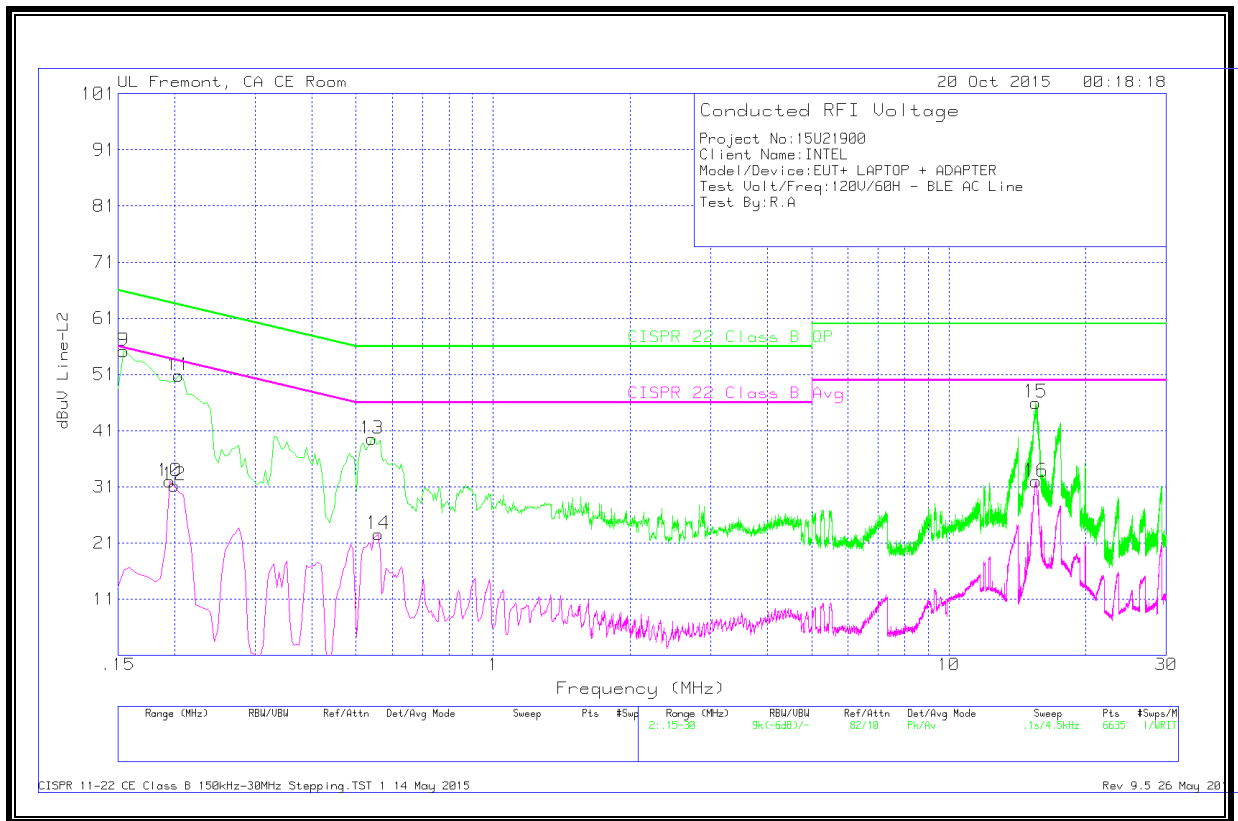

**DATA**

Range 2: Line-L2 .15 - 30MHz

Marker	Frequency (MHz)	Meter Reading (dBuV)	Det	T24 IL L2	LC Cables 2&3	Corrected Reading dBuV	CISPR 22 Class B QP	Margin (dB)	CISPR 22 Class B Avg	Margin (dB)
9	.1545	53.81	Pk	1.4	0	55.21	65.75	-10.54		
10	.195	30.99	Av	1	0	31.99	-	-	53.82	-21.83
11	.204	49.83	Pk	1	0	50.83	63.45	-12.62		
12	.1995	30.27	Av	1	0	31.27	-	-	53.63	-22.36
13	.5415	39.26	Pk	.3	0	39.56	56	-16.44		
14	.5595	22.27	Av	.3	0	22.57	-	-	46	-23.43
15	15.513	45.5	Pk	.3	.2	46	60	-14		
16	15.5355	31.47	Av	.3	.2	31.97	-	-	50	-18.03

Pk - Peak detector

Av - Average detection