



# FCC & ISED Canada

## ***TECHNICAL COMPLIANCE STATEMENT***

For the

**Product** : Multi Function Peripheral  
(copier, printer, scanner, facsimile (optional))

**FCC ID** : 2AB83-D332A

**Model** : D332A

**Multiple Model** : D331A, D330A

**Applicant** : Sindoh Co., Ltd.

**FCC Rule** : CFR 47 Part 15 Subpart B §15.101

**ISED Canada Rule** : ICES-003

We hereby certify that the above product has been tested by us with the listed rules and found in compliance with the regulation. The test data and results are issued on the test report no. **TR-W2007-010**

Signature

  
Choi, Young-min / Technical Manager

Date: 2020-07-10

**Test Laboratory: ENG Co., Ltd.**

*It shall not be reproduced except in full, without the written approval of the ENG Co., Ltd. This document may be altered or revised by the ENG Co., Ltd. personnel only, and shall be noted in the revision section of the document. The test results in the report only apply to the tested sample.*

---

Report No.: TR-W2007-010

ENG Co., Ltd. 135-60 Gyeongchung-daero, Gonjam-eup, Gwangju-si, Gyeonggi-do, Korea 12813

Report Form\_18 (Rev.0)

# FCC & ISED Canada TEST REPORT

**Project Number** : EA2005C-031  
**Test Report Number** : TR-W2007-010  
**Type of Equipment** : Multi Function Peripheral  
(copier, printer, scanner, facsimile (optional))  
**FCC ID** : 2AB83-D332A  
**Model Name** : D332A  
**Multiple Model Name** : D331A, D330A  
**Applicant** : Sindoh Co., Ltd.  
**Address** : 3, Seongsu-ro24 (isipsa)-gil, Seongdong-gu, Seoul 04797,  
Republic of Korea  
**Manufacturer** : Sindoh Co., Ltd.  
**Address** : 3, Seongsu-ro24 (isipsa)-gil, Seongdong-gu, Seoul 04797,  
Republic of Korea  
**FCC Rule** : FCC CFR 47 Part 15 Subpart B §15.101 Class A Device  
**ISED Canada Rule** : ICES-003 Issue 6 Class A Device  
**Total page of Report** : 123 pages  
**Date of Receipt** : 2020-05-19  
**Date of Issue** : 2020-07-10  
**Test Result** : Pass

This test report only contains the result of a single test of the sample supplied for the examination.  
It is not a generally valid assessment of the features of the respective products of the mass-production.

Prepared by Chu, Woo-sik / Senior Engineer

  
Signature

2020-07-10  
Date

Reviewed by Choi, Young-min / Technical Manager

  
Signature

2020-07-10  
Date

# CONTENTS

Page

<b>1. TEST SUMMARY .....</b>	<b>4</b>
<b>1.1 TEST STANDARDS AND RESULTS .....</b>	<b>4</b>
<b>1.2. TEST METHODOLOGY .....</b>	<b>4</b>
<b>1.3 ADDITIONS, DEVIATIONS, EXCLUSIONS FROM STANDARDS .....</b>	<b>4</b>
<b>1.4 PURPOSE OF THE TEST .....</b>	<b>4</b>
<b>1.5 TEST FACILITY .....</b>	<b>5</b>
<b>2. EUT (EQUIPMENT UNDER TEST) DESCRIPTION .....</b>	<b>6</b>
<b>2.1 GENERAL PRODUCT INFORMATION .....</b>	<b>7</b>
<b>2.2 ADDITIONAL MODEL .....</b>	<b>11</b>
<b>3. TEST CONDITION .....</b>	<b>12</b>
<b>3.1 EQUIPMENT USED DURING TEST .....</b>	<b>12</b>
<b>3.2 CABLE DESCRIPTION .....</b>	<b>12</b>
<b>3.3 OPERATING MODE OF THE EUT .....</b>	<b>13</b>
<b>3.4 MODE OF OPERATION DURING THE TEST .....</b>	<b>15</b>
<b>3.5 TEST SETUP DRAWING .....</b>	<b>16</b>
<b>4. EUT MODIFICATIONS .....</b>	<b>17</b>
<b>5. EMISSION TESTS .....</b>	<b>18</b>
<b>5.1 AC POWER LINE CONDUCTED EMISSION .....</b>	<b>18</b>
<b>5.2 RADIATED EMISSION .....</b>	<b>45</b>
<b>APPENDIX I - TEST INSTRUMENTATION .....</b>	<b>82</b>
<b>APPENDIX II - TEST SETUP PHOTOS: AC POWER LINE CONDUCTED EMISSION TEST .....</b>	<b>83</b>
<b>APPENDIX III - TEST SETUP PHOTOS: RADIATED EMISSION TEST .....</b>	<b>86</b>
<b>APPENDIX IV - IDENTIFICATION LABEL .....</b>	<b>92</b>
<b>APPENDIX V - PHOTOGRAPHS REPORT (EXTERNAL PHOTOS) .....</b>	<b>93</b>
<b>APPENDIX VI - PHOTOGRAPHS REPORT (INTERNAL PHOTOS) .....</b>	<b>104</b>

### Release Control Record

Issue Report No.	Issued Date	Details/Revisions
TR-W2007-010	2020-07-10	Initial Release

## 1. TEST SUMMARY

### 1.1 Test standards and results

The sample submitted for evaluation (Hereafter refer to as the EUT) has been tested in accordance with the following specifications:

Agency	APPLICABLE SECTION	TEST DESCRIPTION	RESULTS
FCC	Part 15 Subpart B Section 15.107 (b)	AC Power Line Conducted Emission	PASS
	Part 15 Subpart B Section 15.109 (b)	Radiated Emission	PASS
ISED	ICES-003 Section 6.1 Table 2	AC Power Line Conducted Emission	PASS
	ICES-003 Section 6.2.1 Table 5	Radiated Emission	PASS

### 1.2. Test Methodology

FCC: ANSI C 63.4: 2014, FCC CFR 47 Part 2 and Part 15, and ICES-003.

### 1.3 Additions, deviations, exclusions from standards







No additions, deviations or exclusions have been made from standard.

### 1.4 Purpose of the test

To determine whether the equipment under test fulfills the FCC and ISED Canada Rules, Regulation and standards stated in section 1.1 and 1.2.

## 1.5 Test Facility

The measurement facilities are located at 135-60 Gyeongchung-daero, Gonjiam-eup, Gwangju-si, Gyeonggi-do 12813, Korea. Our test facilities are accredited as a Conformity Assessment Body (CAB) by the FCC and ISED Canada, designated by the RRA (National Radio Research Agency), and accredited by KOLAS (Korea Laboratory Accreditation Scheme) in Korea and approved by TUV Rheinland, TUV SÜD and Korean Register of Shipping according to the requirement of ISO/IEC 17025.

Laboratory Qualification	Registration No.	Mark
FCC	KR0160	
ISED Canada	12721A	
RRA	KR0160	
TUV Rheinland	UA 50314109-0002	
TUV SÜD	CARAT 094465 0004 Rev.00	
Korean Agency for Technology and Standards	KT733	
KOREAN REGISTER OF SHIPPING	PCT40841-TL001	

Remark. This report is not related to KOLAS accreditation and relevant regulation.

## 2. EUT (Equipment Under Test) DESCRIPTION

The Sindoh Co., Ltd., Model D332A (referred to as the EUT in this report) is a Multi Function Peripheral (copier, printer, scanner (optional)). The product specification described herein was obtained from product data sheet or user's manual.

Item	Specifications
Contained WiFi Module in the EUT	FCC ID: PPQ-WN4521L IC ID: 4491A-WN4521L CE: Complied with EN 62368-1, EN 62311, EN 301-489-1/-17, EN 300 328, EN 301 893 Model No: WN4521L Manufacturer: LITE-ON TECHNOLOGY (Changzhou) CO., LTD.
Input Rating	AC 120-127 V, 50-60 Hz, 12 A
Weight	Approx. 154-5/16 lb (70 kg)
Dimension(W x D x H)	22-1/2 inches (571 mm) 26-1/16 inches (661.5 mm) 30-15/16 inches (786 mm) (Up to the surface of Original Grass)
Max Power Consumption	1.5 kW (1.58 kW)
<b>Scanning Function Specifications</b>	
Type	Full-Color Scanner
Scanning resolution	Push: 200 dpi/300 dpi/400 dpi/600 dpi Pull: 100 dpi/200 dpi/300 dpi/400 dpi/600 dpi
Scanning speed	Color and B & W: 55 sheets/min. * Speed when scanning 8-1/2 11(A4) original in 300 dpi mode by using the ADF.
Output format	TIFF, PDF, Compact PDF, PDF/A, Linearized PDF, JPEG, XPS, Compact XPS, OOXML (pptx, xlsx, docx), Searchable PDF
Supported operating systems	Windows 7 *, Windows 8.1 *, Windows 10 * * Supports the 32-bit (x86) or 64-bit (x64) environment.
Driver	TWAIN Driver ,HDD TWAIN Driver
<b>Printer Specifications</b>	
Resolution	1800 dpi (equivalent) 600 dpi (at smoothing)
Page description language	PCL5e/c Emulation PCL6 (XL ver. 3.0) Emulation PostScript 3 Emulation (3016)
Fonts	< PCL > European 80 fonts < PS > European 137 fonts

## 2.1 General Product Information

The EUT is a Multi Function Peripherals (copier, printer, scanner, facsimile (optional)) and has following various options, so the EUT was divided into 3 configurations and explained that at clause 2.1.1 to 2.1.3.

Generic name	Model name	Function	Remarks
Multi function Peripherals	D332A	Machine	EUT
ADF	DF-633	Reverse Automatic Document Feeder	Option
Original Cover <sup>*1)</sup>	OC-513	Original cover for unit	Option
Finisher	FS-539SD	Sorting and Stapling	Option
Finisher	FS-539	Sorting and Stapling	Option
Relay Unit	RU-514	Paper Transportation	Option
Punch KIT	PK-524	Hole Punching	Option
Finisher	FS-533	Sorting and Stapling	Option
Punch KIT	PK-519	Hole Punching	Option
Mount KIT	MK-602	Installation KIT for FS-533	Option
Job Separator	JS-506	Paper Feed Separation	Option
Paper feed cabinet	PC-118	500 sheets Paper feed cabinet	Option
Paper feed cabinet	PC-218	500 sheets x 2 Paper feed cabinet	Option
Paper feed cabinet	PC-418	2500 sheets Paper feed cabinet	Option
Power Box Unit	MK-734	Supply Box for Heater kit	Option
Dehumidifier	HT-509	Heater for dehumidification	Option
Desk <sup>*1)</sup>	DK-518	Copy Desk for unit	Option
Clean Unit	CU-101	UFP cleaning module	Option
Mount Kit	MK-748	Installation Mount Kit for CU-101	Option
Working Table <sup>*1)</sup>	WT-515	Working Table for unit	Option
Mount Kit	MK-603	Paper Sorting	Option
Local Interface Kit	EK-609	USB connection and Bluetooth	Option
Local Interface Kit	EK-608	USB connection	Option
Fax KIT	FK-513	Facsimile function	Option
Wireless LAN	UK-221	Wireless function Kit	Option
Biometric Authentication	AU-102	Authentication security(Biometric type)	Option
IC Card Authentication	AU-201S	Authentication security(Card type)	Option
Mount Kit	MK-735	Installation Kit for AU-201S	Option
SSD	EM-907	Expand storage	Option
Keypad	KP-101	Key pad for operation panel	Option
Key counter	Key Counter Mount Kit 1	Paper Counter	Option

\*1) : No electrical components



### 2.1.1 EUT 1 Configuration

The EUT 1 is consist with following options

Generic name	Model name	Function	Remarks
Multi function Peripherals	D332A	Machine	EUT
ADF	DF-633	Reverse Automatic Document Feeder	Option
Finisher	FS-539SD	Sorting and Stapling	Option
Relay Unit	RU-514	Paper Transportation	Option
Punch KIT	PK-524	Hole Punching	Option
Paper feed cabinet	PC-418	2500 sheets Paper feed cabinet	Option
Power Box Unit	MK-734	Supply Box for Heater kit	Option
Dehumidifier	HT-509	Heater for dehumidification	Option
Clean Unit	CU-101	UFP cleaning module	Option
Mount Kit	MK-748	Installation Mount Kit for CU-101	Option
Mount Kit	MK-603	Paper Sorting	Option
Local Interface Kit	EK-609	USB connection and Bluetooth	Option
Fax KIT	FK-513	Facsimile function	Option
Wireless LAN	UK-221	Wireless function Kit	Option
SSD	EM-907	Expand storage	Option
Keypad	KP-101	Key pad for operation panel	Option

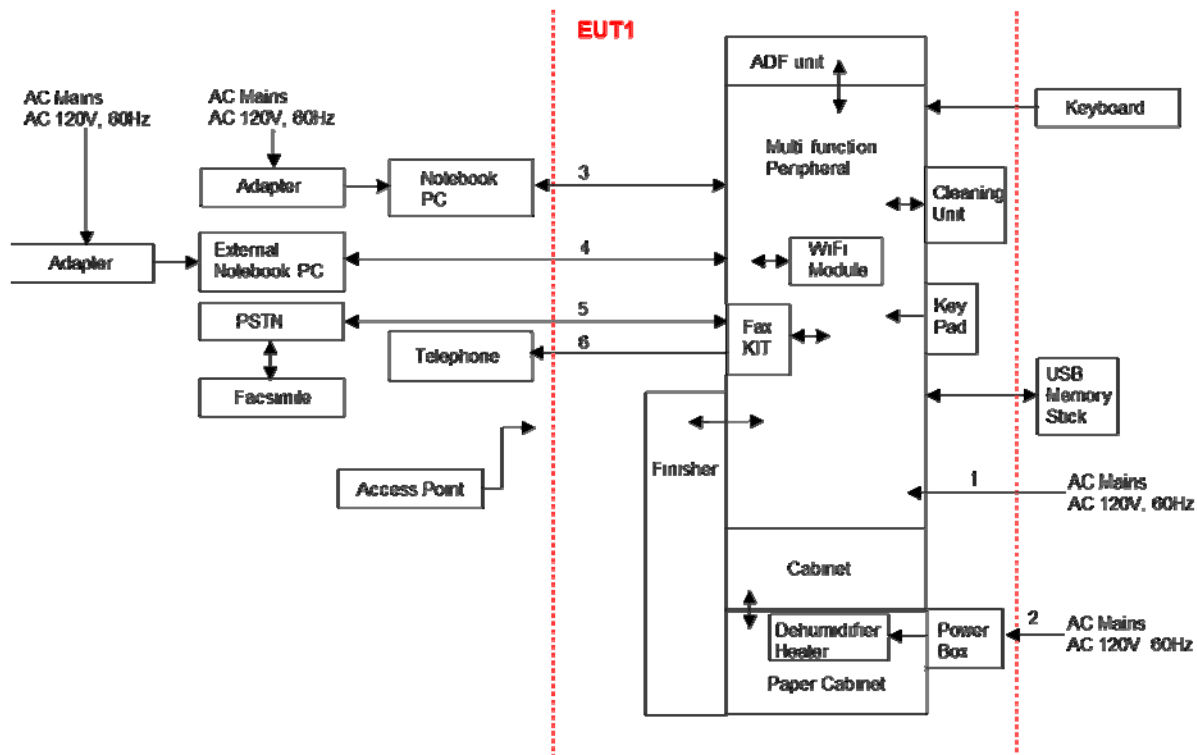

## 2.1.2 EUT 2 Configuration

The EUT 2 is consist with following options

Generic name	Model name	Function	Remarks
Multi function Peripherals	D332A	Machine	EUT
ADF	DF-633	Reverse Automatic Document Feeder	Option
Finisher	FS-533	Sorting and Stapling	Option
Punch KIT	PK-519	Hole Punching	Option
Mount KIT	MK-602	Installation KIT for FS-533	Option
Paper feed cabinet	PC-218	500 sheets x 2 Paper feed cabinet	Option
Power Box Unit	MK-734	Supply Box for Heater kit	Option
Dehumidifier	HT-509	Heater for dehumidification	Option
Working Table	WT-515	Working Table for unit	Option
Mount Kit	MK-603	Paper Sorting	Option
Local Interface Kit	EK-609	USB connection and Bluetooth	Option
Fax KIT	FK-513	Facsimile function	Option
Wireless LAN	UK-221	Wireless function Kit	Option
Biometric Authentication	AU-102	Authentication security(Biometric type)	Option
SSD	EM-907	Expand storage	Option
Keypad	KP-101	Key pad for operation panel	Option
Key counter	Key Counter Mount Kit 1	Paper Counter	Option

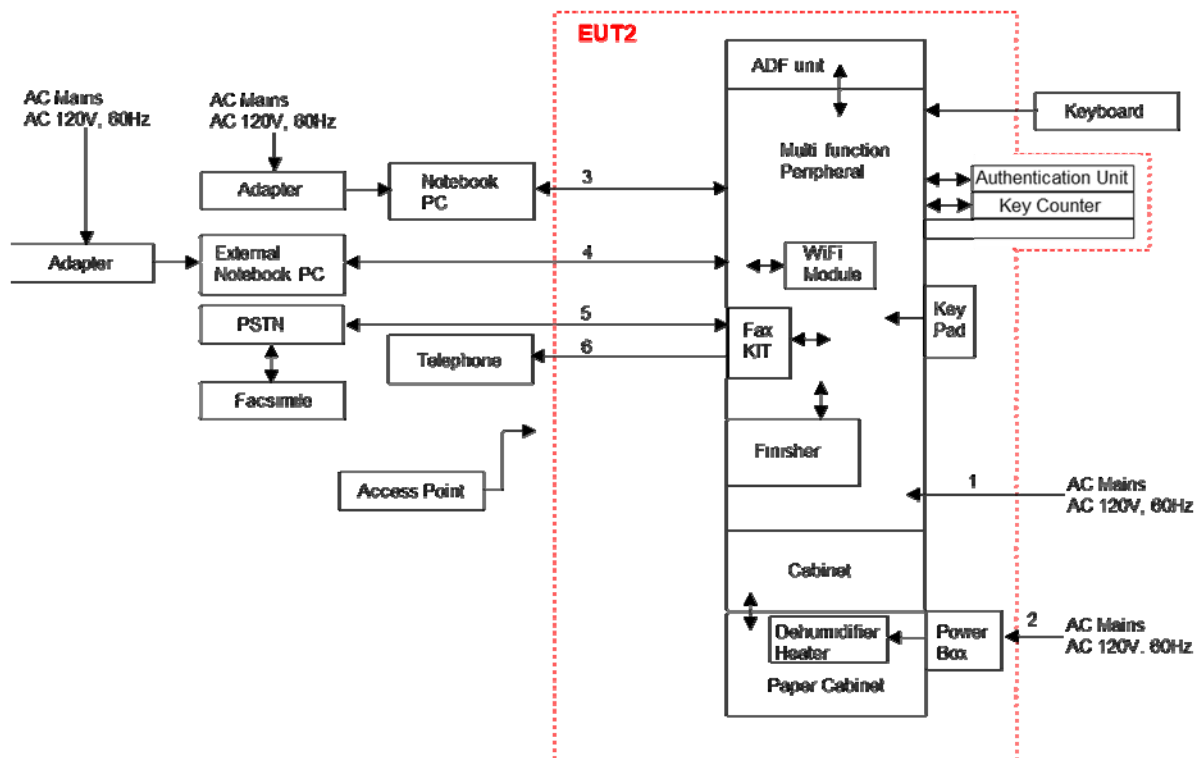

### 2.1.3 EUT 3 Configuration

The EUT 3 is consist with following options

Generic name	Model name	Function	Remarks
Multi function Peripherals	D332A	Machine	EUT
ADF	DF-633	Reverse Automatic Document Feeder	Option
Job Separator	JS-506	Paper Feed Separation	Option
Paper feed cabinet	PC-218	500 sheets x 2 Paper feed cabinet	Option
Power Box Unit	MK-734	Supply Box for Heater kit	Option
Dehumidifier	HT-509	Heater for dehumidification	Option
Working Table	WT-515	Working Table for unit	Option
Mount Kit	MK-603	Paper Sorting	Option
Local Interface Kit	EK-609	USB connection and Bluetooth	Option
Fax KIT	FK-513	Facsimile function	Option
Wireless LAN	UK-221	Wireless function Kit	Option
IC Card Authentication	AU-201S	Authentication security(Card type)	Option
Mount Kit	MK-735	Installation Kit for AU-201S	Option
SSD	EM-907	Expand storage	Option
Keypad	KP-101	Key pad for operation panel	Option
Key counter	Key Counter Mount Kit 1	Paper Counter	Option

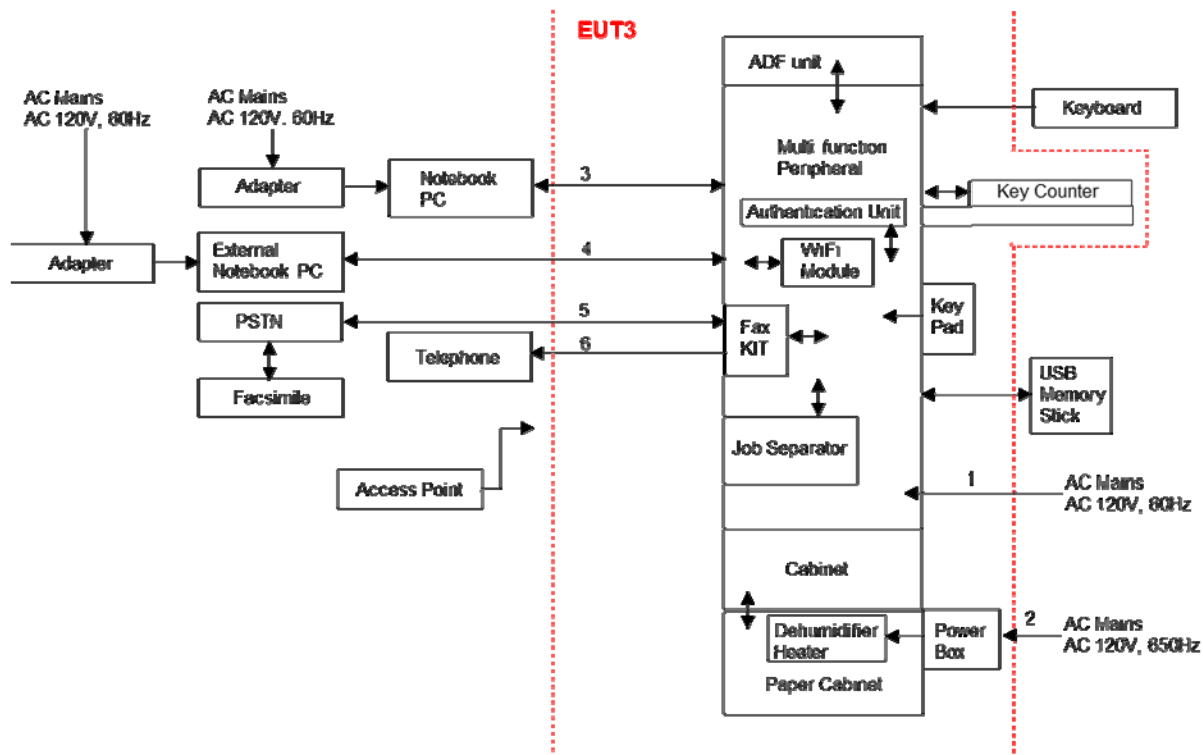

## 2.2 Additional Model

Model Name	Model Difference
D332A	Basic Model, print speed [28 PPM]
D331A	Identical to basic model, except for model name and print speed [25 PPM]
D330A	Identical to basic model, except for model name and print speed [22 PPM]

Note: The manufacturer has declared to all the additional model names into basic model name without any further evaluation by ENG Co., Ltd.

### 3. TEST CONDITION

#### 3.1 Equipment Used During Test

The following peripheral devices and/or interface cables were connected during the measurement:

Description	Model No.	Serial No.	Manufacturer.
Multi Function Peripheral (copier, printer, scanner (optional) (EUT)	D332A	ACM1041901011	Sindoh Co., Ltd.
Notebook PC 1	TRN-C125	CND6292M0C	HP
Adapter for Notebook PC 1	HSTNN-CA40	N/A	CHICONY POWER Technology
Notebook PC 2	TRN-C125	CND6292LB7	HP
Adapter for Notebook PC 2	HSTNN-CA40	N/A	CHICONY POWER Technology
Access Point	AW-A1	ABRE400675NT	Unicorn Information System
Adapter for Access Point	KA02-1201000	N/A	Shenzhen Keyu Power Supply Technology Co., Ltd.
Telephone	VT-3200	N/A	SHENZHEN DAERXUN
Facsimile	D332A	ACM1041901002	Sindoh Co., Ltd.
Keyboard	DK-100M	N/A	DD ZONE
USB Memory Stick	SDCZ48-016G	N/A	SANDISK

#### 3.2 Cable Description

Description	Ports Name	Shielded (Y/N)	Ferrite Bead (Y/N)	Length (m)	Connected to
EUT	AC Mains Input	N	N	2.5	AC Mains
	AC Mains Input (For Dehumidifier Heater)	N	N	2.5	
	USB (Type B)	Y	N	5.0	Notebook PC 1
	USB	Y	N	1.2	Keyboard
	LAN Cable (RJ45)	Y	N	> 3.0	Notebook PC 2
	FAX Line (RJ11C)	N	N	> 10.0	PSTN
	Telephone	N	N	2.0	Telephone

### 3.3 Operating mode of the EUT

The EUT is a multi functional device, so following modes were investigated during the testing

Mode	Function	Description
A	UBS Print	The following operations are repeated continuously during the tests. 1. Receiving a print data from via USB I/F the PC. 2. Feeding a paper from paper tray. 3. Printing received data to both side of paper. 4. Outputting a printed paper to the output tray of Finisher FS-539. 5. Continuous Ping command via LAN Cable from the PC. Speed : 1Gbps 6. Continuous Ping command via AP from the PC. IEEE802.11ac(40 MHz)
B	LAN Print	The following operations are repeated continuously during the tests. 1. Receiving a print data via a Ethernet from the PC. 2. Feeding a paper from paper tray. 3. Printing received data to both side of paper. 4. Outputting a printed paper to the output tray of Finisher FS-539.. 5. Continuous Ping command via LAN Cable from the PC. Speed : 1Gbps 6. Continuous Ping command via AP from the PC. IEEE802.11 ac(40 MHz)
C	WiFi Print (2.4G)	The following operations are repeated continuously during the tests. 1. Receiving a print data via AP from the PC. 2. Feeding a paper from paper tray. 3. Printing received data to both side of paper. 4. Outputting a printed paper to the output tray of Finisher FS-533.. 5. Continuous Ping command via LAN Cable from the PC. Speed : 1Gbps 6. Continuous Ping command via AP from the PC. IEEE802.11 b
D	WiFi Print (5G)	The following operations are repeated continuously during the tests. 1. Receiving a print data via AP from the PC. 2. Feeding a paper from paper tray. 3. Printing received data to both side of paper. 4. Outputting a printed paper to the output tray of Finisher FS-539. 5. Continuous Ping command via LAN Cable from the PC. Speed : 1Gbps 6. Continuous Ping command via AP from the PC. IEEE802.11 ac(40MHz)
E	USB Memory Stick Print	The following operations are repeated continuously during the tests. 1. Receiving print data from USB Memory Stick. 2. Feeding a paper from paper tray. 3. Printing a received data to both side of paper. 4. Outputting a printed paper to the output tray of JS-506. 5. Continuous Ping command via LAN Cable from the PC. Speed : 1Gbps 6. Continuous Ping command via AP from the PC. IEEE802.11 ac(40 MHz)

Mode	Function	Description
F	Copy	The following operations are repeated continuously during the tests. 1. Both sides of the original (A4 size) are scanned at a time. 2. Feeding a paper from paper tray. 3. Printing received data to both side of paper. 4. Printed paper is made with punch holes and stapled. 5. Outputting a printed paper to the output tray of Finisher FS-539. 6. Continuous Ping command via LAN Cable from the PC. Speed : 1Gbps 7. Continuous Ping command via AP from the PC. IEEE802.11ac(40 MHz)
G	LAN Scan	The following operations are repeated continuously during the tests. 1. Scanning the image via ADF(DF-633) of EUT. 2. Sending scanning data via a Ethernet from EUT to the PC. Speed : 1Gbps 3. Receiving scanning data in PC 4. Continuous Ping command via AP from the PC. IEEE802.11 ac(40 MHz)
H	WiFi Scan (2.4G)	The following operations are repeated continuously during the tests. 1. Scanning the image via ADF(DF-633) of EUT. 2. Sending a scanning data via AP from EUT to the PC. IEEE802.11 b 3. Receiving scanning data in PC 4. Continuous Ping command via LAN Cable from the PC. Speed : 1Gbps
I	WiFi Scan (5G)	The following operations are repeated continuously during the tests. 1. Scanning the image via ADF(DF-633) of EUT. 2. Sending a scanning data via AP from EUT to the PC. IEEE802.11 ac(40 MHz) 3. Receiving scanning data in PC 4. Continuous Ping command via LAN Cable from the PC. Speed : 1Gbps
J	USB Memory Stick Scan	The following operations are repeated continuously during the tests. 1. Scanning the image via ADF(DF-633) of EUT. 2. Sending scanning data to USB Memory Stick. 3. Saving scanning data in USB Memory Stick. 4. Continuous Ping command via LAN Cable from the PC. Speed : 1Gbps 5. Continuous Ping command via AP from the PC. IEEE802.11 ac(40 MHz)
K	Fax Tx	The following operations are repeated continuously during the tests. 1. Scanning the original 2. Sending the scanned data via a Tel I/F to FAX Kit 3. Continuous Ping command via LAN Cable from the PC. Speed : 1Gbps 4. Continuous Ping command via AP from the PC. IEEE802.11 ac(40 MHz)
L	Fax Rx	The following operations are repeated continuously during the tests. 1. Receiving a FAX data via a Tel I/F from the FAX Kit 2. Feeding a paper from paper tray. 3. Printing a received data to paper. 4. Outputting a printed paper to the output tray of Finisher FS-539. 5. Continuous Ping command via LAN Cable from the PC. Speed : 1Gbps 6. Continuous Ping command via AP from the PC. IEEE802.11 ac(40 MHz)

### 3.4 Mode of operation during the test

Following operating modes were tested at each EUT's configuration.

Operating modes				
Test Name	Test Port	EUT Configuration		
		EUT1	EUT2	EUT3
Conducted Emission	AC Mains Port #1	A, B, D, F, H, J, K, L	C, G	E, I
	AC Mains Port #2	A	No Test	No Test
Radiated Emission	Enclosure	A, B, D, F, H, J, K, L	C, G	E, I

Remark. For testing of EUT 2 configuration, USB memory stick was not inserted into the EUT.



### 3.5 Test Setup Drawing

[Conducted Emission for EUT #1, and EUT #3]

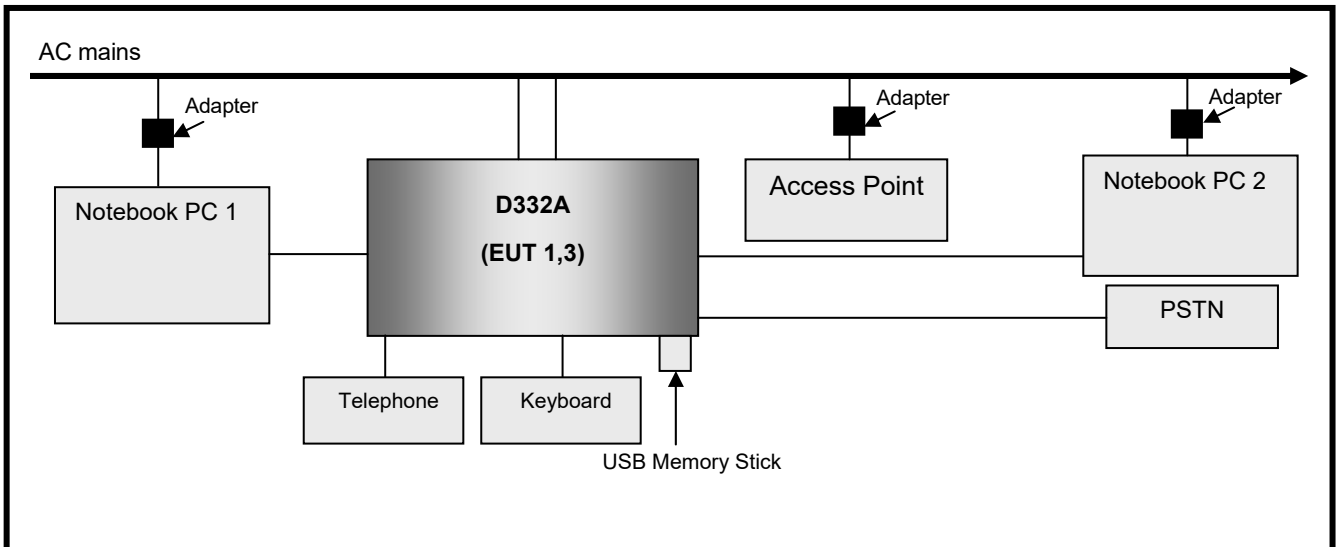

[Radiated Emission for EUT #1, and EUT #3]

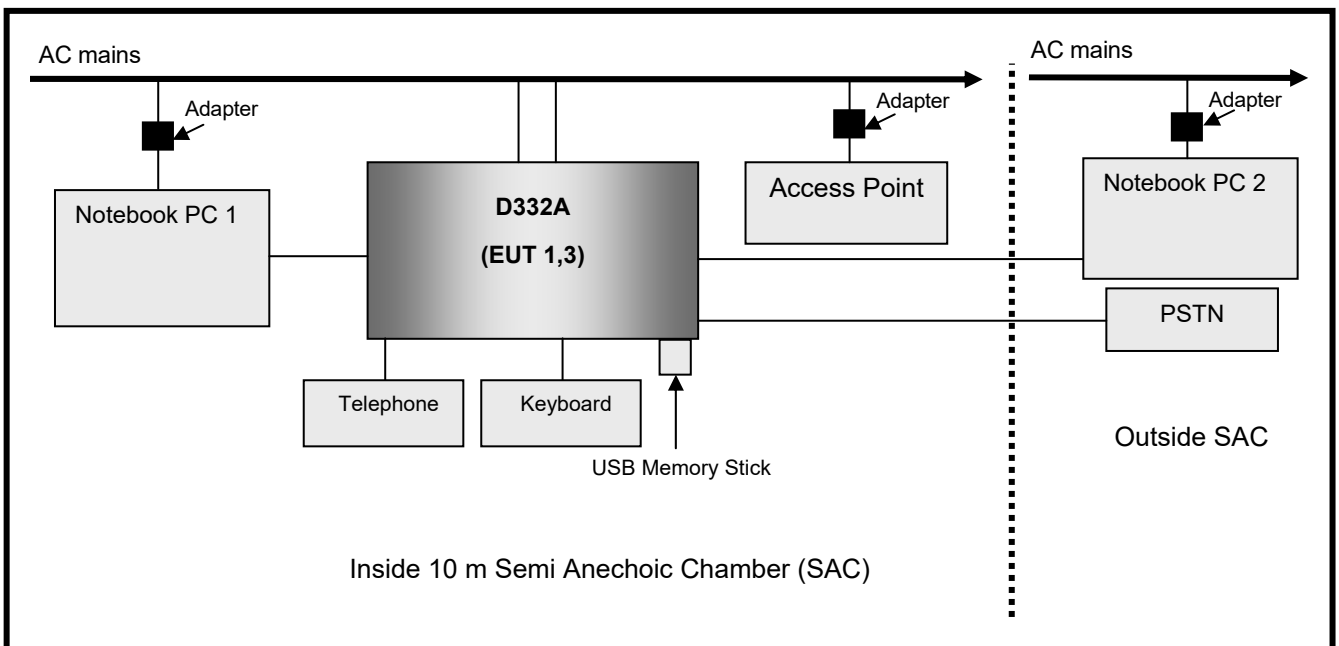

**[Conducted Emission for EUT #2]**

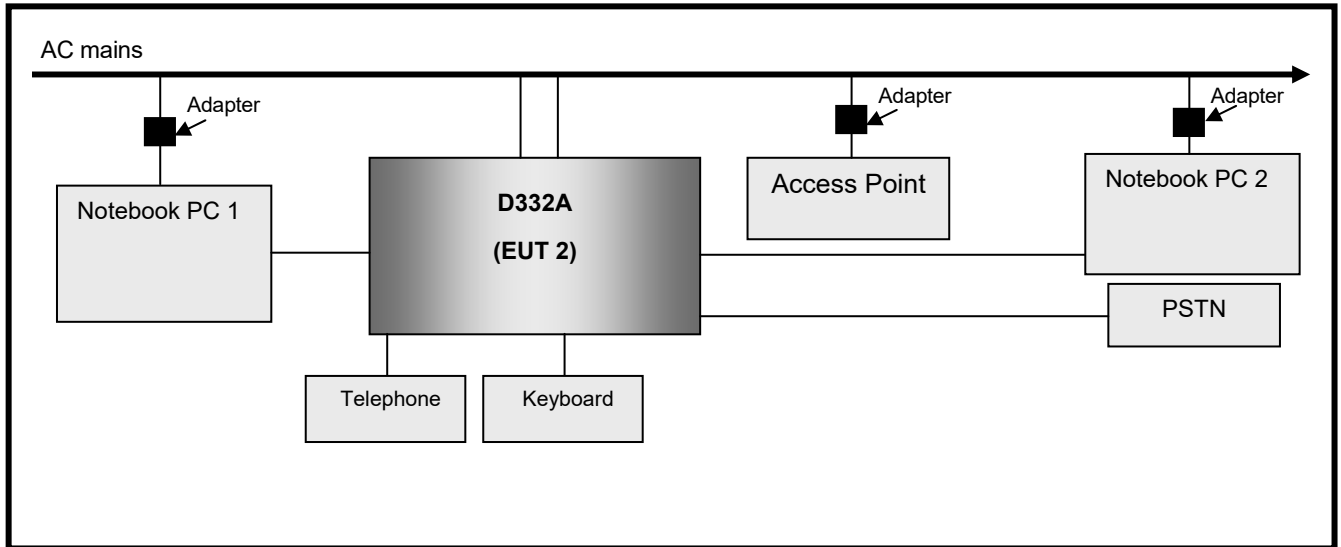

**[Radiated Emission for EUT #2]**

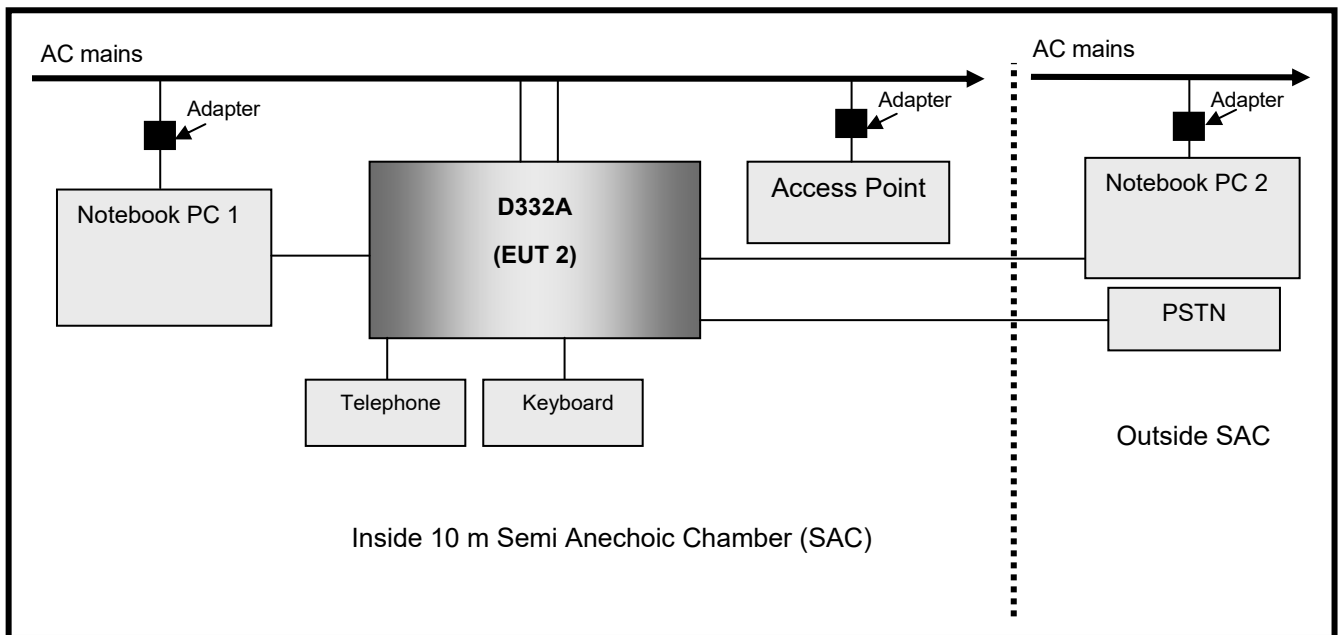

**4. EUT MODIFICATIONS**

- No EMC Relevant Modifications were performed by this test laboratory.

## 5. EMISSION TESTS

### 5.1 AC Power Line Conducted Emission

#### 5.1.1 Test setup

The EUT and all supporting equipments were placed on a non-metallic table approximately 0.8 m above the ground plane.

Power was fed to the EUT through a 50 Ω/50 μH + 5 Ω Line Impedance Stabilization Network (LISN) and all supporting equipments were connected to another LISN. The ground plane was electrically bonded to the reference ground system and all power lines were filtered from ambient noise. Preliminary Power line Conducted Emission test was performed by using the procedure in ANSI C63.4: 2014 7.3.3 to determine the worse operating conditions.

The test set-up photos are included in appendix I.

Used Software for measurement is EMC 32 supplied by Rohde&Schwarz.

#### 5.1.2 Measurement uncertainty

Frequency range	Uncertainty
150 kHz ~ 30 MHz	2.01 dB

The measurement uncertainties are given with 95 % confidence.

#### 5.1.3 Test Result

Date of Test	2020-06-09 ~ 06-29		
Temperature	(22.4 ± 2.4) °C	Relative humidity	(47.15 ± 4.75) % R.H.
Operating Input Voltage	120 Vac	Input Frequency	60 Hz
Frequency range	RBW	VBW	Detector Mode
0.15 MHz ~ 30 MHz	9 kHz	30 kHz	Peak , Q.P and/or Average
Test Mode	Mode A ~ L		
<b>Test Result</b>	<b>Pass</b>	Tested By	Chu, Woo-Sik

#### 5.1.4 Sample Calculated Example

At 5.31 MHz

QP Limit = 73.0 dBμV

Correction Factor (C. Factor) of LISN, Pulse Limiter and cable loss at 5.31 MHz = 9.7 dB

Q.P Reading from the Test receiver = 40.8 dBμV

(Calculated value for system losses by software EMC32 manufactured by Rohde & Schwarz)

Therefore Q.P Margin = 73 - 40.8 = 32.2

so the EUT has 32.2 dB margin at 5.31 MHz

### 5.1.5 Test Data

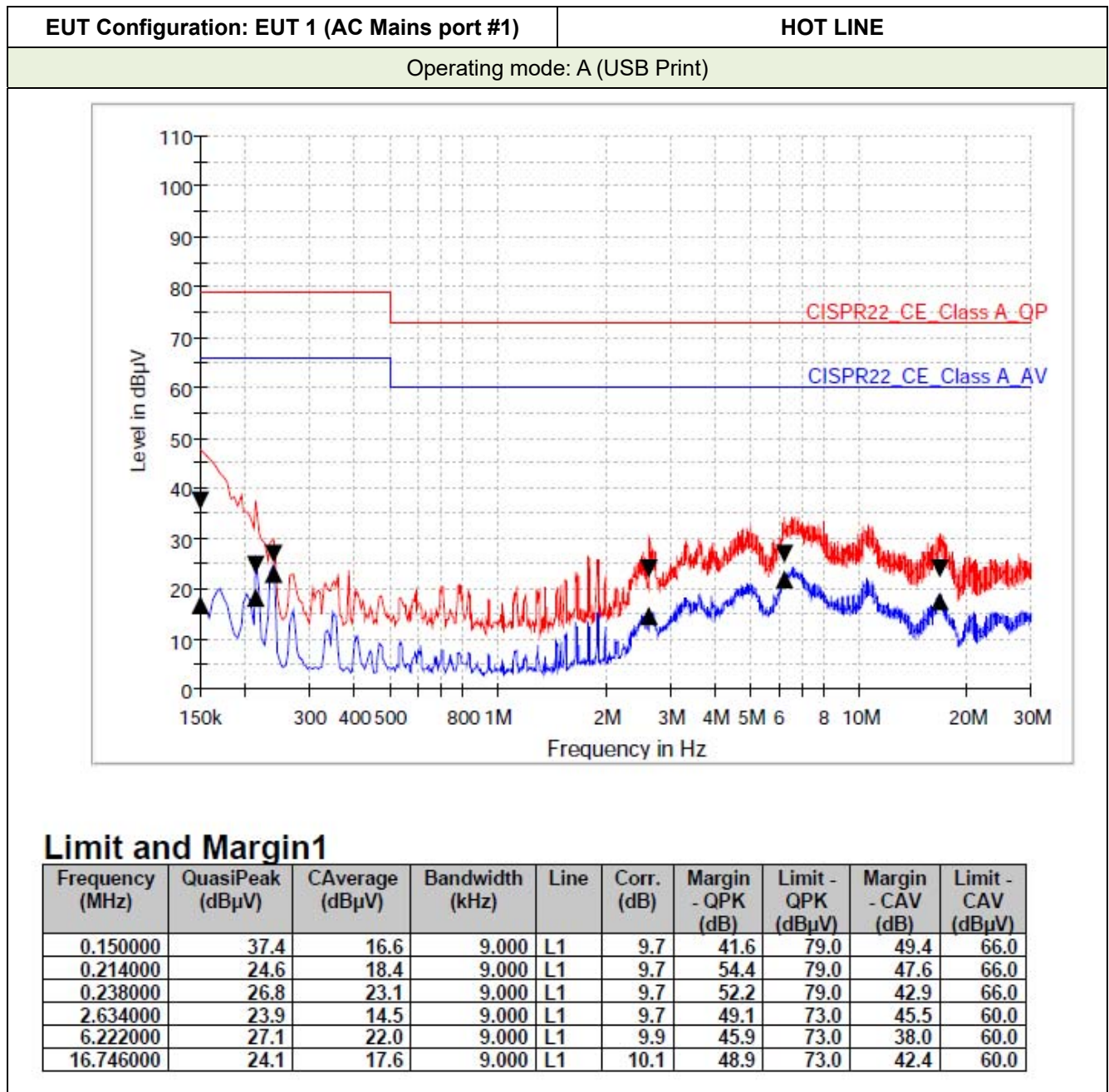

EUT Configuration: EUT 1 (AC Mains port #1)

NEUTRAL LINE

Operating mode: A (USB Print)

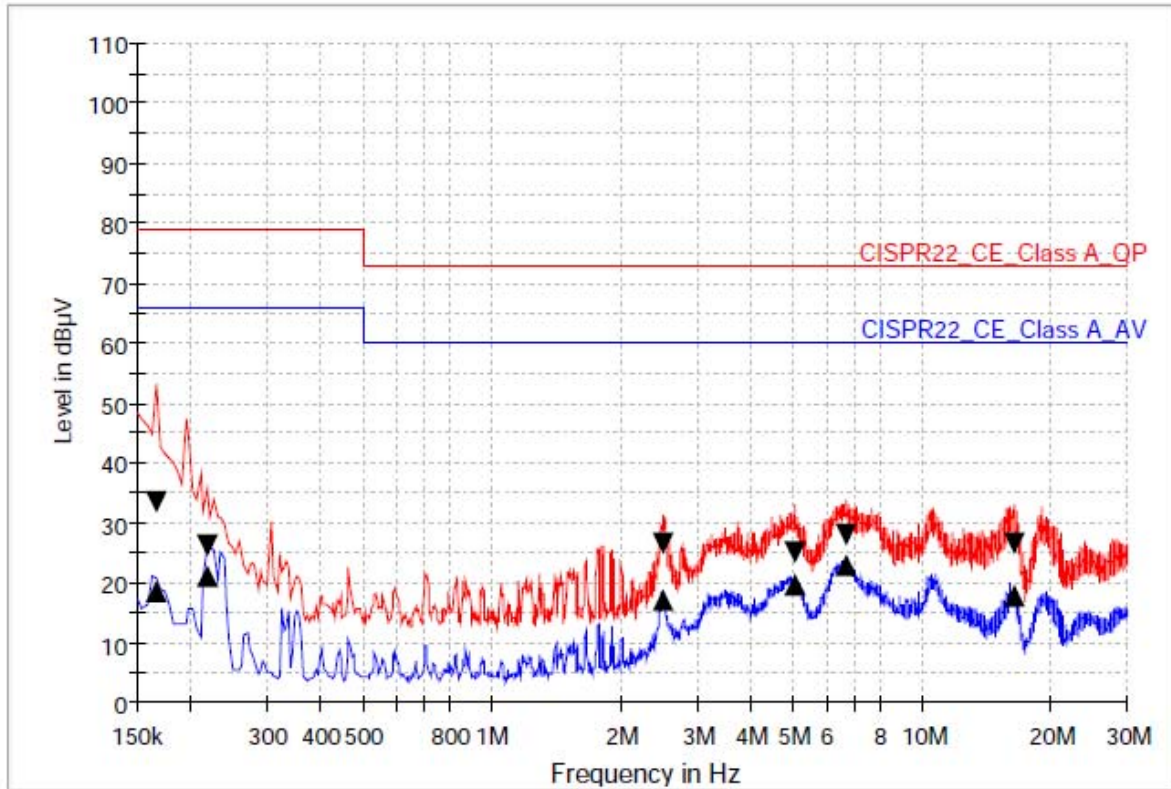

### Limit and Margin1

Frequency (MHz)	QuasiPeak (dBµV)	CAverage (dBµV)	Bandwidth (kHz)	Line	Corr. (dB)	Margin - QPK (dB)	Limit - QPK (dBµV)	Margin - CAV (dB)	Limit - CAV (dBµV)
0.166000	33.6	18.7	9.000	N	9.7	45.4	79.0	47.3	66.0
0.218000	26.3	21.1	9.000	N	9.7	52.7	79.0	44.9	66.0
2.502000	26.6	17.0	9.000	N	9.7	46.4	73.0	43.0	60.0
5.050000	25.1	19.6	9.000	N	9.8	47.9	73.0	40.4	60.0
6.650000	28.2	22.9	9.000	N	9.9	44.8	73.0	37.1	60.0
16.334000	26.6	18.0	9.000	N	10.1	46.4	73.0	42.0	60.0

EUT Configuration: EUT 1 (AC Mains port #2)

HOT LINE

Operating mode: A (USB Print)

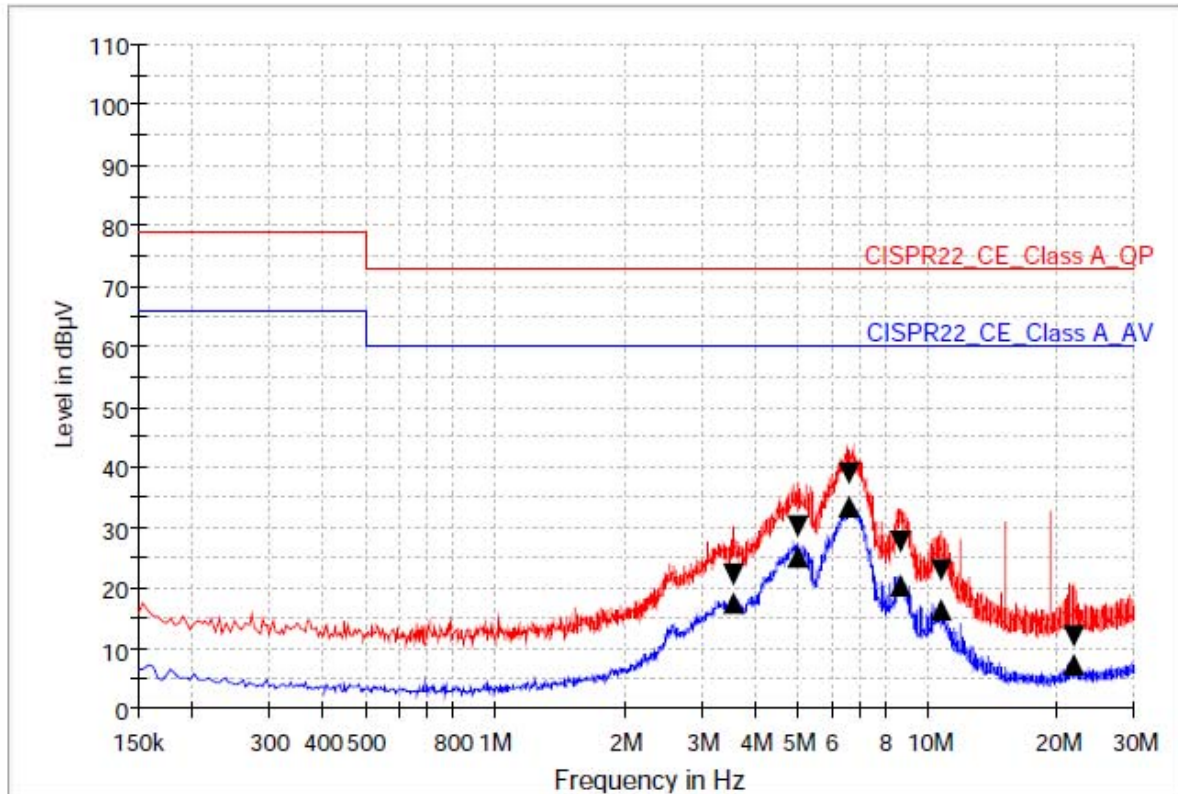

### Limit and Margin1

Frequency (MHz)	QuasiPeak (dBµV)	CAverage (dBµV)	Bandwidth (kHz)	Line	Corr. (dB)	Margin - QPK (dB)	Limit - QPK (dBµV)	Margin - CAV (dB)	Limit - CAV (dBµV)
3.566000	22.2	17.6	9.000	L1	9.8	50.8	73.0	42.4	60.0
5.018000	30.4	25.3	9.000	L1	9.8	42.6	73.0	34.7	60.0
6.598000	38.9	33.5	9.000	L1	9.9	34.2	73.0	26.5	60.0
8.706000	27.9	20.6	9.000	L1	10.0	45.1	73.0	39.4	60.0
10.718000	22.8	16.3	9.000	L1	10.1	50.2	73.0	43.7	60.0
21.814000	11.9	7.2	9.000	L1	10.2	61.1	73.0	52.8	60.0

EUT Configuration: EUT 1 (AC Mains port #2)

NEUTRAL LINE

Operating mode: A (USB Print)

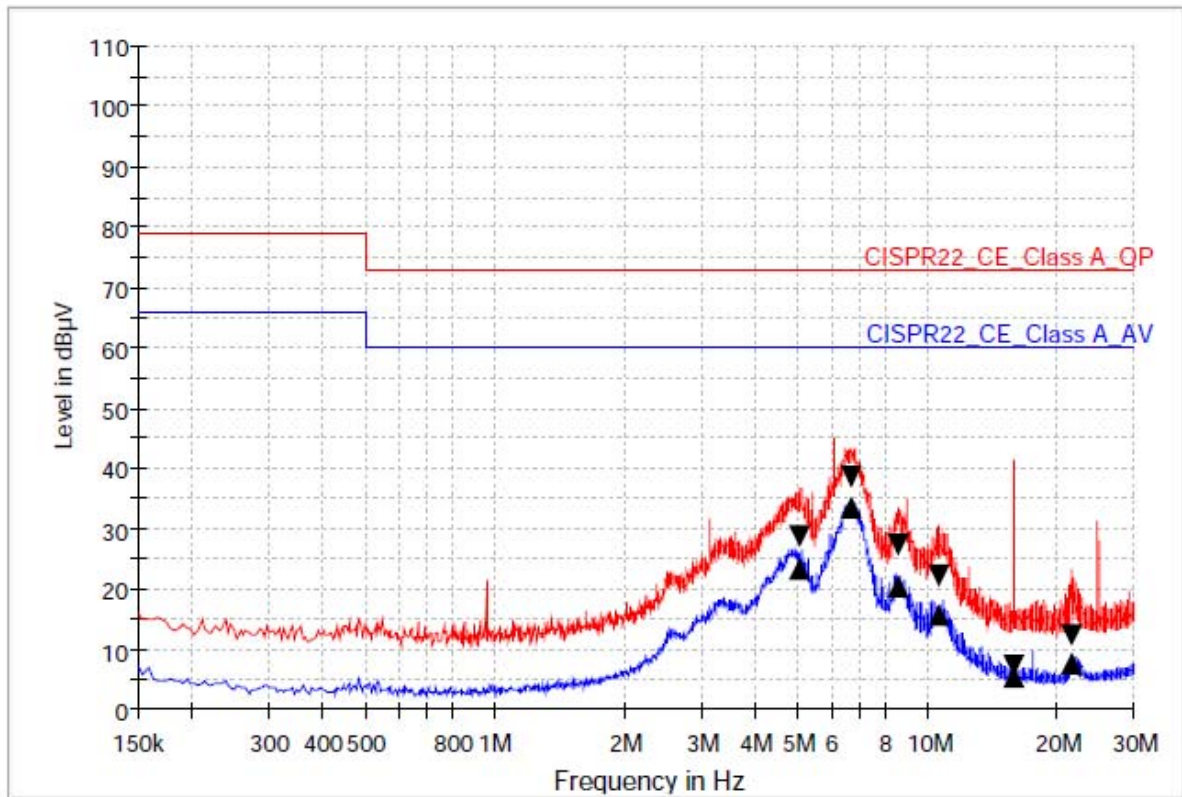

### Limit and Margin1

Frequency (MHz)	QuasiPeak (dBµV)	CAverage (dBµV)	Bandwidth (kHz)	Line	Corr. (dB)	Margin - QPK (dB)	Limit - QPK (dBµV)	Margin - CAV (dB)	Limit - CAV (dBµV)
5.058000	28.8	23.4	9.000	N	9.8	44.2	73.0	36.6	60.0
6.658000	38.7	33.4	9.000	N	9.9	34.3	73.0	26.6	60.0
8.610000	27.4	20.4	9.000	N	10.0	45.6	73.0	39.6	60.0
10.618000	22.3	15.6	9.000	N	10.1	50.7	73.0	44.4	60.0
15.790000	7.2	5.4	9.000	N	10.1	65.8	73.0	54.6	60.0
21.554000	12.3	7.5	9.000	N	10.2	60.7	73.0	52.5	60.0

EUT Configuration: EUT 1 (AC Mains port #1)

HOT LINE

Operating mode: B (LAN Print)

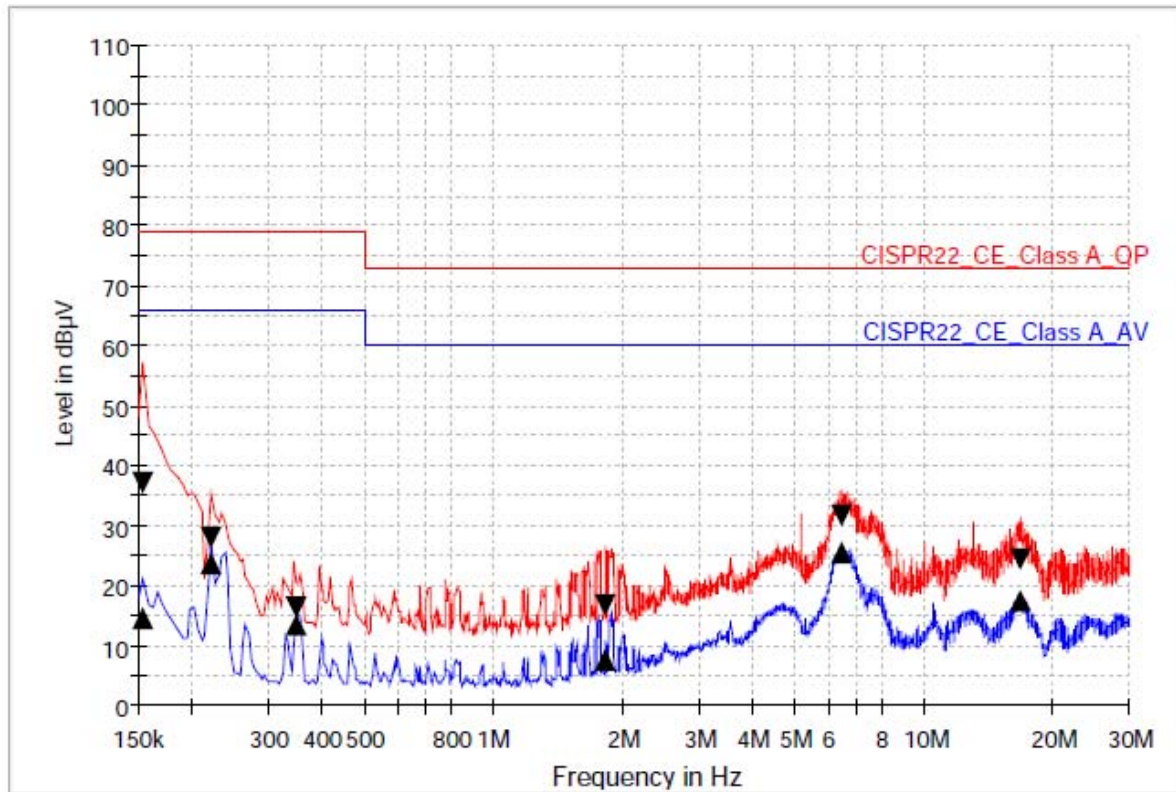

### Limit and Margin1

Frequency (MHz)	QuasiPeak (dBµV)	CAverage (dBµV)	Bandwidth (kHz)	Line	Corr. (dB)	Margin - QPK (dB)	Limit - QPK (dBµV)	Margin - CAV (dB)	Limit - CAV (dBµV)
0.154000	37.1	14.6	9.000	L1	9.7	41.9	79.0	51.4	66.0
0.222000	28.2	23.9	9.000	L1	9.7	50.8	79.0	42.1	66.0
0.350000	16.3	13.5	9.000	L1	9.7	62.7	79.0	52.5	66.0
1.826000	16.9	7.6	9.000	L1	9.7	56.1	73.0	52.4	60.0
6.470000	31.7	25.6	9.000	L1	9.9	41.3	73.0	34.4	60.0
16.730000	24.3	17.6	9.000	L1	10.1	48.7	73.0	42.4	60.0



EUT Configuration: EUT 1 (AC Mains port #1)

NEUTRAL LINE

Operating mode: B (LAN Print)

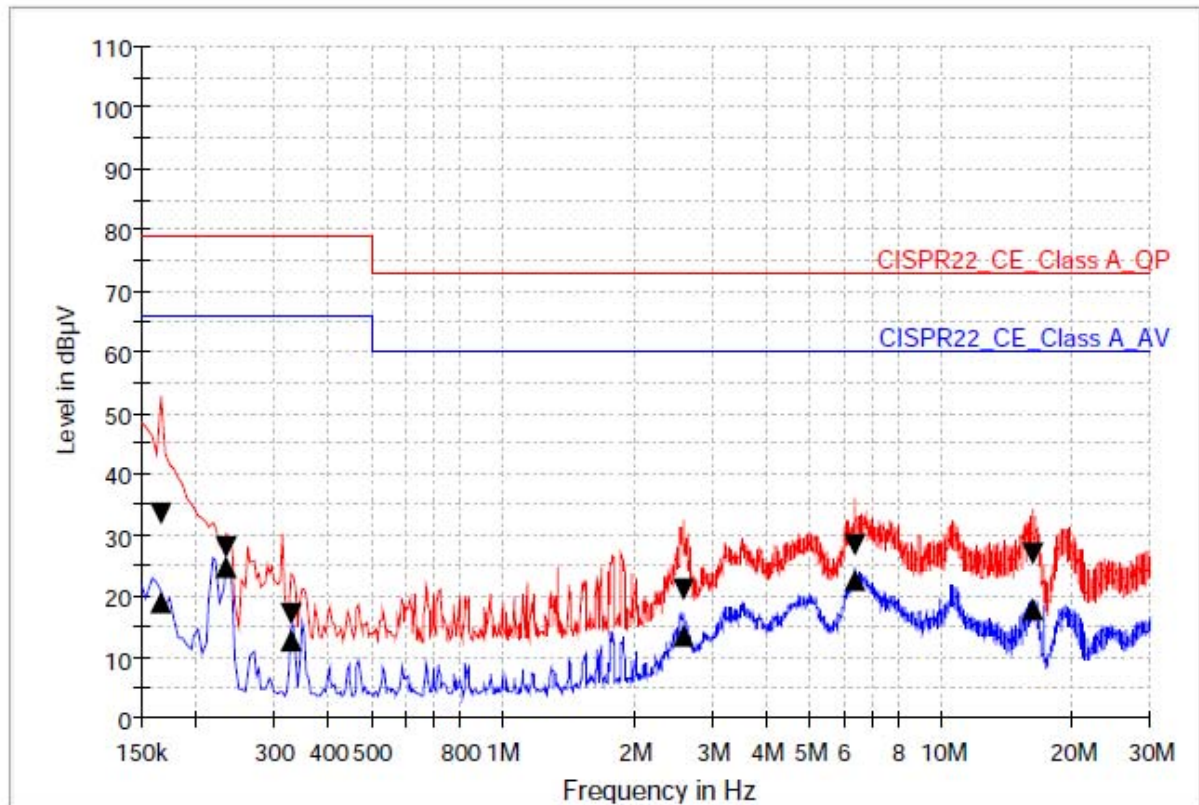

### Limit and Margin1

Frequency (MHz)	QuasiPeak (dBµV)	CAverage (dBµV)	Bandwidth (kHz)	Line	Corr. (dB)	Margin - QPK (dB)	Limit - QPK (dBµV)	Margin - CAV (dB)	Limit - CAV (dBµV)
0.166000	33.5	19.1	9.000	N	9.7	45.5	79.0	46.9	66.0
0.234000	28.0	24.9	9.000	N	9.7	51.0	79.0	41.1	66.0
0.330000	17.3	12.6	9.000	N	9.7	61.7	79.0	53.4	66.0
2.582000	21.3	13.5	9.000	N	9.7	51.7	73.0	46.5	60.0
6.350000	28.3	22.7	9.000	N	9.9	44.7	73.0	37.3	60.0
16.170000	27.0	18.0	9.000	N	10.1	46.0	73.0	42.0	60.0

EUT Configuration: EUT 1 (AC Mains port #1)

HOT LINE

Operating mode: D(WiFi Print (5 G))

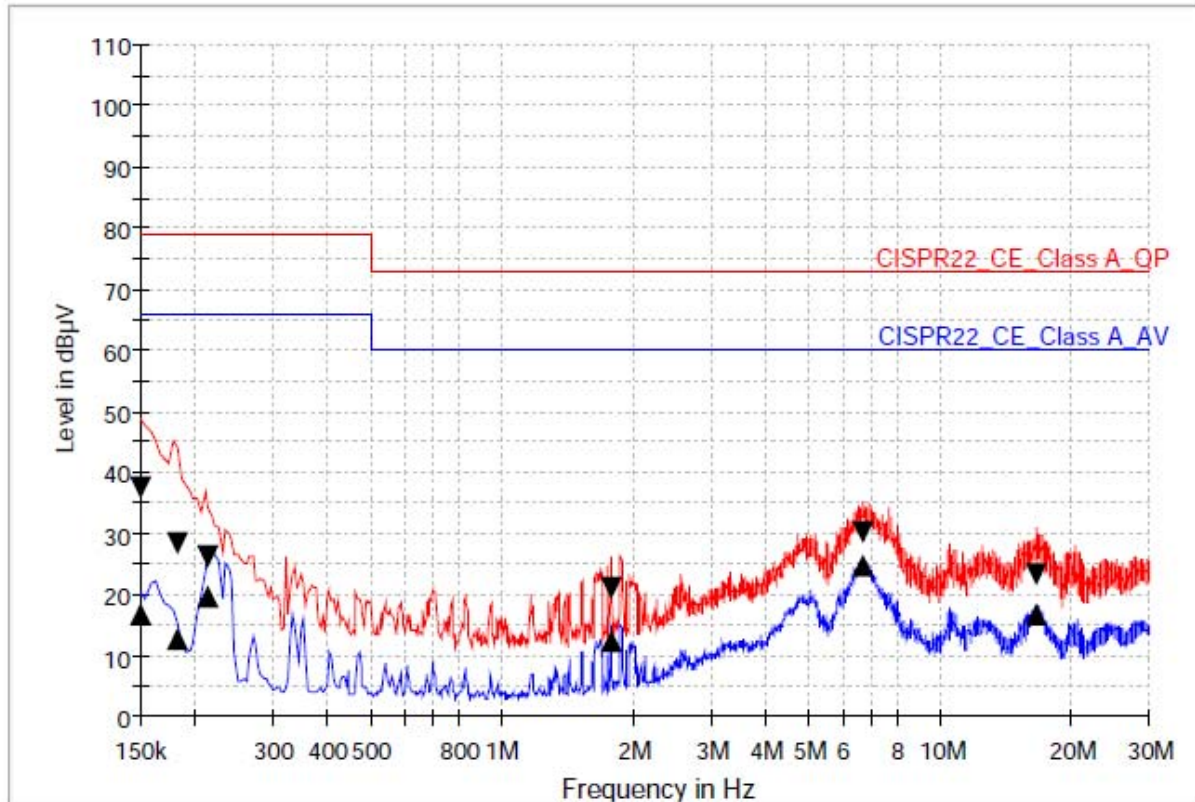

### Limit and Margin1

Frequency (MHz)	QuasiPeak (dBµV)	CAverage (dBµV)	Bandwidth (kHz)	Line	Corr. (dB)	Margin - QPK (dB)	Limit - QPK (dBµV)	Margin - CAV (dB)	Limit - CAV (dBµV)
0.150000	37.4	16.8	9.000	L1	9.7	41.6	79.0	49.2	66.0
0.182000	28.3	12.7	9.000	L1	9.7	50.7	79.0	53.3	66.0
0.214000	26.2	19.6	9.000	L1	9.7	52.8	79.0	46.4	66.0
1.778000	21.3	12.6	9.000	L1	9.7	51.7	73.0	47.4	60.0
6.678000	30.2	24.9	9.000	L1	9.9	42.8	73.0	35.1	60.0
16.658000	23.3	16.8	9.000	L1	10.1	49.7	73.0	43.2	60.0

EUT Configuration: EUT 1 (AC Mains port #1)

NEUTRAL LINE

Operating mode: D(WiFi Print (5 G))

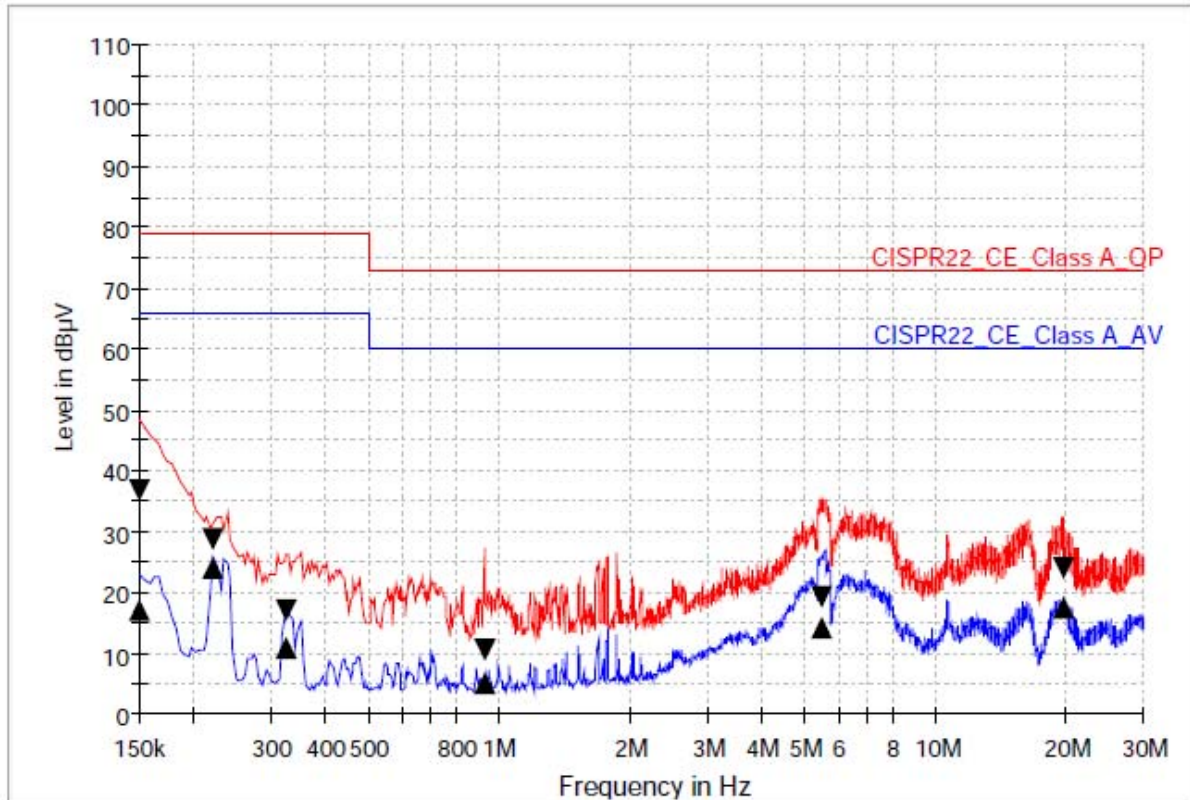

### Limit and Margin1

Frequency (MHz)	QuasiPeak (dBµV)	CAverage (dBµV)	Bandwidth (kHz)	Line	Corr. (dB)	Margin - QPK (dB)	Limit - QPK (dBµV)	Margin - CAV (dB)	Limit - CAV (dBµV)
0.150000	36.8	17.1	9.000	N	9.7	42.2	79.0	48.9	66.0
0.222000	28.6	24.2	9.000	N	9.7	50.4	79.0	41.8	66.0
0.326000	17.1	10.8	9.000	N	9.7	61.9	79.0	55.2	66.0
0.926000	10.4	5.0	9.000	N	9.7	62.6	73.0	55.0	60.0
5.478000	19.2	14.3	9.000	N	9.8	53.8	73.0	45.7	60.0
19.662000	24.0	17.4	9.000	N	10.2	49.0	73.0	42.6	60.0

EUT Configuration: EUT 1 (AC Mains port #1)

HOT LINE

Operating mode: F(Copy)

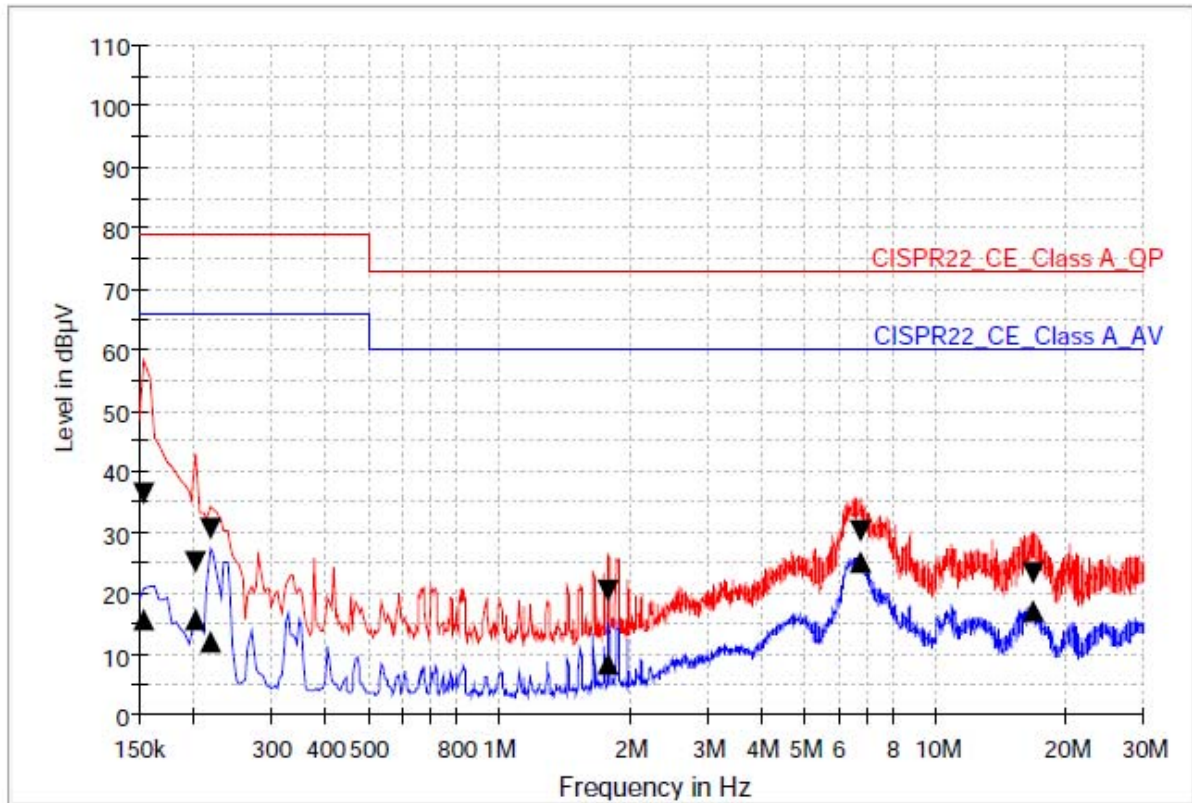

### Limit and Margin1

Frequency (MHz)	QuasiPeak (dBµV)	CAverage (dBµV)	Bandwidth (kHz)	Line	Corr. (dB)	Margin - QPK (dB)	Limit - QPK (dBµV)	Margin - CAV (dB)	Limit - CAV (dBµV)
0.154000	36.6	15.8	9.000	L1	9.7	42.4	79.0	50.2	66.0
0.202000	25.1	15.8	9.000	L1	9.7	53.9	79.0	50.2	66.0
0.218000	30.8	12.2	9.000	L1	9.7	48.2	79.0	53.8	66.0
1.786000	20.5	8.3	9.000	L1	9.7	52.5	73.0	51.7	60.0
6.766000	30.2	25.0	9.000	L1	9.9	42.8	73.0	35.0	60.0
16.830000	23.2	17.0	9.000	L1	10.1	49.8	73.0	43.0	60.0

EUT Configuration: EUT 1 (AC Mains port #1)

NEUTRAL LINE

Operating mode: F(Copy)

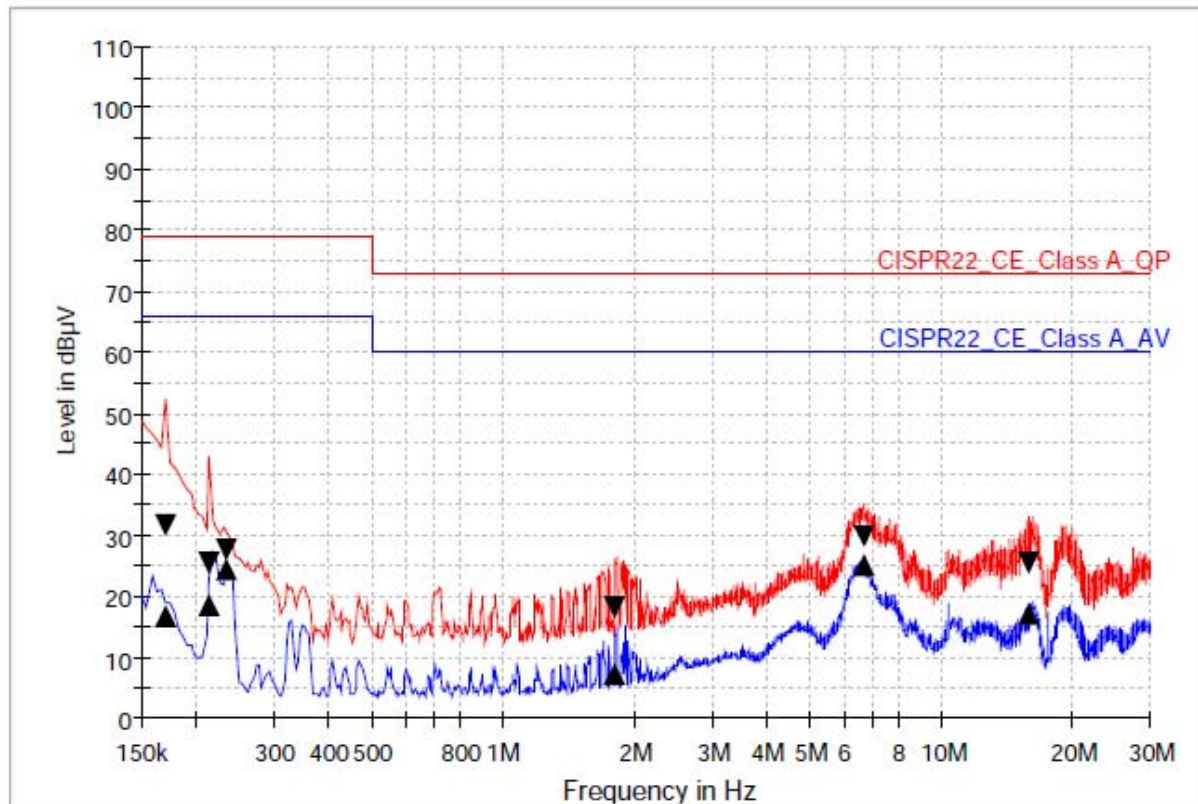

### Limit and Margin1

Frequency (MHz)	QuasiPeak (dBµV)	CAverage (dBµV)	Bandwidth (kHz)	Line	Corr. (dB)	Margin - QPK (dB)	Limit - QPK (dBµV)	Margin - CAV (dB)	Limit - CAV (dBµV)
0.170000	31.6	16.9	9.000	N	9.7	47.4	79.0	49.1	66.0
0.214000	25.4	18.6	9.000	N	9.7	53.6	79.0	47.4	66.0
0.234000	27.8	24.3	9.000	N	9.7	51.2	79.0	41.7	66.0
1.802000	18.3	7.1	9.000	N	9.7	54.7	73.0	52.9	60.0
6.690000	29.8	25.0	9.000	N	9.9	43.2	73.0	35.0	60.0
15.930000	25.6	17.3	9.000	N	10.1	47.4	73.0	42.7	60.0

EUT Configuration: EUT 1 (AC Mains port #1)

HOT LINE

Operating mode: H(WiFi Scan (2.4 G))

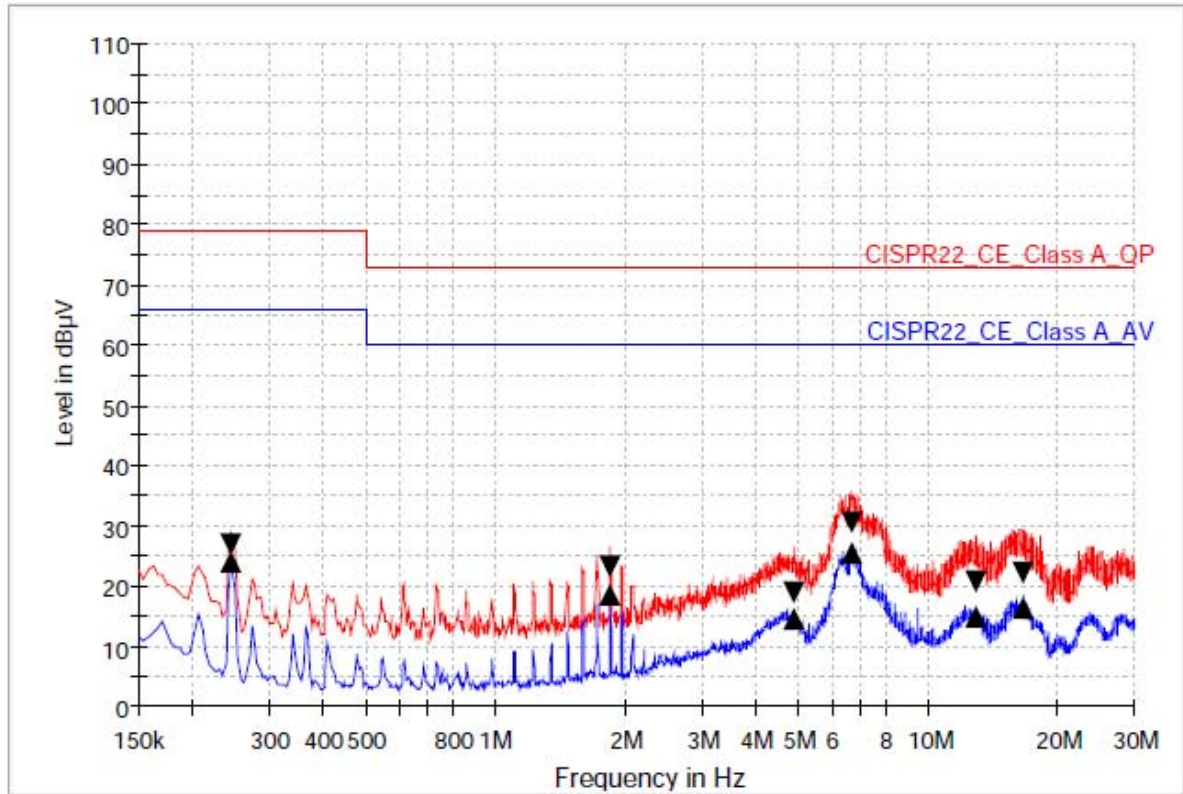

### Limit and Margin1

Frequency (MHz)	QuasiPeak (dBµV)	CAverage (dBµV)	Bandwidth (kHz)	Line	Corr. (dB)	Margin - QPK (dB)	Limit - QPK (dBµV)	Margin - CAV (dB)	Limit - CAV (dBµV)
0.246000	26.9	24.0	9.000	L1	9.7	52.1	79.0	42.0	66.0
1.846000	23.1	18.7	9.000	L1	9.7	49.9	73.0	41.3	60.0
4.914000	18.8	14.6	9.000	L1	9.8	54.2	73.0	45.4	60.0
6.686000	30.5	25.6	9.000	L1	9.9	42.5	73.0	34.4	60.0
12.982000	20.7	14.9	9.000	L1	10.1	52.4	73.0	45.1	60.0
16.534000	22.4	16.4	9.000	L1	10.1	50.6	73.0	43.6	60.0

EUT Configuration: EUT 1 (AC Mains port #1)

NEUTRAL LINE

Operating mode: H(WiFi Scan (2.4 G))

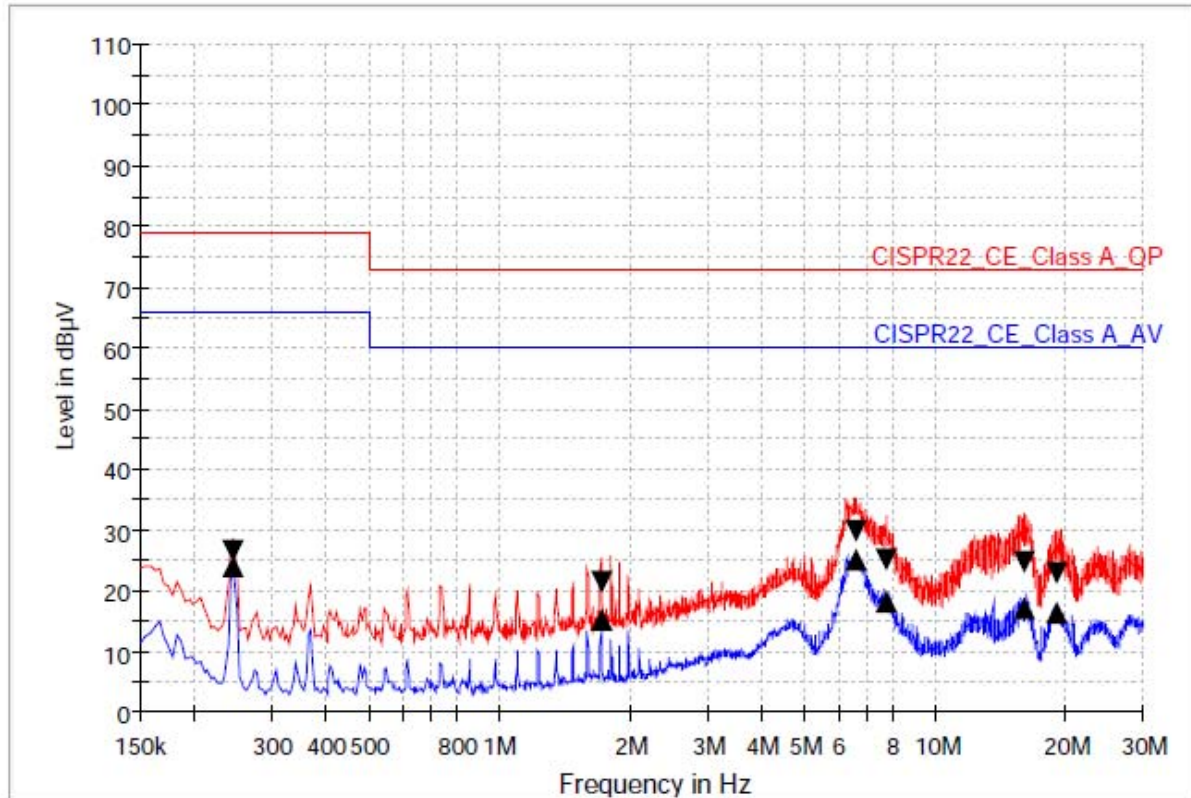

### Limit and Margin1

Frequency (MHz)	QuasiPeak (dBµV)	CAverage (dBµV)	Bandwidth (kHz)	Line	Corr. (dB)	Margin - QPK (dB)	Limit - QPK (dBµV)	Margin - CAV (dB)	Limit - CAV (dBµV)
0.246000	26.8	23.9	9.000	N	9.7	52.2	79.0	42.1	66.0
1.714000	21.3	15.4	9.000	N	9.7	51.7	73.0	44.6	60.0
6.558000	30.0	25.0	9.000	N	9.9	43.0	73.0	35.0	60.0
7.750000	25.2	18.1	9.000	N	10.0	47.8	73.0	41.9	60.0
16.070000	24.8	17.2	9.000	N	10.1	48.2	73.0	42.8	60.0
18.918000	22.9	16.4	9.000	N	10.2	50.1	73.0	43.6	60.0

EUT Configuration: EUT 1 (AC Mains port #1)

HOT LINE

Operating mode: J(USB Memory Stick Scan)

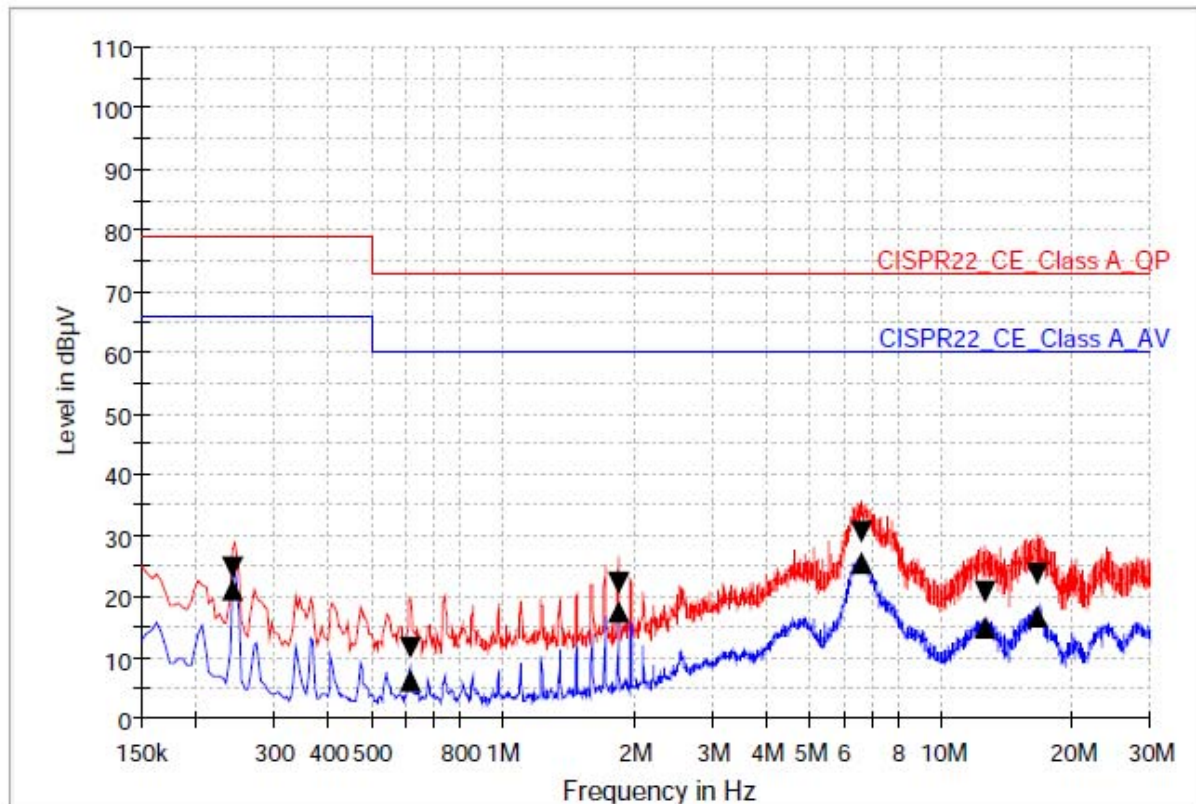

### Limit and Margin1

Frequency (MHz)	QuasiPeak (dBµV)	CAverage (dBµV)	Bandwidth (kHz)	Line	Corr. (dB)	Margin - QPK (dB)	Limit - QPK (dBµV)	Margin - CAV (dB)	Limit - CAV (dBµV)
0.242000	24.6	21.1	9.000	L1	9.7	54.4	79.0	44.9	66.0
0.618000	11.6	6.2	9.000	L1	9.7	61.4	73.0	53.8	60.0
1.842000	22.3	17.5	9.000	L1	9.7	50.7	73.0	42.5	60.0
6.570000	30.5	25.4	9.000	L1	9.9	42.5	73.0	34.6	60.0
12.650000	20.9	15.0	9.000	L1	10.1	52.1	73.0	45.0	60.0
16.542000	23.5	16.9	9.000	L1	10.1	49.5	73.0	43.1	60.0



EUT Configuration: EUT 1 (AC Mains port #1)

NEUTRAL LINE

Operating mode: J(USB Memory Stick Scan)

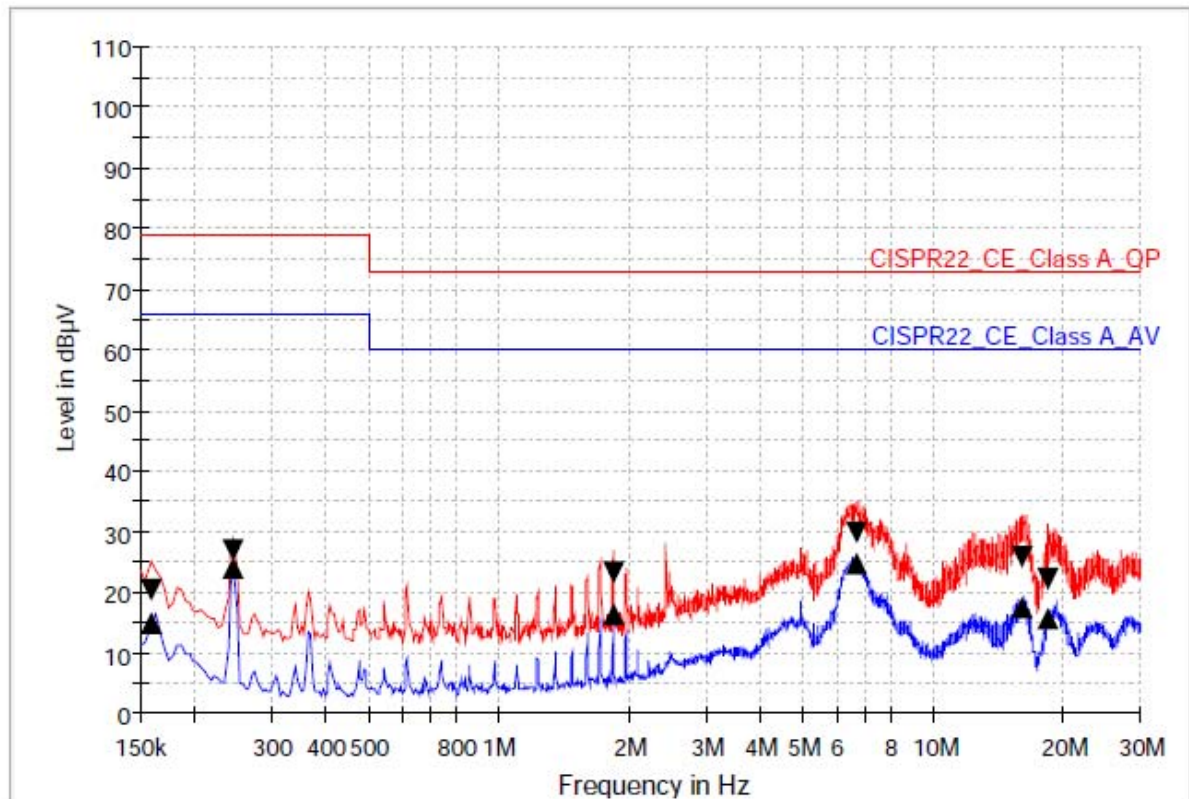

### Limit and Margin1

Frequency (MHz)	QuasiPeak (dBµV)	CAverage (dBµV)	Bandwidth (kHz)	Line	Corr. (dB)	Margin - QPK (dB)	Limit - QPK (dBµV)	Margin - CAV (dB)	Limit - CAV (dBµV)
0.158000	20.3	14.9	9.000	N	9.7	58.7	79.0	51.1	66.0
0.246000	26.8	24.0	9.000	N	9.7	52.2	79.0	42.0	66.0
1.838000	23.2	16.6	9.000	N	9.7	49.8	73.0	43.4	60.0
6.630000	30.0	24.9	9.000	N	9.9	43.0	73.0	35.1	60.0
15.962000	26.0	17.6	9.000	N	10.1	47.0	73.0	42.4	60.0
18.474000	22.2	15.7	9.000	N	10.2	50.8	73.0	44.3	60.0

EUT Configuration: EUT 1 (AC Mains port #1)

HOT LINE

Operating mode: K(Fax Tx)

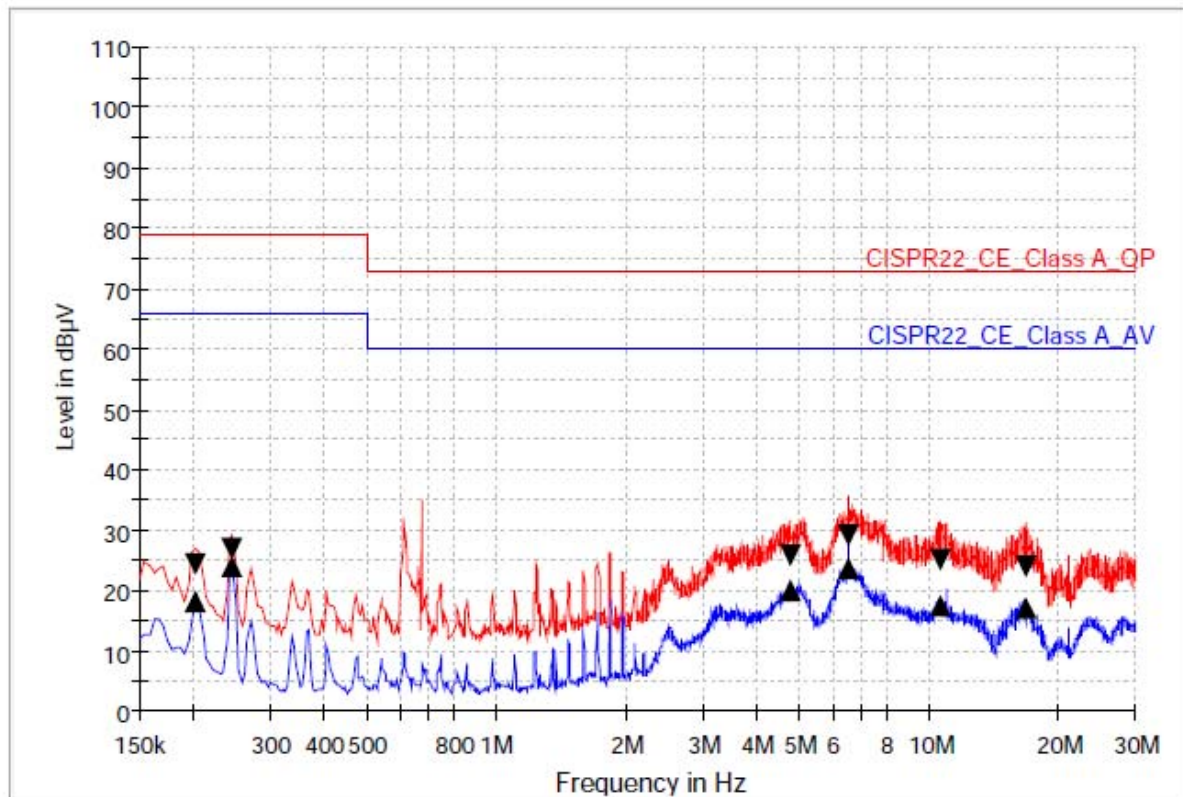

### Limit and Margin1

Frequency (MHz)	QuasiPeak (dBµV)	CAverage (dBµV)	Bandwidth (kHz)	Line	Corr. (dB)	Margin - QPK (dB)	Limit - QPK (dBµV)	Margin - CAV (dB)	Limit - CAV (dBµV)
0.202000	24.3	18.1	9.000	L1	9.7	54.7	79.0	47.9	66.0
0.246000	26.9	24.2	9.000	L1	9.7	52.1	79.0	41.8	66.0
4.814000	25.8	20.2	9.000	L1	9.8	47.2	73.0	39.8	60.0
6.522000	29.0	23.6	9.000	L1	9.9	44.0	73.0	36.4	60.0
10.622000	25.0	17.5	9.000	L1	10.1	48.0	73.0	42.5	60.0
16.694000	24.0	17.2	9.000	L1	10.1	49.0	73.0	42.8	60.0

EUT Configuration: EUT 1 (AC Mains port #1)

NEUTRAL LINE

Operating mode: K(Fax Tx)

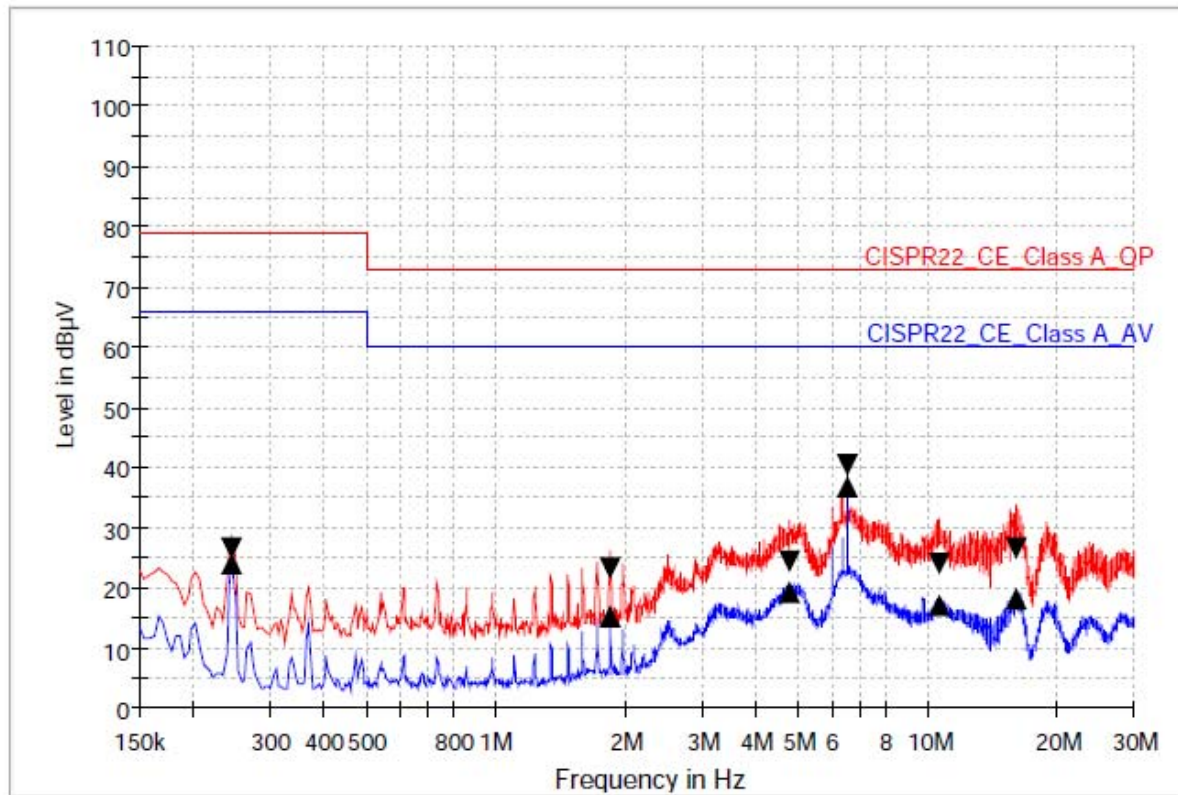

### Limit and Margin1

Frequency (MHz)	QuasiPeak (dBµV)	CAverage (dBµV)	Bandwidth (kHz)	Line	Corr. (dB)	Margin - QPK (dB)	Limit - QPK (dBµV)	Margin - CAV (dB)	Limit - CAV (dBµV)
0.246000	26.8	24.0	9.000	N	9.7	52.2	79.0	42.0	66.0
1.838000	23.4	15.4	9.000	N	9.7	49.6	73.0	44.6	60.0
4.786000	24.2	19.2	9.000	N	9.8	48.8	73.0	40.8	60.0
6.522000	40.6	36.7	9.000	N	9.9	32.4	73.0	23.3	60.0
10.578000	24.1	17.1	9.000	N	10.1	48.9	73.0	42.9	60.0
15.998000	26.5	18.3	9.000	N	10.1	46.5	73.0	41.7	60.0

EUT Configuration: EUT 1 (AC Mains port #1)

HOT LINE

Operating mode: L(Fax Rx)

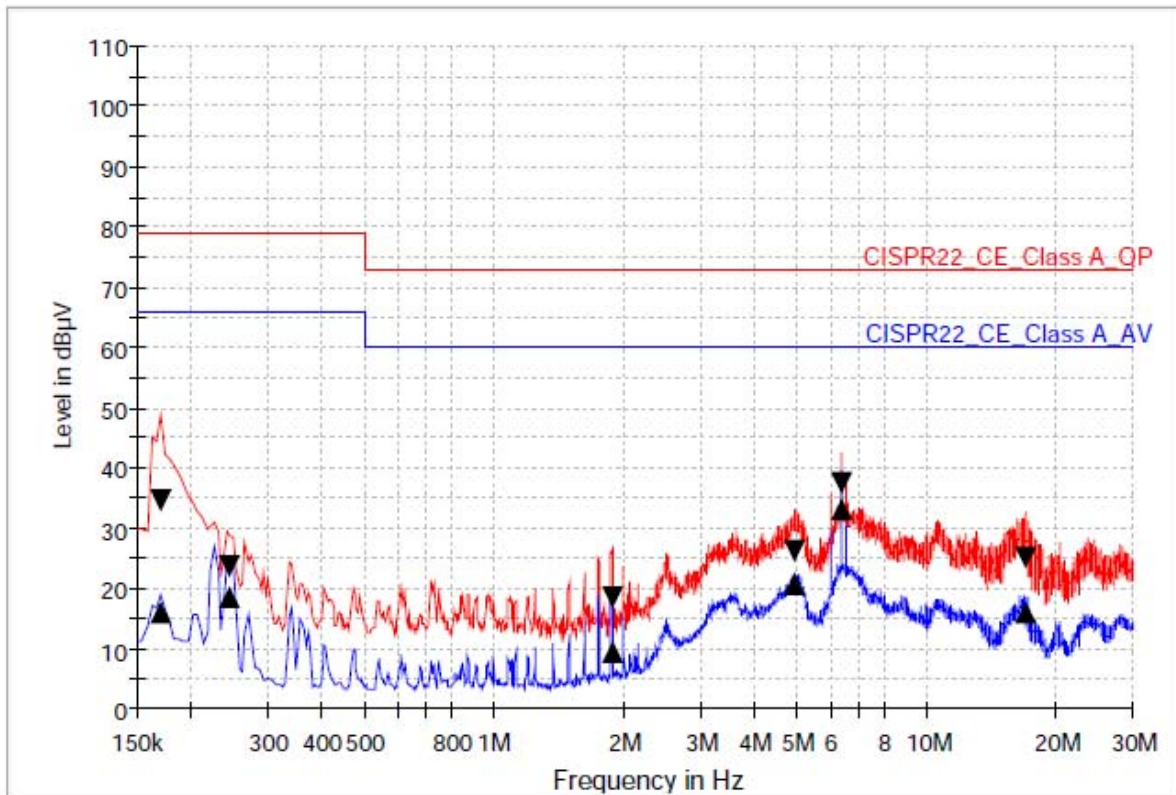

### Limit and Margin1

Frequency (MHz)	QuasiPeak (dBµV)	CAverage (dBµV)	Bandwidth (kHz)	Line	Corr. (dB)	Margin - QPK (dB)	Limit - QPK (dBµV)	Margin - CAV (dB)	Limit - CAV (dBµV)
0.170000	34.5	15.8	9.000	L1	9.7	44.5	79.0	50.2	66.0
0.246000	23.7	18.6	9.000	L1	9.7	55.3	79.0	47.4	66.0
1.874000	18.4	9.5	9.000	L1	9.7	54.6	73.0	50.5	60.0
4.938000	26.1	20.8	9.000	L1	9.8	46.9	73.0	39.2	60.0
6.350000	37.5	33.3	9.000	L1	9.9	35.5	73.0	26.7	60.0
17.018000	25.2	15.9	9.000	L1	10.1	47.8	73.0	44.1	60.0

EUT Configuration: EUT 1 (AC Mains port #1)

NEUTRAL LINE

Operating mode: L(Fax Rx)

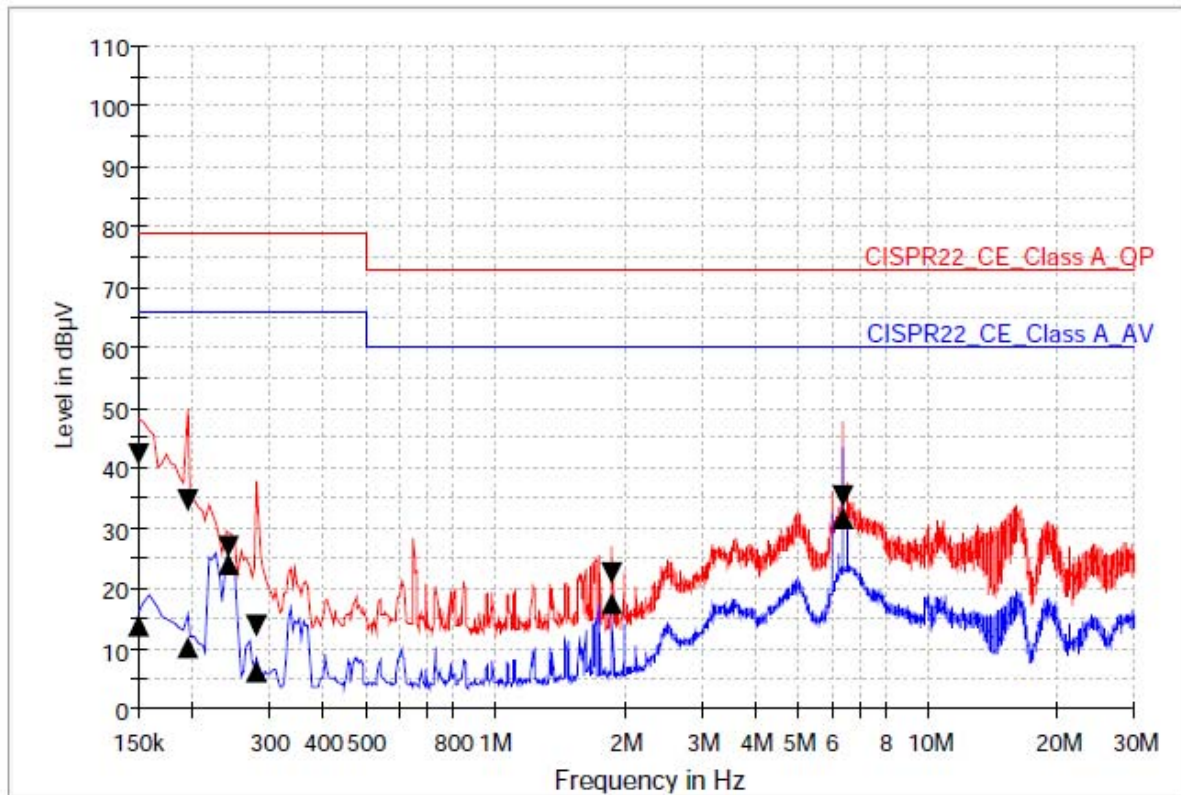

### Limit and Margin1

Frequency (MHz)	QuasiPeak (dBµV)	CAverage (dBµV)	Bandwidth (kHz)	Line	Corr. (dB)	Margin - QPK (dB)	Limit - QPK (dBµV)	Margin - CAV (dB)	Limit - CAV (dBµV)
0.150000	42.1	13.9	9.000	N	9.7	36.9	79.0	52.1	66.0
0.194000	34.6	10.1	9.000	N	9.7	44.4	79.0	55.9	66.0
0.242000	27.1	24.2	9.000	N	9.7	51.9	79.0	41.8	66.0
0.282000	13.8	6.3	9.000	N	9.7	65.2	79.0	59.7	66.0
1.866000	22.8	17.5	9.000	N	9.7	50.2	73.0	42.5	60.0
6.350000	35.2	31.7	9.000	N	9.9	37.8	73.0	28.3	60.0

EUT Configuration: **EUT 2** (AC Mains port #1)

**HOT LINE**

Operating mode: C(WiFi Print (2.4 G))

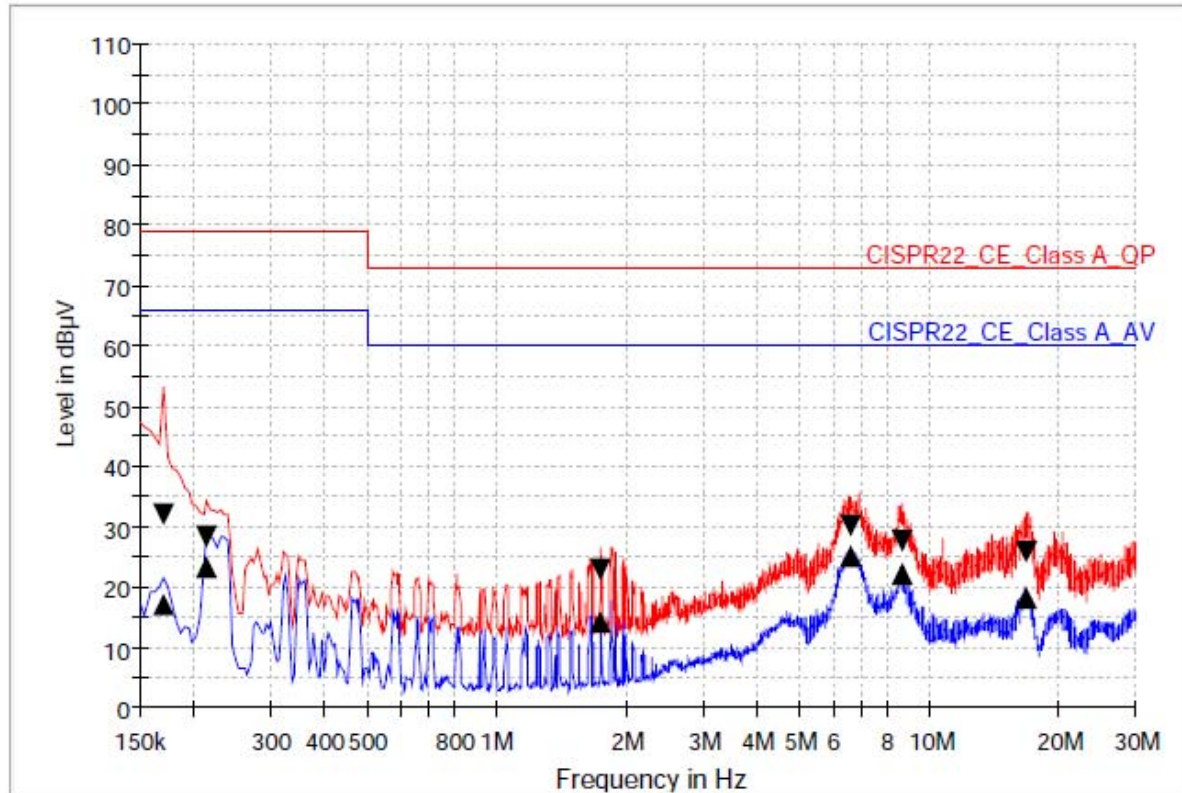

### Limit and Margin1

Frequency (MHz)	QuasiPeak (dBµV)	CAverage (dBµV)	Bandwidth (kHz)	Line	Corr. (dB)	Margin - QPK (dB)	Limit - QPK (dBµV)	Margin - CAV (dB)	Limit - CAV (dBµV)
0.170000	32.0	17.1	9.000	L1	9.7	47.0	79.0	48.9	66.0
0.214000	28.4	23.3	9.000	L1	9.7	50.6	79.0	42.7	66.0
1.738000	22.8	14.1	9.000	L1	9.7	50.2	73.0	45.9	60.0
6.594000	30.3	25.2	9.000	L1	9.9	42.7	73.0	34.8	60.0
8.630000	27.8	22.2	9.000	L1	10.0	45.2	73.0	37.8	60.0
16.702000	26.0	18.1	9.000	L1	10.1	47.0	73.0	41.9	60.0

EUT Configuration: **EUT 2 (AC Mains port #1)**

**NEUTRAL LINE**

Operating mode: C(WiFi Print (2.4 G))

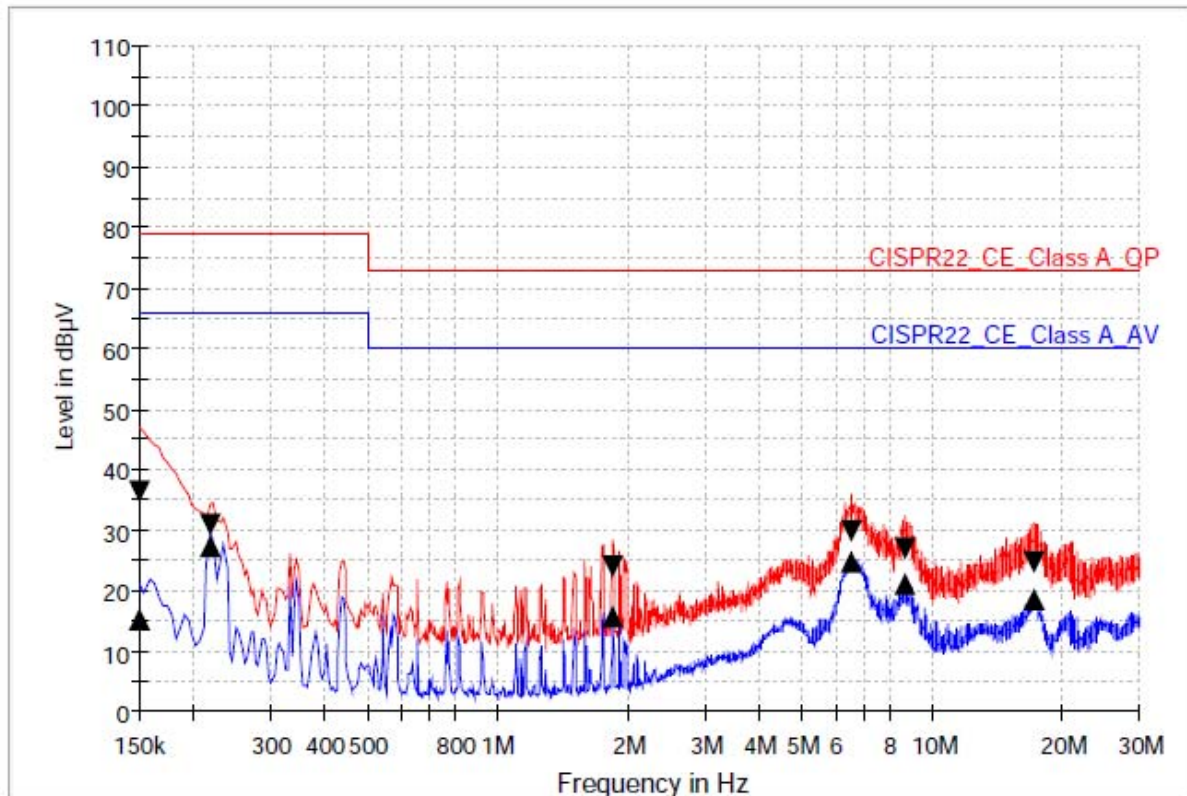

### Limit and Margin1

Frequency (MHz)	QuasiPeak (dBµV)	CAverage (dBµV)	Bandwidth (kHz)	Line	Corr. (dB)	Margin - QPK (dB)	Limit - QPK (dBµV)	Margin - CAV (dB)	Limit - CAV (dBµV)
0.150000	36.6	15.3	9.000	N	9.7	42.4	79.0	50.7	66.0
0.218000	31.0	27.1	9.000	N	9.7	48.0	79.0	38.9	66.0
1.834000	24.1	15.6	9.000	N	9.7	48.9	73.0	44.4	60.0
6.522000	29.9	24.8	9.000	N	9.9	43.1	73.0	35.2	60.0
8.682000	27.1	21.2	9.000	N	10.0	45.9	73.0	38.8	60.0
17.242000	24.8	18.4	9.000	N	10.1	48.2	73.0	41.6	60.0

EUT Configuration: **EUT 2 (AC Mains port #1)**

**HOT LINE**

Operating mode: G(LAN Scan)

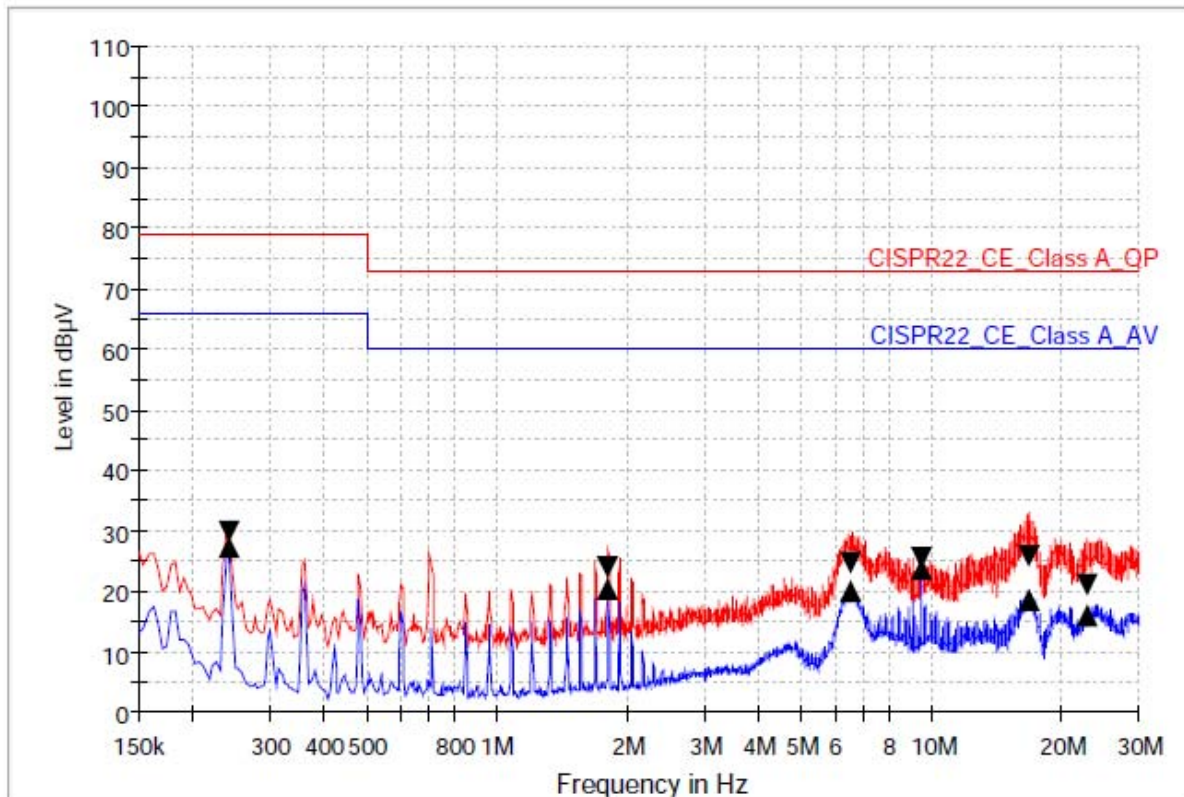

### Limit and Margin1

Frequency (MHz)	QuasiPeak (dBµV)	CAverage (dBµV)	Bandwidth (kHz)	Line	Corr. (dB)	Margin - QPK (dB)	Limit - QPK (dBµV)	Margin - CAV (dB)	Limit - CAV (dBµV)
0.242000	29.8	27.4	9.000	L1	9.7	49.2	79.0	38.6	66.0
1.802000	24.1	20.3	9.000	L1	9.7	48.9	73.0	39.7	60.0
6.542000	24.6	19.9	9.000	L1	9.9	48.4	73.0	40.1	60.0
9.446000	25.4	23.8	9.000	L1	10.0	47.6	73.0	36.2	60.0
16.802000	25.7	18.5	9.000	L1	10.1	47.3	73.0	41.5	60.0
22.870000	21.2	15.8	9.000	L1	10.2	51.8	73.0	44.2	60.0



EUT Configuration: **EUT 2 (AC Mains port #1)**

**NEUTRAL LINE**

Operating mode: G(LAN Scan)

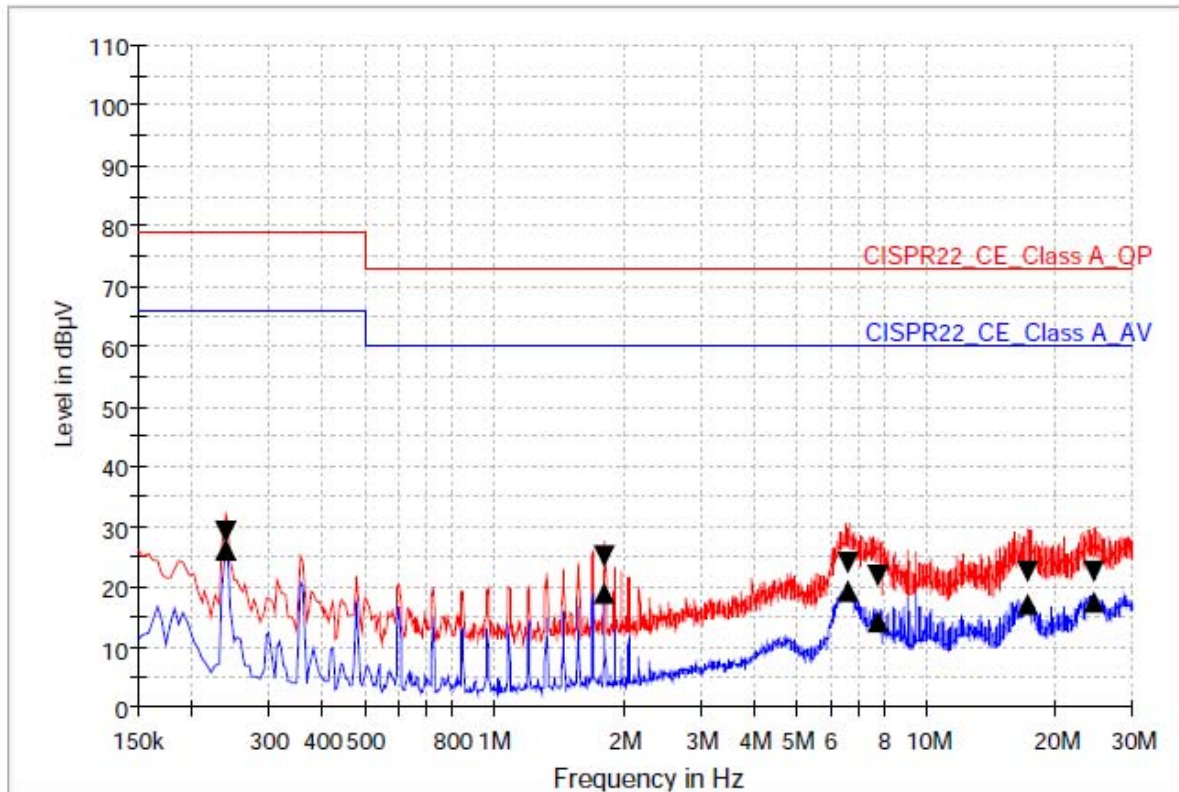

### Limit and Margin1

Frequency (MHz)	QuasiPeak (dBµV)	CAverage (dBµV)	Bandwidth (kHz)	Line	Corr. (dB)	Margin - QPK (dB)	Limit - QPK (dBµV)	Margin - CAV (dB)	Limit - CAV (dBµV)
0.238000	29.1	26.4	9.000	N	9.7	49.9	79.0	39.6	66.0
1.798000	25.2	19.0	9.000	N	9.7	47.8	73.0	41.0	60.0
6.582000	23.9	19.2	9.000	N	9.9	49.1	73.0	40.8	60.0
7.734000	21.8	14.1	9.000	N	10.0	51.2	73.0	45.9	60.0
17.130000	22.7	17.0	9.000	N	10.1	50.3	73.0	43.0	60.0
24.470000	22.7	17.7	9.000	N	10.3	50.3	73.0	42.3	60.0

EUT Configuration: **EUT 3 (AC Mains port #1)**

**HOT LINE**

Operating mode: E(USB Memory Stick Print)

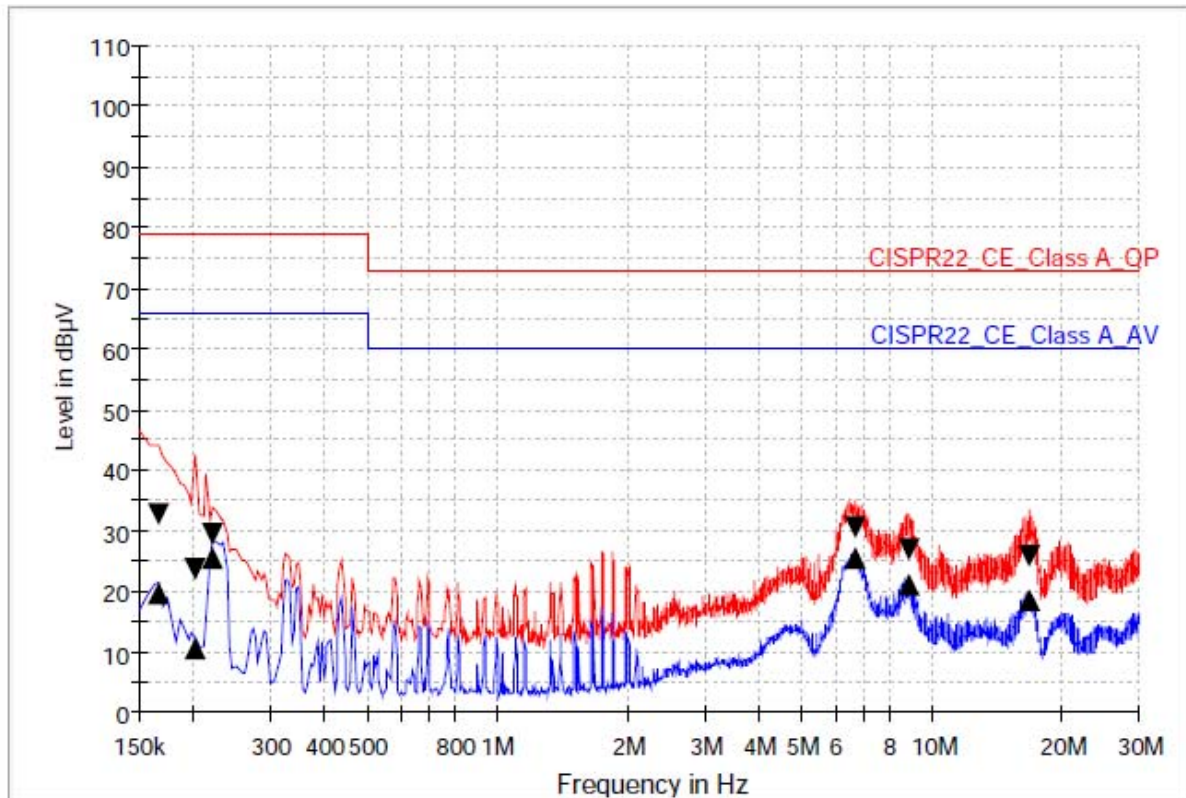

### Limit and Margin1

Frequency (MHz)	QuasiPeak (dBµV)	CAverage (dBµV)	Bandwidth (kHz)	Line	Corr. (dB)	Margin - QPK (dB)	Limit - QPK (dBµV)	Margin - CAV (dB)	Limit - CAV (dBµV)
0.166000	32.6	19.7	9.000	L1	9.7	46.4	79.0	46.3	66.0
0.202000	23.8	10.6	9.000	L1	9.7	55.2	79.0	55.4	66.0
0.222000	29.4	25.6	9.000	L1	9.7	49.6	79.0	40.4	66.0
6.642000	30.4	25.4	9.000	L1	9.9	42.6	73.0	34.6	60.0
8.910000	26.9	21.3	9.000	L1	10.0	46.1	73.0	38.7	60.0
16.710000	26.0	18.5	9.000	L1	10.1	47.0	73.0	41.5	60.0

EUT Configuration: **EUT 3 (AC Mains port #1)**

**NEUTRAL LINE**

Operating mode: E(USB Memory Stick Print)

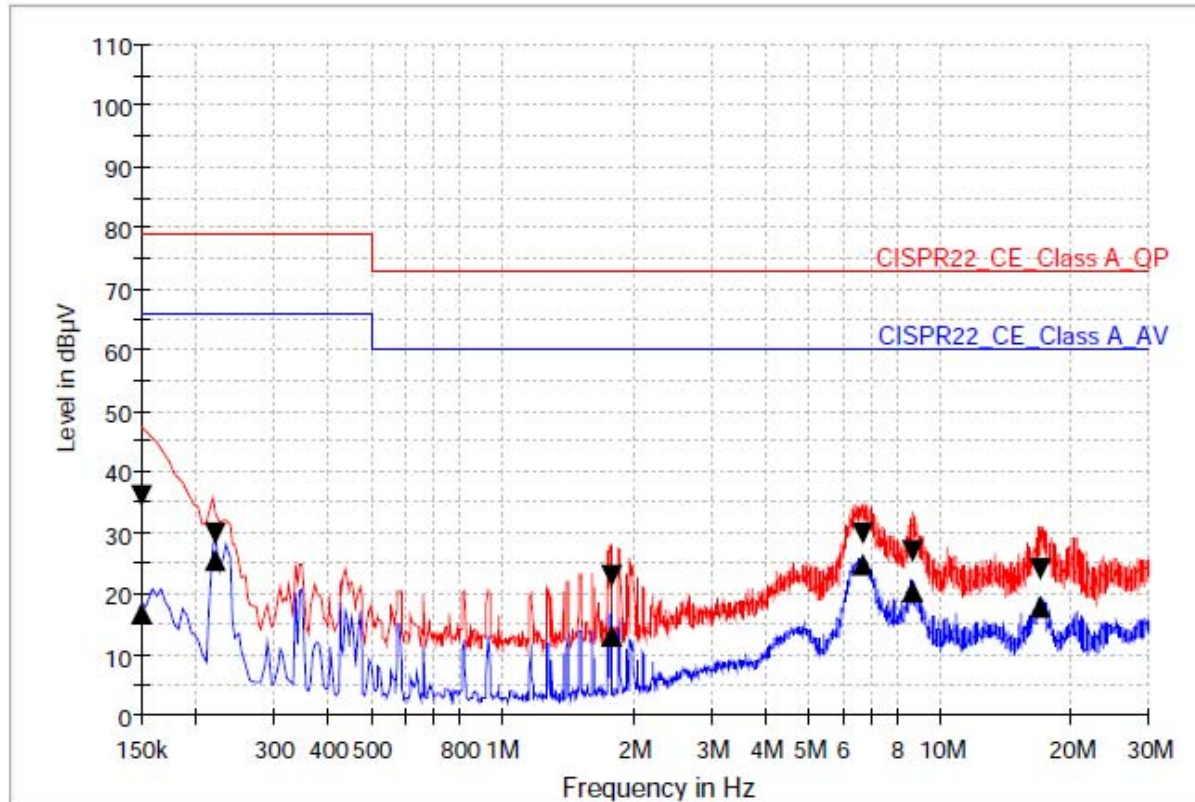

### Limit and Margin1

Frequency (MHz)	QuasiPeak (dBµV)	CAverage (dBµV)	Bandwidth (kHz)	Line	Corr. (dB)	Margin - QPK (dB)	Limit - QPK (dBµV)	Margin - CAV (dB)	Limit - CAV (dBµV)
0.150000	36.1	16.8	9.000	N	9.7	42.9	79.0	49.2	66.0
0.222000	29.7	25.6	9.000	N	9.7	49.3	79.0	40.4	66.0
1.774000	22.9	13.0	9.000	N	9.7	50.1	73.0	47.0	60.0
6.670000	29.9	24.9	9.000	N	9.9	43.1	73.0	35.1	60.0
8.622000	27.0	20.3	9.000	N	10.0	46.0	73.0	39.7	60.0
16.926000	24.1	18.0	9.000	N	10.1	48.9	73.0	42.0	60.0

EUT Configuration: **EUT 3** (AC Mains port #1)

HOT LINE

Operating mode: I(WiFi Scan (5 G))

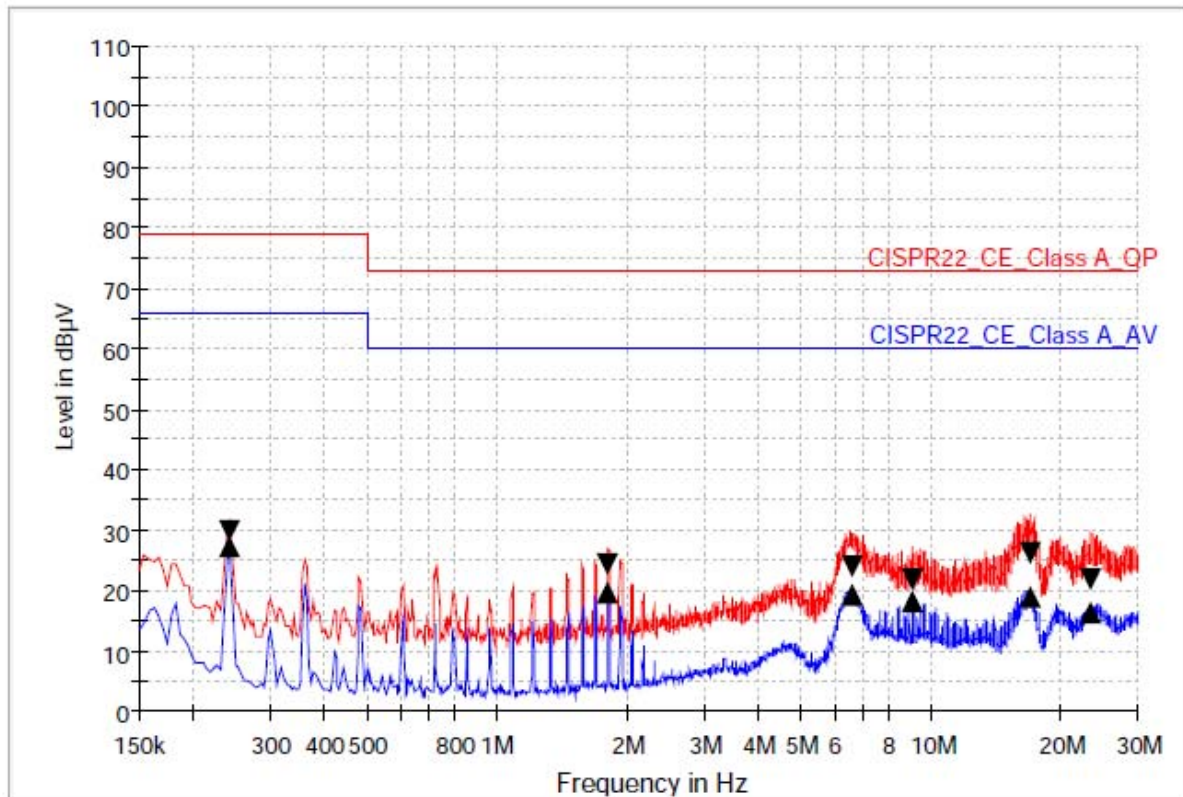

### Limit and Margin1

Frequency (MHz)	QuasiPeak (dBµV)	CAverage (dBµV)	Bandwidth (kHz)	Line	Corr. (dB)	Margin - QPK (dB)	Limit - QPK (dBµV)	Margin - CAV (dB)	Limit - CAV (dBµV)
0.242000	29.8	27.5	9.000	L1	9.7	49.2	79.0	38.5	66.0
1.806000	24.4	19.6	9.000	L1	9.7	48.6	73.0	40.4	60.0
6.614000	24.2	19.4	9.000	L1	9.9	48.8	73.0	40.6	60.0
9.050000	22.0	18.3	9.000	L1	10.0	51.0	73.0	41.7	60.0
16.990000	26.2	19.1	9.000	L1	10.1	46.8	73.0	40.9	60.0
23.406000	21.8	16.5	9.000	L1	10.3	51.2	73.0	43.5	60.0

EUT Configuration: **EUT 3** (AC Mains port #1)

NEUTRAL LINE

Operating mode: I(WiFi Scan (5 G))

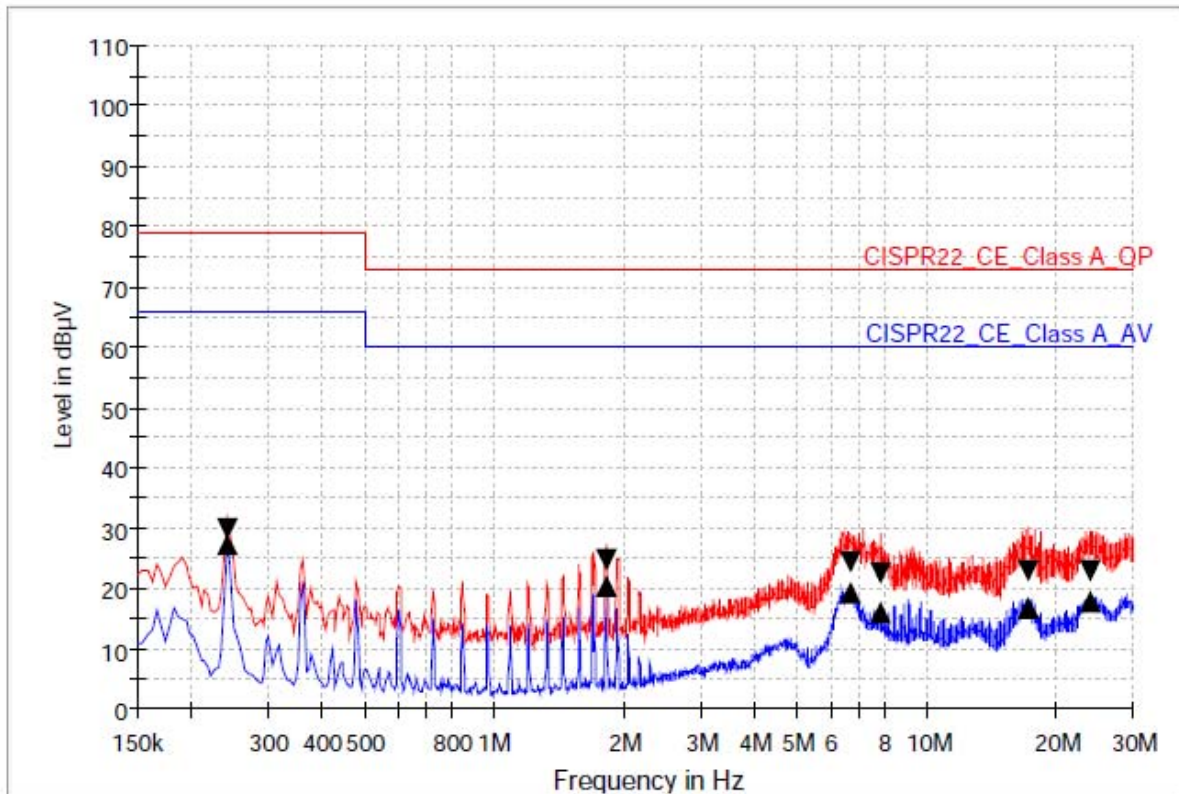

### Limit and Margin1

Frequency (MHz)	QuasiPeak (dBµV)	CAverage (dBµV)	Bandwidth (kHz)	Line	Corr. (dB)	Margin - QPK (dB)	Limit - QPK (dBµV)	Margin - CAV (dB)	Limit - CAV (dBµV)
0.242000	29.7	27.5	9.000	N	9.7	49.3	79.0	38.5	66.0
1.814000	24.7	20.3	9.000	N	9.7	48.3	73.0	39.7	60.0
6.646000	24.3	19.4	9.000	N	9.9	48.7	73.0	40.6	60.0
7.794000	22.6	16.1	9.000	N	10.0	50.4	73.0	43.9	60.0
17.210000	23.1	16.8	9.000	N	10.1	49.9	73.0	43.2	60.0
23.838000	23.1	18.0	9.000	N	10.3	49.9	73.0	42.0	60.0

## 5.2 Radiated Emission

### 5.2.1 Test setup

The radiated emissions measurements were in the 3/10 m, Semi Anechoic Chamber. The EUT and all local supporting equipments were placed on a non-conductive table approximately 0.8 m above the ground plane.

The frequency spectrum from 30 MHz to the maximum frequency as specified in CFR 47 Part 15 section 15.33 was scanned and emission levels maximized at each frequency recorded. The system was rotated 360°, and the antenna was varied in height between 1.0 m and 4.0 m in order to determine the maximum emission levels.

This procedure was performed for both horizontal and vertical polarization of the receiving antenna.

Preliminary radiated emission test was conducted using the procedure in ANSI C63.4: 2014 8.3.1.1 below 1 000 MHz, 8.3.1.2 above 1 GHz to determine the worse operating conditions

Measurement distance between the EUT and an antenna was as below table.

Frequency range (MHz)	Measurement Distance	
	Class B Device	Class A Device
Below 1 000 MHz	3 m	10 m
Above 1 000 MHz	3 m	3 m

The test set-up photos are included in appendix II.

Used Software for measurement is manufactured by TSJ and Rohde & Schwarz..

### 5.2.2 Measurement frequency range

Highest frequency generated or used in the device or on which the device operates or tunes	Upper Frequency of Measurement range (MHz)
Below 1.705 MHz	30
(1.705 ~ 108) MHz	1 000
(108 ~ 500) MHz	2 000
(500 ~ 1 000) MHz	5 000
Above 1 000 MHz	5th harmonic of the highest freq. or 40 GHz, whichever is lower

The measurement uncertainties are given with 95 % confidence.

### 5.2.3 Measurement uncertainty

Frequency range	Uncertainty
Below 1 000 MHz	4.40 dB
Above 1 000 MHz	4.09 dB

The measurement uncertainties are given with 95 % confidence.

### 5.2.4 Test result

Date of Test	2020-06-05 ~ 07-01			
Temperature	(22.2 ± 2.4) °C	Relative humidity	(49.25 ± 3.05) % R.H.	
Operating Input Voltage	120 Vac	Input Frequency	60 Hz	
Frequency range	RBW	VBW	Detector Mode	Measurement distance
Below 1 000 MHz	120 kHz	300 kHz	Peak or Q.P.	10 m
Date of Test	2020-06-05 ~ 07-01			
Temperature	(22.6 ± 1.8) °C	Relative humidity	(49.85 ± 1.95) % R.H.	
Frequency range	RBW	VBW	Detector Mode	Measurement distance
Above 1 000 MHz	1 MHz	1 MHz or 10 Hz	Peak or Average	3 m
Test Mode	Mode A ~ L			
<b>Test Result</b>	<b>Pass</b>	Tested By	Chu, Woo-Sik	

### 5.2.5 Sample Calculated Example

At 80 MHz

Limit = 39.1 dB $\mu$ V/m

Result = Receiver reading value + Antenna Factor + Cable Loss - Pre-amplifier gain = 30 dB $\mu$ V/m

Margin = Limit - Result = 39.1 - 30 = 9.1

so the EUT has 9.1 dB margin at 80 MHz

### 5.2.6 Test Data

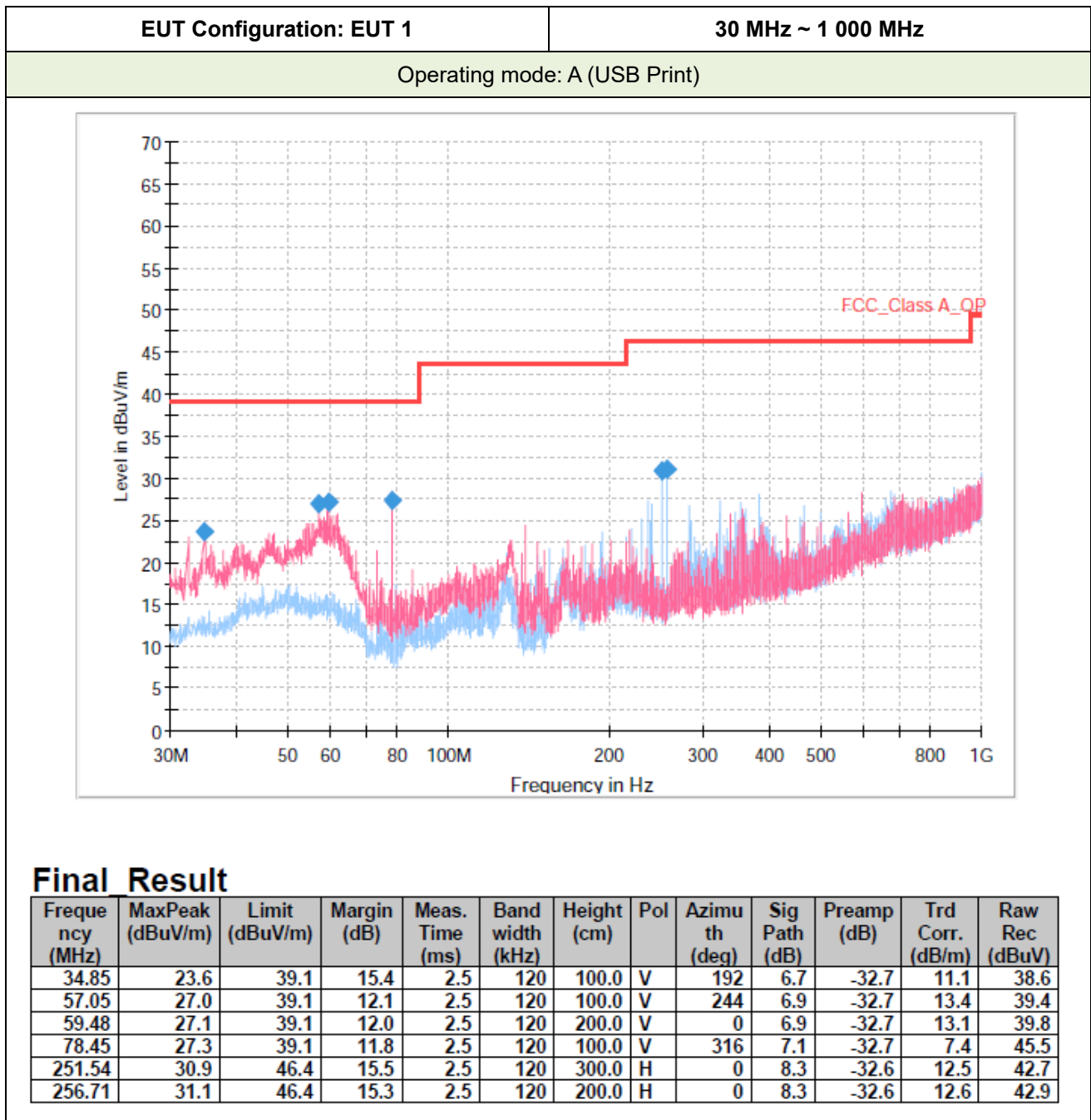

**NOTE** : Quasi Peaks are not measured because Peak Data meet Quasi-Peak limit.



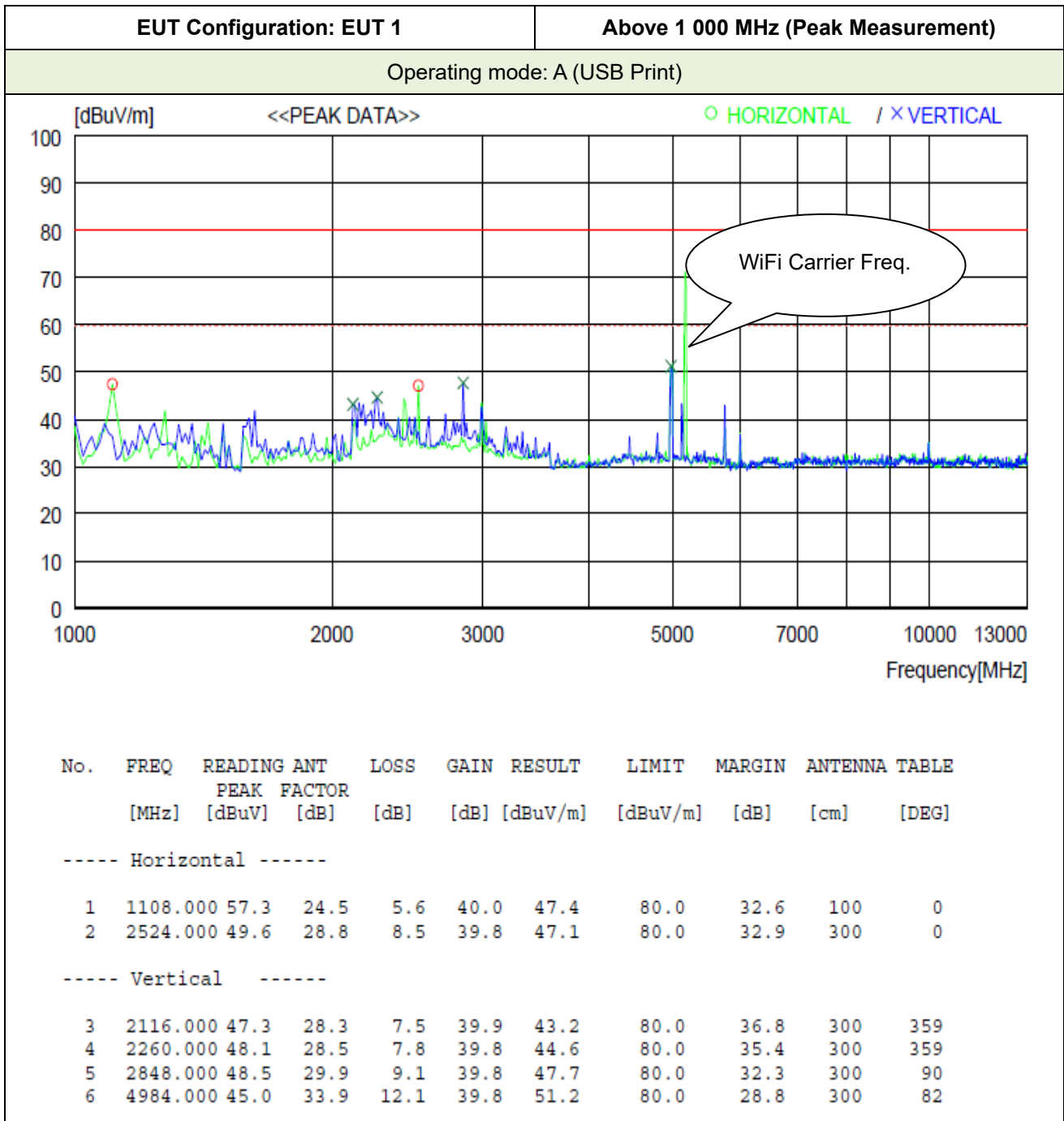

**NOTE:** Average mode was not measured, because Peak values were under the Average limit.

EUT Configuration: EUT 1

30 MHz ~ 1 000 MHz

Operating mode: B (LAN Print)

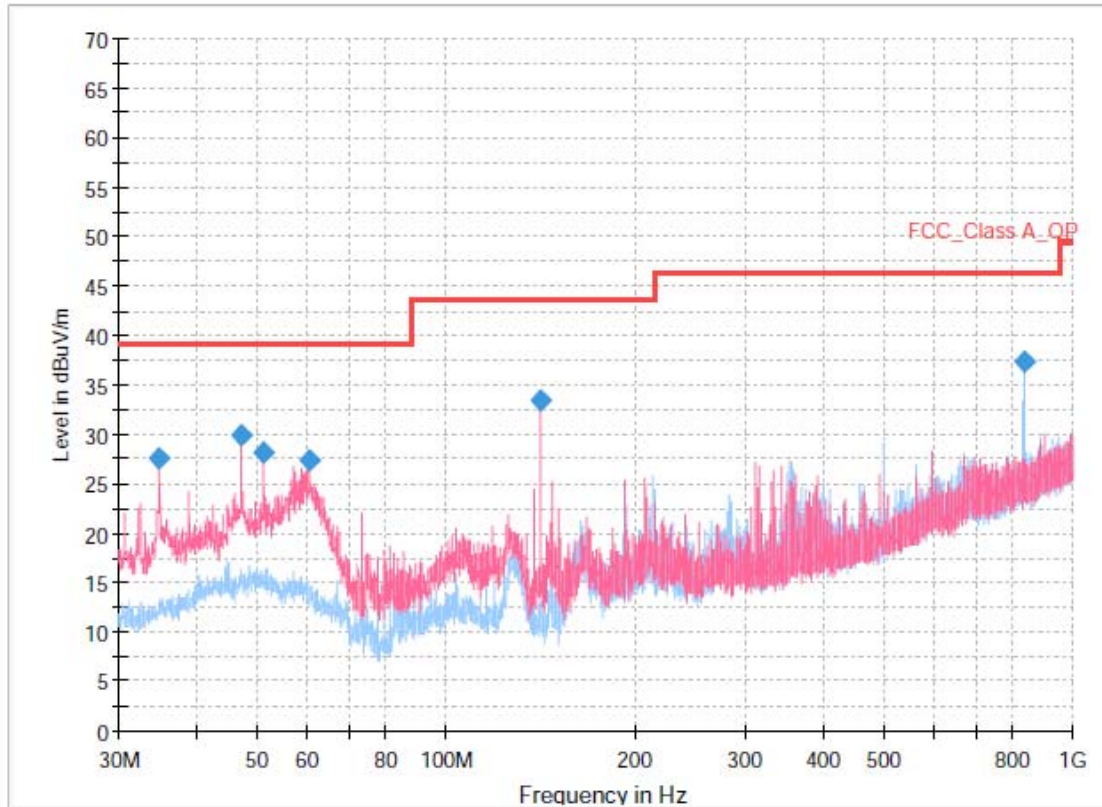

### Final Result

Frequency (MHz)	MaxPeak (dBuV/m)	Limit (dBuV/m)	Margin (dB)	Meas. Time (ms)	Band width (kHz)	Height (cm)	Pol	Azimuth (deg)	Sig Path (dB)	Preamp (dB)	Trd Corr. (dB/m)	Raw Rec (dBuV)
34.80	27.7	39.1	11.4	2.5	120	300.0	V	0	6.7	-32.7	11.1	42.6
47.08	30.0	39.1	9.1	2.5	120	300.0	V	0	6.8	-32.7	14.3	41.6
51.18	28.2	39.1	10.9	2.5	120	300.0	V	0	6.8	-32.7	14.3	39.8
60.50	27.4	39.1	11.7	2.5	120	100.0	V	34	6.9	-32.7	12.8	40.4
141.44	33.4	43.5	10.1	2.5	120	100.0	V	313	7.6	-32.6	7.9	50.6
835.42	37.4	46.4	9.0	2.5	120	100.0	H	142	10.7	-32.7	21.4	38.0

**NOTE** : Quasi Peaks are not measured because Peak Data meet Quasi-Peak limit.

EUT Configuration: EUT 1

Above 1 000 MHz (Peak Measurement)

Operating mode: B (LAN Print)

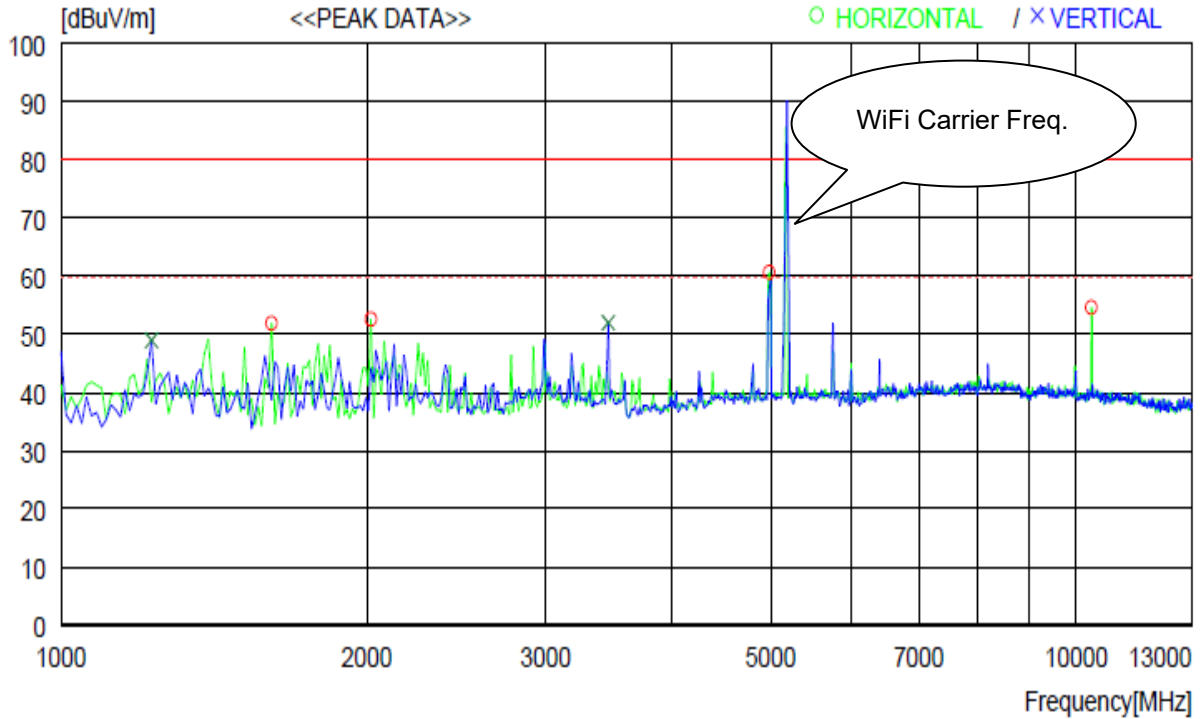

No.	FREQ [MHz]	READING [dBuV]	ANT PEAK FACTOR [dB]	LOSS [dB]	GAIN [dB]	RESULT [dBuV/m]	LIMIT [dBuV/m]	MARGIN [dB]	ANTENNA [cm]	TABLE [DEG]
----- Horizontal -----										
1	1612.000	59.0	26.1	6.7	39.9	51.9	80.0	28.1	300	104
2	2020.000	56.9	28.2	7.4	39.9	52.6	80.0	27.4	200	0
3	4984.000	54.5	33.9	12.1	39.8	60.7	80.0	19.3	200	0
4	10348.000	44.1	36.6	14.3	40.4	54.6	80.0	25.4	300	359
----- Vertical -----										
5	1228.000	58.3	24.8	5.9	40.0	49.0	80.0	31	200	0
6	3460.000	50.7	31.4	10.0	40.1	52.0	80.0	28	100	214

EUT Configuration: EUT 1

Above 1 000 MHz (Average Measurement )

Operating mode: B (LAN Print)

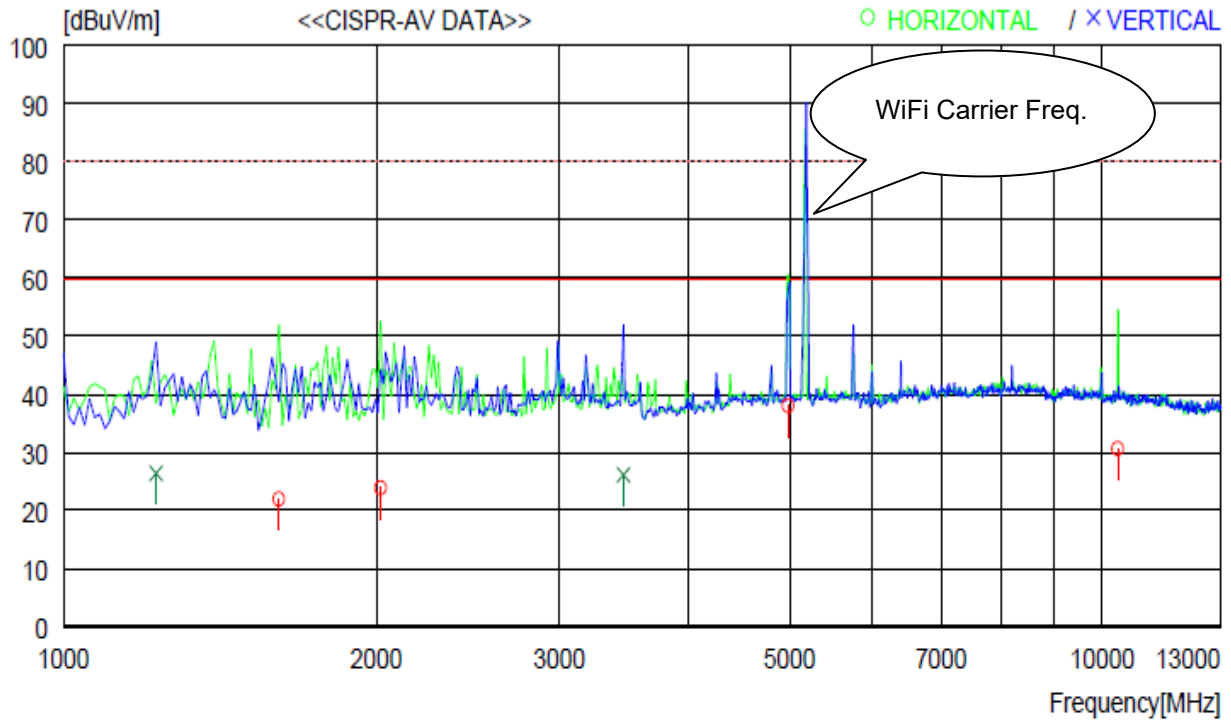

No.	FREQ [MHz]	READING [dBuV]	ANT CAV FACTOR [dB]	LOSS [dB]	GAIN [dB]	RESULT [dBuV/m]	LIMIT [dBuV/m]	MARGIN [dB]	ANTENNA [cm]	TABLE [DEG]
----- Horizontal -----										
1	1612.000	29.1	26.1	6.7	39.9	22.0	60.0	38.0	300	104
2	2020.000	28.2	28.2	7.4	39.9	23.9	60.0	36.1	200	0
3	4984.000	31.8	33.9	12.1	39.8	38.0	60.0	22.0	200	0
4	10348.000	20.1	36.6	14.3	40.4	30.6	60.0	29.4	300	359
----- Vertical -----										
5	1228.000	35.7	24.8	5.9	40.0	26.4	60.0	33.6	200	0
6	3460.000	24.8	31.4	10.0	40.1	26.1	60.0	33.9	100	214

EUT Configuration: EUT 1

30 MHz ~ 1 000 MHz

Operating mode: D(WiFi Print (5 G))

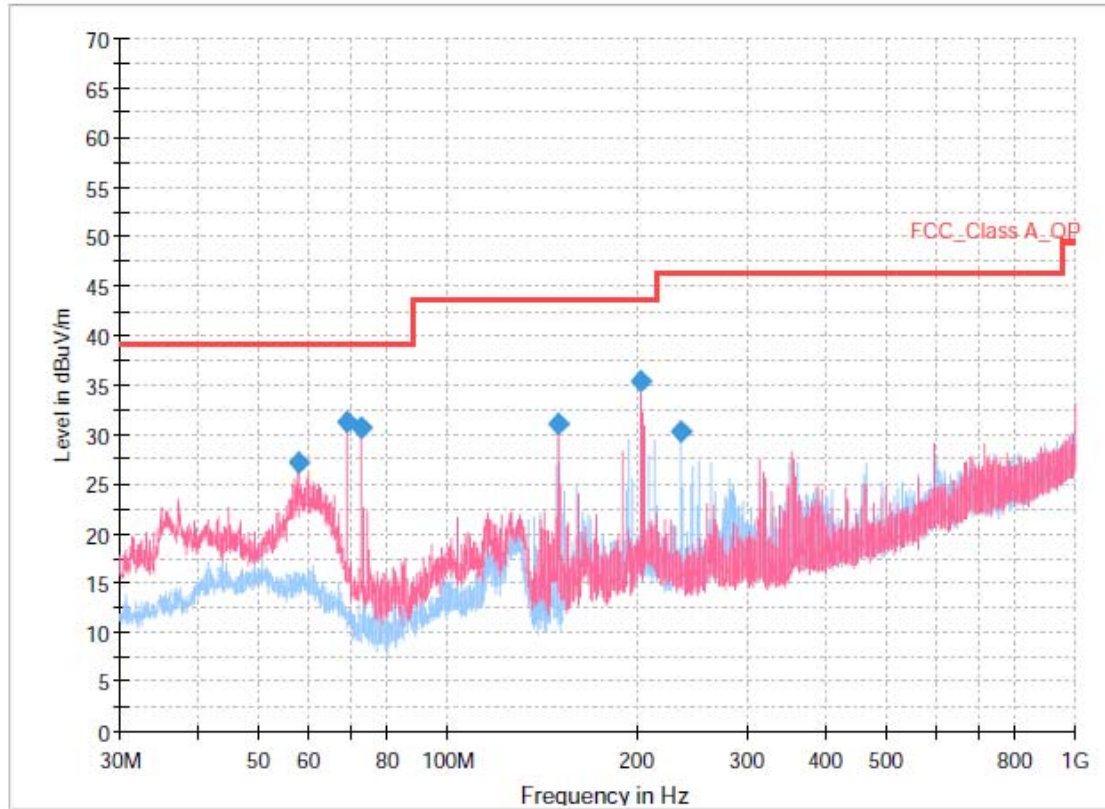

### Final Result

Frequency (MHz)	MaxPeak (dBuV/m)	Limit (dBuV/m)	Margin (dB)	Meas. Time (ms)	Band width (kHz)	Height (cm)	Pol	Azimuth (deg)	Sig Path (dB)	Preamp (dB)	Trd. Corr. (dB/m)	Raw Rec (dBuV)
57.70	27.1	39.1	11.9	2.5	120	100.0	V	319	6.9	-32.7	13.3	39.6
69.18	31.3	39.1	7.8	2.5	120	200.0	V	212	7.0	-32.7	9.9	47.1
72.79	30.7	39.1	8.4	2.5	120	300.0	V	78	7.0	-32.7	8.9	47.4
150.50	31.1	43.5	12.5	2.5	120	100.0	V	26	7.7	-32.6	8.2	47.8
203.52	35.3	43.5	8.2	2.5	120	100.0	V	306	8.0	-32.6	11.2	48.7
234.78	30.4	46.4	16.0	2.5	120	400.0	H	276	8.2	-32.6	12.0	42.8

**NOTE** : Quasi Peaks are not measured because Peak Data meet Quasi-Peak limit.

EUT Configuration: EUT 1

Above 1 000 MHz (Peak Measurement)

Operating mode: D(WiFi Print (5 G))

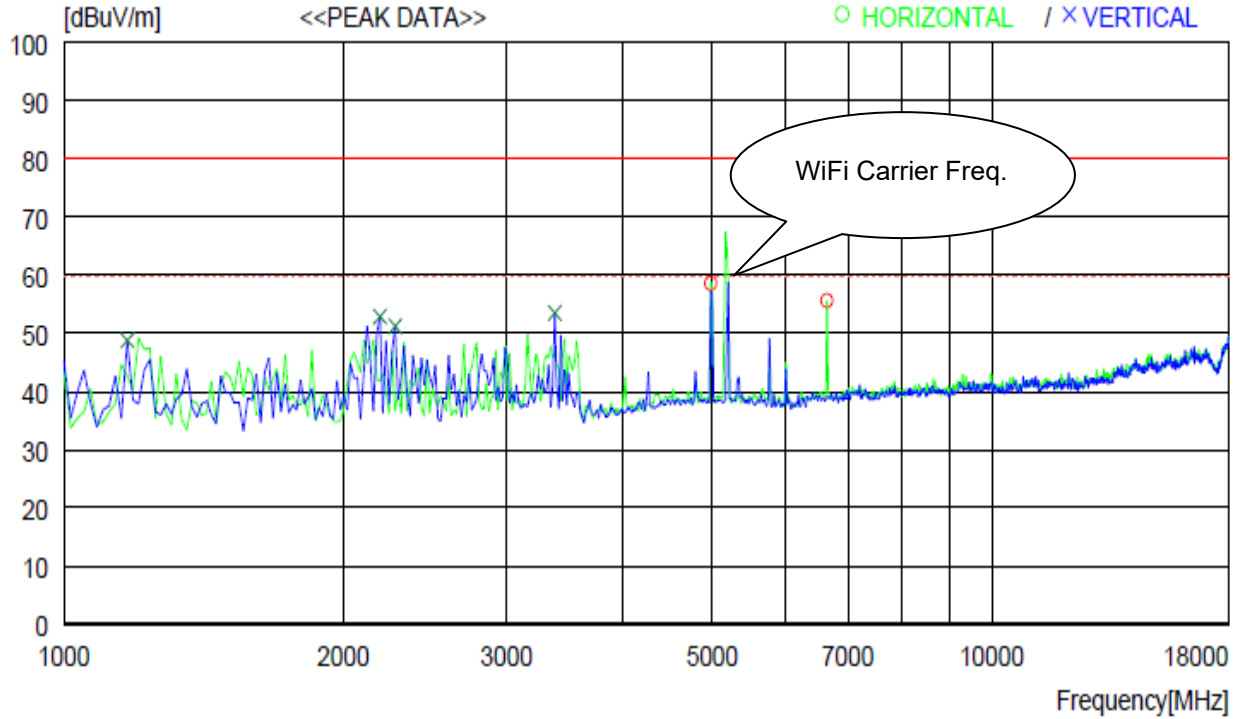

No.	FREQ [MHz]	READING [dBuV]	ANT PEAK FACTOR [dB]	LOSS [dB]	GAIN [dB]	RESULT [dBuV/m]	LIMIT [dBuV/m]	MARGIN [dB]	ANTENNA [cm]	TABLE [DEG]
----- Horizontal -----										
1	4978.000	52.5	33.8	12.1	39.8	58.6	80.0	21.4	153	359
2	6644.000	47.1	34.8	13.6	39.9	55.6	80.0	24.4	153	190
----- Vertical -----										
3	1170.000	58.3	24.7	5.8	40.0	48.8	80.0	31.2	277	359
4	2190.000	56.8	28.4	7.6	39.9	52.9	80.0	27.1	277	359
5	2275.000	54.6	28.5	7.9	39.8	51.2	80.0	28.8	277	359
6	3380.000	52.4	31.3	9.9	40.1	53.5	80.0	26.5	277	359

EUT Configuration: EUT 1

Above 1 000 MHz (Average Measurement )

Operating mode: D(WiFi Print (5 G))

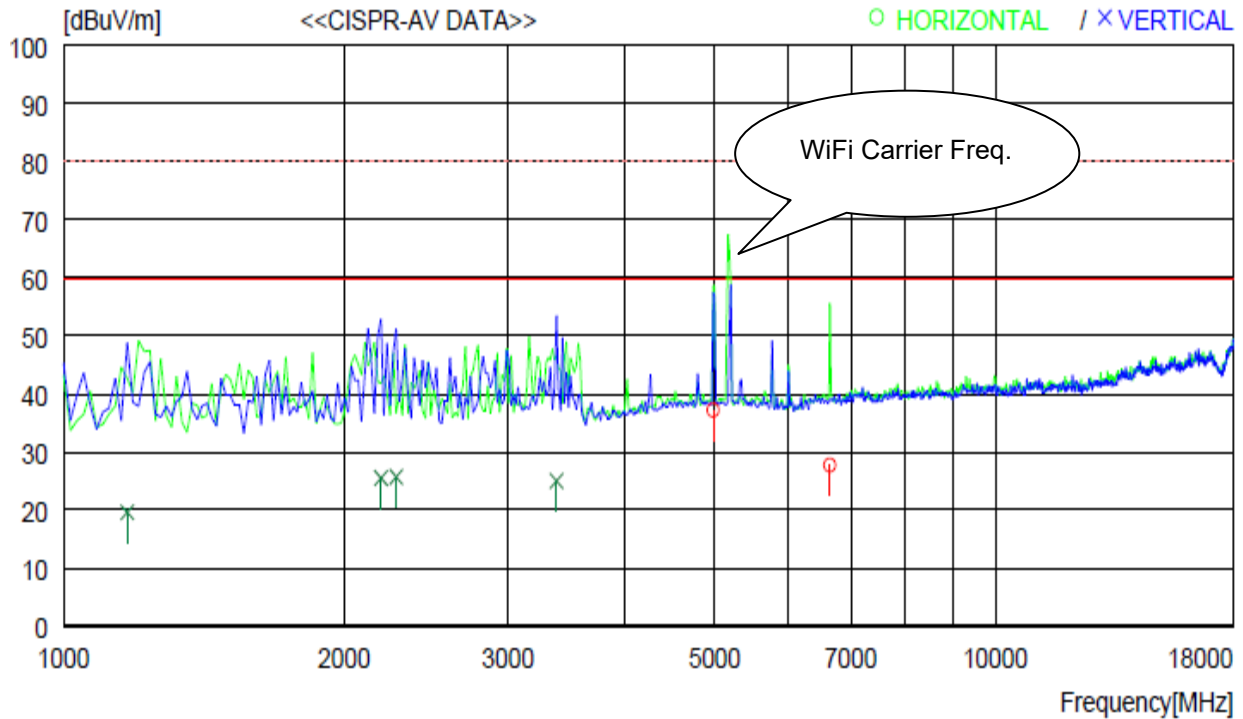

No.	FREQ [MHz]	READING CAV [dBuV]	ANT FACTOR [dB]	LOSS [dB]	GAIN [dB]	RESULT [dBuV/m]	LIMIT [dBuV/m]	MARGIN [dB]	ANTENNA [cm]	TABLE [DEG]
----- Horizontal -----										
1	4978.000	31.1	33.8	12.1	39.8	37.2	60.0	22.8	153	359
2	6644.000	19.2	34.8	13.6	39.9	27.7	60.0	32.3	153	190
----- Vertical -----										
3	1170.000	29.1	24.7	5.8	40.0	19.6	60.0	40.4	277	359
4	2190.000	29.4	28.4	7.6	39.9	25.5	60.0	34.5	277	359
5	2275.000	29.1	28.5	7.9	39.8	25.7	60.0	34.3	277	359
6	3380.000	23.9	31.3	9.9	40.1	25.0	60.0	35.0	277	359

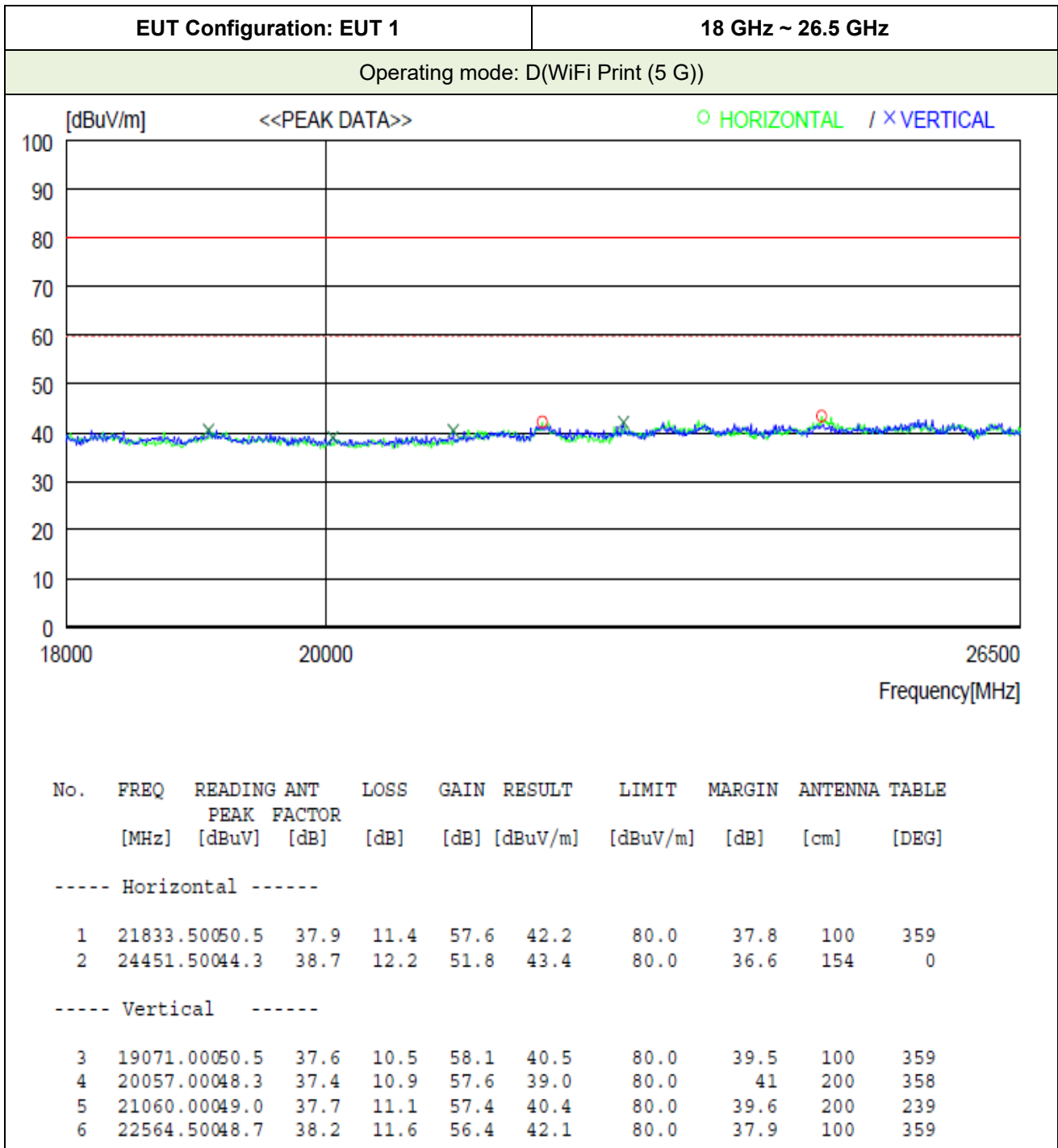



EUT Configuration: EUT 1

30 MHz ~ 1 000 MHz

Operating mode: F(Copy)

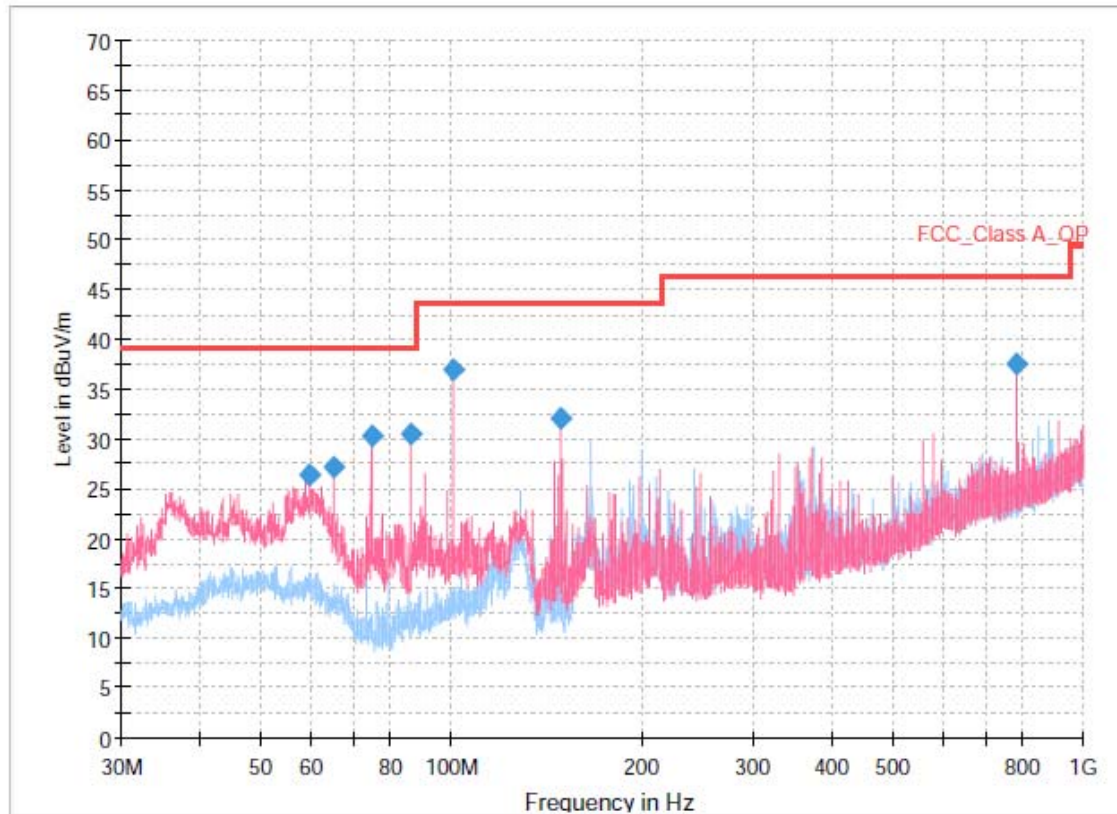

### Final Result

Frequency (MHz)	MaxPeak (dBuV/m)	Limit (dBuV/m)	Margin (dB)	Meas. Time (ms)	Band width (kHz)	Height (cm)	Pol	Azimuth (deg)	Sig Path (dB)	Preamp (dB)	Trd Corr. (dB/m)	Raw Rec (dBuV)
59.69	26.4	39.1	12.6	2.5	120	300.0	V	7	6.9	-32.7	13.0	39.2
65.30	27.2	39.1	11.9	2.5	120	100.0	V	256	7.0	-32.7	11.2	41.7
74.67	30.4	39.1	8.7	2.5	120	400.0	V	53	7.1	-32.7	8.4	47.6
86.42	30.5	39.1	8.6	2.5	120	100.0	V	0	7.2	-32.7	8.9	47.1
100.65	37.0	43.5	6.5	2.5	120	100.0	V	256	7.3	-32.7	11.2	51.2
149.36	32.1	43.5	11.5	2.5	120	100.0	V	278	7.7	-32.6	8.2	48.9
785.15	37.6	46.4	8.8	2.5	120	300.0	V	157	10.5	-32.9	20.8	39.2

**NOTE** : Quasi Peaks are not measured because Peak Data meet Quasi-Peak limit.

EUT Configuration: EUT 1

Above 1 000 MHz (Peak Measurement)

Operating mode: F(Copy)

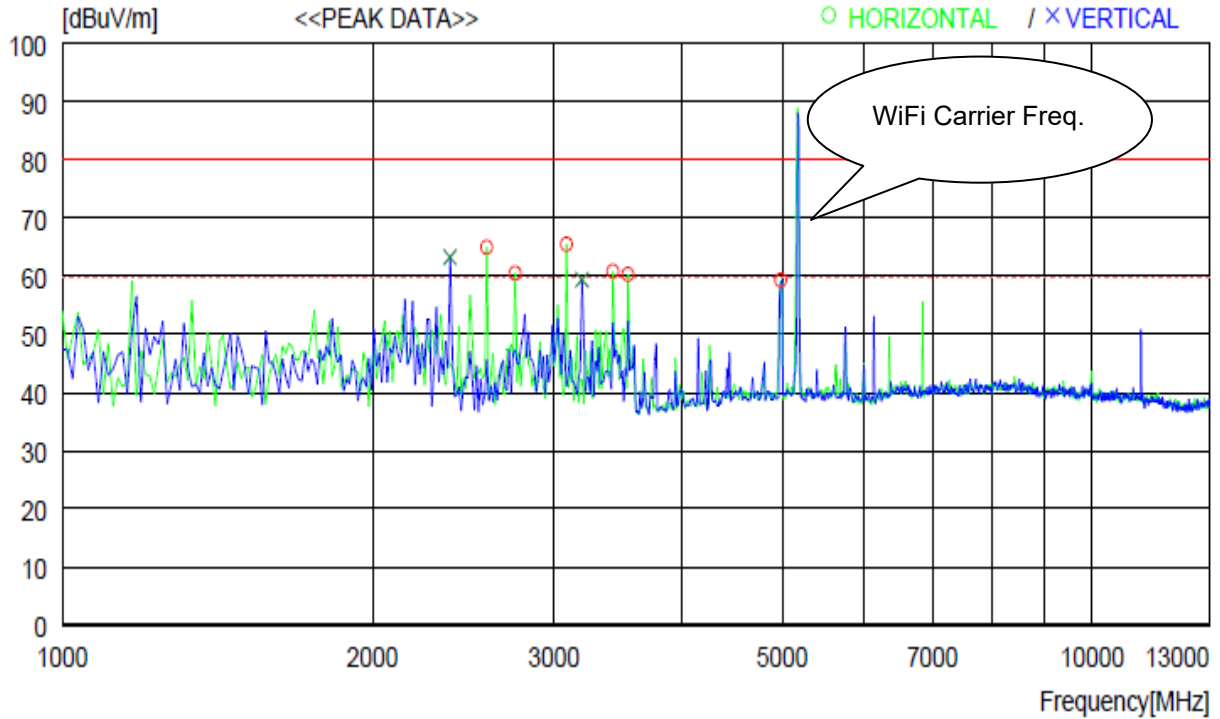

No.	FREQ [MHz]	READING [dBuV]	ANT PEAK FACTOR [dB]	LOSS [dB]	GAIN [dB]	RESULT [dBuV/m]	LIMIT [dBuV/m]	MARGIN [dB]	ANTENNA [cm]	TABLE [DEG]
----- Horizontal -----										
1	2584.000	67.2	29.0	8.6	39.8	65.0	80.0	15	200	173
2	2752.000	61.8	29.6	8.9	39.8	60.5	80.0	19.5	300	359
3	3088.000	65.2	30.6	9.6	39.9	65.5	80.0	14.5	300	359
4	3424.000	59.5	31.4	10.0	40.1	60.8	80.0	19.2	100	183
5	3544.000	58.9	31.6	10.0	40.2	60.3	80.0	19.7	200	110
6	4984.000	53.1	33.9	12.1	39.8	59.3	80.0	20.7	200	0
----- Vertical -----										
7	2380.000	66.1	28.6	8.4	39.8	63.3	80.0	16.7	200	253
8	3196.000	58.9	30.8	9.7	40.0	59.4	80.0	20.6	100	31

EUT Configuration: EUT 1

Above 1 000 MHz (Average Measurement )

Operating mode: F(Copy)

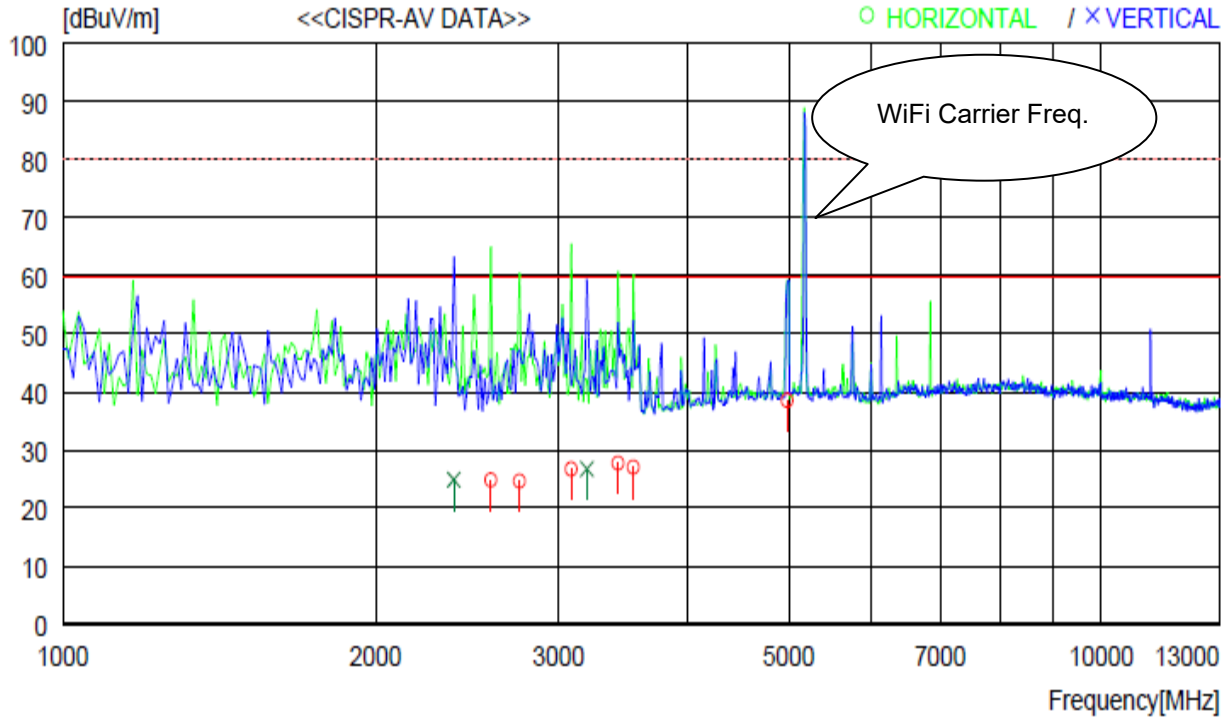

No.	FREQ [MHz]	READING CAV [dBuV]	ANT FACTOR [dB]	LOSS [dB]	GAIN [dB]	RESULT [dBuV/m]	LIMIT [dBuV/m]	MARGIN [dB]	ANTENNA [cm]	TABLE [DEG]
----- Horizontal -----										
1	2584.000	27.0	29.0	8.6	39.8	24.8	60.0	35.2	200	173
2	2752.000	25.9	29.6	8.9	39.8	24.6	60.0	35.4	300	359
3	3088.000	26.4	30.6	9.6	39.9	26.7	60.0	33.3	300	359
4	3424.000	26.4	31.4	10.0	40.1	27.7	60.0	32.3	100	183
5	3544.000	25.6	31.6	10.0	40.2	27.0	60.0	33.0	200	110
6	4984.000	32.3	33.9	12.1	39.8	38.5	60.0	21.5	200	0
----- Vertical -----										
7	2380.000	27.7	28.6	8.4	39.8	24.9	60.0	35.1	200	253
8	3196.000	26.2	30.8	9.7	40.0	26.7	60.0	33.3	100	31

EUT Configuration: EUT 1

30 MHz ~ 1 000 MHz

Operating mode: H(WiFi Scan (2.4 G))

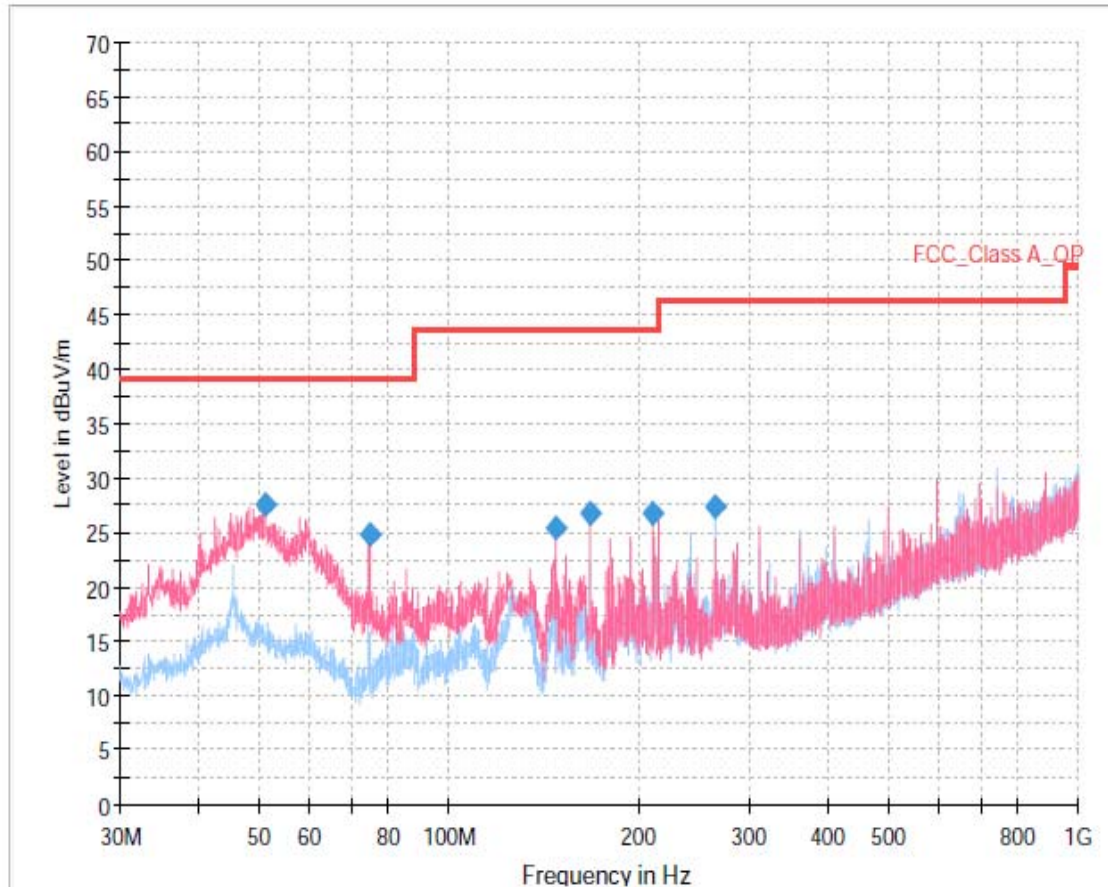

### Final Result

Frequency (MHz)	MaxPeak (dBuV/m)	Limit (dBuV/m)	Margin (dB)	Meas. Time (ms)	Band width (kHz)	Height (cm)	Pol	Azimuth (deg)	Sig Path (dB)	Preamp (dB)	Trd Corr. (dB/m)	Raw Rec (dBuV)
51.18	27.5	39.1	11.6	2.5	120	200.0	V	337	6.8	-32.7	14.3	39.1
74.67	24.8	39.1	14.3	2.5	120	200.0	V	47	7.1	-32.7	8.4	42.0
147.59	25.4	43.5	18.1	2.5	120	100.0	V	0	7.7	-32.6	8.1	42.3
167.96	26.7	43.5	16.8	2.5	120	100.0	V	155	7.8	-32.6	8.7	42.8
210.47	26.8	43.5	16.7	2.5	120	100.0	V	336	8.1	-32.6	11.4	40.0
264.04	27.3	46.4	19.1	2.5	120	300.0	H	161	8.4	-32.6	12.7	38.9

**NOTE** : Quasi Peaks are not measured because Peak Data meet Quasi-Peak limit.

EUT Configuration: EUT 1

Above 1 000 MHz (Peak Measurement)

Operating mode: H(WiFi Scan (2.4 G))

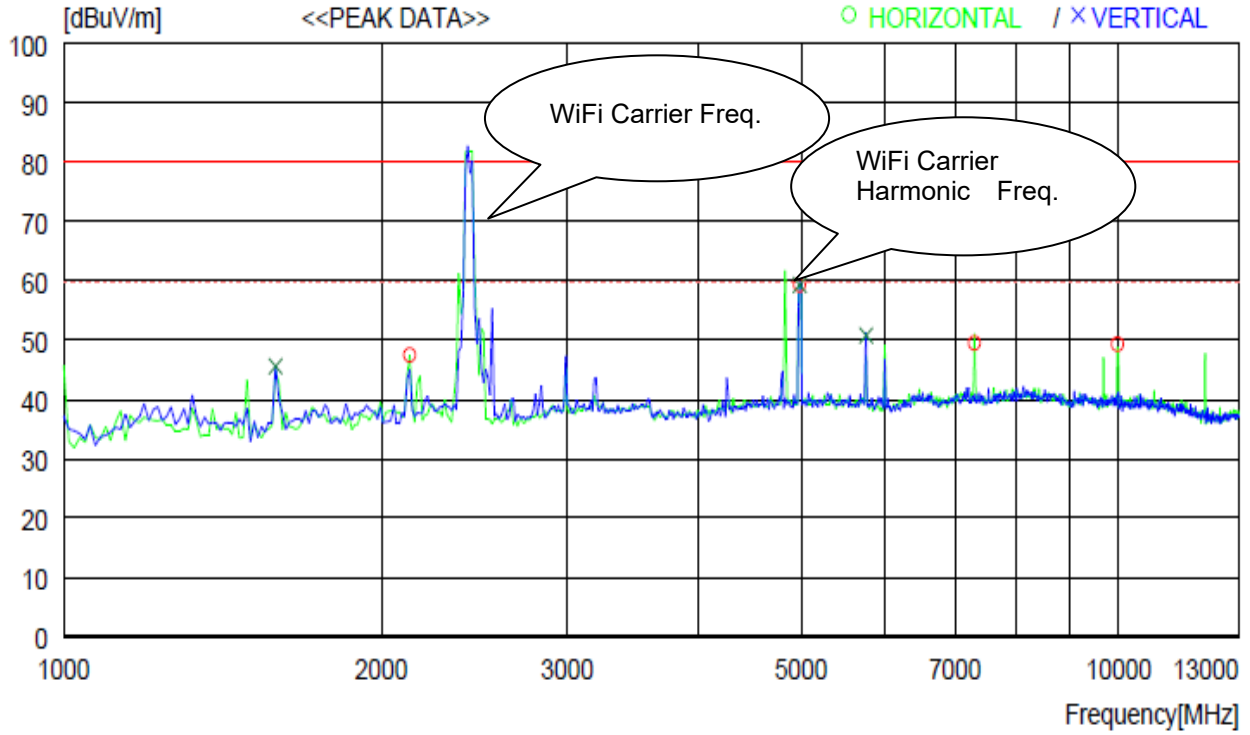

No.	FREQ [MHz]	READING [dBuV]	ANT PEAK FACTOR [dB]	LOSS [dB]	GAIN [dB]	RESULT [dBuV/m]	LIMIT [dBuV/m]	MARGIN [dB]	ANTENNA [cm]	TABLE [DEG]
----- Horizontal -----										
1	2128.000	51.6	28.3	7.5	39.9	47.5	80.0	32.5	300	359
2	4984.000	53.1	33.9	12.1	39.8	59.3	80.0	20.7	300	43
3	7300.000	41.5	35.2	12.9	40.1	49.5	80.0	30.5	300	359
4	9976.000	38.3	36.7	14.0	39.7	49.3	80.0	30.7	100	359
----- Vertical -----										
5	1588.000	52.9	26.0	6.6	39.9	45.6	80.0	34.4	200	246
6	4984.000	53.5	33.9	11.7	39.8	59.3	80.0	20.7	200	359
7	5764.000	44.4	34.1	12.1	39.8	50.8	80.0	29.2	200	98

EUT Configuration: EUT 1

Above 1 000 MHz (Average Measurement )

Operating mode: H(WiFi Scan (2.4 G))

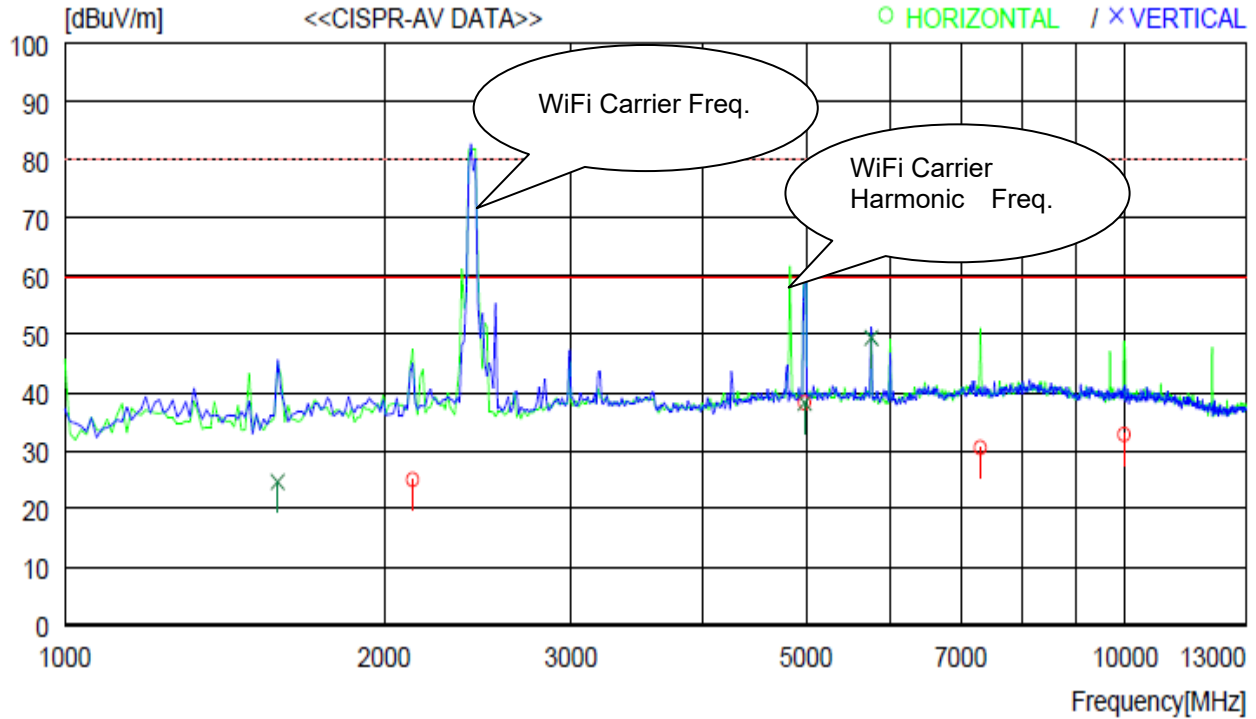

No.	FREQ [MHz]	READING CAV [dBuV]	ANT FACTOR [dB]	LOSS [dB]	GAIN [dB]	RESULT [dBuV/m]	LIMIT [dBuV/m]	MARGIN [dB]	ANTENNA [cm]	TABLE [DEG]
----- Horizontal -----										
1	2128.000	29.1	28.3	7.5	39.9	25.0	60.0	35.0	300	359
2	4984.000	32.0	33.9	12.1	39.8	38.2	60.0	21.8	300	43
3	7300.000	21.0	35.2	14.0	39.7	30.5	60.0	29.5	300	359
4	9976.000	22.3	36.7	14.3	40.5	32.8	60.0	27.2	100	359
----- Vertical -----										
5	4984.000	32.0	33.9	12.1	39.8	38.2	60.0	21.8	200	359
6	5764.000	42.5	34.1	12.9	40.1	49.4	60.0	10.6	200	98
7	1588.000	31.9	26.0	6.6	39.9	24.6	60.0	35.4	200	246

EUT Configuration: EUT 1

30 MHz ~ 1 000 MHz

Operating mode: J(USB Memory Stick Scan)

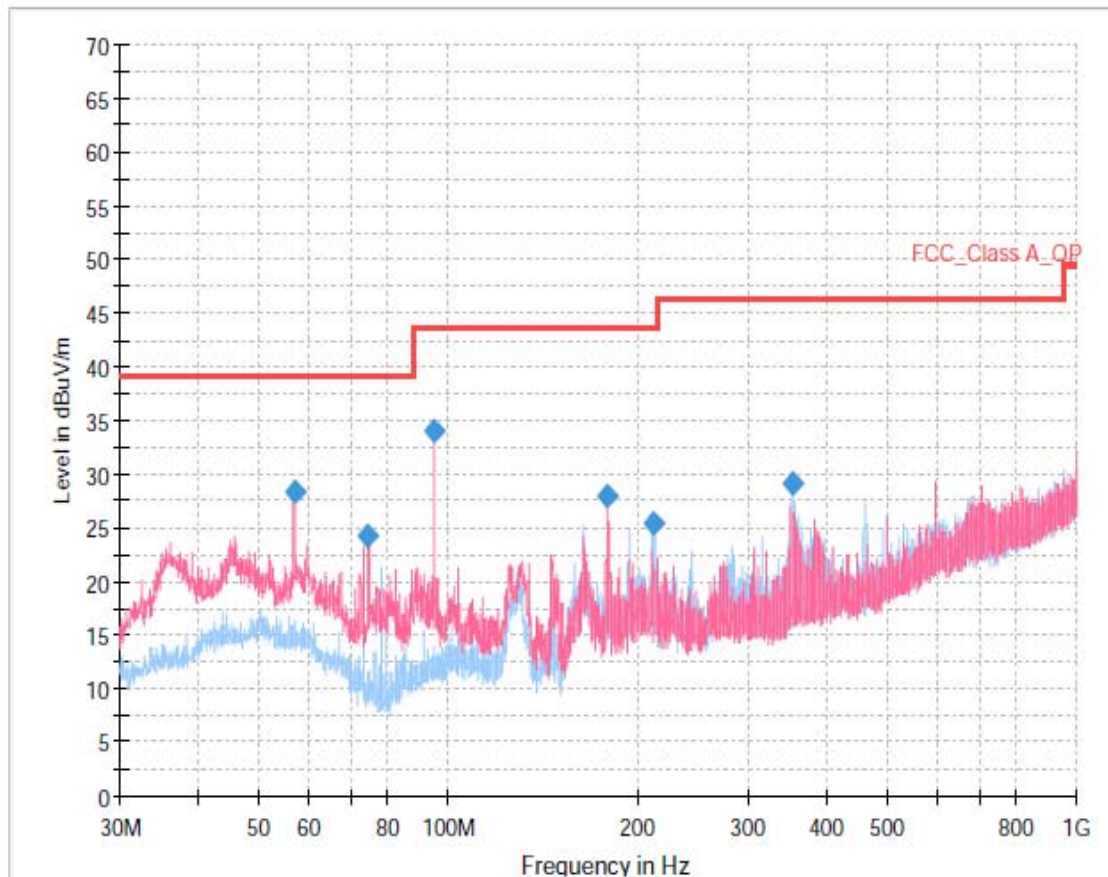

## Final Result

Frequency (MHz)	MaxPeak (dBuV/m)	Limit (dBuV/m)	Margin (dB)	Meas. Time (ms)	Band width (kHz)	Height (cm)	Pol	Azimuth (deg)	Sig Path (dB)	Preamp (dB)	Trd Corr. (dB/m)	Raw Rec (dBuV)
56.89	28.4	39.1	10.7	2.5	120	300.0	V	148	6.9	-32.7	13.4	40.7
74.46	24.3	39.1	14.8	2.5	120	200.0	V	302	7.1	-32.7	8.5	41.4
94.88	34.0	43.5	9.6	2.5	120	100.0	V	62	7.3	-32.7	10.5	48.8
178.79	28.0	43.5	15.5	2.5	120	100.0	V	351	7.9	-32.6	9.1	43.7
212.68	25.4	43.5	18.1	2.5	120	400.0	H	100	8.1	-32.6	11.5	38.5
353.28	29.0	46.4	17.4	2.5	120	200.0	H	40	8.8	-32.7	14.5	38.4

**NOTE** : Quasi Peaks are not measured because Peak Data meet Quasi-Peak limit.

EUT Configuration: EUT 1

Above 1 000 MHz (Peak Measurement)

Operating mode: J(USB Memory Stick Scan)

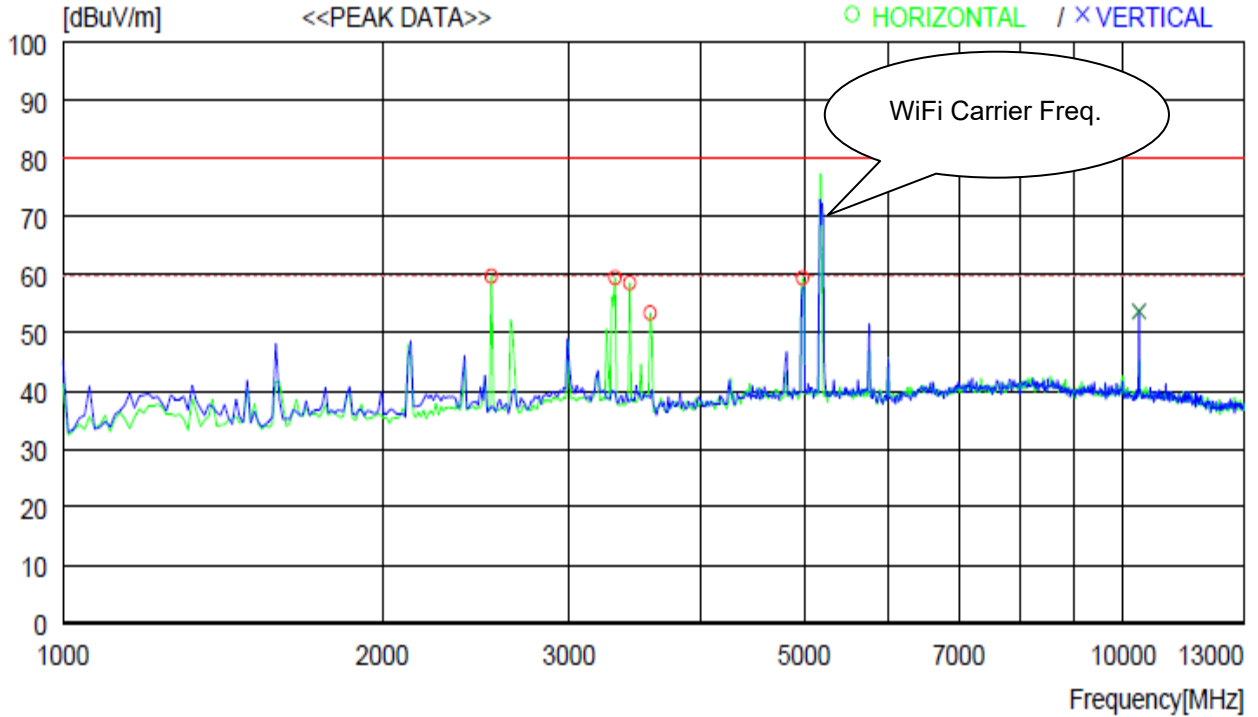

No.	FREQ [MHz]	READING [dBuV]	ANT PEAK FACTOR [dB]	LOSS [dB]	GAIN [dB]	RESULT [dBuV/m]	LIMIT [dBuV/m]	MARGIN [dB]	ANTENNA [cm]	TABLE [DEG]
----- Horizontal -----										
1	2536.000	62.2	28.8	8.5	39.8	59.7	80.0	20.3	300	205
2	3316.000	58.6	31.1	9.8	40.0	59.5	80.0	20.5	200	326
3	3424.000	57.3	31.4	10.0	40.1	58.6	80.0	21.4	300	359
4	3580.000	51.9	31.7	10.0	40.2	53.4	80.0	26.6	300	359
5	4984.000	53.2	33.9	12.1	39.8	59.4	80.0	20.6	200	354
----- Vertical -----										
6	10348.000	43.2	36.6	14.3	40.4	53.7	80.0	26.3	300	0



EUT Configuration: EUT 1

Above 1 000 MHz (Average Measurement )

Operating mode: J(USB Memory Stick Scan)

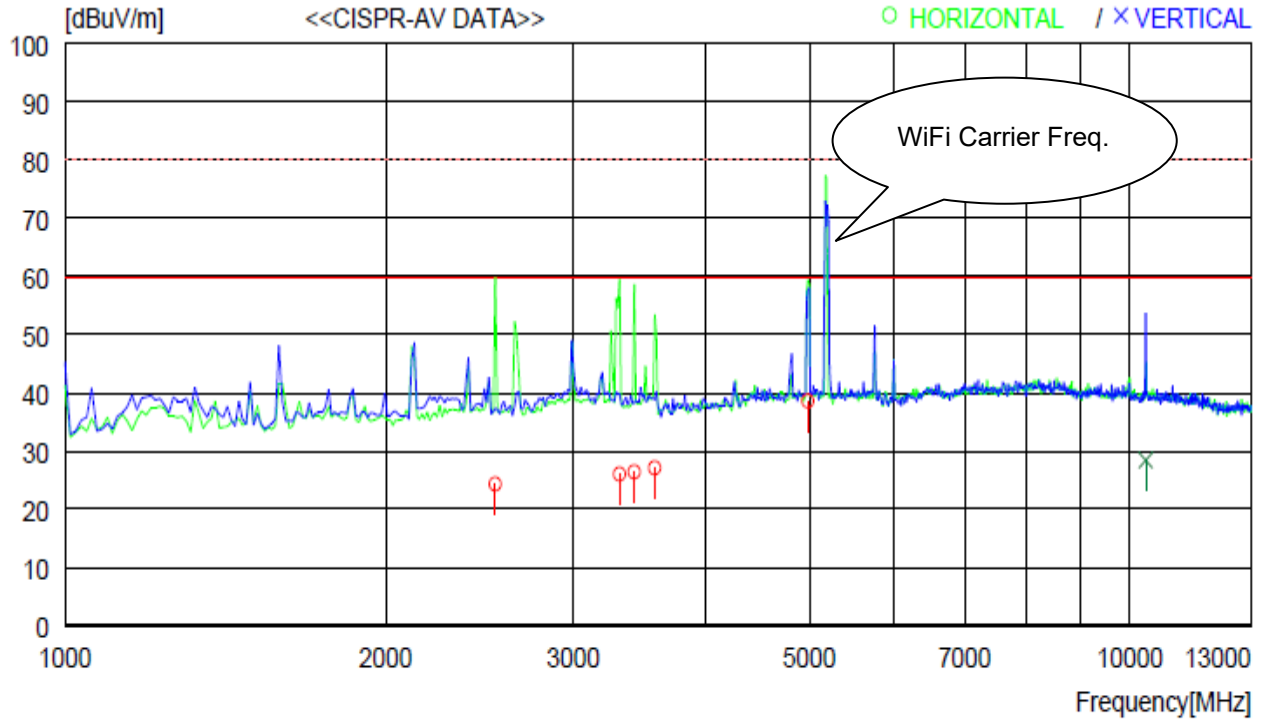

No.	FREQ [MHz]	READING CAV [dBuV]	ANT FACTOR [dB]	LOSS [dB]	GAIN [dB]	RESULT [dBuV/m]	LIMIT [dBuV/m]	MARGIN [dB]	ANTENNA [cm]	TABLE [DEG]
----- Horizontal -----										
1	2536.000	26.8	28.8	8.5	39.8	24.3	60.0	35.7	300	205
2	3316.000	25.1	31.1	9.8	40.0	26.0	60.0	34.0	200	326
3	3424.000	25.1	31.4	10.0	40.1	26.4	60.0	33.6	300	359
4	3580.000	25.6	31.7	10.0	40.2	27.1	60.0	32.9	300	359
5	4984.000	32.4	33.9	12.1	39.8	38.6	60.0	21.4	200	354
----- Vertical -----										
6	10348.000	17.9	36.6	14.3	40.4	28.4	60.0	31.6	300	0

EUT Configuration: EUT 1

30 MHz ~ 1 000 MHz

Operating mode: K(Fax Tx)

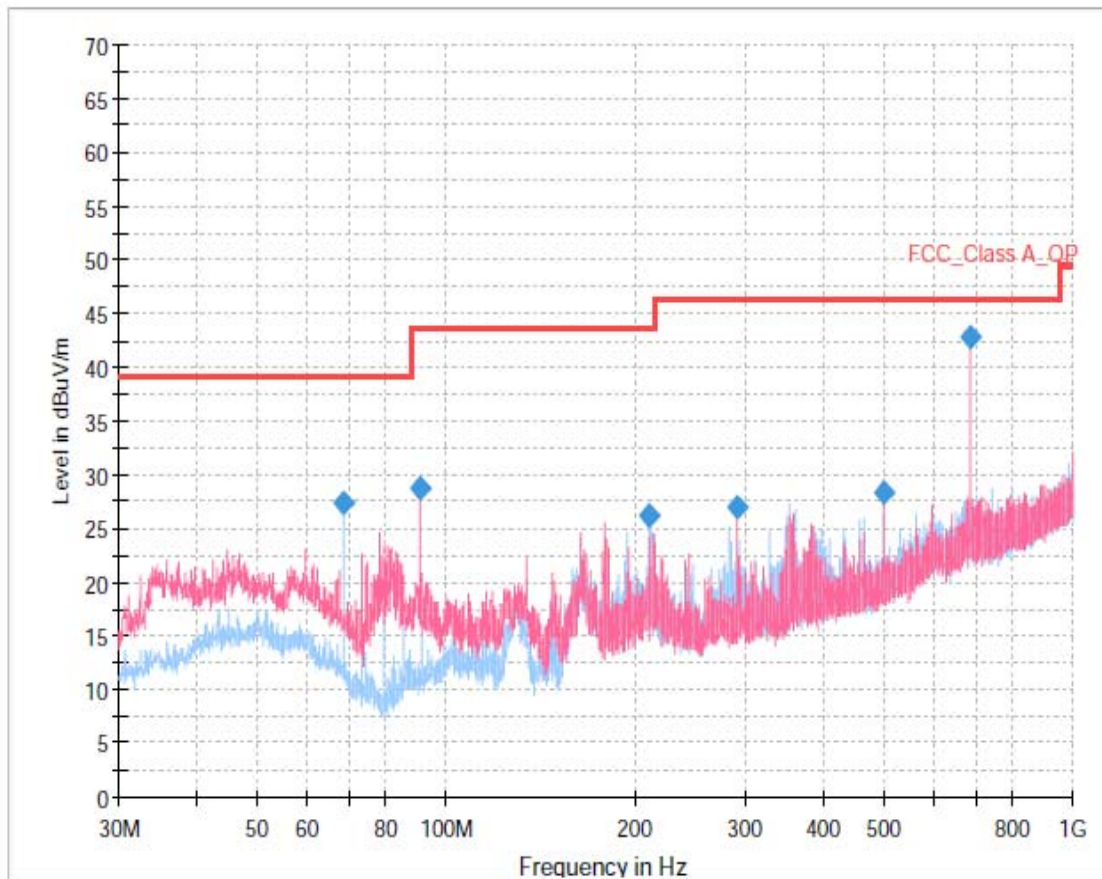

### Final Result

Frequency (MHz)	MaxPeak (dBuV/m)	Limit (dBuV/m)	Margin (dB)	Meas. Time (ms)	Band width (kHz)	Height (cm)	Pol	Azimuth (deg)	Sig Path (dB)	Preamp (dB)	Trd Corr. (dB/m)	Raw Rec (dBuV)
68.64	27.3	39.1	11.7	2.5	120	400.0	H	281	7.0	-32.7	10.1	42.9
90.63	28.7	43.5	14.8	2.5	120	300.0	V	308	7.2	-32.7	10.0	44.2
210.26	26.2	43.5	17.3	2.5	120	400.0	H	0	8.1	-32.6	11.4	39.4
291.95	27.1	46.4	19.3	2.5	120	100.0	V	103	8.5	-32.6	13.1	38.1
500.02	28.3	46.4	18.1	2.5	120	100.0	V	177	9.4	-32.8	17.3	34.4
684.32	42.9	46.4	3.5	2.5	120	300.0	V	7	10.1	-33.0	19.8	46.0

**NOTE** : Quasi Peaks are not measured because Peak Data meet Quasi-Peak limit.

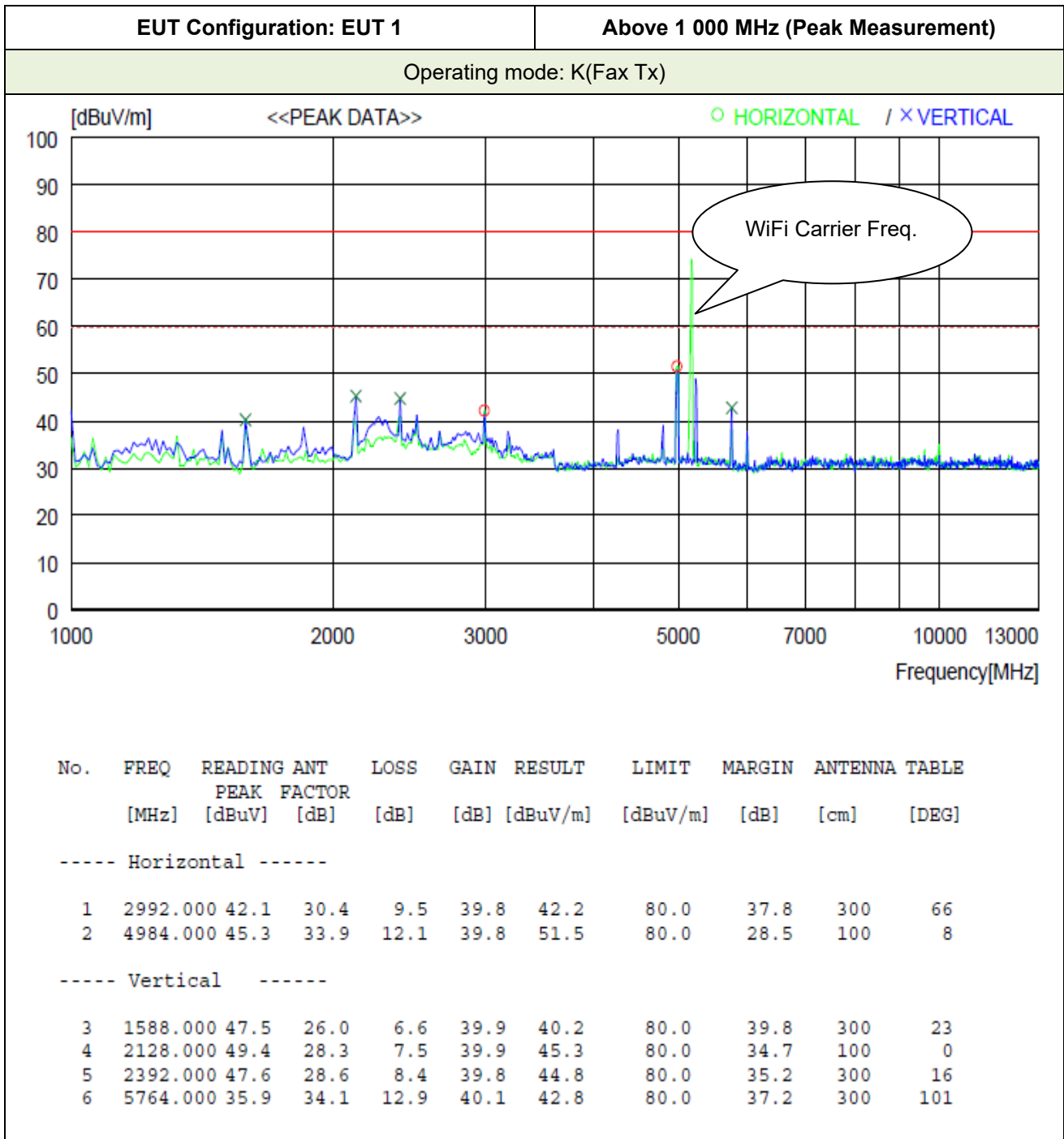

**NOTE:** Average mode was not measured, because Peak values were under the Average limit.

EUT Configuration: EUT 1

30 MHz ~ 1 000 MHz

Operating mode: L(Fax Rx)

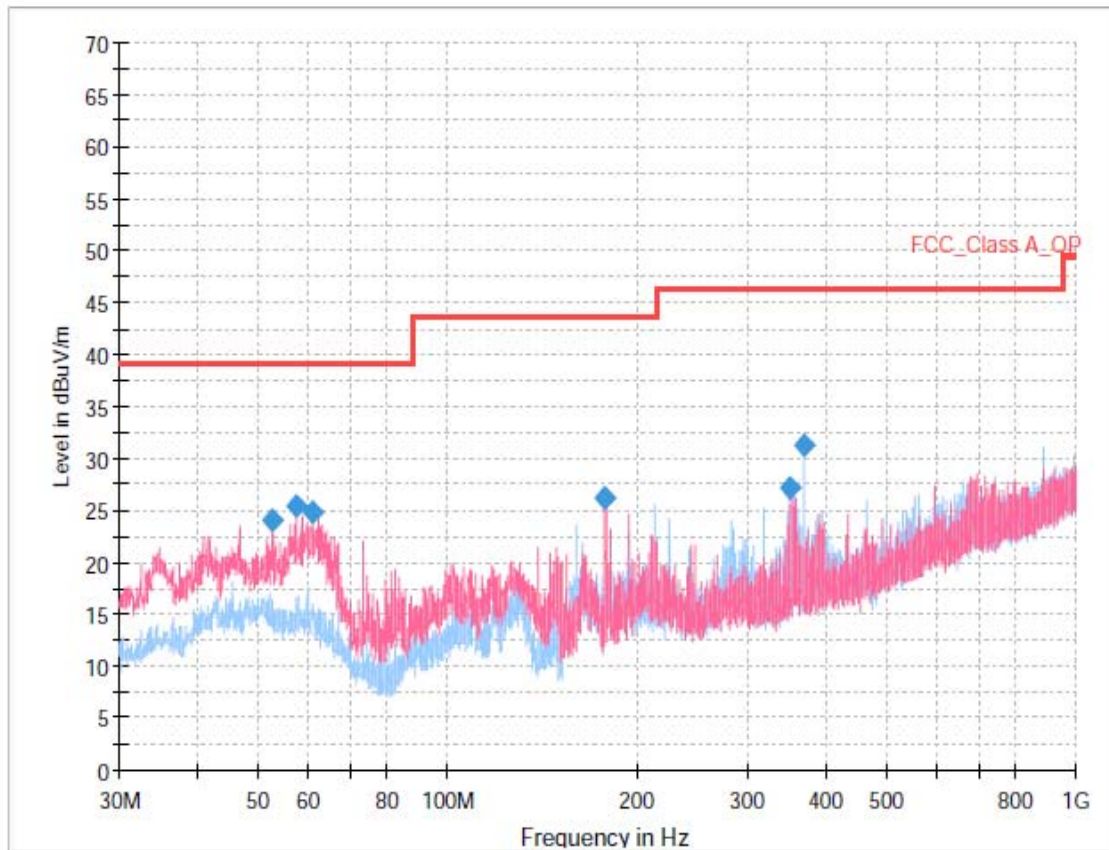

### Final Result

Frequency (MHz)	MaxPeak (dBuV/m)	Limit (dBuV/m)	Margin (dB)	Meas. Time (ms)	Band width (kHz)	Height (cm)	Pol	Azimuth (deg)	Sig Path (dB)	Preamp (dB)	Trd Corr. (dB/m)	Raw Rec (dBuV)
52.74	24.1	39.1	14.9	2.5	120	100.0	V	0	6.8	-32.7	14.0	35.9
57.48	25.5	39.1	13.6	2.5	120	100.0	V	8	6.9	-32.7	13.3	37.9
60.82	24.9	39.1	14.2	2.5	120	200.0	V	246	6.9	-32.7	12.7	37.9
178.30	26.2	43.5	17.3	2.5	120	100.0	V	0	7.9	-32.6	9.1	41.9
350.91	27.1	46.4	19.3	2.5	120	200.0	H	26	8.8	-32.7	14.5	36.6
369.07	31.3	46.4	15.1	2.5	120	200.0	H	249	8.9	-32.7	14.9	40.3

**NOTE** : Quasi Peaks are not measured because Peak Data meet Quasi-Peak limit.

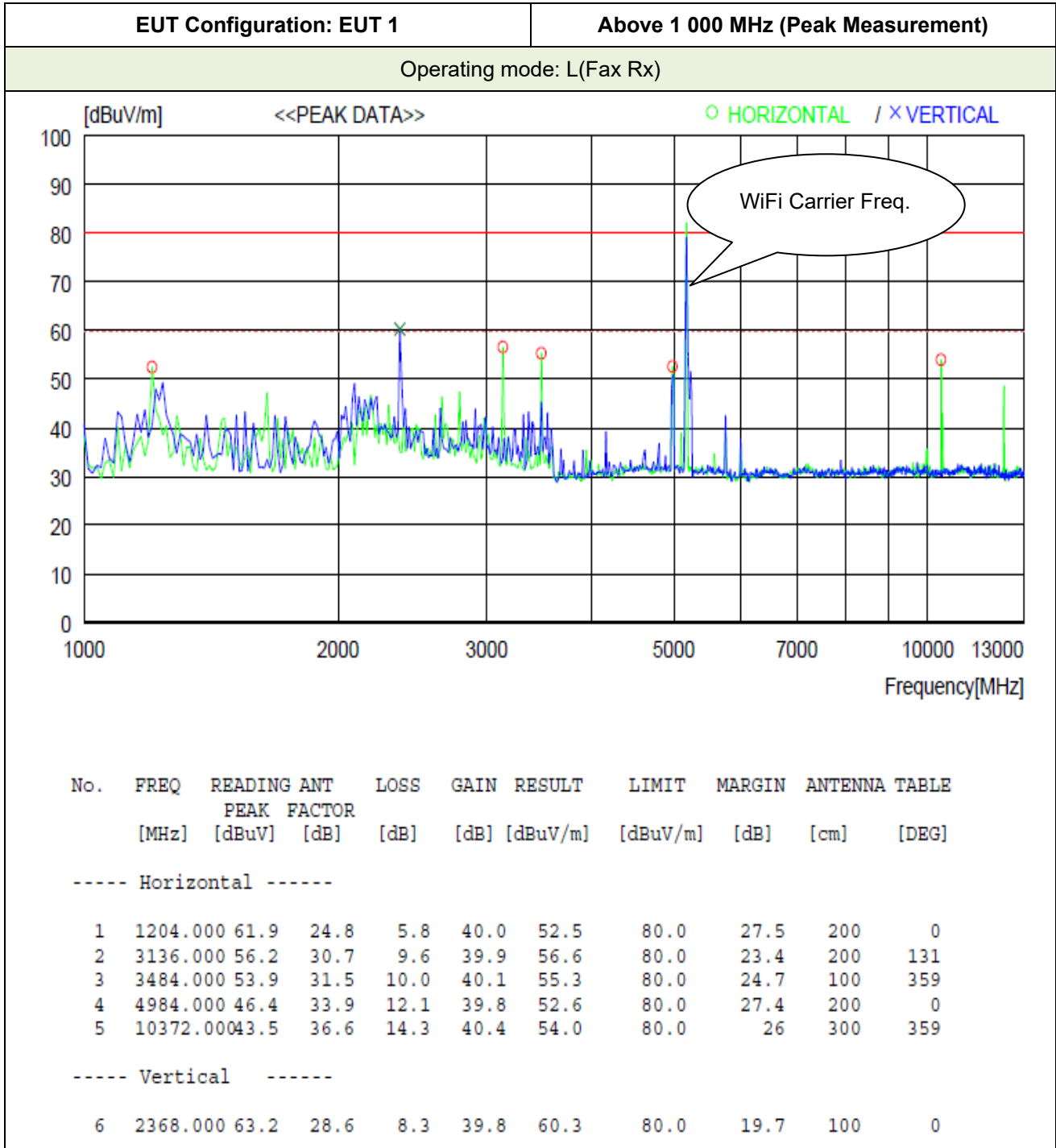

EUT Configuration: EUT 1

Above 1 000 MHz (Average Measurement )

Operating mode: L(Fax Rx)

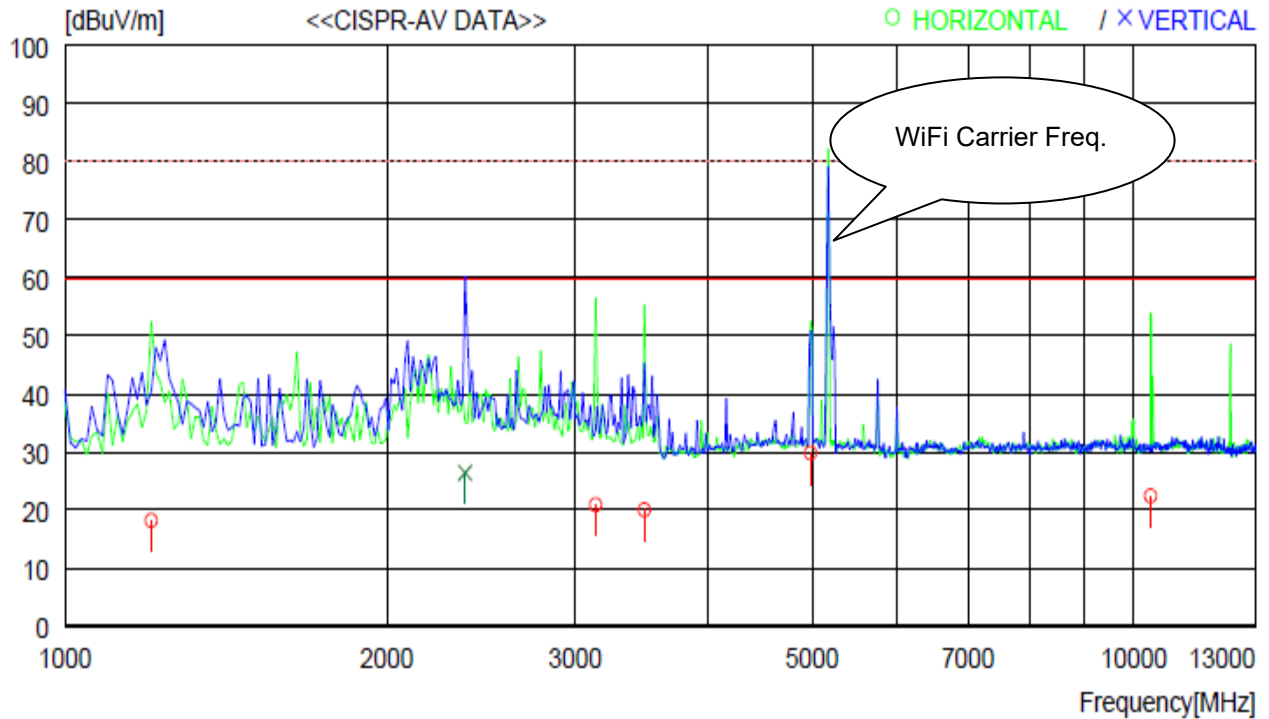

No.	FREQ [MHz]	READING CAV [dBuV]	ANT FACTOR [dB]	LOSS [dB]	GAIN [dB]	RESULT [dBuV/m]	LIMIT [dBuV/m]	MARGIN [dB]	ANTENNA [cm]	TABLE [DEG]
----- Horizontal -----										
1	1204.000	27.6	24.8	5.8	40.0	18.2	60.0	41.8	200	0
2	3136.000	20.5	30.7	9.6	39.9	20.9	60.0	39.1	200	131
3	3484.000	18.6	31.5	10.0	40.1	20.0	60.0	40.0	100	359
4	4984.000	23.6	33.9	12.1	39.8	29.8	60.0	30.2	200	0
5	10372.000	11.9	36.6	14.3	40.4	22.4	60.0	37.6	300	359
----- Vertical -----										
6	2368.000	29.3	28.6	8.3	39.8	26.4	60.0	33.6	100	0

EUT Configuration: *EUT 2*

30 MHz ~ 1 000 MHz

Operating mode: C(WiFi Print (2.4 G))

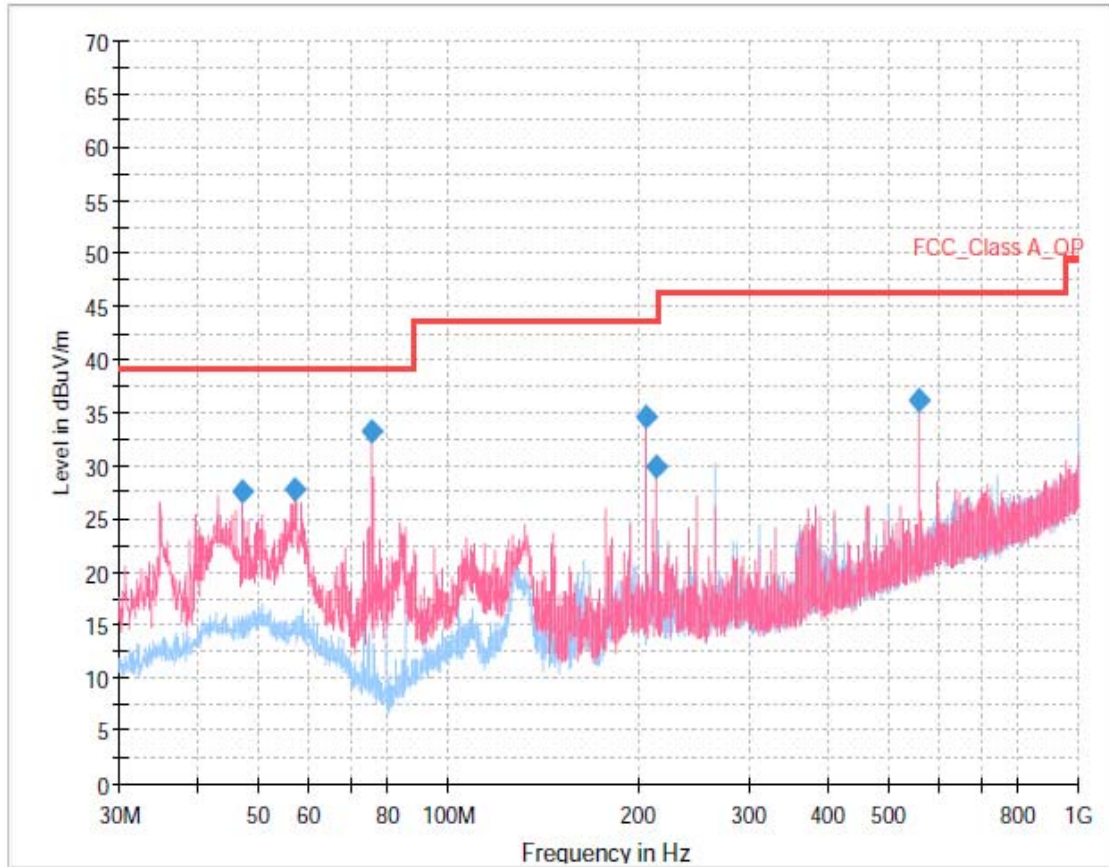

### Final Result

Frequency (MHz)	MaxPeak (dBuV/m)	Limit (dBuV/m)	Margin (dB)	Meas. Time (ms)	Band width (kHz)	Height (cm)	Pol	Azimuth (deg)	Sig Path (dB)	Preamp (dB)	Trd Corr. (dB/m)	Raw Rec (dBuV)
47.08	27.5	39.1	11.5	2.5	120	400.0	V	0	6.8	-32.7	14.3	39.2
56.94	27.7	39.1	11.4	2.5	120	100.0	V	248	6.9	-32.7	13.4	40.1
75.70	33.3	39.1	5.8	2.5	120	400.0	V	330	7.1	-32.7	8.1	50.8
206.06	34.6	43.5	8.9	2.5	120	400.0	V	308	8.0	-32.6	11.3	47.9
214.08	29.8	43.5	13.7	2.5	120	100.0	V	320	8.1	-32.6	11.5	42.9
556.55	36.3	46.4	10.1	2.5	120	400.0	V	308	9.7	-32.9	18.5	41.0

**NOTE** : Quasi Peaks are not measured because Peak Data meet Quasi-Peak limit.

EUT Configuration: **EUT 2**

Above 1 000 MHz (Peak Measurement)

Operating mode: C(WiFi Print (2.4 G))

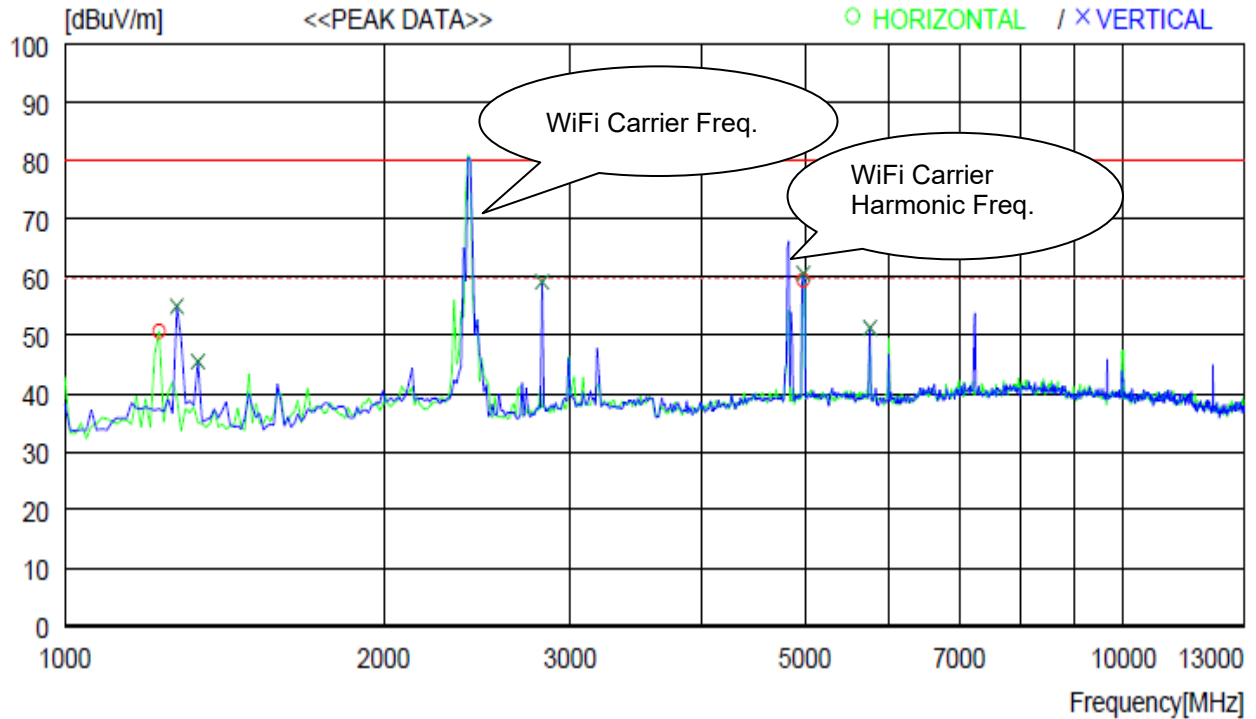

No.	FREQ [MHz]	READING [dBuV]	ANT PEAK FACTOR [dB]	LOSS [dB]	GAIN [dB]	RESULT [dBuV/m]	LIMIT [dBuV/m]	MARGIN [dB]	ANTENNA [cm]	TABLE [DEG]
----- Horizontal -----										
1	1228.000	60.0	24.8	5.9	40.0	50.7	80.0	29.3	200	329
2	4984.000	53.3	33.9	12.1	39.8	59.5	80.0	20.5	200	45
----- Vertical -----										
3	1276.000	64.0	24.9	6.0	39.9	55.0	80.0	25	200	0
4	1336.000	54.1	25.1	6.2	39.9	45.5	80.0	34.5	200	0
5	2824.000	60.2	29.8	9.0	39.8	59.2	80.0	20.8	100	359
6	4984.000	54.4	33.9	12.1	39.8	60.6	80.0	19.4	100	20
7	5764.000	44.4	34.1	12.9	40.1	51.3	80.0	28.7	200	277



EUT Configuration: *EUT 2*

Above 1 000 MHz (Average Measurement )

Operating mode: C(WiFi Print (2.4 G))

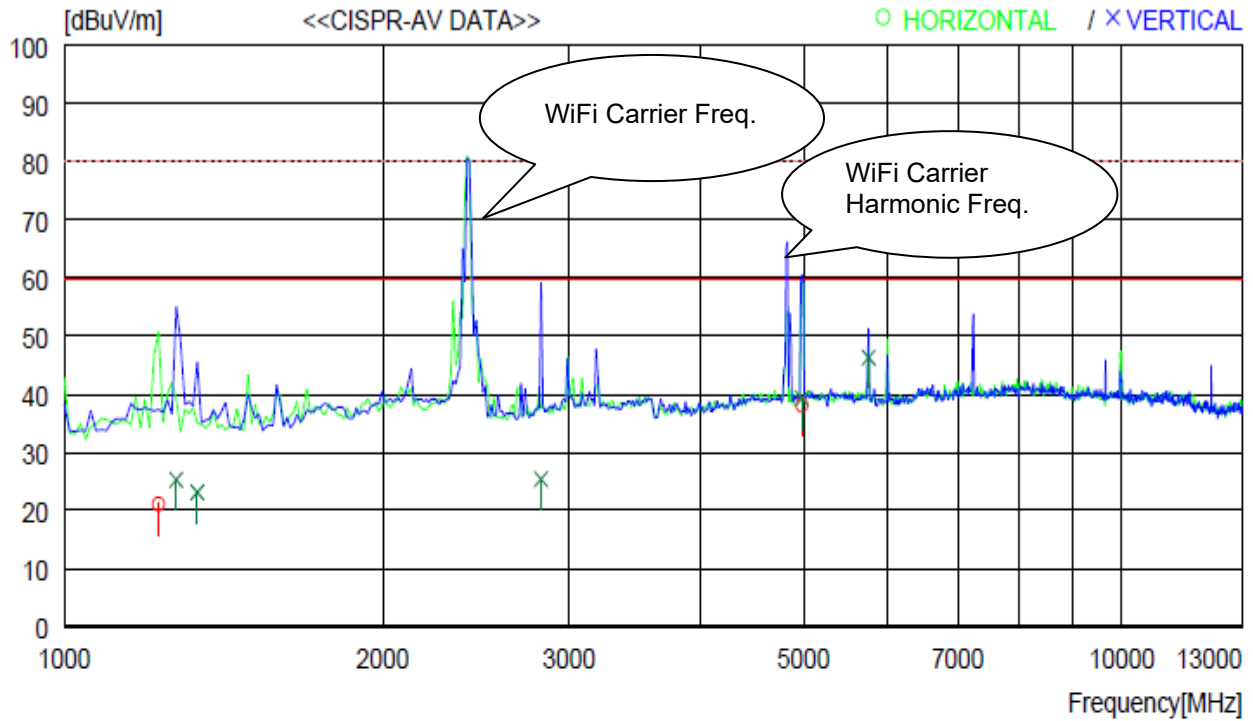

No.	FREQ [MHz]	READING CAV [dBuV]	ANT FACTOR [dB]	LOSS [dB]	GAIN [dB]	RESULT [dBuV/m]	LIMIT [dBuV/m]	MARGIN [dB]	ANTENNA [cm]	TABLE [DEG]
----- Horizontal -----										
1	1228.000	30.4	24.8	5.9	40.0	21.1	60.0	38.9	200	329
2	4984.000	31.9	33.9	12.1	39.8	38.1	60.0	21.9	200	45
----- Vertical -----										
3	1276.000	34.3	24.9	6.0	39.9	25.3	60.0	34.7	200	0
4	1336.000	31.7	25.1	6.2	39.9	23.1	60.0	36.9	200	0
5	2824.000	26.4	29.8	9.0	39.8	25.4	60.0	34.6	100	359
6	4984.000	33.1	33.9	12.1	39.8	39.3	60.0	20.7	100	20
7	5764.000	39.4	34.1	12.9	40.1	46.3	60.0	13.7	200	277

EUT Configuration: *EUT 2*

30 MHz ~ 1 000 MHz

Operating mode: G(LAN Scan)

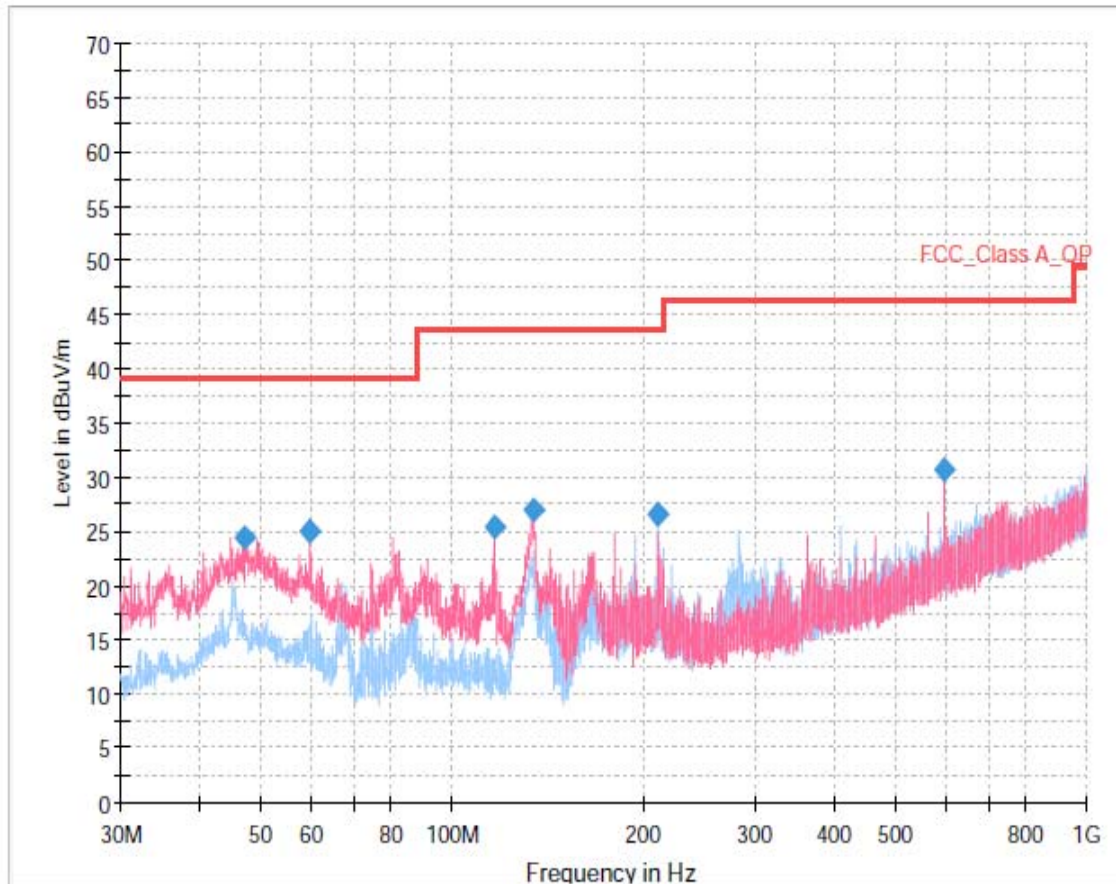

### Final Result

Frequency (MHz)	MaxPeak (dBuV/m)	Limit (dBuV/m)	Margin (dB)	Meas. Time (ms)	Band width (kHz)	Height (cm)	Pol	Azimuth (deg)	Sig Path (dB)	Preamp (dB)	Trd Corr. (dB/m)	Raw Rec (dBuV)
47.19	24.5	39.1	14.6	2.5	120	300.0	V	0	6.8	-32.7	14.3	36.1
59.59	25.1	39.1	14.0	2.5	120	100.0	V	259	6.9	-32.7	13.0	37.8
116.98	25.4	43.5	18.1	2.5	120	200.0	V	274	7.4	-32.6	9.9	40.7
133.90	27.0	43.5	16.6	2.5	120	100.0	V	259	7.6	-32.6	8.4	43.6
210.20	26.6	43.5	17.0	2.5	120	400.0	H	0	8.1	-32.6	11.4	39.7
597.45	30.7	46.4	15.7	2.5	120	400.0	V	193	9.8	-33.0	19.4	34.5

**NOTE :** Quasi Peaks are not measured because Peak Data meet Quasi-Peak limit.

EUT Configuration: **EUT 2**

Above 1 000 MHz (Peak Measurement)

Operating mode: G(LAN Scan)

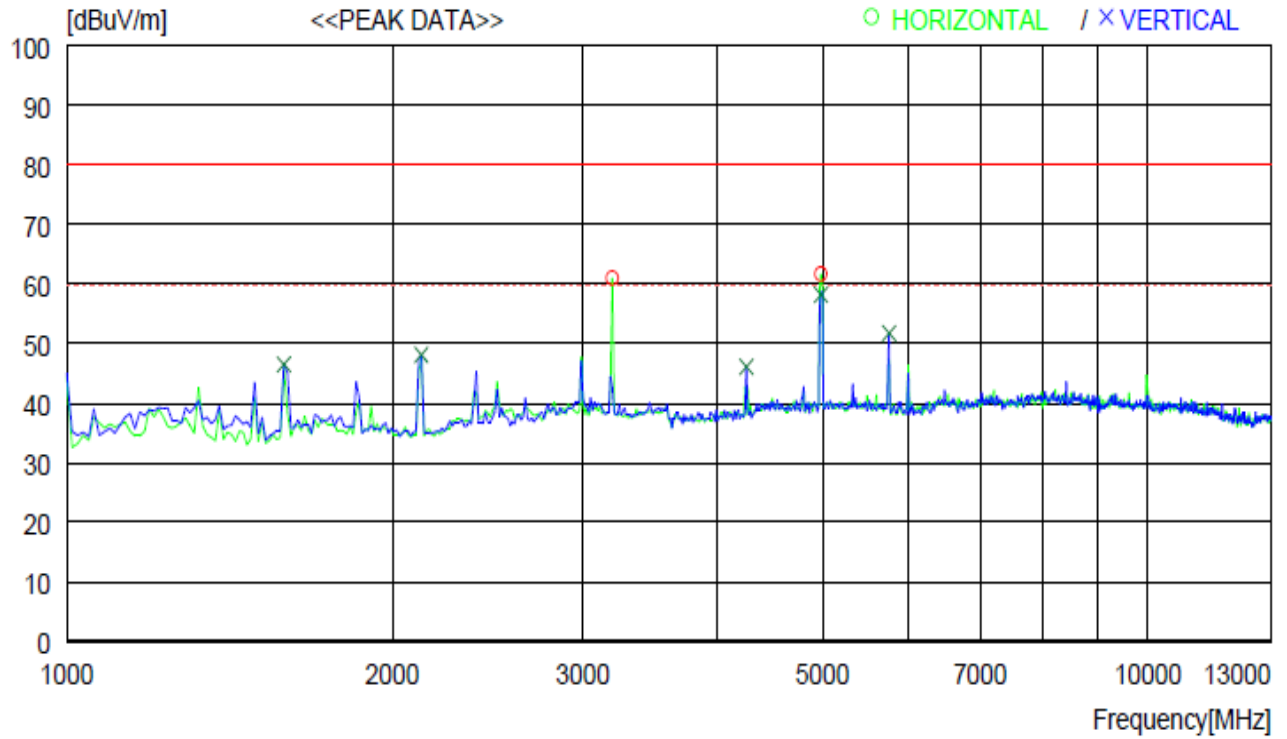

No.	FREQ [MHz]	READING [dBuV]	ANT PEAK FACTOR [dB]	LOSS [dB]	GAIN [dB]	RESULT [dBuV/m]	LIMIT [dBuV/m]	MARGIN [dB]	ANTENNA [cm]	TABLE [DEG]
----- Horizontal -----										
1	3196.000	60.5	30.8	9.7	40.0	61.0	80.0	19	200	359
2	4984.000	55.5	33.9	12.1	39.8	61.7	80.0	18.3	100	83
----- Vertical -----										
3	1588.000	53.8	26.0	6.6	39.9	46.5	80.0	33.5	300	250
4	2128.000	52.2	28.3	7.5	39.9	48.1	80.0	31.9	100	349
5	4252.000	42.2	32.9	11.0	40.0	46.1	80.0	33.9	300	359
6	4984.000	52.0	33.9	12.1	39.8	58.2	80.0	21.8	100	359
7	5764.000	44.8	34.1	12.9	40.1	51.7	80.0	28.3	200	306

EUT Configuration: *EUT 2*

Above 1 000 MHz (Average Measurement )

Operating mode: G(LAN Scan)

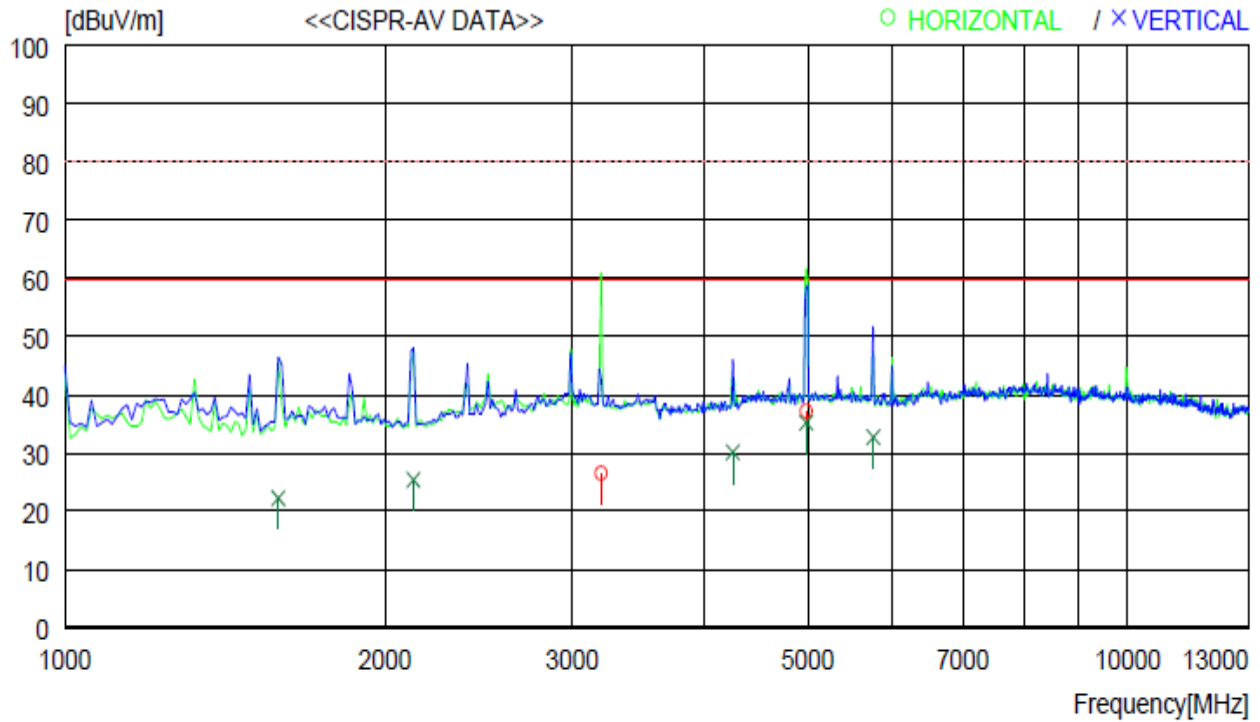

No.	FREQ [MHz]	READING CAV [dBuV]	ANT FACTOR [dB]	LOSS [dB]	GAIN [dB]	RESULT [dBuV/m]	LIMIT [dBuV/m]	MARGIN [dB]	ANTENNA [cm]	TABLE [DEG]
----- Horizontal -----										
1	3196.000	26.0	30.8	9.7	40.0	26.5	60.0	33.5	200	359
2	4984.000	31.0	33.9	12.1	39.8	37.2	60.0	22.8	100	83
----- Vertical -----										
3	1588.000	29.5	26.0	6.6	39.9	22.2	60.0	37.8	300	250
4	2128.000	29.5	28.3	7.5	39.9	25.4	60.0	34.6	100	349
5	4252.000	26.2	32.9	11.0	40.0	30.1	60.0	29.9	300	359
6	4984.000	29.0	33.9	12.1	39.8	35.2	60.0	24.8	100	359
7	5764.000	25.8	34.1	12.9	40.1	32.7	60.0	27.3	200	306

EUT Configuration: *EUT 3*

30 MHz ~ 1 000 MHz

Operating mode: E(USB Memory Stick Print)

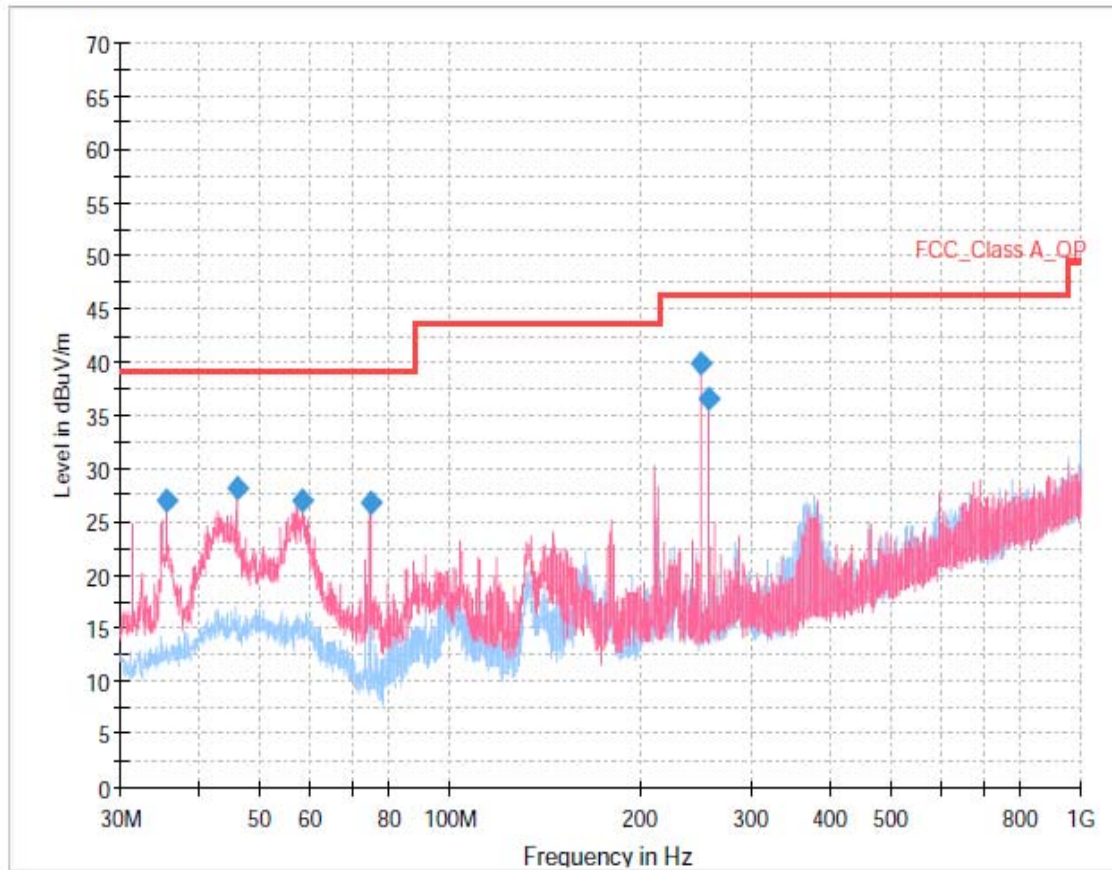

### Final Result

Frequency (MHz)	MaxPeak (dBuV/m)	Limit (dBuV/m)	Margin (dB)	Meas. Time (ms)	Band width (kHz)	Height (cm)	Pol	Azimuth (deg)	Sig Path (dB)	Preamp (dB)	Trd Corr. (dB/m)	Raw Rec (dBuV)
35.50	26.9	39.1	12.2	2.5	120	100.0	V	234	6.7	-32.7	11.3	41.6
45.90	28.1	39.1	11.0	2.5	120	100.0	V	115	6.8	-32.7	14.2	39.8
58.40	26.9	39.1	12.1	2.5	120	300.0	V	276	6.9	-32.7	13.2	39.5
74.67	26.9	39.1	12.2	2.5	120	200.0	V	0	7.1	-32.7	8.4	44.1
249.11	39.9	46.4	6.5	2.5	120	100.0	V	100	8.3	-32.6	12.4	51.8
256.82	36.6	46.4	9.8	2.5	120	100.0	V	100	8.3	-32.6	12.6	48.4

**NOTE** : Quasi Peaks are not measured because Peak Data meet Quasi-Peak limit.

EUT Configuration: **EUT 3**

Above 1 000 MHz (Peak Measurement)

Operating mode: E(USB Memory Stick Print)

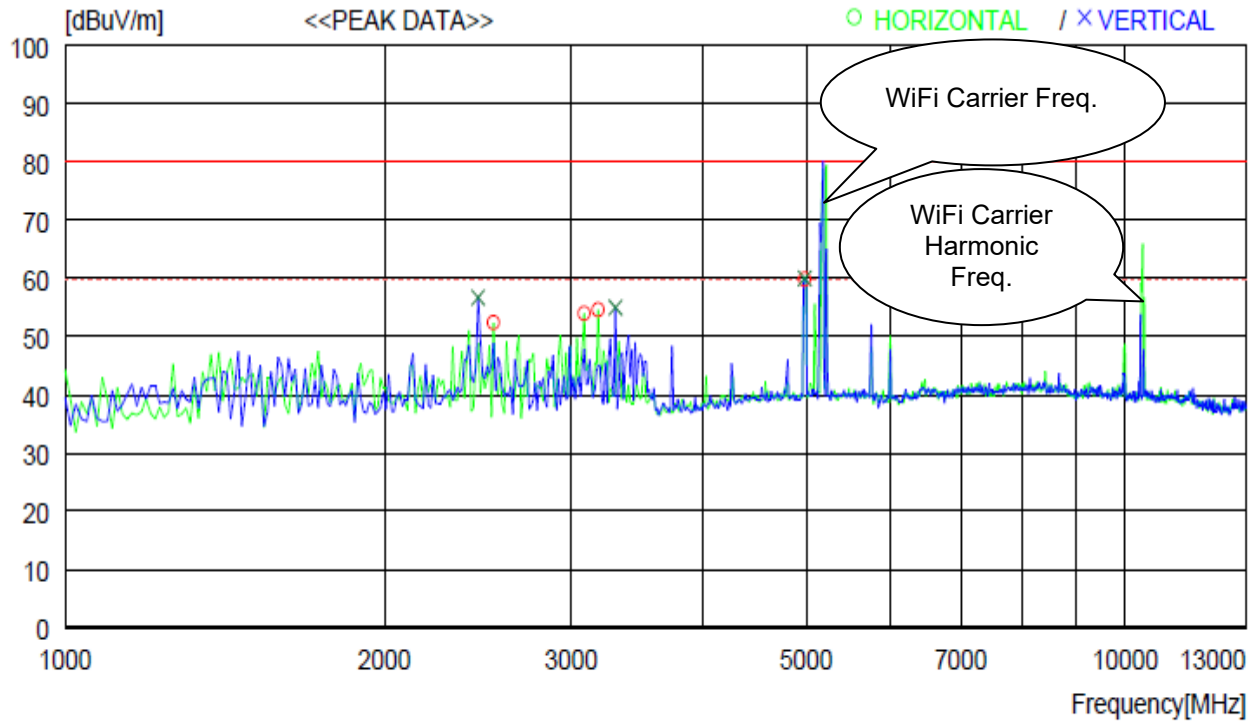

No.	FREQ [MHz]	READING [dBuV]	ANT PEAK FACTOR [dB]	LOSS [dB]	GAIN [dB]	RESULT [dBuV/m]	LIMIT [dBuV/m]	MARGIN [dB]	ANTENNA [cm]	TABLE [DEG]
----- Horizontal -----										
1	2536.000	54.9	28.8	8.5	39.8	52.4	80.0	27.6	300	359
2	3088.000	53.7	30.6	9.6	39.9	54.0	80.0	26	154	320
3	3184.000	54.1	30.8	9.7	40.0	54.6	80.0	25.4	300	219
4	4984.000	53.7	33.9	12.1	39.8	59.9	80.0	20.1	100	46
----- Vertical -----										
5	2452.000	59.3	28.7	8.5	39.8	56.7	80.0	23.3	100	168
6	3304.000	54.1	31.1	9.8	40.0	55.0	80.0	25	200	359
7	4984.000	53.8	33.9	12.1	39.8	60.0	80.0	20	100	0

EUT Configuration: *EUT 3*

Above 1 000 MHz (Average Measurement )

Operating mode: E(USB Memory Stick Print)

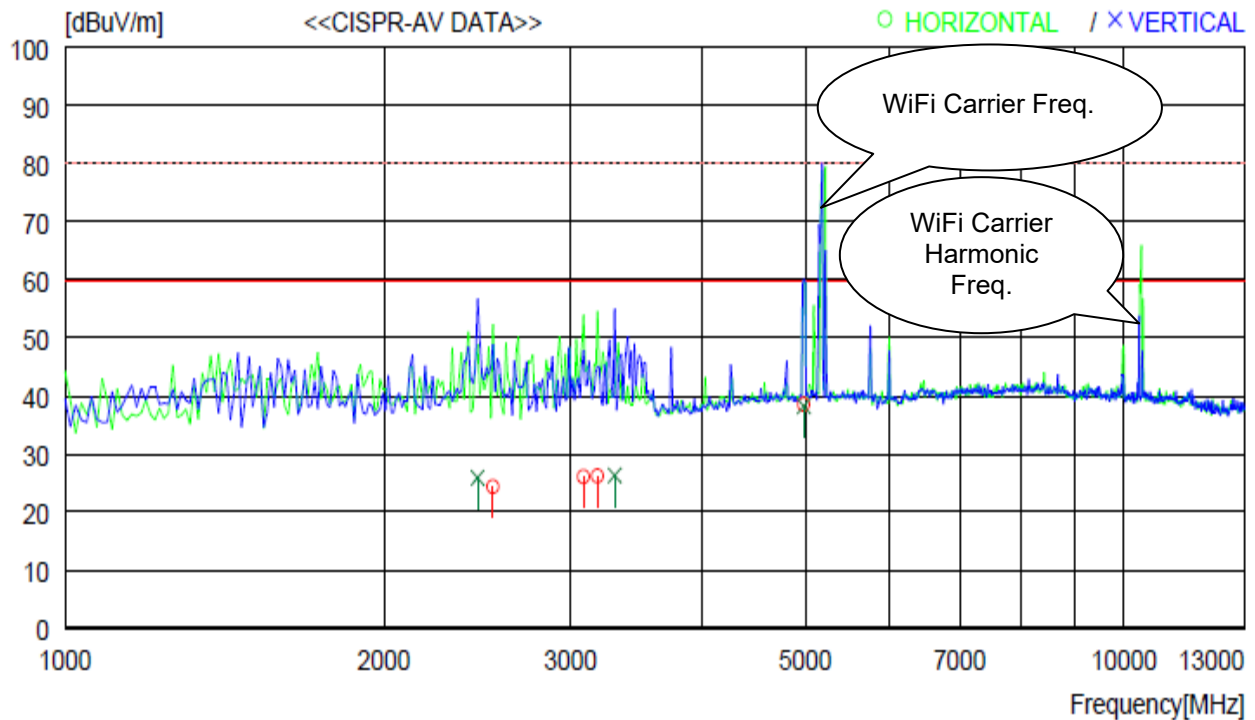

No.	FREQ [MHz]	READING CAV [dBuV]	ANT FACTOR [dB]	LOSS [dB]	GAIN [dB]	RESULT [dBuV/m]	LIMIT [dBuV/m]	MARGIN [dB]	ANTENNA [cm]	TABLE [DEG]
----- Horizontal -----										
1	2536.000	26.9	28.8	8.5	39.8	24.4	60.0	35.6	300	359
2	3088.000	25.8	30.6	9.6	39.9	26.1	60.0	33.9	154	320
3	3184.000	25.7	30.8	9.7	40.0	26.2	60.0	33.8	300	219
4	4984.000	32.3	33.9	12.1	39.8	38.5	60.0	21.5	100	46
----- Vertical -----										
5	2452.000	28.5	28.7	8.5	39.8	25.9	60.0	34.1	100	168
6	3304.000	25.4	31.1	9.8	40.0	26.3	60.0	33.7	200	359
7	4984.000	32.0	33.9	12.1	39.8	38.2	60.0	21.8	100	0

EUT Configuration: *EUT 3*

30 MHz ~ 1 000 MHz

Operating mode: I(WiFi Scan (5 G))

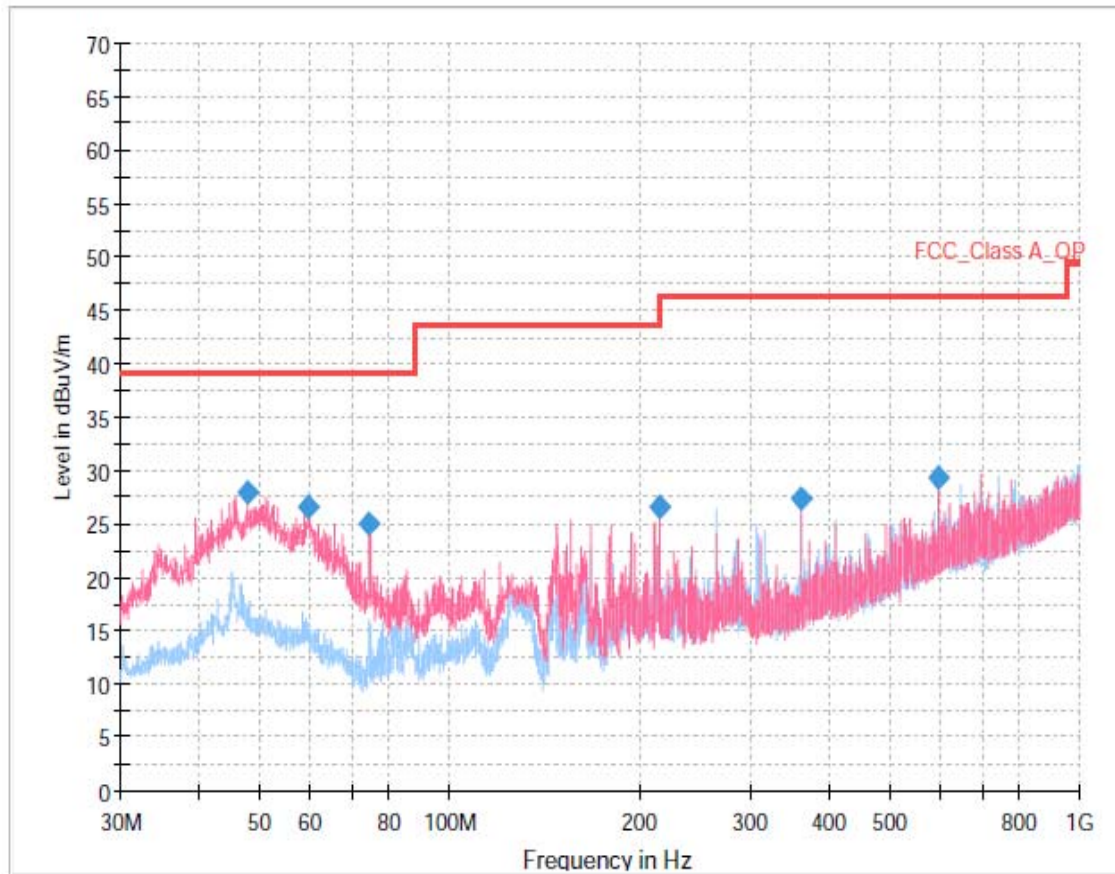

### Final Result

Frequency (MHz)	MaxPeak (dBuV/m)	Limit (dBuV/m)	Margin (dB)	Meas. Time (ms)	Bandwidth (kHz)	Height (cm)	Pol	Azimuth (deg)	Sig Path (dB)	Preamp (dB)	Trd Corr. (dB/m)	Raw Rec (dBuV)
47.73	28.0	39.1	11.0	2.5	120	300.0	V	0	6.8	-32.7	14.3	39.6
59.69	26.7	39.1	12.4	2.5	120	100.0	V	333	6.9	-32.7	13.0	39.4
74.46	25.1	39.1	14.0	2.5	120	300.0	V	0	7.1	-32.7	8.5	42.3
215.97	26.6	43.5	17.0	2.5	120	400.0	H	204	8.1	-32.6	11.6	39.5
360.02	27.3	46.4	19.1	2.5	120	100.0	V	55	8.8	-32.7	14.7	36.5
597.45	29.4	46.4	17.0	2.5	120	200.0	H	173	9.8	-33.0	19.4	33.2

**NOTE** : Quasi Peaks are not measured because Peak Data meet Quasi-Peak limit.



EUT Configuration: **EUT 3**

Above 1 000 MHz (Peak Measurement)

Operating mode: I(WiFi Scan (5 G))

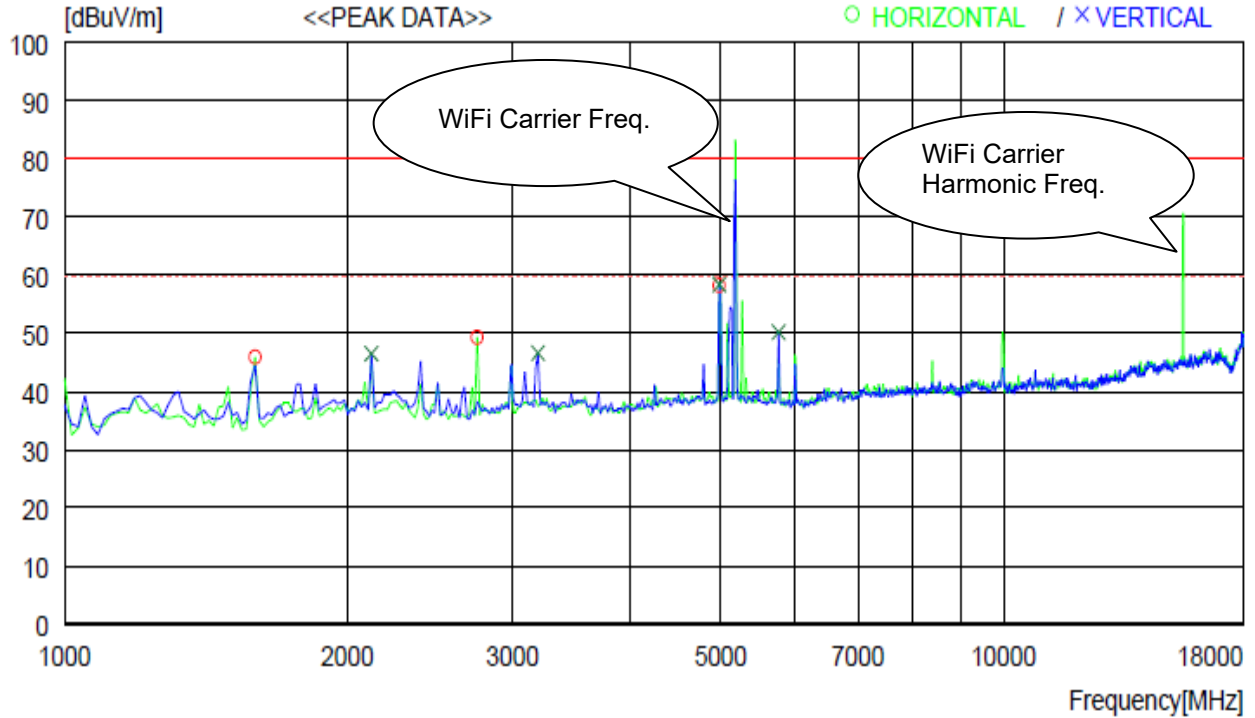

No.	FREQ [MHz]	READING [dBuV]	ANT PEAK FACTOR [dB]	LOSS [dB]	GAIN [dB]	RESULT [dBuV/m]	LIMIT [dBuV/m]	MARGIN [dB]	ANTENNA [cm]	TABLE [DEG]
----- Horizontal -----										
1	1595.000	57.8	26.0	2.0	39.9	45.9	80.0	34.1	300	305
2	2751.000	56.8	29.6	2.7	39.8	49.3	80.0	30.7	300	2
3	4978.000	60.4	33.8	3.8	39.8	58.2	80.0	21.8	300	42
----- Vertical -----										
4	2122.000	55.7	28.3	2.4	39.9	46.5	80.0	33.5	100	0
5	3193.000	52.8	30.8	3.0	40.0	46.6	80.0	33.4	300	0
6	4978.000	60.6	33.8	3.8	39.8	58.4	80.0	21.6	200	51
7	5760.000	52.2	34.1	4.0	40.1	50.2	80.0	29.8	200	359

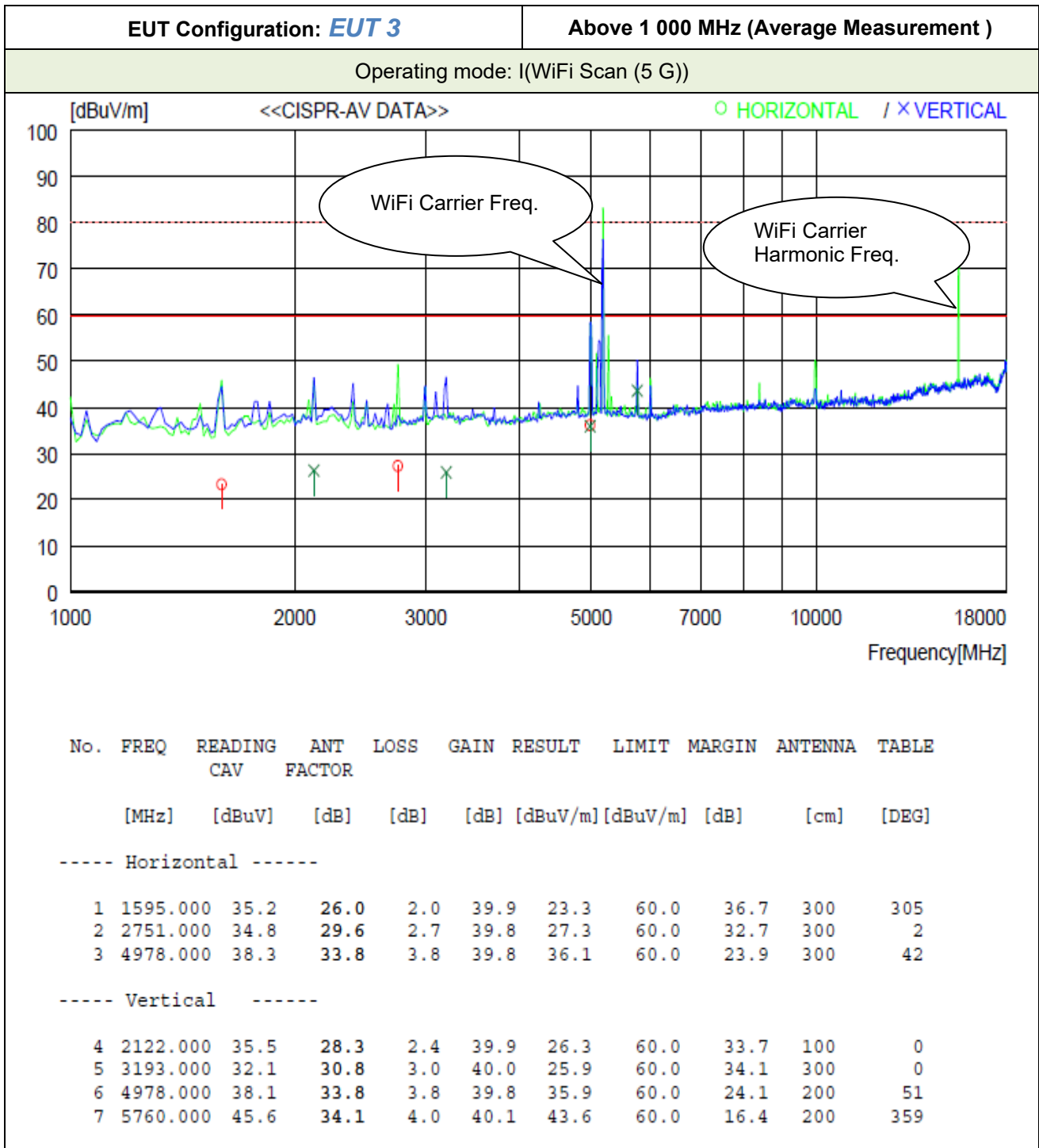

Remark. No emissions were detected above 18 GHz.