

## TEST REPORT

**Report No.: 21050717HKG-002**

BBPOS International Limited

Application For Certification  
(Original Grant)

**FCC ID: 2AB7X-CHB2B**

Transceiver

**Prepared and Checked by:**

**Approved by:**

Signed On File  
Wong Cheuk Ho, Herbert  
Lead Engineer

---

Wong Kwok Yeung, Kenneth  
Senior Lead Engineer  
Date: June 16, 2021

---

Intertek's standard Terms and Conditions can be obtained at our website <http://www.intertek.com/terms/>.

The test report only allows to be revised within the retention period unless further standard or the requirement was noticed.

This report is for the exclusive use of Intertek's Client and is provided pursuant to the agreement between Intertek and its Client. Intertek's responsibility and liability are limited to the terms and conditions of the agreement. Intertek assumes no liability to any party, other than to the Client in accordance with the agreement, for any loss, expense or damage occasioned by the use of this report. Only the Client is authorized to permit copying or distribution of this report and then only in its entirety. Any use of the Intertek name or one of its marks for the sale or advertisement of the tested material, product or service must first be approved in writing by Intertek. The observations and test results in this report are relevant only to the sample tested. This report by itself does not imply that the material, product, or service is or has ever been under an Intertek certification program.

© 2017 Intertek

## TEST REPORT

### GENERAL INFORMATION

<b>Grantee:</b>	BBPOS International Limited
<b>Grantee Address:</b>	Suite 1903-04, 19/F., Tower 2, Nina Tower, No. 8 Yeung Uk Road, Tsuen Wan, N.T., Hong Kong.
<b>Contact Person:</b>	Adrian Kwan
<b>Tel:</b>	+852 3158 2585
<b>Fax:</b>	+852 3158 2586
<b>e-mail:</b>	Adrian.kwan@bbpos.com
<b>Manufacturer:</b>	BBPOS International Limited
<b>Manufacturer Address:</b>	Suite 1903-04, 19/F., Tower 2, Nina Tower, No. 8 Yeung Uk Road, Tsuen Wan, N.T., Hong Kong.
<b>Brand Name:</b>	Toast
<b>Model :</b>	CHB2B
<b>Type of EUT:</b>	Transceiver
<b>Description of EUT:</b>	Toast Chipper 2X BT
<b>Serial Number:</b>	N/A
<b>FCC ID:</b>	2AB7X-CHB2B
<b>Date of Sample Submitted:</b>	May 12, 2021
<b>Date of Test:</b>	May 12, 2021 to June 08, 2021
<b>Report No.:</b>	21050717HKG-002
<b>Report Date:</b>	June 16, 2021
<b>Environmental Conditions:</b>	Temperature: +10 to 40°C Humidity: 10 to 90%
<b>Conclusion:</b>	Test was conducted by client submitted sample. The submitted sample as received complied with the 47 CFR Part 15 Certification.

## TEST REPORT

### SUMMARY OF TEST RESULT

Test Specification	Reference	Results
Transmitter Field Strength Frequency Stability	15.225	Pass
Radiated Emission Radiated Emission on the Bandedge	15.209	Pass
Radiated Emission in Restricted Bands	15.205	Pass

The equipment under test is found to be complying with the following standards:  
FCC Part 15, October 1, 2019 Edition

- Note:
1. The EUT uses a permanently attached antenna which, in accordance to section 15.203, is considered sufficient to comply with the pervisions of this section.
  2. Pursuant to FCC part 15 Section 15.215(c), the 20 dB bandwidth of the emission was contained within the frequency band designated (mentioned as above) which the EUT operated. The effects, if any, from frequency sweeping, frequency hopping, other modulation techniques and frequency stability over excepted variations in temperature and supply voltage were considered.

**TEST REPORT**

**TABLE OF CONTENTS**

**1.0 GENERAL DESCRIPTION ..... 5**

    1.1 Product Description ..... 5

    1.2 Related Submittal(s) Grants ..... 5

    1.3 Test Methodology ..... 5

    1.4 Test Facility ..... 5

**2.0 SYSTEM TEST CONFIGURATION ..... 6**

    2.1 Justification ..... 6

    2.2 EUT Exercising Software ..... 6

    2.3 Special Accessories ..... 6

    2.4 Measurement Uncertainty ..... 6

    2.5 Support Equipment List and Description ..... 6

**3.0 EMISSION RESULTS ..... 7**

    3.1 Field Strength Calculation ..... 7

    3.2 Radiated Emission Configuration Photograph ..... 8

    3.3 Radiated Emission Data ..... 8

    3.4 Conducted Emission Configuration Photograph ..... 8

    3.5 Conducted Emission Data ..... 8

    3.6 Frequency Stability ..... 12

**4.0 EQUIPMENT PHOTOGRAPHS ..... 13**

**5.0 PRODUCT LABELLING ..... 13**

**6.0 TECHNICAL SPECIFICATIONS ..... 13**

**7.0 INSTRUCTION MANUAL ..... 13**

**8.0 MISCELLANEOUS INFORMATION ..... 14**

    8.1 Measured Bandwidth ..... 14

    8.2 Discussion of Pulse Desensitization ..... 15

    8.3 Calculation of Average Factor ..... 15

    8.4 Emissions Test Procedures ..... 16

**9.0 CONFIDENTIALITY REQUEST ..... 20**

**10.0 EQUIPMENT LIST ..... 20**

## TEST REPORT

### 1.0 GENERAL DESCRIPTION

#### 1.1 Product Description

The Equipment Under Test (EUT) is a Toast Chipper 2X BT which is a POS device (point of sale device). It supports reading magnetic stripe credit card, EMV smart credit card and passive RFID tag credit card. It can be connected to PC via USB port and operated by a corresponding software. The magnetic head is for reading data from credit card tape swiping. The embedded EMV chip interface are used for reading EMV smart credit card data. The EUT contains 13.56MHz NFC tag reader for contactless payment card transaction. The EUT is powered by USB port (5VDC).

Antenna Type: Internal, Integral

For electronic filing, the brief circuit description is saved with filename: descri.pdf.

#### 1.2 Related Submittal(s) Grants

This is a single application for certification of a transceiver.

#### 1.3 Test Methodology

Both AC mains line-conducted and radiated emission measurements were performed according to the procedures in ANSI C63.10 (2013). All radiated measurements were performed in an 3m Chamber. Preliminary scans were performed in the 3m Chamber only to determine worst case modes. All radiated tests were performed at an antenna to EUT distance of 3 meters, unless stated otherwise in the “**Justification Section**” of this Application.

#### 1.4 Test Facility

The 3m Chamber and conducted measurement facility used to collect the radiated data is located at Workshop No. 3, G/F., World-Wide Industrial Centre, 43-47 Shan Mei Street, Fo Tan, Sha Tin, N.T., Hong Kong SAR, China. This test facility and site measurement data have been placed on file with the FCC.

## TEST REPORT

### 2.0 SYSTEM TEST CONFIGURATION

#### 2.1 Justification

The system was configured for testing in a typical fashion (as a customer would normally use it), and in the confines as outlined in ANSI C63.10 (2013).

The device was powered by USB Port of 5VDC.

For maximizing emissions below 30 MHz, the EUT was rotated through 360°, the centre of the loop antenna was placed 1 meter above the ground, and the antenna polarization was changed. For maximizing emission at and above 30 MHz, the EUT was rotated through 360°, the antenna height was varied from 1 meter to 4 meters above the ground plane, and the antenna polarization was changed. This step by step procedure for maximizing emissions led to the data report in Exhibit 3.0.

The rear of unit shall be flushed with the rear of the table.

The equipment under test (EUT) was configured for testing in a typical fashion (as a customer would normally use it). The EUT was mounted to a plastic stand if necessary and placed on the wooden turntable, which enabled the engineer to maximize emissions through its placement in the three orthogonal axes.

#### 2.2 EUT Exercising Software

The EUT exercise program (if any) used during radiated testing was designed to exercise the various system components in a manner similar to a typical use.

#### 2.3 Special Accessories

There are no special accessories necessary for compliance of this product.

#### 2.4 Measurement Uncertainty

Decision Rule for compliance: For FCC/IC standard, the measured value must be within the limits of applicable standard without accounting for the measurement uncertainty. For EN/IEC/HKTA/HKTC standard, conformity rules will be used as per standard directly excepted EN/IEC 61000-3-2, EN/IEC 61000-3-3, HKTA1004, HKCA1008, HKTA1019, HKTA1020, HKTA1041 and HKTA1044. For these excepted or not mentioned standards, Cl 4.2.2 of ILAC-G8:09/2019 decision rules will be reference and guard band will be equal to our measurement uncertainty with 95% confidence level (k=2). In case, the measured value is within guard band region, undetermined decision will be used.

Uncertainty and Compliance - Unless the standard specifically states that measured values are to be extended by the measurement uncertainty in determining compliance, all compliance determinations are based on the actual measured value.

#### 2.5 Support Equipment List and Description

1. LAN cable of 20m long with termination
2. HP Notebook Computer (Adaptor Model: HSTNN-CA15)  
(Provided by Intertek)
3. USB cable of 40cm long (with ferrite)  
(Provided by Applicant)

## TEST REPORT

### 3.0 EMISSION RESULTS

Data is included of the worst-case configuration (the configuration which resulted in the highest emission levels). A sample calculation, configuration photographs and data tables of the emissions are included.

#### 3.1 Field Strength Calculation

The field strength is calculated by adding the Antenna Factor and Cable Factor, and subtracting the Amplifier Gain (if any), Average Factor (optional) from the measured reading. The basic equation with a sample calculation is as follows:

$$FS = RA + AF + CF - AG - AV$$

where FS = Field Strength in dB $\mu$ V/m

RA = Receiver Amplitude (including preamplifier) in dB $\mu$ V

CF = Cable Attenuation Factor in dB

AF = Antenna Factor in dB

AG = Amplifier Gain in dB

AV = Average Factor in dB

In the following table(s), the reading shown on the data table reflects the preamplifier gain. An example for the calculations in the following table is as follows:

$$FS = RR + LF$$

where FS = Field Strength in dB $\mu$ V/m

RR = RA - AG - AV in dB $\mu$ V

LF = CF + AF in dB

Assume a receiver reading of 52.0 dB $\mu$ V is obtained. The antenna factor of 7.4 dB and cable factor of 1.6 dB are added. The amplifier gain of 29 dB and average factor of 5 dB are subtracted, giving a field strength of 27 dB $\mu$ V/m. This value in dB $\mu$ V/m was converted to its corresponding level in  $\mu$ V/m.

$$RA = 52.0 \text{ dB}\mu\text{V/m}$$

$$AF = 7.4 \text{ dB}$$

$$CF = 1.6 \text{ dB}$$

$$AG = 29.0 \text{ dB}$$

$$AV = 5.0 \text{ dB}$$

$$FS = RR + LF$$

$$FS = 18 + 9 = 27 \text{ dB}\mu\text{V/m}$$

$$RR = 18.0 \text{ dB}\mu\text{V}$$

$$LF = 9.0 \text{ dB}$$

$$\text{Level in } \mu\text{V/m} = \text{Common Antilogarithm } [(27 \text{ dB}\mu\text{V/m})/20] = 22.4 \mu\text{V/m}$$

## TEST REPORT

### 3.2 Radiated Emission Configuration Photograph

The worst case in radiated emission was found at 40.682 MHz

For electronic filing, the worst-case radiated emission configuration photographs are saved with filename: radiated photos.pdf.

### 3.3 Radiated Emission Data

The data on the following page lists the significant emission frequencies, the limit and the margin of compliance. Numbers with a minus sign are below the limit.

Judgment: Passed by 1.2 dB

### 3.4 Conducted Emission Configuration Photograph

The worst case in line-conducted emission was found at 13.560 MHz

For electronic filing, the worst-case line-conducted configuration photographs are saved with filename: conducted photo.pdf.

### 3.5 Conducted Emission Data

For electronic filing, the graph and data table of conducted emission is saved with filename: conducted.pdf.

Judgment: Pass by 1.2 dB



**TEST REPORT**

**CONDUCTED EMISSION**

Model: CHB2B

Date of Test: June 08, 2021

Worst-Case Operating Mode: NFC

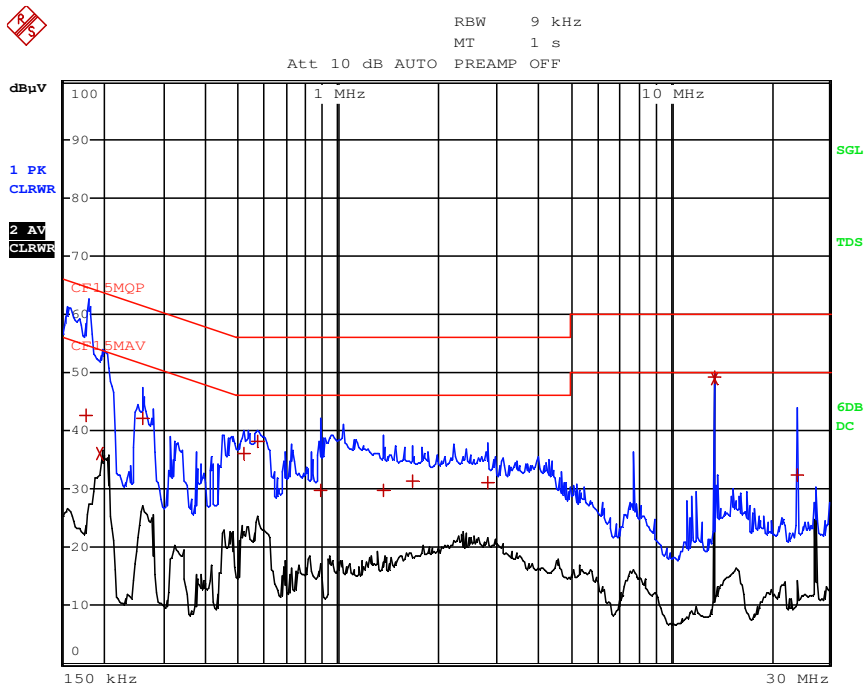

EDIT PEAK LIST (Final Measurement Results)				
TRACE	FREQUENCY	LEVEL dBµV	DELTA	LIMIT dB
Trace1:	CF15MQP			
Trace2:	CF15MAV			
Trace3:	---			
1	Quasi Peak 177 kHz	42.72 L1	-21.90	
2	CISPR Average 195 kHz	36.21 N	-17.61	
1	Quasi Peak 258 kHz	42.07 L1	-19.42	
1	Quasi Peak 519 kHz	36.20 N	-19.79	
1	Quasi Peak 573 kHz	38.30 N	-17.69	
1	Quasi Peak 883.5 kHz	29.67 N	-26.32	
1	Quasi Peak 1.3695 MHz	29.82 N	-26.17	
1	Quasi Peak 1.6845 MHz	31.32 N	-24.67	
1	Quasi Peak 2.805 MHz	31.12 N	-24.87	
1	Quasi Peak 13.56 MHz	49.18 L1	-10.81	
2	CISPR Average 13.56 MHz	48.83 L1	-1.16	
1	Quasi Peak 24 MHz	32.49 N	-27.50	

Note: Measurement Uncertainty is  $\pm 4.2$ dB at a level of confidence of 95%.

**TEST REPORT**

**RADIATED EMISSIONS**

Model: CHB2B

Date of Test: June 08, 2021

Worst-Case Operating Mode: Transmitting

Table 1  
Pursuant to FCC Part 15 Section 15.225 Requirement

Polarization	Frequency (MHz)	Reading (dBμV)	Pre-Amp Gain (dB)	Antenna Factor (dB)	Net at 3m (dBμV/m)	Distance Factor (-dB)	Calculated at 30m (dBμV/m)	Limit at 30m (dBμV/m)	Margin (dB)
O	13.560	57.7	0	10.8	68.5	40.0	28.5	84.0	-55.5
O	27.120	31.1	0	9.5	40.6	40.0	0.6	29.5	-28.9

- NOTES:
1. Quasi-Peak Detector Data unless otherwise stated.
  2. All measurements were made at 3 meters.
  3. Negative sign in the column shows value below limit.
  4. Loop antenna is used for the emissions below 30MHz.
  5. Emission (the row indicated by ***bold italic***) within the restricted band meets the requirement of FCC Part 15 Section 15.205.
  6. Measurement Uncertainty is ±5.3dB at a level of confidence of 95%.

**TEST REPORT**

Model: CHB2B

Date of Test: June 08, 2021

Worst-Case Operating Mode: Transmitting

Table 2  
**Pursuant to FCC Part 15 Section 15.209 Requirement**

Polarization	Frequency (MHz)	Reading (dBμV)	Pre-amp (dB)	Antenna Factor (dB)	Net at 3m (dBμV/m)	Limit at 3m (dBμV/m)	Margin (dB)
V	40.682	44.8	16	10.0	38.8	40.0	-1.2
H	54.250	29.5	16	11.0	24.5	40.0	-15.5
H	67.794	46.2	16	8.0	38.2	40.0	-1.8
H	72.044	37.4	16	7.0	28.4	40.0	-11.6
H	119.454	34.5	16	14.0	32.5	43.5	-11.0
H	404.154	24.6	16	24.0	32.6	46.0	-13.4

- NOTES:
1. Quasi-Peak Detector Data unless otherwise stated.
  2. All measurements were made at 3 meters.
  3. Negative sign in the column shows value below limit.
  4. Horn antenna is used for the emission over 1000MHz.
  5. Emission (the row indicated by ***bold italic***) within the restricted band meets the requirement of FCC Part 15 Section 15.205.
  6. Measurement Uncertainty is ±5.3dB at a level of confidence of 95%.

**TEST REPORT**

3.6 Frequency Stability

**FCC Part 15 Section 15.225**

**Data Table  
Frequency Deviation with Voltage Variation**

Operating frequency		13.560MHz		
Test Voltage (V)	Temperature (°C)	Measured frequency (MHz)	Frequency error (%)	Limit (%)
120	+ 50	13.560714	+0.0053	±0.01
	+ 40	13.560718	+0.0053	±0.01
	+ 30	13.560720	+0.0053	±0.01
	+ 20	13.560722	+0.0053	±0.01
	+ 10	13.560728	+0.0054	±0.01
	0	13.560736	+0.0054	±0.01
	- 10	13.560738	+0.0054	±0.01
	- 20	13.560744	+0.0055	±0.01

Nominal frequency		13.560MHz				
Temperature (°C)	Humidity (%)	Voltage	Frequency (MHz)	Frequency error (ppm)	Limite (ppm)	result
20°C	50%	102	13.560732	54.0	100	Pass
20°C	50%	120	13.560722	53.2	100	Pass
20°C	50%	132	13.560720	53.1	100	Pass
Min -20C	0%	102	13.560752	55.5	100	Pass
Min -20C	0%	120	13.560744	54.6	100	Pass
Min -20C	0%	132	13.560740	54.6	100	Pass
Max 50C	50%	102	13.560718	52.9	100	Pass
Max 50C	50%	120	13.560714	52.7	100	Pass
Max 50C	50%	132	13.560710	52.4	100	Pass

The device is deemed to comply with requirement of FCC 15.225(e).

## TEST REPORT

### 4.0 EQUIPMENT PHOTOGRAPHS

For electronic filing, the photographs are saved with filename: external photos.pdf and internal photos.pdf.

### 5.0 PRODUCT LABELLING

For electronics filing, the FCC ID label artwork and the label location are saved with filename: label.pdf.

### 6.0 TECHNICAL SPECIFICATIONS

For electronic filing, the block diagram and schematic of the tested EUT are saved with filename: block.pdf and circuit.pdf respectively.

### 7.0 INSTRUCTION MANUAL

For electronic filing, a preliminary copy of the Instruction Manual is saved with filename: manual.pdf.

This manual will be provided to the end-user with each unit sold/leased in the United States.

**TEST REPORT**

**8.0 MISCELLANEOUS INFORMATION**

The miscellaneous information includes details of the test procedure and measured bandwidth such as pulse desensitization and averaging factor (calculation and timing diagram).

**8.1 Measured Bandwidth**

The plot saved in bw.pdf which shows the fundamental emission is confined in the specified band. The emission of the fundamental is 28.5 dBμV/m and it is below the limit of 50.5 dBμV/m in the range of (13.410-13.553MHz) and (13.710-14.010MHz) and the limit of 40.5 dBμV/m in the frequency range of (13.110-14.410MHz) and (13.710-14.010MHz). In the frequency range from 13.110-14.010MHz, we can not find any emission higher than the fundamental emission. Therefore they meet the requirement of Section 15.225(a), (b), (c), & (d).

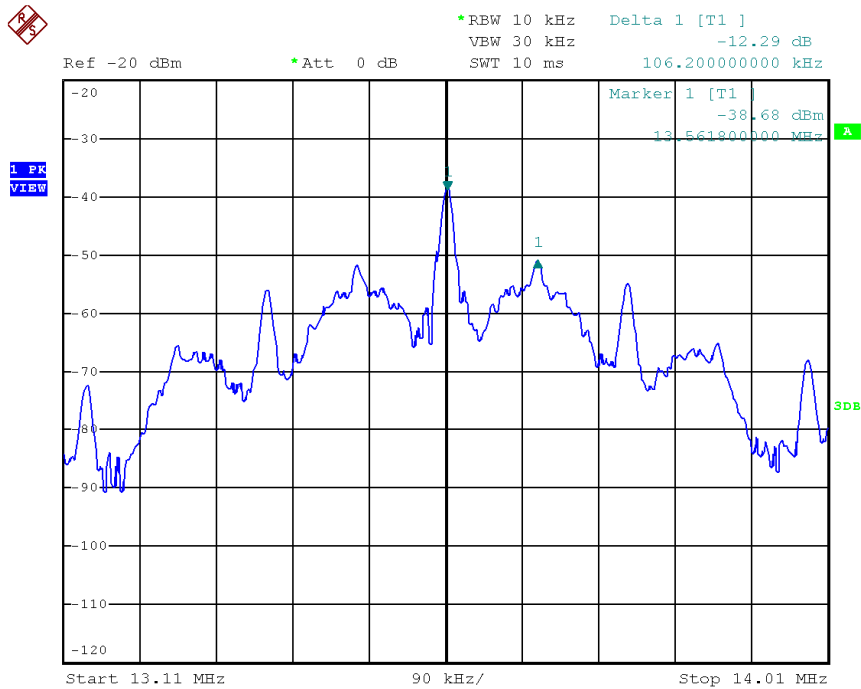

## TEST REPORT

### 8.2 Discussion of Pulse Desensitization

Pulse desensitivity is not applicable for this device. Since the transmitter transmits the RF signal continuously.

### 8.3 Calculation of Average Factor

N/A

## TEST REPORT

### 8.4 Emissions Test Procedures

The following is a description of the test procedure used by Intertek Testing Services Hong Kong Ltd. in the measurements of transmitter operating under the Part 15, Subpart C rules.

The transmitting equipment under test (EUT) is placed on a wooden turntable which is four feet in diameter and approximately 0.8m in height above the ground plane for emission measurement at or below 1GHz and 1.5m in height above the ground plane for emission measurement above 1GHz. During the radiated emissions test, the turntable is rotated and any cables leaving the EUT are manipulated to find the configuration resulting in maximum emissions. The EUT is adjusted through all three orthogonal axis to obtain maximum emission levels. The antenna height and polarization are also varied during the testing to search for maximum signal levels. The height of the antenna is varied from one to four meters.

Detector function for radiated emissions is in peak mode. Average readings, when required, are taken by measuring the duty cycle of the equipment under test and subtracting the corresponding amount in dB from the measured peak readings. A detailed description for the calculation of the average factor can be found in Exhibit 8.3.

The frequency range scanned is from the lowest radio frequency signal generated in the device which is greater than 9 kHz to the tenth harmonic of the highest fundamental frequency or 40 GHz, whichever is lower. For line conducted emissions, the range scanned is 150 kHz to 30 MHz.



## TEST REPORT

### 8.4 Emissions Test Procedures (cont'd)

The EUT is warmed up for 15 minutes prior to the test.

AC power to the unit is varied from 85% to 115% nominal and variation in the fundamental emission field strength is recorded. If battery powered, a new, fully charged battery is used.

Conducted measurements were made as described in ANSI C63.10 (2013).

The IF bandwidth used for measurement of radiated signal strength was 100 kHz or greater when frequency is below 1000 MHz. Where pulsed transmissions of short enough pulse duration warrant, a greater bandwidth is selected according to the recommendations of Hewlett Packard Application Note 150-2. A discussion of whether pulse desensitivity is applicable to this unit is included in this report (See Exhibit 8.1). Above 1000 MHz, a resolution bandwidth of 3 MHz is used.

Transmitter measurements are normally conducted at a measurement distance of three meters. However, to assure low enough noise floor in the forbidden bands and above 1 GHz, signals are acquired at a distance of one meter or less. All measurements are extrapolated to three meters using inverse scaling, unless otherwise reported. Measurements taken at a closer distance are so marked.

**TEST REPORT**

8.4.1 Radiated Emission Test Setup

The figure below shows the test setup, which is utilized to make these measurements.

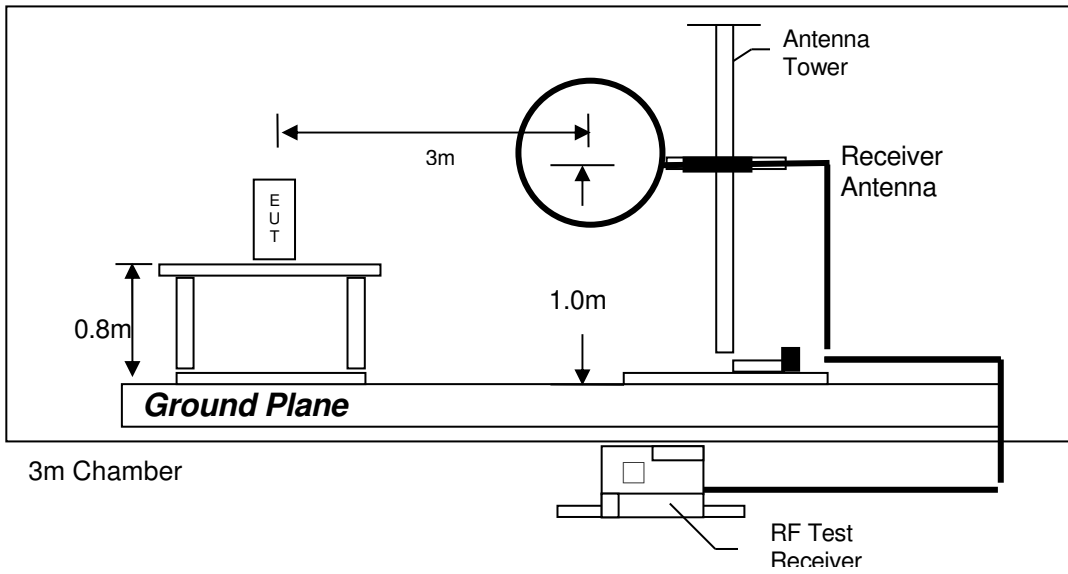

Test setup of radiated emissions up to 30MHz

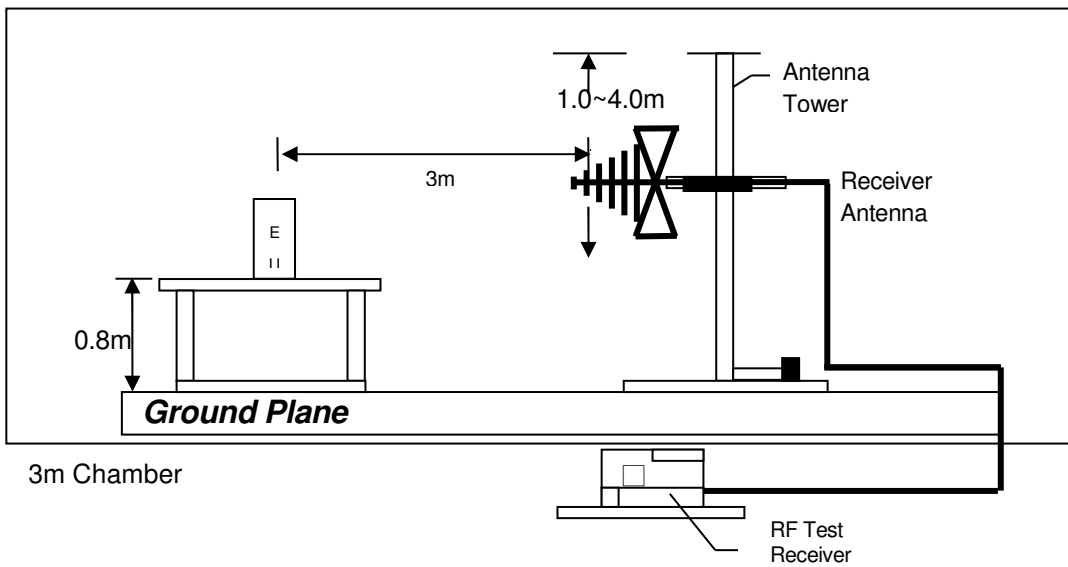

Test setup of radiated emissions above 1GHz

## TEST REPORT

### 8.4.2 Conducted Emission Test Procedures

For tabletop equipment, the EUT along with its peripherals were placed on a 1.0m(W)×1.5m(L) and 0.8m in height wooden table. For floor-standing equipment, the EUT and all cables were insulated, if required, from the ground plane by up to 12 mm of insulating material. The EUT was adjusted to maintain a 0.4 meter space from a vertical reference plane. The EUT was connected to power mains through a line impedance stabilization network (LISN), which provided 50 ohm coupling impedance for measuring instrument and the chassis ground was bounded to the horizontal ground plane of shielded room. The excess power cable between the EUT and the LISN was bundled.

All connecting cables of EUT and peripherals were moved to find the maximum emission.

### 8.4.3 Conducted Emission Test Setup

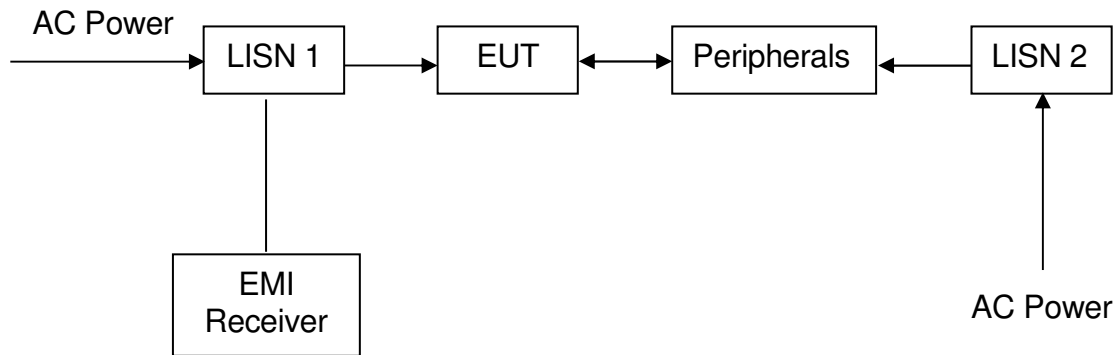

## TEST REPORT

### 9.0 CONFIDENTIALITY REQUEST

For electronic filing, a preliminary copy of the confidentiality request is saved with filename: request.pdf.

### 10.0 EQUIPMENT LIST

#### 1) Radiated Emissions Test

Equipment	EMI Test Receiver (9kHz to 26.5GHz)	Spectrum Analyzer	Biconical Antenna (20MHz to 200MHz)
Registration No.	EW-3156	EW-2466	EW-2512
Manufacturer	ROHDESCHWARZ	ROHDESCHWARZ	EMCO
Model No.	ESR26	FSP30	3104C
Calibration Date	January 25, 2021	September 05, 2020	June 03, 2020
Calibration Due Date	January 25, 2022	September 05, 2021	December 03, 2021

Equipment	Log Periodic Antenna	Double Ridged Guide Antenna	RF Cable 14m (1GHz to 26.5GHz)
Registration No.	EW-0447	EW-1133	EW-2781
Manufacturer	EMCO	EMCO	GREATBILLION
Model No.	3146	3115	SMA m/SHF5MPU /SMA m ra14m,26G
Calibration Date	September 25, 2019	June 03, 2021	November 24, 2020
Calibration Due Date	June 25, 2021	June 03, 2022	November 24, 2021

Equipment	RF Preamplifier (9kHz to 6000MHz)	Active Loop H-field (9kHz to 30MHz)	14m Double Shield RF Cable (20MHz to 6GHz)
Registration No.	EW-3006b	EW-2313	EW-2074
Manufacturer	SCHWARZBECK	ELECTROMETRI	RADIALL
Model No.	BBV9718	EM-6876	N(m)-RG142-BNC(m) L=14M
Calibration Date	November 25, 2019	December 17, 2019	August 29, 2020
Calibration Due Date	June 25, 2021	June 17, 2021	August 29, 2021

**TEST REPORT**

2) Conducted Emissions Test

Equipment	RF Cable 240cm (RG142) (9kHz to 30MHz)	Artificial Mains Network	EMI Test Receiver)
Registration No.	EW-2454	EW-2501	EW-2500
Manufacturer	RADIALL	ROHDESCHWARZ	ROHDESCHWARZ
Model No.	Bnc m st / 142 / bnc mra 240cm	ENV-216	ESCI
Calibration Date	November 10, 2020	September 11, 2020	March 29, 2021
Calibration Due Date	November 10, 2021	September 11, 2021	March 29, 2022

3) Bandedge Measurement

Equipment	Spectrum Analyzer	RF Cable 240cm (RG142) (9kHz to 30MHz)
Registration No.	EW-2466	EW-2454
Manufacturer	ROHDESCHWARZ	RADIALL
Model No.	FSP30	Bnc m st / 142 / bnc mra 240cm
Calibration Date	September 05, 2020	November 10, 2020
Calibration Due Date	September 05, 2021	November 10, 2021

## TEST REPORT

### 4) Frequency Error Measurement

Equipment	RF Cable 240cm (RG142) (9kHz to 30MHz)	Spectrum Analyzer	Temperature & Humidity Chamber
Registration No.	EW-2454	EW-2466	EW-1580
Manufacturer	RADIALL	ROHDESCHWARZ	ESPEC
Model No.	bnc m st / 142 /bnc m ra 240cm	FSP30	PL-4KP
Calibration Date	November 10, 2020	September 05, 2020	December 04, 2020
Calibration Due Date	November 10, 2021	September 05, 2021	September 30, 2021

**END OF TEST REPORT**