

TEST REPORT

Report No.: 20020183HKG-002R1

BBPOS International Limited

Application For Certification
(Original Grant)

FCC ID: 2AB7X-CHB24

Transceiver

This report supersedes previous report with report number 20020183HKG-002 dated March 04, 2020.
Please refer ICT-S20-0003 Letter issued on March 09, 2020 for amendment/ supersede notification.

Prepared and Checked by:

Approved by:

Signed On File
Wong Cheuk Ho, Herbert
Lead Engineer

Wong Kwok Yeung, Kenneth
Senior Lead Engineer
Date: March 09, 2020

Intertek's standard Terms and Conditions can be obtained at our website <http://www.intertek.com/terms/>.

The test report only allows to be revised within the retention period unless further standard or the requirement was noticed.

This report is for the exclusive use of Intertek's Client and is provided pursuant to the agreement between Intertek and its Client. Intertek's responsibility and liability are limited to the terms and conditions of the agreement. Intertek assumes no liability to any party, other than to the Client in accordance with the agreement, for any loss, expense or damage occasioned by the use of this report. Only the Client is authorized to permit copying or distribution of this report and then only in its entirety. Any use of the Intertek name or one of its marks for the sale or advertisement of the tested material, product or service must first be approved in writing by Intertek. The observations and test results in this report are relevant only to the sample tested. This report by itself does not imply that the material, product, or service is or has ever been under an Intertek certification program.

© 2017 Intertek

TEST REPORT

GENERAL INFORMATION

Grantee:	BBPOS International Limited
Grantee Address:	Suite 1903-04, 19/F., Tower 2, Nina Tower, No. 8 Yeung Uk Road, Tsuen Wan, N.T., Hong Kong
Contact Person:	Adrian Kwan
Tel:	(852) 31582585
Fax:	N/A
e-mail:	N/A
Brand Name:	Toast
Model:	CHB24
Type of EUT:	Transceiver
Description of EUT:	Toast Chipper 2X BT
Serial Number:	N/A
FCC ID:	2AB7X-CHB24
Date of Sample Submitted:	February 18, 2020
Date of Test:	February 18, 2020 to February 26, 2020
Report No.:	20020183HKG-002R1
Report Date:	March 09, 2020
Environmental Conditions:	Temperature: +10 to 40°C Humidity: 10 to 90%
Conclusion:	Test was conducted by client submitted sample. The submitted sample as received complied with the 47 CFR Part 15.

TEST REPORT

SUMMARY OF TEST RESULT

Test Specification	Reference	Results
Transmitter Field Strength Frequency Stability	15.225	Pass
Radiated Emission Radiated Emission on the Bandedge	15.209	Pass
Radiated Emission in Restricted Bands	15.205	Pass

The equipment under test is found to be complying with the following standards:
FCC Part 15, October 1, 2018 Edition

- Note:
1. The EUT uses a permanently attached antenna which, in accordance to section 15.203, is considered sufficient to comply with the provisions of this section.
 2. Pursuant to FCC part 15 Section 15.215(c), the 20 dB bandwidth of the emission was contained within the frequency band designated (mentioned as above) which the EUT operated. The effects, if any, from frequency sweeping, frequency hopping, other modulation techniques and frequency stability over excepted variations in temperature and supply voltage were considered.

TEST REPORT

TABLE OF CONTENTS

1.0	GENERAL DESCRIPTION	5
1.1	Product Description	5
1.2	Related Submittal(s) Grants	5
1.3	Test Methodology.....	5
1.4	Test Facility	5
2.0	SYSTEM TEST CONFIGURATION.....	6
2.1	Justification	6
2.2	EUT Exercising Software.....	6
2.3	Special Accessories	6
2.4	Measurement Uncertainty.....	6
2.5	Support Equipment List and Description.....	6
3.0	EMISSION RESULTS.....	7
3.1	Field Strength Calculation	7
3.2	Radiated Emission Configuration Photograph.....	8
3.3	Radiated Emission Data	8
3.4	Conducted Emission Configuration Photograph	8
3.5	Conducted Emission Data	8
3.6	Frequency Stability	12
4.0	EQUIPMENT PHOTOGRAPHS	13
5.0	PRODUCT LABELLING.....	13
6.0	TECHNICAL SPECIFICATIONS	13
7.0	INSTRUCTION MANUAL.....	13
8.0	MISCELLANEOUS INFORMATION	14
8.1	Measured Bandwidth	14
8.2	Discussion of Pulse Desensitization.....	15
8.3	Calculation of Average Factor	15
8.4	Emissions Test Procedures.....	16
9.0	CONFIDENTIALITY REQUEST	20
10.0	EQUIPMENT LIST.....	20

TEST REPORT

1.0 GENERAL DESCRIPTION

1.1 Product Description

The Equipment Under Test (EUT) is a Toast Chipper 2X BT which is a POS device (point of sale device). It supports reading EMV smart credit card and passive RFID tag credit card. It can be connected to PC via USB port and operated by a corresponding software. The embedded EMV chip interface are used for reading EMV smart credit card data. The EUT contains 13.56MHz NFC tag reader for contactless payment card transaction. The EUT is powered by USB port (5VDC).

Antenna Type: Internal, Integral

For electronic filing, the brief circuit description is saved with filename: descri.pdf.

1.2 Related Submittal(s) Grants

This is a single application for certification of a transceiver.

1.3 Test Methodology

Both AC mains line-conducted and radiated emission measurements were performed according to the procedures in ANSI C63.10 (2013). All radiated measurements were performed in an 3m Chamber. Preliminary scans were performed in the 3m Chamber only to determine worst case modes. All radiated tests were performed at an antenna to EUT distance of 3 meters, unless stated otherwise in the “**Justification Section**” of this Application.

1.4 Test Facility

The 3m Chamber and conducted measurement facility used to collect the radiated data is located at Workshop No. 3, G/F., World-Wide Industrial Centre, 43-47 Shan Mei Street, Fo Tan, Sha Tin, N.T., Hong Kong SAR, China. This test facility and site measurement data have been placed on file with the FCC.

TEST REPORT

2.0 SYSTEM TEST CONFIGURATION

2.1 Justification

The system was configured for testing in a typical fashion (as a customer would normally use it), and in the confines as outlined in ANSI C63.10 (2013).

The device was powered by USB Port (5VDC).

For maximizing emissions below 30 MHz, the EUT was rotated through 360°, the centre of the loop antenna was placed 1 meter above the ground, and the antenna polarization was changed. For maximizing emission at and above 30 MHz, the EUT was rotated through 360°, the antenna height was varied from 1 meter to 4 meters above the ground plane, and the antenna polarization was changed. This step by step procedure for maximizing emissions led to the data report in Exhibit 3.0.

The rear of unit shall be flushed with the rear of the table.

The equipment under test (EUT) was configured for testing in a typical fashion (as a customer would normally use it). The EUT was mounted to a plastic stand if necessary and placed on the wooden turntable, which enabled the engineer to maximize emissions through its placement in the three orthogonal axes.

2.2 EUT Exercising Software

The EUT exercise program (if any) used during radiated testing was designed to exercise the various system components in a manner similar to a typical use.

2.3 Special Accessories

There are no special accessories necessary for compliance of this product.

2.4 Measurement Uncertainty

When determining of the test conclusion, the Measurement Uncertainty of test has been considered.

Uncertainty and Compliance - Unless the standard specifically states that measured values are to be extended by the measurement uncertainty in determining compliance, all compliance determinations are based on the actual measured value.

2.5 Support Equipment List and Description

1. HP Notebook (Adaptor Model: HSTNN-CA15)
2. 1 x LAN cable with length of 2.0m long with termination
(Provided by Intertek)
3. 1 x USB cable with length of 0.9m long with ferrite
(Provided by applicant)

TEST REPORT

3.0 EMISSION RESULTS

Data is included of the worst case configuration (the configuration which resulted in the highest emission levels). A sample calculation, configuration photographs and data tables of the emissions are included.

3.1 Field Strength Calculation

The field strength is calculated by adding the Antenna Factor and Cable Factor, and subtracting the Amplifier Gain (if any), Average Factor (optional) from the measured reading. The basic equation with a sample calculation is as follows:

$$FS = RA + AF + CF - AG - AV$$

where FS = Field Strength in dB μ V/m

RA = Receiver Amplitude (including preamplifier) in dB μ V

CF = Cable Attenuation Factor in dB

AF = Antenna Factor in dB

AG = Amplifier Gain in dB

AV = Average Factor in dB

In the following table(s), the reading shown on the data table reflects the preamplifier gain. An example for the calculations in the following table is as follows:

$$FS = RR + LF$$

where FS = Field Strength in dB μ V/m

RR = RA - AG - AV in dB μ V

LF = CF + AF in dB

Assume a receiver reading of 52.0 dB μ V is obtained. The antenna factor of 7.4 dB and cable factor of 1.6 dB are added. The amplifier gain of 29 dB and average factor of 5 dB are subtracted, giving a field strength of 32 dB μ V/m. This value in dB μ V/m was converted to its corresponding level in μ V/m.

$$RA = 52.0 \text{ dB}\mu\text{V/m}$$

$$AF = 7.4 \text{ dB}$$

$$CF = 1.6 \text{ dB}$$

$$AG = 29.0 \text{ dB}$$

$$AV = 5.0 \text{ dB}$$

$$FS = RR + LF$$

$$FS = 18 + 9 = 27 \text{ dB}\mu\text{V/m}$$

$$RR = 18.0 \text{ dB}\mu\text{V}$$

$$LF = 9.0 \text{ dB}$$

$$\text{Level in } \mu\text{V/m} = \text{Common Antilogarithm } [(27 \text{ dB}\mu\text{V/m})/20] = 22.4 \mu\text{V/m}$$

TEST REPORT

3.2 Radiated Emission Configuration Photograph

The worst case in radiated emission was found at 67.804 MHz

For electronic filing, the worst case radiated emission configuration photographs are saved with filename: radiated photos.pdf.

3.3 Radiated Emission Data

The data on the following page lists the significant emission frequencies, the limit and the margin of compliance. Numbers with a minus sign are below the limit.

Judgment: Passed by 1.2 dB

3.4 Conducted Emission Configuration Photograph

The worst case in line-conducted emission was found at 13.560 MHz

For electronic filing, the worst case line-conducted configuration photographs are saved with filename: conducted photo.pdf.

3.5 Conducted Emission Data

For electronic filing, the graph and data table of conducted emission is saved with filename: conducted.pdf.

Judgment: Pass by 6.2 dB

TEST REPORT

CONDUCTED EMISSION

Model: CHB24

Date of Test: February 26, 2020

Worst-Case Operating Mode: NFC Operating

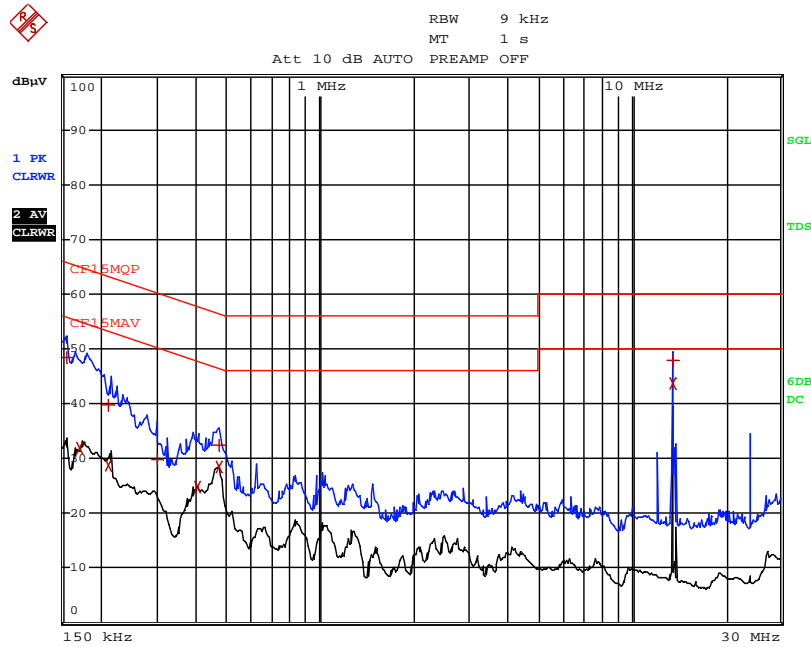

EDIT PEAK LIST (Final Measurement Results)				
Trace1:		CF15MQP		
Trace2:		CF15MAV		
Trace3:		---		
TRACE	FREQUENCY	LEVEL dBµV		DELTA LIMIT dB
1	Quasi Peak 154.5 kHz	48.47	L1	-17.27
2	CISPR Average 172.5 kHz	32.01	L1	-22.82
1	Quasi Peak 213 kHz	39.86	L1	-23.21
2	CISPR Average 213 kHz	28.81	L1	-24.27
1	Quasi Peak 298.5 kHz	29.81	L1	-30.47
2	CISPR Average 402 kHz	24.77	L1	-23.03
2	CISPR Average 469.5 kHz	28.49	N	-18.02
1	Quasi Peak 474 kHz	32.54	N	-23.90
1	Quasi Peak 13.56 MHz	47.95	L1	-12.04
2	CISPR Average 13.56 MHz	43.83	L1	-6.16

Note: Measurement Uncertainty is ± 4.2 dB at a level of confidence of 95%.

TEST REPORT

RADIATED EMISSIONS

Model: CHB24

Date of Test: February 26, 2020

Worst-Case Operating Mode: NFC Transmitting

Table 1
Pursuant to FCC Part 15 Section 15.225 Requirement

Polarization	Frequency (MHz)	Reading (dB μ V)	Pre-Amp Gain (dB)	Antenna Factor (dB)	Net at 3m (dB μ V/m)	Distance Factor (-dB)	Calculated at 30m (dB μ V/m)	Limit at 30m (dB μ V/m)	Margin (dB)
O	13.560	81.4	0	10.8	92.2	40.0	52.2	84.0	-31.8
O	27.120	48.5	0	9.5	58.0	40.0	18.0	29.5	-11.5

- NOTES:
1. Peak Detector Data unless otherwise stated.
 2. All measurements were made at 3 meters. Harmonic emissions not detected at the 3-meter distances were measured at 0.3-meter and an inverse proportional extrapolation was performed to compare the signal level to the 3-meter limit. No other harmonic emissions than those reported were detected at a test distance of 0.3-meter.
 3. Negative sign in the column shows value below limit.
 4. Loop antenna is used for the emissions below 30MHz.
 5. Emission (the row indicated by ***bold italic***) within the restricted band meets the requirement of FCC Part 15 Section 15.205.
 6. Measurement Uncertainty is ± 5.3 dB at a level of confidence of 95%.

TEST REPORT

Model: CHB24

Date of Test: February 26, 2020

Worst-Case Operating Mode: NFC Operating

Table 2
Pursuant to FCC Part 15 Section 15.209 Requirement

Polarization	Frequency (MHz)	Reading (dBμV)	Pre-amp (dB)	Antenna Factor (dB)	Net at 3m (dBμV/m)	Limit at 3m (dBμV/m)	Margin (dB)
H	40.722	34.4	16	10.0	28.4	40.0	-11.6
V	67.804	46.8	16	8.0	38.8	40.0	-1.2
V	72.000	47.2	16	7.0	38.2	40.0	-1.8
V	94.834	43.5	16	11.0	38.5	43.5	-5.0
V	176.248	33.4	16	19.0	36.4	43.5	-7.1
V	366.128	34.0	16	24.0	42.0	46.0	-4.0

- NOTES:
1. Peak Detector Data unless otherwise stated.
 2. All measurements were made at 3 meters. Harmonic emissions not detected at the 3-meter distances were measured at 0.3-meter and an inverse proportional extrapolation was performed to compare the signal level to the 3-meter limit. No other harmonic emissions than those reported were detected at a test distance of 0.3-meter.
 3. Negative sign in the column shows value below limit.
 4. Loop antenna is used for the emissions below 30MHz.
 5. Emission (the row indicated by ***bold italic***) within the restricted band meets the requirement of FCC Part 15 Section 15.205.
 6. Measurement Uncertainty is ±5.3dB at a level of confidence of 95%.

TEST REPORT

3.6 Frequency Stability

Data Table
Frequency Deviation with Voltage Variation

Nominal frequency	13.560MHz				
Temperature (°C) Humidity (%)	Voltage	Frequency (MHz)	Frequency error (ppm)	Limite (ppm)	Result
20°C 50%	102	13.560868	64.0	100	Pass
20°C 50%	120	13.560868	64.0	100	Pass
20°C 50%	132	13.560866	63.9	100	Pass
Min -20C 0%	102	13.560888	65.5	100	Pass
Min -20C 0%	120	13.560886	65.3	100	Pass
Min -20C 0%	132	13.560886	65.3	100	Pass
Max 50C 50%	102	13.560826	60.9	100	Pass
Max 50C 50%	120	13.560826	60.9	100	Pass
Max 50C 50%	132	13.560824	60.8	100	Pass

Operating frequency	13.560MHz			
Test Voltage (V)	Temperature (°C)	Measured frequency (MHz)	Frequency error (%)	Limit (%)
120	+ 50	13.560826	+0.0061	±0.01
	+ 40	13.560846	+0.0062	±0.01
	+ 30	13.560858	+0.0063	±0.01
	+ 20	13.560868	+0.0064	±0.01
	+ 10	13.560870	+0.0064	±0.01
	0	13.560874	+0.0064	±0.01
	- 10	13.560880	+0.0065	±0.01
	- 20	13.560884	+0.0065	±0.01

The device is deemed to comply with requirement of FCC15.225(e).

TEST REPORT

4.0 EQUIPMENT PHOTOGRAPHS

For electronic filing, the photographs are saved with filename: external photos.pdf and internal photos.pdf.

5.0 PRODUCT LABELLING

For electronics filing, the FCC ID label artwork and the label location are saved with filename: label.pdf.

6.0 TECHNICAL SPECIFICATIONS

For electronic filing, the block diagram and schematic of the tested EUT are saved with filename: block.pdf and circuit.pdf respectively.

7.0 INSTRUCTION MANUAL

For electronic filing, a preliminary copy of the Instruction Manual is saved with filename: manual.pdf.

This manual will be provided to the end-user with each unit sold/leased in the United States.

TEST REPORT

8.0 MISCELLANEOUS INFORMATION

The miscellaneous information includes details of the test procedure.

8.1 Measured Bandwidth

The plot saved in bw.pdf which shows the fundamental emission is confined in the specified band.

The worst case of sideband emission is lower than 15dB from the fundamental emission, thus which is also below the limit of $50.5 \text{ dB}\mu\text{V/m}$ in the range of (13.410-13.553MHz) and (13.710-14.010MHz) and the limit of $40.5 \text{ dB}\mu\text{V/m}$ in the frequency range of (13.110-14.410MHz) and (13.710-14.010MHz). In the frequency range from 13.110-14.010MHz, we can not find any emission higher than the fundamental emission. Therefore they meet the requirement of Section 15.225(a), (b), (c), & (d).

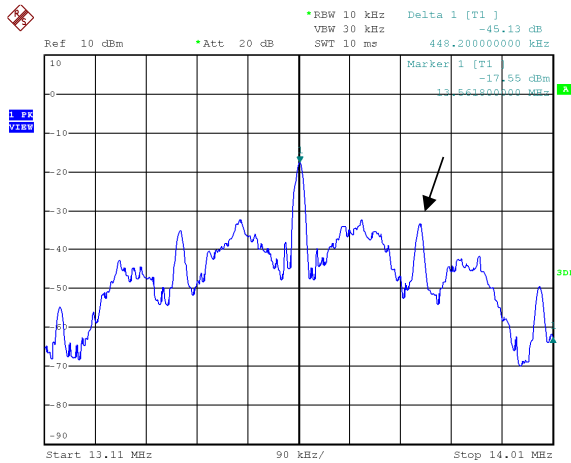

TEST REPORT

8.2 Discussion of Pulse Desensitization

Pulse desensitivity is not applicable for this device. Since the transmitter transmits the RF signal continuously.

8.3 Calculation of Average Factor

The average factor is not applicable for this device as the transmitted signal is a continuously signal.

TEST REPORT

8.4 Emissions Test Procedures

The following is a description of the test procedure used by Intertek Testing Services Hong Kong Ltd. in the measurements of transmitter operating under the Part 15, Subpart C rules.

The transmitting equipment under test (EUT) is placed on a wooden turntable which is four feet in diameter and approximately 0.8m in height above the ground plane for emission measurement at or below 1GHz and 1.5m in height above the ground plane for emission measurement above 1GHz. During the radiated emissions test, the turntable is rotated and any cables leaving the EUT are manipulated to find the configuration resulting in maximum emissions. The EUT is adjusted through all three orthogonal axis to obtain maximum emission levels. The antenna height and polarization are also varied during the testing to search for maximum signal levels. The height of the antenna is varied from one to four meters.

Detector function for radiated emissions is in peak mode. Average readings, when required, are taken by measuring the duty cycle of the equipment under test and subtracting the corresponding amount in dB from the measured peak readings. A detailed description for the calculation of the average factor can be found in Exhibit 8.3.

The frequency range scanned is from the lowest radio frequency signal generated in the device which is greater than 9 kHz to the tenth harmonic of the highest fundamental frequency or 40 GHz, whichever is lower.

TEST REPORT

8.4 Emissions Test Procedures (cont'd)

The EUT is warmed up for 15 minutes prior to the test.

AC power to the unit is varied from 85% to 115% nominal and variation in the fundamental emission field strength is recorded. If battery powered, a new, fully charged battery is used.

Conducted measurements were made as described in ANSI C63.10 (2013).

The IF bandwidth used for measurement of radiated signal strength was 100 kHz or greater when frequency is below 1000 MHz. Where pulsed transmissions of short enough pulse duration warrant, a greater bandwidth is selected according to the recommendations of Hewlett Packard Application Note 150-2. A discussion of whether pulse desensitivity is applicable to this unit is included in this report (See Exhibit 8.1). Above 1000 MHz, a resolution bandwidth of 3 MHz is used.

Transmitter measurements are normally conducted at a measurement distance of three meters. However, to assure low enough noise floor in the forbidden bands and above 1 GHz, signals are acquired at a distance of one meter or less. All measurements are extrapolated to three meters using inverse scaling, unless otherwise reported. Measurements taken at a closer distance are so marked. For line conducted emissions, the range scanned is 150 kHz to 30 MHz.

TEST REPORT

8.4.1 Radiated Emission Test Setup

The figure below shows the test setup, which is utilized to make these measurements.

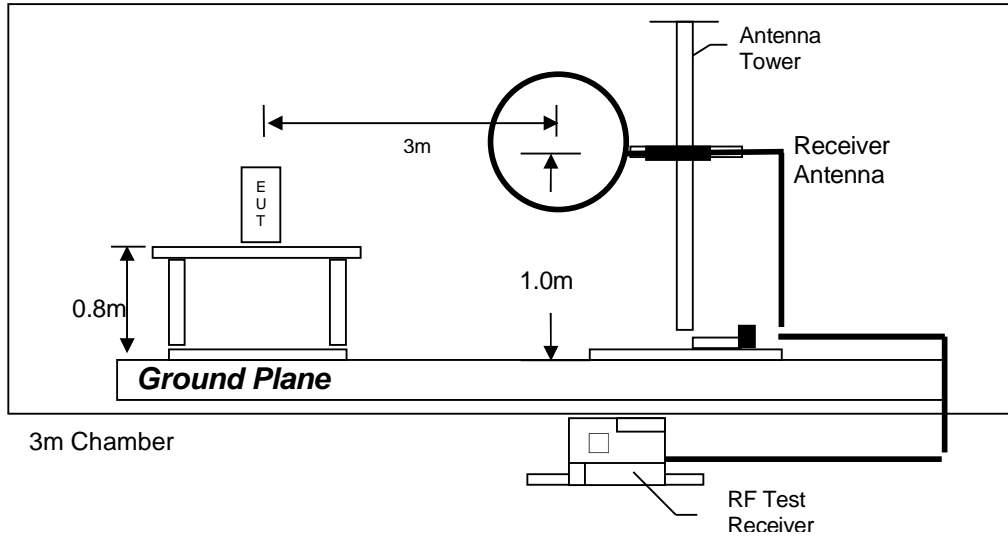

Test setup of radiated emissions up to 30MHz

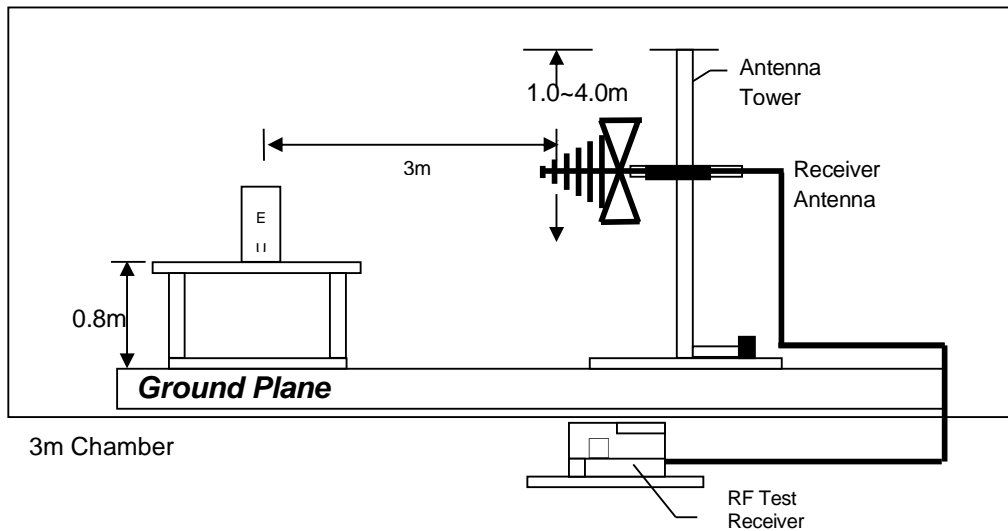

Test setup of radiated emissions below 1GHz

TEST REPORT

8.4.2 Conducted Emission Test Procedures

For tabletop equipment, the EUT along with its peripherals were placed on a 1.0m(W)×1.5m(L) and 0.8m in height wooden table. For floor-standing equipment, the EUT and all cables were insulated, if required, from the ground plane by up to 12 mm of insulating material. The EUT was adjusted to maintain a 0.4 meter space from a vertical reference plane. The EUT was connected to power mains through a line impedance stabilization network (LISN), which provided 50 ohm coupling impedance for measuring instrument and the chassis ground was bounded to the horizontal ground plane of shielded room. The excess power cable between the EUT and the LISN was bundled.

All connecting cables of EUT and peripherals were moved to find the maximum emission.

8.4.3 Conducted Emission Test Setup

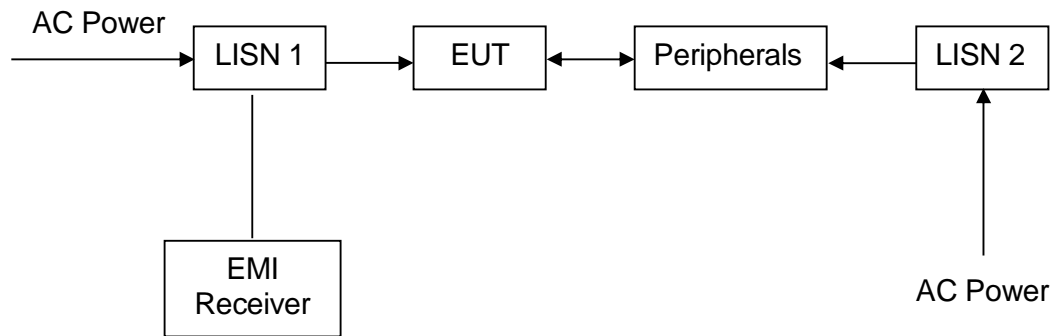

TEST REPORT

9.0 CONFIDENTIALITY REQUEST

For electronic filing, a preliminary copy of the confidentiality request is saved with filename: request.pdf.

10.0 EQUIPMENT LIST

1) Radiated Emissions Test

Equipment	EMI Test Receiver	Spectrum Analyzer	Biconical Antenna
Registration No.	EW-3156	EW-2249	EW-0571
Manufacturer	R&S	ROHDESCHWARZ	EMCO
Model No.	ESR26	FSP30	3104C
Calibration Date	August 01, 2019	May 16, 2019	July 23, 2019
Calibration Due Date	August 01, 2020	May 16, 2020	July 23, 2021

Equipment	Log Periodic Antenna	Double Ridged Guide Antenna	14m Double Shield RF Cable (20MHz - 6GHz)
Registration No.	EW-0447	EW-1133	EW-2074
Manufacturer	EMCO	EMCO	RADIALL
Model No.	3146	3115	Nm-RG142-
Calibration Date	September 25, 2019	November 29, 2018	March 31, 2019
Calibration Due Date	March 25, 2021	May 29, 2020	March 31, 2020

Equipment	15m 40GHz indoor RF Cable	RF Pre-amplifier (9kHz to 6000MHz)	Solid State Low Noise Pre-amplifier Assembly (1 - 18)GHz
Registration No.	EW-3032	EW-3424	EW-3229
Manufacturer	GREATBILLION	SCHWARZBECK	BONN ELEKTRO
Model No.	SMA(m) St-SMA (m) St, 15m long	BBV9744	BLMA 0118-5G
Calibration Date	May 14, 2019	July 23, 2019	June 28, 2019
Calibration Due Date	May 14, 2020	July 23, 2020	June 28, 2020

Equipment	Pyramidal Horn Antenna	Active Loop H-field (9kHz to 30MHz)
Registration No.	EW-0905	EW-3326
Manufacturer	EMCO	EMCO
Model No.	3160-09	6502
Calibration Date	July 23, 2019	March 21, 2019
Calibration Due Date	January 23, 2021	September 21, 2020

TEST REPORT

2) Conducted Emissions Test

Equipment	RF Cable 80cm (RG142) (9kHz to 30MHz)	Artificial Mains Network	EMI Test Receiver
Registration No.	EW-2451	EW-2874	EW-3156
Manufacturer	RADIALL	ROHDESCHWARZ	R&S
Model No.	RF Cable 80cm (RG142) (9kHz to 30MHz)	ENV-216	ESR26
Calibration Date	December 08, 2019	July 05, 2019	August 01, 2019
Calibration Due Date	December 08, 2020	July 05, 2020	August 01, 2020

3) Bandedge/Bandwidth Measurement

Equipment	40GHz 5m RF Cable	Spectrum Analyzer
Registration No.	EW-2701	EW-2249
Manufacturer	GREATBILLION	R&S
Model No.	sma m-m 5m 40G	FSP30
Calibration Date	May 14, 2019	May 16, 2019
Calibration Due Date	May 14, 2020	May 16, 2020

4) Frequency Error Measurement

Equipment	Frequency Counter	Temperature & Humidity Chamber
Registration No.	EW-2288	EW-2395
Manufacturer	AGILENTTECH	GIANT FORCE
Model No.	53181A	GTH-210-40-SP-AR
Calibration Date	March 21, 2019	September 04, 2019
Calibration Due Date	March 21, 2020	September 18, 2020

END OF TEST REPORT