



FCC RADIO TEST REPORT

FCC ID:2AB7K-D2311

Product : Nebula Mars

Trade Mark : Nebula

Model Name : D2311

Serial Model : N/A

Report No. : NTEK-2017NT04192779F5

Prepared for

Anker technology Co., Limited
Room 1318-19, Hollywood Plaza, 610 Nathan Road, Mongkok, Kowloon,
Hongkong

Prepared by

Shenzhen NTEK Testing Technology Co., Ltd.
1/F, Building E, Fenda Science Park, Sanwei Community,
Xixiang Street Bao'an District, Shenzhen 518126 P.R. China
Tel.: +86-755-6115 9388
Fax.: +86-755-6115 6599
Website:<http://www.ntek.org.cn>

TEST RESULT CERTIFICATION

Applicant's name: Anker technology Co., Limited
Address: Room 1318-19, Hollywood Plaza, 610 Nathan Road, Mongkok,
Kowloon, Hongkong

Manufacturer's Name: Anker technology Co., Limited
Address: Room 1318-19, Hollywood Plaza, 610 Nathan Road, Mongkok,
Kowloon, Hongkong

Product description

Product name.....: Nebula Mars

Model and/or type reference : D2311

Serial Model.....: N/A

Standards.....: FCC Part15.407: 01 Oct. 2015

Test procedure ANSI C63.10-2013 and KDB 789033 D02 General UNII Test
Procedures New Rules v01r01
FCC KDB 662911 D01 Multiple Transmitter Output v02r01
FCC KDB 662911 D02 MIMO With Cross Polarized Antenna V01

This device described above has been tested by NTEK, and the test results show that the equipment under test (EUT) is in compliance with the FCC requirements/ the Industry Canada requirements.. And it is applicable only to the tested sample identified in the report.

This report shall not be reproduced except in full, without the written approval of NTEK, this document may be altered or revised by NTEK, personnel only, and shall be noted in the revision of the document.

Date of Test

Date (s) of performance of tests 19 Apr. 2017 ~ 18 May. 2017

Date of Issue..... 18 Mar. 2017

Test Result..... **Pass**

Testing Engineer : Lebron Wang
(Lebron Wang)

Technical Manager : Jason Chen
(Jason Chen)

Authorized Signatory : Sam. Chen
(Sam Chen)

Table of Contents

	Page
1 . SUMMARY OF TEST RESULTS	5
1.1 TEST FACILITY	6
1.2 MEASUREMENT UNCERTAINTY	6
2 . GENERAL INFORMATION	7
2.1 GENERAL DESCRIPTION OF EUT	7
2.2 DESCRIPTION OF TEST MODES	10
2.3 BLOCK DIGRAM SHOWING THE CONFIGURATION OF SYSTEM TESTED	11
2.4 DESCRIPTION OF SUPPORT UNITS(CONDUCTED MODE)	12
2.5 EQUIPMENTS LIST FOR ALL TEST ITEMS	13
3 . EMC EMISSION TEST	15
3.1 CONDUCTED EMISSION MEASUREMENT	15
3.1.1 POWER LINE CONDUCTED EMISSION LIMITS	15
3.1.2 TEST PROCEDURE	16
3.1.3 DEVIATION FROM TEST STANDARD	16
3.1.4 TEST SETUP	16
3.1.5 EUT OPERATING CONDITIONS	16
3.1.6 TEST RESULTS	17
3.2 RADIATED EMISSION MEASUREMENT	21
3.2.1 APPLICABLE STANDARD	21
3.2.2 CONFORMANCE LIMIT	21
3.2.3 MEASURING INSTRUMENTS	21
3.2.4 TEST CONFIGURATION	21
3.2.5 TEST PROCEDURE	23
3.2.6 TEST RESULTS (BETWEEN 9KHZ – 30 MHZ)	24
3.2.7 TEST RESULTS (BETWEEN 30MHZ – 1GHZ)	25
3.2.8 TEST RESULTS (1GHZ-18GHZ)	29
4 . POWER SPECTRAL DENSITY TEST	37
4.1 APPLIED PROCEDURES / LIMIT	37
4.2 TEST PROCEDURE	38
4.3 DEVIATION FROM STANDARD	38
4.4 TEST SETUP	38
4.5 EUT OPERATION CONDITIONS	38
4.6 TEST RESULTS	39
5 . 26 DB & 99% EMISSION BANDWIDTH	45
5.1 APPLIED PROCEDURES / LIMIT	45
5.2 TEST PROCEDURE	45
5.3 EUT OPERATION CONDITIONS	46

Table of Contents

	Page
5.4 TEST RESULTS	47
6 . MINIMUM 6 DB BANDWIDTH	53
6.1 APPLIED PROCEDURES / LIMIT	53
6.2 TEST PROCEDURE	53
6.3 DEVIATION FROM STANDARD	53
6.4 TEST SETUP	53
6.5 EUT OPERATION CONDITIONS	53
6.6 TEST RESULTS	54
7 . MAXIMUM CONDUCTED OUTPUT POWER	60
7.1 PPLIED PROCEDURES / LIMIT	60
7.2 TEST PROCEDURE	60
7.3 DEVIATION FROM STANDARD	62
7.4 TEST SETUP	62
7.5 EUT OPERATION CONDITIONS	62
7.6 TEST RESULTS	63
8 . OUT OF BAND EMISSIONS	65
8.1 APPLICABLE STANDARD	65
8.2 TEST PROCEDURE	65
8.3 DEVIATION FROM STANDARD	65
8.4 TEST SETUP	65
8.5 EUT OPERATION CONDITIONS	65
8.6 TEST RESULTS	66
9.SPURIOUS RF CONDUCTED EMISSIONS	70
9.1CONFORMANCE LIMIT	70
9.2MEASURING INSTRUMENTS	70
9.3TEST SETUP	70
9.4TEST PROCEDURE	70
9.5TEST RESULTS	70
10. FREQUENCY STABILITY MEASUREMENT	79
10.1 LIMIT	79
10.2 TEST PROCEDURES	79
10.3 TEST SETUP LAYOUT	79
10.4 EUT OPERATION DURING TEST	79
10.5 TEST RESULTS	80
11. ANTENNA REQUIREMENT	86
11.1 STANDARD REQUIREMENT	86
11.2 EUT ANTENNA	86
APPENDIX-PHOTOGRAPHS OF EUT CONSTRUCTIONAL DETAILS	

1. SUMMARY OF TEST RESULTS

Test procedures according to the technical standards:

FCC Part15 (15.407) , Subpart E			
Standard Section	Test Item	Judgment	Remark
15.207	AC Power Line Conducted Emissions	PASS	
15.209(a), 15.407 (b)(1) 15.407 (b)(4) 15.407 (b)(6)	Spurious Radiated Emissions	PASS	
15.407 (a)(1) 15.407 (a)(3) 15.1049	26 dB and 99% Emission Bandwidth	PASS	
15.407(e)	Minimum 6 dB bandwidth	PASS	
15.407 (a)(1) 15.407 (a)(3)	Maximum Conducted Output Power	PASS	
2.1051, 15.407(b)(1) 15.407(b)(4)	Band Edges	PASS	
15.407 (a)(1) 15.407 (a)(3)	Power Spectral Density	PASS	
2.1051, 15.407(b)	Spurious Emissions at Antenna Terminals	PASS	
15.203	Antenna Requirement	PASS	

NOTE:

(1) "N/A" denotes test is not applicable in this Test Report

1.1 TEST FACILITY

Shenzhen NTEK Testing Technology Co., Ltd

Add.: 1/F, Building E, Fenda Science Park, Sanwei Community, Xixiang Street Bao'an District, Shenzhen 518126 P.R. China

FCC Registration No.:238937; IC Registration No.:9270A-1

CNAS Registration No.:L5516

1.2 MEASUREMENT UNCERTAINTY

The reported uncertainty of measurement $y \pm U$, where expanded uncertainty U is based on a standard uncertainty multiplied by a coverage factor of $k=2$, providing a level of confidence of approximately **95 %**.

No.	Item	Uncertainty
1	Conducted Emission Test	$\pm 1.38\text{dB}$
2	RF power,conducted	$\pm 0.16\text{dB}$
3	Spurious emissions,conducted	$\pm 0.21\text{dB}$
4	All emissions,radiated(<1G)	$\pm 4.68\text{dB}$
5	All emissions,radiated(>1G)	$\pm 4.89\text{dB}$
6	Temperature	$\pm 0.5^\circ\text{C}$
7	Humidity	$\pm 2\%$

2. GENERAL INFORMATION
2.1 GENERAL DESCRIPTION OF EUT

Equipment	Nebula Mars	
Trade Mark	Nebula	
Model Name	D2311	
Product Description	IEEE 802.11 WLAN Mode Supported	<input checked="" type="checkbox"/> 802.11a(20MHz channel bandwidth) <input checked="" type="checkbox"/> 802.11n(20MHz channel bandwidth) <input checked="" type="checkbox"/> 802.11n(40MHz channel bandwidth)
	Data Rate	802.11 a: 6,9,12,18,24,36,48,54Mbps; 802.11n(HT20):MCS0-MCS15; 802.11n(HT40):MCS0-MCS15;
	Modulation	OFDM with BPSK/QPSK/16QAM/64QAM/256QAM for 802.11a/n;
	Operating Frequency Range	<input checked="" type="checkbox"/> 5180-5240MHz for 802.11 a/n(HT20); 5190-5230MHz for 802.11 n(HT40); <input checked="" type="checkbox"/> 5745-5825 MHz for 802.11 a/n(HT20); 5755-5795 MHz for 802.11 a/n(HT40);
	Number of Channels	<input checked="" type="checkbox"/> 4 channels for 802.11a/N20 in the 5180-5240MHz band ; 2 channels for 802.11 N40 in the 5190-5230MHz band ; <input checked="" type="checkbox"/> 5 channels for 802.11 a/N20 in the 5745-5825MHz band ; 2 channels for 802.11 N40 in the 5755-5795MHz band ;
	Antenna Type	FPCB Antenna
	Smart system	<input checked="" type="checkbox"/> MIMO for 802.11a <input checked="" type="checkbox"/> MIMO for 802.11n
	Antenna Gain	See Table for Filed Antenna
		Based on the application, features, or specification exhibited in User's Manual, More details of EUT technical specification, please refer to the User's Manual.
Ratings	<input checked="" type="checkbox"/> DC supply: DC 11.4V/6700mAh from Battery or DC 19V from Adapter.	
Adapter	<input checked="" type="checkbox"/> Adapter supply: Model: NSA60ED-190300 Input:100~240V ~ 50/60Hz 1.5A Output: DC 19V, 3A Max	
Battery	DC 11.4V/6700mAh	
Connecting I/O Port(s)	Please refer to the User's Manual	

Note:

1. For a more detailed features description, please refer to the manufacturer's specifications or the User's Manual.
2. Frequency and Channel list for 802.11 a/n/ac (20MHz) (5180-5240MHz):

802.11a/n (20MHz) Carrier Frequency Channel							
Channel	Frequen cy (MHz)	Channel	Frequen cy (MHz)	Channel	Frequen cy (MHz)	Channel	Frequen cy (MHz)
36	5180	44	5220	-	-	-	-
40	5200	48	5240	-	-	-	-

Frequency and Channel list for 802.11 n (40MHz) (5190-5230MHz):

802.11n (40MHz) Carrier Frequency Channel							
Channel	Frequen cy (MHz)	Channel	Frequen cy (MHz)	Channel	Frequen cy (MHz)	Channel	Frequen cy (MHz)
38	5190	-	-	-	-	-	-
46	5230	-	-	-	-	-	-

Frequency and Channel list for 802.11 a/n (20 MHz) (5745-5825MHz):

802.11a/n (20 MHz) Carrier Frequency Channel							
Channel	Frequen cy (MHz)	Channel	Frequen cy (MHz)	Channel	Frequen cy (MHz)	Channel	Frequen cy (MHz)
149	5745	153	5765	157	5785	161	5805
165	5825	-	-	-	-	-	-

Frequency and Channel list for 802.11n (40MHz) (5755-5795MHz):

802.11n/ac 40MHz Carrier Frequency Channel					
Channel	Frequency (MHz)	Channel	Frequency (MHz)	Channel	Frequency (MHz)
151	5755	159	5795	-	-

The EUT has two types of antenna.

Tx Antenna

Antenna	Antenna Type	Antenna Gain(dBi)
		5.0G
A(main)	FPCB	1
B(aux)	FPCB	1

2.2 DESCRIPTION OF TEST MODES

To investigate the maximum EMI emission characteristics generates from EUT, the test system was pre-scanning tested base on the consideration of following EUT operation mode or test configuration mode which possible have effect on EMI emission level. Each of these EUT operation mode(s) or test configuration mode(s) mentioned above was evaluated respectively.

Pretest Mode	Description
Mode 1	Link Mode
Mode 2	802.11a / n20 CH36/ CH40/ CH 48 802.11a /n20 CH149/ CH157/ CH 165
Mode 3	802.11n40 CH38/ CH 46 802.11n40 CH 151 / CH 159

For Radiated Emission	
Final Test Mode	Description
Mode 1	Link Mode
Mode 2	802.11a /n20 CH36/ CH40/ CH 48 802.11a /n20 CH149/ CH157/ CH 165
Mode 3	802.11n40 CH38/ CH 46 802.11n40 CH 151 / CH 159

Note:

- (1) The measurements are performed at the highest, middle, lowest available channels.
- (2) The measurements are performed at all Bit Rate of Transmitter, the worst data was reported

2.3 BLOCK DIGRAM SHOWING THE CONFIGURATION OF SYSTEM TESTED

For AC Conducted Emission Mode

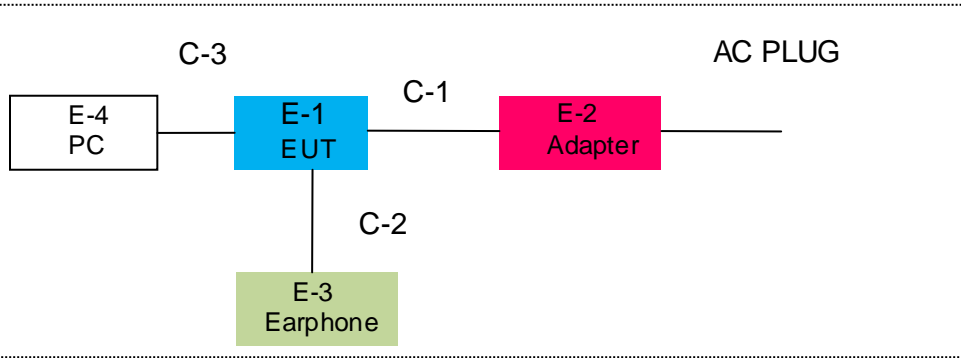

For Radiated Test Cases

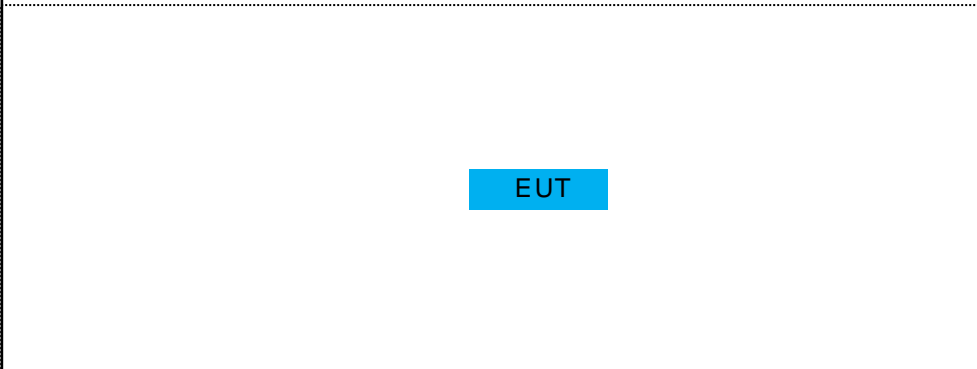

For Conducted Test Cases

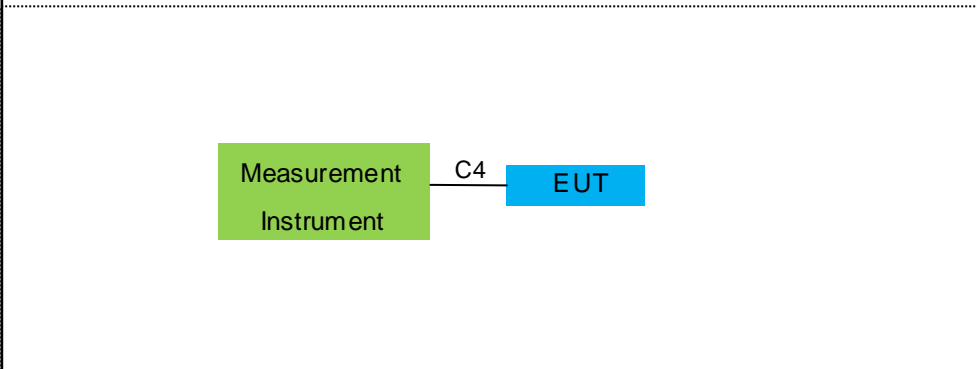

Note: The temporary antenna connector is soldered on the PCB board in order to perform conducted tests and this temporary antenna connector is listed in the equipment list.

2.4 DESCRIPTION OF SUPPORT UNITS(CONDUCTED MODE)

The EUT has been tested as an independent unit together with other necessary accessories or support units. The following support units or accessories were used to form a representative test configuration during the tests.

Item	Equipment	Brand	Model/Type No.	Series No.	Note
E-1.	Nebula Mars	Nebula	D2311	2AB7K-D2311	EUT
E-2	Adapter	N/A	NSA60ED-190300	N/A	Peripherals
E-3	Earphone	N/A	2688	N/A	Peripherals
E-4	PC	DELL	FT4Y23X	34413561645	Peripherals

Item	Cable Type	Shielded Type	Ferrite Core	Length	Note
C-1	Power Cable	NO	NO	1.2m	C-1
C-2	Earphone Cable	NO	NO	0.8m	C-2
C-3	HDMI Cable	NO	NO	1.0m	C-3
C-4	RF Cable	NO	NO	0.5m	C-4

Note:

- (1) The support equipment was authorized by Declaration of Confirmation.
- (2) For detachable type I/O cable should be specified the length in cm in 『Length』 column.

2.5 EQUIPMENTS LIST FOR ALL TEST ITEMS

Radiation Test equipment

Item	Kind of Equipment	Manufacturer	Type No.	Serial No.	Last calibration	Calibrated until	Calibration period
1	Spectrum Analyzer	Agilent	E4407B	MY45108040	2016.07.06	2017.07.05	1 year
2	Spectrum Analyzer	Agilent	N9020A	MY49100060	2016.07.06	2017.07.05	1 year
3	EMI Test Receiver	Agilent	N9038A	MY53227146	2016.07.06	2017.07.05	1 year
4	Test Receiver	R&S	ESPI	101318	2016.07.06	2017.07.05	1 year
5	Bilog Antenna	TESEQ	CBL6111D	31216	2016.07.06	2017.07.05	1 year
6	50Ω Coaxial Switch	Anritsu	MP59B	6200264416	2016.07.06	2017.07.05	1 year
7	Spectrum Analyzer	ADVANTEST	R3132	150900201	2016.07.06	2017.07.05	1 year
8	Horn Antenna	EM	EM-AH-10180	2011071402	2016.07.06	2017.07.05	1 year
9	Horn Ant	Schwarzbeck	BBHA 9170	9170-181	2016.07.06	2017.07.05	1 year
10	Amplifier	EM	EM-30180	060538	2016.12.22	2017.12.21	1 year
11	Amplifier	MITEQ	TTA1840-35-HG	177156	2016.07.06	2017.07.05	1 year
12	Loop Antenna	ARA	PLA-1030/B	1029	2016.07.06	2017.07.05	1 year
13	Power Meter	R&S	NRVS	100696	2016.07.06	2017.07.05	1 year
14	Power Sensor	R&S	URV5-Z4	0395.1619.05	2016.07.06	2017.07.05	1 year
15	Test Cable	N/A	R-01	N/A	2016.07.06	2017.07.05	1 year
16	Test Cable	N/A	R-02	N/A	2016.07.06	2017.07.05	1 year
17	High Test Cable(1G-40 GHz)	N/A	R-03	N/A	2016.07.06	2017.07.05	1 year
18	High Test Cable(1G-40 GHz)	N/A	R-04	N/A	2016.07.06	2017.07.05	1 year

Conduction Test equipment

Item	Kind of Equipment	Manufacturer	Type No.	Serial No.	Last calibration	Calibrated until	Calibration period
1	Test Receiver	R&S	ESCI	101160	2016.07.06	2017.07.05	1 year
2	LISN	R&S	ENV216	101313	2016.08.24	2017.08.23	1 year
3	LISN	EMCO	3816/2	00042990	2016.07.06	2017.07.05	1 year
4	50Ω Coaxial Switch	Anritsu	MP59B	6200264417	2016.07.06	2017.07.05	1 year
5	Passive Voltage Probe	R&S	ESH2-Z3	100196	2016.07.06	2017.07.05	1 year
6	Absorbing clamp	R&S	MOS-21	100423	2016.07.06	2017.07.05	1 year
7	Test Cable	N/A	C01	N/A	2016.06.08	2017.06.07	1 year
8	Test Cable	N/A	C02	N/A	2016.06.08	2017.06.07	1 year
9	Test Cable	N/A	C03	N/A	2016.06.08	2017.06.07	1 year

1	Attenuation	MCE	24-10-34	BN9258	2016.07.06	2017.07.05	1 year
---	-------------	-----	----------	--------	------------	------------	--------

3. EMC EMISSION TEST

3.1 CONDUCTED EMISSION MEASUREMENT

3.1.1 POWER LINE CONDUCTED EMISSION Limits (Frequency Range 150KHz-30MHz)

FREQUENCY (MHz)	Class A (dBuV)		Class B (dBuV)		Standard
	Quasi-peak	Average	Quasi-peak	Average	
0.15 -0.5	79.00	66.00	66 - 56 *	56 - 46 *	CISPR
0.50 -5.0	73.00	60.00	56.00	46.00	CISPR
5.0 -30.0	73.00	60.00	60.00	50.00	CISPR

0.15 -0.5	79.00	66.00	66 - 56 *	56 - 46 *	FCC/ RSS-247
0.50 -5.0	73.00	60.00	56.00	46.00	FCC/ RSS-247
5.0 -30.0	73.00	60.00	60.00	50.00	FCC/ RSS-247

Note:

- (1) The tighter limit applies at the band edges.
- (2) The limit of " * " marked band means the limitation decreases linearly with the logarithm of the frequency in the range.

The following table is the setting of the receiver

Receiver Parameters	Setting
Attenuation	10 dB
Start Frequency	0.15 MHz
Stop Frequency	30 MHz
IF Bandwidth	9 kHz

3.1.2 TEST PROCEDURE

- The EUT was placed 0.8 meters from the horizontal ground plane with EUT being connected to the power mains through a line impedance stabilization network (LISN). All other support equipments powered from additional LISN(s). The LISN provide 50 Ohm/ 50uH of coupling impedance for the measuring instrument.
- Interconnecting cables that hang closer than 40 cm to the ground plane shall be folded back and forth in the center forming a bundle 30 to 40 cm long.
- I/O cables that are not connected to a peripheral shall be bundled in the center. The end of the cable may be terminated, if required, using the correct terminating impedance. The overall length shall not exceed 1 m.
- LISN at least 80 cm from nearest part of EUT chassis.
- For the actual test configuration, please refer to the related Item –EUT Test Photos.

3.1.3 DEVIATION FROM TEST STANDARD

No deviation

3.1.4 TEST SETUP

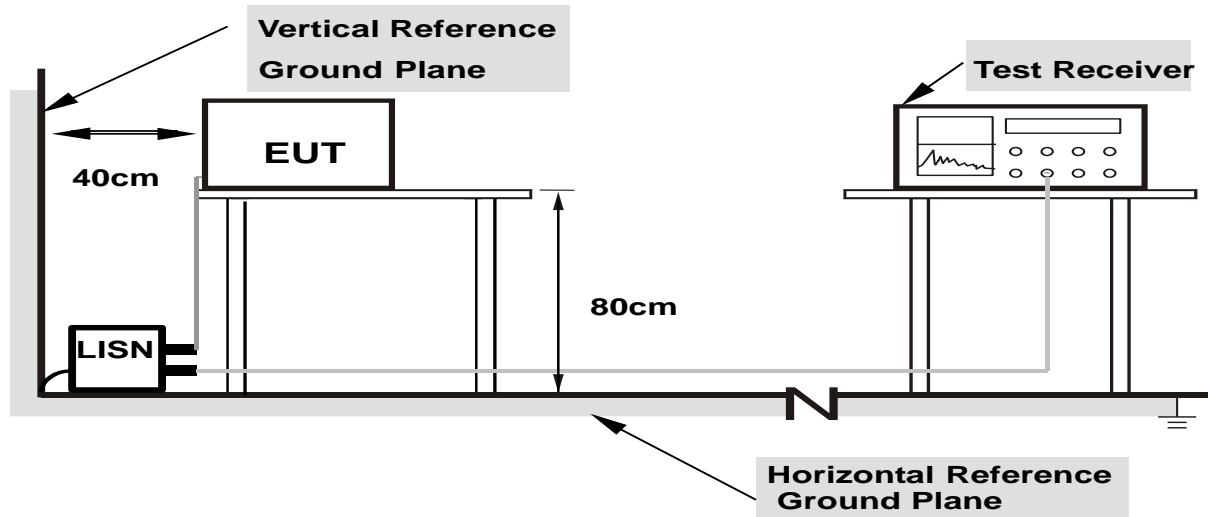

- Note: 1. Support units were connected to second LISN.**
2. Both of LISNs (AMN) are 80 cm from EUT and at least 80 from other units and other metal planes

3.1.5 EUT OPERATING CONDITIONS

The EUT was configured for testing in a typical fashion (as a customer would normally use it). The EUT has been programmed to continuously transmit during test. This operating condition was tested and used to collect the included data.

3.1.6 TEST RESULTS

EUT :	Nebula Mars	Model Name. :	D2311
Temperature :	26 °C	Relative Humidity :	56%
Pressure :	1010hPa	Phase :	L
Test Voltage :	DC 19V from Adapter AC120V/60Hz	Test Mode :	Mode 1

Frequency (MHz)	Meter Reading (dBμV)	Factor (dB)	Emission Level (dBμV)	Limits (dBμV)	Margin (dB)	Detector Type
0.194	58.17	0.13	58.3	63.86	-5.56	QP
0.194	43.91	0.13	44.04	53.86	-9.82	AVG
0.326	49.05	0.13	49.18	59.55	-10.37	QP
0.326	38.97	0.13	39.1	49.55	-10.45	AVG
0.63	45.92	0.18	46.1	56	-9.9	QP
0.63	30.69	0.18	30.87	46	-15.13	AVG
3.294	50.03	0.21	50.24	56	-5.76	QP
3.294	37.73	0.21	37.94	46	-8.06	AVG
6.7698	43.72	0.26	43.98	60	-16.02	QP
6.7698	34.16	0.26	34.42	50	-15.58	AVG
16.3899	42.85	0.35	43.2	60	-16.8	QP
16.3899	22.95	0.35	23.3	50	-26.7	AVG

Remark:

1. All readings are Quasi-Peak and Average values.
2. Factor = Insertion Loss + Cable Loss.

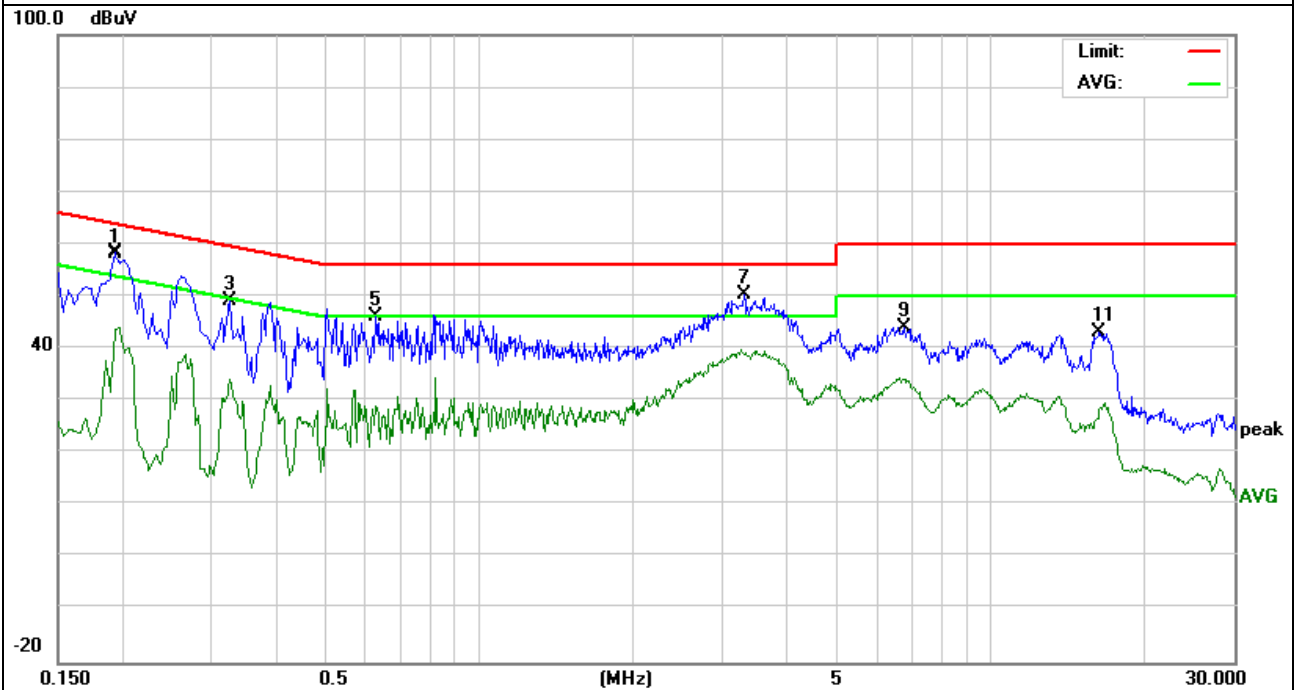

EUT :	Nebula Mars	Model Name. :	D2311
Temperature :	26 °C	Relative Humidity :	56%
Pressure :	1010hPa	Phase :	N
Test Voltage :	DC 19V from Adapter AC120V/60Hz	Test Mode :	Mode 1

Frequency (MHz)	Meter Reading (dBμV)	Factor (dB)	Emission Level (dBμV)	Limits (dBμV)	Margin (dB)	Detector Type
0.1965	56.38	0.12	56.5	63.75	-7.25	QP
0.1965	34.63	0.12	34.75	53.75	-19	AVG
0.258	56.28	0.11	56.39	61.49	-5.1	QP
0.258	34.34	0.11	34.45	51.49	-17.04	AVG
0.5856	51.45	0.19	51.64	56	-4.36	QP
0.5856	34.4	0.19	34.59	46	-11.41	AVG
2.878	47.27	0.22	47.49	56	-8.51	QP
2.878	43.47	0.22	43.69	46	-2.31	AVG
7.9977	45.41	0.26	45.67	60	-14.33	QP
7.9977	39.3	0.26	39.56	50	-10.44	AVG
13.4699	43.14	0.3	43.44	60	-16.56	QP
13.4699	43.96	0.3	44.26	50	-5.74	AVG

Remark:

1. All readings are Quasi-Peak and Average values.
2. Factor = Insertion Loss + Cable Loss.

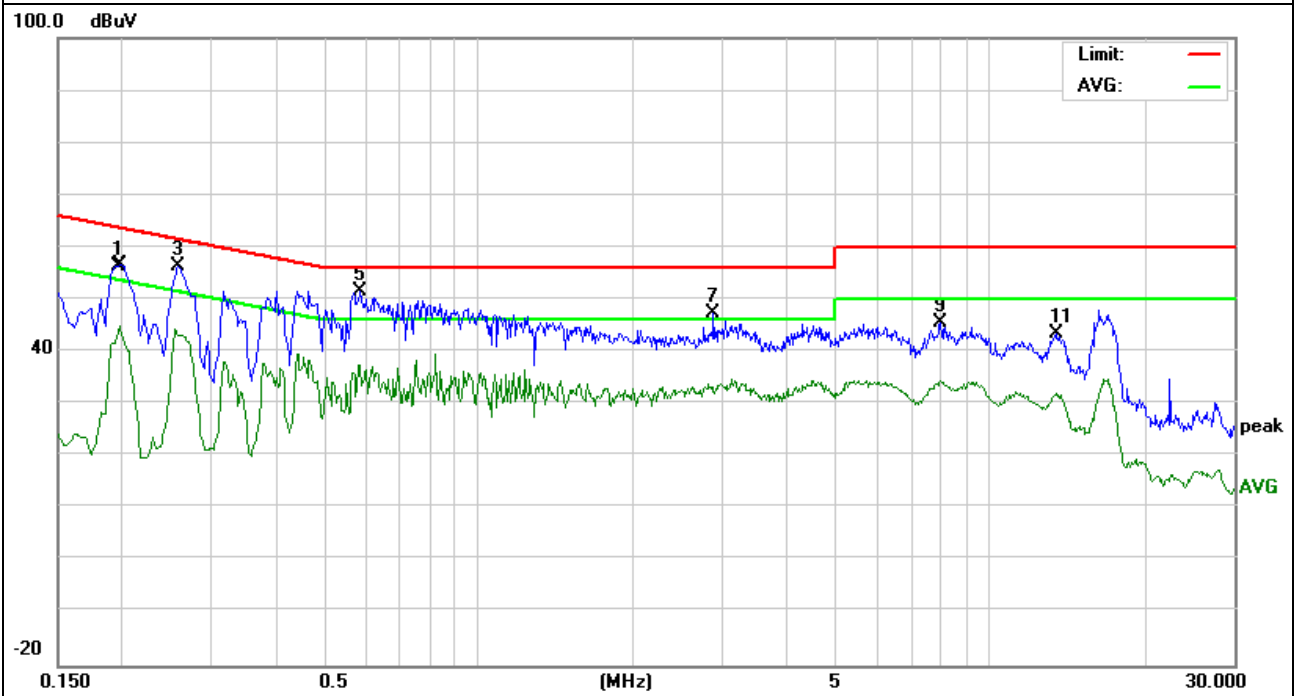

EUT :	Nebula Mars	Model Name. :	D2311
Temperature :	26 °C	Relative Humidity :	56%
Pressure :	1010hPa	Phase :	L
Test Voltage :	DC 19V from Adapter AC240V/60Hz	Test Mode :	Mode 1

Frequency (MHz)	Meter Reading (dBμV)	Factor (dB)	Emission Level (dBμV)	Limits (dBμV)	Margin (dB)	Detector Type
0.194	58.17	0.13	58.3	63.86	-5.56	QP
0.194	43.91	0.13	44.04	53.86	-9.82	AVG
0.266	49.06	0.12	49.18	61.24	-12.06	QP
0.266	38.98	0.12	39.1	51.24	-12.14	AVG
0.3899	48.7	0.14	48.84	58.06	-9.22	QP
0.3899	30.73	0.14	30.87	48.06	-17.19	AVG
0.506	47.59	0.14	47.73	56	-8.27	QP
0.506	37.8	0.14	37.94	46	-8.06	AVG
0.8139	46.18	0.2	46.38	56	-9.62	QP
0.8139	34.22	0.2	34.42	46	-11.58	AVG
17.514	49.88	0.36	50.24	60	-9.76	QP
17.514	22.94	0.36	23.3	50	-26.7	AVG

Remark:

1. All readings are Quasi-Peak and Average values.
2. Factor = Insertion Loss + Cable Loss.

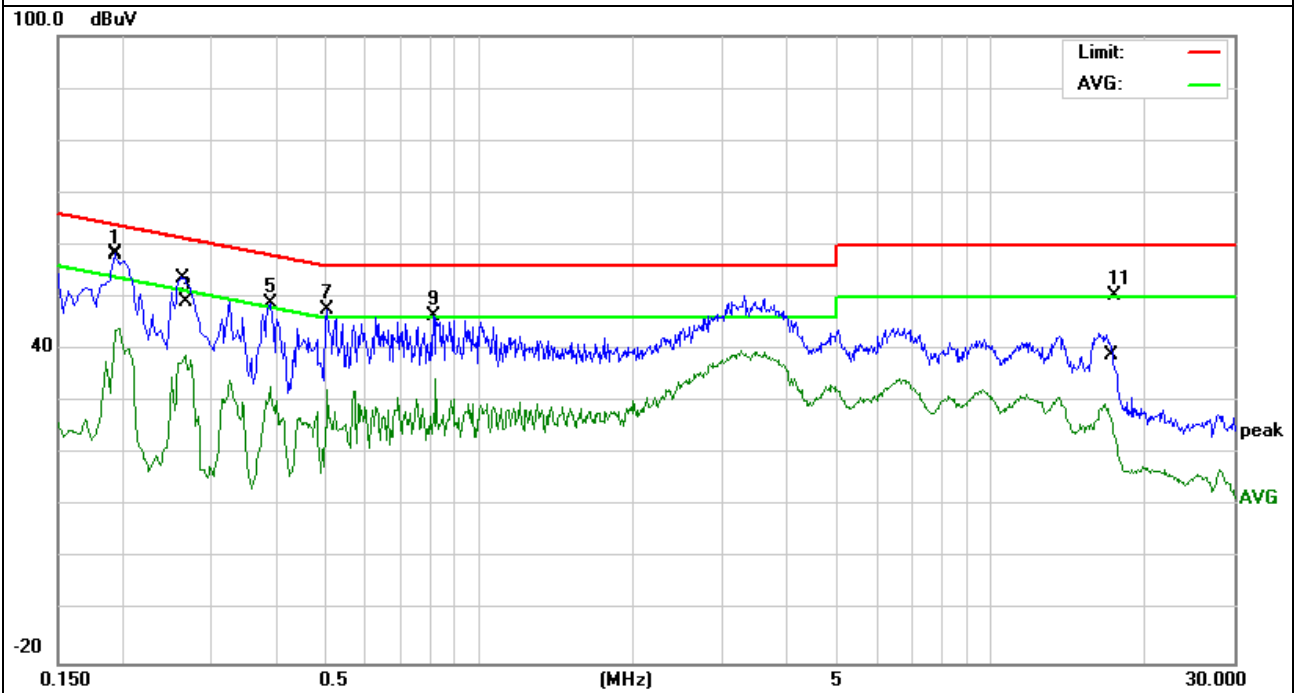

EUT :	Nebula Mars	Model Name. :	D2311
Temperature :	26 °C	Relative Humidity :	56%
Pressure :	1010hPa	Phase :	N
Test Voltage :	DC 19V from Adapter AC240V/60Hz	Test Mode :	Mode 1-5.2G

Frequency (MHz)	Meter Reading (dBμV)	Factor (dB)	Emission Level (dBμV)	Limits (dBμV)	Margin (dB)	Detector Type
0.198	56.44	0.12	56.56	63.69	-7.13	QP
0.198	43.57	0.12	43.69	53.69	-10	AVG
0.254	56.28	0.11	56.39	61.62	-5.23	QP
0.254	44.15	0.11	44.26	51.62	-7.36	AVG
0.402	51.24	0.17	51.41	57.81	-6.4	QP
0.402	39.39	0.17	39.56	47.81	-8.25	AVG
0.466	51.31	0.16	51.47	56.58	-5.11	QP
0.466	34.43	0.16	34.59	46.58	-11.99	AVG
0.5858	51.45	0.19	51.64	56	-4.36	QP
0.5858	34.26	0.19	34.45	46	-11.55	AVG
16.3899	47.71	0.32	48.03	60	-11.97	QP
16.3899	34.43	0.32	34.75	50	-15.25	AVG

Remark:

1. All readings are Quasi-Peak and Average values.
2. Factor = Insertion Loss + Cable Loss.

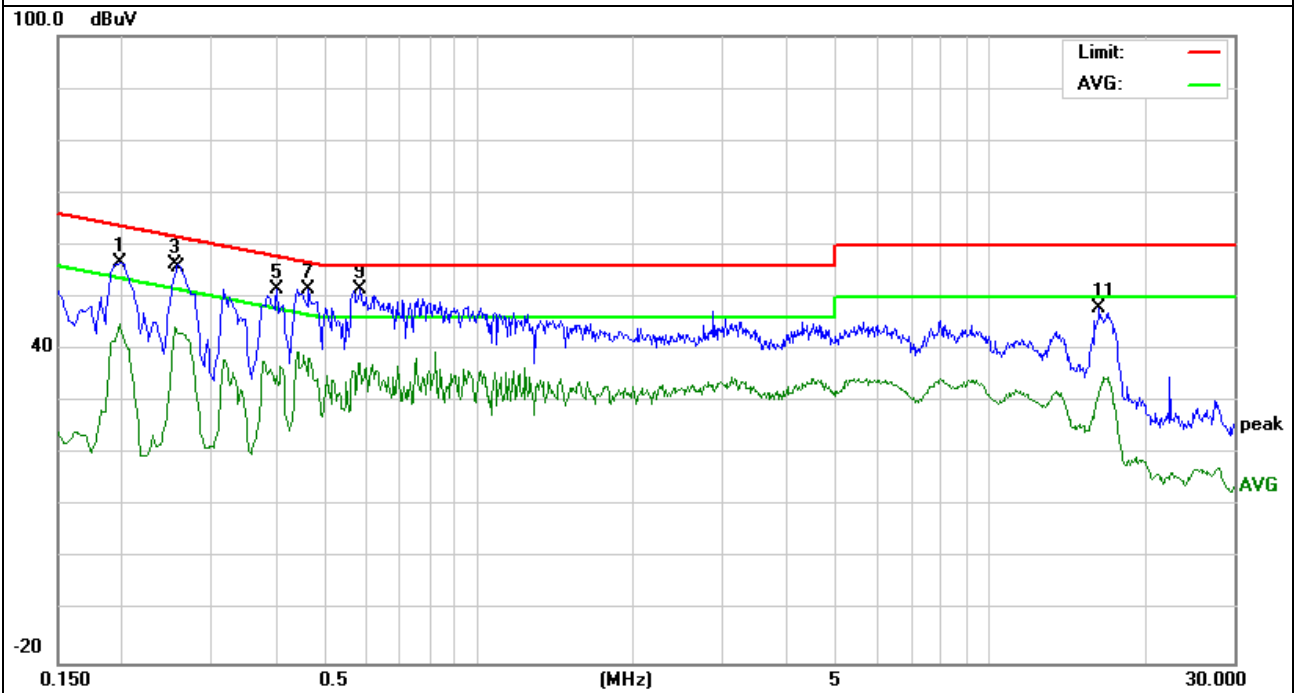

3.2 RADIATED EMISSION MEASUREMENT

3.2.1 APPLICABLE STANDARD

According to FCC Part 15.407(d) and 15.209

3.2.2 CONFORMANCE LIMIT

According to FCC Part 15.407(b)(7): radiated emissions which fall in the restricted bands, as defined in §15.205(a), must also comply with the radiated emission limits specified in §15.209(a) (see §15.205(c)).
According to FCC Part 15.205, Restricted bands

MHz	MHz	MHz	GHz
0.090-0.110	16.42-16.423	399.9-410	4.5-5.15
10.495-0.505	16.69475-16.69525	608-614	5.35-5.46
2.1735-2.1905	16.80425-16.80475	960-1240	7.25-7.75
4.125-4.128	25.5-25.67	1300-1427	8.025-8.5
4.17725-4.17775	37.5-38.25	1435-1626.5	9.0-9.2
4.20725-4.20775	73-74.6	1645.5-1646.5	9.3-9.5
6.215-6.218	74.8-75.2	1660-1710	10.6-12.7
6.26775-6.26825	123-138	2200-2300	14.47-14.5
8.291-8.294	149.9-150.05	2310-2390	15.35-16.2
8.362-8.366	156.52475-156.52525	2483.5-2500	17.7-21.4
8.37625-8.38675	156.7-156.9	2690-2900	22.01-23.12
8.41425-8.41475	162.0125-167.17	3260-3267	23.6-24.0
12.29-12.293	167.72-173.2	3332-3339	31.2-31.8
12.51975-12.52025	240-285	3345.8-3358	36.43-36.5
12.57675-12.57725	322-335.4	3600-4400	(2)
13.36-13.41			

20dBc in any 100 kHz bandwidth outside the operating frequency band. In case the emission fall within the restricted band specified on 15.205(a), then the 15.209(a) limit in the table below has to be followed.

Restricted Frequency(MHz)	Field Strength (µV/m)	Field Strength (dBµV/m)	Measurement Distance
0.009~0.490	2400/F(KHz)	20 log (uV/m)	300
0.490~1.705	2400/F(KHz)	20 log (uV/m)	30
1.705~30.0	30	29.5	30
30-88	100	40	3
88-216	150	43.5	3
216-960	200	46	3
Above 960	500	54	3

Limits of Radiated Emission Measurement(Above 1000MHz)

Frequency(MHz)	Class B (dBuV/m) (at 3M)	
	PEAK	AVERAGE
Above 1000	74	54

- Remark :1. Emission level in dBuV/m=20 log (uV/m)
 2. Measurement was performed at an antenna to the closed point of EUT distance of meters.
 3. Distance extrapolation factor =40log(Specific distance/ test distance)(dB);
 Limit line=Specific limits(dBuV) + distance extrapolation factor.

3.2.3 MEASURING INSTRUMENTS

The Measuring equipment is listed in the section 6.3 of this test report.

3.2.4 TEST CONFIGURATION

(a) For radiated emissions below 30MHz

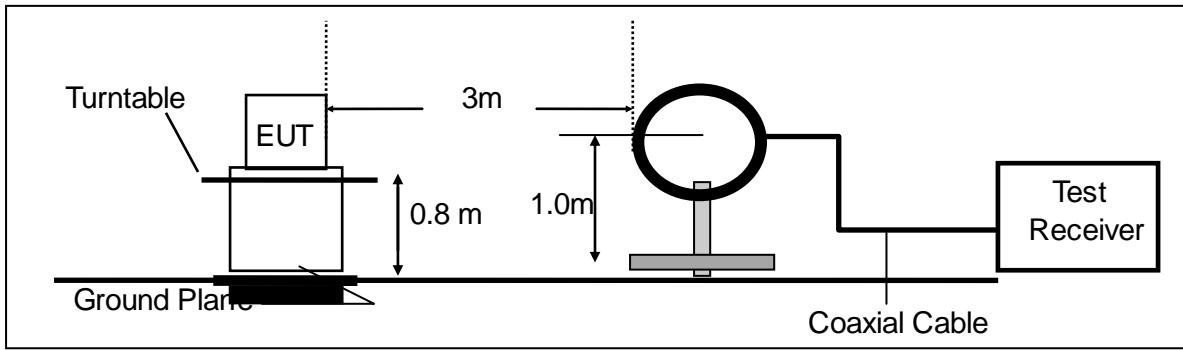

(b) For radiated emissions from 30MHz to 1000MHz

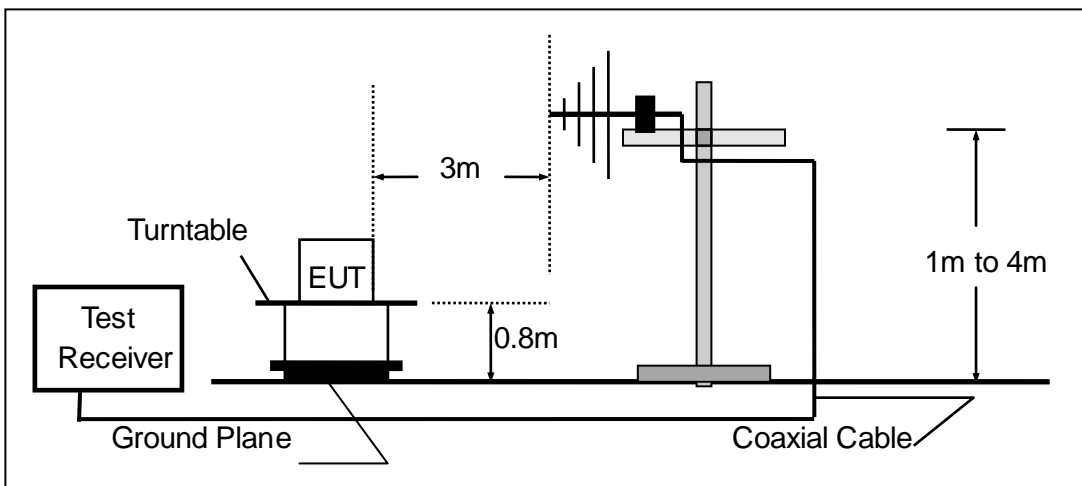

(c) For radiated emissions above 1000MHz

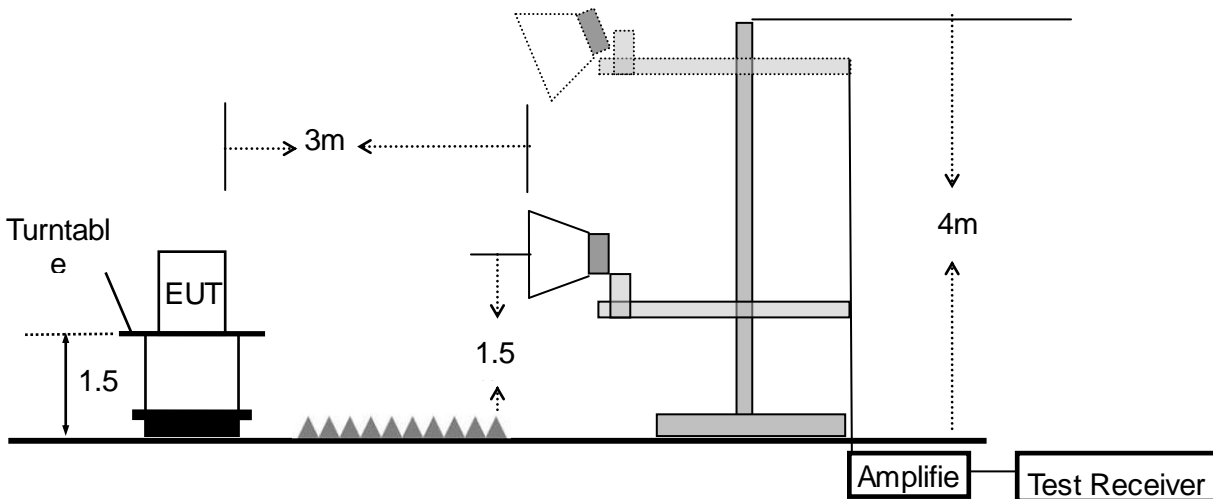

3.2.5 TEST PROCEDURE

The test site semi-anechoic chamber has met the requirement of NSA tolerance 4 dB according to the standards: ANSI C63.10-2013. The test distance is 3m. The setup is according to the requirements in Section 13.1.4.1 of ANSI C63.10-2013 and CAN/CSA-CEI/IEC CISPR 22.

This test is required for any spurious emission that falls in a Restricted Band, as defined in Section 15.205. It must be performed with the highest gain of each type of antenna proposed for use with the EUT.

Use the following spectrum analyzer settings:

Spectrum Parameter	Setting
Attenuation	Auto
Start Frequency	1000 MHz
Stop Frequency	10th carrier harmonic
RB / VB (emission in restricted band)	1 MHz / 1 MHz for Peak, 1 MHz / 10Hz for Average

Receiver Parameter	Setting
Attenuation	Auto
Start ~ Stop Frequency	9kHz~150kHz / RB 200Hz for QP
Start ~ Stop Frequency	150kHz~30MHz / RB 9kHz for QP
Start ~ Stop Frequency	30MHz~1000MHz / RB 120kHz for QP

- The measuring distance of at 3 m shall be used for measurements at frequency up to 1GHz. For frequencies above 1GHz, any suitable measuring distance may be used.
- The EUT was placed on the top of a rotating table 0.8 m for below 1GHz and 1.5m for above 1GHz the ground at a 3 meter. The table was rotated 360 degrees to determine the position of the highest radiation.
- The height of the equipment or of the substitution antenna shall be 0.8 m for below 1GHz and 1.5m for above 1GHz; the height of the test antenna shall vary between 1 m to 4 m. Both horizontal and vertical polarizations of the antenna are set to make the measurement.
- The initial step in collecting conducted emission data is a spectrum analyzer peak detector mode pre-scanning the measurement frequency range. Significant peaks are then marked and then Quasi Peak detector mode re-measured.
- If the Peak Mode measured value compliance with and lower than Quasi Peak Mode Limit, the EUT shall be deemed to meet QP Limits and then no additional QP Mode measurement performed.
- For the actual test configuration, please refer to the related Item –EUT Test Photos.

Note:

Both horizontal and vertical antenna polarities were tested and performed pretest to three orthogonal axis. The worst case emissions were reported

During the radiated emission test, the Spectrum Analyzer was set with the following configurations:

Frequency Band (MHz)	Function	Resolution bandwidth	Video Bandwidth
30 to 1000	QP	120 kHz	300 kHz
Above 1000	Peak	1 MHz	1 MHz
	Average	1 MHz	10 Hz

Note: for the frequency ranges below 30 MHz, a narrower RBW is used for these ranges but the measured value should add a RBW correction factor (RBWCF) where $RBWCF [dB] = 10 \cdot \lg(100 [kHz] / \text{narrower RBW [kHz]})$. , the narrower RBW is 1 kHz and RBWCF is 20 dB for the frequency 9 kHz to 150 kHz, and the narrower RBW is 10 kHz and RBWCF is 10 dB for the frequency 150 kHz to 30 MHz.

3.2.6 TEST RESULTS (BETWEEN 9KHZ – 30 MHZ)

EUT:	Nebula Mars	Model Name. :	D2311
Temperature:	20 °C	Relative Humidity:	48%
Pressure:	1010 hPa	Test Voltage :	DC 11.4V
Test Mode :	TX	Polarization :	--

Freq. (MHz)	Reading (dBuV/m)	Limit (dBuV/m)	Margin (dB)	State P/F
--	--	--	--	N/A
--	--	--	--	N/A

NOTE:

The amplitude of spurious emissions which are attenuated by more than 20dB below the permissible value has no need to be reported.

Distance extrapolation factor = $40 \log(\text{specific distance}/\text{test distance})(\text{dB})$;

Limit line = specific limits(dBuv) + distance extrapolation factor.

3.2.7 TEST RESULTS (BETWEEN 30MHZ – 1GHZ)

EUT :	Nebula Mars	Model Name :	D2311
Temperature :	20 °C	Relative Humidity :	48%
Pressure :	1010 hPa	Test Voltage :	DC 11.4V
Test Mode :	TX(5.2G)- 802.11a (High CH)		

Polar (H/V)	Frequency	Meter Reading	Factor	Emission Level	Limits	Margin	Remark
	(MHz)	(dBuV)	(dB)	(dBuV/m)	(dBuV/m)	(dB)	
V	39.2991	18.44	15.36	33.8	40	-6.2	QP
V	53.8817	27.38	7.45	34.83	40	-5.17	QP
V	113.3161	24.64	13.02	37.66	43.5	-5.84	QP
V	144.8418	25.72	12.98	38.7	43.5	-4.8	QP
V	233.3487	26.06	12.54	38.6	46	-7.4	QP
V	389.3548	14.13	19.71	33.84	46	-12.16	QP

Remark:

Absolute Level= ReadingLevel+ Factor, Margin= Absolute Level - Limit

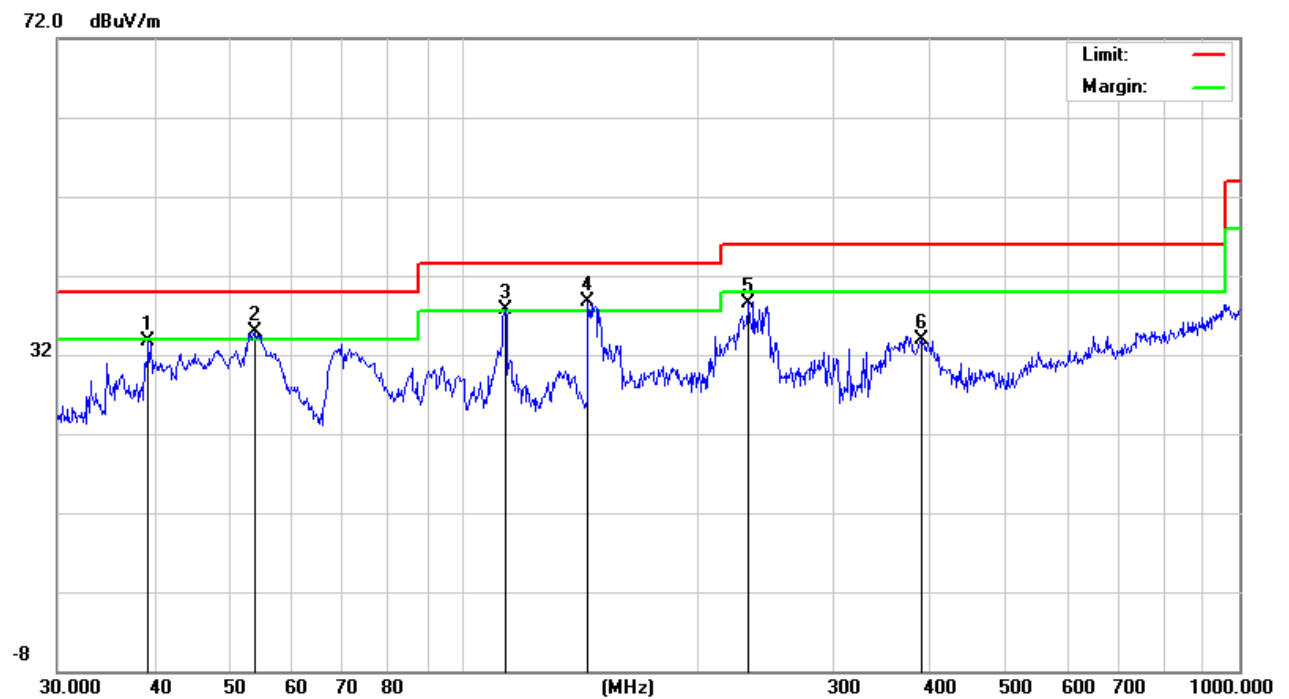

Polar (H/V)	Frequency	Meter Reading	Factor	Emission Level	Limits	Margin	Remark
	(MHz)	(dBuV)	(dB)	(dBuV/m)	(dBuV/m)	(dB)	
H	111.7377	18.2	12.82	31.02	43.5	-12.48	QP
H	121.123	16.12	13.82	29.94	43.5	-13.56	QP
H	152.1297	24.52	12.88	37.4	43.5	-6.1	QP
H	204.955	28.22	10.74	38.96	43.5	-4.54	QP
H	213.7632	25.66	11.64	37.3	43.5	-6.2	QP
H	962.1621	7.65	31.33	38.98	54	-15.02	QP

Remark:

Absolute Level= ReadingLevel+ Factor, Margin= Absolute Level - Limit

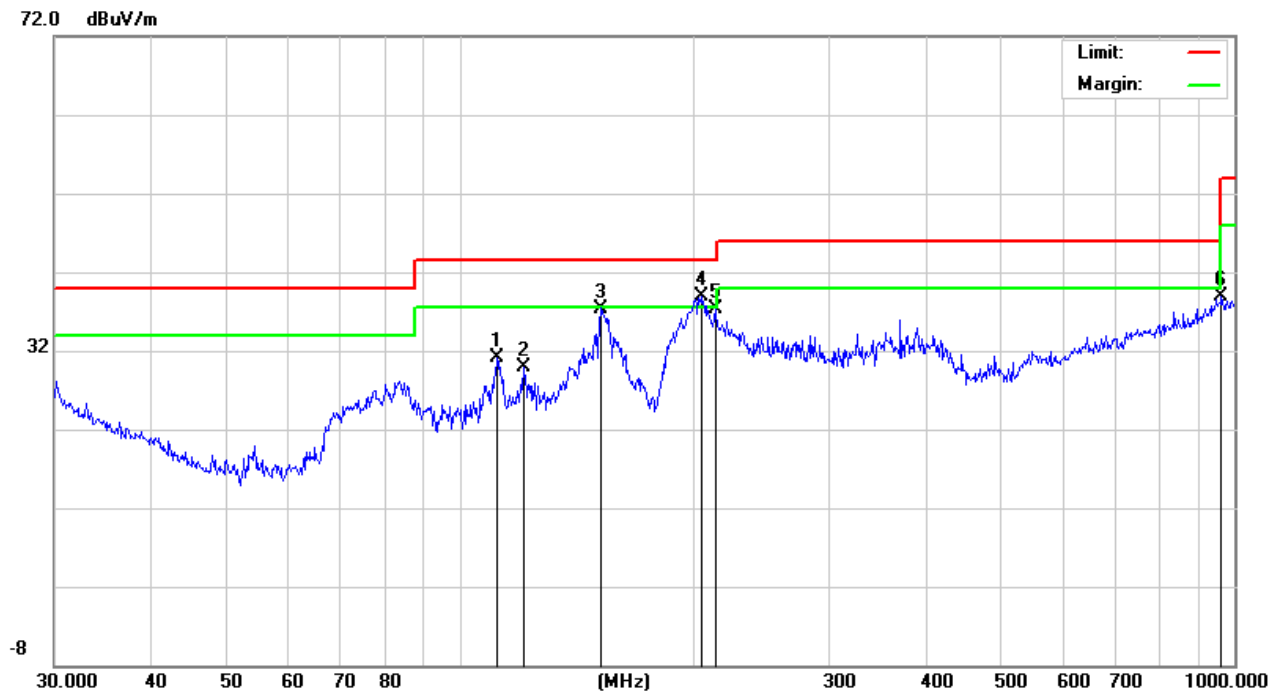

EUT :	Nebula Mars	Model Name :	D2311
Temperature :	20 °C	Relative Humidity :	48%
Pressure :	1010 hPa	Test Voltage :	DC 11.4V
Test Mode :	TX(5.8G) - 802.11a (High CH)		

Polar (H/V)	Frequency	Meter Reading	Factor	Emission Level	Limits	Margin	Remark
	(MHz)	(dBuV)	(dB)	(dBuV/m)	(dBuV/m)	(dB)	
V	39.2991	18.44	15.36	33.8	40	-6.2	QP
V	53.8817	27.38	7.45	34.83	40	-5.17	QP
V	69.6003	26.05	7.32	33.37	40	-6.63	QP
V	105.2716	23.74	12.26	36	43.5	-7.5	QP
V	144.8418	25.72	12.98	38.7	43.5	-4.8	QP
V	228.4901	24.76	12.24	37	46	-9	QP

Remark:

Absolute Level= ReadingLevel+ Factor, Margin= Absolute Level - Limit

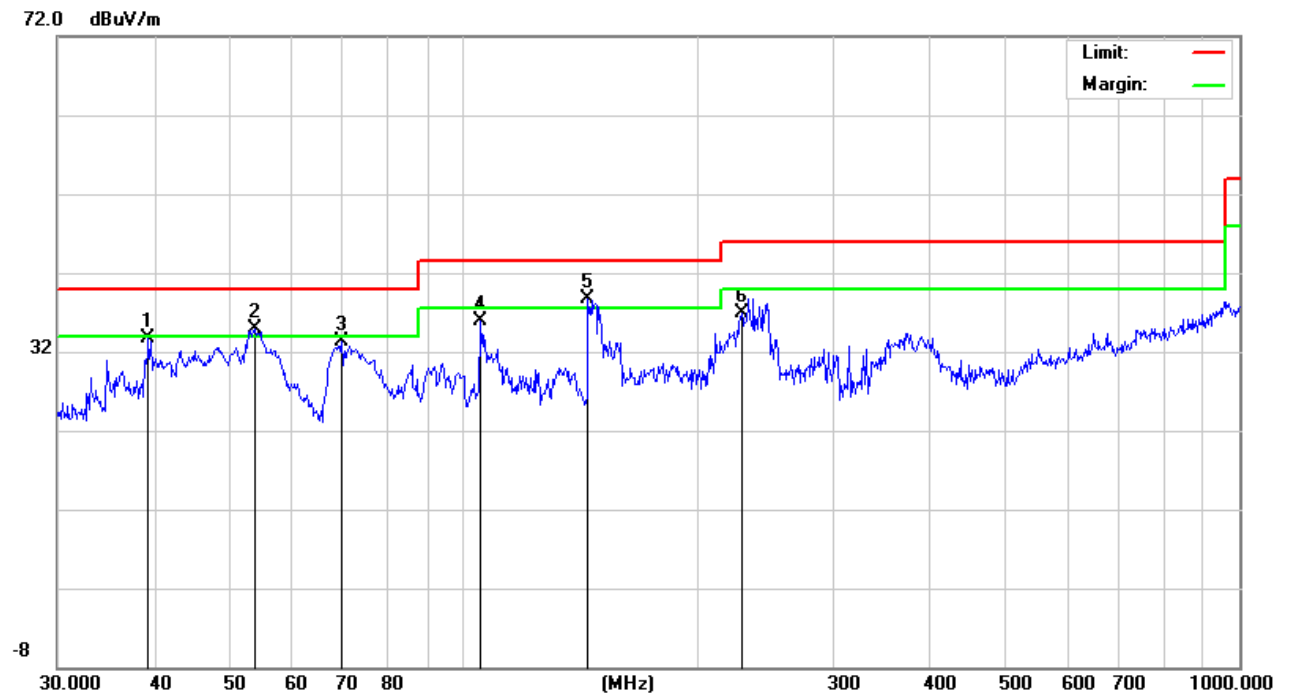

Polar (H/V)	Frequency	Meter Reading	Factor	Emission Level	Limits	Margin	Remark
	(MHz)	(dBuV)	(dB)	(dBuV/m)	(dBuV/m)	(dB)	
H	83.8156	18.85	9.27	28.12	40	-11.88	QP
H	111.7377	18.21	12.82	31.03	43.5	-12.47	QP
H	152.1297	24.58	12.88	37.46	43.5	-6.04	QP
H	204.955	28.22	10.74	38.96	43.5	-4.54	QP
H	370.7022	17.02	18.81	35.83	46	-10.17	QP
H	724.2611	7.66	26.57	34.23	46	-11.77	QP
H	962.1621	7.65	31.33	38.98	54	-15.02	QP

Remark:

Absolute Level= ReadingLevel+ Factor, Margin= Absolute Level - Limit

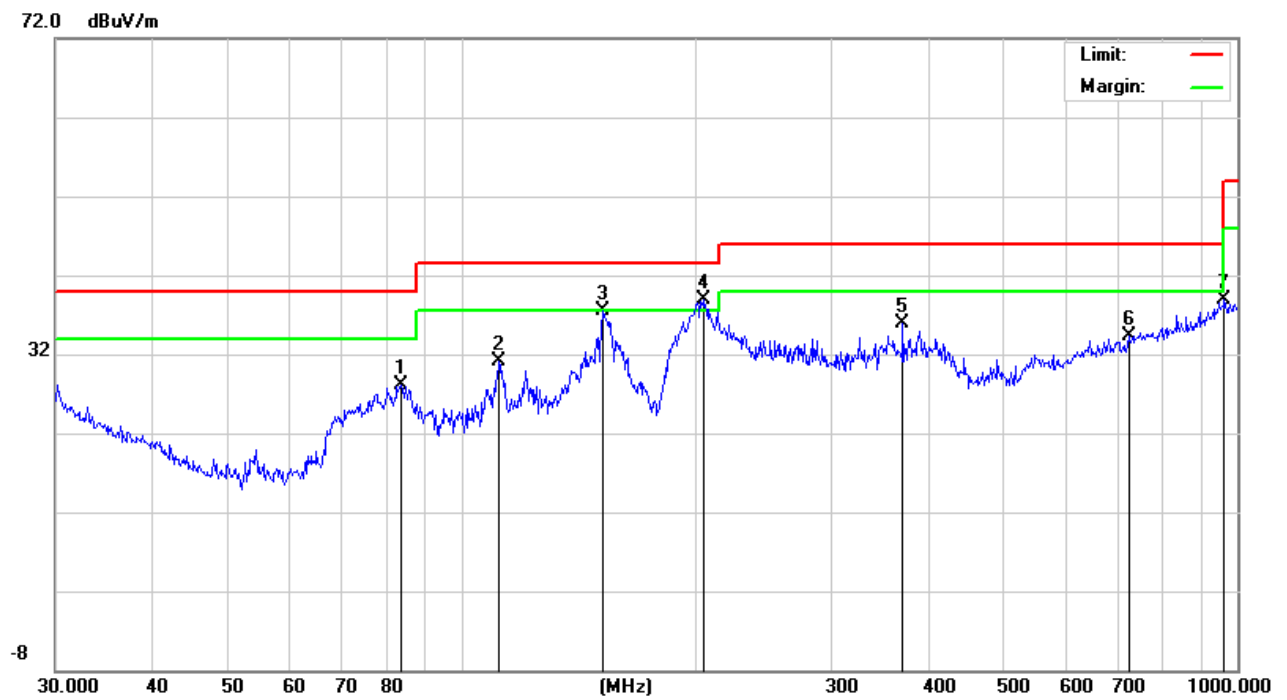

3.2.8 TEST RESULTS (1GHz-18GHz)

EUT :	Nebula Mars	Model Name :	D2311
Temperature :	20 °C	Relative Humidity :	48%
Pressure :	1010 hPa	Test Voltage :	DC 11.4V
Test Mode :	TX (5.2G)-802.11a 5180MHz~5240MHz		

Polar	Frequency	Meter Reading	Cable loss	Antenna Factor	Preamp Factor	Emission Level	Limits	Margin	Detector Type
(H/V)	(MHz)	(dBuV)	(dB)	dB/m	(dB)	(dBuV/m)	(dBuV/m)	(dB)	
Low Channel (5180 MHz)-Above 1G									
Vertical	4434.177	62.26	5.94	35.4	44	59.6	74	-14.4	Pk
Vertical	4434.177	46.61	5.94	35.4	44	43.95	54	-10.05	AV
Vertical	10370.38	60.45	8.46	39.75	44.5	64.16	74	-9.84	Pk
Vertical	10370.38	42.98	8.46	39.75	44.5	46.69	54	-7.31	AV
Vertical	15540.22	61.52	10.12	38.8	44.1	66.34	74	-7.66	Pk
Vertical	15540.22	37.6	10.12	38.8	42.7	43.82	54	-10.18	AV
Horizontal	4434.541	66.63	5.94	35.18	44	63.75	74	-10.25	Pk
Horizontal	4434.541	44.15	5.94	35.18	44	41.27	54	-12.73	AV
Horizontal	10370.64	59.01	8.46	38.71	44.5	61.68	74	-12.32	Pk
Horizontal	10370.64	41.07	8.46	38.71	44.5	43.74	54	-10.26	AV
Horizontal	10540.89	57	10.12	38.38	44.1	61.4	74	-12.6	Pk
Horizontal	10540.89	38.92	10.12	38.38	44.1	43.32	54	-10.68	AV
middle Channel (5200 MHz)-Above 1G									
Vertical	4592.113	60.29	6.48	36.35	44.05	59.07	74	-14.93	Pk
Vertical	4592.113	41.95	6.48	36.35	44.05	40.73	54	-13.27	AV
Vertical	10401.44	59.72	8.47	37.88	44.51	61.56	74	-12.44	Pk
Vertical	10401.44	42.78	8.47	37.88	44.51	44.62	54	-9.38	AV
Vertical	15600.24	56.56	10.12	38.8	44.1	61.38	74	-12.62	Pk
Vertical	15600.24	36.68	10.12	38.8	42.7	42.9	54	-11.1	AV
Horizontal	4592.711	59.9	6.48	36.37	44.05	58.7	74	-15.3	Pk
Horizontal	4592.711	43.15	6.48	36.37	44.05	41.95	54	-12.05	AV
Horizontal	10400.13	58.91	8.47	38.64	44.5	61.52	74	-12.48	Pk
Horizontal	10400.13	42.28	8.47	38.64	44.5	44.89	54	-9.11	AV
Horizontal	15600.21	59.9	10.12	38.38	44.1	64.3	74	-9.7	Pk
Horizontal	15600.21	38.82	10.12	38.38	44.1	43.22	54	-10.78	AV
High Channel (5240 MHz)-Above 1G									
Vertical	4739.266	61.27	7.1	37.24	43.5	62.11	74	-11.89	Pk
Vertical	4739.266	44.45	7.1	37.24	43.5	45.29	54	-8.71	AV
Vertical	10480.39	60.56	8.46	37.68	44.5	62.2	74	-11.8	Pk
Vertical	10480.39	40.36	8.46	37.68	44.5	42	54	-12	AV
Vertical	15720.38	61.78	10.12	38.8	44.1	66.6	74	-7.4	Pk
Vertical	15720.38	39.72	10.12	38.8	42.7	45.94	54	-8.06	AV
Horizontal	4739.372	62.28	7.1	37.24	43.5	63.12	74	-10.88	Pk
Horizontal	4739.372	43.31	7.1	37.24	43.5	44.15	54	-9.85	AV
Horizontal	10481.13	62.61	8.46	38.57	44.5	65.14	74	-8.86	Pk
Horizontal	10481.13	43.36	8.46	38.57	44.5	45.89	54	-8.11	AV
Horizontal	15720.38	60.78	10.12	38.38	44.1	65.18	74	-8.82	Pk
Horizontal	15720.38	42.3	10.12	38.38	44.1	46.7	54	-7.3	AV

Note: "802.11a (5G)" mode is the worst mode. PK value is lower than the Average value limit, So average didn't record.

The amplitude of spurious emissions that are attenuated by more than 20dB below the permissible value has no need to be reported.

Emission level (dBuV/m) = 20 log Emission Level (uV/m).

Corrected Reading: Antenna Factor + Cable Loss + Read Level - Preamp Factor = Level.

EUT :	Nebula Mars	Model Name :	D2311
Temperature :	20 °C	Relative Humidity :	48%
Pressure :	1010 hPa	Test Voltage :	DC 11.4V
Test Mode :	TX (5.8G) -a 5745MHz~5825MHz		

Polar	Frequency	Meter Reading	Cable loss	Antenna Factor	Preamp Factor	Emission Level	Limits	Margin	Detector Type
(H/V)	(MHz)	(dBuV)	(dB)	dB/m	(dB)	(dBuV/m)	(dBuV/m)	(dB)	
Low Channel (5745 MHz)-Above 1G									
Vertical	4679.225	52.46	5.94	35.4	44	49.8	74	-24.2	Pk
Vertical	4679.225	45.3	5.94	35.4	44	42.64	54	-11.36	AV
Vertical	11490.582	60.2	8.46	39.75	44.5	63.91	74	-10.09	Pk
Vertical	11490.582	44.27	8.46	39.75	44.5	47.98	54	-6.02	AV
Vertical	17235.746	56.46	10.12	38.8	44.1	61.28	74	-12.72	Pk
Vertical	17235.746	40.28	10.12	38.8	42.7	46.5	54	-7.5	AV
Horizontal	4679.184	57.4	5.94	35.18	44	54.52	74	-19.48	Pk
Horizontal	4679.184	44.31	5.94	35.18	44	41.43	54	-12.57	AV
Horizontal	11490.179	59.52	8.46	38.71	44.5	62.19	74	-11.81	Pk
Horizontal	11490.179	44.39	8.46	38.71	44.5	47.06	54	-6.94	AV
Horizontal	17235.546	58.27	10.12	38.38	44.1	62.67	74	-11.33	Pk
Horizontal	17235.546	42.5	10.12	38.38	44.1	46.9	54	-7.1	AV
middle Channel (5785 MHz)-Above 1G									
Vertical	4592.177	58.62	6.48	36.35	44.05	57.4	74	-16.6	Pk
Vertical	4592.177	43.28	6.48	36.35	44.05	42.06	54	-11.94	AV
Vertical	11570.204	59.85	8.47	37.88	44.51	61.69	74	-12.31	Pk
Vertical	11570.204	43.88	8.47	37.88	44.51	45.72	54	-8.28	AV
Vertical	17355.26	57.27	10.12	38.8	44.1	62.09	74	-11.91	Pk
Vertical	17355.26	40.3	10.12	38.8	42.7	46.52	54	-7.48	AV
Horizontal	4592.505	59.8	6.48	36.37	44.05	58.6	74	-15.4	Pk
Horizontal	4592.505	43.38	6.48	36.37	44.05	42.18	54	-11.82	AV
Horizontal	11570.284	60.56	8.47	38.64	44.5	63.17	74	-10.83	Pk
Horizontal	11570.284	46.31	8.47	38.64	44.5	48.92	54	-5.08	AV
Horizontal	17355.784	59.73	10.12	38.38	44.1	64.13	74	-9.87	Pk
Horizontal	17355.784	44.39	10.12	38.38	44.1	48.79	54	-5.21	AV
High Channel (5825 MHz)-Above 1G									
Vertical	5039.144	58.79	7.1	37.24	43.5	59.63	74	-14.37	Pk
Vertical	5039.144	46.49	7.1	37.24	43.5	47.33	54	-6.67	AV
Vertical	11650.284	55.4	8.46	37.68	44.5	57.04	74	-16.96	Pk
Vertical	11650.284	42.26	8.46	37.68	44.5	43.9	54	-10.1	AV
Vertical	17475.427	59.51	10.12	38.8	44.1	64.33	74	-9.67	Pk
Vertical	17475.427	39.96	10.12	38.8	42.7	46.18	54	-7.82	AV
Horizontal	5039.28	66.69	7.1	37.24	43.5	67.53	74	-6.47	Pk
Horizontal	5039.28	42.31	7.1	37.24	43.5	43.15	54	-10.85	AV
Horizontal	11650.174	56.6	8.46	38.57	44.5	59.13	74	-14.87	Pk
Horizontal	11650.174	43.79	8.46	38.57	44.5	46.32	54	-7.68	AV
Horizontal	17475.309	59.88	10.12	38.38	44.1	64.28	74	-9.72	Pk
Horizontal	17475.309	44.36	10.12	38.38	44.1	48.76	54	-5.24	AV

Note: "802.11a (5G)" mode is the worst mode. PK value is lower than the Average value limit, So average didn't record.

The amplitude of spurious emissions that are attenuated by more than 20dB below the permissible value has no need to be reported.

Emission level (dBuV/m) = 20 log Emission Level (uV/m).

Corrected Reading: Antenna Factor + Cable Loss + Read Level - Preamp Factor = Level.

TEST RESULTS (18GHz-40GHz)

EUT :	Nebula Mars	Model Name :	D2311
Temperature :	20 °C	Relative Humidity :	48%
Pressure :	1010 hPa	Test Voltage :	DC 11.4V
Test Mode :	TX (5.2G)-802.11a 5180MHz~5240MHz , TX (5.8G) -802.11a 5745MHz~5825MHz		

All the modulation modes have been tested, and the worst result was report as below:
Channel (5180 MHz) 18-26.5G

Horizontal

FCC Electric Field Strength 18-26.5GHz

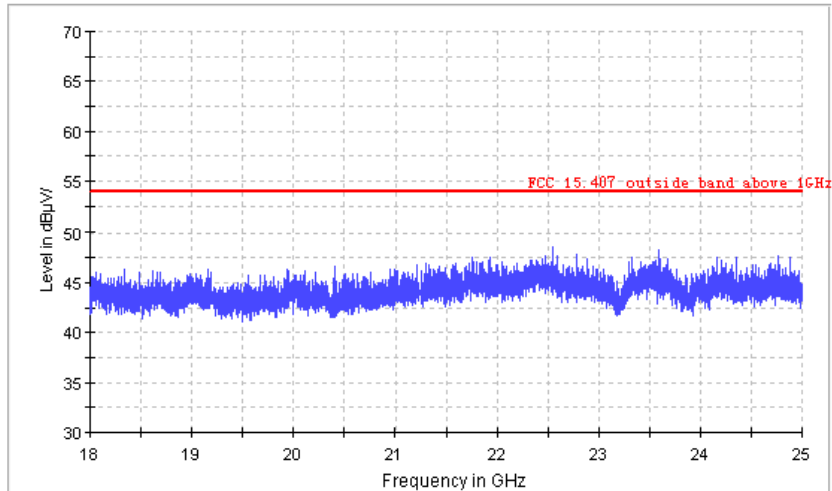

Vertical

FCC Electric Field Strength 18-26.5GHz

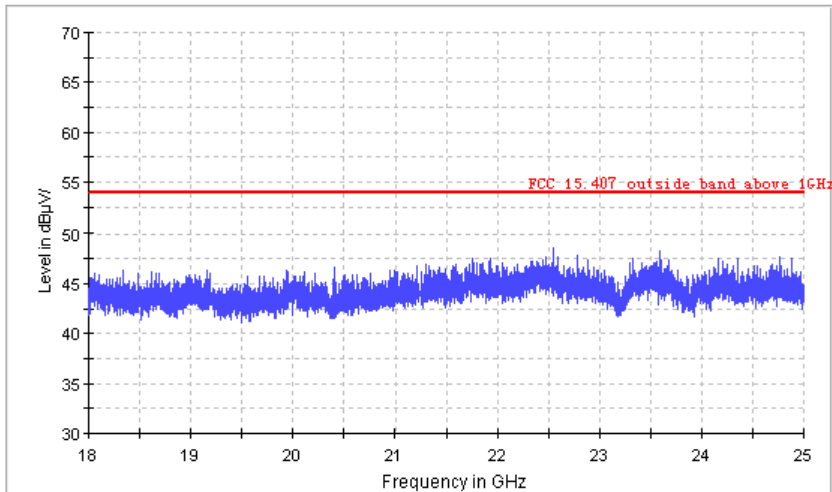

Channel (5180 MHz) 26.5-40G

Horizontal

FCC Electric Field Strength 26.5-40GHz

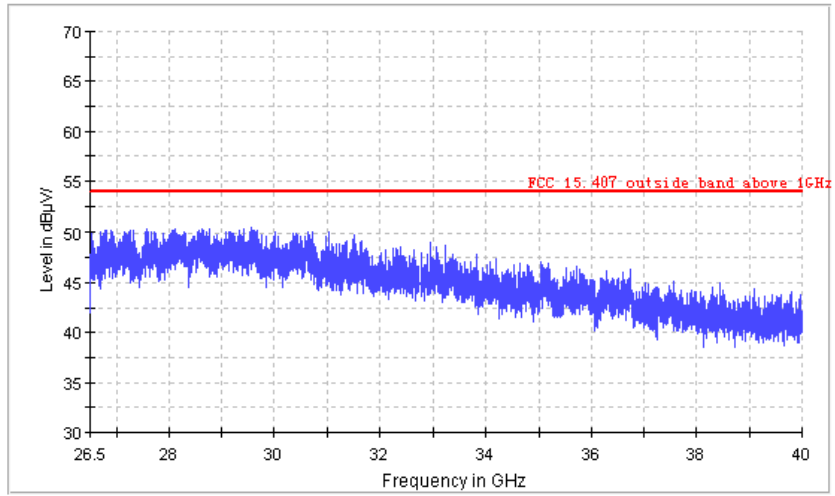

Vertical

FCC Electric Field Strength 26.5-40GHz

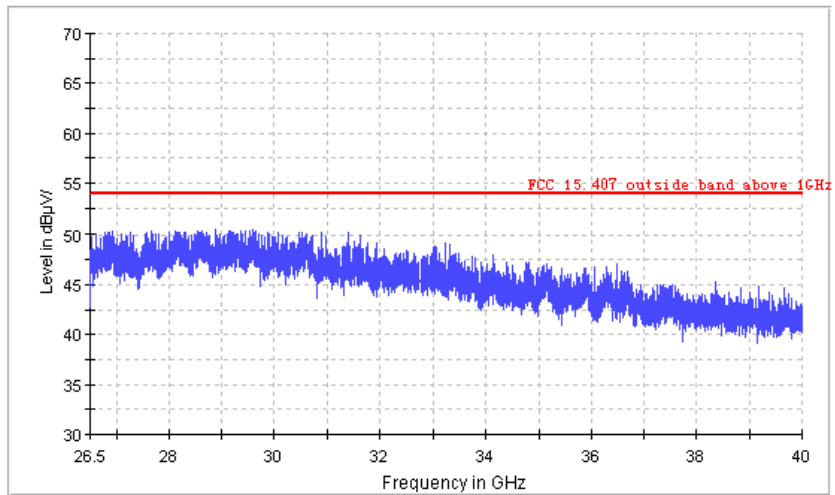

Channel (5745 MHz) 18-26.5G

Horizontal

FCC Electric Field Strength 18-26.5GHz

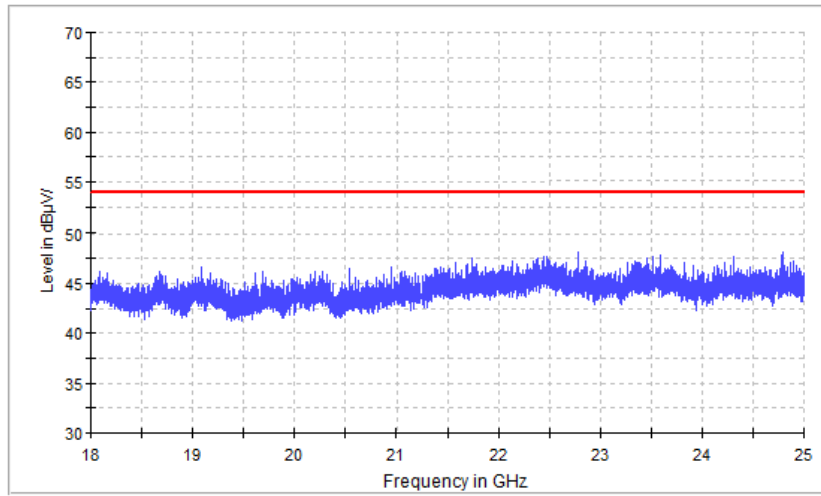

Vertical

FCC Electric Field Strength 18-26.5GHz

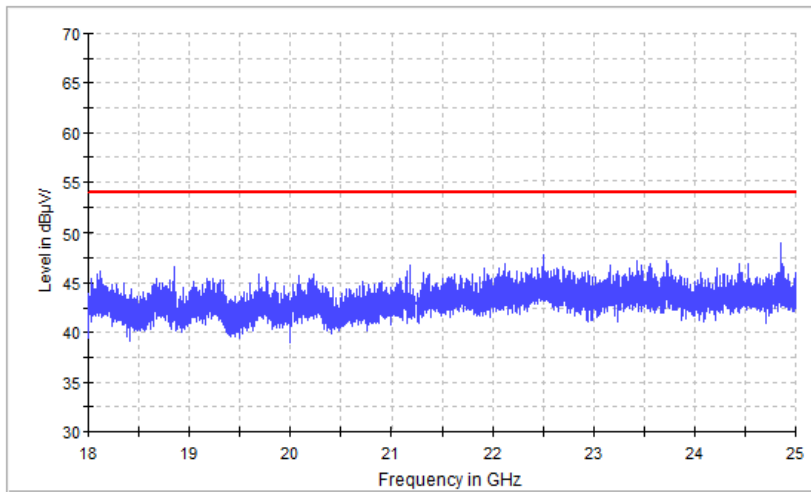

Channel (5745 MHz) 26.5-40G

Horizontal

FCC Electric Field Strength 26.5-40GHz

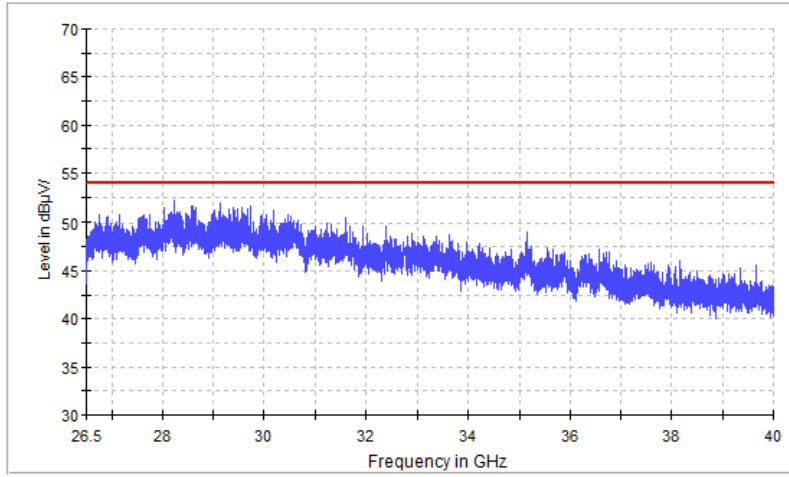

Vertical

FCC Electric Field Strength 26.5-40GHz

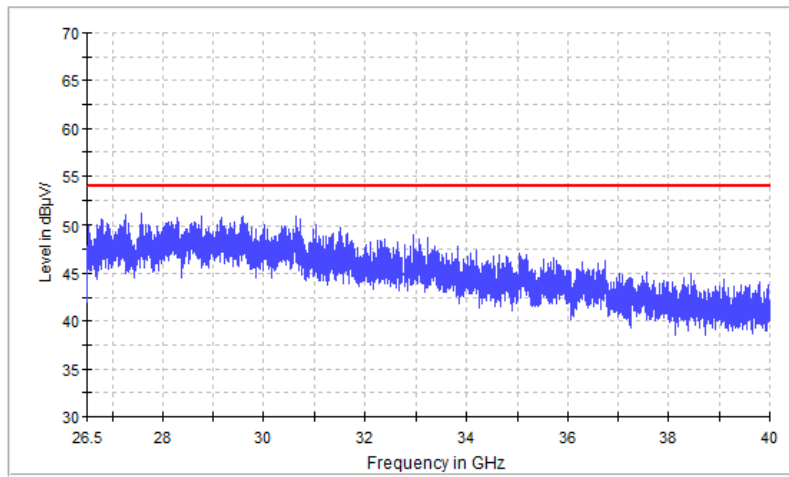

4. POWER SPECTRAL DENSITY TEST

4.1 APPLIED PROCEDURES / LIMIT

According to FCC §15.407(a)(3)

For the band 5.15-5.25 GHz,

(i) For an outdoor access point operating in the band 5.15-5.25 GHz, the maximum power spectral density shall not exceed 17 dBm in any 1 megahertz band. If transmitting antennas of directional gain greater than 6 dBi are used, both the maximum conducted output power and the maximum power spectral density shall be reduced by the amount in dB that the directional gain of the antenna exceeds 6 dBi. The maximum e.i.r.p. at any elevation angle above 30 degrees as measured from the horizon must not exceed 125 mW (21 dBm).

(ii) For an indoor access point operating in the band 5.15-5.25 GHz, the maximum power spectral density shall not exceed 17 dBm in any 1 megahertz band. If transmitting antennas of directional gain greater than 6 dBi are used, both the maximum conducted output power and the maximum power spectral density shall be reduced by the amount in dB that the directional gain of the antenna exceeds 6 dBi.

(iii) For fixed point-to-point access points operating in the band 5.15-5.25 GHz, the maximum power spectral density shall not exceed 17 dBm in any 1 megahertz band. Fixed point-to-point U-NII devices may employ antennas with directional gain up to 23 dBi without any corresponding reduction in the maximum conducted output power or maximum power spectral density. For fixed point-to-point transmitters that employ a directional antenna gain greater than 23 dBi, a 1 dB reduction in maximum conducted output power and maximum power spectral density is required for each 1 dB of antenna gain in excess of 23 dBi. Fixed, point-to-point operations exclude the use of point-to-multipoint systems, omnidirectional applications, and multiple collocated transmitters transmitting the same information. The operator of the U-NII device, or if the equipment is professionally installed, the installer, is responsible for ensuring that systems employing high gain directional antennas are used exclusively for fixed, point-to-point operations.

(iv) For mobile and portable client devices in the 5.15-5.25 GHz band, the maximum power spectral density shall not exceed 11 dBm in any 1 megahertz band. If transmitting antennas of directional gain greater than 6 dBi are used, both the maximum conducted output power and the maximum power spectral density shall be reduced by the amount in dB that the directional gain of the antenna exceeds 6 dBi.

For the band 5.725-5.85 GHz

(3) For the band 5.725-5.85 GHz, the maximum power spectral density shall not exceed 30 dBm in any 500-kHz band. If transmitting antennas of directional gain greater than 6 dBi are used, both the maximum conducted output power and the maximum power spectral density shall be reduced by the amount in dB that the directional gain of the antenna exceeds 6 dBi.

4.2 TEST PROCEDURE

For devices operating in the bands 5.15-5.25 GHz, 5.25-5.35 GHz, and 5.47-5.725 GHz, the above procedures make use of 1 MHz RBW to satisfy directly the 1 MHz reference bandwidth specified in § 15.407(a)(5). For devices operating in the band 5.725-5.85 GHz, the rules specify a measurement bandwidth of 500 kHz. Many spectrum analyzers do not have 500 kHz RBW, thus a narrower RBW may need to be used. The rules permit the use of a RBWs less than 1 MHz, or 500 kHz, “provided that the measured power is integrated over the full reference bandwidth” to show the total power over the specified measurement bandwidth (i.e., 1 MHz, or 500 kHz). If measurements are performed using a reduced resolution bandwidth (< 1 MHz, or < 500 kHz) and integrated over 1 MHz, or 500 KHz bandwidth, the following adjustments to the procedures apply:

- a) Set $RBW \geq 1/T$, where T is defined in section II.B.1.a).
- b) Set $VBW \geq 3 RBW$.
- c) If measurement bandwidth of Maximum PSD is specified in 500 kHz, add $10\log(500\text{kHz}/RBW)$ to the measured result, whereas RBW (< 500 KHz) is the reduced resolution bandwidth of the spectrum analyzer set during measurement.
- d) If measurement bandwidth of Maximum PSD is specified in 1 MHz, add $10\log(1\text{MHz}/RBW)$ to the measured result, whereas RBW (< 1 MHz) is the reduced resolution bandwidth of spectrum analyzer set during measurement.
- e) Care must be taken to ensure that the measurements are performed during a period of continuous transmission or are corrected upward for duty cycle.

Note: As a practical matter, it is recommended to use reduced RBW of 100 KHz for the sections 5.c) and 5.d) above, since RBW=100 KHZ is available on nearly all spectrum analyzers.

4.3 DEVIATION FROM STANDARD

No deviation.

4.4 TEST SETUP

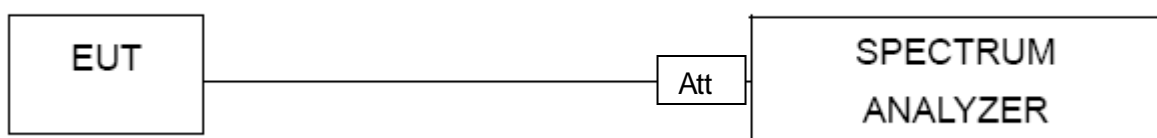

4.5 EUT OPERATION CONDITIONS

The EUT tested system was configured as the statements of 2.1 Unless otherwise a special operating condition is specified in the follows during the testing.

4.6 TEST RESULTS

EUT :	Nebula Mars	Model Name :	D2311
Temperature :	25 °C	Relative Humidity :	56%
Pressure :	1015 hPa	Test Voltage :	DC 11.4V
Test Mode :	TX Frequency (5150-5250MHz)		

Note: A(B) Represent the value of antenna A and B, The worst data is Antenna A ,only shown Antenna A Plot.

Mode	Frequency	Measured Power Density (dBm)	Measured Power Density(dBm)	Total Power Density (dBm)		Limit (dBm)	Result
		Antenna A	Antenna B	Antenna A	Antenna B		
802.11 a	5185 MHz	7.84	7.65	-	-	11	PASS
	5200 MHz	7.45	7.17	-	-	11	PASS
	5240 MHz	7.12	8.06	-	-	11	PASS
802.11 n20	5185 MHz	7.96	7.15	10.584		11	PASS
	5200 MHz	7.88	7.94	10.920		11	PASS
	5240 MHz	7.78	7.19	10.505		11	PASS
802.11 n40	5190 MHz	6.25	6.03	9.152		11	PASS
	5230 MHz	5.97	5.26	8.640		11	PASS

Note: 1.Calculate power density= Measured Power Density+10log(1MHz/RBW)

RBW=1MHz

Note: For 802.11n HT20/40 Directional gain=GANT +10log(N)dBi =1.26dBi

1.26dBi<6.0 dBi so Power Density limit= 11

(802.11 a) PSD plot on channel 36

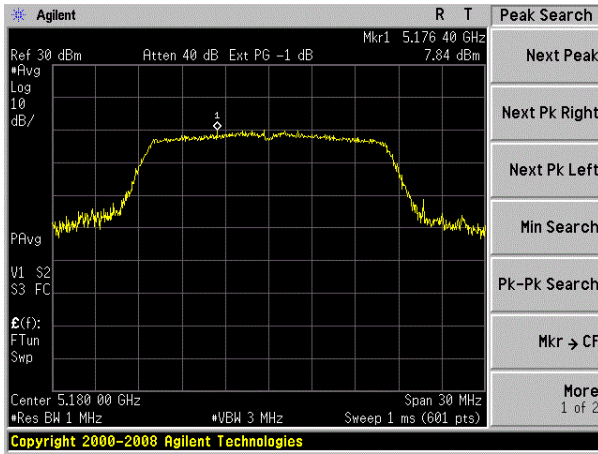

(802.11n20) PSD plot on channel 36

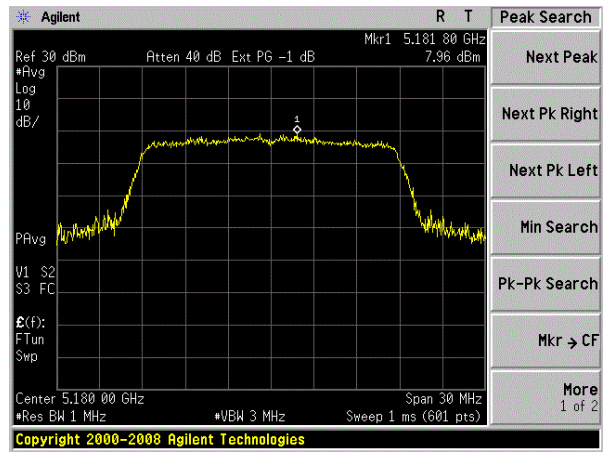

(802.11 a) PSD plot on channel 40

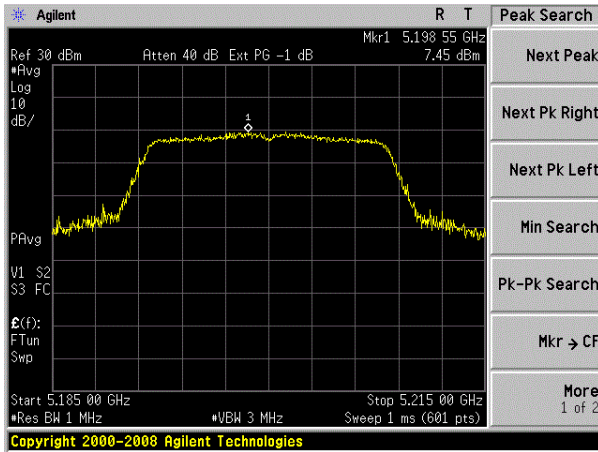

(802.11n20) PSD plot on channel 40

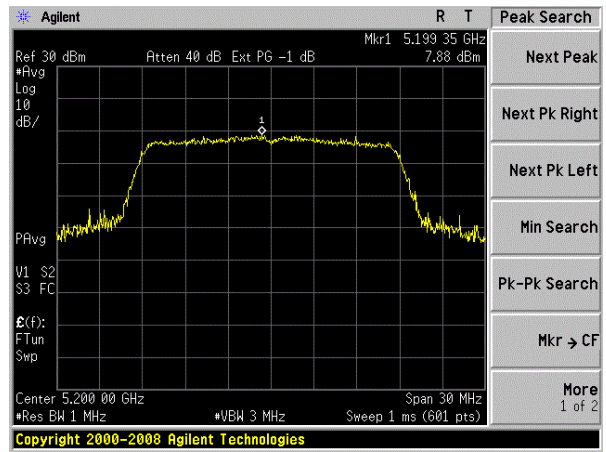

(802.11 a) PSD plot on channel 48

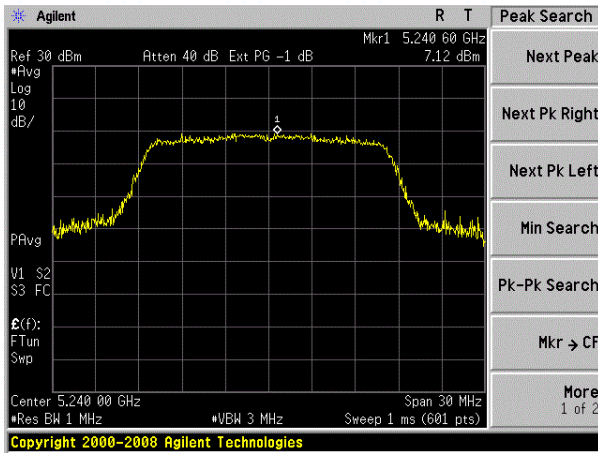

(802.11n20) PSD plot on channel 48

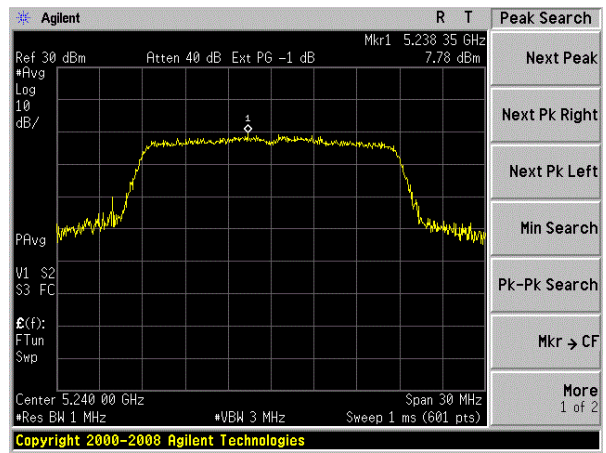

(802.11 n40) PSD plot on channel 38

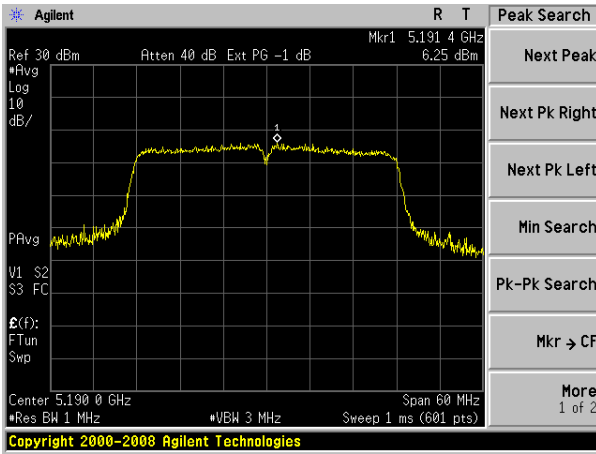

(802.11 n40) PSD plot on channel 46

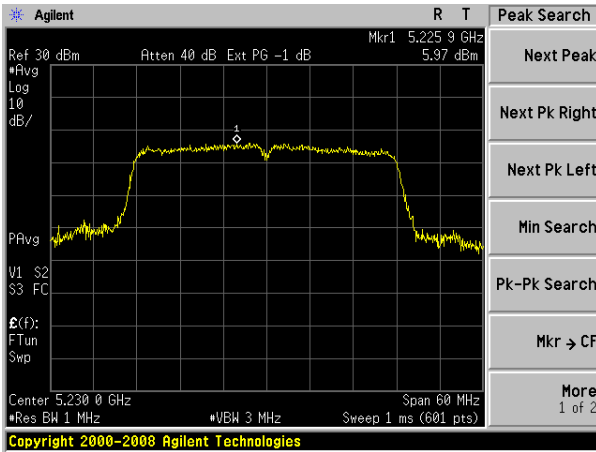

EUT :	Nebula Mars	Model Name :	D2311
Temperature :	25 °C	Relative Humidity :	56%
Pressure :	1015 hPa	Test Voltage :	DC 11.4V
Test Mode :	TX Frequency (5725-5825MHz)		

Note: A(B) Represent the value of antenna A and B, The worst data is Antenna A ,only shown Antenna A Plot.

Mode	Frequency	Measured Power Density (dBm)	Measured Power Density (dBm)	Factor (dBm)	Total Power Density (dBm)		Limit (dBm)	Result
		Antenna A	Antenna B		Antenna A	Antenna B		
802.11 a	5745 MHz	8.02	7.32	2.924	-	-	30	PASS
	5785 MHz	8.22	7.37	2.924	-	-	30	PASS
	5825 MHz	7.64	7.17	2.924	-	-	30	PASS
802.11 n20	5745 MHz	7.49	7.16	2.924	13.262		30	PASS
	5785 MHz	7.02	7.27	2.924	13.081		30	PASS
	5825 MHz	8.29	7.38	2.924	13.793		30	PASS
802.11 n40	5755 MHz	6.34	5.36	2.924	11.812		30	PASS
	5795 MHz	6.71	6.83	2.924	12.705		30	PASS

Note: 1. Calculate power density= Measured Power Density+10log(1MHz/RBW)

$$RBW=0.51MHz$$

Note: For 802.11n HT20/40 Directional gain=GANT +10log(N)dBi =1.26dBi
 1.26dBi<6.0 dBi so Power Density limit= 30

(802.11a) PSD plot on channel 149

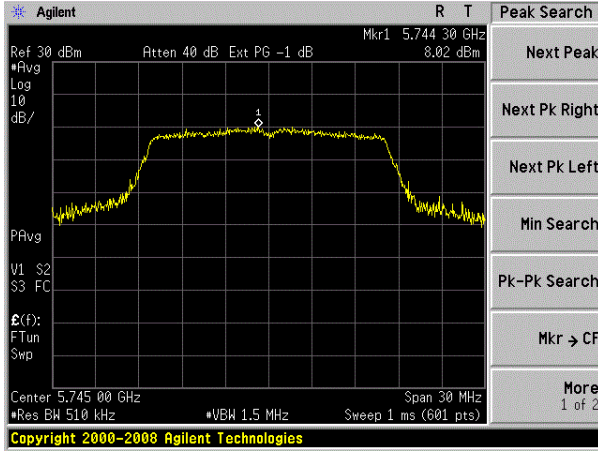

(802.11n20) PSD plot on channel 149

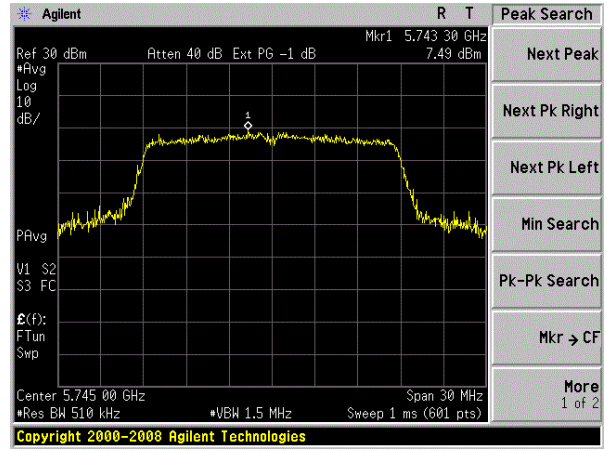

(802.11a) PSD plot on channel 157

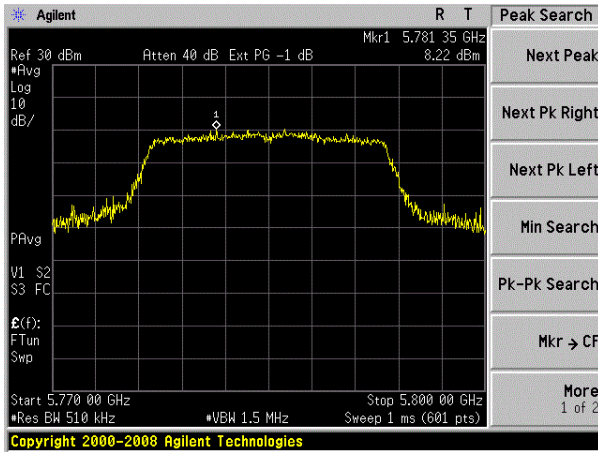

(802.11n20) PSD plot on channel 157

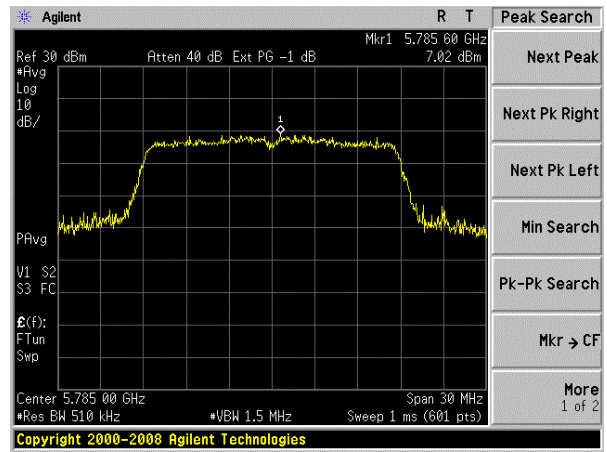

(802.11a) PSD plot on channel 165

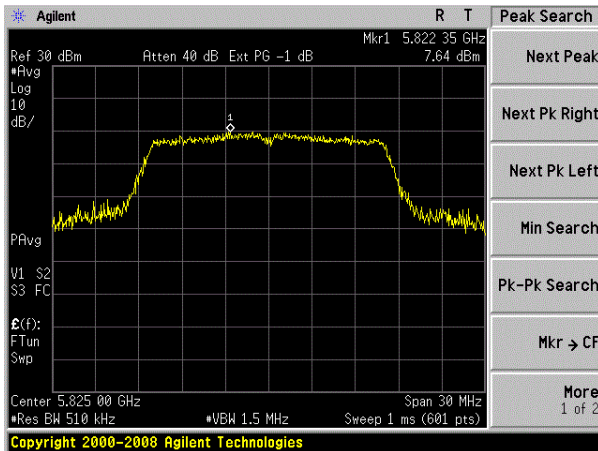

(802.11n20) PSD plot on channel 165

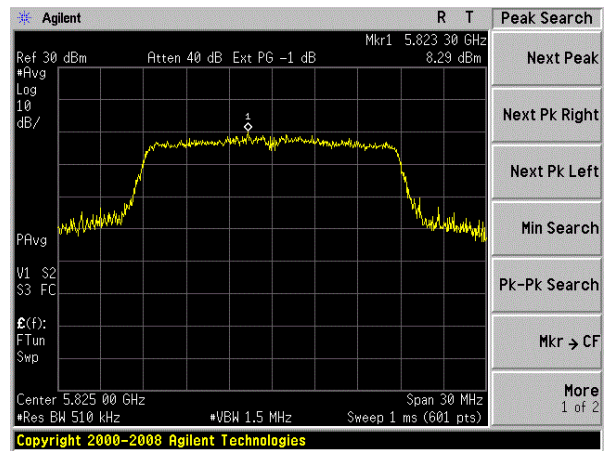

(802.11n40) PSD plot on channel 151

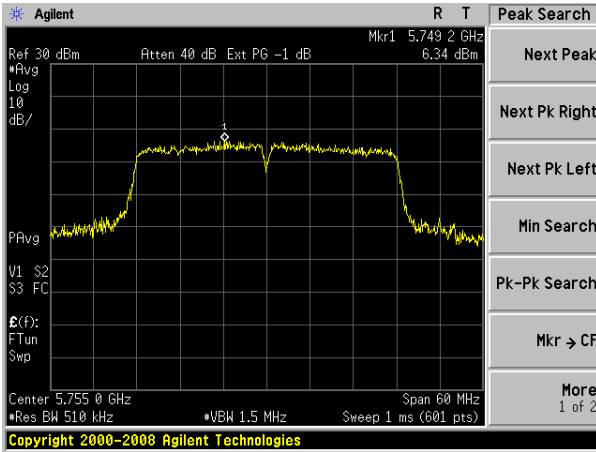

(802.11n40) PSD plot on channel 159

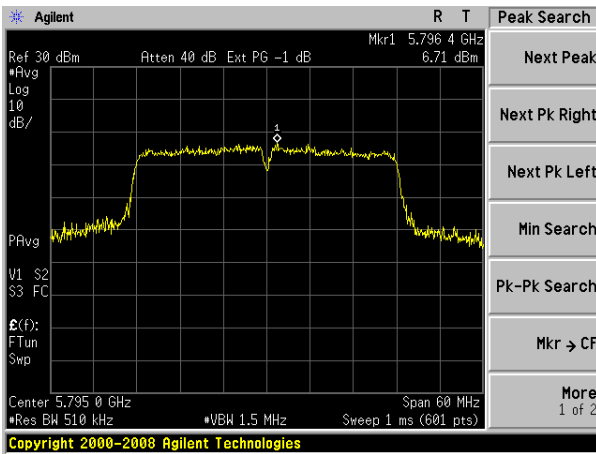

5. 26 DB & 99% EMISSION BANDWIDTH

5.1 APPLIED PROCEDURES / LIMIT

The maximum power spectral density is measured as a conducted emission by direct connection of a calibrated test instrument to the equipment under test. If the device cannot be connected directly, alternative techniques acceptable to the Commission may be used. Measurements in the 5.725-5.85 GHz band are made over a reference bandwidth of 500 kHz or the 26 dB emission bandwidth of the device, whichever is less. Measurements in the 5.15-5.25 GHz, 5.25-5.35 GHz, and the 5.47-5.725 GHz bands are made over a bandwidth of 1 MHz or the 26 dB emission bandwidth of the device, whichever is less. A narrower resolution bandwidth can be used, provided that the measured power is integrated over the full reference bandwidth.

5.2 TEST PROCEDURE

- a) Set RBW = approximately 1% of the emission bandwidth.
- b) Set the VBW > RBW.
- c) Detector = Peak.
- d) Trace mode = max hold.
- e) Measure the maximum width of the emission that is 26 dB down from the maximum of the emission. Compare this with the RBW setting of the analyzer. Readjust RBW and repeat measurement as needed until the RBW/EBW ratio is approximately 1%.

The following procedure shall be used for measuring (99 %) power bandwidth:

1. Set center frequency to the nominal EUT channel center frequency.
2. Set span = 1.5 times to 5.0 times the OBW.
3. Set RBW = 1 % to 5 % of the OBW
4. Set VBW $\geq 3 \cdot$ RBW
5. Video averaging is not permitted. Where practical, a sample detection and single sweep mode shall be used. Otherwise, peak detection and max hold mode (until the trace stabilizes) shall be used.
6. Use the 99 % power bandwidth function of the instrument (if available).
7. If the instrument does not have a 99 % power bandwidth function, the trace data points are recovered and directly summed in power units. The recovered amplitude data points, beginning at the lowest frequency, are placed in a running sum until 0.5 % of the total is reached; that frequency is recorded as the lower frequency. The process is repeated until 99.5 % of the total is reached; that frequency is recorded as the upper frequency. The 99% occupied bandwidth is the difference between these two frequencies.

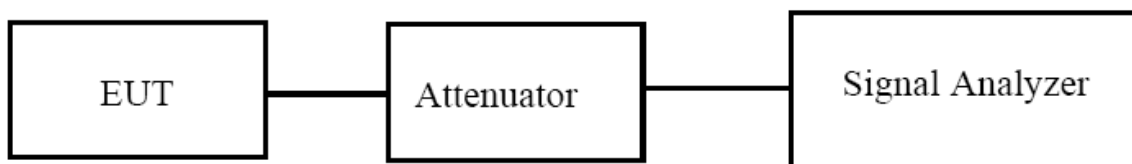

5.3 EUT OPERATION CONDITIONS

The EUT tested system was configured as the statements of 2.4 Unless otherwise a special operating condition is specified in the follows during the testing.

5.4 TEST RESULTS

EUT :	Nebula Mars	Model Name :	D2311
Temperature :	25 °C	Relative Humidity :	56%
Pressure :	1012 hPa	Test Voltage :	DC 11.4V
Test Mode :	TX Frequency (5150-5250MHz)		

Note: A(B) Represent the value of antenna A and B, The worst data is Antenna A, only shown Antenna A Plot.

Mode	Channel	Frequency (MHz)	99% bandwidth (MHz)	99% bandwidth (MHz)	26dB bandwidth (MHz)	26dB bandwidth (MHz)	Result
			Antenna A	Antenna B	Antenna A	Antenna B	
802.11a	CH36	5180	16.7107	16.8505	22.414	26.026	Pass
	CH40	5200	16.8457	16.8569	23.785	22.855	Pass
	CH48	5240	16.8659	16.8000	22.896	27.502	Pass
802.11 n20	CH36	5180	17.9472	17.7672	23.947	24.327	Pass
	CH40	5200	17.7185	17.7972	21.430	25.528	Pass
	CH48	5240	17.7293	17.7104	25.379	22.715	Pass
802.11 n40	CH 38	5190	35.9856	35.9421	40.135	40.319	Pass
	CH 46	5230	36.0179	36.0010	46.151	45.455	Pass

(802.11a) -26dB&99% Bandwidth plot on channel 36

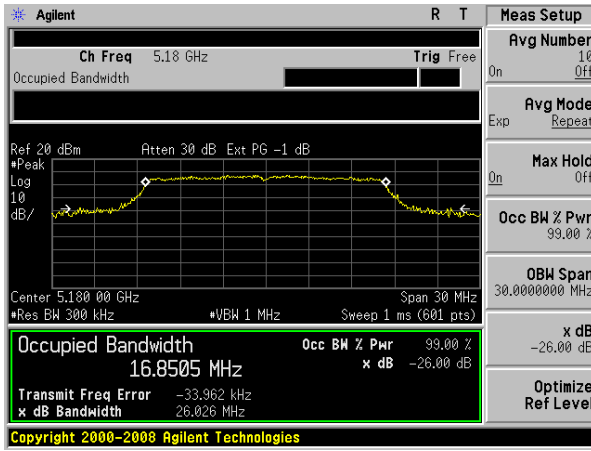

(802.11n20) -26dB&99% Bandwidth plot on channel 36

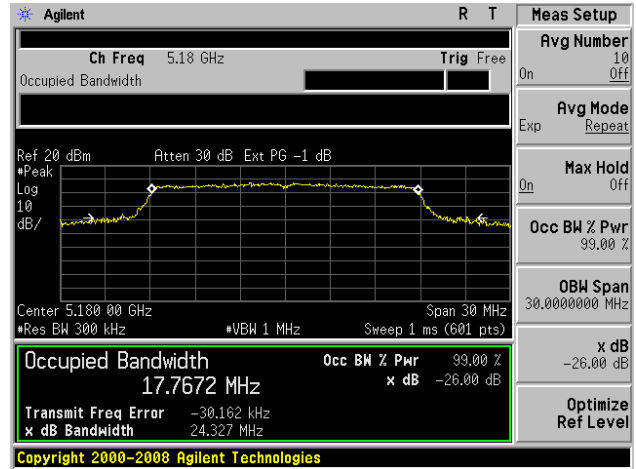

(802.11a) -26dB&99% Bandwidth plot on channel 40

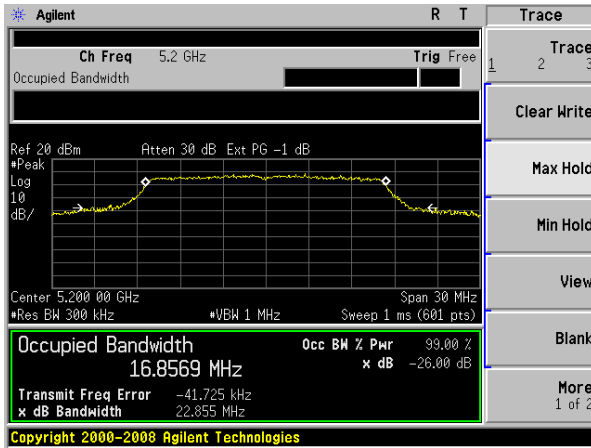

(802.11n20) -26dB&99% Bandwidth plot on channel 40

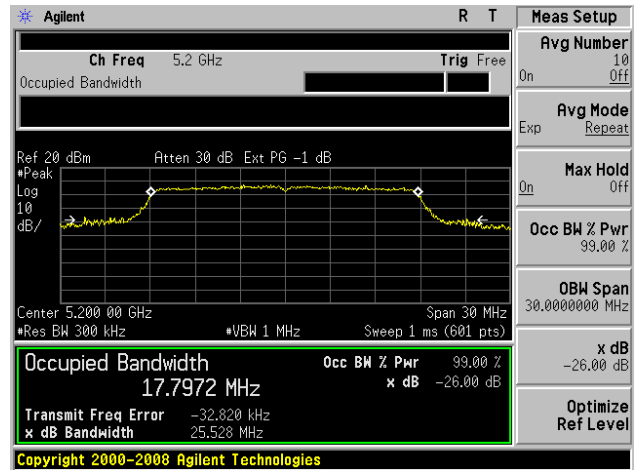

(802.11a) -26dB&99% Bandwidth plot on channel 48

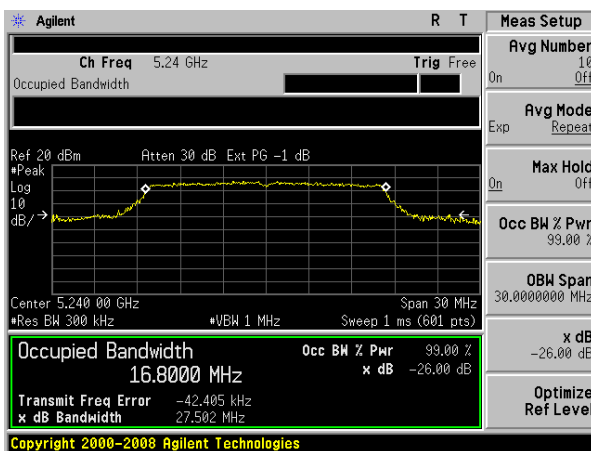

(802.11n20) -26dB&99% Bandwidth plot on channel 48

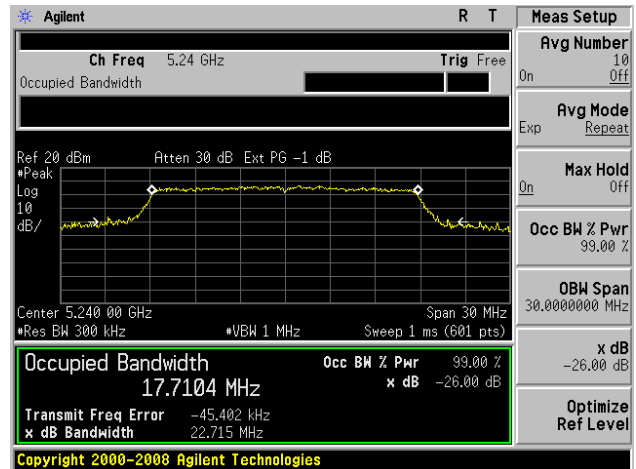

(802.11n40) -26dB&99% Bandwidth plot on channel 38

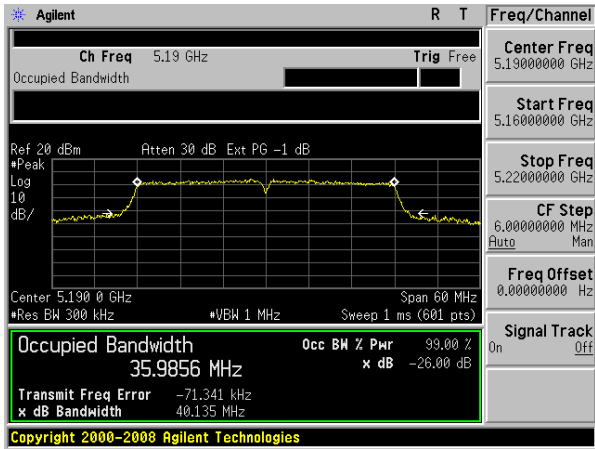

(802.11n40) -26dB&99% Bandwidth plot on channel 46

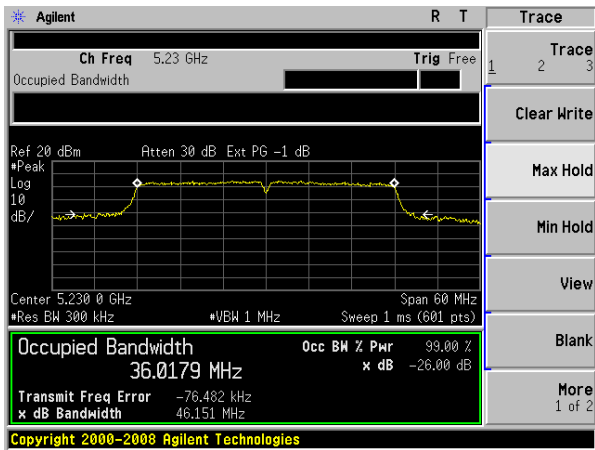

EUT :	Nebula Mars	Model Name :	D2311
Temperature :	25 °C	Relative Humidity :	56%
Pressure :	1012 hPa	Test Voltage :	DC 11.4V
Test Mode :	TX Frequency (5745-5850MHz)		

Note: A(B) Represent the value of antenna A and B, The worst data is Antenna A ,only shown Antenna A Plot.

Mode	Channel	Frequency (MHz)	99% bandwidth (MHz)	99% bandwidth (MHz)	26dB bandwidth (MHz)	26dB bandwidth (MHz)	Result
			Antenna A	Antenna B	Antenna A	Antenna B	
802.11a	CH149	5745	16.8577	16.9780	28.423	27.474	Pass
	CH157	5785	16.9925	16.0282	29.277	27.959	Pass
	CH165	5825	17.0414	16.9691	28.334	27.751	Pass
802.11 n20	CH149	5745	17.8016	17.7533	27.591	24.815	Pass
	CH157	5785	17.7892	17.7572	28.155	25.761	Pass
	CH165	5825	17.8182	17.7337	28.337	25.785	Pass
802.11 n40	CH151	5755	36.5547	36.4021	57.012	55.242	Pass
	CH159	5795	36.6693	36.5417	58.259	51.960	Pass

(802.11a) -26dB&99% Bandwidth plot on channel 149

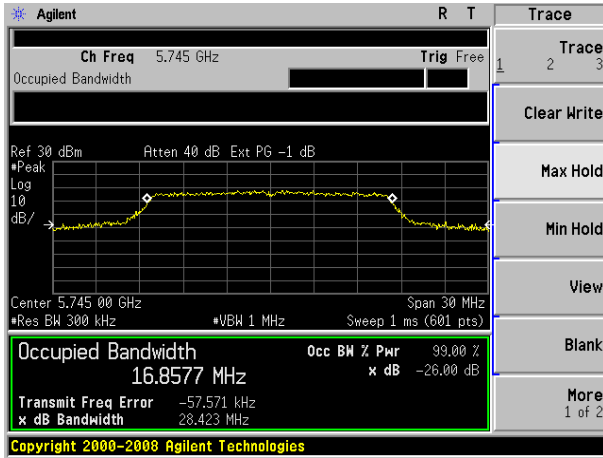

(802.11n20) -26dB&99% Bandwidth plot on channel 149

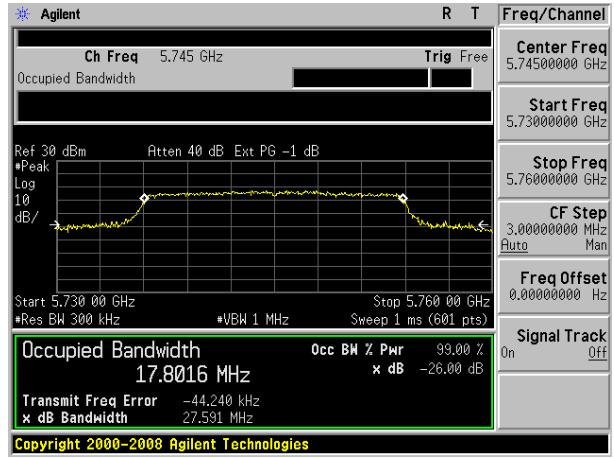

(802.11a) -26dB&99% Bandwidth plot on channel 157

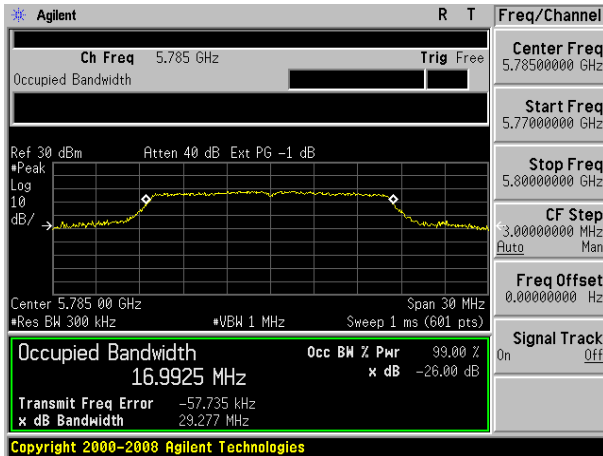

(802.11n20) -26dB&99% Bandwidth plot on channel 157

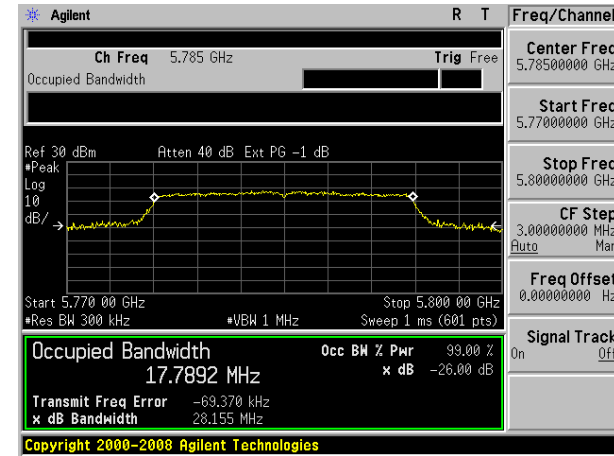

(802.11a) -26dB&99% Bandwidth plot on channel 165

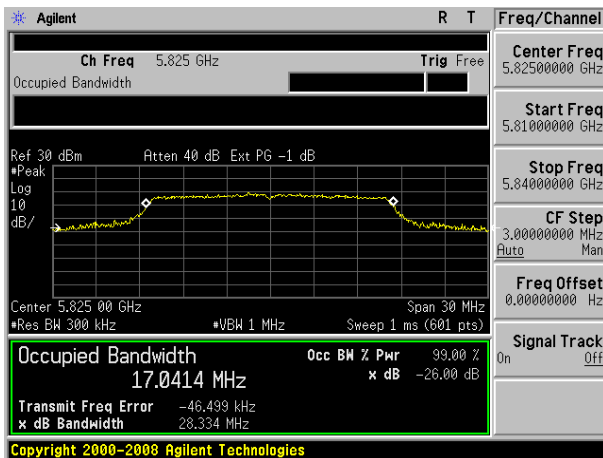

(802.11n20) -26dB&99% Bandwidth plot on channel 165

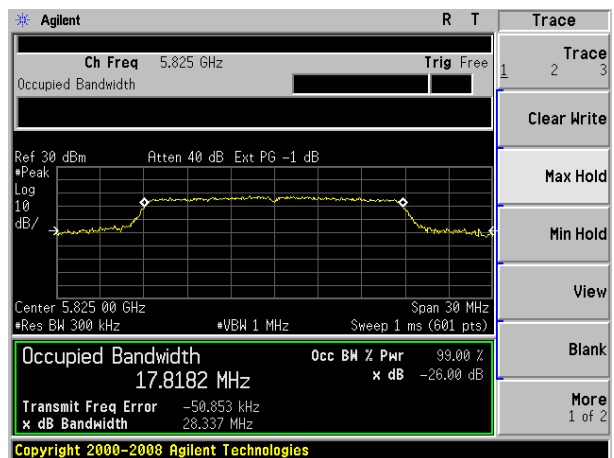

(802.11n40) -26dB&99% Bandwidth plot on channel 151

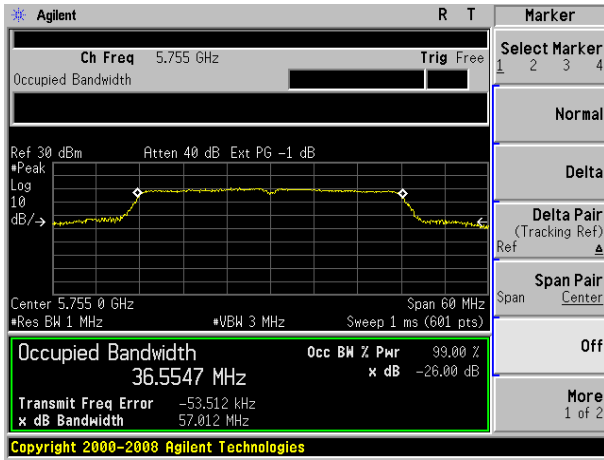

(802.11n40) -26dB&99% Bandwidth plot on channel 159

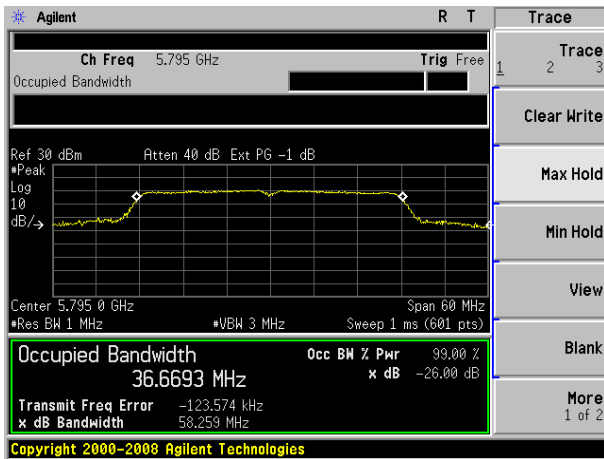

6. MINIMUM 6 DB BANDWIDTH

6.1 APPLIED PROCEDURES / LIMIT

According to FCC §15.407(e)

(e) Within the 5.725-5.85 GHz band, the minimum 6 dB bandwidth of U-NII devices shall be at least 500 kHz.

6.2 TEST PROCEDURE

Section 15.407(e) specifies the minimum 6 dB emission bandwidth of at least 500 KHz for the band 5.715-5.85 GHz. The following procedure shall be used for measuring this bandwidth:

- a) Set RBW = 100 kHz.
- b) Set the video bandwidth (VBW) $\geq 3 \times$ RBW.
- c) Detector = Peak.
- d) Trace mode = max hold.
- e) Sweep = auto couple.
- f) Allow the trace to stabilize.
- g) Measure the maximum width of the emission that is constrained by the frequencies associated with the two outermost amplitude points (upper and lower frequencies) that are attenuated by 6 dB relative to the maximum level measured in the fundamental emission.

6.3 DEVIATION FROM STANDARD

No deviation.

6.4 TEST SETUP

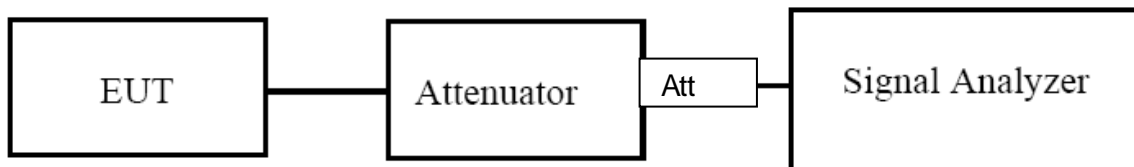

6.5 EUT OPERATION CONDITIONS

The EUT tested system was configured as the statements of 2.4 Unless otherwise a special operating condition is specified in the follows during the testing.

6.6 TEST RESULTS

EUT :	Nebula Mars	Model Name :	D2311
Temperature :	25 °C	Relative Humidity :	56%
Pressure :	1012 hPa	Test Voltage :	DC 11.4V
Test Mode :	TX Frequency (5150-5250MHz)		

Note: A(B) Represent the value of antenna A and B, The worst data is Antenna A ,only shown Antenna A Plot.

Mode	Channel	Frequency (MHz)	-6dB bandwidth (MHz)	-6dB bandwidth (MHz)	Result
			Antenna A	Antenna B	
802.11a	CH36	5180	16.320	16.378	Pass
	CH40	5200	16.321	16.003	Pass
	CH48	5240	15.933	16.313	Pass
802.11 n20	CH36	5180	16.231	16.666	Pass
	CH40	5200	16.559	16.673	Pass
	CH48	5240	17.122	17.323	Pass
802.11 n40	CH 38	5190	35.275	35.263	Pass
	CH 46	5230	35.246	35.257	Pass

(802.11a) -6dB Bandwidth plot on channel 36

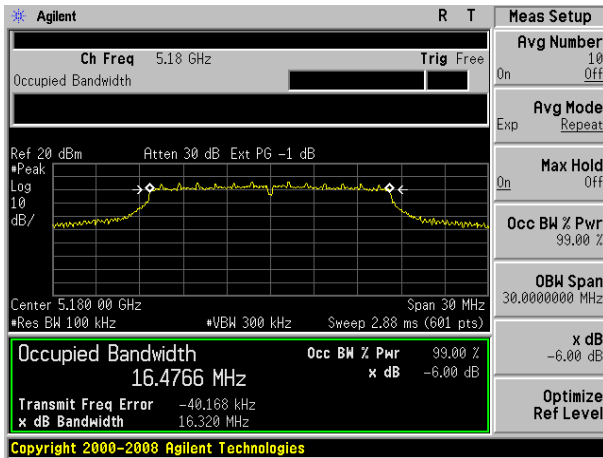

(802.11n20) -6dB Bandwidth plot on channel 36

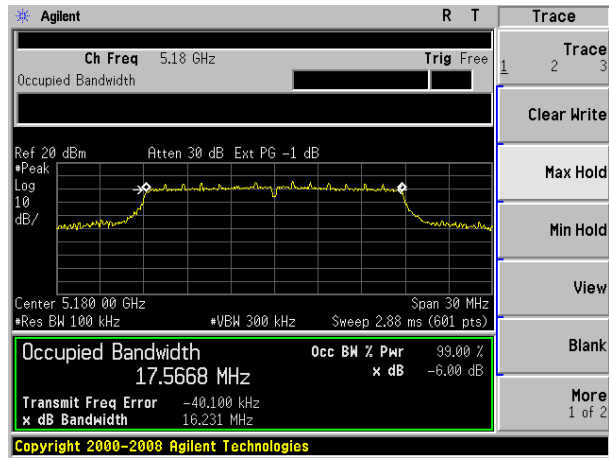

(802.11a) -6dB Bandwidth plot on channel 40

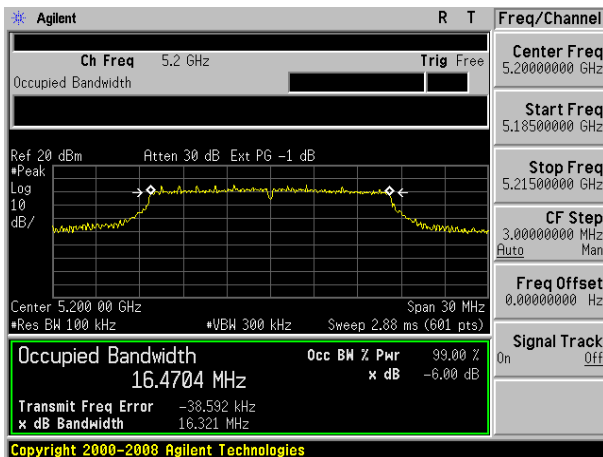

(802.11n20) -6dB Bandwidth plot on channel 40

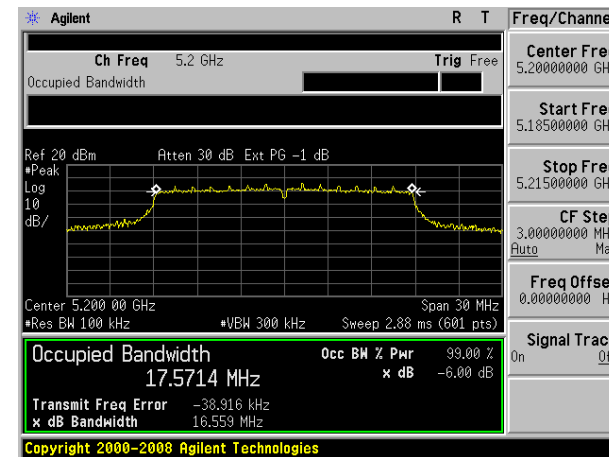

(802.11a) -6dB Bandwidth plot on channel 48

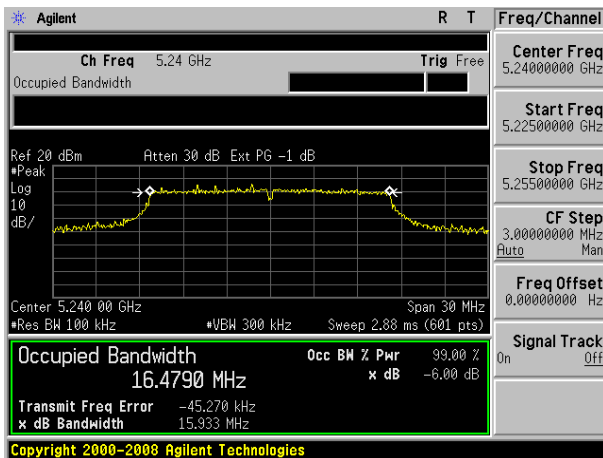

(802.11n20) -6dB Bandwidth plot on channel 48

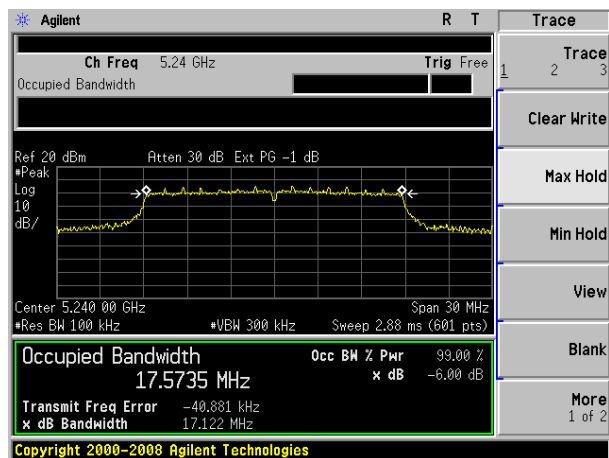

(802.11 n40) -6dB Bandwidth plot on channel 38

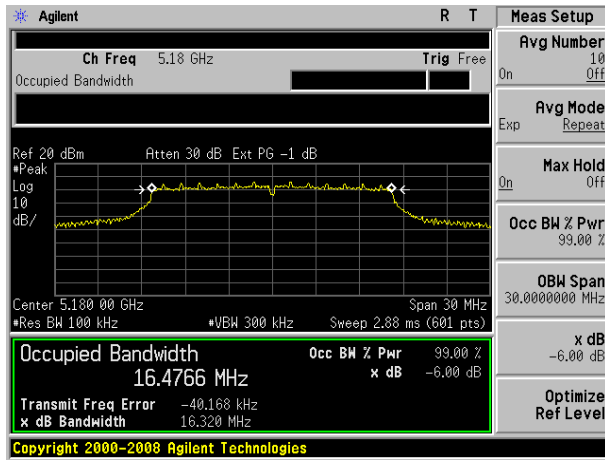

(802.11 n40) -6dB Bandwidth plot on channel 46

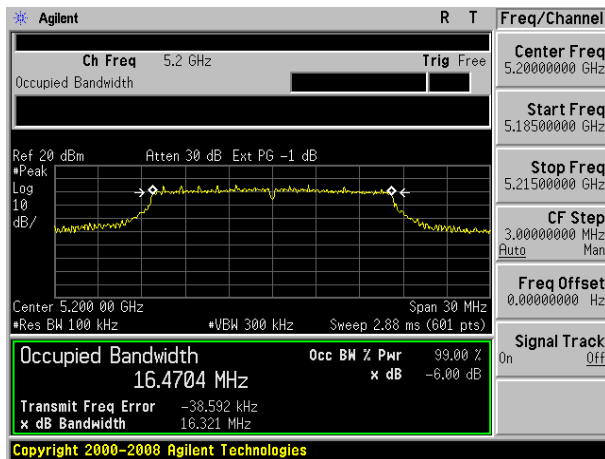

EUT :	Nebula Mars	Model Name :	D2311
Temperature :	25 °C	Relative Humidity :	60%
Pressure :	1012 hPa	Test Voltage :	DC 11.4V
Test Mode :	TX (5G) Mode Frequency (5725-5825MHz)		

Note: A(B) Represent the value of antenna A and B, The worst data is Antenna A ,only shown Antenna A Plot.

Mode	Channel	Frequency (MHz)	-6dB bandwidth (MHz)	-6dB bandwidth (MHz)	Limit (KHz)	Result
			Antenna A	Antenna B		
802.11a	149	5745	16.304	15.963	500	Pass
	157	5785	15.386	16.362	500	Pass
	165	5825	15.319	16.353	500	Pass
802.11 n20	149	5745	16.825	16.716	500	Pass
	157	5785	16.456	17.047	500	Pass
	165	5825	16.768	15.207	500	Pass
802.11 n40	151	5755	35.269	35.234	500	Pass
	159	5795	35.262	35.261	500	Pass

(802.11a) -6dB Bandwidth plot on channel 149

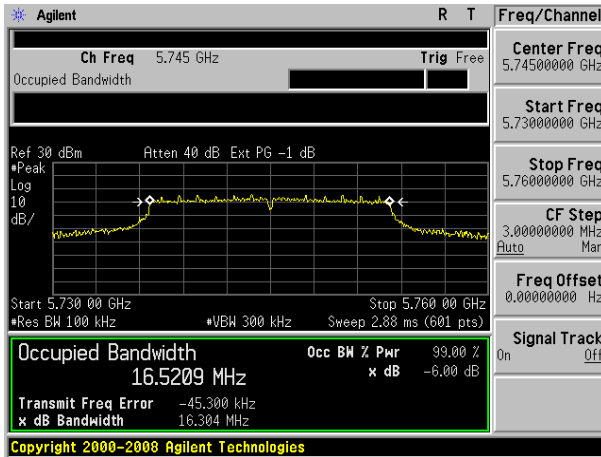

(802.11n20) -6dB Bandwidth plot on channel 149

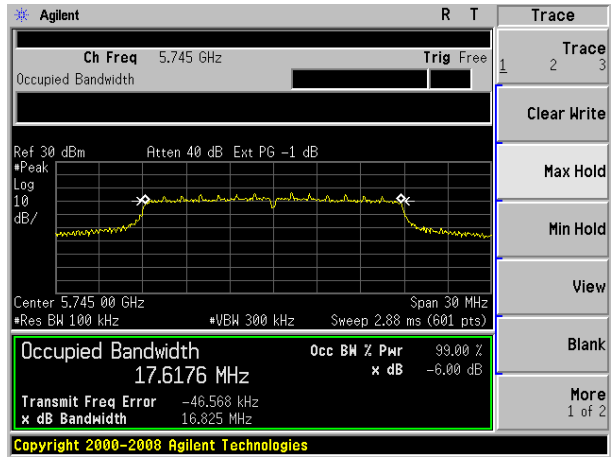

(802.11a) -6dB Bandwidth plot on channel 157

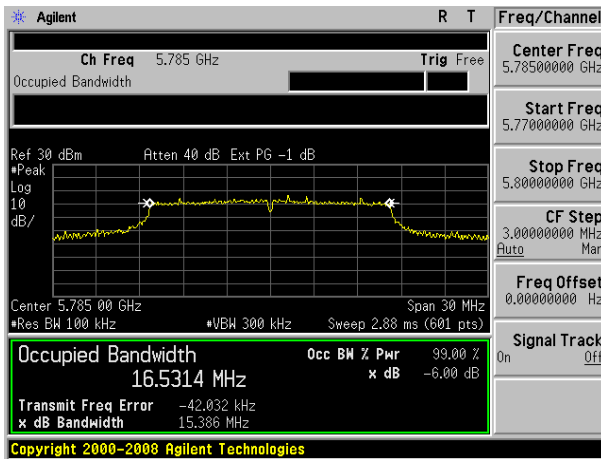

(802.11n20) -6dB Bandwidth plot on channel 157

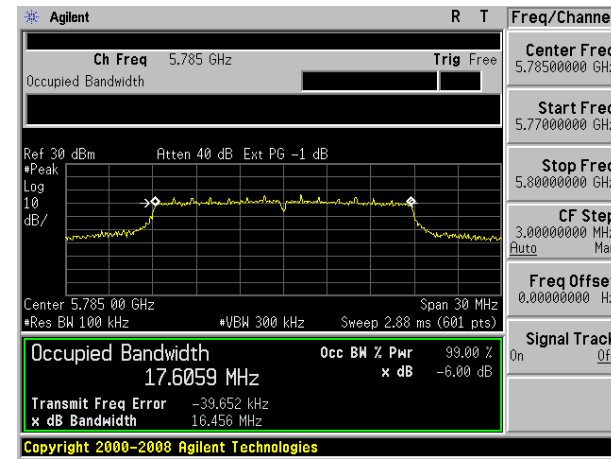

(802.11a) -6dB Bandwidth plot on channel 165

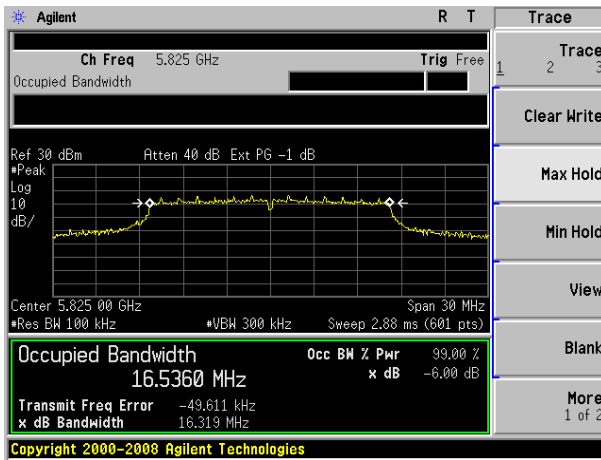

(802.11n20) -6dB Bandwidth plot on channel 165

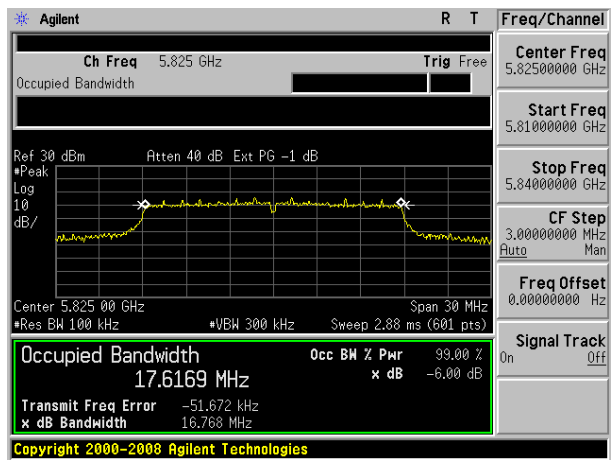

(802.11n40) -6dB Bandwidth plot on channel 151

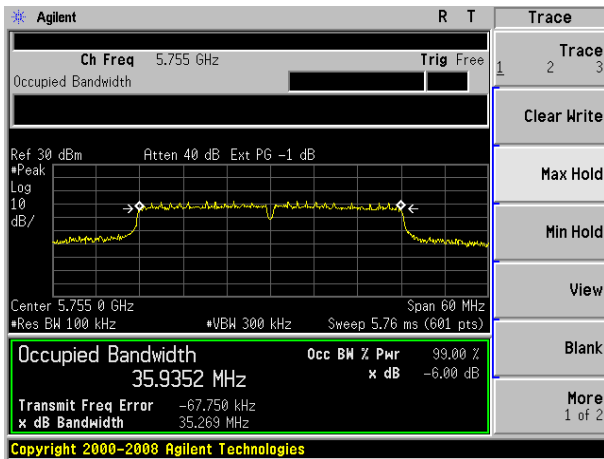

(802.11n40) -6dB Bandwidth plot on channel 159

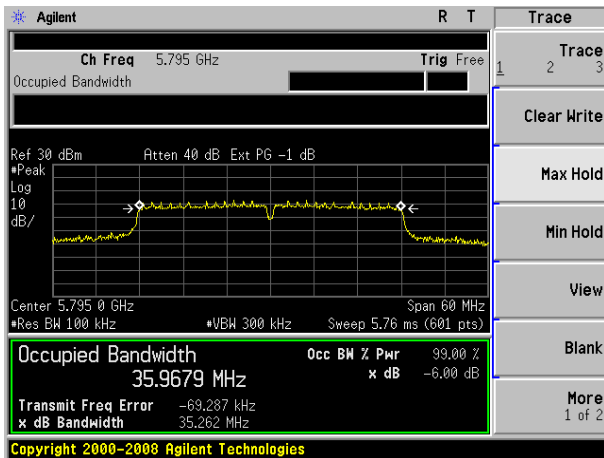

7. MAXIMUM CONDUCTED OUTPUT POWER

7.1 PPLIED PROCEDURES / LIMIT

According to FCC §15.407

The maximum conducted output power should not exceed:

Frequency Band(MHz)	Limit
5150~5250	250mW
5725~5850	1W

The maximum e.i.r.p should not exceed:

Frequency Band(MHz)	Limit
5150~5250	200mW or 10dBm +10logB whichever is less
5725~5850	N/A

Note: Where “B” is the 99% emission bandwidth in MHz

7.2 TEST PROCEDURE

· Maximum conducted output power may be measured using a spectrum analyzer/EMI receiver or an RF power meter.

1. Device Configuration

If possible, configure or modify the operation of the EUT so that it transmits continuously at its maximum power control level (see section II.B.).

a) The intent is to test at 100 percent duty cycle; however a small reduction in duty cycle (to no lower than 98 percent) is permitted if required by the EUT for amplitude control purposes. Manufacturers are expected to provide software to the test lab to permit such continuous operation.

b) If continuous transmission (or at least 98 percent duty cycle) cannot be achieved due to hardware limitations (e.g., overheating), the EUT shall be operated at its maximum power control level with the transmit duration as long as possible and the duty cycle as high as possible.

2. Measurement using a Spectrum Analyzer or EMI Receiver (SA)

Measurement of maximum conducted output power using a spectrum analyzer requires integrating the spectrum across a frequency span that encompasses, at a minimum, either the EBW or the 99-percent occupied bandwidth of the signal.¹ However, the EBW must be used to determine bandwidth dependent limits on maximum conducted output power in accordance with § 15.407(a).

a) The test method shall be selected as follows: (i) Method SA-1 or SA-1 Alternative (averaging with the EUT transmitting at full power throughout each sweep) shall be applied if either of the following conditions can be satisfied:

- The EUT transmits continuously (or with a duty cycle ≥ 98 percent).
- Sweep triggering or gating can be implemented in a way that the device transmits at the maximum power control level throughout the duration of each of the instrument sweeps to be averaged. This condition can generally be achieved by triggering the instrument's sweep if the duration of the sweep (with the analyzer configured as in Method SA-1, below) is equal to or shorter than the duration T of each transmission from the EUT and if those transmissions exhibit full power throughout their durations.

(ii) Method SA-2 or SA-2 Alternative (averaging across on and off times of the EUT transmissions, followed by duty cycle correction) shall be applied if the conditions of (i) cannot be achieved and the transmissions exhibit a constant duty cycle during the measurement duration. Duty cycle will be considered to be constant if variations are less than ± 2 percent.

(iii) Method SA-3 (RMS detection with max hold) or SA-3 Alternative (reduced VBW with max hold) shall be applied if the conditions of (i) and (ii) cannot be achieved.

b) Method SA-1 (trace averaging with the EUT transmitting at full power throughout each sweep): (i) Set span to encompass the entire emission bandwidth (EBW) (or, alternatively, the entire 99% occupied bandwidth) of the signal.

(ii) Set RBW = 1 MHz.

(iii) Set VBW ≥ 3 MHz.

(iv) Number of points in sweep ≥ 2 Span / RBW. (This ensures that bin-to-bin spacing is \leq RBW/2, so that narrowband signals are not lost between frequency bins.)

(v) Sweep time = auto.

(vi) Detector = RMS (i.e., power averaging), if available. Otherwise, use sample detector mode.

(vii) If transmit duty cycle < 98 percent, use a video trigger with the trigger level set to enable triggering only on full power pulses. Transmitter must operate at maximum power control level for the entire duration of every sweep. If the EUT transmits continuously (i.e., with no off intervals) or at duty cycle ≥ 98 percent, and if each transmission is entirely at the maximum power control level, then the trigger shall be set to "free run".

(viii) Trace average at least 100 traces in power averaging (i.e., RMS) mode.

(ix) Compute power by integrating the spectrum across the EBW (or, alternatively, the entire 99% occupied bandwidth) of the signal using the instrument's band power measurement function with band limits set equal to the EBW (or occupied bandwidth) band edges. If the instrument does not have a band power function, sum the spectrum

7.3 DEVIATION FROM STANDARD

No deviation.

7.4 TEST SETUP

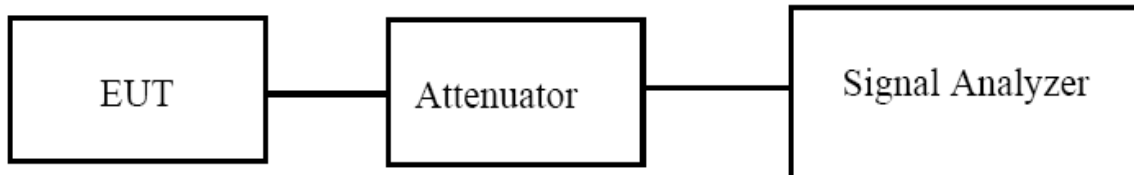

7.5 EUT OPERATION CONDITIONS

The EUT tested system was configured as the statements of 2.4 Unless otherwise a special operating condition is specified in the follows during the testing.

7.6 TEST RESULTS

EUT :	Nebula Mars	Model Name :	D2311
Temperature :	25 °C	Relative Humidity :	60%
Pressure :	1012 hPa	Test Voltage :	DC 11.4V
Test Mode :	TX (5G) Mode Frequency (5150-5250MHz)		

Note: EUT has two antennas, and different modes support different transmit mode what describe as Following form:

Mode	Tx/Rx
11a	1Tx, 1Rx
11n20,11n40	2Tx, 2Rx

Test Channel	Frequency	Maximum output power. Antenna port(dBm)	Maximum output power. Antenna port(dBm)	Total output power. Antenna port (dBm)		LIMIT	Result
		(AV)	(AV)	AV			
	(MHz)	Antenna A	Antenna B	Antenna A	Antenna B	dBm	
TX 802.11a Mode							
CH36	5180	17.4	17.0	-	-	23.98	Pass
CH40	5200	17.6	17.0	-	-	23.98	Pass
CH48	5240	17.4	17.0	-	-	23.98	Pass
TX 802.11 n20M Mode							
CH36	5180	16.7	16.5	19.61		21.42	Pass
CH40	5200	16.9	16.1	19.53		21.42	Pass
CH48	5240	16.7	16.3	19.51		21.42	Pass
TX 802.11 n40M Mode							
CH38	5190	17.1	16.0	19.60		21.42	Pass
CH46	5230	17.0	16.5	19.77		21.42	Pass

Note: For 802.11n 20M/40M Directional gain=GANT +10log(N)dBi =1.26dBi

1.26dBi<6.0 dBi so power limit= 21.42

EUT :	Nebula Mars	Model Name :	D2311
Temperature :	25 °C	Relative Humidity :	60%
Pressure :	1012 hPa	Test Voltage :	DC 11.4V
Test Mode :	TX (5G) Mode Frequency (5725-5825MHz)		

Note: EUT has two antennas, and different modes support different transmit mode what describe as Following form:

Mode	Tx/Rx
11a	1Tx, 1Rx
11n20,11n40	2Tx, 2Rx

Test Channel	Frequency	Maximum output power. Antenna port(dBm)	Maximum output power. Antenna port(dBm)	Total output power. Antenna port (dBm)		LIMIT	Result
		(AV)	(AV)	AV			
	(MHz)	Antenna A	Antenna B	Antenna A	Antenna B	dBm	
TX 802.11a Mode							
CH36	5745	17.8	16.5	-	-	30	Pass
CH40	5785	17.5	16.7	-	-	30	Pass
CH48	5825	17.4	16.4	-	-	30	Pass
TX 802.11 n20M Mode							
CH36	5745	17.1	16.2	19.68		27.44	Pass
CH40	5785	17.0	16.0	19.54		27.44	Pass
CH48	5825	17.1	15.9	19.55		27.44	Pass
TX 802.11 n40M Mode							
CH38	5755	17.4	16.0	19.77		27.44	Pass
CH46	5795	17.2	16.2	19.74		27.44	Pass

Note: For 802.11n 20M/40M Directional gain=GANT +10log(N)dBi =1.26dBi

1.26dBi<6.0 dBi so power limit= 27.44

8. OUT OF BAND EMISSIONS

8.1 APPLICABLE STANDARD

According to FCC §15.407(b)

Undesirable emission limits. Except as shown in paragraph (b)(7) of this section, the maximum emissions outside of the frequency bands of operation shall be attenuated in accordance with the following limits:

(1) For transmitters operating in the 5.15-5.25 GHz band: All emissions outside of the 5.15-5.35 GHz band shall not exceed an e.i.r.p. of -27 dBm/MHz.

(2) For transmitters operating in the 5.725-5.85 GHz band: All emissions shall be limited to a level of -27 dBm/MHz at 75 MHz or more above or below the band edge increasing linearly to 10 dBm/MHz at 25 MHz above or below the band edge, and from 25 MHz above or below the band edge increasing linearly to a level of 15.6 dBm/MHz at 5 MHz above or below the band edge, and from 5 MHz above or below the band edge increasing linearly to a level of 27 dBm/MHz at the band edge.

8.2 TEST PROCEDURE

1. Check the calibration of the measuring instrument using either an internal calibrator or a known signal from an external generator.
2. Position the EUT without connection to measurement instrument. Turn on the EUT and connect its antenna terminal to measurement instrument via a low loss cable. Then set it to any one measured frequency within its operating range, and make sure the instrument is operated in its linear range.
3. Set RBW of spectrum analyzer to 1 MHz with a convenient frequency span.
4. Measure the highest amplitude appearing on spectral display and set it as a reference level. Plot the graph with marking the highest point and edge frequency.
5. Repeat above procedures until all measured frequencies were complete.

8.3 DEVIATION FROM STANDARD

No deviation.

8.4 TEST SETUP

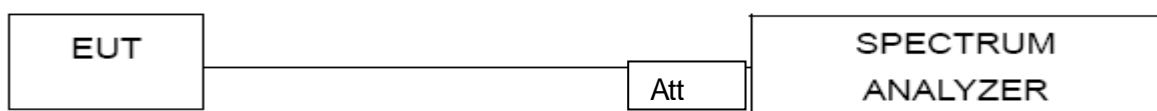

8.5 EUT OPERATION CONDITIONS

The EUT tested system was configured as the statements of 2.4 Unless otherwise a special operating condition is specified in the follows during the testing.

8.6 TEST RESULTS

EUT :	Nebula Mars	Model Name :	D2311
Temperature :	25 °C	Relative Humidity :	56%
Pressure :	1012 hPa	Test Voltage :	DC 11.4V

Note: A(B) Represent the value of antenna A and B, The worst data is Antenna A ,only shown Antenna A Plot.

5.2G

5.15~5.25 GHz

(802.11a) Band Edge, Left Side

(802.11n20) Band Edge, Left Side

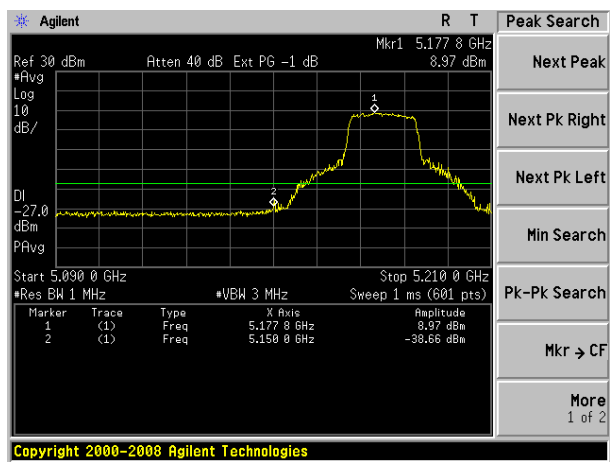
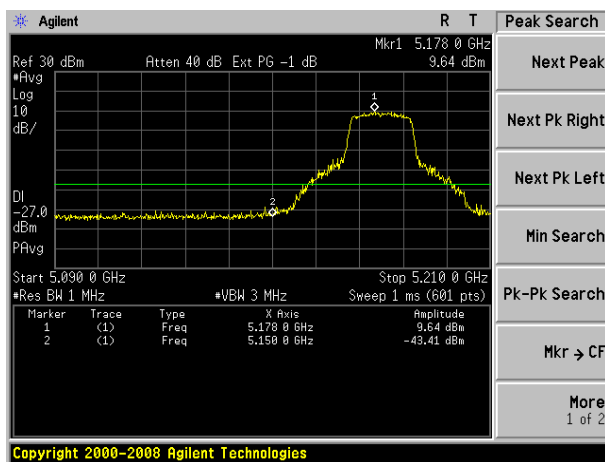

(802.11a) Band Edge, Right Side

(802.11n20) Band Edge, Right Side

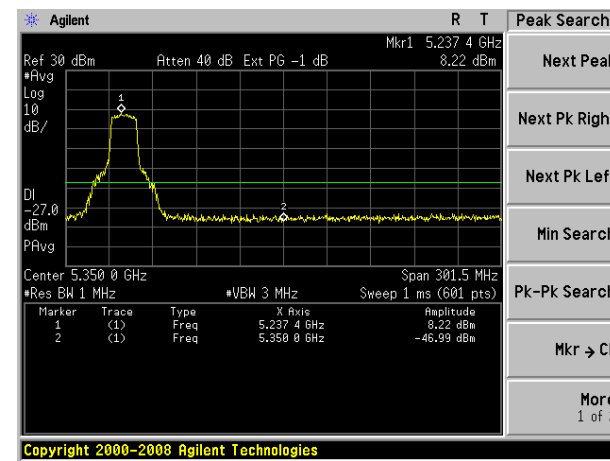
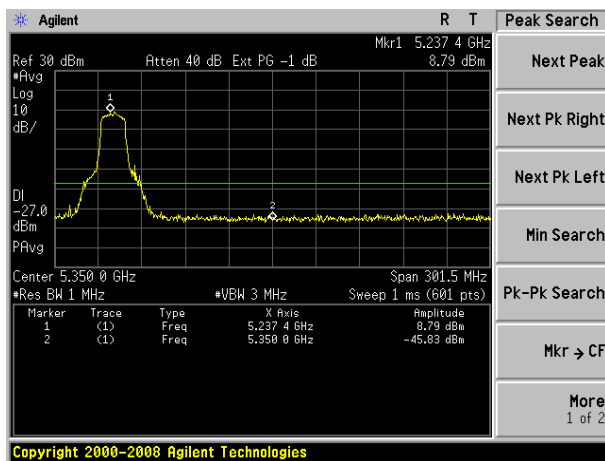

5.15~5.25 GHz

(802.11n40) Band Edge, Left Side

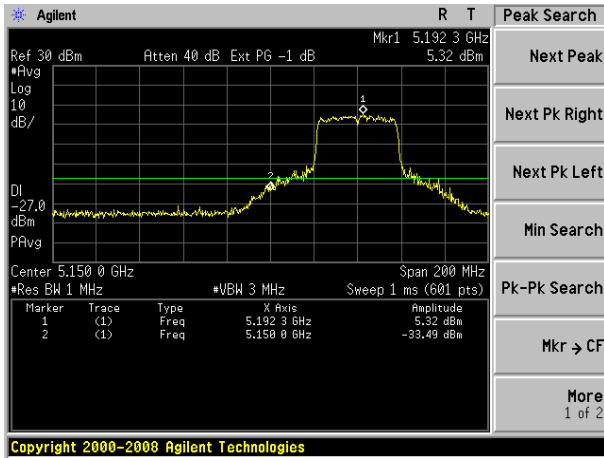

(802.11n40) Band Edge, Right Side

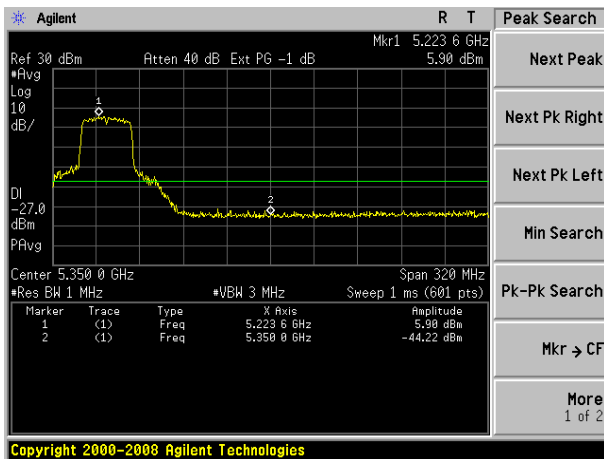

5.8G

5.725-5.85 GHz

(802.11a) Band Edge, Left Side

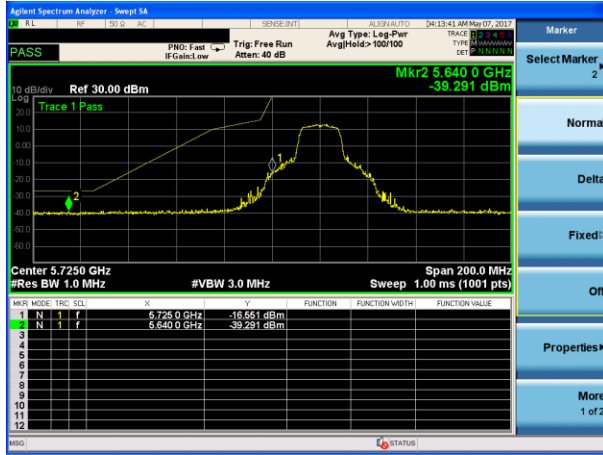

(802.11n20) Band Edge, Left Side

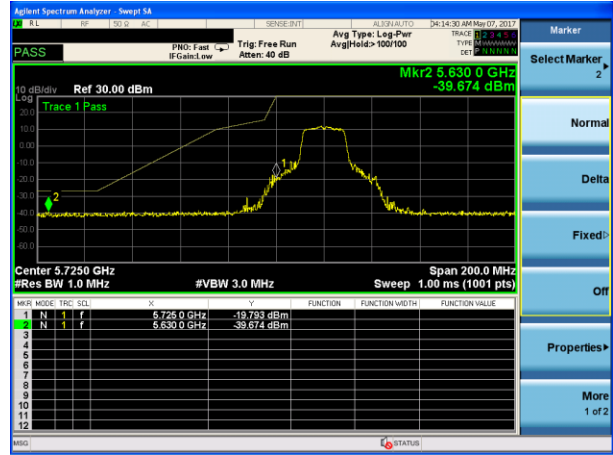

(802.11a) Band Edge, Right Side

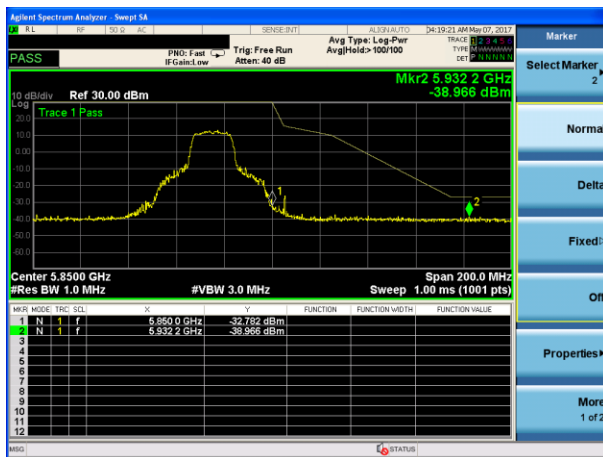

(802.11n20) Band Edge, Right Side

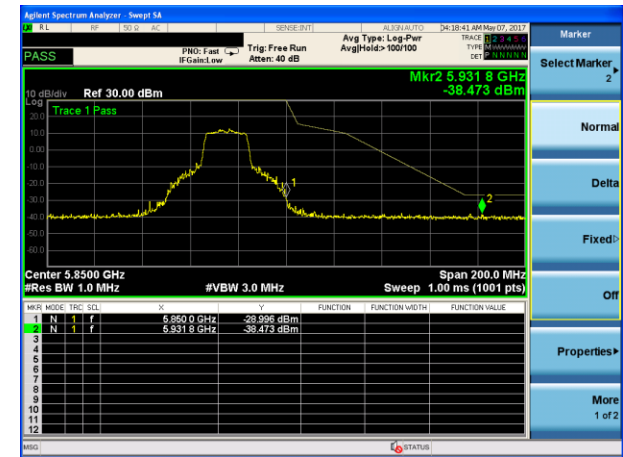

5.725-5.85 GHz

(802.11n40) Band Edge, Left Side

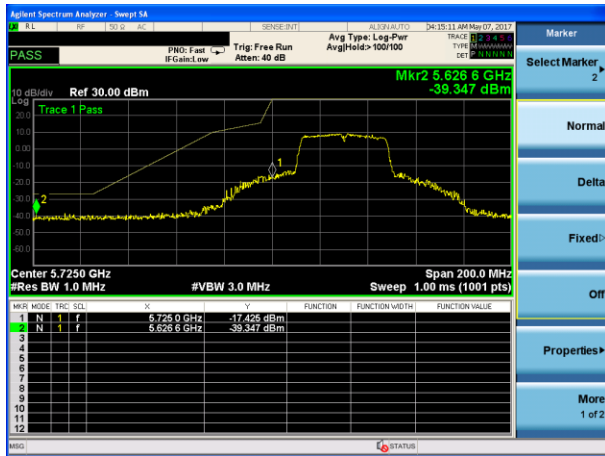

(802.11n40) Band Edge, Right Side

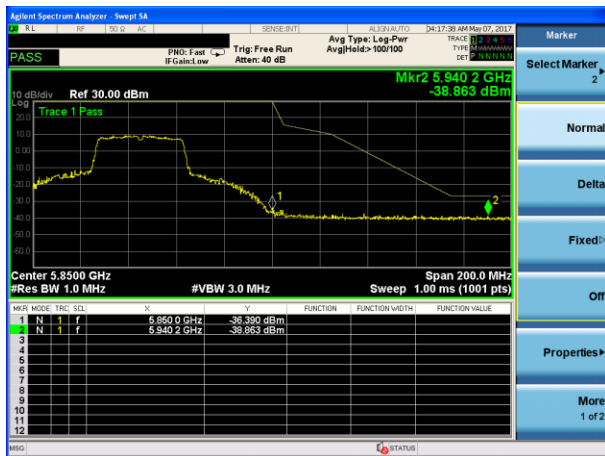

9.SPURIOUS RF CONDUCTED EMISSIONS

9.1CONFORMANCE LIMIT

1. Below -20dB of the highest emission level in operating band.
2. Fall in the restricted bands listed in section 15.205. The maximum permitted average field strength is listed in section 15.209.

9.2MEASURING INSTRUMENTS

The Measuring equipment is listed in the section 6.3 of this test report.

9.3TEST SETUP

Please refer to Section 6.1 of this test report.

9.4TEST PROCEDURE

The Spurious RF conducted emissions compliance of RF radiated emission should be measured by following the guidance in ANSI C63. 10-2013 with respect to maximizing the emission by rotating the EUT, measuring the emission while the EUT is situated in three orthogonal planes (if appropriate), adjusting the measurement antenna height and polarization etc. Set RBW=100kHz and VBW= 300KHz to measure the peak field strength , and mwasure frequeny range from 9KHz to 26.5GHz.

9.5TEST RESULTS

Remark: The measurement frequency range is from 9KHz to the 10th harmonic of the fundamental frequency. The lowest, middle and highest channels are tested to verify the spurious emissions and bandedge measurement data.

Note: A(B) Represent the value of antenna A and B, The worst data is Antenna A ,only shown Antenna A Plot.

5.2G Test Plot

802.11a on channel 36

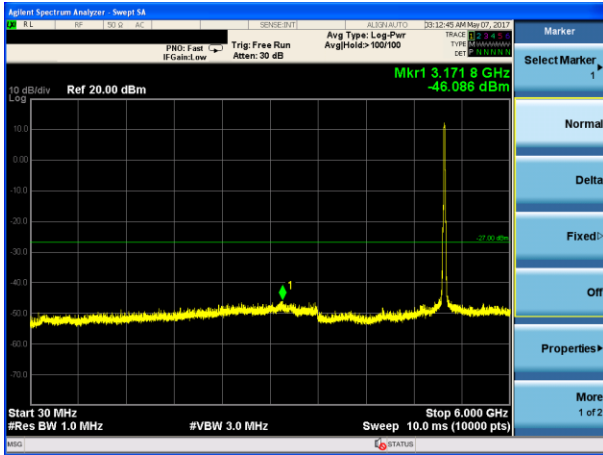

802.11a on channel 40

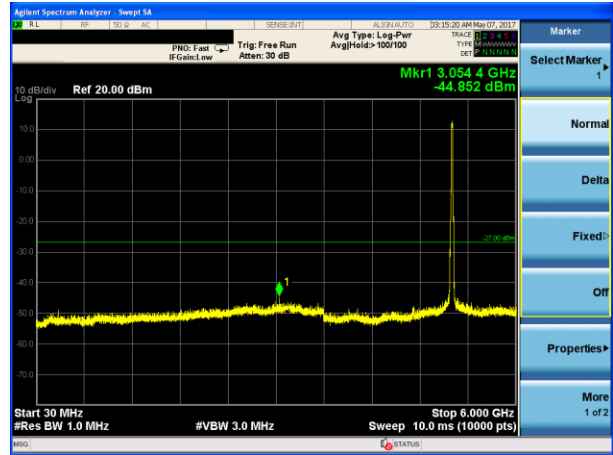

802.11a on channel 36

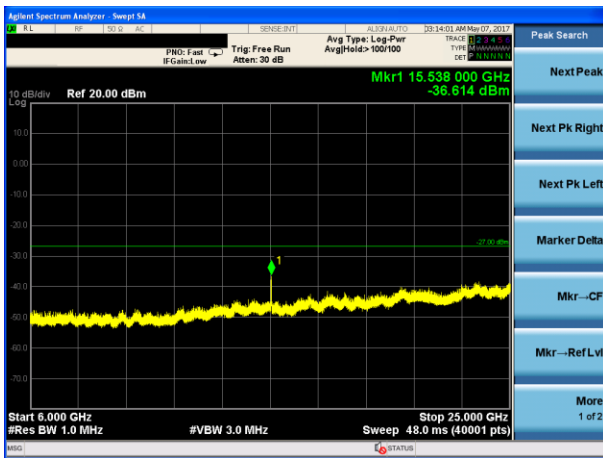

802.11a on channel 40

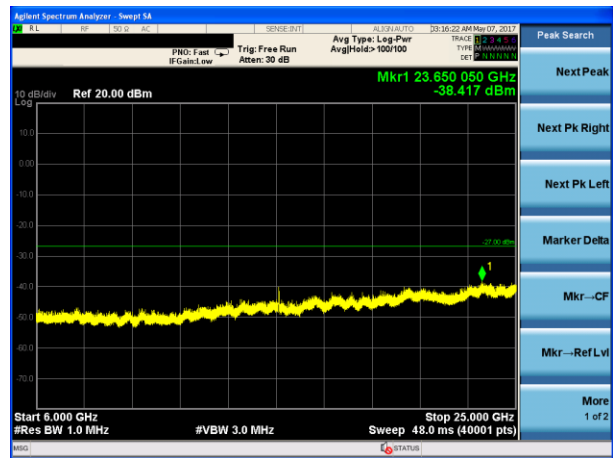

Test Plot

802.11a on channel 48

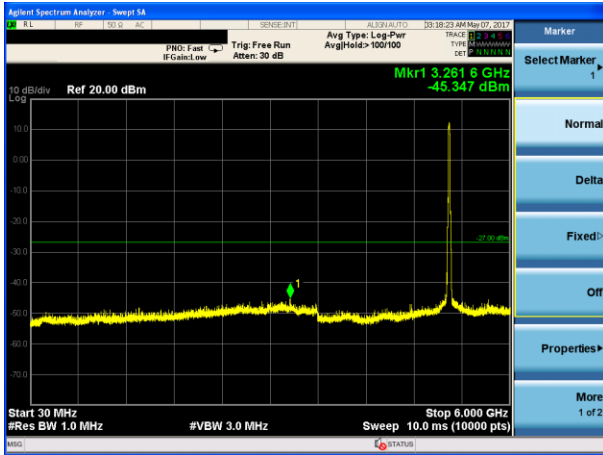

802.11n20 on channel 36

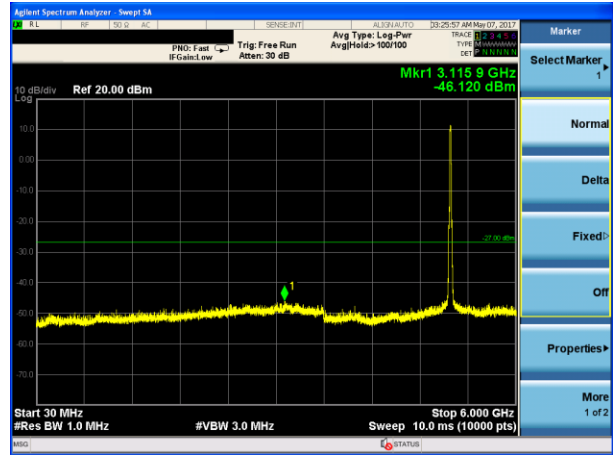

802.11a on channel 48

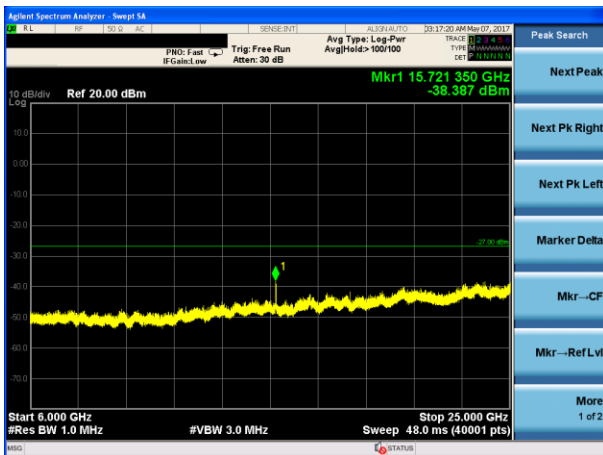

802.11n20 on channel 36

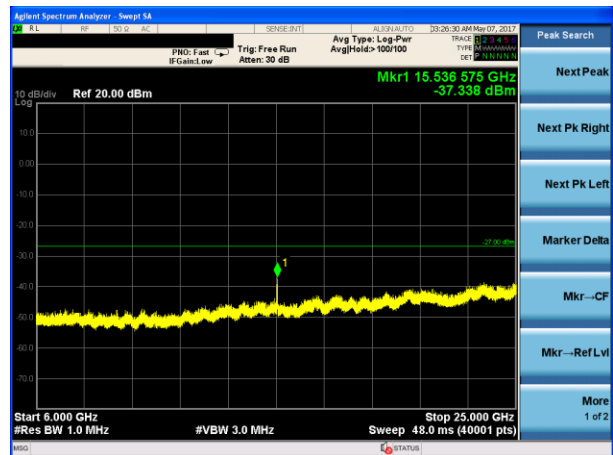

Test Plot

802.11n20 on channel 40

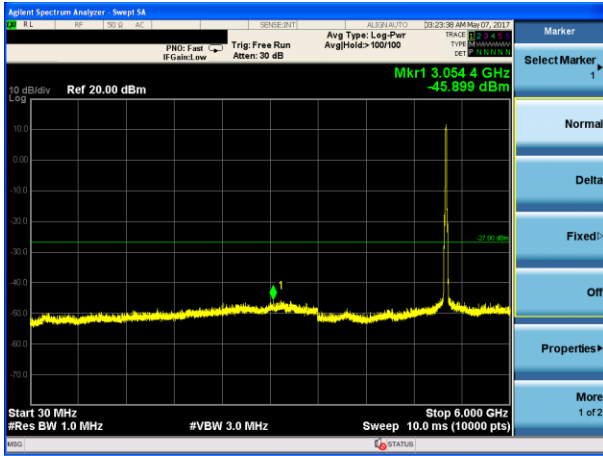

802.11n20 on channel 48

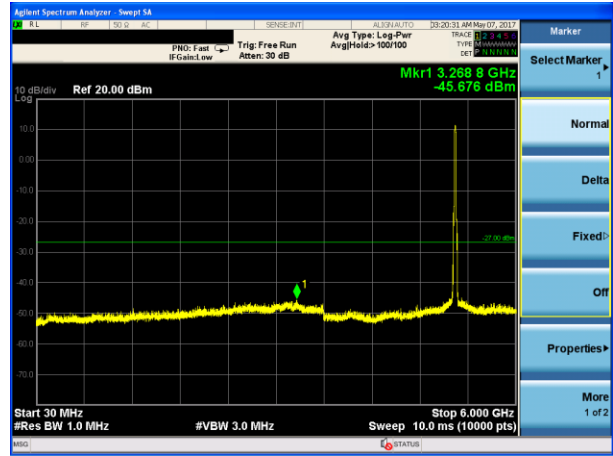

802.11n20 on channel 40

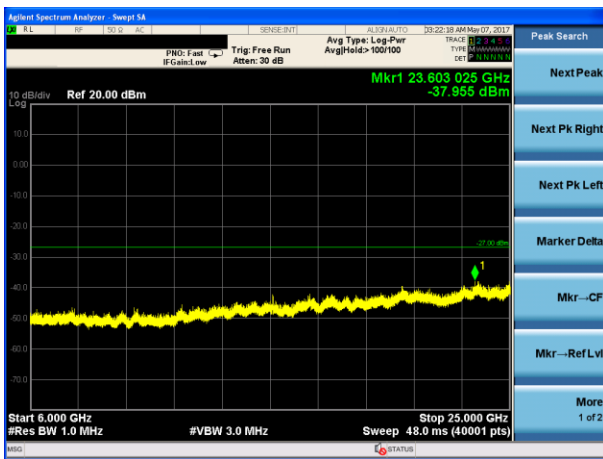

802.11n20 on channel 48

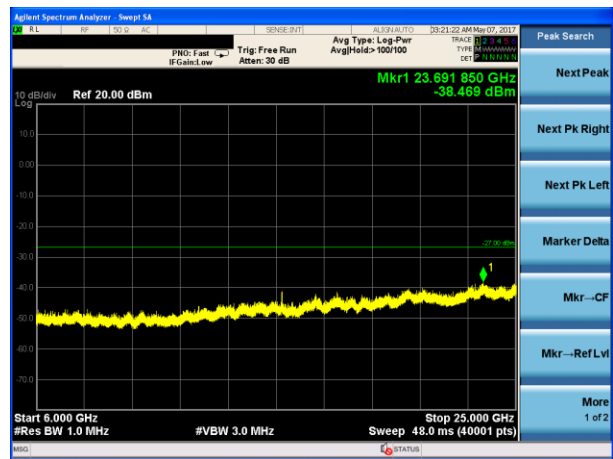

Test Plot

802.11n40 on channel 38

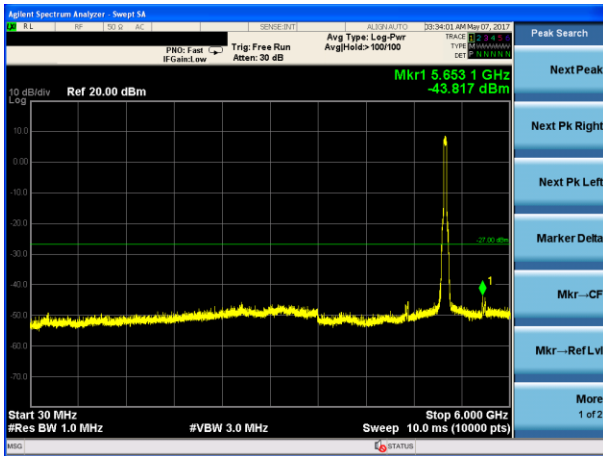

802.11n40 on channel 46

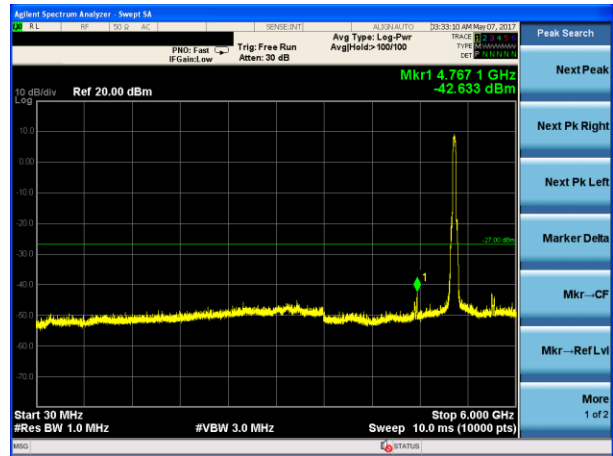

802.11n40 on channel 38

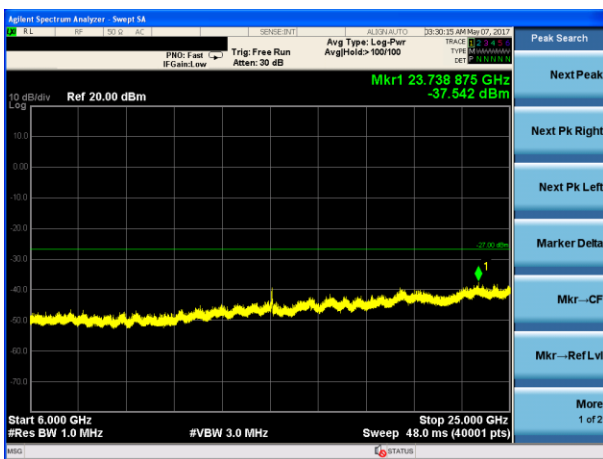

802.11n40 on channel 46

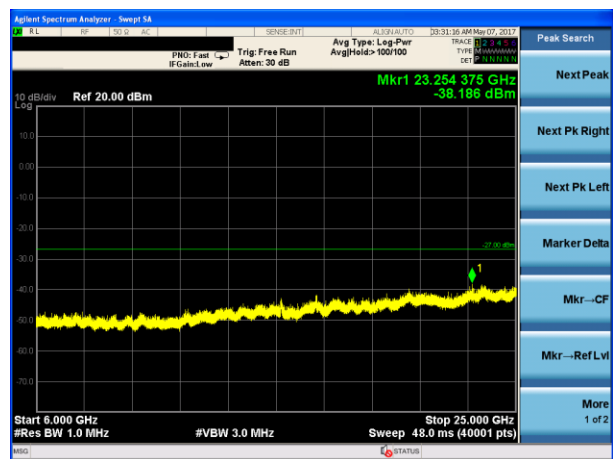

Note: A(B) Represent the value of antenna A and B, The worst data is A Antenna a , only shown Antenna A Plot.

5.8G Test Plot

802.11a on channel 149

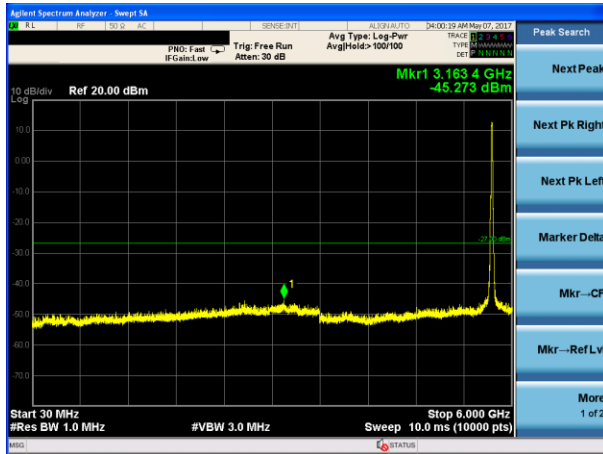

802.11a on channel 157

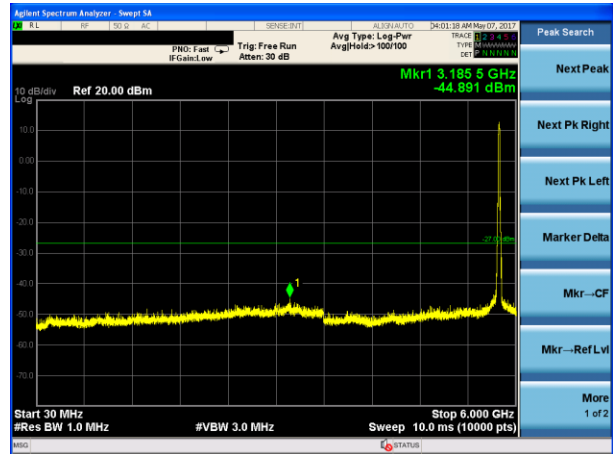

802.11a on channel 149

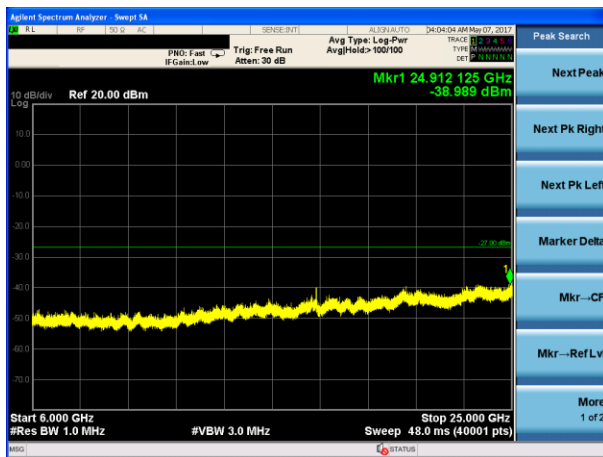

802.11a on channel 157

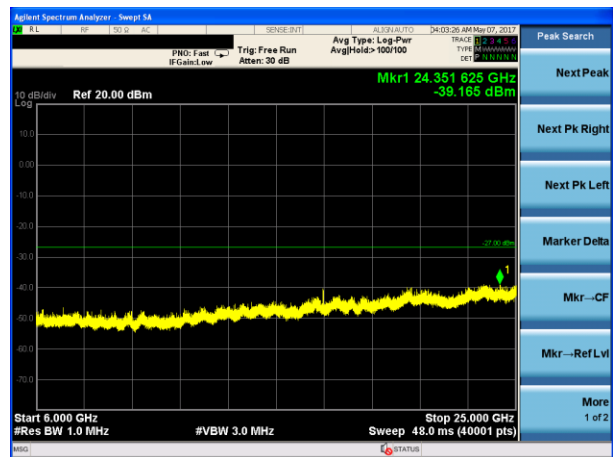

Test Plot

802.11a on channel 165

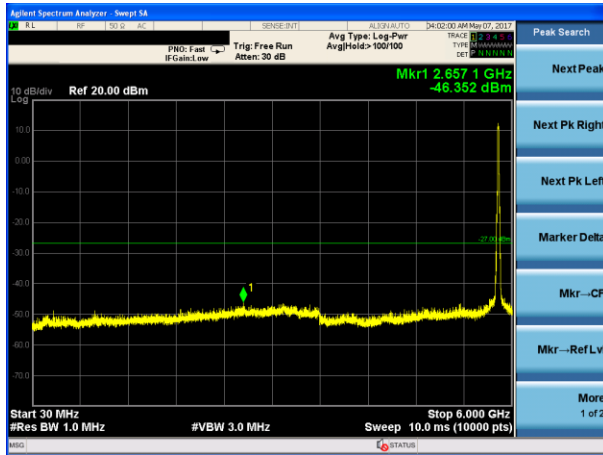

802.11n20 on channel 149

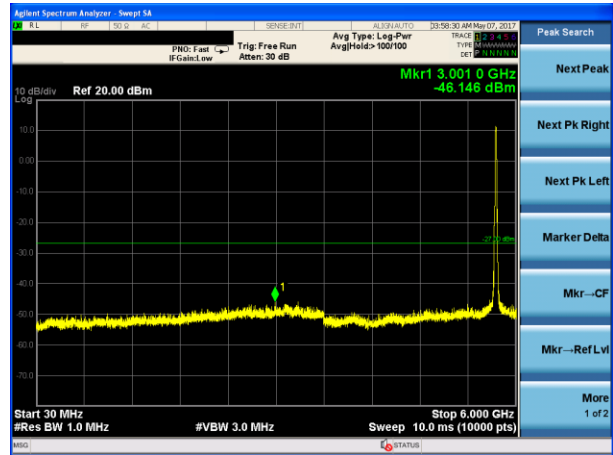

802.11a on channel 165

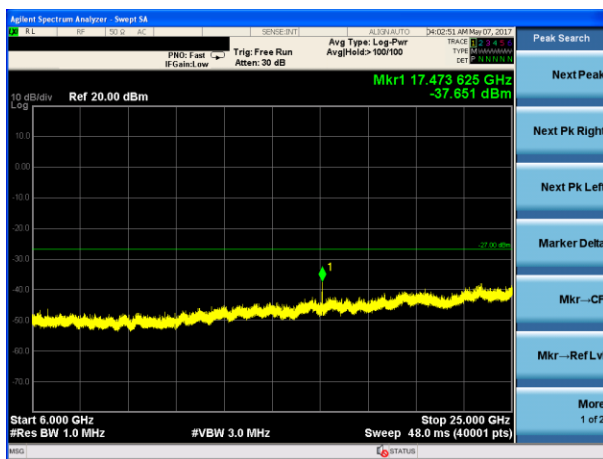

802.11n20 on channel 149

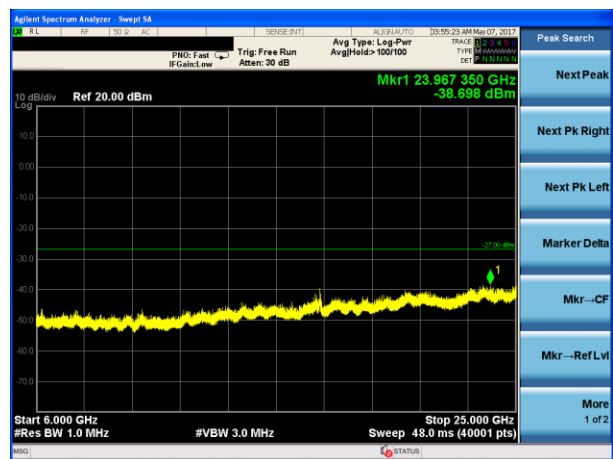

Test Plot

802.11n20 on channel 157

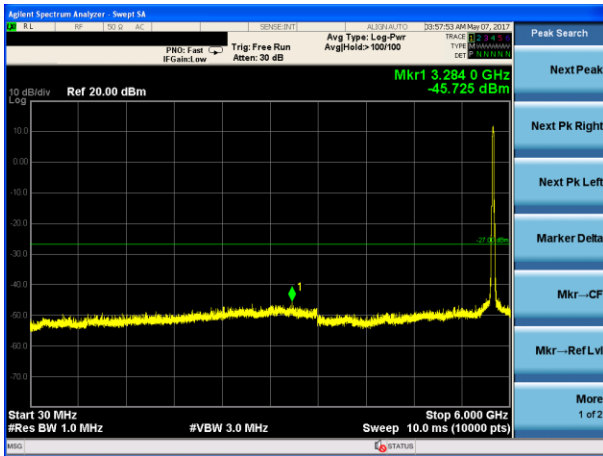

802.11n20 on channel 165

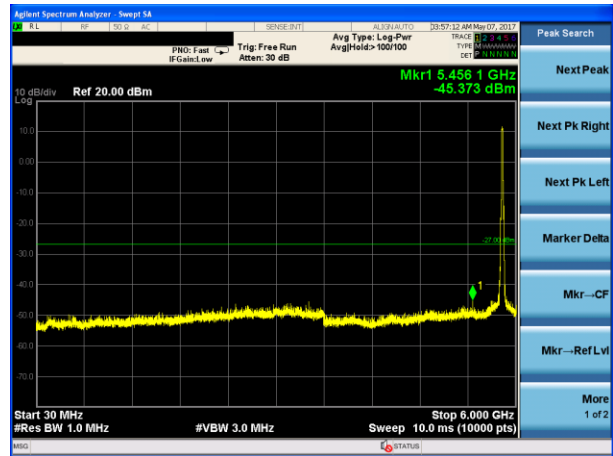

802.11n20 on channel 157

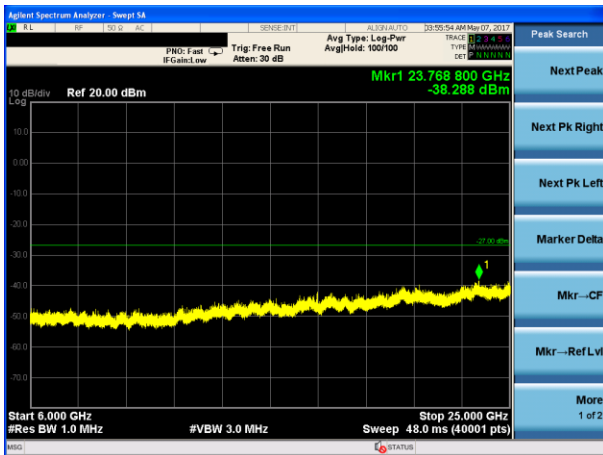

802.11n20 on channel 165

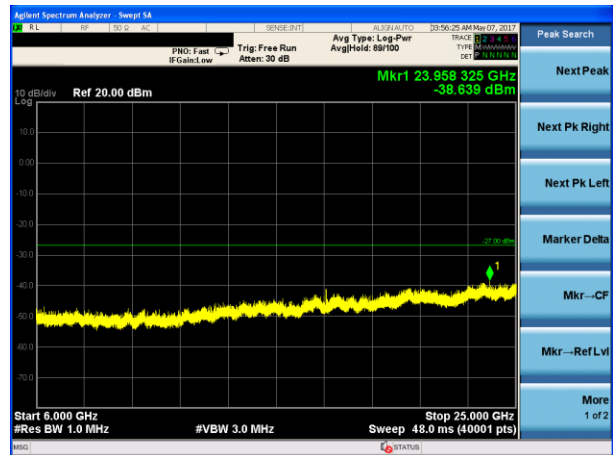

Test Plot

802.11n40 on channel 151

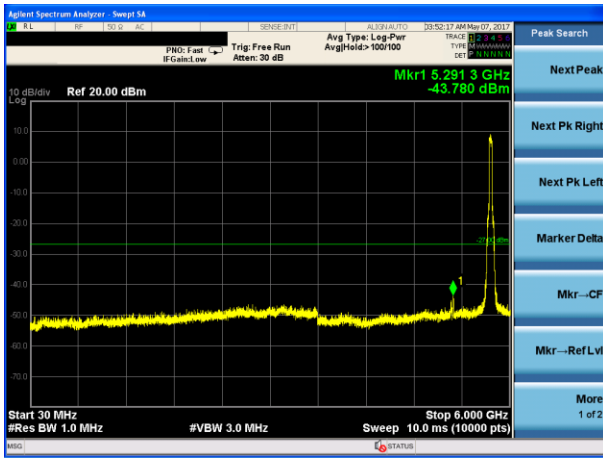

802.11n40 on channel 159

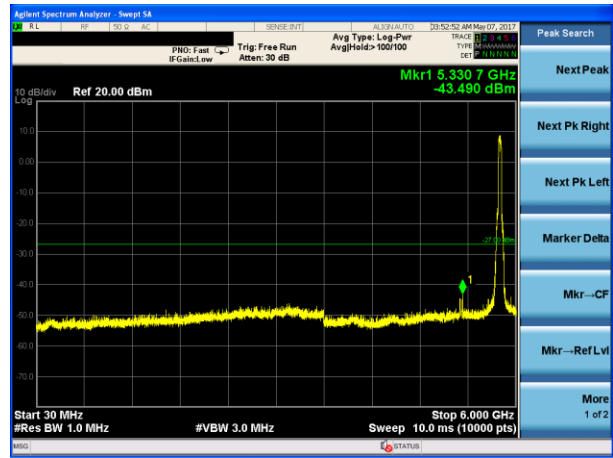

802.11n40 on channel 151

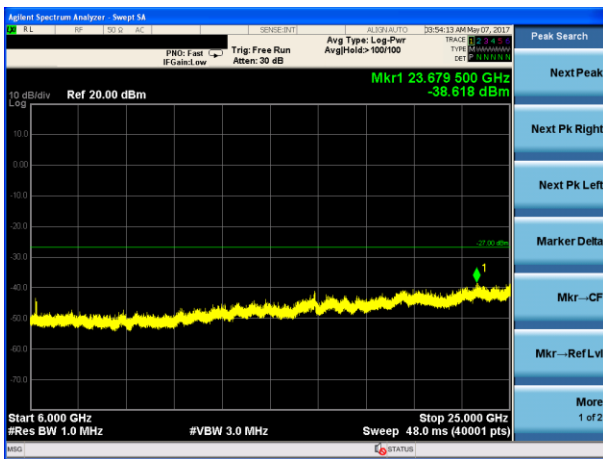

802.11n40 on channel 159

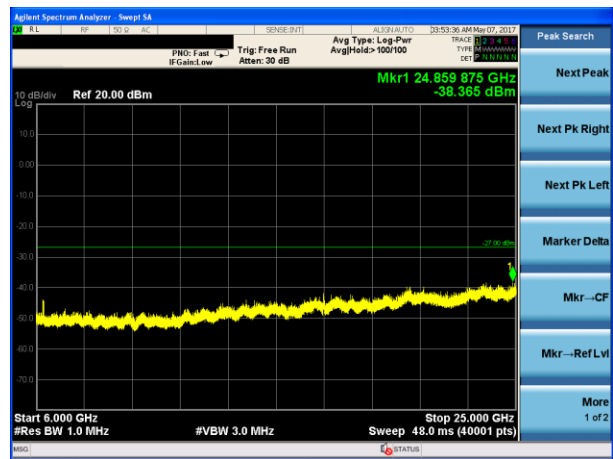

10. Frequency Stability Measurement

10.1 LIMIT

Manufacturers of U-NII devices are responsible for ensuring frequency stability such that an emission is maintained within the band of operation under all conditions of normal operation as specified in the user's manual.

The transmitter center frequency tolerance shall be ± 20 ppm maximum for the 5 GHz band (IEEE802.11n specification).

10.2 TEST PROCEDURES

1. The transmitter output (antenna port) was connected to the spectrum analyzer.
2. EUT have transmitted absence of modulation signal and fixed channelize.
3. Set the spectrum analyzer span to view the entire absence of modulation emissions bandwidth.
4. Set RBW = 10 kHz, VBW = 10 kHz with peak detector and maxhold settings.
5. f_c is declaring of channel frequency. Then the frequency error formula is $(f_c - f)/f_c \times 10^6$ ppm and the limit is less than ± 20 ppm (IEEE 802.11n specification).
6. The test extreme voltage is to change the primary supply voltage from 85 to 115 percent of the nominal value
7. Extreme temperature is $-20^\circ\text{C} \sim 70^\circ\text{C}$.

10.3 TEST SETUP LAYOUT

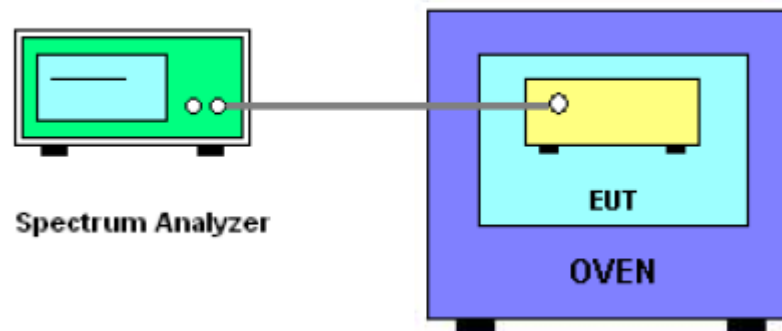

10.4 EUT OPERATION DURING TEST

The EUT was programmed to be in continuously un-modulation transmitting mode.

10.5 TEST RESULTS

EUT :	Nebula Mars	Model Name :	D2311
Temperature :	25 °C	Relative Humidity :	60%
Pressure :	1015 hPa	Test Voltage :	DC 3.7V
Test Mode :	TX Frequency(5150-5250MHz)		

Voltage vs. Frequency Stability

TEST CONDITIONS				Reference Frequency: 5180MHz			
				f	fc	Max. Deviation (MHz)	Max. Deviation (ppm)
T nom (°C)	20	V nom (V)	11.40	5180.00889	5180	0.00889	-1.7165
		V max (V)	13.11	5180.00983	5180	0.00983	-1.8976
		V min (V)	9.69	5180.00972	5180	0.00972	-1.8760
Limits				± 20 ppm			
Result				Complies			

Temperature vs. Frequency Stability

TEST CONDITIONS				Reference Frequency: 5180MHz			
				f	fc	Max. Deviation (MHz)	Max. Deviation (ppm)
V nom (V)	11.4	T (°C)	-20	5180.01105	5180	0.01105	-2.1334
		T (°C)	-10	5180.00455	5180	0.00455	-0.8775
		T (°C)	0	5180.00020	5180	0.00020	-0.0393
		T (°C)	10	5180.00131	5180	0.00131	-0.2525
		T (°C)	20	5180.00281	5180	0.00281	-0.5418
		T (°C)	30	5180.00166	5180	0.00166	-0.3211
		T (°C)	40	5180.00422	5180	0.00422	-0.8156
		T (°C)	50	5180.00153	5180	0.00153	-0.2945
		T (°C)	60	5180.00988	5180	0.00988	-1.9079
		T (°C)	70	5180.00393	5180	0.00393	-0.7582
Limits				± 20 ppm			
Result				Complies			

TEST CONDITIONS				Reference Frequency: 5200MHz			
				f	fc	Max. Deviation (MHz)	Max. Deviation (ppm)
T nom (°C)	20	V nom (V)	11.40	5200.00653	5200	0.00653	-1.2559
		V max (V)	13.11	5200.00024	5200	0.00024	-0.0456
		V min (V)	9.69	5200.00175	5200	0.00175	-0.3365
Limits				± 20 ppm			
Result				Complies			

Voltage vs. Frequency Stability

Temperature vs. Frequency Stability

TEST CONDITIONS				Reference Frequency: 5200MHz			
				f	fc	Max. Deviation (MHz)	Max. Deviation (ppm)
V nom (V)	11.4	T (°C)	-20	5200.00222	5200	0.00222	-0.4271
		T (°C)	-10	5200.00516	5200	0.00516	-0.9921
		T (°C)	0	5200.01141	5200	0.01141	-2.1945
		T (°C)	10	5200.01020	5200	0.01020	-1.9611
		T (°C)	20	5200.00860	5200	0.00860	-1.6542
		T (°C)	30	5200.00315	5200	0.00315	-0.6052
		T (°C)	40	5200.00367	5200	0.00367	-0.7052
		T (°C)	50	5200.00293	5200	0.00293	-0.5642
		T (°C)	60	5200.00047	5200	0.00047	-0.0912
		T (°C)	70	5200.00452	5200	0.00452	-0.8687
Limits				± 20 ppm			

Voltage vs. Frequency Stability

TEST CONDITIONS				Reference Frequency: 5240MHz			
				f	fc	Max. Deviation (MHz)	Max. Deviation (ppm)
T nom (°C)	20	V nom (V)	11.40	5240.00165	#####	5240	0.00787
		V max (V)	13.11	5240.00118	#####	5240	0.00117
		V min (V)	9.69	5240.00681	#####	5240	0.00606
Limits				± 20 ppm			
Result				Complies			

Temperature vs. Frequency Stability

TEST CONDITIONS				Reference Frequency: 5240MHz			
				f	fc	Max. Deviation (MHz)	Max. Deviation (ppm)
V nom (V)	11.4	T (°C)	-20	5240.01299	5240	0.01299	-2.4785
		T (°C)	-10	5240.00359	5240	0.00359	-0.6852
		T (°C)	0	5240.00110	5240	0.00110	-0.2092
		T (°C)	10	5240.00406	5240	0.00406	-0.7747
		T (°C)	20	5240.00124	5240	0.00124	-0.2370
		T (°C)	30	5240.01243	5240	0.01243	-2.3720
		T (°C)	40	5240.00351	5240	0.00351	-0.6701
		T (°C)	50	5240.00447	5240	0.00447	-0.8538
		T (°C)	60	5240.01243	5240	0.01243	-2.3721
		T (°C)	70	5240.00574	5240	0.00574	-1.0950
Limits				± 20 ppm			

EUT :	Nebula Mars	Model Name :	D2311
Temperature :	25 °C	Relative Humidity :	60%
Pressure :	1015 hPa	Test Voltage :	DC 3.7V
Test Mode :	TX Frequency(5745-5850MHz)		

TEST CONDITIONS				Reference Frequency: 5745MHz			
				f	fc	Max. Deviation (MHz)	Max. Deviation (ppm)
T nom (°C)	20	V nom (V)	11.40	5745.00920	5745	0.00920	-1.6021
		V max (V)	13.11	5745.00356	5745	0.00356	-0.6202
		V min (V)	9.69	5745.00582	5745	0.00582	-1.0136
Limits				± 20 ppm			
Result				Complies			

Voltage vs. Frequency Stability

Temperature vs. Frequency Stability

TEST CONDITIONS				Reference Frequency: 5745MHz			
				f	fc	Max. Deviation (MHz)	Max. Deviation (ppm)
V nom (V)	11.4	T (°C)	-20	5745.01203	5745	0.01203	-2.0948
		T (°C)	-10	5745.00399	5745	0.00399	-0.6937
		T (°C)	0	5745.00920	5745	0.00920	-1.6019
		T (°C)	10	5745.01144	5745	0.01144	-1.9911
		T (°C)	20	5745.01020	5745	0.01020	-1.7763
		T (°C)	30	5745.00472	5745	0.00472	-0.8218
		T (°C)	40	5745.00918	5745	0.00918	-1.5982
		T (°C)	50	5745.00822	5745	0.00822	-1.4312
		T (°C)	60	5745.01279	5745	0.01279	-2.2262
		T (°C)	70	5745.00114	5745	0.00114	-0.1979
Limits				± 20 ppm			
Result				Complies			

Voltage vs. Frequency Stability

TEST CONDITIONS				Reference Frequency: 5785MHz			
				f	fc	Max. Deviation (MHz)	Max. Deviation (ppm)
T nom (°C)	20	V nom (V)	11.40	5785.00926	5785	0.00926	-1.6009
		V max (V)	13.11	5785.01292	5785	0.01292	-2.2338
		V min (V)	9.69	5785.01259	5785	0.01259	-2.1764
Limits				± 20 ppm			
Result				Complies			

Temperature vs. Frequency Stability

TEST CONDITIONS				Reference Frequency: 5785MHz			
				f	fc	Max. Deviation (MHz)	Max. Deviation (ppm)
V nom (V)	11.4	T (°C)	-20	5785.00234	5785	0.00234	-0.4038
		T (°C)	-10	5785.00229	5785	0.00229	-0.3961
		T (°C)	0	5785.00647	5785	0.00647	-1.1181
		T (°C)	10	5785.00161	5785	0.00161	-0.2783
		T (°C)	20	5785.01290	5785	0.01290	-2.2302
		T (°C)	30	5785.00446	5785	0.00446	-0.7714
		T (°C)	40	5785.00720	5785	0.00720	-1.2441
		T (°C)	50	5785.00059	5785	0.00059	-0.1013
		T (°C)	60	5785.00409	5785	0.00409	-0.7076
		T (°C)	70	5785.00214	5785	0.00214	-0.3692
Limits				± 20 ppm			
Result				Complies			

Voltage vs. Frequency Stability

TEST CONDITIONS				Reference Frequency: 5825MHz			
				f	fc	Max. Deviation (MHz)	Max. Deviation (ppm)
T nom (°C)	20	V nom (V)	11.40	5825.01197	5825	0.01197	-2.0555
		V max (V)	13.11	5825.01171	5825	0.01171	-2.0108
		V min (V)	9.69	5825.01122	5825	0.01122	-1.9267
Limits				± 20 ppm			
Result				Complies			

Temperature vs. Frequency Stability

TEST CONDITIONS				Reference Frequency: 5825MHz			
				f	fc	Max. Deviation (MHz)	Max. Deviation (ppm)
V nom (V)	11.4	T (°C)	-20	5825.00107	5825	0.00107	-0.1836
		T (°C)	-10	5825.00727	5825	0.00727	-1.2474
		T (°C)	0	5825.00565	5825	0.00565	-0.9699
		T (°C)	10	5825.00797	5825	0.00797	-1.3679
		T (°C)	20	5825.01121	5825	0.01121	-1.9237
		T (°C)	30	5825.00855	5825	0.00855	-1.4672
		T (°C)	40	5825.00267	5825	0.00267	-0.4575
		T (°C)	50	5825.00990	5825	0.00990	-1.6997
		T (°C)	60	5825.00622	5825	0.00622	-1.0673
		T (°C)	70	5825.01223	5825	0.01223	-2.0999
Limits				± 20 ppm			
Result				Complies			

11. ANTENNA REQUIREMENT

11.1 STANDARD REQUIREMENT

15.203 requirement: For intentional device, according to 15.203: an intentional radiator shall be designed to ensure that no antenna other than that furnished by the responsible party shall be used with the device.

11.2 EUT ANTENNA

The EUT antenna is permanent attached FPCB antenna (antenna gain:1 dBi). It comply with the standard requirement.