

FCC TEST REPORT

For

Anker Technology Co., Limited.

Powerport Wireless 5 Pad

Model No.: A2518

Prepared For : Anker Technology Co., Limited.
Address : Room 1318-19, Hollywood Plaza, 610 Nathan Road, Mongkok, Kowloon,
Hongkong

Prepared By : Shenzhen Anbotek Compliance Laboratory Limited
Address : 1/F., Building 1, SEC Industrial Park, No.0409 Qianhai Road, Nanshan
District, Shenzhen, Guangdong, China
Tel: (86) 755-26066544 Fax: (86) 755-26014772

Report Number : R0217090003W1
Date of Test : Sept. 06~12, 2017
Date of Report : Sept. 13, 2017

Contents

1. General Information.....	4
1.1. Client Information.....	4
1.2. Description of Device (EUT).....	4
1.3. Auxiliary Equipment Used During Test.....	4
1.4. Description of Test Modes.....	5
1.5. List of channels.....	5
1.6. Description Of Test Setup.....	6
1.7. Test Equipment List.....	7
1.8. Measurement Uncertainty.....	8
1.9. Description of Test Facility.....	8
2. Summary of Test Results.....	9
3. Conducted Emission Test.....	10
3.1. Test Standard and Limit.....	10
3.2. Test Setup.....	10
3.3. Test Procedure.....	10
3.4. Test Data.....	10
4. Radiation Spurious Emission and Band Edge.....	13
4.1. Test Standard and Limit.....	15
4.2. Test Setup.....	15
4.3. Test Procedure.....	16
4.4. Test Data.....	17
APPENDIX I -- TEST SETUP PHOTOGRAPH.....	21
APPENDIX II -- EXTERNAL PHOTOGRAPH.....	23
APPENDIX III -- INTERNAL PHOTOGRAPH.....	27

TEST REPORT

Applicant : Anker Technology Co., Limited.
Manufacturer : SHENZHEN RUIJING INDUSTRIAL CO., LTD
Product Name : Powerport Wireless 5 Pad
Model No. : A2518
Trade Mark : **ANKER**
Rating(s) : Input: DC 5.0V 2A
Output: DC 5.0V 1A

Test Standard(s) : **FCC Part15 Subpart C 2016, Paragraph 15.209**

Test Method(s) : **ANSI C63.10: 2013**

The device described above is tested by Shenzhen Anbotek Compliance Laboratory Limited to determine the maximum emission levels emanating from the device and the severe levels of the device can endure and its performance criterion. The measurement results are contained in this test report and Shenzhen Anbotek Compliance Laboratory Limited is assumed full of responsibility for the accuracy and completeness of these measurements. Also, this report shows that the EUT (Equipment Under Test) is technically compliant with the FCC Part 15 Subpart C requirements.

This report applies to above tested sample only and shall not be reproduced in part without written approval of Shenzhen Anbotek Compliance Laboratory Limited.

Date of Test : Sept. 06~12, 2017

Prepared by :



Winkey Wang

(Tested Engineer / Winkey Wang)

Reviewer :

Tangcy. T.

(Project Manager / Tangcy T)

Approved & Authorized Signer :

Tom Chen

(Manager / Tom Chen)

1. General Information

1.1. Client Information

Applicant	:	Anker Technology Co., Limited.
Address	:	Room 1318-19, Hollywood Plaza, 610 Nathan Road, Mongkok, Kowloon, Hongkong
Manufacturer	:	SHENZHEN RUIJING INDUSTRIAL CO., LTD
Address	:	C1 Building, Hengli Industrial Area, Xiakeng 1st Road No.168, Longgang Street, Longgang District, Shenzhen, Guangdong, China

1.2. Description of Device (EUT)

Product Name	:	Powerport Wireless 5 Pad	
Model No.	:	A2518	
Trade Mark	:	ANKER	
Test Power Supply	:	AC 120V, 60Hz for adapter / AC 240V, 60Hz for adapter	
Product Description	:	Operation Frequency:	110-205KHz
	:	Number of Channel:	20 Channels
	:	Modulation Type:	MSK
	:	Antenna Type:	Inductive loop coil Antenna
	:	Antenna Gain(Peak):	0 dBi
Remark: 1) For a more detailed features description, please refer to the manufacturer's specifications or the User's Manual.			

1.3. Auxiliary Equipment Used During Test

Mobile Phone	:	Manufacturer: NOKIA
	:	M/N: N920 S/N: 356355051634804 CE , FCC, DOC
Adapter	:	Manufacturer: SAMSUNG M/N: ETA-U90CBC S/N: RT6FB17ZS/B-E Input: 100-240V~50/60Hz 0.35A Output: DC 5V, 2000mA

1.4. Description of Test Modes

To investigate the maximum EMI emission characteristics generated from EUT, the test system was pre-scanning tested based on the consideration of following EUT operation mode or test configuration mode which possibly have effect on EMI emission level. Each of these EUT operation mode(s) or test configuration mode(s) mentioned above was evaluated respectively.

Pretest Mode	Description
Mode 1	CH01
Mode 2	CH10
Mode 3	CH20
Mode 4	Keeping TX mode

For Conducted Emission	
Final Test Mode	Description
Mode 1	Keeping TX mode

For Radiated Emission	
Final Test Mode	Description
Mode 1	CH01
Mode 2	CH10
Mode 3	CH20

1.5. List of channels

Channel	Freq. (MHz)	Channel	Freq. (MHz)	Channel	Freq. (MHz)	Channel	Freq. (MHz)
1	0.110	6	0.135	11	0.160	16	0.185
2	0.115	7	0.140	12	0.165	17	0.190
3	0.120	8	0.145	13	0.170	18	0.195
4	0.125	9	0.150	14	0.175	19	0.200
5	0.130	10	0.155	15	0.180	20	0.205

1.6. Description Of Test Setup

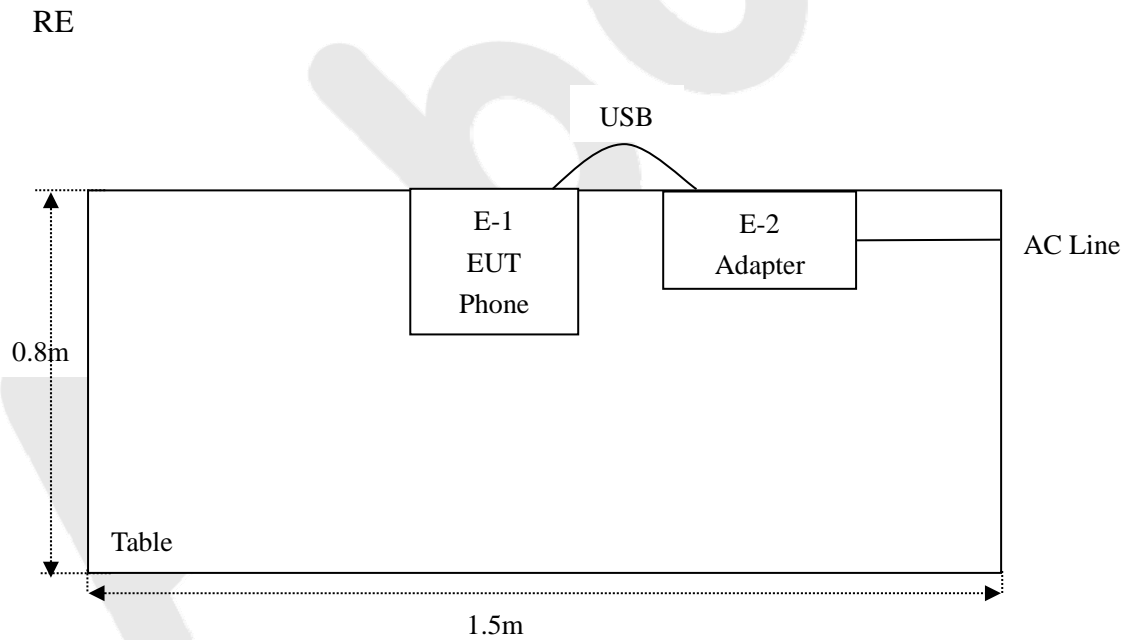
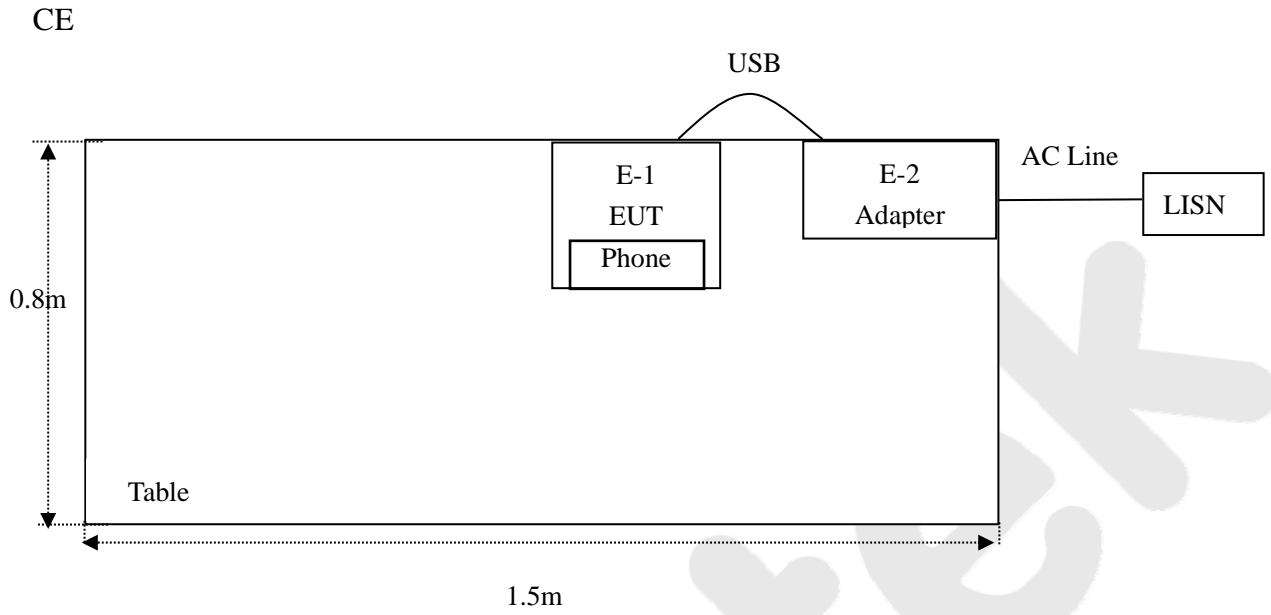

1.7. Test Equipment List

Item	Equipment	Manufacturer	Model No.	Serial No.	Last Cal.	Cal. Interval
1.	L.I.S.N. Artificial Mains Network	Rohde & Schwarz	ENV216	100055	May 27, 2017	1 Year
2.	EMI Test Receiver	Rohde & Schwarz	ESCI	100627	May 27, 2017	1 Year
3.	RF Switching Unit	Compliance Direction	RSU-M2	38303	May 27, 2017	1 Year
4.	Spectrum Analysis	Agilent	E4407B	US39390582	May 27, 2017	1 Year
5.	Preamplifier	SKET Electronic	BK1G18G30 D	KD17503	May 27, 2017	1 Year
6.	EMI Test Receiver	Rohde & Schwarz	ESPI	101604	May 27, 2017	1 Year
7.	Double Ridged Horn Antenna	Instruments corporation	GTH-0118	351600	May 31, 2017	1 Year
8.	Bilog Broadband Antenna	Schwarzbeck	VULB9163	VULB 9163-289	May 31, 2017	1 Year
9.	Loop Antenna	Schwarzbeck	HFH2-Z2	100047	Apr. 03, 2017	1 Year
10.	Pre-amplifier	SONOMA	310N	186860	May 27, 2017	1 Year
11.	EMI Test Software EZ-EMC	SHURPLE	N/A	N/A	N/A	N/A
12.	Power Sensor	DAER	RPR3006W	15I00041SN045	May 27, 2017	1 Year
13.	Power Sensor	DAER	RPR3006W	15I00041SN046	May 27, 2017	1 Year
14.	MXA Spectrum Analysis	Agilent	N9020A	MY51170037	May 27, 2017	1 Year
15.	MXG RF Vector Signal Generator	Agilent	N5182A	MY48180656	May 27, 2017	1 Year
16.	Signal Generator	Agilent	E4421B	MY41000743	May 27, 2017	1 Year
17.	DC Power supply	IVYTECH	IV6003	1601D6030007	May 26, 2017	1 Year
18.	TEMP&HUMI PROGRAMMABLE CHAMBER	Sertep	ZJ-HWHS80 B	ZJ-17042804	Mar. 03, 2017	1 Year

1.8. Measurement Uncertainty

Radiation Uncertainty	:	Ur = 4.1 dB (Horizontal)
		Ur = 4.3 dB (Vertical)
Conduction Uncertainty	:	Uc = 3.4dB

1.9. Description of Test Facility

The test facility is recognized, certified, or accredited by the following organizations:

FCC-Designation No.: CN5023

Shenzhen Anbotek Compliance Laboratory Limited, EMC Laboratory has been registered and fully described in a report filed with the (FCC) Federal Communications Commission. The acceptance letter from the FCC is maintained in our files. Designation CN5023, July 31, 2017.

ISED-Registration No.: 8058A-1

Shenzhen Anbotek Compliance Laboratory Limited, EMC Laboratory has been registered and fully described in a report filed with the (ISED) Innovation, Science and Economic Development Canada. The acceptance letter from the ISED is maintained in our files. Registration 8058A-1, June 13, 2016.

Test Location

All Emissions tests were performed at
Shenzhen Anbotek Compliance Laboratory Limited. at 1/F., Building 1, SEC Industrial Park, No.0409 Qianhai Road, Nanshan District, Shenzhen, Guangdong, China

2. Summary of Test Results

Standard Section	Test Item	Result
FCC Part 15, Paragraph 15.207	Conducted Emission Test	PASS
FCC Part 15, Paragraph 15.209(a)(f)	Spurious Emission	PASS

Anbotek

3. Conducted Emission Test

3.1. Test Standard and Limit

Test Standard	FCC Part15 Section 15.207		
Test Limit	Frequency	Maximum RF Line Voltage (dBuV)	
		Quasi-peak Level	Average Level
	150kHz~500kHz	66 ~ 56 *	56 ~ 46 *
	500kHz~5MHz	56	46
5MHz~30MHz	60	50	

Remark: (1) *Decreasing linearly with logarithm of the frequency.
(2) The lower limit shall apply at the transition frequency.

3.2. Test Setup

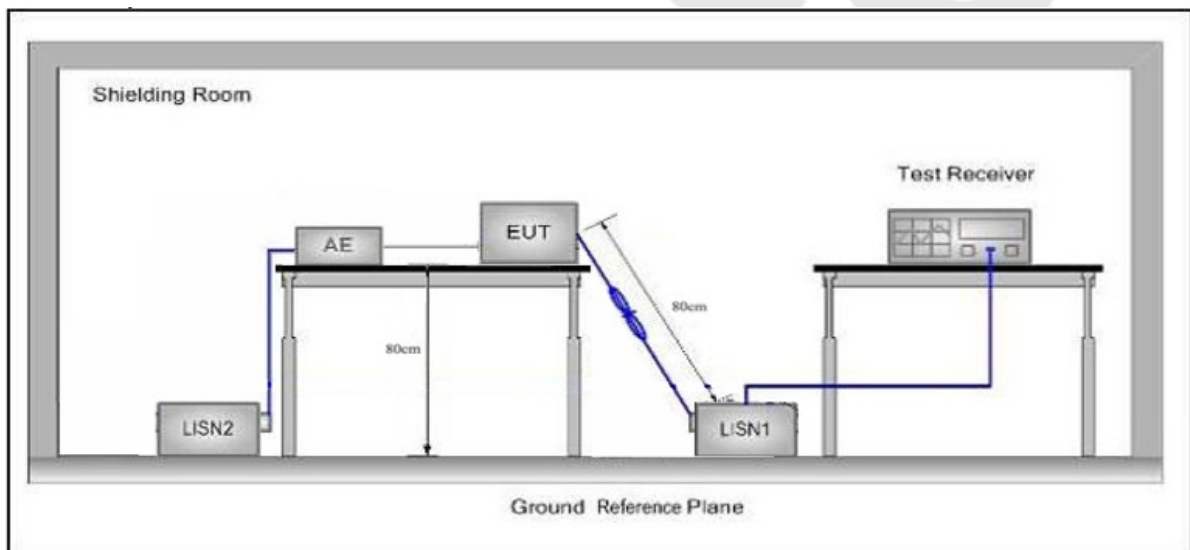

3.3. Test Procedure

The EUT system is connected to the power mains through a line impedance stabilization network (L.I.S.N.). This provides a 50ohm coupling impedance for the EUT system. Please refer the block diagram of the test setup and photographs. Both sides of AC line are checked to find out the maximum conducted emission. In order to find the maximum emission levels, the relative positions of equipment and all of the interface cables shall be changed according to FCC ANSI C63.10-2013 on Conducted Emission Measurement.

The bandwidth of test receiver (ESCI) set at 9kHz.

The frequency range from 150kHz to 30MHz is checked.

3.4. Test Data

Please to see the following pages

Conducted Emission Test Data

Test Site: 1# Shielded Room
 Operating Condition: Keeping TX mode
 Test Specification: AC 120V, 60Hz for adapter
 Comment: Live Line
 Tem.:25°C Hum.:50%

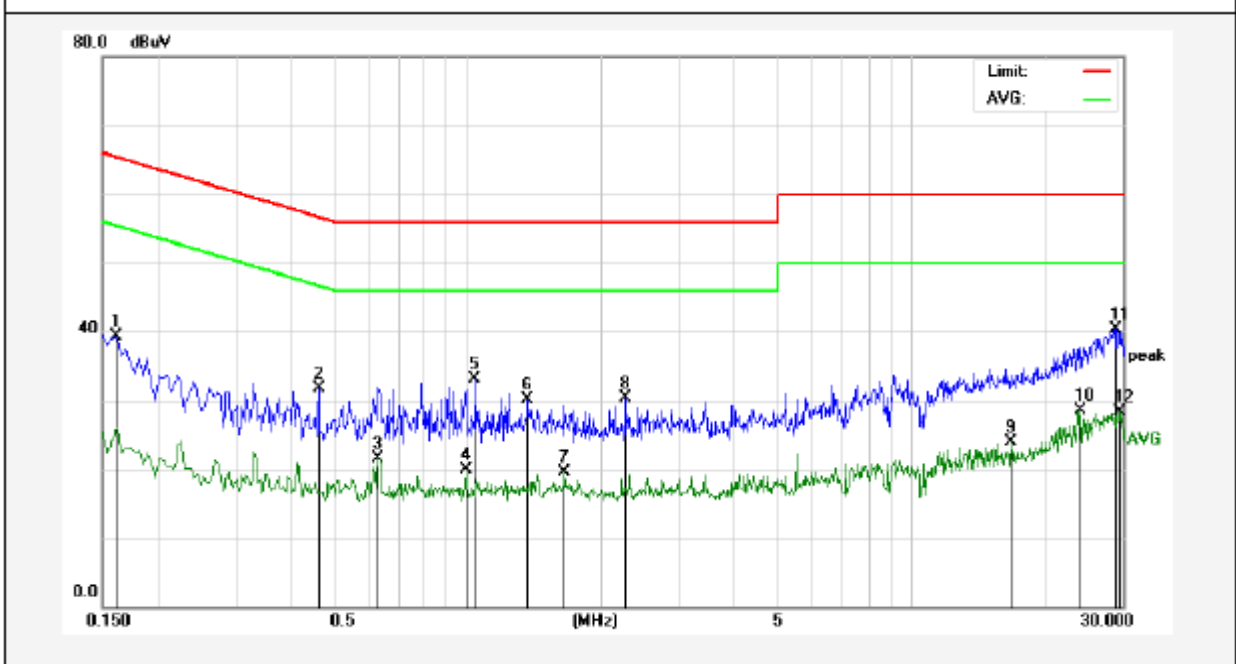

No.	Freq. (MHz)	Reading (dBuV)	Factor (dB)	Result (dBuV)	Limit dBuV	Over Limit (dB)	Detector	Remark
1	0.1620	19.34	19.90	39.24	65.36	-26.12	QP	
2	0.4620	11.75	19.96	31.71	56.66	-24.95	QP	
3	0.6300	1.48	20.02	21.50	46.00	-24.50	AVG	
4	0.9940	-0.25	20.12	19.87	46.00	-26.13	AVG	
5	1.0420	12.89	20.12	33.01	56.00	-22.99	QP	
6	1.3700	9.96	20.13	30.09	56.00	-25.91	QP	
7	1.6580	-0.64	20.13	19.49	46.00	-26.51	AVG	
8	2.2780	10.16	20.15	30.31	56.00	-25.69	QP	
9	16.7500	3.52	20.29	23.81	50.00	-26.19	AVG	
10	24.0940	8.25	20.29	28.54	50.00	-21.46	AVG	
11	28.9620	20.07	20.27	40.34	60.00	-19.66	QP	
12	29.6340	8.13	20.27	28.40	50.00	-21.60	AVG	

Conducted Emission Test Data

Test Site: 1# Shielded Room
 Operating Condition: Keeping TX mode
 Test Specification: AC 120V, 60Hz for adapter
 Comment: Neutral Line
 Tem.:25°C Hum.:50%

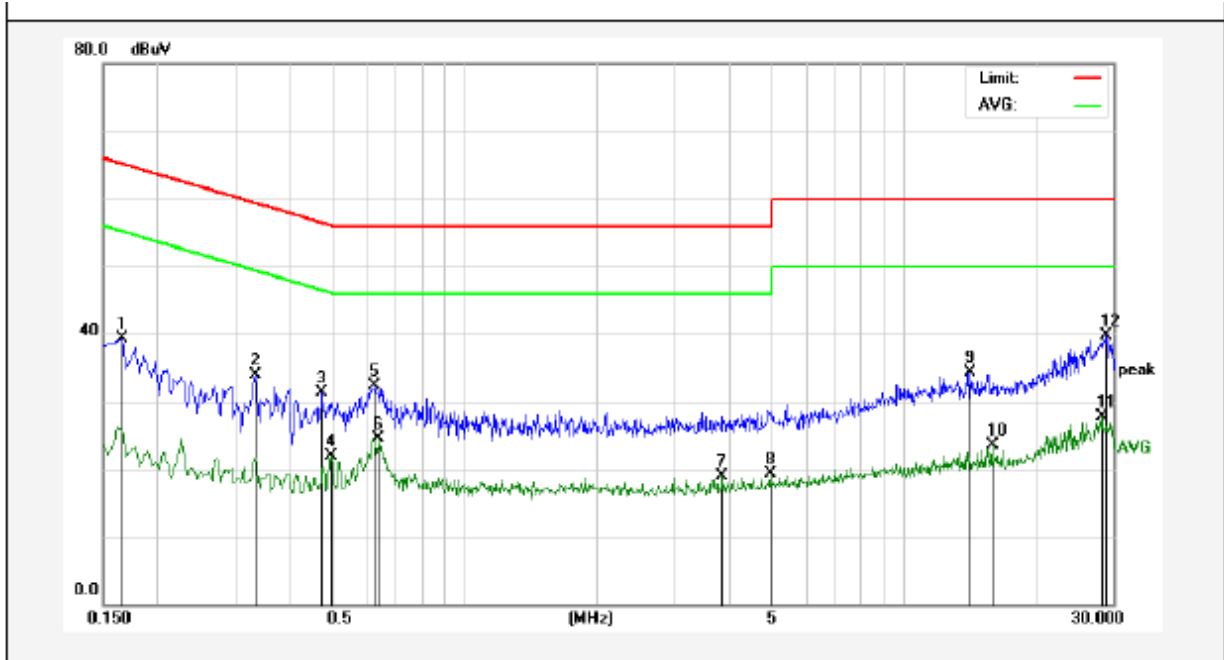

No.	Freq. (MHz)	Reading (dBuV)	Factor (dB)	Result (dBuV)	Limit dBuV	Over Limit (dB)	Detector	Remark
1	0.1660	19.40	19.90	39.30	65.15	-25.85	QP	
2	0.3339	13.93	19.91	33.84	59.35	-25.51	QP	
3	0.4740	11.30	19.97	31.27	56.44	-25.17	QP	
4	0.4980	1.93	19.98	21.91	46.03	-24.12	AVG	
5	0.6260	12.25	20.02	32.27	56.00	-23.73	QP	
6	0.6380	4.45	20.02	24.47	46.00	-21.53	AVG	
7	3.8700	-1.29	20.18	18.89	46.00	-27.11	AVG	
8	4.9780	-0.84	20.21	19.37	46.00	-26.63	AVG	
9	14.1540	13.98	20.27	34.25	60.00	-25.75	QP	
10	15.9220	3.28	20.27	23.55	50.00	-26.45	AVG	
11	28.2100	7.49	20.27	27.76	50.00	-22.24	AVG	
12	28.7580	19.43	20.27	39.70	60.00	-20.30	QP	

Conducted Emission Test Data

Test Site: 1# Shielded Room
 Operating Condition: Keeping TX mode
 Test Specification: AC 240V, 60Hz for adapter
 Comment: Live Line
 Tem.:25°C Hum.:50%

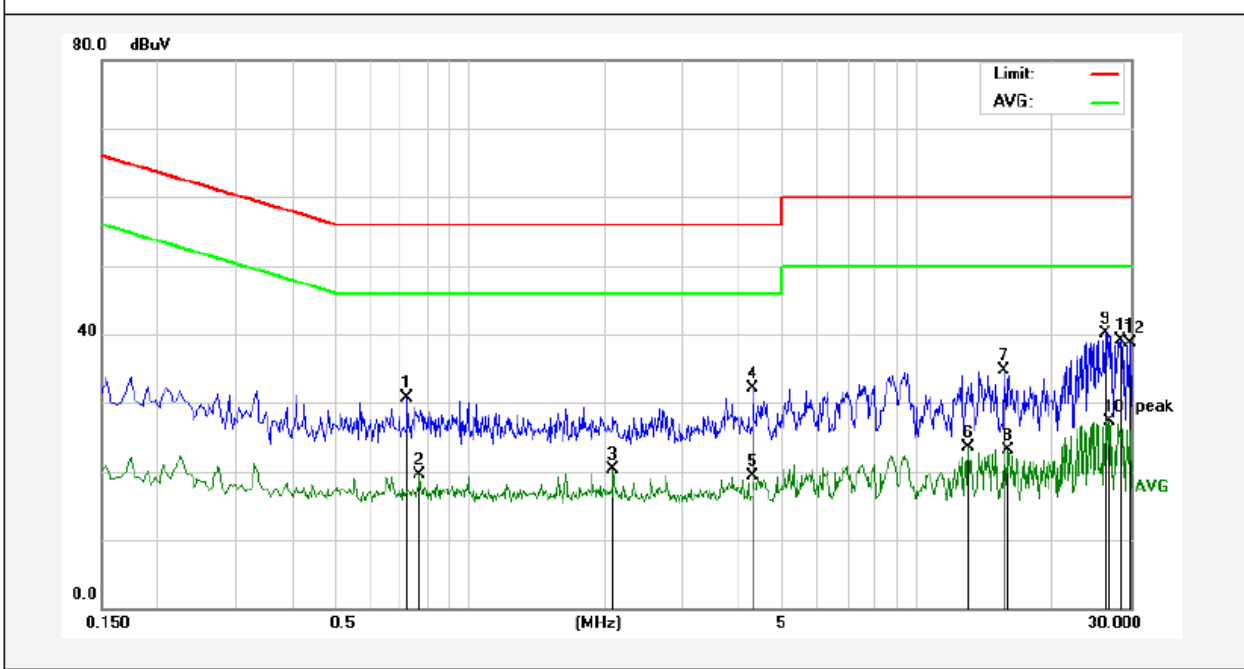

No.	Freq. (MHz)	Reading (dBuV)	Factor (dB)	Result (dBuV)	Limit dBuV	Over Limit (dB)	Detector	Remark
1	0.7260	10.60	20.05	30.65	56.00	-25.35	QP	
2	0.7740	-0.59	20.06	19.47	46.00	-26.53	AVG	
3	2.0980	0.09	20.14	20.23	46.00	-25.77	AVG	
4	4.3100	12.00	20.19	32.19	56.00	-23.81	QP	
5	4.3100	-0.85	20.19	19.34	46.00	-26.66	AVG	
6	13.0380	3.15	20.29	23.44	50.00	-26.56	AVG	
7	15.6140	14.39	20.27	34.66	60.00	-25.34	QP	
8	15.9060	2.84	20.27	23.11	50.00	-26.89	AVG	
9	26.3060	19.92	20.28	40.20	60.00	-19.80	QP	
10	26.9660	6.96	20.28	27.24	50.00	-22.76	AVG	
11	28.5300	18.79	20.27	39.06	60.00	-20.94	QP	
12	29.8500	18.50	20.27	38.77	60.00	-21.23	QP	

Conducted Emission Test Data

Test Site: 1# Shielded Room
 Operating Condition: Keeping TX mode
 Test Specification: AC 240V, 60Hz for adapter
 Comment: Neutral Line
 Tem.:25°C Hum.:50%

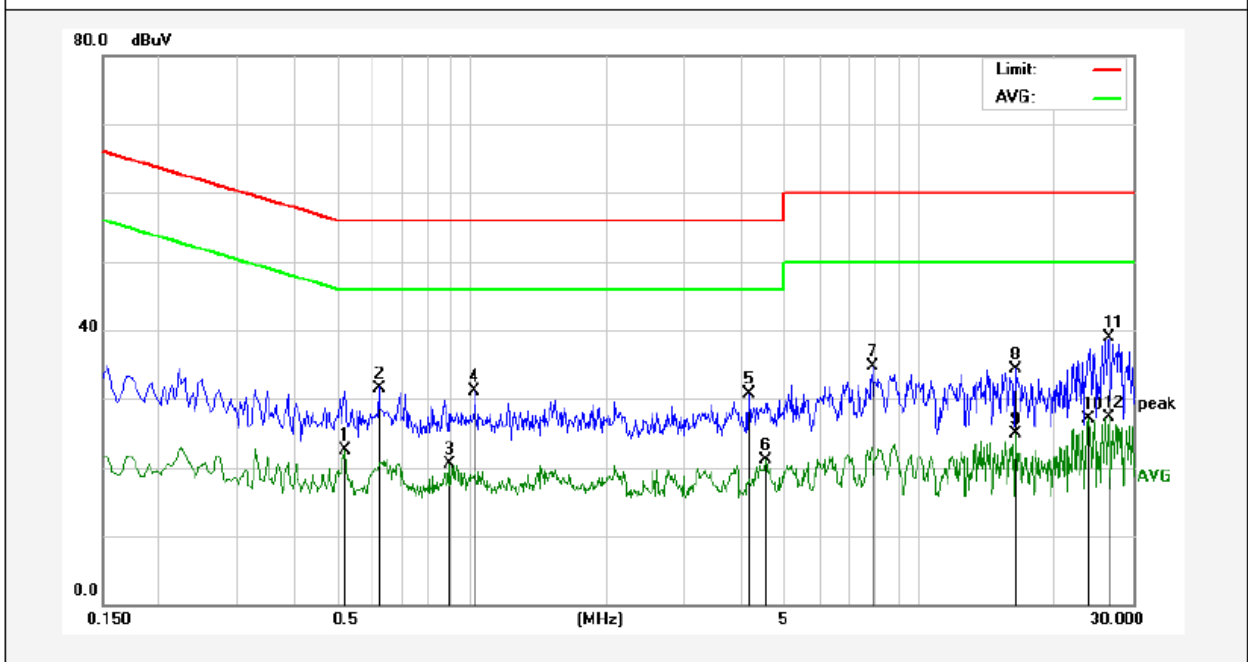

No.	Freq. (MHz)	Reading (dBuV)	Factor (dB)	Result (dBuV)	Limit dBuV	Over Limit (dB)	Detector	Remark
1	0.5220	2.50	19.99	22.49	46.00	-23.51	AVG	
2	0.6220	11.58	20.02	31.60	56.00	-24.40	QP	
3	0.8900	0.39	20.09	20.48	46.00	-25.52	AVG	
4	1.0180	10.99	20.12	31.11	56.00	-24.89	QP	
5	4.1620	10.53	20.18	30.71	56.00	-25.29	QP	
6	4.5340	0.99	20.19	21.18	46.00	-24.82	AVG	
7	7.8540	14.40	20.28	34.68	60.00	-25.32	QP	
8	16.4740	14.10	20.28	34.38	60.00	-25.62	QP	
9	16.4740	4.53	20.28	24.81	50.00	-25.19	AVG	
10	23.8860	6.81	20.29	27.10	50.00	-22.90	AVG	
11	26.5340	18.61	20.28	38.89	60.00	-21.11	QP	
12	26.5340	7.00	20.28	27.28	50.00	-22.72	AVG	

4. Radiation Spurious Emission and Band Edge

4.1. Test Standard and Limit

Test Standard	FCC Part15 C Section 15.209 and 15.205				
Test Limit	Frequency (MHz)	Field strength (microvolt/meter)	Limit (dBuV/m)	Remark	Measurement distance (m)
	0.009MHz~0.490MHz	2400/F(kHz)	-	-	300
	0.490MHz-1.705MHz	24000/F(kHz)	-	-	30
	1.705MHz-30MHz	30	-	-	30
	30MHz~88MHz	100	40.0	Quasi-peak	3
	88MHz~216MHz	150	43.5	Quasi-peak	3
	216MHz~960MHz	200	46.0	Quasi-peak	3
	960MHz~1000MHz	500	54.0	Quasi-peak	3
	Above 1000MHz	500	54.0	Average	3
-		74.0	Peak	3	

Remark:

(1)The lower limit shall apply at the transition frequency.

(2) 15.35(b), Unless otherwise specified, the limit on peak radio frequency emissions is 20dB above the maximum permitted average emission limit applicable to the equipment under test. This peak limit applies to the total peak emission level radiated by the device.

4.2. Test Setup

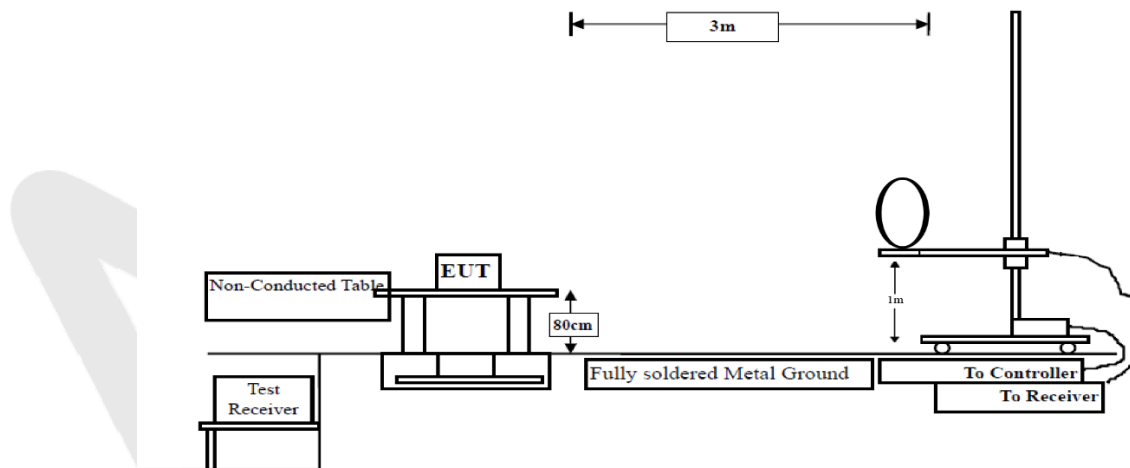

Figure 1. Below 30MHz

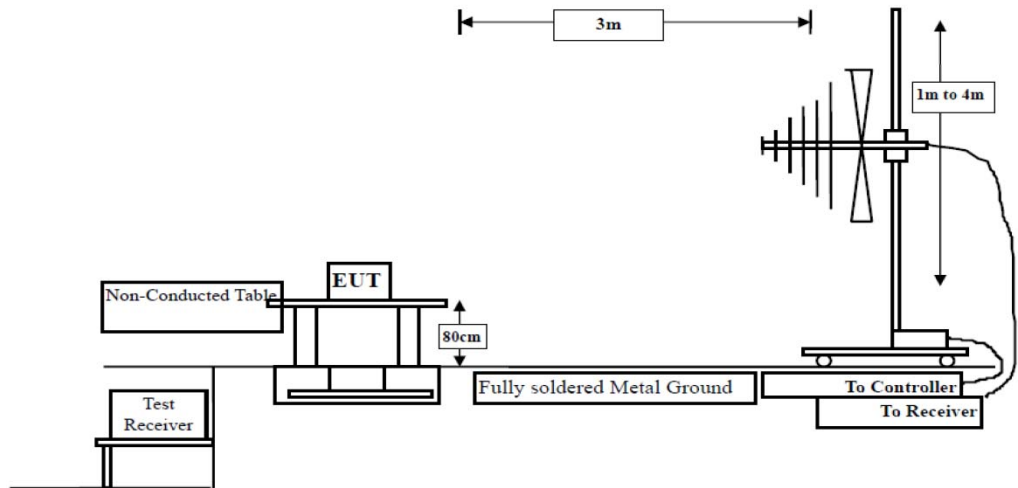

Figure 2. 30MHz to 1GHz

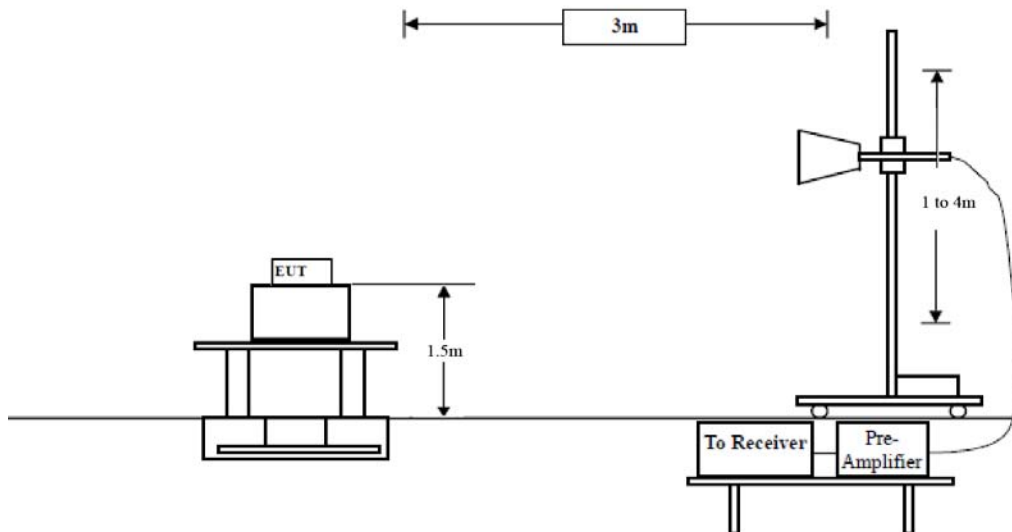

Figure 3. Above 1 GHz

4.3. Test Procedure

For below 1GHz: The EUT is placed on a turntable, which is 0.8m above the ground plane.

For above 1GHz: The EUT is placed on a turntable, which is 1.5m above the ground plane.

The turn table can rotate 360 degrees to determine the position of the maximum emission level. The EUT is set 3 meters away from the receiving antenna which is mounted on a antenna tower. The antenna can be moved up and down from 1 to 4 meters to find out the maximum emission level. Rotated the EUT through three orthogonal axes to determine the maximum emissions, both horizontal and vertical polarization of the antenna are set on test. The EUT is tested in 9*6*6 Chamber. The device is evaluated in xyz orientation.

For 9kHz to 150kHz, Set the spectrum analyzer as:

RBW = 200Hz, VBW =1kHz, Detector= Quasi-Peak, Trace mode= Max hold, Sweep- auto couple.

For 150kHz to 30MHz, Set the spectrum analyzer as:

RBW = 9KHz, VBW =30kHz, Detector= Quasi-Peak, Trace mode= Max hold, Sweep- auto couple.

For 30MHz to 1000MHz, Set the spectrum analyzer as:

RBW = 100kHz, VBW =300kHz, Detector= Quasi-Peak, Trace mode= Max hold, Sweep- auto couple.

4.4. Test Data

PASS

Anbotek

Test Results

(Between 9KHz – 30MHz)

Job No.:	0217090003W		
Standard:	FCC PART15 C_3m	Power Source:	AC120V/60Hz for adapter
Test item:	Radiation Test	Temp.(C)/Hum.(%RH):	24.4(C)/50%RH
Test Mode:	TX Mode	Distance:	3m

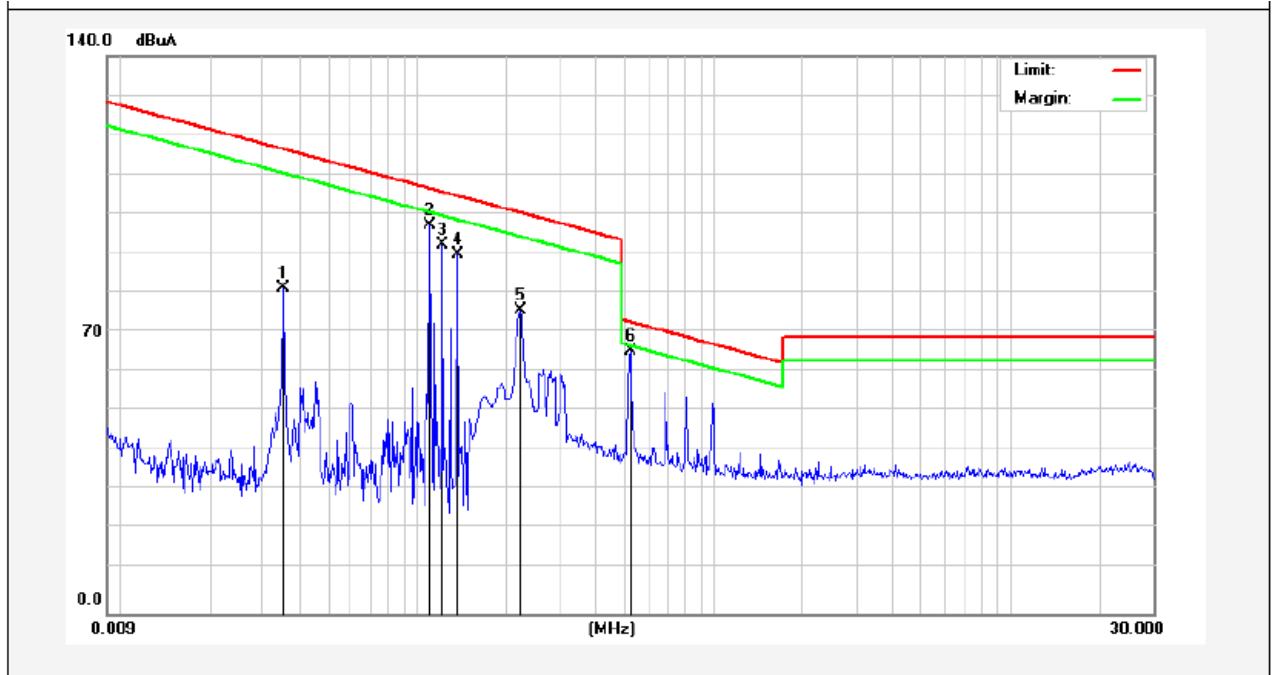

Frequency (MHz)	Read Level (dBuV)	Antenna Factor (dB/m)	Cable Loss (dB)	Preamp Factor (dB)	Level (dBuV/m)	Limit (dBuV/m)	Over Limit (dB)	Detector	degree
									(dgc)
0.0355	59.92	19.30	2.53	0	81.75	136.50	-54.75	Peak	15
0.0355	57.11	19.30	2.53	0	78.94	116.50	-37.56	AV	15
0.1104	75.53	19.30	2.53	0	97.36	133.60	-36.24	Peak	33
0.1104	73.74	19.30	2.53	0	95.57	113.60	-18.03	AV	33
0.1216	70.68	19.29	2.54	0	92.51	126.08	-33.57	Peak	124
0.1216	68.69	19.29	2.54	0	90.52	106.08	-15.56	AV	124
0.1369	68.24	19.36	2.55	0	90.15	120.79	-30.64	Peak	101
0.1369	66.71	19.36	2.55	0	88.62	100.79	-12.17	AV	101
0.2220	53.85	19.63	2.59	0	76.07	117.21	-41.14	Peak	324
0.2220	51.67	19.63	2.59	0	73.89	97.21	-23.32	AV	324
0.5220	43.11	20.32	2.60	0	66.03	72.86	-6.83	QP	0

Remark: According to FCC PART 15.209 (d), the emission limits for the frequency bands 9–90 kHz, 110–490 kHz and above 1000 MHz, Radiated emission limits in these three bands are based on measurements employing an average detector.

(Between 30MHz –1000 MHz)

Job No.:	0217090003W	Polarization:	Horizontal
Standard:	FCC PART15 C _3m	Power Source:	AC 120V/ 60Hz for adapter
Test item:	Radiation Test	Temp.(C)/Hum.(%RH):	24.4(C)/50%RH
Test Mode:	TX Mode	Distance:	3m

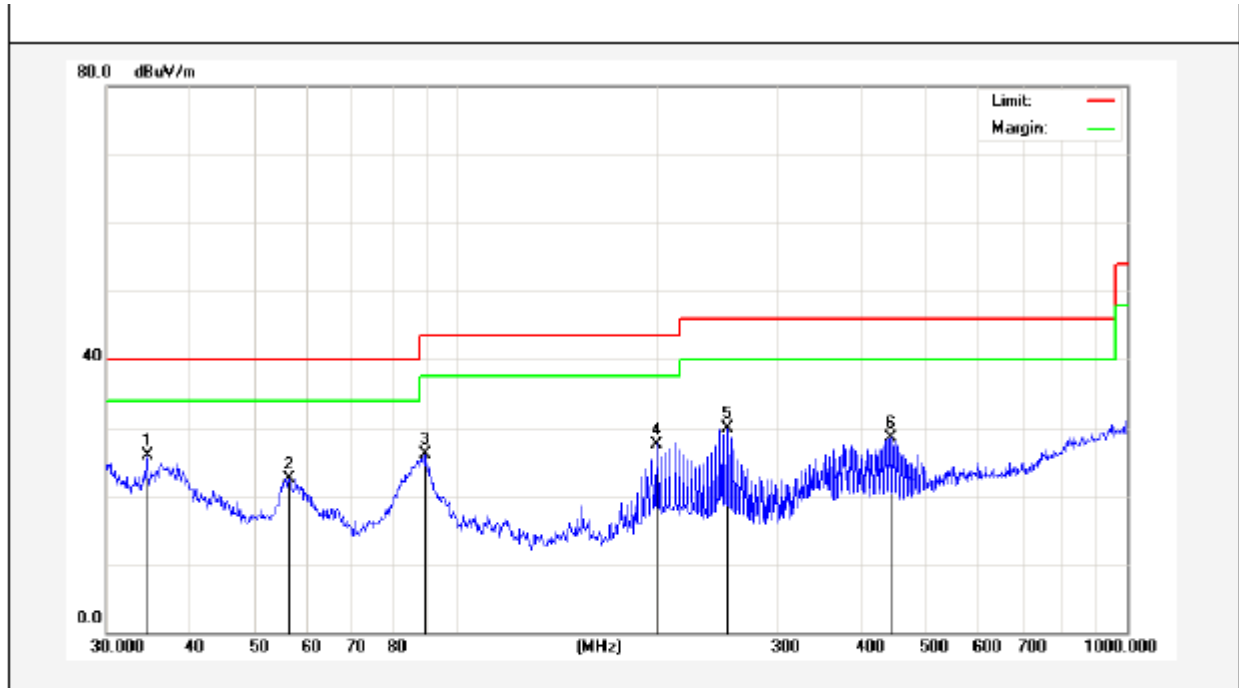

No.	Freq. (MHz)	Reading (dBuV/m)	Factor (dB/m)	Result (dBuV/m)	Limit (dBuV/)	Over Limit (dB)	Detector	Height (cm)	degree (deg)	Remark
1	34.5173	40.67	-14.78	25.89	40.00	-14.11	QP	300	13	
2	56.1974	37.58	-15.05	22.53	40.00	-17.47	QP	300	47	
3	89.5899	48.79	-22.67	26.12	43.50	-17.38	QP	300	102	
4	198.5880	48.48	-20.88	27.60	43.50	-15.90	QP	300	134	
5	252.9482	48.59	-18.67	29.92	46.00	-16.08	QP	300	167	
6	444.8514	40.78	-12.18	28.60	46.00	-17.40	QP	300	201	



Job No.:	0217090003W	Plarization:	Vertical
Standard:	FCC PART15 C _3m	Power Source:	AC 120V/60Hz for adapter
Test item:	Radiation Test	Temp.(C)/Hum.(%RH):	24.4(C)/50%RH
Test Mode:	TX Mode	Distance:	3m

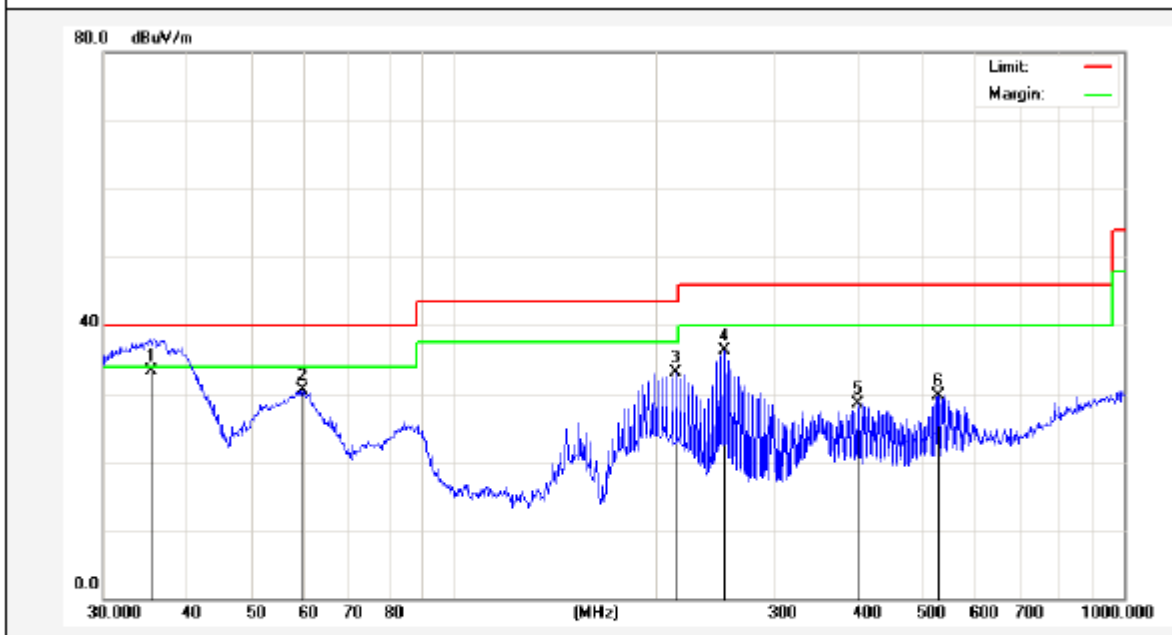

No.	Freq. (MHz)	Reading (dBuV/m)	Factor (dB/m)	Result (dBuV/m)	Limit (dBuV/)	Over Limit (dB)	Detector	Height (cm)	degree (deg)	Remark
1	35.4291	47.61	-14.23	33.38	40.00	-6.62	QP	300	14	
2	59.4405	45.94	-15.34	30.60	40.00	-9.40	QP	300	63	
3	214.5143	48.43	-15.32	33.11	43.50	-10.39	QP	300	102	
4	252.9482	50.38	-14.03	36.35	46.00	-9.65	QP	300	164	
5	400.4319	40.35	-11.86	28.49	46.00	-17.51	QP	300	234	
6	528.2458	40.25	-10.47	29.78	46.00	-16.22	QP	300	301	

APPENDIX I -- TEST SETUP PHOTOGRAPH

Photo of Conducted Emission Measurement



Photo of Radiation Emission Test

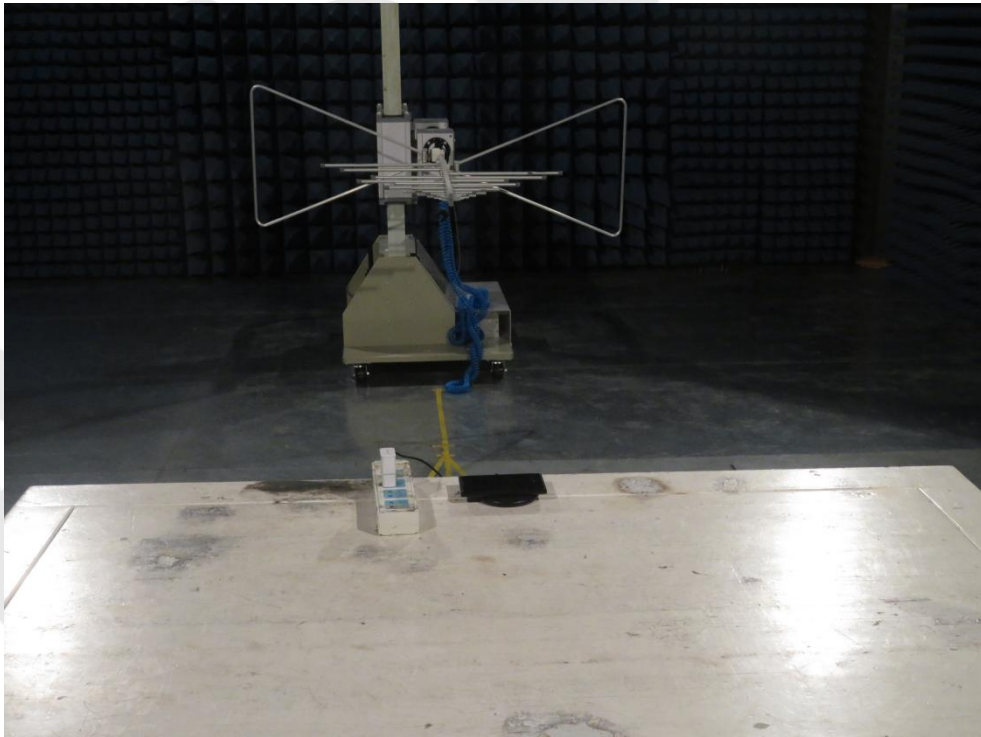

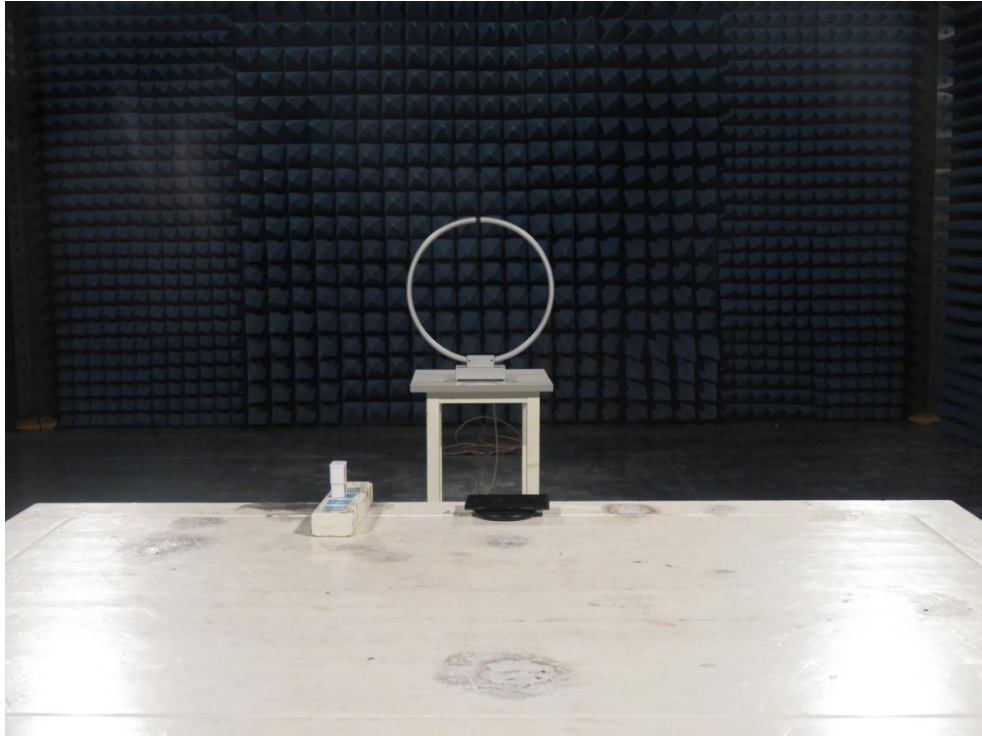

Anbotek

APPENDIX II -- EXTERNAL PHOTOGRAPH

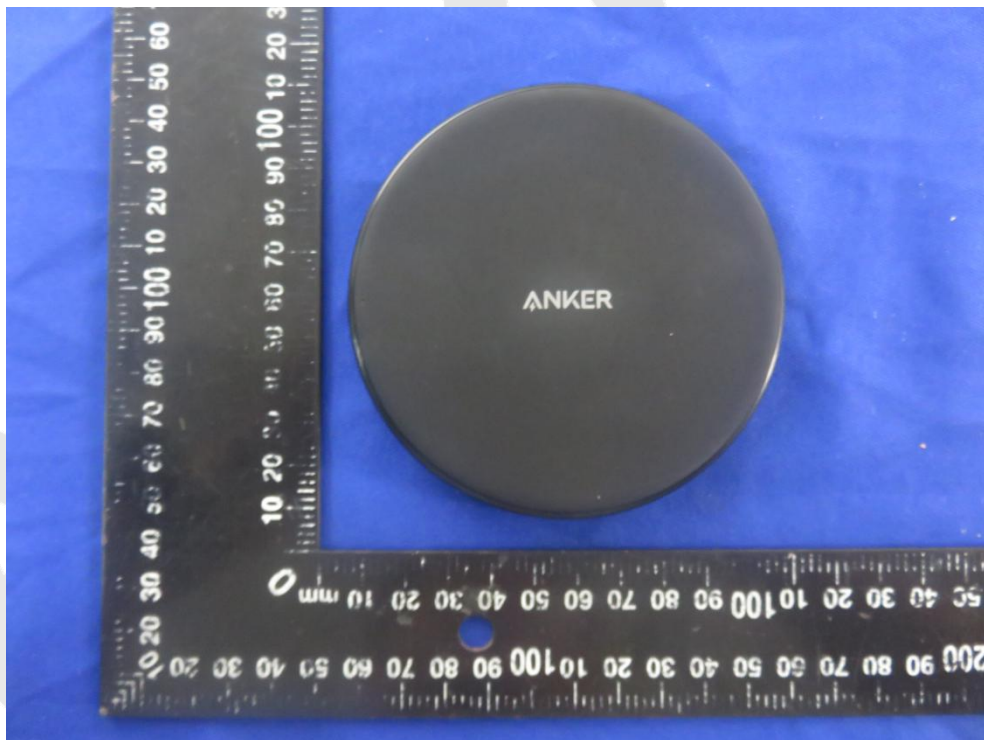







Anbotek

APPENDIX III -- INTERNAL PHOTOGRAPH

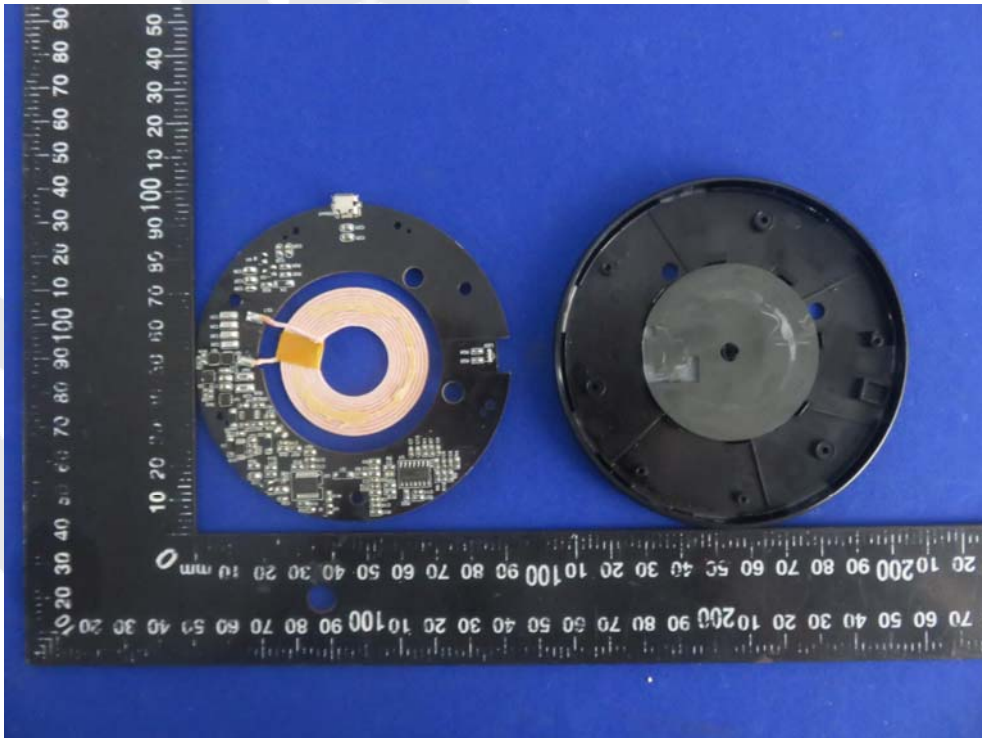
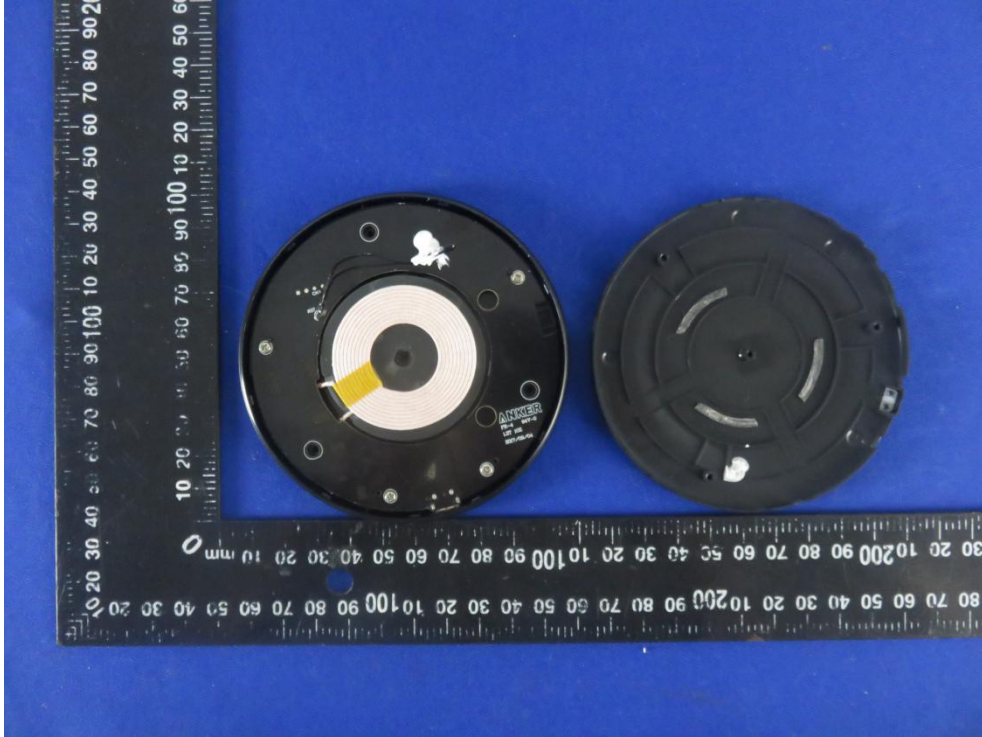

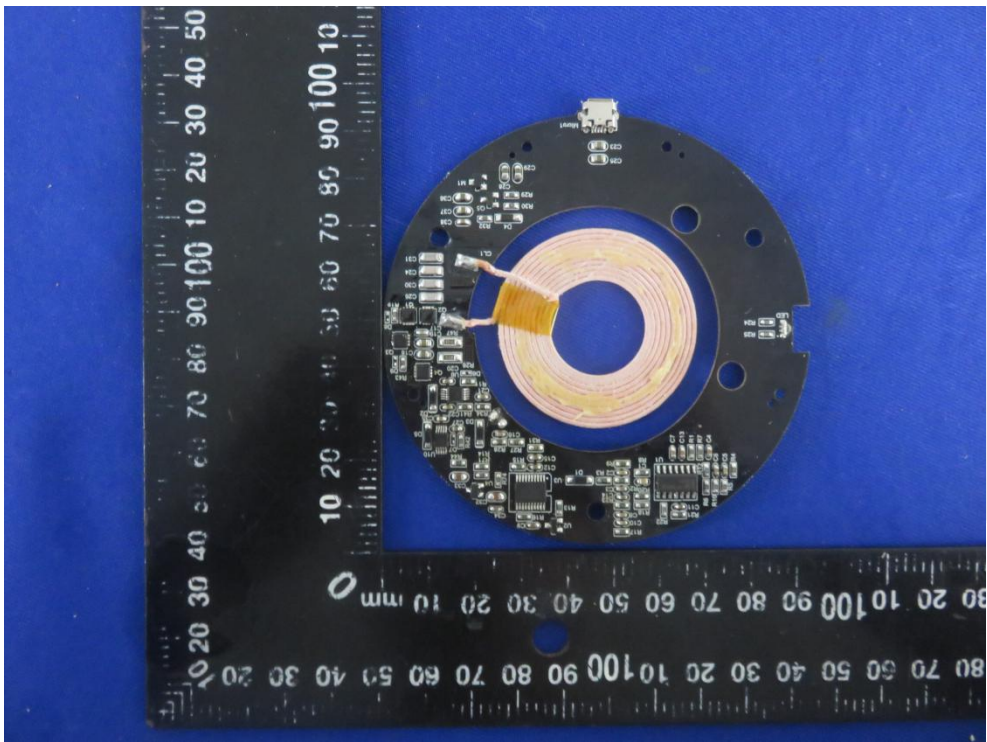

Inductive loop coil Antenna

