

# 智能跳绳

## 使用说明书

蓝牙智能跳绳 跳出健康好身材

### 产品介绍

感谢您选择智能跳绳

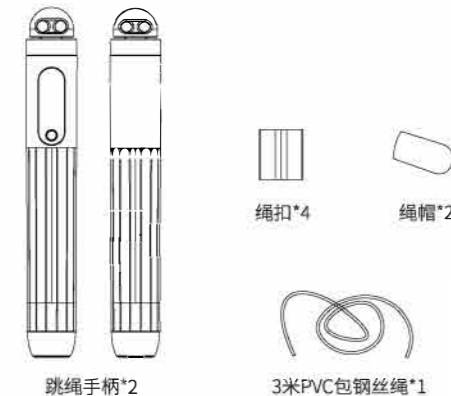

### 基本介绍

1. 本产品2节AAA7号干电池供电。
2. 由蓝牙连接APP传输数据同步保存。
3. 基本功能为跳绳计数、计时。
4. 按键切换三种跳绳模式。

### 装配方式

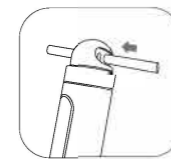

①将绳子按此方向穿入任一孔内。



②调节到适合的尺寸后,再穿入另外一个孔。

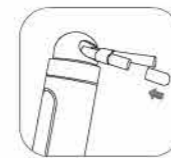

③稍微用力拉紧,使绳子不容易松动,再扣上绳扣和套上绳帽。

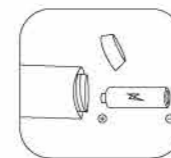

④电池安装:打开后盖,正极朝里,装入电池。

### 调节方式

将两个手柄握住,双脚并拢踩住跳绳,手臂呈90度角拉直代表符合长度。(用户也可以根据自己喜好调节长短)



腰部以上即为符合

### 跳绳的正确姿势

身体自然站立,双脚踝稍微错开,上臂紧贴身体,小臂向两侧伸开,手腕发力摇动手柄跳动,腿部略微弯曲一些,跳动时切忌不要用脚后跟和全脚掌着地。

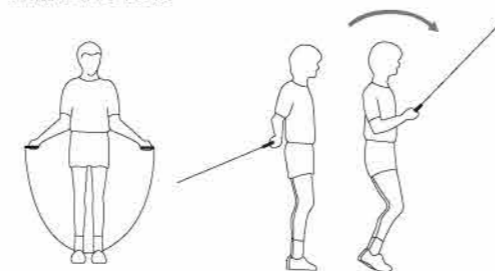

### 开始使用

安装智能跳绳 APP

请扫描下方二维码下载并安装智能跳绳APP JCSkip (注意:通过其他渠道的APP可能会导致无法正常连接和使用) 请确认你的设备符合以下要求:

- 运行iOS10.0及以上的iPhone或iPad设备。
- 运行Anduoid5.1及以上系统并配备蓝牙4.0的手机设备。



扫描二维码

下载官方<智能跳绳APP"JCSkip">

### 蓝牙配对连接

- ① 打开手机蓝牙,保持跳绳为开机状态。
- ② 打开JCSkip APP,进入主界面,点击右上角设备图片进入扫描界面。
- ③ 当出现扫描到的设备列表,点击要连接的设备,手机将自动连接跳绳。
- ④ 连接成功后,跳绳屏幕左上角会显示蓝牙图标,你可以点击APP主界面的同步图标同步数据。



### 跳绳按键功能介绍

1. 长按按键2秒开机,开机后跳绳默认进入自由跳模式。
2. 开机后2分钟内无使用,主机将自动进入休眠省电模式,这个模式下可以单击按键唤醒跳绳。
3. 你可以通过长按按键切换不同的跳绳模式(自由跳,倒计时跳,倒计时跳)
4. 自由跳模式,单击按键可以切换查看当前跳绳数和时间,当天总跳绳数和总跳绳时间,系统时间。
5. 自由跳模式下,长按按键可以切换到倒计时模式以及倒计时模式。
6. 倒计时模式下,单击按键可设置倒计时的时间,默认从1分钟开始到10分钟循环切换。目标完成后,跳绳会蜂鸣3次和震动3次提醒。
7. 倒计时模式下,单击按键可设置倒计时数量,默认为100次到2000次循环切换。目标完成后,跳绳会蜂鸣3次和震动3次提醒。
8. 关机,用户可长按按键10秒关机,跳绳在5分钟内无使用会自动关机。

### 温馨建议

1. 跳绳时请穿着减震的运动鞋,可以更好地保护脚踝及脚掌。
2. 请在跳绳前,做一些热身运动,帮助身体血液循环加快,能使筋腱更灵活,避免关节,韧带和肌肉损伤。
3. 请在运动后,做一些拉伸运动,尤其是对腿部的拉伸,可以缓解肌肉紧张或酸痛。
4. 请尽量选择软硬适中的场地如:草坪、塑胶运动场、健身房等,粗糙地面会增大绳子的阻力,也会加快绳子磨损。
5. 请尽量选择空旷的场地,以免伤到他人。

### 产品信息

产品名称:智能蓝牙跳绳  
产品型号: 2023  
产品尺寸:174.8\*25.6 \*25.6mm  
产品重量:121g  
主要材料:PC+ABS PVC +金属  
供电方式: 两节七号电池  
APP支持:APP支持Android 5.1及以上 iOS 9.0及以上  
包装清单:手柄x2 3米PVC包钢丝绳x1 绳子扣环x4 绳头帽x2 说明书x1

### FCC声明

未经负责合规方明确批准的更改或修改可能会使用户丧失操作设备的权限。

本设备经测试证明符合FCC规则第15部分中关于B类数字设备的限制。这些限制旨在为住宅安装中的有害干扰提供合理的保护。本设备会产生使用并辐射射频能量,如果未按照说明进行安装和使用,可能会对无线电通信造成有害干扰。但是,不能保证在特定安装中不会发生干扰。如果此设备确实对无线电或电视接收造成有害干扰(可以通过打开和关闭设备来确定),则鼓励用户尝试通过以下一种或多种措施来消除干扰:

- 重新调整或摆放接收天线。
- 增加设备和接收器之间的距离。
- 将设备连接到与接收器不同电路的插座上。
- 咨询经销商或经验丰富的广播/电视技术人员以寻求帮助。

此设备符合FCC规则的第15部分。操作必须符合以下两个条件:

- (1) 此设备不会造成有害干扰,并且
- (2) 此设备必须接受收到的任何干扰,包括可能导致意外操作的干扰。

# bluetooth smart skipping rope User Manual

Smart Skip Healthy Life

## Product Information

Thank you for using Smart Skip

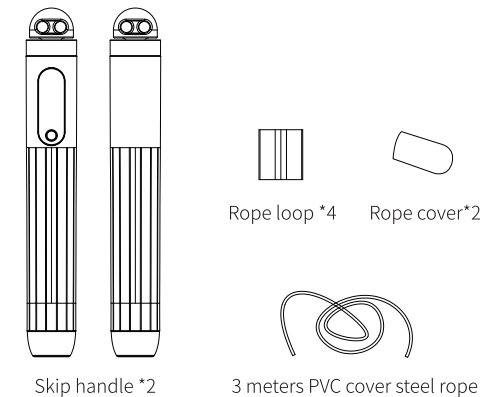

## Product Introduction

1. Smart Skip powered by 2\*AAA batteries.
2. Sync the data via BT4.0 use JCSkip APP.
3. Count the skips and time during skipping.
4. Press the button change different skip mode.

## How to assemble the Smart Skip

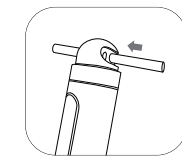

- ① Put the rope inside one of the rope hole in the handle .

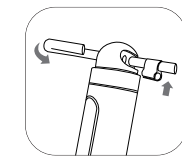

- ② Adjust the rope' s length to fit you height.

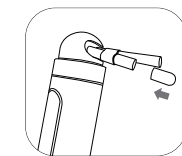

- ③ Pull and fasten both side of the rope , then put the loops and rope cover in both side of the handle.

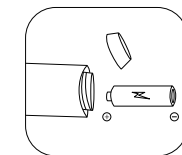

- ④ Battery installation: Open the back cover, with the positive pole facing inward, and insert the battery.

## How to adjust the rope length

Hold both of the handle with your hands , and put your feet on the rope ,then keep your hands at 90 degree angle like the photo (you can also adjust the length based on your personal skipping habits)

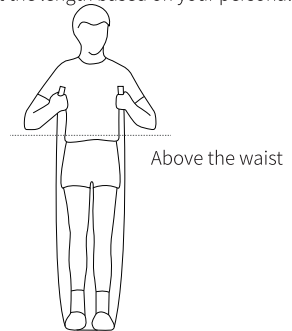

## Correct skipping posture

Please stand naturally with your ankles slightly apart ,put your upper arms close to your body and your forearms extended to your sides ,use your wrist swing the handle and bent your legs , then start to jump (Do not land your heel and sole of the foot at the same time when skipping !)

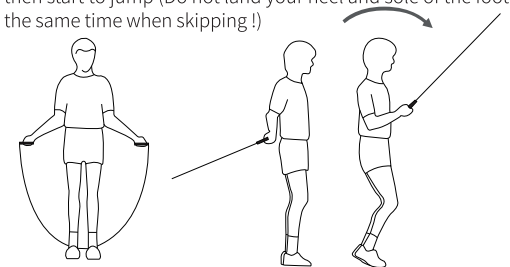

## Start to use Smart Skip

Please scan the QR code below to download and install the Smart Skip APP JCSkip (notes: please don' t install the JCSkip APP via some other link , it may cause can' t use and connect to your device ! )

Make sure your smart phone has the features below :

- iOS version, make sure your apple device is running iOS 10 or above.
- Android version, make sure your Android device has BT4.0 or above and running Android 5.1 or above.



Scan the QR code  
download and install the App“JCSkip”

## How to connect Smart Skip with your Phone

- ① Keep your phone' s BT on and make sure the Smart Skip is power on.
- ② Open JCSkip APP , go to Home screen and press the device icon on up-right coner , the APP will start searching the Smart Skip.
- ③ Press the device you scanned on the list , then APP will connect the Smart Skip automatically.
- ④ Device will show BT icon after connected with phone. After Syncing the data, you can check Daily/Weekly/Montly data on APP and start the group challenge with your friends.

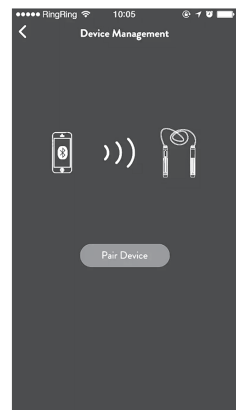

## How to use the Button on Smart Skip

1. Power on the device by long press the button around 2 seconds ,device will enter free skipping mode.
2. Device will enter hibernation mode if not use after 2 minutes (your can wake up the device by single press the button )
3. Long press the button to change the skipping mode (Free skipping mode , Skips count down mode , Time count down mode )
4. You can check current skips and duration , the whole day' s skips and time, system time by single press the button under free skipping mode.
5. Skips count down mode, you can set the count down skips from 100 to 2000 by single press the button, when target finished the Smart Skip will vibrate 3 times and ring to remind.
6. Time count down mode, you can set the count down time from 1 minute to 10 minutes by single press the button,when target finished the Smart Skip will vibrate 3 times and ring to remind.
7. The Smart Skip will power off automatically if you are not using for 5 minutes , you can also long press the button 10 second to power off.

## Notes !

1. Please wear soft sneaker when skipping to protect your heel and leg.
2. Please do some warm-up exercise before skipping , it will help you increasing body blood circulation and avoid damage you joints ,ligaments and muscles.
3. Please do some leg stretching after skipping , it will help you relieve your muscle' s tension and soreness.
4. Please do skipping in right places like lawn, rubber playground or gym , rough ground will increase the resistance during skipping and damage the rope faster.
5. Please skipping in some open area to avoid hurting other people.

## Product information

Product Name : Smart Skip  
Model Number:2023  
APP support: Android 5.1 above iOS 9.0 above  
Product size: 174.8\*25.6 \*25.6mm  
Product weight :121g  
Material: PC+ABS , PVC+ Steel  
Packing include: Handle \*2 User Manual\*1 3 meters PVC & steel wire\*1 Wire loop\*4 Wire cover \*2

## FCC Statement

Changes or modifications not expressly approved by the party responsible for compliance could void the user's authority to operate the equipment. This equipment has been tested and found to comply with the limits for a Class B digital device, pursuant to Part 15 of the FCC Rules. These limits are designed to provide reasonable protection against harmful interference in a residential installation. This equipment generates uses and can radiate radio frequency energy and, if not installed and used in accordance with the instructions, may cause harmful interference to radio communications. However, there is no guarantee that interference will not occur in a particular installation. If this equipment does cause harmful interference to radio or television reception, which can be determined by turning the equipment off and on, the user is encouraged to try to correct the interference by one or more of the following measures:

- Reorient or relocate the receiving antenna.
- Increase the separation between the equipment and receiver.
- Connect the equipment into an outlet on a circuit different from that to which the receiver is connected.
- Consult the dealer or an experienced radio/TV technician for help.

This device complies with part 15 of the FCC rules. Operation is subject to the following two conditions:  
(1) this device may not cause harmful interference, and  
(2) this device must accept any interference received, including interference that may cause undesired operation.