

RF Emission
HAC
TEST REPORT

ISSUED BY
Shenzhen BALUN Technology Co., Ltd.



FOR
CDMA 1x Advanced Feature Phone

ISSUED TO
HOPERUN MMAX DIGITAL PTE. LTD

152 BEACH ROAD #13-06 GATEWAY EAST SINGAPORE 189721



Prepared by: 
Peng Shimeng
(Reporting Specialist)
Date: 2014.6.24
Approved by: 
Wei Yanjun
(Chief Engineer)
Date: 2014.6.24

Report No: BL-SZ14400004-701
EUT Type: CDMA 1x Advanced Feature Phone
Model Name: MXC-550
Brand Name: UMX
FCC ID: 2AB5L-MXC550
Test Standard: FCC 47 CFR Part 20.19
ANSI C63.19: 2007
KDB 285076 D01 HAC Guidance v04
M-Rating: E-Field: M4
H-Field: M4
Test conclusion: PASS
Test Date: May 20, 2014
Date of Issue: Jun 24, 2014

NOTE: This test report can be duplicated completely for the legal use with the approval of the applicant; it shall not be reproduced except in full, without the written approval of Shenzhen BALUN Technology Co., Ltd. BALUN Laboratory. Any objections should be raised within thirty days from the date of issue. To validate the report, please visit BALUN website.

Revision History

<u>Version</u>	<u>Issue Date</u>	<u>Revisions</u>
<u>Rev. 01</u>	<u>May 29, 2014</u>	<u>Initial Issue</u>
<u>Rev .02</u>	<u>Jun 24, 2014</u>	<u>Second edition</u>

TABLE OF CONTENTS

1 GENERAL INFORMATION 4

1.1 Identification of the Testing Laboratory 4

1.2 Identification of the Responsible Testing Location 4

1.3 Test Environment Condition 4

1.4 Announce 4

2 PRODUCT INFORMATION 6

2.1 Applicant 6

2.2 Manufacturer 6

2.3 General Description for Equipment under Test (EUT) 6

2.4 Technical Information 6

2.5 EUT Air Interface description 7

2.6 Ancillary Equipment 7

3 SUMMARY OF TEST RESULTS 8

3.1 Test Standards 8

3.2 HAC Test Configuration and Setting 8

3.3 Summary Of HAC M-Rating 8

3.4 ANSI C63.19 HAC RF Categories 9

3.5 HAC Test Uncertainty 10

4 SATIMO HSC MEASUREMENT SYSTEM 11

4.1 Definition of Hearing Aid Compatibility (HAC) 11

4.2 SATIMO HAC System 11

5 SYSTEM VERIFICATION 17

5.1 System Check Procedure 17

5.2 Validation Procedure 17

5.3 System Validation Setup 18

5.4 System Validation Results 18

6 Probe Modulation Factor (PMF) 19

6.1	PMF Summary	20
7	HAC RF IMMUNITY MEASUREMENT PROCEDURES	21
7.1	HAC Measurement Process Diagram	21
7.2	HAC RF Test Setup	22
7.3	RF Emission Measurement Procedure	22
8	CONDUCTED RF OUPUT POWER.....	23
9	11 HAC RF Emission Test Results.....	24
9.1	E-Filled Emission Test Results	24
9.2	H-Filled Emission Test Results	24
10	TEST EQUIPMENTS LIST	25
11	REFERENCES	26
ANNEX A	HAC TEST RESULT OF SYSTEM VERIFICAION.....	27
ANNEX B	HAC TEST SETUP PHOTOS	31
ANNEX C	HAC RF MEASUREMENT RESULT.....	32
ANNEX D	CALIBRATION FOR PROBE AND DIPOLE	51

1 GENERAL INFORMATION

1.1 Identification of the Testing Laboratory

Company Name	Shenzhen BALUN Technology Co., Ltd.
Address	Block B, 1st FL, Baisha Science and Technology Park, Shahe Xi Road, Nanshan District, Shenzhen, Guangdong Province, P. R. China
Phone Number	+86 755 6683 3402
Fax Number	+86 755 6182 4271

1.2 Identification of the Responsible Testing Location

Test Location	Shenzhen BALUN Technology Co., Ltd.
Address	Block B, 1st FL, Baisha Science and Technology Park, Shahe Xi Road, Nanshan District, Shenzhen, Guangdong Province, P. R. China
Accreditation Certificate	<p>The laboratory has been listed by Industry Canada to perform electromagnetic emission measurements. The recognition numbers of test site are 11524A-1.</p> <p>The laboratory has been listed by US Federal Communications Commission to perform electromagnetic emission measurements. The recognition numbers of test site are 832625.</p> <p>The laboratory has met the requirements of the IAS Accreditation Criteria for Testing Laboratories (AC89), has demonstrated compliance with ISO/IEC Standard 17025:2005. The accreditation certificate number is TL-588.</p> <p>The laboratory is a testing organization accredited by China National Accreditation Service for Conformity Assessment (CNAS) according to ISO/IEC 17025. The accreditation certificate number is L6791.</p>
Description	All measurement facilities used to collect the measurement data are located at Block B, FL 1, Baisha Science and Technology Park, Shahe Xi Road, Nanshan District, Shenzhen, Guangdong Province, P. R. China 518055

1.3 Test Environment Condition

Ambient Temperature	20 to 22 °C
Ambient Relative Humidity	30 to 60 %
Ambient Pressure	86 to 106 kPa

1.4 Announce

- (1) The test report is invalid if not marked with the signatures of the persons responsible for preparing and approving the test report.
- (2) The test report is invalid if there is any evidence and/or falsification.
- (3) The results documented in this report apply only to the tested sample, under the conditions and modes of

operation as described herein.

- (4) This document may not be altered or revised in any way unless done so by BALUN and all revisions are duly noted in the revisions section.
- (5) Content of the test report, in part or in full, cannot be used for publicity and/or promotional purposes without prior written approval from the laboratory.

2 PRODUCT INFORMATION

2.1 Applicant

Applicant	HOPERUN MMAX DIGITAL PTE. LTD
Address	152 BEACH ROAD #13-06 GATEWAY EAST SINGAPORE 189721

2.2 Manufacturer

Manufacturer	HOPERUN MMAX DIGITAL PTE. LTD
Address	152 BEACH ROAD #13-06 GATEWAY EAST SINGAPORE 189721

2.3 General Description for Equipment under Test (EUT)

EUT Type	CDMA 1x Advanced Feature Phone
Model Under the test	MXC-550
Series Model Name	N/A
Difference description	N/A
Hardware Version	N/A
Software Version	N/A
Dimensions	109×48×16 mm
Weight	120 g
Network and Wireless connectivity	CDMA BC0/BC10/BC1 Bluetooth,
Display	TFT-LCD,
Chipset	N/A

2.4 Technical Information

The requirement for the following technical information of the EUT was tested in this report:

Operating Mode	CDMA: CDMA Voice; Bluetooth: V2.1+EDR
Frequency Range	CDMA BC0 (US Cellular): 824.70MHz ~ 848.31 MHz; CDMA BC10 (US Secondary 800): 817.90MHz ~ 823.10 MHz; CDMA BC1 (US PCS): 1851.25MHz ~ 1908.75 MHz; Bluetooth: 2402MHz ~ 2480MHz
Antenna Type	WWAN: PIFA Antenna Bluetooth: PIFA Antenna
DTM	Not Support
Hotspot Function	Not Support
Environment	Uncontrolled
EUT Stage	Portable Device

2.5 EUT Air Interface description

Air Interface	Band	Type	C63.19 Tested	Simultaneous Transmitter	OTT	Power Reduction
CDMA	BC0	Voice	Yes	Bluetooth	NA	Not Support
	BC10	Voice	Yes	Bluetooth	NA	Not Support
	BC1	Voice	Yes	Bluetooth	NA	Not Support
Bluetooth	2450	Data	No	CDMA	NA	Not Support

2.6 Ancillary Equipment

Ancillary Equipment 1	Battery	
	Brand Name	N/A
	Model No	AB043446LA
	Serial No	N/A
	Capacitance	800mAh
	Rated Voltage	3.7V
	Extreme Voltage	Low: 3.4V / High:4.2V
Ancillary Equipment 2	AC Adapter (Charger for Battery)	
	Brand Name	N/A
	Model No	N/A
	Serial No	(n.a. marked #1 by test site)
	Rated Input	~ 100-240V, 50/60Hz
	Rated Output	≡ 5V, 600mA
Ancillary Equipment 3	Stereo Headset	
Ancillary Equipment 4	USB Data Cable	

3 SUMMARY OF TEST RESULTS

3.1 Test Standards

No.	Identity	Document Title
1	FCC 47 CFR Part 20.19	Hearing aid-compatible mobile handsets.
2	ANSI C 63.19:2007	American National Standard Methods of Measurement of Compatibility between Wireless Communications Devices and Hearing Aids
3	KDB 285076 D01 HAC Guidance v04	Provides equipment authorization guidance for mobile handsets subject to the requirements of Section 20.19 for hearing aid compatibility

3.2 HAC Test Configuration and Setting

For HAC RF emission testing, the EUT was linked and controlled by wireless communication test set. Communication between the EUT and the wireless communication test set was established by air link. The distance between the EUT and the communicating antenna of the test set is larger than 50 cm and the output power radiated from the wireless communication test set antenna is at least 30 dB smaller than the output power of EUT. The EUT was set from the wireless communication test set to radiate maximum output power during HAC testing.

3.3 Summary Of HAC M-Rating

Band	Measurement Result		M-Rating
	Field Type	Value	
CDMA BC0 (Voice)	E-Field (V/m)	108.34	M4
	H-Field (A/m)	0.27	M4
CDMA BC10 (Voice)	E-Field (V/m)	157.53	M4
	H-Field (A/m)	0.32	M4
CDMA BC1 (Voice)	E-Field (V/m)	37.55	M4
	H-Field (A/m)	0.10	M4

3.4 ANSI C63.19 HAC RF Categories

3.4.1 RF Emissions

The ANSI Standard presents performance requirements for acceptable interoperability of hearing with wireless communications devices. When these parameters are met, a hearing aid operates acceptably in close proximity to a wireless communications device.

<960MHz Limit:

Category	AWF (dB)	Limits for E-Field Emission (V/m)	Limits for H-Field Emission (A/m)
M1	0	631.0 - 1122.0	1.91 - 3.39
	-5	473.2 - 841.4	1.43 - 2.54
M2	0	354.8 - 631.0	1.07 - 1.91
	-5	266.1 - 473.2	0.80 - 1.43
M3	0	199.5 - 354.8	0.6 - 1.07
	-5	149.6 - 266.1	0.45 - 0.80
M4	0	<199.5	<0.60
	-5	<149.6	<0.45

Hearing aid and WD near-field categories as defined in ANSI PC 63.19. During testing, the hearing aid must maintain an input-referenced interference level of less than 55dB a gain compression of less than 6dB.

>960MHz Limit:

Category	AWF (dB)	Limits for E-Field Emission (V/m)	Limits for H-Field Emission (A/m)
M1	0	199.5 - 354.8	0.6 - 1.07
	-5	149.6 - 266.1	0.45 - 0.8
M2	0	112.2 - 199.5	0.34 - 0.6
	-5	84.1 - 149.6	0.25 - 0.45
M3	0	63.1 - 112.2	0.19 - 0.34
	-5	47.3 - 84.1	0.15 - 0.25
M4	0	<63.1	<0.19
	-5	<47.3	<0.15

3.4.2 Articulation Weighing Factor (AWF)

Standard	Technology	AWF
T1/T1P1/3GPP	UMTS(WCDMA)	0
IS-95	CDMA	0
iden	GSM(22and 11Hz)	0
J-STD-007	GSM(217Hz)	-5

AWF has been developed from information presented to the committee regarding the interference potential of the various modulation types according to ANSI PC 63.19

3.5 HAC Test Uncertainty

The following measurement uncertainty levels have been estimated for tests performed on the EUT as specified in ANSI C 63.19:2007. This uncertainty represents an expanded uncertainty expressed at approximately the 95% confidence level using a coverage factor of $k=2$.

Uncertainty Component	Uncertainty Value	Prob. Dist.	Div.	Ci (E)	Ci (H)	Std. Unc. (+/- %)	
						E	H
Measurement System							
Probe calibration	6.00	N	1.000	1	1	6.00	6.00
Axial Isotropy	2.02	R	1.732		1	1.17	1.17
Sensor Displacement	14.30	R	1.732	1	0.217	8.26	1.79
Boundary effect	2.50	R	1.732	1	1	0.87	0.87
Phantom Boundary Effect	6.89	R	1.732	1	0	3.52	0.00
Linearity	2.58	R	1.732	1	1	1.49	1.49
Scaling to PMR Calibration	9.02	N	1.000	1	1	9.02	9.02
System detection limits	1.30	R	1.732	1	1	0.75	0.75
Readout Electronics	0.25	R	1.732	1	1	0.14	0.14
Response Time	1.23	R	1.732	1	1	0.71	0.71
Integration Time	2.15	R	1.732	1	1	1.24	1.24
RF ambient Conditions	2.03	R	1.732	1	1	1.17	1.17
RF Reflections	9.09	R	1.732	1	1	5.25	5.25
Probe positioner	0.63	N	1.000	1	0.71	0.63	0.45
Probe positioning	3.12	N	1.000	1	0.71	3.12	2.22
Extrapolation and Interpolation	1.18	R	1.732	1	1	0.68	0.68
Test sample Related							
Test sample positioning Vertical	2.73	R	1.732	1	0.71	1.58	1.12
Test sample positioning Lateral	1.19	R	1.732	1	1	0.69	0.69
Device holder and Phantom	2.20	N	1.000	1	1	2.20	2.20
Power drift	4.08	R	1.732	1	1	2.36	2.36
Phantom and Setup Related							
Phantom Thickness	2.00	N	1.000	1	0.6	2.00	1.20
Combined Std. Uncertainty($k=1$)						16.18	13.25
Expanded Uncertainty on Power						32.35	26.50
Expanded Uncertainty on Field						16.18	13.25

4 SATIMO HSC MEASUREMENT SYSTEM

4.1 Definition of Hearing Aid Compatibility (HAC)

On July 10, 2003, the Federal Communications Commission (FCC) adopted new rules requiring wireless manufacturers and service providers to provide digital wireless phones that are compatible with hearing aids. The FCC has modified the exemption for wireless phones under the Hearing Aid Compatibility Act of 1998 (HAC Act) in WT Docket 01-309 RM-8658 to extend the benefits of wireless telecommunications to individuals with hearing disabilities. These benefits encompass business, social and emergency communications, which increase the value of the wireless network for everyone. An estimated more than 10% of the population in the United States show signs of hearing impairment and of that fraction, almost 80% use hearing aids. Approximately 500 million people worldwide suffer from hearing loss.

Compatibility Tests involved:

The standard calls for wireless communications devices to be measured for:

- RF Electric-field emissions.
- RF Magnetic- field emissions.
- T-coil mode, magnetic-signal strength in the audio band.
- T-coil mode, magnetic-signal frequency response through the audio band.
- T-coil mode, magnetic-signal and noise articulation index.

The hearing aid must be measured for:

- RF immunity in microphone mode
- RF immunity in T-coil mode

4.2 SATIMO HAC System

SATIMO HAC System Diagram:

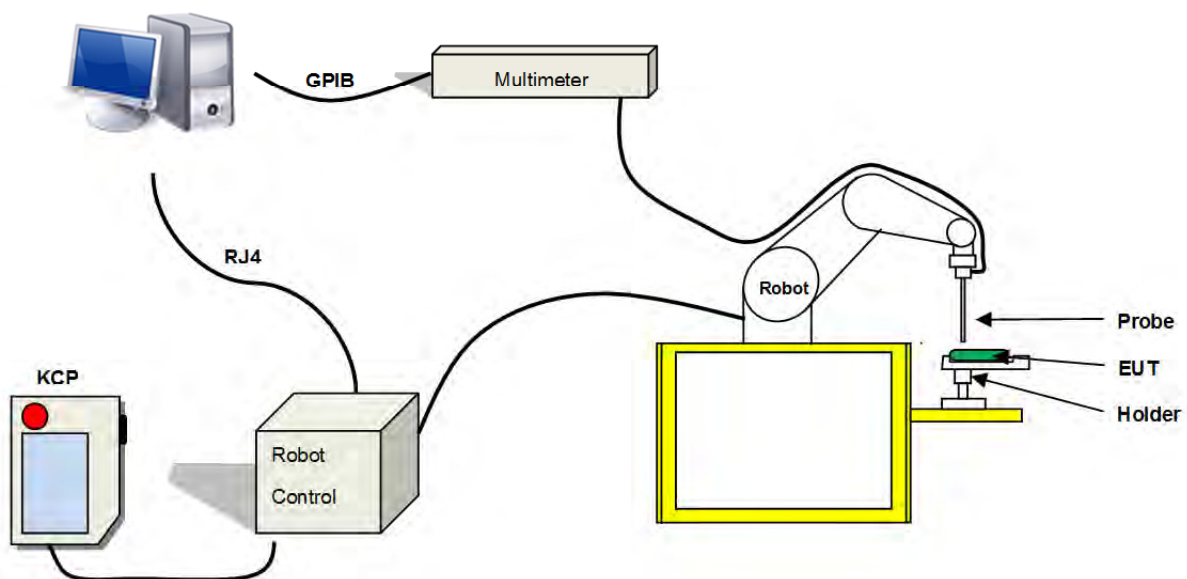

4.2.1 Robot

The SATIMO HAC system uses the high precision robots from KUKA. For the 6-axis controller system, the robot controller version (KUKA) from KUKA is used. The KUKA robot series have many features that are important for our application:



- High precision (repeatability ± 0.035 mm)
- High reliability (industrial design)
- Jerk-free straight movements
- Low ELF interference (the closed metallic construction shields against motor control fields)

4.2.2 HAC E-Field Probe



Serial Number:	SN 24/13 EPH41
Frequency:	0.7GHz – 2.5GHz
Probe length:	330mm
Length of one dipole:	3.3mm
Maximum external diameter:	8mm
Probe extremity diameter:	5mm
Distance between dipoles/probe extremity:	3mm
Resistance of the three dipole (at the connector):	Dipole 1:R1=2.1807 M Ω Dipole 2:R1=2.0612 M Ω Dipole 3:R3=2.1892 M Ω
Connector (HIROSE series SR30)	6 wire male (Hirose SR30series)

E-Field Probe Calibration Process

All methods used to perform the measurements and calibrations comply with the ANSI C63.19 and IEEE 1309 standards.

LINEARITY

The linearity was determined using a standard dipole with the probe positioned 10 mm above the dipole. The input power of the dipole was adjusted from -15 to 36 dBm using a 1dB step (to cover the range 2V/m to 1000V/m).

Linearity: +/- 1.49% (+/- 0.07 dB)

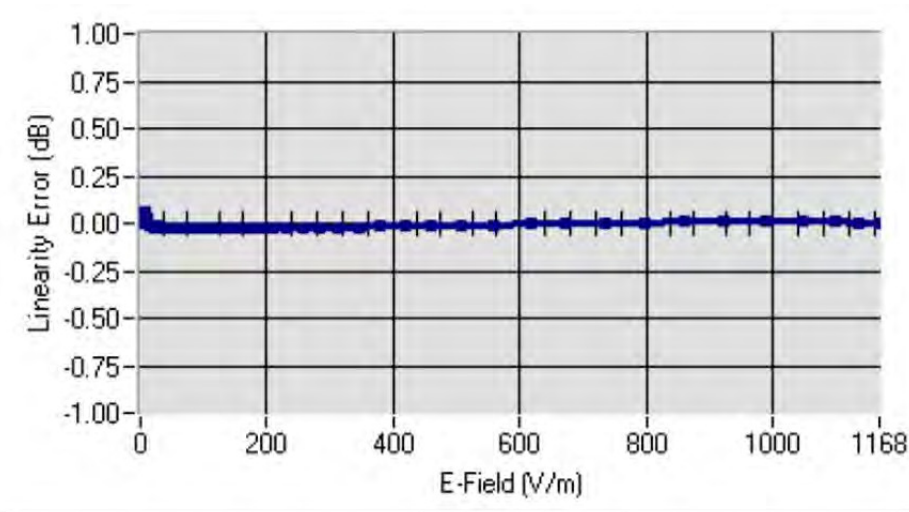

SENSITIVITY

The sensitivity factors of the three dipoles were determined using the waveguide method outlined in the fore mentioned standards.

Calibration curves

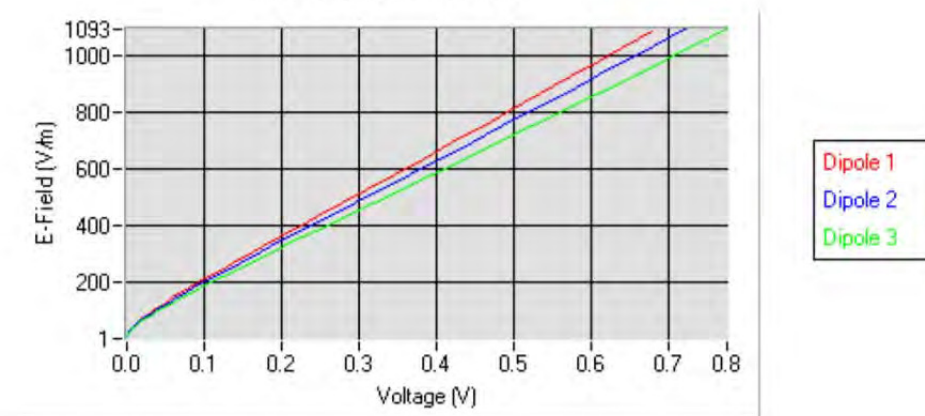

Frequency (GHz)	Normz dipole 1 ($\mu\text{V}/(\text{V}/\text{m})^2$)	Normz dipole 2 ($\mu\text{V}/(\text{V}/\text{m})^2$)	Normz dipole 3 ($\mu\text{V}/(\text{V}/\text{m})^2$)
0.7GHz-2.5GHz	6.54	4.86	5.80
Frequency (GHz)	DCP dipole 1 (mV)	DCP dipole 2 (mV)	DCP dipole 3 (mV)
0.7GHz-2.5GHz	96	96	92

ISOTROPY

The axial isotropy was evaluated by exposing the probe to a reference wave from a standard dipole. The probe was rotated along its main axis from 0 - 360 degrees in 15 degree steps.

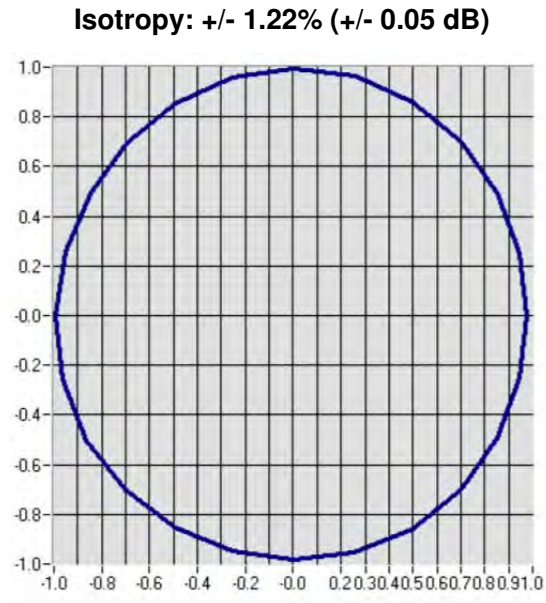

4.2.3 HAC H-Field Probe



Serial Number:	SN 24/13 EPH49
Frequency:	0.7GHz – 2.5GHz
Probe length:	330mm
Length of one dipole:	3.3mm
Maximum external diameter:	8mm
Probe extremity diameter:	5mm
Distance between dipoles/probe extremity:	3mm
Resistance of the three dipole (at the connector):	Dipole 1:R1=0.289 MΩ Dipole 2:R1=0.287 MΩ Dipole 3:R3=0.281 MΩ
Connector (HIROSE series SR30)	6 wire male (Hirose SR30series)

Calibration Method Procedure

All methods used to perform the measurements and calibrations comply with the ANSI C63.19 and IEEE 1309 standards.

LINEARITY

The linearity was determined using a standard dipole with the probe positioned 10 mm above the dipole. The input power of the dipole was adjusted from -15 to 36 dBm using a 1dB step (to cover the range 0.01A/m to 2A/m).

Linearity: +/- 1.83% (+/- 0.08 dB)

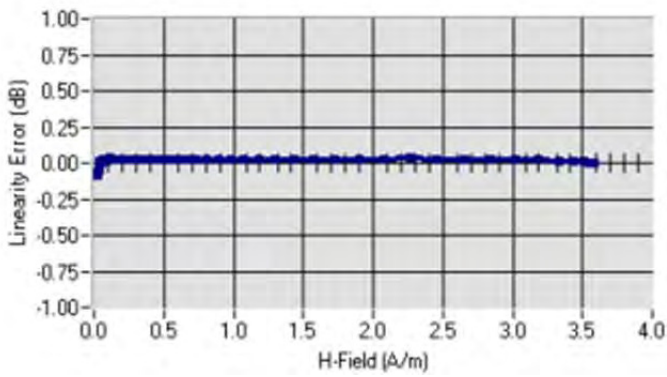

Linearity @ 835MHz

Linearity: +/- 1.36% (+/- 0.06 dB)

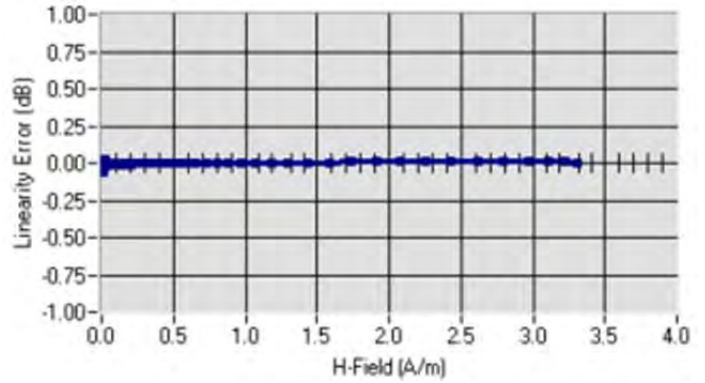

Linearity @ 1900MHz

SENSITIVITY

The sensitivity factors of the three dipoles were determined using the waveguide method outlined in the fore mentioned standards.

Frequency (GHz)	Normz loop 1 ($\mu\text{V}/(\text{A}/\text{m})^2$)	Normz loop 2 ($\mu\text{V}/(\text{A}/\text{m})^2$)	Normz loop 3 ($\mu\text{V}/(\text{A}/\text{m})^2$)
0.7GHz-1.0GHz	0.062	0.072	0.068
1.7GHz-2.5GHz	0.35	0.41	0.37
Frequency (GHz)	DCP dipole 1 (mV)	DCP dipole 2 (mV)	DCP dipole 3 (mV)
0.7GHz-2.5GHz	112	102	106

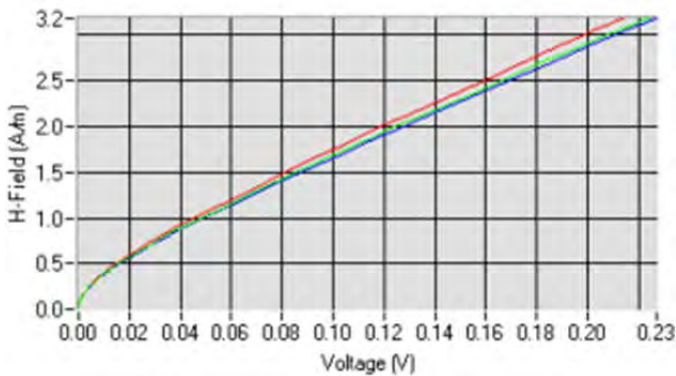

Calibration Curves @ 835MHz

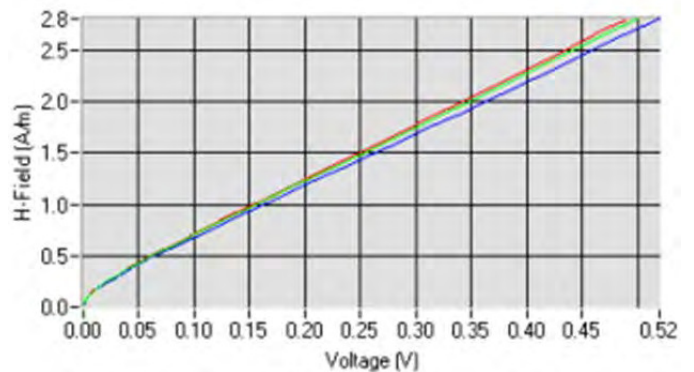

Calibration Curves @ 1900MHz

ISOTROPY

The axial isotropy was evaluated by exposing the probe to a reference wave from a standard dipole. The probe was rotated along its main axis from 0 - 360 degrees in 15 degree steps.

Isotropy: +/- 1.22% (+/- 0.05 dB)

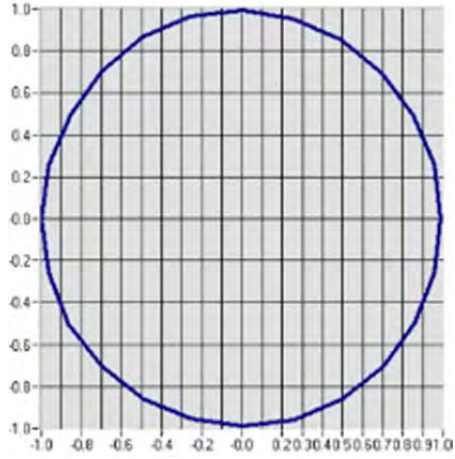

Isotropy @ 835MHz

Isotropy: +/- 1.22% (+/- 0.05 dB)

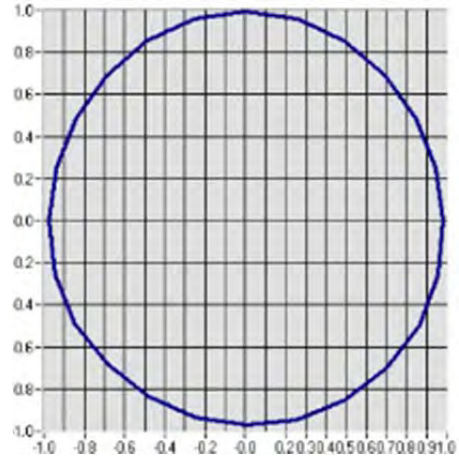

Isotropy @ 1900MHz

5 SYSTEM VERIFICATION

5.1 System Check Procedure

The input signal was an unmodulated continuous wave. The following points were taken into consideration in performing this check:

- Average Input Power $P = 100\text{mW RMS}$ (20dBm RMS) after adjustment for return loss
- The test fixture must meet the 2 wavelength separation criterion
- The proper measurement of the 1 cm probe to dipole separation, which is measured from top surface of the dipole to the calibration reference point of the sensor, defined by the probe manufacturer is shown in the following diagram:

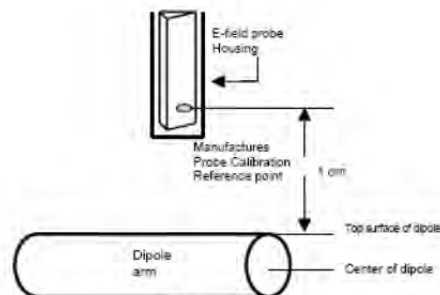

Figure 15
Separation Distance from Dipole to Field Probe

RF power was recorded using both an average reading meter and a peak reading meter. Readings of the probe are provided by the measurement system. To assure proper operation of the near-field measurement probe the input power to the dipole shall be commensurate with the full rated output power of the wireless device (e.g. - for a cellular phone wireless device the average peak antenna input power will be on the order of 100mW (i.e. - 20dBm) RMS after adjustment for any mismatch.

5.2 Validation Procedure

A dipole antenna meeting the requirements given in PC63.19 was placed in the position normally occupied by the WD. The length of the dipole was scanned with both E-field and H-field probes and the maximum values for each were recorded. Using the near-field measurement system, scan the antenna over the radiating dipole and record the greatest field reading observed. Due to the nature of E-fields about free-space dipoles, the two E-field peaks measured over the dipole are averaged to compensate for non-parallelity of the setup see manufacturer method on dipole calibration certificates, Field strength measurements shall be made only when the probe is stationary. RF power was recorded using both an average and a peak power reading meter.

Setup for Desired Output Power to Dipole

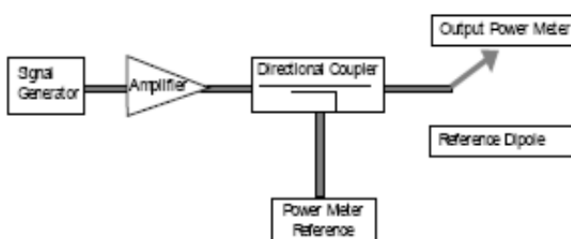

Setup to Dipole

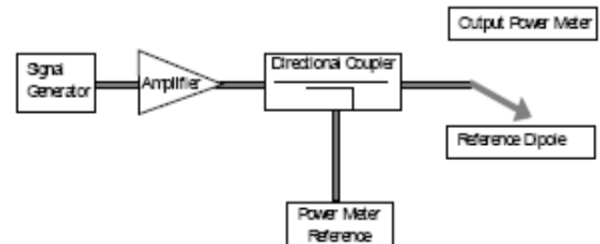

5.3 System Validation Setup

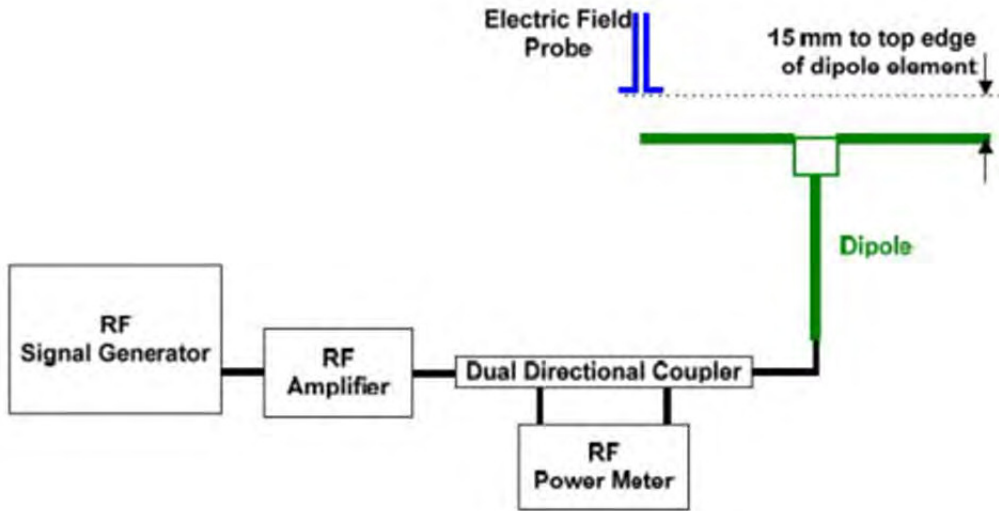

Using this setup configuration, the signal generator was adjusted for the desired output power 20dBm (100mW) at a specified frequency. The reference power from the coupled port of the directional coupler is recorded. Next, the output cable is connected to the reference dipole

5.4 System Validation Results

Comparing to the original HAC value provided by SATIMO, the validation data should be within its specification of 10 %.

Frequency	Input Power (dBm)	E-field Result (V/m)	Target Field (V/m)	Tolerance (%)	Date
835 MHz	20.0	205	220.4	-6.99	2014/05/20
1880MHz	20.0	161.52	153.4	5.29	2014/05/20
Frequency	Input Power (dBm)	H-field Result (A/m)	Target Field (A/m)	Tolerance (%)	Date
835 MHz	20.0	0.448	0.445	-0.67	2014/05/20
1880MHz	20.0	0.447	0.445	0.45	2014/05/20

6 Probe Modulation Factor (PMF)

The HAC standard ANSI C63.19-2011 requires measurement of the peak envelope E-field and H-field of the wireless device. Paragraph 4.2.2.1 and C.3.1 of that standard describes the probe modulation factor that shall be applied to convert the probe reading to peak envelope field. The PMF measurement procedure is as follows.

- a. Install a validation dipole for the appropriate frequency band under the Test Arch Phantom and select the proper phantom section according to the probe type installed (E-field or H-field). Move the probe to the point with the highest field, with very similar field contributions from all channels. Switch the arm power off and do not move the probe between the subsequent CW and modulated measurement.
- b. The modulated signal to the dipole must be monitored to record peak amplitude and compared to a CW signal with the same peak envelope level.
- c. Do not move the setup after the coupler between the modulated and the CW measurement. For modulated signal measurement, connect the modulated signal using the appropriate frequency via the cable to the dipole.
- d. Run the multi-meter in the procedure with the corresponding modulation setting in continuous mode.
- e. Adjust the signal amplitude to achieve the same field level display in the multi-meter as during the WD field scan.
- f. Read the envelope peak on the monitor in order to adjust the CW signal later to the same level.
- g. Switch the signal source off and verify that the ambient and instrumentation noise level is at least 10 dB lower.
- h. For CW measurement, change the signal to CW at the same center frequency, without touching or moving the dipole or probe in the setup.
- i. Adjust the CW signal amplitude to the same peak level on the spectrum analyzer.
- j. Run the multi-meter in the CW procedure in continuous mode.
- k. Read the multi-meter total field display and note it together with the probe ID, modulation type and frequency.
- l. Calculate the PMF as the ratio between the CW multi-meter field reading and the reading for the applicable modulation.

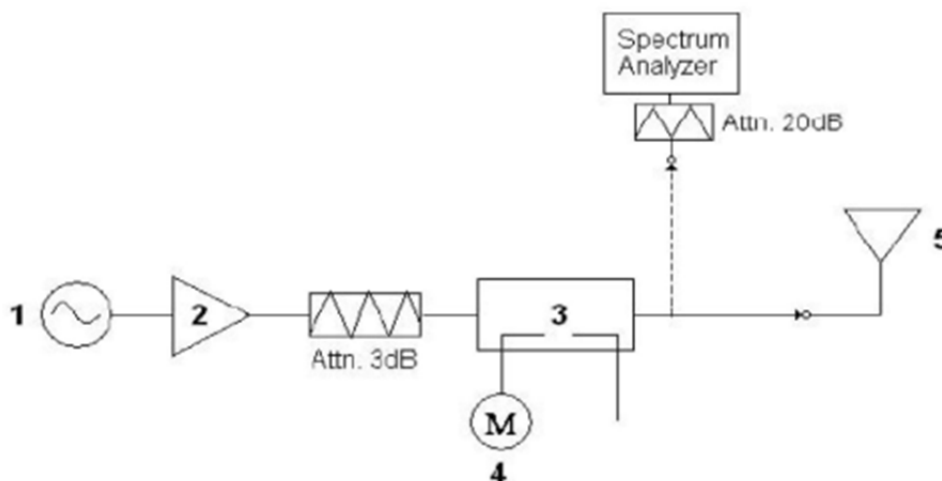

6.1 PMF Summary

Probe	Frequency (MHz)	Signal Type	E-Field (V/m)	PMF
E-Field Probe	835	CDMA	233.64	0.87
		CW	203.27	
	1880	CDMA	178.21	0.89
		CW	158.61	

Probe	Frequency (MHz)	Signal Type	H-Field (A/m)	Tolerance (%)
H-Field Probe	835	CDMA	0.491	0.90
		CW	0.422	
	1880	CDMA	0.518	0.88
		CW	0.456	

7 HAC RF IMMUNITY MEASUREMENT PROCEDURES

7.1 HAC Measurement Process Diagram

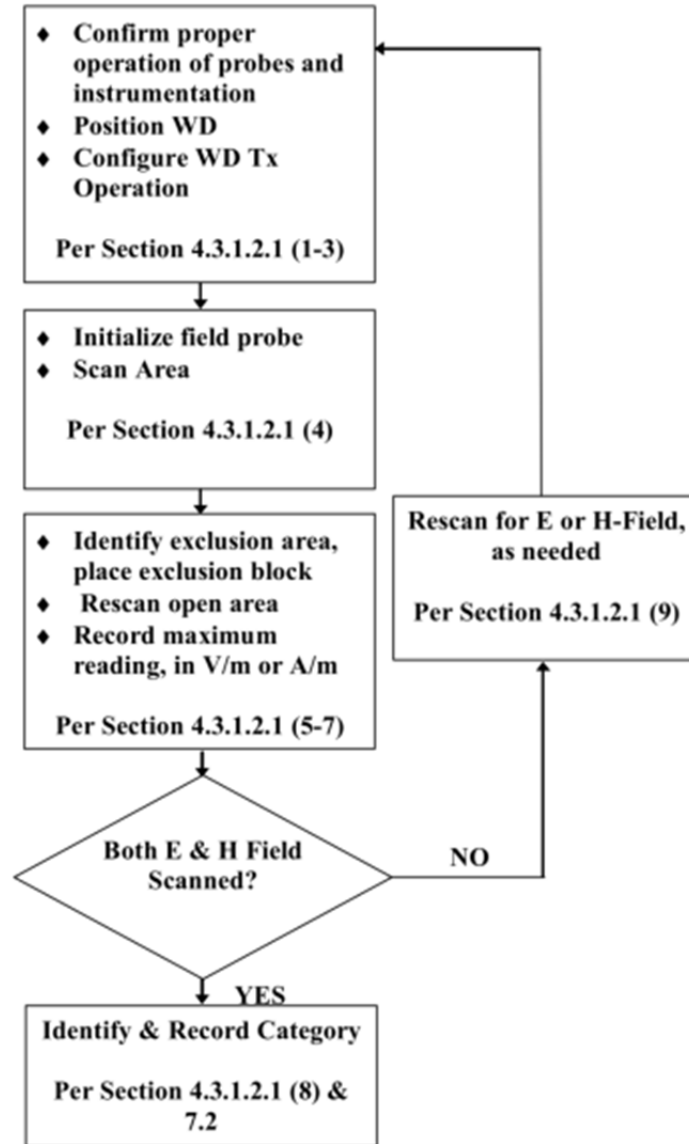

7.2 HAC RF Test Setup



Reference and plane for RF emission measurements

7.3 RF Emission Measurement Procedure

The following illustrate a typical RF emissions test scan over a wireless communications device:

- Proper operation of the field probe, probe measurement system, other instrumentation, and the positioning system was confirmed.
- WD is positioned in its intended test position, acoustic output point of the device perpendicular to the field probe.
- The WD operation for maximum rated RF output power was configured and confirmed with the base station simulator, at the test channel and other normal operating parameters as intended for the test. The battery was ensured to be fully charged before each test.
- The center sub-grid was centered over the center of the acoustic output (also audio band magnetic output, if applicable). The WD audio output was positioned tangent (as physically possible) to the measurement plane.
- A surface calibration was performed before each setup change to ensure repeatable spacing and proper maintenance of the measurement plane using the HAC Phantom.
- The measurement system measured the field strength at the reference location.

8 CONDUCTED RF OUPUT POWER

The CDMA measurement conducted power as following:

BAND		CDMA BC0			CDMA BC10		
Channel		1013	384	777	476	526	684
Frequency (MHz)		824.70	836.52	848.31	817.90	819.10	823.10
RC 1	SO55 (dBm)	29.01	29.15	28.58	28.28	28.55	28.90
RC 3	SO55 (dBm)	29.08	29.15	28.63	28.30	28.57	28.90
	SO32 (dBm)	29.05	29.13	28.60	28.26	28.56	28.86
BAND		CDMA BC1			/		
Channel		25	600	1175	/	/	/
Frequency (MHz)		1851.25	1880.00	1908.75	/	/	/
RC 1	SO55 (dBm)	27.58	28.00	27.46	/	/	/
RC 3	SO55 (dBm)	27.60	28.01	27.49	/	/	/
	SO32 (dBm)	27.55	28.01	27.41	/	/	/

Bluetooth mode:

Mode	GFSK			$\pi/4$ -DQPSK		
Channel	1	39	79	1	39	79
Frequency (MHz)	2402	2441	2480	2402	2441	2480
Peak Power (dBm)	8.653	9.103	9.281	9.422	9.879	10.03
Mode	8-DPSK			BLE		
Channel	1	39	79	1	19	40
Frequency (MHz)	2402	2441	2480	2402	2441	2480
Peak Power (dBm)	9.77	10.20	10.32	/	/	/

9 11 HAC RF Emission Test Results

9.1 E-Filled Emission Test Results

Band	Mode	Ch.	Freq. (MHz)	Peak E-Field (V/m)	M-Rating	Meas. No.
BC 0	Voice	1013	824.70	108.34	M4	1#
		384	836.52	79.82	M4	2#
		777	848.31	80.07	M4	3#
BC 10	Voice	476	817.90	157.53	M4	7#
		526	819.10	129.08	M4	8#
		684	823.10	128.30	M4	9#
BC 1	Voice	25	1851.25	37.55	M4	13#
		600	1880.00	33.29	M4	14#
		1175	1908.75	32.11	M4	15#

9.2 H-Filled Emission Test Results

Band	Mode	Ch.	Freq. (MHz)	Peak H-Field (A/m)	M-Rating	Meas. No.
BC 0	Voice	1013	824.70	0.27	M4	4#
		384	836.52	0.10	M4	5#
		777	848.31	0.08	M4	6#
BC 10	Voice	476	817.90	0.32	M4	10#
		526	819.10	0.28	M4	11#
		684	823.10	0.29	M4	12#
BC 1	Voice	25	1851.25	0.10	M4	16#
		600	1880.00	0.08	M4	17#
		1175	1908.75	0.07	M4	18#

10 TEST EQUIPMENTS LIST

Description	Manufacturer	Model	Serial No.	Cal. Date	Cal. Due
PC	Dell	N/A	N/A	N/A	N/A
800-950MHz Dipole	SATIMO	SIDB835	SN 18/12 DHA41	2013/08/07	2014/08/06
1700-2000MHz Dipole	SATIMO	SIDB1900	SN 18/12 DHB46	2013/08/07	2014/08/06
E-Field Probe	SATIMO	SCE	SN 24/13 EPH41	2013/08/07	2014/08/06
H-Field Probe	SATIMO	SCH	SN 24/13 HPH49	2013/08/07	2014/08/06
Antenna	SATIMO	ANTA3	SN 17/13 ZNTA45	N/A	N/A
MultiMeter	Keithley	MultiMeter 2000	4024022	2014/02/13	2015/02/12
Signal Generator	R&S	SMF100A	1167.0000k02/104260	2014/02/17	2015/02/16
Power Meter	Agilent	5738A	11290	2013/10/22	2014/10/21
Power Sensor	R&S	NRP-Z21	103971	2013/12/12	2014/12/11
Power Amplifier	SATIMO	6552B	22374	2013/08/05	2014/08/04
Wireless Communication Test Set	Agilent	8960-E5515C	MY50260493	2013/09/07	2014/09/06
Wireless Communication Test Set	R&S	CMU 200	123666	2013/09/07	2014/09/06
Network Analyzer	R&S	5071C	EMY46103472	2013/12/12	2014/12/11

11 REFERENCES

- 1 FCC 47 CFR Part 20.19 "Hearing aid-compatible mobile handsets."
- 2 ANSI C 63.19:2007 "American National Standard Methods of Measurement of Compatibility between Wireless Communications Devices and Hearing Aids", 27 May 2011
- 3 KDB 285076 D01 HAC Guidance v04, "provides equipment authorization guidance for mobile handsets subject to the requirements of Section 20.19 for hearing aid compatibility
- 4 KDB 285076 D02, T-Coil testing for CMRS IP v01r01 provides guidance for T-Coil tests for voice-over-IP (e.g. LTE and Wi-Fi) CMRS based Telephone Services.
- 4 SATIMO COMOHAC_V4
- 5 SATIMO OPENHAC_V4

ANNEX A HAC TEST RESULT OF SYSTEM VERIFICAION

E-Field System Check Data(835MHz Head)

Experimental conditions.

Grid size (mm x mm)	50.0, 50.0
Step (mm)	5
Band	835 MHz
Channel	
Signal	CW
Date of measurement	2014-05-20

HAC Measurement Results

Frequency (MHz): 835.000000

Probe Modulation Factor = 1.000000

Maximum value of total field = 205 V/m

E in V/m

SURFACE HAC

E in V/m

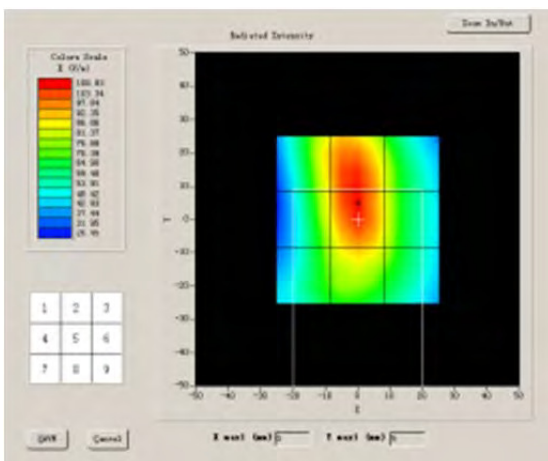

Grid 1: 194.51	Grid 2: 198.12	Grid 3: 177.56
Grid 4: 192.69	Grid 5: 205.00	Grid 6: 178.98
Grid 7: 181.13	Grid 8: 194.18	Grid 9: 176.51

H-Field System Check Data(835MHz Body)

Experimental conditions

Grid size (mm x mm)	50.0, 50.0
Step (mm)	5
Band	835 MHz
Channel	
Signal	CW
Date of measurement	2014-05-20

HAC Measurement Results

Frequency (MHz): 835.000000

Probe Modulation Factor = 1.000000

Maximum value of total field = 0.448 A/m

H in A/m

SURFACE HAC

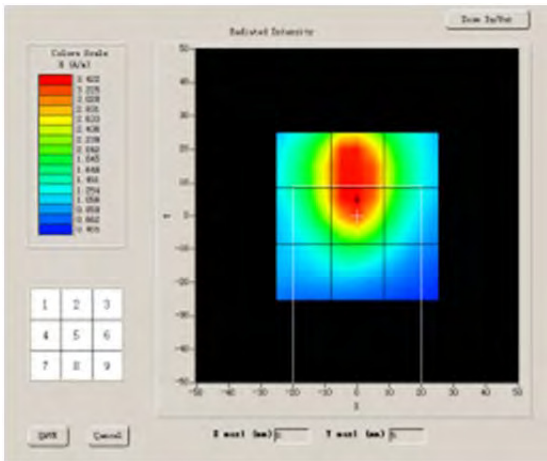

H in A/m

Grid 1: 0.302	Grid 2: 0.421	Grid 3: 0.336
Grid 4: 0.381	Grid 5: 0.449	Grid 6: 0.332
Grid 7: 0.370	Grid 8: 0.400	Grid 9: 0.239

E-Filed System Check Data (1880MHz)

Experimental conditions

Grid size (mm x mm)	50.0, 50.0
Step (mm)	5
Band	1880 MHz
Channel	
Signal	CW
Date of measurement	2014-05-20

HAC Measurement Results

Frequency (MHz): 1880.000000

Probe Modulation Factor = 1.000000

Maximum value of total field = 161.52V/m

SURFACE HAC

E in V/m

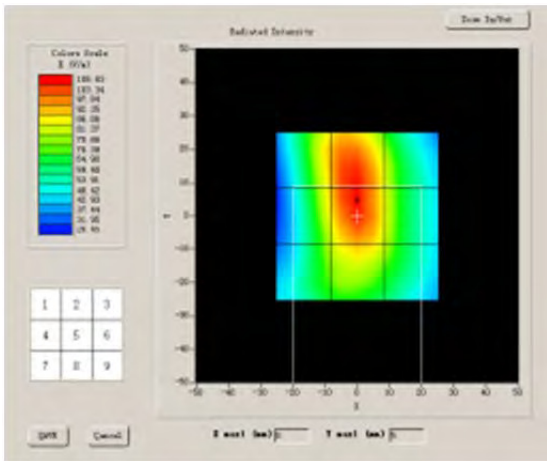

Grid 1: 145.51	Grid 2: 158.33	Grid 3: 136.11
Grid 4: 151.64	Grid 5: 161.52	Grid 6: 142.95
Grid 7: 141.52	Grid 8: 148.62	Grid 9: 126.77

H-Filed System Check Data (1880MHz)

Experimental conditions

Grid size (mm x mm)	50.0, 50.0
Step (mm)	5
Band	1880 MHz
Channel	
Signal	CW
Date of measurement	2014-05-20

HAC Measurement Results

Frequency (MHz): 1880.000000

Probe Modulation Factor = 1.000000

Maximum value of total field = 0.447 A/m

SURFACE HAC

H in A/m

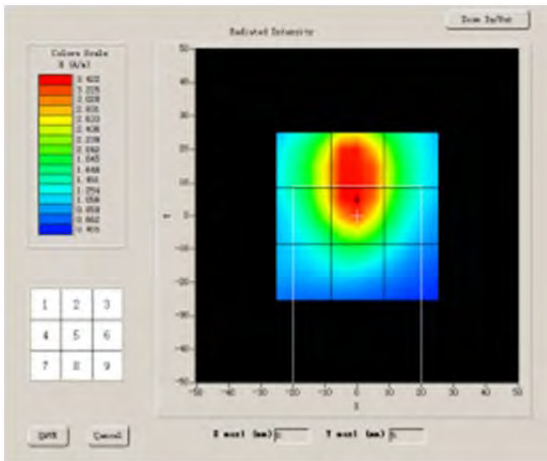

Grid 1: 0.424	Grid 2: 0.434	Grid 3: 0.384
Grid 4: 0.437	Grid 5: 0.447	Grid 6: 0.415
Grid 7: 0.432	Grid 8: 0.415	Grid 9: 0.361

ANNEX B HAC TEST SETUP PHOTOS

E-Filed Measurement Test Setup

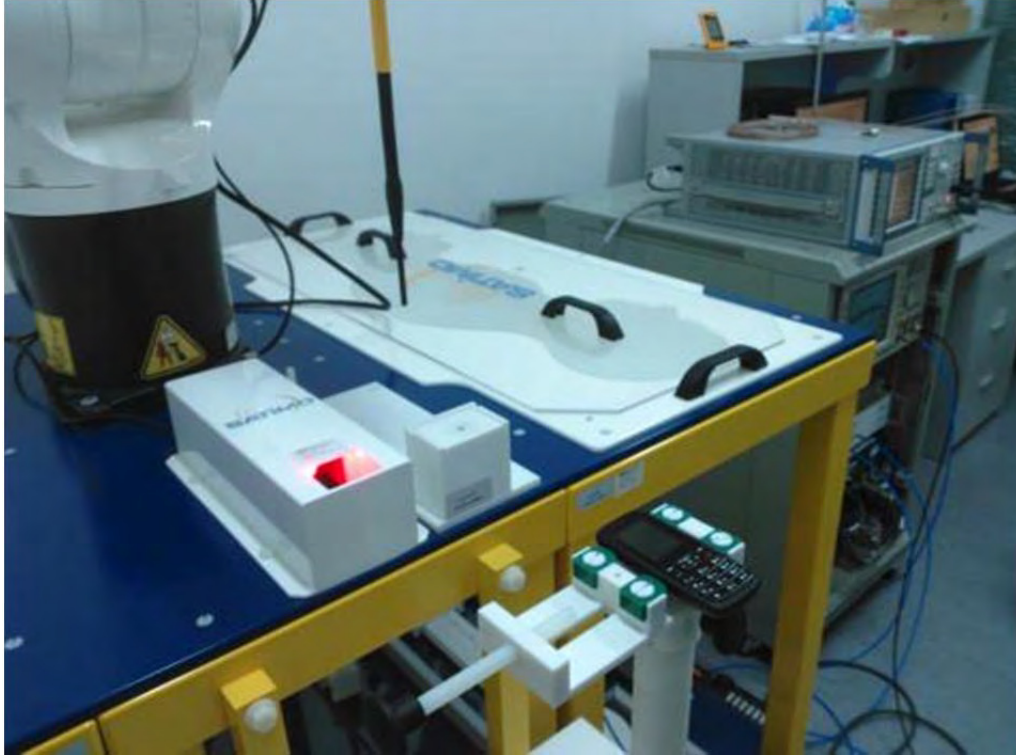

H-Filed Measurement Test Setup

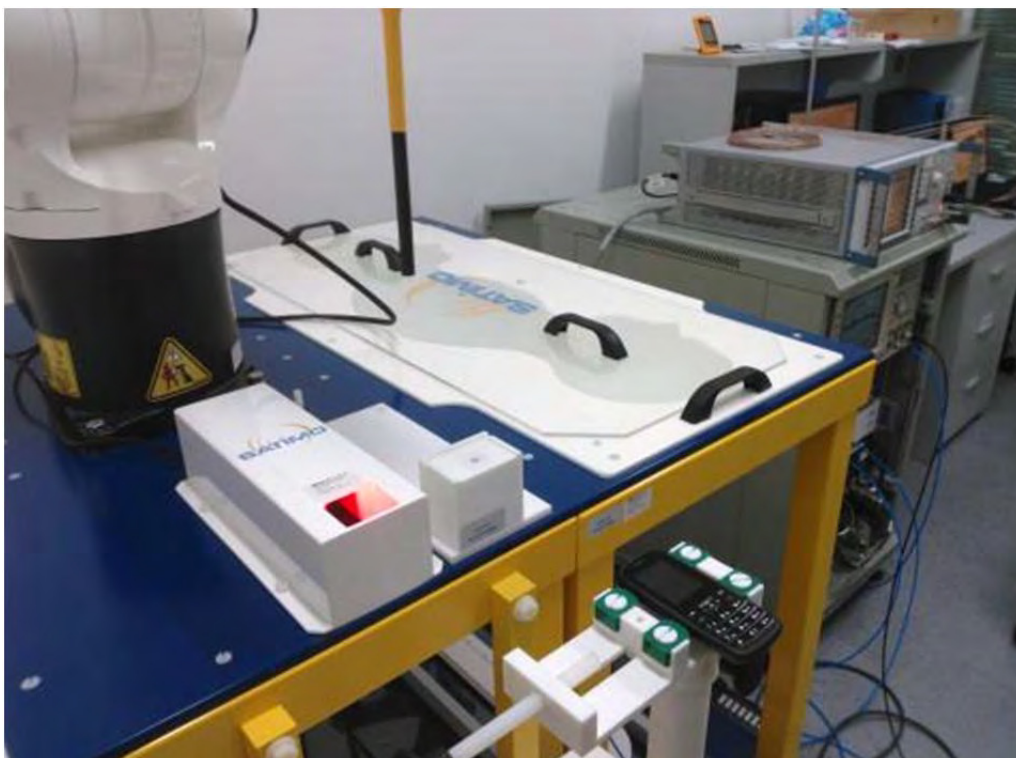

ANNEX C HAC RF MEASUREMENT RESULT

TABLE OF MEASUREMENT RESULT LIST

<u>Band</u>	<u>Mode</u>	<u>PARAMETERS</u>
CDMA BC 0	E-Filed	<u>Measurement 1</u> : E-field on Low Channel
		<u>Measurement 2</u> : E-field on Middle Channel
		<u>Measurement 3</u> : E-field on High Channel
	H-Filed	<u>Measurement 4</u> : H-field on Low Channel
		<u>Measurement 5</u> : H-field on Middle Channel
		<u>Measurement 6</u> : H-field on High Channel
CDMA BC 10	E-Filed	<u>Measurement 7</u> : E-field on Low Channel
		<u>Measurement 8</u> : E-field on Middle Channel
		<u>Measurement 9</u> : E-field on High Channel
	H-Filed	<u>Measurement 10</u> : H-field on Low Channel
		<u>Measurement 11</u> : H-field on Middle Channel
		<u>Measurement 12</u> : H-field on High Channel
CDMA BC 1	E-Filed	<u>Measurement 13</u> : E-field on Low Channel
		<u>Measurement 14</u> : E-field on Middle Channel
		<u>Measurement 15</u> : E-field on High Channel
	H-Filed	<u>Measurement 16</u> : H-field on Low Channel
		<u>Measurement 17</u> : H-field on Middle Channel
		<u>Measurement 18</u> : H-field on High Channel

B

MEASUREMENT 1

Experimental conditions

Grid size (mm x mm)	50.0, 50.0
Step (mm)	5
Band	BC0_US_Cellular
Channel	Low
Signal	CDMA
Date of measurement	2014-05-20

HAC Measurement Results

Lower Band (Channel 1013):

Frequency (MHz): 824.70000

Probe Modulation Factor = 0.870000

Maximum value of total field = 108.34 V/m

Hearing Aid Near-Field Category: M4 (AWF 0 dB)

SURFACE HAC

E in V/m

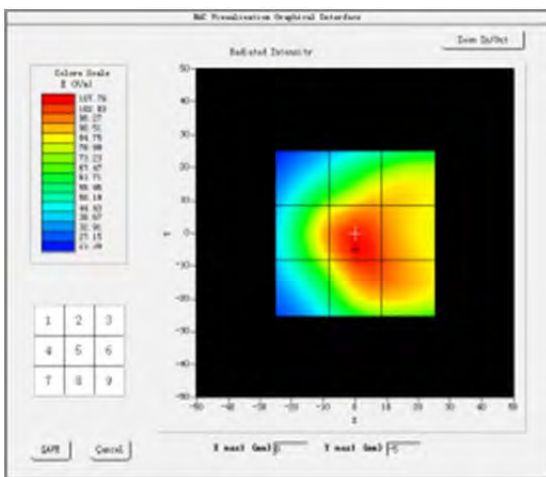

Grid 1: 72.67	Grid 2: 90.64	Grid 3: 89.72
Grid 4: 96.38	Grid 5: 108.34	Grid 6: 98.13
Grid 7: 86.33	Grid 8: 106.31	Grid 9: 99.48

MEASUREMENT 2

Experimental conditions

Grid size (mm x mm)	50.0, 50.0
Step (mm)	5
Band	BC0_US_Cellular
Channel	Middle
Signal	CDMA
Date of measurement	2014-05-20

HAC Measurement Results

Lower Band (Channel 384):

Frequency (MHz): 836.52000

Probe Modulation Factor = 0.870000

Maximum value of total field = 79.82 V/m

Hearing Aid Near-Field Category: M4 (AWF 0 dB)

SURFACE HAC

E in V/m

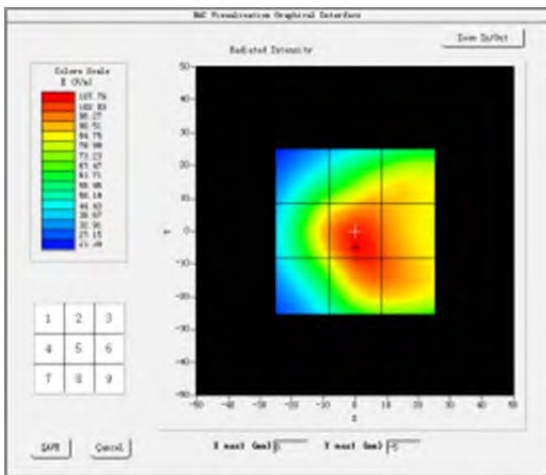

Grid 1: 39.14	Grid 2: 67.10	Grid 3: 66.51
Grid 4: 51.82	Grid 5: 79.82	Grid 6: 71.61
Grid 7: 51.16	Grid 8: 79.34	Grid 9: 72.25

MEASUREMENT 3

Experimental conditions

Grid size (mm x mm)	50.0, 50.0
Step (mm)	5
Band	BC0_US_Cellular
Channel	High
Signal	CDMA
Date of measurement	2014-05-20

HAC Measurement Results

Lower Band (Channel 777):

Frequency (MHz): 848.31000

Probe Modulation Factor = 0.870000

Maximum value of total field = 80.07 V/m

Hearing Aid Near-Field Category: M4 (AWF 0 dB)

SURFACE HAC

E in V/m

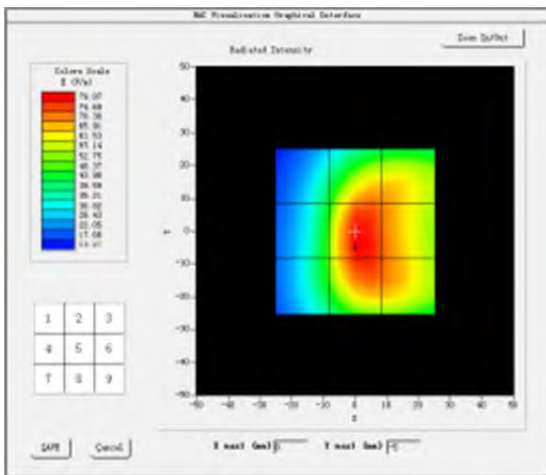

Grid 1: 45.20	Grid 2: 70.15	Grid 3: 67.80
Grid 4: 53.45	Grid 5: 80.07	Grid 6: 70.56
Grid 7: 53.23	Grid 8: 78.73	Grid 9: 70.66

MEASUREMENT 4

Experimental conditions

Grid size (mm x mm)	50.0, 50.0
Step (mm)	5
Band	BC0_US_Cellular
Channel	Low
Signal	CDMA
Date of measurement	2014-05-20

HAC Measurement Results

Lower Band (Channel 1013):

Frequency (MHz): 824.70000

Probe Modulation Factor = 0.900000

Maximum value of total field = 0.27 A/m

Hearing Aid Near-Field Category: M4 (AWF 0 dB)

SURFACE HAC

H in A/m

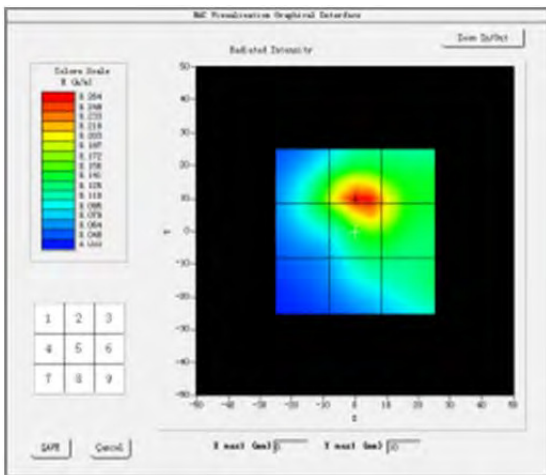

Grid 1: 0.18	Grid 2: 0.27	Grid 3: 0.20
Grid 4: 0.18	Grid 5: 0.27	Grid 6: 0.20
Grid 7: 0.07	Grid 8: 0.13	Grid 9: 0.13

MEASUREMENT 5

Experimental conditions

Grid size (mm x mm)	50.0, 50.0
Step (mm)	5
Band	BC0_US_Cellular
Channel	Middle
Signal	CDMA
Date of measurement	2014-05-20

HAC Measurement Results

Lower Band (Channel 384):

Frequency (MHz): 836.52000

Probe Modulation Factor =0.900000

Maximum value of total field = 0.10 A/m

Hearing Aid Near-Field Category: M4 (AWF 0 dB)

SURFACE HAC

H in A/m

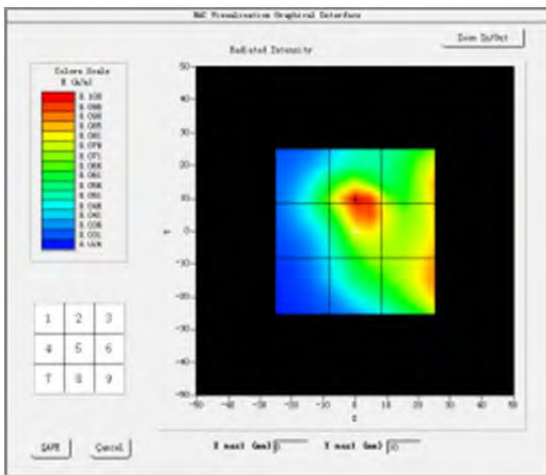

Grid 1: 0.07	Grid 2: 0.10	Grid 3: 0.09
Grid 4: 0.07	Grid 5: 0.10	Grid 6: 0.09
Grid 7: 0.04	Grid 8: 0.07	Grid 9: 0.09

MEASUREMENT 6

Experimental conditions

Grid size (mm x mm)	50.0, 50.0
Step (mm)	5
Band	BC0_US_Cellular
Channel	High
Signal	CDMA
Date of measurement	2014-05-20

HAC Measurement Results

Lower Band (Channel 777):

Frequency (MHz): 848.3100

Probe Modulation Factor =0.900000

Maximum value of total field = 0.08 A/m

Hearing Aid Near-Field Category: M4 (AWF 0 dB)

SURFACE HAC

H in A/m

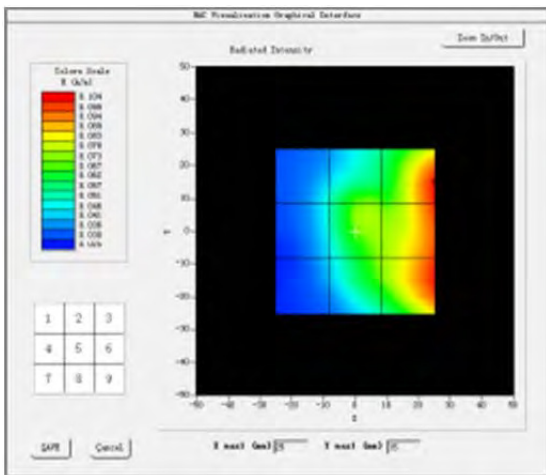

Grid 1: 0.05	Grid 2: 0.07	Grid 3: 0.10
Grid 4: 0.05	Grid 5: 0.08	Grid 6: 0.10
Grid 7: 0.04	Grid 8: 0.07	Grid 9: 0.10

MEASUREMENT 7

Experimental conditions

Grid size (mm x mm)	50.0, 50.0
Step (mm)	5
Band	BC10_Secondary_800MHz
Channel	Low
Signal	CDMA
Date of measurement	2014-05-20

HAC Measurement Results

Lower Band (Channel 476):

Frequency (MHz): 817.90000

Probe Modulation Factor = 0.870000

Maximum value of total field = 157.53 V/m

Hearing Aid Near-Field Category: M4 (AWF 0 dB)

SURFACE HAC

E in V/m

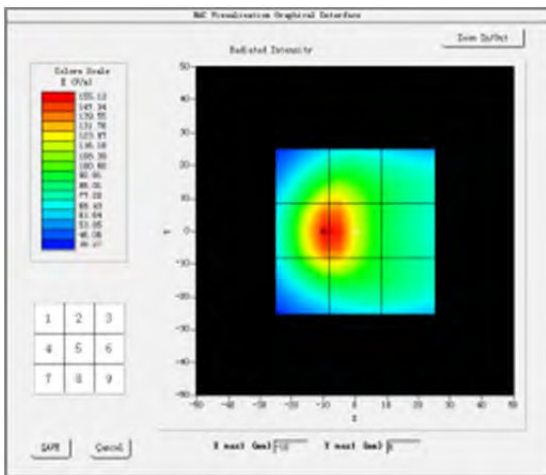

Grid 1: 126.93	Grid 2: 127.68	Grid 3: 90.54
Grid 4: 158.17	Grid 5: 157.53	Grid 6: 90.82
Grid 7: 136.01	Grid 8: 135.81	Grid 9: 89.78

MEASUREMENT 8

Experimental conditions

Grid size (mm x mm)	50.0, 50.0
Step (mm)	5
Band	BC10_Secondary_800MHz
Channel	Middle
Signal	CDMA
Date of measurement	2014-05-20

HAC Measurement Results

Lower Band (Channel 526):

Frequency (MHz): 819.100000

Probe Modulation Factor = 0.870000

Maximum value of total field = 129.08 V/m

Hearing Aid Near-Field Category: M4 (AWF 0 dB)

SURFACE HAC

E in V/m

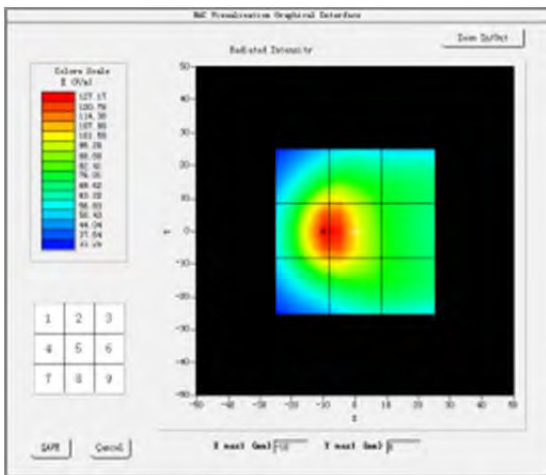

Grid 1: 102.48	Grid 2: 103.07	Grid 3: 78.89
Grid 4: 129.57	Grid 5: 129.08	Grid 6: 82.01
Grid 7: 111.11	Grid 8: 111.50	Grid 9: 82.05

MEASUREMENT 9

Experimental conditions

Grid size (mm x mm)	50.0, 50.0
Step (mm)	5
Band	BC10_Secondary_800MHz
Channel	High
Signal	CDMA
Date of measurement	2014-05-20

HAC Measurement Results

Lower Band (Channel 684):

Frequency (MHz): 823.10000

Probe Modulation Factor = 0.870000

Maximum value of total field = 128.30 V/m

Hearing Aid Near-Field Category: M4 (AWF 0 dB)

SURFACE HAC

E in V/m

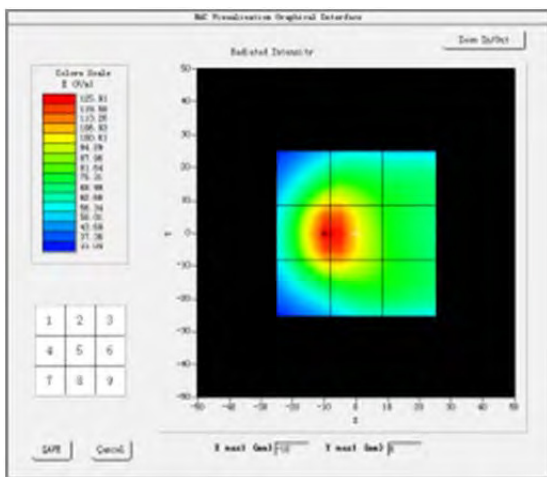

Grid 1: 101.75	Grid 2: 102.01	Grid 3: 79.06
Grid 4: 128.61	Grid 5: 128.30	Grid 6: 81.98
Grid 7: 110.97	Grid 8: 111.17	Grid 9: 82.17

MEASUREMENT 10

Experimental conditions

Grid size (mm x mm)	50.0, 50.0
Step (mm)	5
Band	BC10_Secondary_800MHz
Channel	Low
Signal	CDMA
Date of measurement	2014-05-20

HAC Measurement Results

Lower Band (Channel 476):

Frequency (MHz): 817.90000

Probe Modulation Factor = 0.900000

Maximum value of total field = 0.32 A/m

Hearing Aid Near-Field Category: M4 (AWF 0 dB)

SURFACE HAC

H in A/m

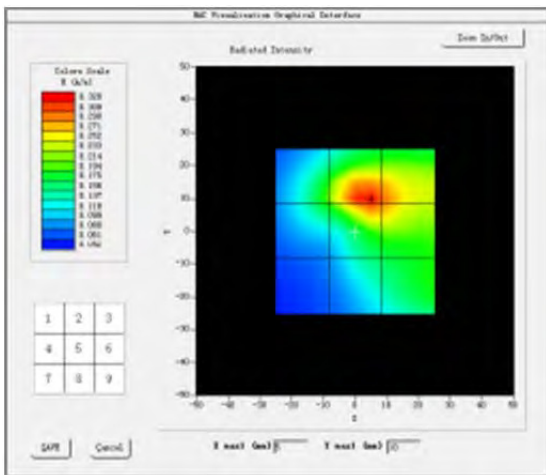

Grid 1: 0.22	Grid 2: 0.33	Grid 3: 0.29
Grid 4: 0.21	Grid 5: 0.32	Grid 6: 0.29
Grid 7: 0.08	Grid 8: 0.17	Grid 9: 0.20

MEASUREMENT 11

Experimental conditions

Grid size (mm x mm)	50.0, 50.0
Step (mm)	5
Band	BC10_Secondary_800MHz
Channel	Middle
Signal	CDMA
Date of measurement	2014-05-20

HAC Measurement Results

Lower Band (Channel 526):

Frequency (MHz): 819.10000

Probe Modulation Factor = 0.900000

Maximum value of total field = 0.28 A/m

Hearing Aid Near-Field Category: M4 (AWF 0 dB)

SURFACE HAC

H in A/m

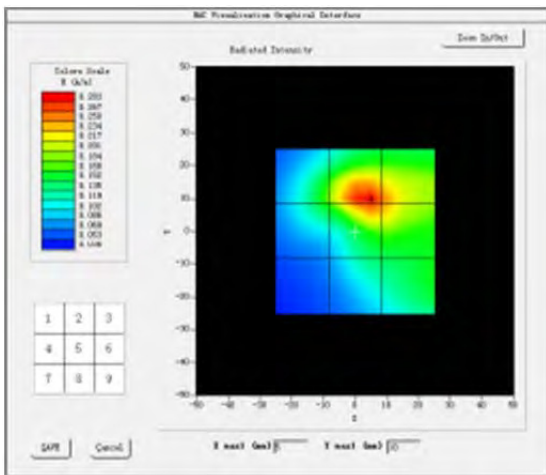

Grid 1: 0.19	Grid 2: 0.29	Grid 3: 0.24
Grid 4: 0.18	Grid 5: 0.28	Grid 6: 0.24
Grid 7: 0.07	Grid 8: 0.14	Grid 9: 0.16

MEASUREMENT 12

Experimental conditions

Grid size (mm x mm)	50.0, 50.0
Step (mm)	5
Band	BC10_Secondary_800MHz
Channel	High
Signal	CDMA
Date of measurement	2014-05-20

HAC Measurement Results

Lower Band (Channel 684):

Frequency (MHz): 823.10000

Probe Modulation Factor = 0.900000

Maximum value of total field = 0.28 A/m

Hearing Aid Near-Field Category: M4 (AWF 0 dB)

SURFACE HAC

H in A/m

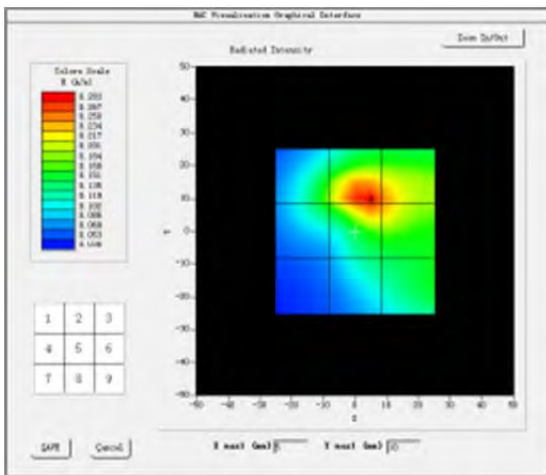

Grid 1: 0.19	Grid 2: 0.28	Grid 3: 0.24
Grid 4: 0.18	Grid 5: 0.29	Grid 6: 0.25
Grid 7: 0.08	Grid 8: 0.14	Grid 9: 0.16

MEASUREMENT 13

Experimental conditions

Grid size (mm x mm)	50.0, 50.0
Step (mm)	5
Band	BC1_North_American_PCS
Channel	Low
Signal	CDMA
Date of measurement	2014-05-20

HAC Measurement Results

Lower Band (Channel 25):

Frequency (MHz): 1851.25000

Probe Modulation Factor = 0.890000

Maximum value of total field = 37.55 V/m

Hearing Aid Near-Field Category: M4 (AWF 0 dB)

SURFACE HAC

E in V/m

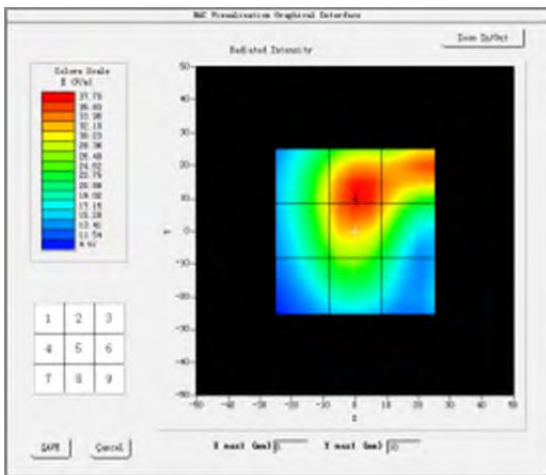

Grid 1: 31.53	Grid 2: 38.10	Grid 3: 36.10
Grid 4: 31.48	Grid 5: 37.55	Grid 6: 32.05
Grid 7: 24.75	Grid 8: 27.47	Grid 9: 21.22

MEASUREMENT 14

Experimental conditions

Grid size (mm x mm)	50.0, 50.0
Step (mm)	5
Band	BC1_North_American_PCS
Channel	Middle
Signal	CDMA
Date of measurement	2014-05-20

HAC Measurement Results

Lower Band (Channel 600):

Frequency (MHz): 1880.00000

Probe Modulation Factor = 0.890000

Maximum value of total field = 33.29 V/m

Hearing Aid Near-Field Category: M4 (AWF 0 dB)

SURFACE HAC

E in V/m

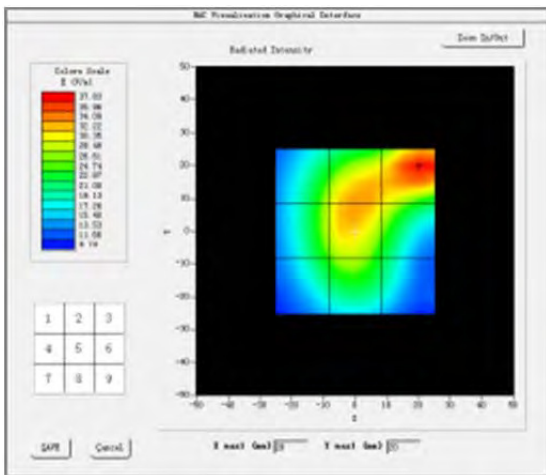

Grid 1: 28.54	Grid 2: 33.28	Grid 3: 37.93
Grid 4: 29.35	Grid 5: 33.29	Grid 6: 30.03
Grid 7: 25.91	Grid 8: 28.57	Grid 9: 21.65

MEASUREMENT 15

Experimental conditions

Grid size (mm x mm)	50.0, 50.0
Step (mm)	5
Band	BC1_North_American_PCS
Channel	High
Signal	CDMA
Date of measurement	2014-05-20

HAC Measurement Results

Lower Band (Channel 1175):

Frequency (MHz): 1908.75000

Probe Modulation Factor = 0.890000

Maximum value of total field = 32.11 V/m

Hearing Aid Near-Field Category: M4 (AWF 0 dB)

SURFACE HAC

E in V/m

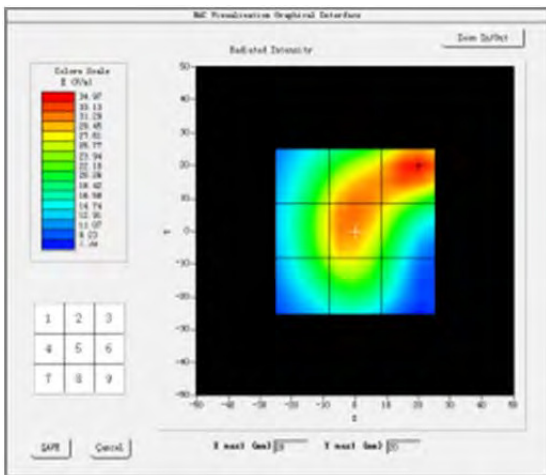

Grid 1: 26.77	Grid 2: 31.65	Grid 3: 35.13
Grid 4: 28.72	Grid 5: 32.11	Grid 6: 28.67
Grid 7: 25.94	Grid 8: 28.21	Grid 9: 20.32

MEASUREMENT 16

Experimental conditions

Grid size (mm x mm)	50.0, 50.0
Step (mm)	5
Band	BC1_North_American_PCS
Channel	Low
Signal	CDMA
Date of measurement	2014-05-20

HAC Measurement Results

Lower Band (Channel 25):

Frequency (MHz): 1851.25000

Probe Modulation Factor = 0.880000

Maximum value of total field = 0.10 A/m

Hearing Aid Near-Field Category: M4 (AWF 0 dB)

SURFACE HAC

H in A/m

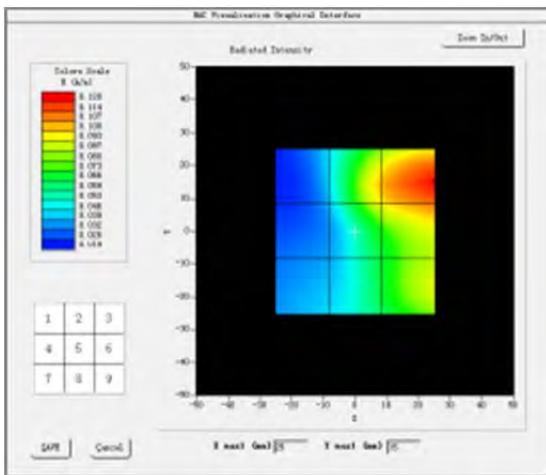

Grid 1: 0.04	Grid 2: 0.10	Grid 3: 0.12
Grid 4: 0.04	Grid 5: 0.10	Grid 6: 0.11
Grid 7: 0.04	Grid 8: 0.07	Grid 9: 0.09

MEASUREMENT 17

Experimental conditions

Grid size (mm x mm)	50.0, 50.0
Step (mm)	5
Band	BC1_North_American_PCS
Channel	Middle
Signal	CDMA
Date of measurement	2014-05-20

HAC Measurement Results

Lower Band (Channel 600):

Frequency (MHz): 1880.00000

Probe Modulation Factor = 0.880000

Maximum value of total field = 0.08 A/m

Hearing Aid Near-Field Category: M4 (AWF 0 dB)

SURFACE HAC

H in A/m

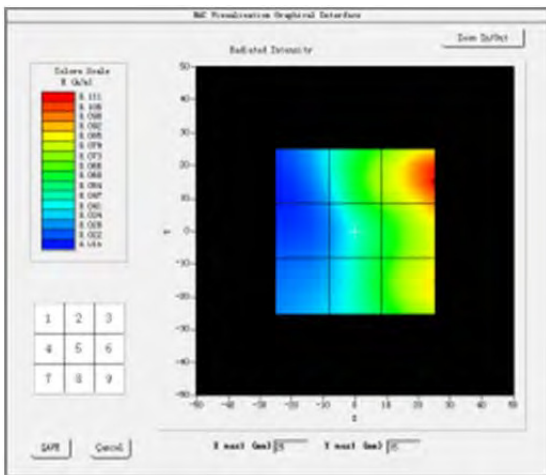

Grid 1: 0.04	Grid 2: 0.08	Grid 3: 0.11
Grid 4: 0.03	Grid 5: 0.07	Grid 6: 0.10
Grid 7: 0.04	Grid 8: 0.07	Grid 9: 0.09

MEASUREMENT 18

Experimental conditions

Grid size (mm x mm)	50.0, 50.0
Step (mm)	5
Band	BC1_North_American_PCS
Channel	High
Signal	CDMA
Date of measurement	2014-05-20

HAC Measurement Results

Lower Band (Channel 1175):

Frequency (MHz): 1908.75000

Probe Modulation Factor = 0.880000

Maximum value of total field = 0.07 A/m

Hearing Aid Near-Field Category: M4 (AWF 0 dB)

SURFACE HAC

H in A/m

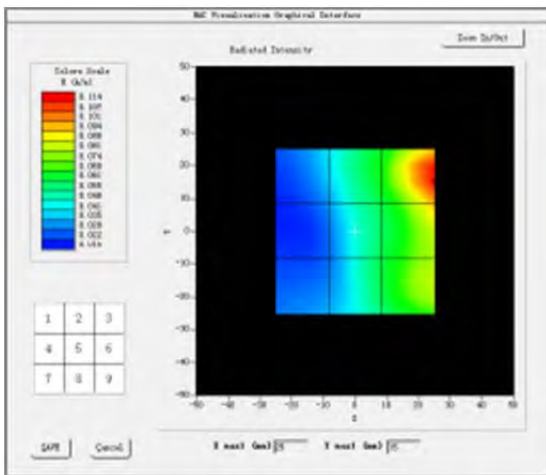

Grid 1: 0.04	Grid 2: 0.07	Grid 3: 0.12
Grid 4: 0.03	Grid 5: 0.06	Grid 6: 0.10
Grid 7: 0.03	Grid 8: 0.06	Grid 9: 0.08

ANNEX D CALIBRATION FOR PROBE AND DIPOLE



COMOHAC E-Field Probe Calibration Report

Ref: ACR.219.13.13.SATU.A

SHENZHEN BALUN TECHNOLOGY CO., LTD.
ROOM 601, EAST TOWER, NANSHAN SOFTWARE PARK,
10128 SHENNAN ROAD, SHENZHEN, 518084, CHINA
SATIMO COMOHAC E-FIELD PROBE
SERIAL NO.: SN 24/13 EPH41

Calibrated at SATIMO US
2105 Barrett Park Dr. - Kennesaw, GA 30144



07/08/2013

Summary:

This document presents the method and results from an accredited COMOHAC E-Field Probe calibration performed in SATIMO USA using the CALIBAIR test bench, for use with a SATIMO COMOHAC system only. All calibration results are traceable to national metrology institutions.



COMOHAC E-FIELD PROBE CALIBRATION REPORT

Ref: ACR.219.13.13.SATULA

	<i>Name</i>	<i>Function</i>	<i>Date</i>	<i>Signature</i>
<i>Prepared by :</i>	Jérôme LUC	Product Manager	8/7/2013	<i>JS</i>
<i>Checked by :</i>	Jérôme LUC	Product Manager	8/7/2013	<i>JS</i>
<i>Approved by :</i>	Kim RUTKOWSKI	Quality Manager	8/7/2013	<i>Kim Rutkowski</i>

	<i>Customer Name</i>
<i>Distribution :</i>	Shenzhen BALUN Technology Co., Ltd.

<i>Issue</i>	<i>Date</i>	<i>Modifications</i>
A	8/7/2013	Initial release



**TABLE OF CONTENTS**

1	Device Under Test	4
2	Product Description	4
2.1	General Information	4
3	Measurement Method	4
3.1	Linearity	4
3.2	Sensitivity	4
3.3	Isotropy	5
3.4	Probe Modulation Response	5
4	Measurement Uncertainty	5
5	Calibration Measurement Results	5
5.1	Sensitivity in air	6
5.2	Linearity	7
5.3	Isotropy	7
6	List of Equipment	8





1 DEVICE UNDER TEST

Device Under Test	
Device Type	COMOHAC E FIELD PROBE
Manufacturer	Satimo
Model	SCE
Serial Number	SN 24/13 EPH41
Product Condition (new / used)	New
Frequency Range of Probe	0.7GHz-2.5GHz
Resistance of Three Dipoles at Connector	Dipole 1: R1=1.265 MΩ Dipole 2: R2=1.267 MΩ Dipole 3: R3=1.228 MΩ

A yearly calibration interval is recommended.

2 PRODUCT DESCRIPTION

2.1 GENERAL INFORMATION

Satimo's COMOHAC E field Probes are built in accordance to the ANSI C63.19 and IEEE 1309 standards.



Figure 1 – Satimo COMOHAC E field Probe

Probe Length	330 mm
Length of Individual Dipoles	3.3 mm
Maximum external diameter	8 mm
Probe Tip External Diameter	5 mm
Distance between dipoles / probe extremity	3 mm

3 MEASUREMENT METHOD

All methods used to perform the measurements and calibrations comply with the ANSI C63.19 and IEEE 1309 standards.

3.1 LINEARITY

The linearity was determined using a standard dipole with the probe positioned 10 mm above the dipole. The input power of the dipole was adjusted from -15 to 36 dBm using a 1dB step (to cover the range 2V/m to 1000A/m).

3.2 SENSITIVITY

The sensitivity factors of the three dipoles were determined using the waveguide method outlined in the fore mentioned standards.

Page: 4/8



This document shall not be reproduced, except in full or in part, without the written approval of SATIMO.
The information contained herein is to be used only for the purpose for which it is submitted and is not to be released in whole or part without written approval of SATIMO.





3.3 ISOTROPY

The axial isotropy was evaluated by exposing the probe to a reference wave from a standard dipole. The probe was rotated along its main axis from 0 - 360 degrees in 15 degree steps.

3.4 PROBE MODULATION RESPONSE

The modulation factor was determined by illuminating the probe with a reference wave from a standard dipole 10 mm away, applying first a CW signal and then a modulated signal (both at same power level). The modulation factor is the ratio, in linear units, of the CW to modulated signal reading.

4 MEASUREMENT UNCERTAINTY

The guidelines outlined in the IEEE 1528 and IEC/CEI 62209 standards were followed to generate the measurement uncertainty associated with an E-field probe calibration using the waveguide technique. All uncertainties listed below represent an expanded uncertainty expressed at approximately the 95% confidence level using a coverage factor of k=2, traceable to the Internationally Accepted Guides to Measurement Uncertainty.

Uncertainty analysis of the probe calibration in waveguide					
ERROR SOURCES	Uncertainty value (%)	Probability Distribution	Divisor	ci	Standard Uncertainty (%)
Incident or forward power	3.00%	Rectangular	$\sqrt{3}$	1	1.732%
Reflected power	3.00%	Rectangular	$\sqrt{3}$	1	1.732%
Field homogeneity	3.00%	Rectangular	$\sqrt{3}$	1	1.732%
Field probe positioning	5.00%	Rectangular	$\sqrt{3}$	1	2.887%
Field probe linearity	3.00%	Rectangular	$\sqrt{3}$	1	1.732%
Combined standard uncertainty					4.509%
Expanded uncertainty 95 % confidence level k = 2					9.0%

5 CALIBRATION MEASUREMENT RESULTS

Calibration Parameters	
Lab Temperature	21 °C
Lab Humidity	45 %

Page: 5/8



This document shall not be reproduced, except in full or in part, without the written approval of SATIMO. The information contained herein is to be used only for the purpose for which it is submitted and is not to be released in whole or part without written approval of SATIMO.





5.1 SENSITIVITY IN AIR

Normx dipole 1 ($\mu\text{V}/(\text{V}/\text{m})^2$)	Normy dipole 2 ($\mu\text{V}/(\text{V}/\text{m})^2$)	Normz dipole 3 ($\mu\text{V}/(\text{V}/\text{m})^2$)
6.54	4.86	5.80

DCP dipole 1 (mV)	DCP dipole 2 (mV)	DCP dipole 3 (mV)
96	96	92

Calibration curves

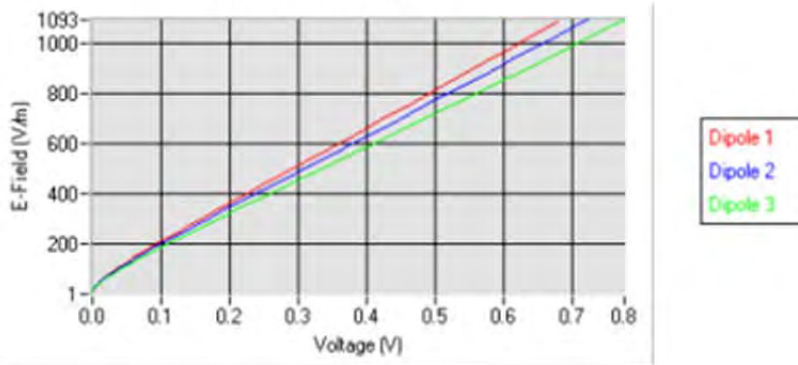



5.2 LINEARITY

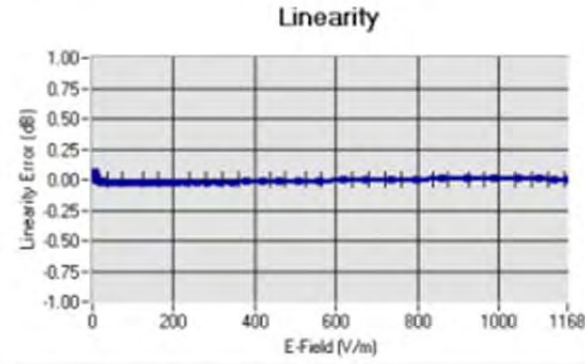

Linearity $\pm 1.49\%$ ($\pm 0.07\text{dB}$)

5.3 ISOTROPY

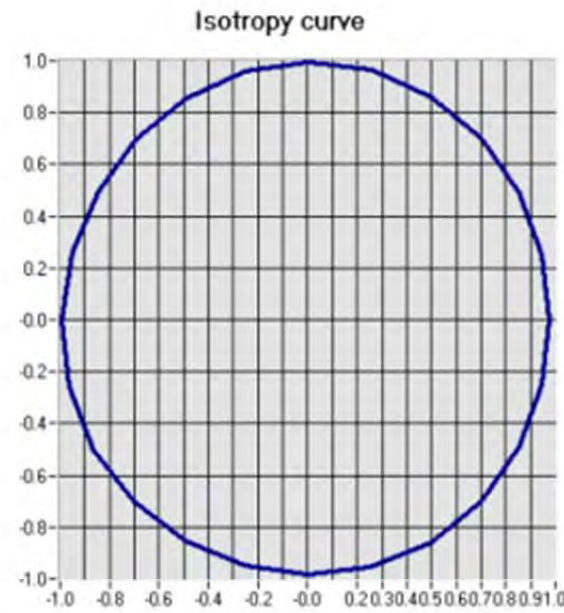

Isotropy $\pm 1.22\%$ ($\pm 0.05\text{dB}$)



6 LIST OF EQUIPMENT

Equipment Summary Sheet				
Equipment Description	Manufacturer / Model	Identification No.	Current Calibration Date	Next Calibration Date
HAC positioning ruler	Satimo	TABH12 SN 42/09	Validated. No cal required.	Validated. No cal required.
COMOHAC Test Bench	Version 2	NA	Validated. No cal required.	Validated. No cal required.
Network Analyzer	Rhode & Schwarz ZVA	SN100132	02/2013	02/2016
Reference Probe	Satimo	EPH28 SN 08/11	Characterized prior to test. No cal required.	Characterized prior to test. No cal required.
Reference Probe	Satimo	HPH38 SN31/10	Characterized prior to test. No cal required.	Characterized prior to test. No cal required.
Multimeter	Keithley 2000	1188656	11/2010	11/2013
Signal Generator	Agilent E4438C	MY49070581	12/2010	12/2013
Amplifier	Aethercomm	SN 046	Characterized prior to test. No cal required.	Characterized prior to test. No cal required.
Power Meter	HP E4418A	US38261498	11/2010	11/2013
Power Sensor	HP ECP-E26A	US37181460	11/2010	11/2013
Directional Coupler	Narda 4216-20	01386	Characterized prior to test. No cal required.	Characterized prior to test. No cal required.
Waveguide	Mega Industries	069Y7-158-13-712	Validated. No cal required.	Validated. No cal required.
Waveguide Transition	Mega Industries	069Y7-158-13-701	Validated. No cal required.	Validated. No cal required.
Waveguide Termination	Mega Industries	069Y7-158-13-701	Validated. No cal required.	Validated. No cal required.
Temperature / Humidity Sensor	Control Company	11-661-9	3/2012	3/2014

Page: 8/8



This document shall not be reproduced, except in full or in part, without the written approval of SATIMO. The information contained herein is to be used only for the purpose for which it is submitted and is not to be released in whole or part without written approval of SATIMO.





COMOHAC H-Field Probe Calibration

Ref: ACR.219.14.13.SATU.A

SHENZHEN BALUN TECHNOLOGY CO., LTD.
ROOM 601, EAST TOWER, NANSHAN SOFTWARE PARK,
10128 SHENNAN ROAD, SHENZHEN, 518084, CHINA
SATIMO COMOHAC H-FIELD PROBE
SERIAL NO.: SN 24/13 HPH49

Calibrated at SATIMO US
2105 Barrett Park Dr. - Kennesaw, GA 30144



07/08/2013

Summary:

This document presents the method and results from an accredited COMOHAC H-Field Probe calibration performed in SATIMO USA using the CALIBAIR test bench, for use with a SATIMO COMOHAC system only. All calibration results are traceable to national metrology institutions.



COMOHAC H-FIELD PROBE CALIBRATION REPORT

Ref: ACR.219.14.13.SATULA

	<i>Name</i>	<i>Function</i>	<i>Date</i>	<i>Signature</i>
<i>Prepared by :</i>	Jérôme LUC	Product Manager	8/7/2013	<i>JS</i>
<i>Checked by :</i>	Jérôme LUC	Product Manager	8/7/2013	<i>JS</i>
<i>Approved by :</i>	Kim RUTKOWSKI	Quality Manager	8/7/2013	<i>Kim Rutkowski</i>

	<i>Customer Name</i>
<i>Distribution :</i>	Shenzhen BALUN Technology Co., Ltd.

<i>Issue</i>	<i>Date</i>	<i>Modifications</i>
A	8/7/2013	Initial release

Page: 2/9



This document shall not be reproduced, except in full or in part, without the written approval of SATIMO.
The information contained herein is to be used only for the purpose for which it is submitted and is not to be released in whole or part without written approval of SATIMO.



1 DEVICE UNDER TEST

Device Under Test	
Device Type	COMOHAC H FIELD PROBE
Manufacturer	Satimo
Model	SCH
Serial Number	SN 24/13 HPH49
Product Condition (new / used)	New
Frequency Range of Probe	0.7GHz-2.5GHz
Resistance of Three Loops at Connector	Loop 1: R1=0.289 MΩ Loop 2: R2=0.287 MΩ Loop 3: R3=0.281 MΩ

A yearly calibration interval is recommended.

2 PRODUCT DESCRIPTION

2.1 GENERAL INFORMATION

Satimo's COMOHAC H field Probes are built in accordance to the ANSI C63.19 and IEEE 1309 standards.



Figure 1 – Satimo COMOHAC H field Probe

Probe Length	330 mm
Dimension of one loop	3.3 mm
Maximum external diameter	8 mm
Probe Tip External Diameter	5 mm
Distance between loops / probe extremity	3 mm

3 MEASUREMENT METHOD

All methods used to perform the measurements and calibrations comply with the ANSI C63.19 and IEEE 1309 standards.

3.1 LINEARITY

The linearity was determined using a standard dipole with the probe positioned 10 mm above the dipole. The input power of the dipole was adjusted from -15 to 36 dBm using a 1dB step (to cover the range 0.01A/m to 2A/m).



3.2 SENSITIVITY

The sensitivity factors of the three loops were determined using the waveguide method outlined in the fore mentioned standards.

3.3 ISOTROPY

The axial isotropy was evaluated by exposing the probe to a reference wave from a standard dipole. The probe was rotated along its main axis from 0 - 360 degrees in 15 degree steps.

3.4 PROBE MODULATION RESPONSE

The modulation factor was determined by illuminating the probe with a reference wave from a standard dipole 10 mm away, applying first a CW signal and then a modulated signal (both at same power level). The modulation factor is the ratio, in linear units, of the CW to modulated signal reading.

4 MEASUREMENT UNCERTAINTY

The guidelines outlined in the IEEE 1528 and IEC/CEI 62209 standards were followed to generate the measurement uncertainty associated with an H-field probe calibration using the waveguide technique. All uncertainties listed below represent an expanded uncertainty expressed at approximately the 95% confidence level using a coverage factor of k=2, traceable to the Internationally Accepted Guides to Measurement Uncertainty.

Uncertainty analysis of the probe calibration in waveguide					
ERROR SOURCES	Uncertainty value (%)	Probability Distribution	Divisor	ci	Standard Uncertainty (%)
Incident or forward power	3.00%	Rectangular	$\sqrt{3}$	1	1.732%
Reflected power	3.00%	Rectangular	$\sqrt{3}$	1	1.732%
Field homogeneity	3.00%	Rectangular	$\sqrt{3}$	1	1.732%
Field probe positioning	5.00%	Rectangular	$\sqrt{3}$	1	2.887%
Field probe linearity	3.00%	Rectangular	$\sqrt{3}$	1	1.732%
Combined standard uncertainty					4.509%
Expanded uncertainty 95 % confidence level k = 2					9.0%

5 CALIBRATION MEASUREMENT RESULTS

Calibration Parameters	
Lab Temperature	21 °C
Lab Humidity	45 %

Page: 5/9



This document shall not be reproduced, except in full or in part, without the written approval of SATIMO.
The information contained herein is to be used only for the purpose for which it is submitted and is not to be released in whole or part without written approval of SATIMO.





5.1 SENSITIVITY IN AIR

Frequency	Normx loop 1 (mV/(A/m) ²)	Normy loop 2 (mV/(A/m) ²)	Normz loop 3 (mV/(A/m) ²)
0.7-1.0 GHz	0.062	0.072	0.068
1.7-2.5 GHz	0.35	0.41	0.37

DCP dipole 1 (mV)	DCP dipole 2 (mV)	DCP dipole 3 (mV)
112	102	106

Calibration curves

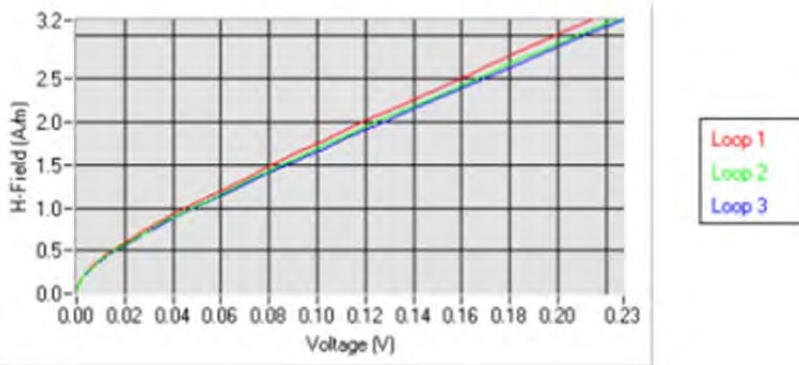

Calibration curves at 835 MHz

Calibration curves

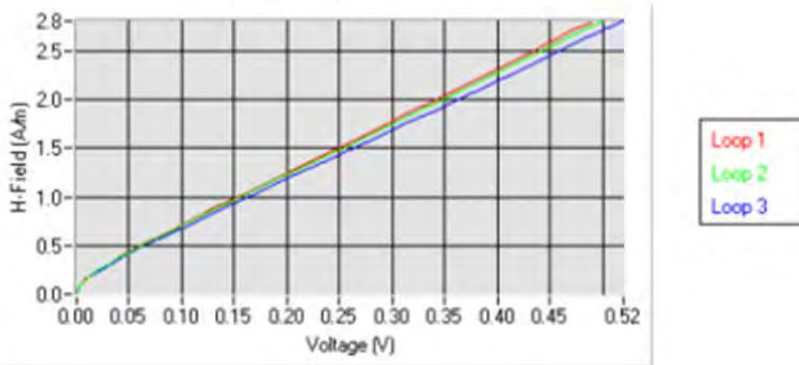

Calibration curves at 1900 MHz





5.2 LINEARITY

Linearity

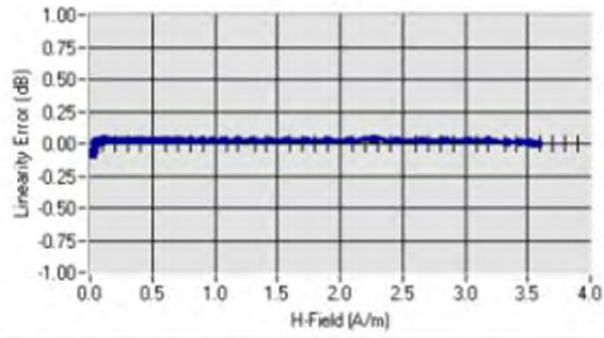

Linearity: $\pm 1.83\%$ ($\pm 0.08\text{dB}$)

Linearity at 835 MHz

Linearity

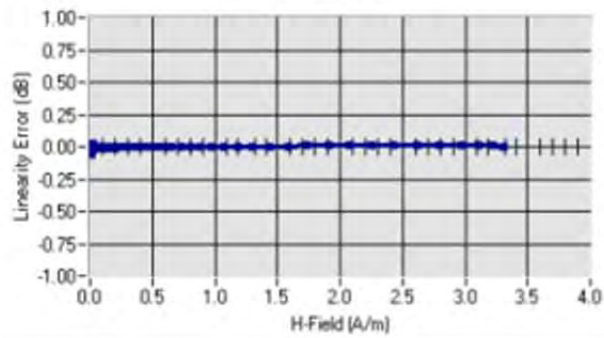

Linearity: $\pm 1.36\%$ ($\pm 0.06\text{dB}$)

Linearity at 1900 MHz





5.3 ISOTROPY

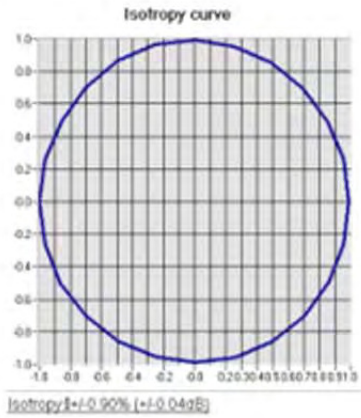

Isotropy at 835 MHz

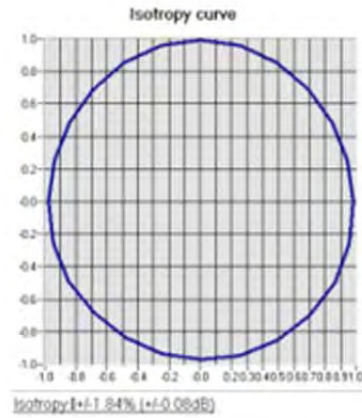

Isotropy at 1900 MHz



6 LIST OF EQUIPMENT

Equipment Summary Sheet				
Equipment Description	Manufacturer / Model	Identification No.	Current Calibration Date	Next Calibration Date
HAC positioning ruler	Satimo	TABH12 SN 42/09	Validated. No cal required.	Validated. No cal required.
COMOHAC Test Bench	Version 2	NA	Validated. No cal required.	Validated. No cal required.
Network Analyzer	Rhode & Schwarz ZVA	SN100132	02/2013	02/2016
Reference Probe	Satimo	EPH28 SN 08/11	Characterized prior to test. No cal required.	Characterized prior to test. No cal required.
Reference Probe	Satimo	HPH38 SN31/10	Characterized prior to test. No cal required.	Characterized prior to test. No cal required.
Multimeter	Keithley 2000	1188656	11/2010	11/2013
Signal Generator	Agilent E4438C	MY49070581	12/2010	12/2013
Amplifier	Aethercomm	SN 046	Characterized prior to test. No cal required.	Characterized prior to test. No cal required.
Power Meter	HP E4418A	US38261498	11/2010	11/2013
Power Sensor	HP ECP-E26A	US37181460	11/2010	11/2013
Directional Coupler	Narda 4216-20	01386	Characterized prior to test. No cal required.	Characterized prior to test. No cal required.
Waveguide	Mega Industries	069Y7-158-13-712	Validated. No cal required.	Validated. No cal required.
Waveguide Transition	Mega Industries	069Y7-158-13-701	Validated. No cal required.	Validated. No cal required.
Waveguide Termination	Mega Industries	069Y7-158-13-701	Validated. No cal required.	Validated. No cal required.
Temperature / Humidity Sensor	Control Company	11-661-9	3/2012	3/2014

Page: 9/9



This document shall not be reproduced, except in full or in part, without the written approval of SATIMO. The information contained herein is to be used only for the purpose for which it is submitted and is not to be released in whole or part without written approval of SATIMO.





HAC Reference Dipole Calibration Report

Ref : ACR.219.16.13.SATU.A

SHENZHEN BALUN TECHNOLOGY CO., LTD.
ROOM 601, EAST TOWER, NANSHAN SOFTWARE PARK,
10128 SHENNAN ROAD, SHENZHEN, 518084, CHINA
SATIMO COMOHAC REFERENCE DIPOLE
FREQUENCY: 800-950MHZ
SERIAL NO.: SN 18/12 DHA41

Calibrated at SATIMO US
2105 Barrett Park Dr. - Kennesaw, GA 30144



07/08/2013

Summary:

This document presents the method and results from an accredited HAC reference dipole calibration performed in SATIMO USA using the COMOHAC test bench. All calibration results are traceable to national metrology institutions.



HAC REFERENCE DIPOLE CALIBRATION REPORT

Ref: ACR.219.16.13.SATULA

	<i>Name</i>	<i>Function</i>	<i>Date</i>	<i>Signature</i>
<i>Prepared by :</i>	Jérôme LUC	Product Manager	8/7/2013	<i>JS</i>
<i>Checked by :</i>	Jérôme LUC	Product Manager	8/7/2013	<i>JS</i>
<i>Approved by :</i>	Kim RUTKOWSKI	Quality Manager	8/7/2013	<i>Kim Rutkowski</i>

	<i>Customer Name</i>
<i>Distribution :</i>	Shenzhen BALUN Technology Co., Ltd.

<i>Issue</i>	<i>Date</i>	<i>Modifications</i>
A	8/7/2013	Initial release



**TABLE OF CONTENTS**

1	Introduction.....	4
2	Device Under TEst.....	4
3	Product Description	4
3.1	General Information	4
4	Measurement Method	4
4.1	Return Loss Requirements	5
4.2	Reference Dipole Calibration	5
5	Measurement Uncertainty	5
5.1	Return Loss	5
5.2	Validation Measurement	5
6	Calibration Measurement Results	6
6.1	Return Loss	6
6.2	Validation measurement	6
7	List of Equipment	8





1 INTRODUCTION

This document contains a summary of the requirements set forth by the ANSI C63.19 standard for reference dipoles used for HAC measurement system validations and the measurements that were performed to verify that the product complies with the fore mentioned standards.

2 DEVICE UNDER TEST

Device Under Test	
Device Type	COMOHAC 800-950 MHz REFERENCE DIPOLE
Manufacturer	Satimo
Model	SIDB835
Serial Number	SN 18/12 DHA41
Product Condition (new / used)	New

A yearly calibration interval is recommended.

3 PRODUCT DESCRIPTION

3.1 GENERAL INFORMATION

Satimo's COMOHAC Validation Dipoles are built in accordance to the ANSI C63.19 standard. The product is designed for use with the COMOHAC system only.



Figure 1 – Satimo COMOHAC Validation Dipole

4 MEASUREMENT METHOD

The ANSI C63.19 standard outlines the requirements for reference dipoles to be used for system validation measurements. The following measurements were performed to verify that the product complies with the fore mentioned standard.

Page: 4/8



This document shall not be reproduced, except in full or in part, without the written approval of SATIMO. The information contained herein is to be used only for the purpose for which it is submitted and is not to be released in whole or part without written approval of SATIMO.





4.1 RETURN LOSS REQUIREMENTS

The dipole used for HAC system validation measurements and checks must have a return loss of -10 dB or better. The return loss measurement shall be performed in free space.

4.2 REFERENCE DIPOLE CALIBRATION

The IEEE ANSI C63-19 standard states that the dipole used for validation measurements and checks must be scanned with the E and H field probe, with the dipole 10 mm below the probe. The E and H field strength plots are compared to the simulation results obtained by SATIMO.

5 MEASUREMENT UNCERTAINTY

All uncertainties listed below represent an expanded uncertainty expressed at approximately the 95% confidence level using a coverage factor of $k=2$, traceable to the Internationally Accepted Guides to Measurement Uncertainty.

5.1 RETURN LOSS

The following uncertainties apply to the return loss measurement:

Frequency band	Expanded Uncertainty on Gain
400-6000MHz	0.1 dB

5.2 VALIDATION MEASUREMENT

The guideline outlined in the IEEE ANSI C63.19 standard was followed to generate the measurement uncertainty for validation measurements.

Uncertainty analysis of the probe calibration in waveguide					
ERROR SOURCES	Uncertainty value (%)	Probability Distribution	Divisor	Uncertainty (dB)	Standard Uncertainty (%)
RF reflections	0.1	R	$\sqrt{3}$	0.06	
Field probe conv. Factor	0.4	R	$\sqrt{3}$	0.23	
Field probe anisotropy	0.25	R	$\sqrt{3}$	0.14	
Positioning accuracy	0.2	R	$\sqrt{3}$	0.12	
Probe cable placement	0.1	R	$\sqrt{3}$	0.06	
System repeatability	0.2	R	$\sqrt{3}$	0.12	
EUT repeatability	0.4	N	1	0.40	
Combined standard uncertainty				0.52	
Expanded uncertainty 95 % confidence level $k = 2$				1.00	13.0



6 CALIBRATION MEASUREMENT RESULTS

6.1 RETURN LOSS

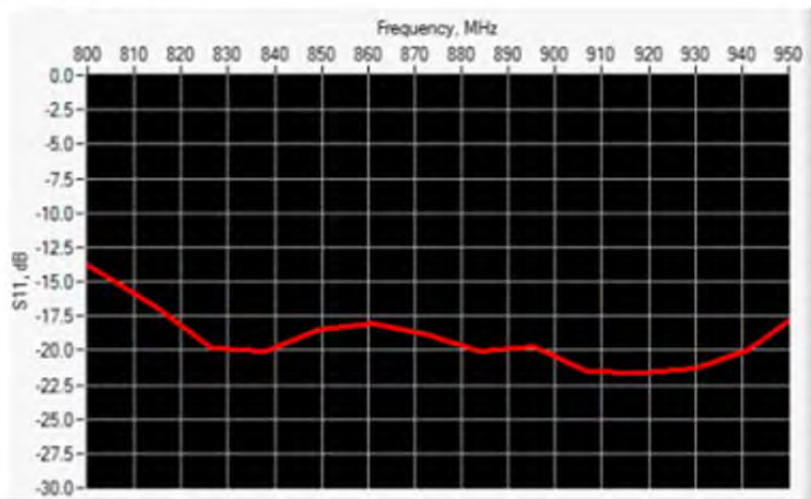

Frequency (MHz)	Worst Case Return Loss (dB)	Requirement (dB)
800-950 MHz	-14.55	-10

6.2 VALIDATION MEASUREMENT

The IEEE ANSI C63.19 standard states that the system validation measurements must be performed using a reference dipole meeting the fore mentioned return loss requirements. The system validations measurement results are then compared to SATIMO's simulated results.

Measurement Condition

Software Version	OpenHAC V2
HAC positioning ruler	SN 42/09 TABH12
E-Field probe	SN 08/11 EPH28
H-Field probe	SN 31/10 HPH38
Distance between dipole and sensor center	10 mm
E-field scan size	X=150mm/Y=20mm
H-field scan size	X=40mm/Y=20mm
Scan resolution	dx=5mm/dy=5mm
Frequency	835 MHz
Input power	20 dBm
Lab Temperature	21°C
Lab Humidity	45%



Measurement Result

	Measured	Internal Requirement
E field (V/m)	214.61	220.4
H field (A/m)	0.43	0.445

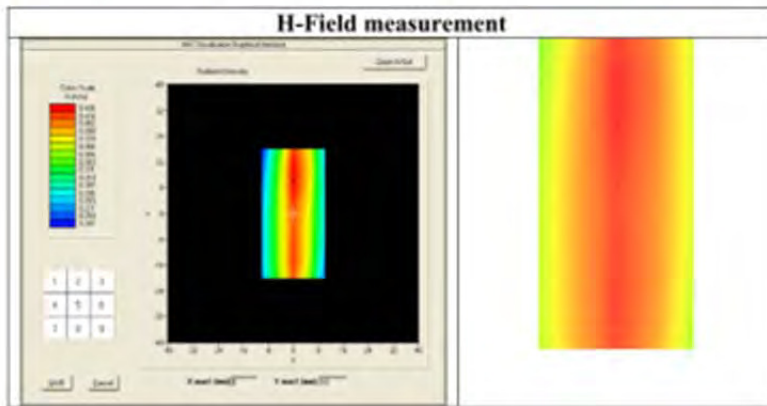
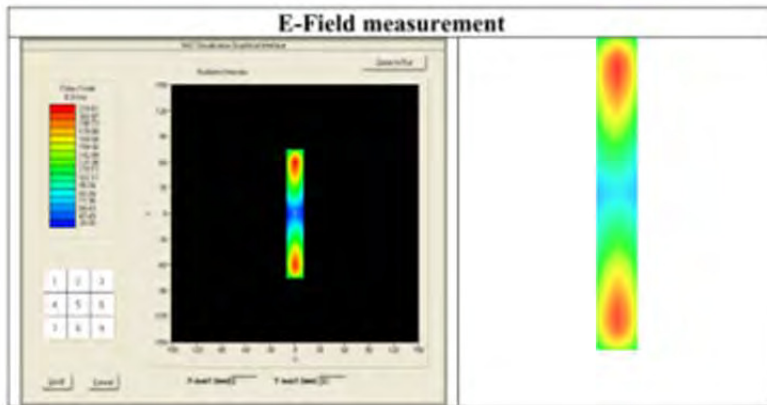

7 LIST OF EQUIPMENT

Equipment Summary Sheet				
Equipment Description	Manufacturer / Model	Identification No.	Current Calibration Date	Next Calibration Date
HAC positioning ruler	Satimo	TABH12 SN 42/09	Validated. No cal required.	Validated. No cal required.
COMOHAC Test Bench	Version 2	NA	Validated. No cal required.	Validated. No cal required.
Network Analyzer	Rhode & Schwarz ZVA	SN100132	02/2013	02/2016
Reference Probe	Satimo	EPH28 SN 08/11	Characterized prior to test. No cal required.	Characterized prior to test. No cal required.
Reference Probe	Satimo	HPH38 SN31/10	Characterized prior to test. No cal required.	Characterized prior to test. No cal required.
Multimeter	Keithley 2000	1188656	11/2010	11/2013
Signal Generator	Agilent E4438C	MY49070581	12/2010	12/2013
Amplifier	Aethercomm	SN 046	Characterized prior to test. No cal required.	Characterized prior to test. No cal required.
Power Meter	HP E4418A	US38261498	11/2010	11/2013
Power Sensor	HP ECP-E26A	US37181460	11/2010	11/2013
Directional Coupler	Narda 4216-20	01386	Characterized prior to test. No cal required.	Characterized prior to test. No cal required.
Temperature and Humidity Sensor	Control Company	11-661-9	3/2012	3/2014





HAC Reference Dipole Calibration Report

Ref : ACR.219.17.13.SATU.A

SHENZHEN BALUN TECHNOLOGY CO., LTD.
ROOM 601, EAST TOWER, NANSHAN SOFTWARE PARK,
10128 SHENNAN ROAD, SHENZHEN, 518084, CHINA
SATIMO COMOHAC REFERENCE DIPOLE
FREQUENCY: 1700-2000MHZ
SERIAL NO.: SN 18/12 DHB46

Calibrated at SATIMO US
2105 Barrett Park Dr. - Kennesaw, GA 30144



07/08/2013

Summary:

This document presents the method and results from an accredited HAC reference dipole calibration performed in SATIMO USA using the COMOHAC test bench. All calibration results are traceable to national metrology institutions.



HAC REFERENCE DIPOLE CALIBRATION REPORT

Ref: ACR.219.17.13.SATU.A

	<i>Name</i>	<i>Function</i>	<i>Date</i>	<i>Signature</i>
<i>Prepared by :</i>	Jérôme LUC	Product Manager	8/7/2013	<i>JS</i>
<i>Checked by :</i>	Jérôme LUC	Product Manager	8/7/2013	<i>JS</i>
<i>Approved by :</i>	Kim RUTKOWSKI	Quality Manager	8/7/2013	<i>Kim Rutkowski</i>

	<i>Customer Name</i>
<i>Distribution :</i>	Shenzhen BALUN Technology Co., Ltd.

<i>Issue</i>	<i>Date</i>	<i>Modifications</i>
A	8/7/2013	Initial release

Page: 2/8



This document shall not be reproduced, except in full or in part, without the written approval of SATIMO.
The information contained herein is to be used only for the purpose for which it is submitted and is not to be released in whole or part without written approval of SATIMO.



**TABLE OF CONTENTS**

1	Introduction.....	4
2	Device Under TEst.....	4
3	Product Description	4
3.1	General Information	4
4	Measurement Method	4
4.1	Return Loss Requirements	5
4.2	Reference Dipole Calibration	5
5	Measurement Uncertainty.....	5
5.1	Return Loss	5
5.2	Validation Measurement	5
6	Calibration Measurement Results	6
6.1	Return Loss	6
6.2	Validation measurement	6
7	List of Equipment	8

Page: 3/8



*This document shall not be reproduced, except in full or in part, without the written approval of SATIMO.
The information contained herein is to be used only for the purpose for which it is submitted and is not to
be released in whole or part without written approval of SATIMO.*



1 INTRODUCTION

This document contains a summary of the requirements set forth by the ANSI C63.19 standard for reference dipoles used for HAC measurement system validations and the measurements that were performed to verify that the product complies with the fore mentioned standards.

2 DEVICE UNDER TEST

Device Under Test	
Device Type	COMOHAC 1700-2000 MHz REFERENCE DIPOLE
Manufacturer	Satimo
Model	SIDB1900
Serial Number	SN 18/12 DHB46
Product Condition (new / used)	New

A yearly calibration interval is recommended.

3 PRODUCT DESCRIPTION

3.1 GENERAL INFORMATION

Satimo's COMOHAC Validation Dipoles are built in accordance to the ANSI C63.19 standard. The product is designed for use with the COMOHAC system only.



Figure 1 – Satimo COMOHAC Validation Dipole

4 MEASUREMENT METHOD

The ANSI C63.19 standard outlines the requirements for reference dipoles to be used for system validation measurements. The following measurements were performed to verify that the product complies with the fore mentioned standard.

Page: 4/8



4.1 RETURN LOSS REQUIREMENTS

The dipole used for HAC system validation measurements and checks must have a return loss of -10 dB or better. The return loss measurement shall be performed in free space.

4.2 REFERENCE DIPOLE CALIBRATION

The IEEE ANSI C63-19 standard states that the dipole used for validation measurements and checks must be scanned with the E and H field probe, with the dipole 10 mm below the probe. The E and H field strength plots are compared to the simulation results obtained by SATIMO.

5 MEASUREMENT UNCERTAINTY

All uncertainties listed below represent an expanded uncertainty expressed at approximately the 95% confidence level using a coverage factor of k=2, traceable to the Internationally Accepted Guides to Measurement Uncertainty.

5.1 RETURN LOSS

The following uncertainties apply to the return loss measurement:

Frequency band	Expanded Uncertainty on Gain
400-6000MHz	0.1 dB

5.2 VALIDATION MEASUREMENT

The guideline outlined in the IEEE ANSI C63.19 standard was followed to generate the measurement uncertainty for validation measurements.

Uncertainty analysis of the probe calibration in waveguide					
ERROR SOURCES	Uncertainty value (%)	Probability Distribution	Divisor	Uncertainty (dB)	Standard Uncertainty (%)
RF reflections	0.1	R	$\sqrt{3}$	0.06	
Field probe conv. Factor	0.4	R	$\sqrt{3}$	0.23	
Field probe anisotropy	0.25	R	$\sqrt{3}$	0.14	
Positioning accuracy	0.2	R	$\sqrt{3}$	0.12	
Probe cable placement	0.1	R	$\sqrt{3}$	0.06	
System repeatability	0.2	R	$\sqrt{3}$	0.12	
EUT repeatability	0.4	N	1	0.40	
Combined standard uncertainty				0.52	
Expanded uncertainty 95 % confidence level k = 2				1.00	13.0



6 CALIBRATION MEASUREMENT RESULTS

6.1 RETURN LOSS

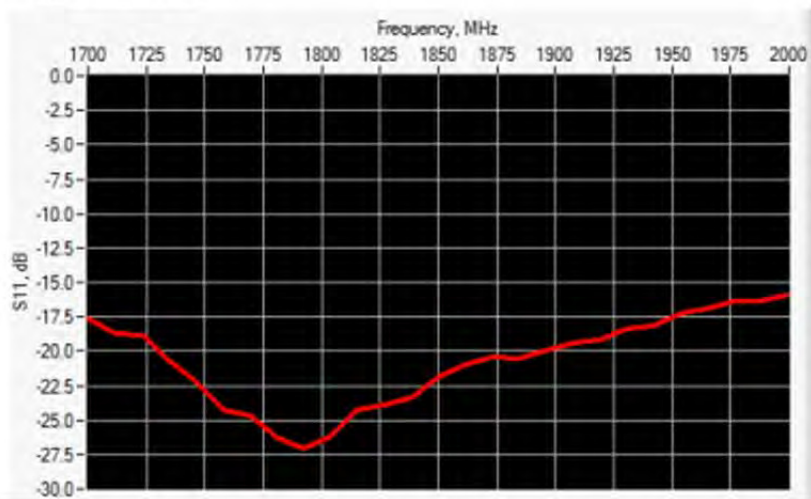

Frequency (MHz)	Worst Case Return Loss (dB)	Requirement (dB)
1700-2000 MHz	-16.31	-10

6.2 VALIDATION MEASUREMENT

The IEEE ANSI C63.19 standard states that the system validation measurements must be performed using a reference dipole meeting the fore mentioned return loss requirements. The system validations measurement results are then compared to SATIMO's simulated results.

Measurement Condition

Software Version	OpenHAC V2
HAC positioning ruler	SN 42/09 TABH12
E-Field probe	SN 08/11 EPH28
H-Field probe	SN 31/10 HPH38
Distance between dipole and sensor center	10 mm
E-field scan size	X=150mm/Y=20mm
H-field scan size	X=40mm/Y=20mm
Scan resolution	dx=5mm/dy=5mm
Frequency	1900 MHz
Input power	20 dBm
Lab Temperature	21°C
Lab Humidity	45%



Measurement Result

	Measured	Internal Requirement
E field (V/m)	149.90	153.4
H field (A/m)	0.45	0.445

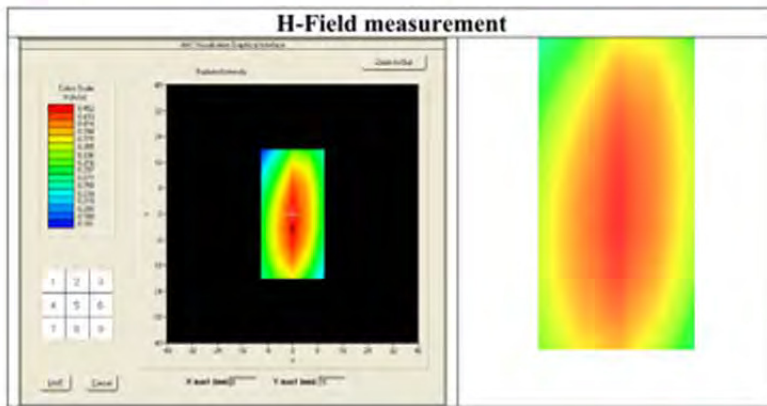
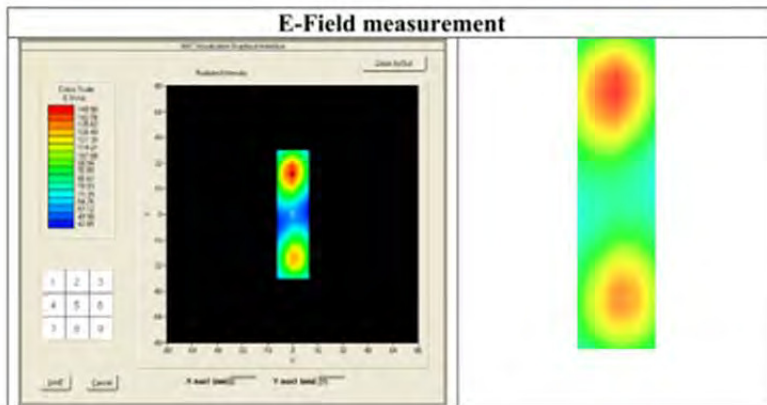

7 LIST OF EQUIPMENT

Equipment Summary Sheet				
Equipment Description	Manufacturer / Model	Identification No.	Current Calibration Date	Next Calibration Date
HAC positioning ruler	Satimo	TABH12 SN 42/09	Validated. No cal required.	Validated. No cal required.
COMOHAC Test Bench	Version 2	NA	Validated. No cal required.	Validated. No cal required.
Network Analyzer	Rhode & Schwarz ZVA	SN100132	02/2013	02/2016
Reference Probe	Satimo	EPH28 SN 08/11	Characterized prior to test. No cal required.	Characterized prior to test. No cal required.
Reference Probe	Satimo	HPH38 SN31/10	Characterized prior to test. No cal required.	Characterized prior to test. No cal required.
Multimeter	Keithley 2000	1188656	11/2010	11/2013
Signal Generator	Agilent E4438C	MY49070581	12/2010	12/2013
Amplifier	Aethercomm	SN 046	Characterized prior to test. No cal required.	Characterized prior to test. No cal required.
Power Meter	HP E4418A	US38261498	11/2010	11/2013
Power Sensor	HP ECP-E26A	US37181460	11/2010	11/2013
Directional Coupler	Narda 4216-20	01386	Characterized prior to test. No cal required.	Characterized prior to test. No cal required.
Temperature and Humidity Sensor	Control Company	11-661-9	3/2012	3/2014

Page: 8/8



This document shall not be reproduced, except in full or in part, without the written approval of SATIMO. The information contained herein is to be used only for the purpose for which it is submitted and is not to be released in whole or part without written approval of SATIMO.



--END OF REPORT--