

SYLVANIA

BLUETOOTH SPEAKER

INSTRUCTION MANUAL

MODEL: SP711



Wireless
Bluetooth



Hi-Fi Speaker



Long lasting
rechargeable battery

Please read the instruction manual
carefully before using

SYLVANIA is a registered trademark of OSRAM Sylvania Inc. used under license.

BLUETOOTH SPEAKER

Warnings:

Do not place the system in the high-temp and humidity environment. Prevent it from raining or rough handling and strong shock.

In order to avoid electric shock and other accidents. Do not open the top side panel cover for repair without any professional guidance. In case fragments or other liquids is accidentally sprinkled inside the cabinet, please switch off the power immediately, if the system needs repair, please go to the professional maintenance for help. Switch off the power and pull off the plug from the power switch when the system is not on work.

Keep it safe from water drops or splashing water, and no liquid container allowed to be put on its top side. Do not keep it close to the fire.

Warning: Changes or modifications to this unit not expressly approved by the party responsible for compliance could void the user's authority to operate the equipment.

Note: This equipment has been tested and found to comply with the limits for a Class B digital device, pursuant to Part 15 of the FCC Rules. These limits are designed to provide reasonable protection against harmful interference in a residential installation. This equipment generates, uses and can radiate radio frequency energy and, if not installed and used in accordance with the instructions, may cause harmful interference to radio communications. However, there is no guarantee that interference will not occur in a particular installation. If this equipment does cause harmful interference to radio or television reception, which can be determined by turning the equipment off and on, the user is encouraged to try to correct the interference by one or more of the following measures:

- Reorient or relocate the receiving antenna.
- Increase the separation between the equipment and receiver.
- Connect the equipment into an outlet on a circuit different from that to which the receiver is connected.
- Consult the dealer or an experienced radio/TV technician for help.

This equipment complies with FCC radiation exposure limits set forth for an uncontrolled environment. This equipment should be installed and operated with minimum distance 20cm between the radiator & your body.

BLUETOOTH SPEAKER

PANEL FUNCTIONS:

The panel in this manual is just for reference, take real object as standard.

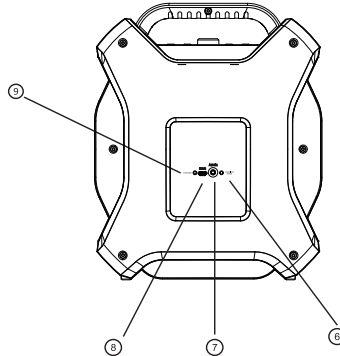
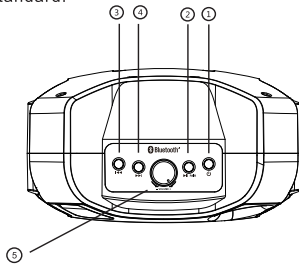

- ① ON/OFF: Press and hold for three seconds to turn on/ off the unit. Short press to turn on and off the blue LED light.
- ② **▶**: PLAY/PAIR: Press and hold it for three seconds, it can disconnect the bluetooth and go into pairing mode.
- ③ **⏮**: Press once is for previous track.
- ④ **⏭**: Press once is for NEXT play to the track
- ⑤ Turning from left to right - Volume + is volume increase
- ⑥ Working mode LED: Green LED on is for line mode. Blue LED is solid on for bluetooth mode, the blue LED will be flashing in the pairing mode.
- ⑦ AUX: 3.5 mm line in jack for connecting with audio cable (not included)
- ⑧ DC5v: 3.5mm recharging jack. connecting with USB charging wire.
- ⑨ Charging LED: the red LED is on during charging, the red LED will turn off when the battery is charging completely.

Bluetooth operation:

Power on the unit, it will go into the Bluetooth model with a tone and blue LED will be flashing slowly, search the Bluetooth name SYLVANIA SP711 from your Bluetooth device, when this Bluetooth name appears on your device, please tap to connect it, it will have tone coming out after connected successfully. Once connected you can press PLAY on your Bluetooth device or you can press the play button on the speaker. Once the music is playing, you can control it from the control buttons of the speaker. Depending on which device you are trying to connect the speaker, it may be necessary to enter a passcode. Enter passcode "0000" if prompted by the device.

AUX input operation:

Insert the 3.5mm cable (not included) to the product, it will go into the AUX mode and the green led will be on. You can enjoy the music from the cell phone or multi media player.

Turn the volume knob or press the volume from your device to adjust the volume in the desired level.

NOTE:

When the AUX cable is inserted, this product will change to the AUX mode and disconnected bluetooth mode automatically. Please pull out this AUX cable, if you want to change back bluetooth mode.

BLUETOOTH SPEAKER

Trouble shooting:

No function light & No sound

1. Possible problem: Plug is not well connected.

Solution: Insert the plug into electric outlet

Function light on but no sound

1. Possible problem: Cable misconnected

Solution: Turn off the power, check the input jack to ensure proper audio signal is connected to relevant input jack

2. Possible problem: Audio signal is not transmitted to speakers

Solution: Check all the speakers if there is audio signal output

If the problem exists after checking related procedures above, please refer to the appointed service agent professional technician to fix it. Do not attempt to company assumes no responsibility.

Product equipment list:

1. Portable Bluetooth Speaker unit 1PC
2. USB Charging cable 1PC

Specifications:

Output power: 3W

Input power: DC5V,500mAh

Speaker unit: 4 INCHES

Frequency response: 80Hz-20KHz

Built in rechargeable Battery: 3.7V/1200mAh

LIMITED PRODUCT WARRANTY

This quality product is warranted to be free from manufacturer's defects in material and workman-ship, provided that the unit is used under the normal operating conditions intended by the manufacturer.

Should you have any problem with this product, please and it is highly recommended to visit our website at www.curtisint.com before you take any other steps as we have additional copies of instruction manuals, operating manuals and trouble shooting tips on our website which gives you the answer on most of the questions you could have in operating the unit.

TERMS OF WARRANTY

C.I. Service Dept. warrants this product to be free from defects in materials and workmanship for 90 days on parts and 90 days on labor. If you originally purchased your product more than 90 days ago, a repair fee may apply.

Nothing within this warranty shall imply that C.I. will be responsible or liable for any damage to any items placed in this product, whether due to any defect of the product, or its use, whether proper or improper.

EXCLUSIONS

Save as herein provided, C.I. Service Dept. (Canada) or C.I. Service Dept. (USA), there are no other warranties, conditions, representations or guarantees, express or implied, made or intended by C.I. or its authorized distributors and all other warranties, conditions, representations or guarantees, including any warranties, conditions, representations or guarantees under any Sale of Goods Act or like legislation or statute is hereby expressly excluded. Save as herein provided, C.I. Service Dept. (Canada) or C.I. Service Dept. (USA), shall not be responsible for any damages to persons or property, including the unit itself, howsoever caused or any consequential damages arising from the malfunction of the unit and by the purchase of the unit, the purchaser does hereby agree to indemnify and save harmless C.I. from any claim for damages to persons or property caused by the unit.

TO OBTAIN REPAIRS UNDER THE TERMS OF THIS WARRANTY

1. The original purchaser must present a copy of the original bill of sale and the service warranty card.
2. Any alterations, abuse, misuse, battery corrosion or accidental damage voids the warranty.
3. The warranty does not cover cabinets and accessories.
4. No warranty or insurance contained or set out shall apply when damage or repair is caused by power failure; damage in transit or when moving the unit; improper power supply; use for commercial or industrial purposes; service calls resulting in customer education, etc.
5. The defective product should be mailed to:

Canada
C.I. Service Dept.
315 Attwell Drive
Toronto, ON
M9W 5C1

U.S.A
Curtis International Ltd
c/o Lotus International Company
6880 Commerce Blvd.
Canton MI 48187
U.S.A.

For service assistance and product information, please call: 1-800-968-9853.

If mailing the product, the freight must be prepaid and a money order for \$7.00 should be included to cover the cost of insurance and the return of the product.

6. C.I. reserves the right to repair or replace the parts which have become defective.

To begin the **warranty repair process**, please note that you **MUST** obtain a **return authorization number** prior to returning your product for warranty based support. This can be placed under the 1-800-968-9853 contact line.

Model No. _____ Date Purchased _____ Serial No. _____