



TEST REPORT

Report Reference No......: **CTL1512213754-WF**

Compiled by
(position+printed name+signature)...: File administrators Jacky Chen

Jacky Chen

Name of the organization performing the tests
(position+printed name+signature)...: Test Engineer Happy Guo

Happy Guo

Approved by
(position+printed name+signature)...: Manager Tracy Qi

Tracy Qi

Date of issue.....: Jan. 11, 2016

Test Firm.....: **Shenzhen CTL Testing Technology Co., Ltd.**

Address.....: Floor 1-A, Baisha Technology Park, No.3011, Shahexi Road, Nanshan District, Shenzhen, China 518055

Applicant's name.....: **ION Audio, LLC**

Address.....: 200 Scenic View Drive, Cumberland, RI 02864, U.S.A.

Test specification:

Standard: **47 CFR FCC Part 15 Subpart C 15.247 & RSS 247 Issue 1, May 2015**

Master TRF.....: Dated 2011-01

Shenzhen CTL Testing Technology Co., Ltd. All rights reserved.

This publication may be reproduced in whole or in part for non-commercial purposes as long as the Shenzhen CTL Testing Technology Co., Ltd. is acknowledged as copyright owner and source of the material. Shenzhen CTL Testing Technology Co., Ltd. takes no responsibility for and will not assume liability for damages resulting from the reader's interpretation of the reproduced material due to its placement and context.

Test item description: **All-In-One Bluetooth Loudspeaker**

FCC ID.....: **2AB3E-IPA69**

IC: **10541A-IPA69**

Trade Mark: ION

Model/Type reference.....: Total PA Plus, iPA69

Work frequency: 2402~2480MHz

Version.....: V2.1+EDR

Type of modulation: FHSS

Data Rate.....: 1Mbps(GFSK), 2Mbps(Pi/4 DQPSK), 3Mbps(8DPSK)

Antenna Gain: 0 dBi

Antenna type: Internal

Result.....: **Positive**

TEST REPORT

Test Report No. :	CTL1512213754-WF	Jan. 11, 2016
		Date of issue

Equipment under Test : All-In-One Bluetooth Loudspeaker

Model /Type : Total PA Plus

Listed Models : iPA69

Difference Description : Only the color and model's name is different

Applicant : **ION Audio, LLC**

Address : 200 Scenic View Drive, Cumberland, RI 02864, U.S.A.

Manufacturer : **ION Audio, LLC**

Address : 200 Scenic View Drive, Cumberland, RI 02864, U.S.A.

Test Result according to the standards on page 5:

Positive

The test report merely corresponds to the test sample.
It is not permitted to copy extracts of these test result without the written permission of the test laboratory.

Contents

<u>1.</u>	<u>TEST STANDARDS</u>	<u>4</u>
<u>2.</u>	<u>SUMMARY</u>	<u>5</u>
2.1.	General Remarks	5
2.2.	Equipment Under Test	5
2.3.	Short description of the Equipment under Test (EUT)	5
2.4.	EUT operation mode	5
2.5.	EUT configuration	6
2.6.	Configuration of Tested System	6
2.7.	Related Submittal(s) / Grant (s)	6
2.8.	Modifications	6
2.9.	Frequency Hopping System Requirements	6
2.10.	Mode of Operation	8
<u>3.</u>	<u>TEST ENVIRONMENT</u>	<u>9</u>
3.1.	Address of the test laboratory	9
3.2.	Test Facility	9
3.3.	Environmental conditions	9
3.4.	Statement of the measurement uncertainty	9
3.5.	Test Description	10
3.6.	Equipments Used during the Test	11
<u>4.</u>	<u>TEST CONDITIONS AND RESULTS</u>	<u>12</u>
4.1.	AC Power Conducted Emission	12
4.2.	Radiated Emission and Band Edge	15
4.3.	Maximum Peak Output Power	22
4.4.	20dB Bandwidth and 99% Bandwidth	24
4.5.	Frequency Separation	29
4.6.	Number of hopping frequency	31
4.7.	Time Of Occupancy(Dwell Time)	38
4.8.	Spurious RF Conducted Emissions and bandedge	40
4.9.	Antenna Requirement	50
4.10.	RF Exposure	51
<u>5.</u>	<u>TEST SETUP PHOTOS OF THE EUT</u>	<u>52</u>
<u>6.</u>	<u>EXTERNAL AND INTERNAL PHOTOS OF THE EUT</u>	<u>54</u>

1. TEST STANDARDS

The tests were performed according to following standards:

[FCC Rules Part 15.247](#): Frequency Hopping, Direct Spread Spectrum and Hybrid Systems that are in operation within the bands of 902-928 MHz, 2400-2483.5 MHz, and 5725-5850 MHz

[RSS-247-Issue 1](#): Digital Transmission Systems (DTSs), Frequency Hopping Systems (FHSs) and Licence-Exempt Local Area Network (LE-LAN) Devices.

[RSS-Gen Issue 4](#): General Requirements for Compliance of Radio Apparatus

[ANSI C63.10:2013](#) : American National Standard for Testing Unlicensed Wireless Devices

[ANSI C63.4: 2014](#): –American National Standard for Methods of Measurement of Radio-Noise Emissions from Low-Voltage Electrical and Electronic Equipment in the Range of 9 kHz to 40GHz



2. SUMMARY

2.1. General Remarks

Date of receipt of test sample	:	Dec. 21, 2015
Testing commenced on	:	Dec. 21, 2015
Testing concluded on	:	Jan. 09, 2016

2.2. Equipment Under Test

Power supply system utilised

Power supply voltage	:	<input checked="" type="radio"/> 120V / 60 Hz	<input type="radio"/> 115V / 60Hz
		<input type="radio"/> 12 V DC	<input type="radio"/> 24 V DC
		<input type="radio"/> Other (specified in blank below)	

2.3. Short description of the Equipment under Test (EUT)

Product Name:	All-In-One Bluetooth Loudspeaker
Model/Type reference:	Total PA Plus
Power supply:	AC 120V/60Hz
Bluetooth 2.1+EDR	
Modulation:	1Mbps(GFSK), 2Mbps($\pi/4$ DQPSK), 3Mbps(8DPSK)
Operation frequency:	2402MHz~2480MHz
Channel number:	79
Channel separation:	1MHz
Antenna type:	PCB Antenna
Antenna gain:	0dBi

2.4. EUT operation mode

The EUT has been tested under typical operating condition. The Applicant provides communication tools software to control the EUT for staying in continuous transmitting and receiving mode for testing. There are 79 channels of EUT, and the test carried out at the lowest channel, middle channel and highest channel.

Frequency Range:	2402-2480MHz
Channel number:	79 channels
Modulation type:	GFSK, $\pi/4$ -DQPSK, 8-DPSK
Antenna:	PCB antenna

Test Channel	Test Frequency
Low Channel	2402 MHz
Middle Channel	2441 MHz
High Channel	2480 MHz

2.5. EUT configuration

The following peripheral devices and interface cables were connected during the measurement:

- - supplied by the manufacturer
- - supplied by the lab

● Notebook PC(FCC DOC Approval)	Manufacturer :	DELL
	Model No. :	PP18L

2.6. Configuration of Tested System

Fig. 2-1 Configuration of Tested System



Table 2-1 Equipment Used in Tested System

2.7. Related Submittal(s) / Grant (s)

This submittal(s) (test report) is intended for **FCC ID: 2AB3E-IPA69** and **IC: 10541A-IPA69** filing to comply with Section 15.247 of the FCC Part 15, Subpart C Rules and RSS 247 Issue 1.

2.8. Modifications

No modifications were implemented to meet testing criteria.

2.9. Frequency Hopping System Requirements

Standard Applicable

According to FCC Part 15.247(a)(1), The system shall hop to channel frequencies that are selected at the system hopping rate from a pseudo randomly ordered list of hopping frequencies. Each frequency must be used equally on the average by each transmitter. The system receivers shall have input bandwidths that match the hopping channel bandwidths of their corresponding transmitters and shall shift frequencies in synchronization with the transmitted signals.

(g) Frequency hopping spread spectrum systems are not required to employ all available hopping channels during each transmission. However, the system, consisting of both the transmitter and the receiver, must be designed to comply with all of the regulations in this section should the transmitter be presented with a continuous data (or information) stream. In addition, a system employing short transmission bursts must comply with the definition of a frequency hopping system and must distribute its transmissions over the minimum number of hopping channels specified in this section.

(h) The incorporation of intelligence within a frequency hopping spread spectrum system that permits the system to recognize other users within the spectrum band so that it individually and independently chooses

and adapts its hopsets to avoid hopping on occupied channels is permitted. The coordination of frequency hopping systems in any other manner for the express purpose of avoiding the simultaneous occupancy of individual hopping frequencies by multiple transmitters is not permitted.

EUT Pseudorandom Frequency Hopping Sequence

The pseudorandom sequence may be generated in a nine-stage shift register whose 5th and 9th stage outputs are added in a modulo-two addition stage, and the result is fed back to the input of the first stage. The sequence begins with the first ONE of 9 consecutive ONES; i.e. the shift register is initialized with nine ones.

Number of shift register stages: 9
 Length of pseudo-random sequence: 29-1=511bits
 Longest sequence of zeros: 8(non-inverted signal)

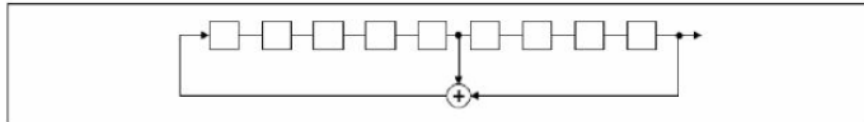

Linear Feedback Shift Register for Generation of the PRBS sequence

The frequencies allocated for the Bluetooth Module is $F(\text{MHz})=2402+1*n$ ($0 < n <= 78$). The lowest, middle, highest channel numbers of the Bluetooth Module used and tested in this report are separately 0 (2402MHz), 39 (2441MHz) and 78 (2480MHz).

Each frequency used equally on the average by each transmitter. The system receiver have input bandwidths that match the hopping channel bandwidths of their corresponding transmitters and shift frequencies in synchronization with the transmitted signals.

The selection scheme chooses a segment of 32 hop frequencies spanning about 64 MHz and visits these hops in a pseudo-random order. Next, a different 32-hop segment is chosen, etc. In the page, master page response, slave page response, page scan, inquiry, inquiry response and inquiry scan hopping sequences, the same 32-hop segment is used all the time (the segment is selected by the address; different devices will have different paging segments).

When the basic channel hopping sequence is selected, the output constitutes a pseudo-random sequence that slides through the 79 hops.

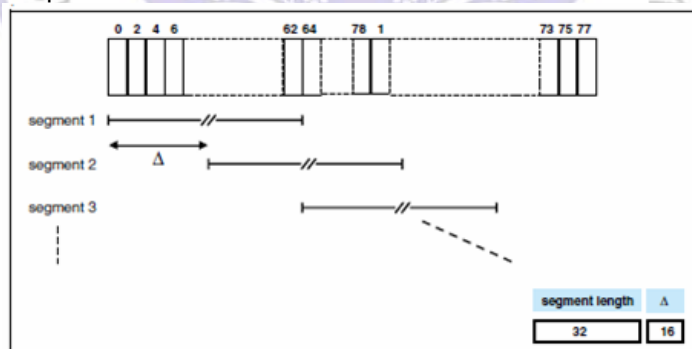

Hop selection scheme in CONNECTION state.

Channels list:

Channel	Frequency (MHz)	Channel	Frequency (MHz)	Channel	Frequency (MHz)
00	2402	27	2429	54	2456
01	2403	28	2430	55	2457
02	2404	29	2431	56	2458
03	2405	30	2432	57	2459
04	2406	31	2433	58	2460
05	2407	32	2434	59	2461
06	2408	33	2435	60	2462
07	2409	34	2436	61	2463
08	2410	35	2437	62	2464

09	2411	36	2438	63	2465
10	2412	37	2439	64	2466
11	2413	38	2440	65	2467
12	2414	39	2441	66	2468
13	2415	40	2442	67	2469
14	2416	41	2443	68	2470
15	2417	42	2444	69	2471
16	2418	43	2445	70	2472
17	2419	44	2446	71	2473
18	2420	45	2447	72	2474
19	2421	46	2448	73	2475
20	2422	47	2449	74	2476
21	2423	48	2450	75	2477
22	2424	49	2451	76	2478
23	2425	50	2452	77	2479
24	2426	51	2453	78	2480
25	2427	52	2454		
26	2428	53	2455		

The pseudorandom frequency hopping sequence sample:

42,41,66,4,78,59,55,48,54,46,52,78,41,26,24,34,39,32,51,18,25,9,12,73,70,58,54,6,66,4,32,67,60,16,3,78,78,76,47,45,47,49,14,34, etc.

Frequency Hopping System

This transmitter device is frequency hopping device, and complies with FCC part 15.247 rule.

This device uses Bluetooth radio which operates in 2400-2483.5 MHz band. Bluetooth uses a radio technology called frequency-hopping spread spectrum, which chops up the data being sent and transmits chunks of it on up to 79 channels (1 MHz separation; from 2402 to 2480 MHz) in the range 2,400-2,483.5 MHz. The transmitter switches hop frequencies 1,600 times per second to assure a high degree of data security. All Bluetooth devices participating in a given piconet are synchronized to the frequency-hopping channel for the piconet. The frequency hopping sequence is determined by the master's device address and the phase of the hopping sequence (the frequency to hop at a specific time) is determined by the master's internal clock. Therefore, all slaves in a piconet must know the master's device address and must synchronize their clocks with the master's clock.

Adaptive Frequency Hopping (AFH) was introduced in the Bluetooth specification to provide an effective way for a Bluetooth radio to counteract normal interference. AFH identifies "bad" channels, where either other wireless devices are interfering with the Bluetooth signal or the Bluetooth signal is interfering with another device. The AFH-enabled Bluetooth device will then communicate with other devices within its piconet to share details of any identified bad channels. The devices will then switch to alternative available "good" channels, away from the areas of interference, thus having no impact on the bandwidth used.

This device was tested with an bluetooth system receiver to check that the device maintained hopping synchronization, and the device complied with these requirements for DA 00-705 and FCC Part 15.247 rule.

2.10. Mode of Operation

CTL has verified the construction and function in typical operation. All the test modes were carried out with the EUT in TX operation, Worse case is shown in this test report and defined as:

Test Mode
Mode 1: Transmitter-1Mbps(GFSK_DH5) DH5
Mode 2: Transmitter-2Mbps(Pi/4 DQPSK_DH5) 2DH5
Mode 3: Transmitter-3Mbps(8DPSK_DH5) 3DH5

3. TEST ENVIRONMENT

3.1. Address of the test laboratory

Shenzhen CTL Testing Technology Co., Ltd.
Floor 1-A, Baisha Technology Park, No.3011, Shaheji Road, Nanshan District, Shenzhen, China 518055

The sites are constructed in conformance with the requirements of ANSI C63.7, ANSI C63.10 (2013) and CISPR Publication 22.

3.2. Test Facility

The test facility is recognized, certified, or accredited by the following organizations:

IC Registration No.: 9618B

The 3m alternate test site of Shenzhen CTL Testing Technology Co., Ltd. EMC Laboratory has been registered by Certification and Engineer Bureau of Industry Canada for the performance of with Registration No.: 9618B on November 13, 2013.

FCC-Registration No.: 970318

Shenzhen CTL Testing Technology Co., Ltd. EMC Laboratory has been registered and fully described in a report filed with the (FCC) Federal Communications Commission. The acceptance letter from the FCC is maintained in our files. Registration 970318, December 19, 2013.

3.3. Environmental conditions

During the measurement the environmental conditions were within the listed ranges:

Temperature:	<u>15-35 ° C</u>
Humidity:	<u>30-60 %</u>
Atmospheric pressure:	<u>950-1050mbar</u>

3.4. Statement of the measurement uncertainty

The data and results referenced in this document are true and accurate. The reader is cautioned that there may be errors within the calibration limits of the equipment and facilities. The measurement uncertainty was calculated for all measurements listed in this test report acc. to CISPR 16 - 4 „Specification for radio disturbance and immunity measuring apparatus and methods – Part 4: Uncertainty in EMC Measurements“ and is documented in the Shenzhen CTL Testing Technology Co., Ltd. quality system acc. to DIN EN ISO/IEC 17025. Furthermore, component and process variability of devices similar to that tested may result in additional deviation. The manufacturer has the sole responsibility of continued compliance of the device.

Hereafter the best measurement capability for CTL laboratory is reported:

Test	Range	Measurement Uncertainty	Notes
Radiated Emission	30~1000MHz	4.10dB	(1)
Radiated Emission	Above 1GHz	4.32dB	(1)
Conducted Disturbance	0.15~30MHz	3.20dB	(1)

- (1) This uncertainty represents an expanded uncertainty expressed at approximately the 95% confidence level using a coverage factor of k=2.

3.5. Test Description

FCC Part Section	RSS Section(s)	Test Description	Test Result
15.207 (a)	RSS-GEN 8.8	AC Power Conducted Emission	PASS
2.1049	RSS-GEN 4.6	Occupied Band width	PASS
15.205, 15.209	RSS-GEN 8.9/7	Spurious Emission	PASS
15.247 (b)(1)	RSS-247 5.4.2	Maximum Peak Output Power	PASS
15.205, 15.209	RSS-GEN 8.9/7	Radiated Emissions	PASS
2.1051, 15.247 (d)	RSS-247 5.5	Band Edge /Conducted Spurious Emission	PASS
15.247 (a)(1)	RSS-247 5.1.2	Frequency Separation	PASS
15.247 (a)(1)(iii)	RSS-247 5.1.4	Number of hopping frequency	PASS
15.247 (a)(1)(iii)	RSS-247 5.1.4	Time of Occupancy	PASS

Remark: The measurement uncertainty is not included in the test result.



3.6. Equipments Used during the Test

Test Equipment	Manufacturer	Model No.	Serial No.	Calibration Date	Calibration Due Date
LISN	R&S	ENV216	3560.6550.12	2015/06/02	2016/06/01
LISN	R&S	ESH2-Z5	860014/010	2015/06/02	2016/06/01
Power Meter	Anritsu	ML2487B	110553	2015/06/02	2016/06/01
Power Sensor	Anritsu	MA2411B	100345	2015/05/21	2016/05/20
Bilog Antenna	Sunol Sciences Corp.	JB1	A061713	2015/06/02	2016/06/01
EMI Test Receiver	R&S	ESCI	103710	2015/06/02	2016/06/01
Spectrum Analyzer	Agilent	E4407B	MY41440676	2015/05/21	2016/05/20
Spectrum Analyzer	Agilent	N9020A	US46220290	2015/12/10	2016/12/09
Controller	EM Electronics	Controller EM 1000	N/A	2015/05/21	2016/05/20
Horn Antenna	Sunol Sciences Corp.	DRH-118	A062013	2015/05/19	2016/05/18
Active Loop Antenna	SCHWARZBECK	FMZB1519	1519-037	2015/05/19	2016/05/18
Amplifier	Agilent	8349B	3008A02306	2015/05/19	2016/05/18
Amplifier	Agilent	8447D	2944A10176	2015/05/19	2016/05/18
Temperature/Humidity Meter	Gangxing	CTH-608	02	2015/05/20	2016/05/19
High-Pass Filter	K&L	9SH10-2700/X12750-O/O	N/A	2015/05/20	2016/05/19
High-Pass Filter	K&L	41H10-1375/U12750-O/O	N/A	2015/05/20	2016/05/19
Coaxial Cables	HUBER+SUHNER	SUCOFLEX 104PEA-10M	10m	2015/06/02	2016/06/01
Coaxial Cables	HUBER+SUHNER	SUCOFLEX 104PEA-3M	3m	2015/06/02	2016/06/01
Coaxial Cables	HUBER+SUHNER	SUCOFLEX 104PEA-3M	3m	2015/06/02	2016/06/01
RF Cable	Megalon	RF-A303	N/A	2015/06/02	2016/06/01

The calibration interval was one year

4. TEST CONDITIONS AND RESULTS

4.1. AC Power Conducted Emission

TEST CONFIGURATION

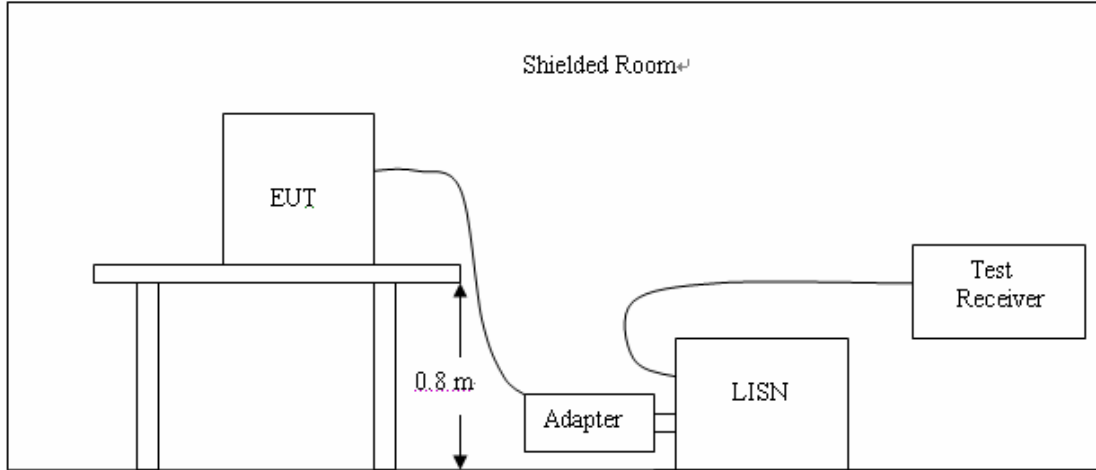

TEST PROCEDURE

- 1 The equipment was set up as per the test configuration to simulate typical actual usage per the user's manual. The EUT is a tabletop system, a wooden table with a height of 0.8 meters is used and is placed on the ground plane as per ANSI C63.10-2013.
- 2 Support equipment, if needed, was placed as per ANSI C63.10-2013
- 3 All I/O cables were positioned to simulate typical actual usage as per ANSI C63.10-2013
- 4 The EUT received DC5V power from the adapter, the adapter received AC120V/60Hz power through a Line Impedance Stabilization Network (LISN) which supplied power source and was grounded to the ground plane.
- 5 All support equipments received AC power from a second LISN, if any.
- 6 The EUT test program was started. Emissions were measured on each current carrying line of the EUT using a spectrum Analyzer / Receiver connected to the LISN powering the EUT. The LISN has two monitoring points: Line 1 (Hot Side) and Line 2 (Neutral Side). Two scans were taken: one with Line 1 connected to Analyzer / Receiver and Line 2 connected to a 50 ohm load; the second scan had Line 1 connected to a 50 ohm load and Line 2 connected to the Analyzer / Receiver.
- 7 Analyzer / Receiver scanned from 150 KHz to 30MHz for emissions in each of the test modes.
- 8 During the above scans, the emissions were maximized by cable manipulation.
Conducted emissions were investigated over the frequency range from 0.15MHz to 30MHz using a receiver bandwidth of 9kHz.

AC Power Conducted Emission Limit

For intentional device, according to § 15.207(a) AC Power Conducted Emission Limits is as following :

Frequency (MHz)	Maximum RF Line Voltage (dB μ V)			
	CLASS A		CLASS B	
	Q.P.	Ave.	Q.P.	Ave.
0.15 - 0.50	79	66	66-56*	56-46*
0.50 - 5.00	73	60	56	46
5.00 - 30.0	73	60	60	50

* Decreasing linearly with the logarithm of the frequency

TEST RESULTS

The 1Mbps (GFSK Modulation) is the worst case as results in the report based on the Pre-test for all modulation models.

Mode 1:

SCAN TABLE: "Voltage (9K-30M)FIN"

Short Description: 150K-30M Voltage

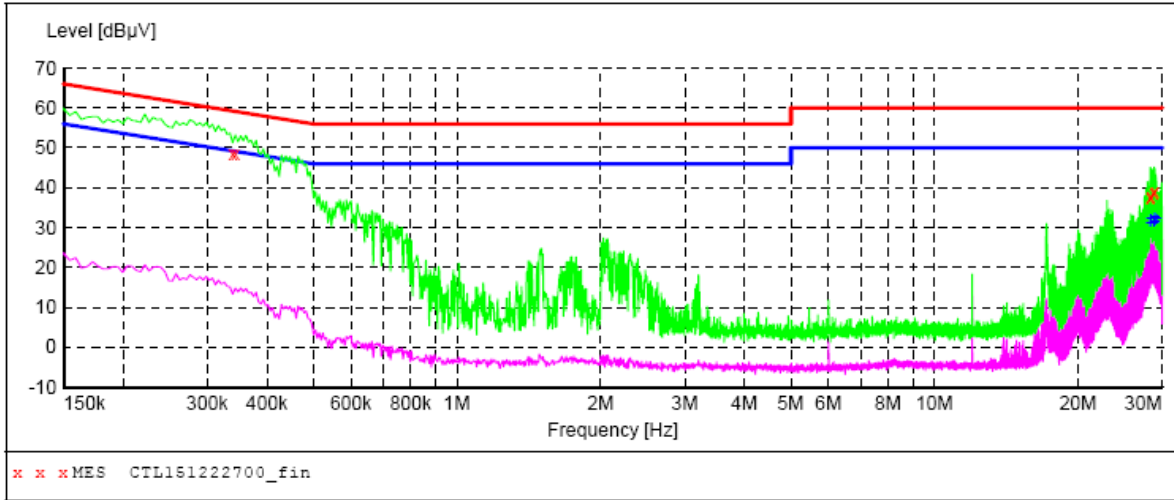

MEASUREMENT RESULT: "CTL151222700_fin"

12/22/2015 4:27PM

Frequency MHz	Level dBµV	Transd dB	Limit dBµV	Margin dB	Detector	Line	PE
0.339001	48.60	10.2	59	10.6	QP	N	GND
0.343501	48.50	10.2	59	10.6	QP	N	GND
28.338001	37.50	11.2	60	22.5	QP	N	GND
28.396501	37.80	11.2	60	22.2	QP	N	GND
28.819501	38.60	11.2	60	21.4	QP	N	GND
28.941001	39.10	11.2	60	20.9	QP	N	GND

MEASUREMENT RESULT: "CTL151222700_fin2"

12/22/2015 4:27PM

Frequency MHz	Level dBµV	Transd dB	Limit dBµV	Margin dB	Detector	Line	PE
28.338001	31.10	11.2	50	18.9	AV	N	GND
28.396501	32.30	11.2	50	17.7	AV	N	GND
28.819501	31.00	11.2	50	19.0	AV	N	GND
28.936501	32.60	11.2	50	17.4	AV	N	GND
28.999501	31.50	11.2	50	18.5	AV	N	GND
29.179501	32.40	11.2	50	17.6	AV	N	GND

SCAN TABLE: "Voltage (9K-30M)FIN"

Short Description: 150K-30M Voltage

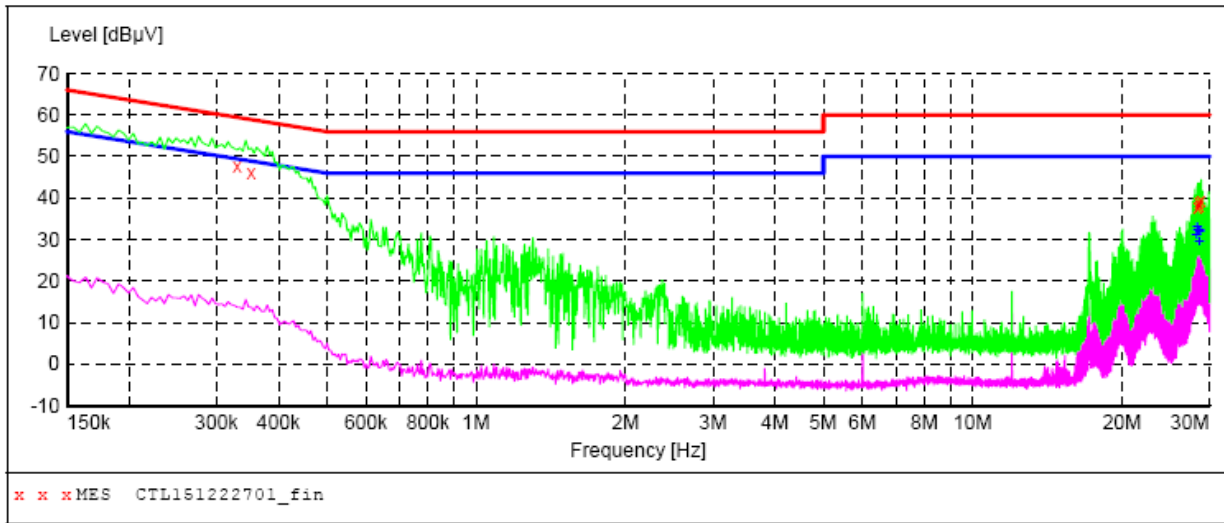

MEASUREMENT RESULT: "CTL151222701_fin"

12/22/2015 4:31PM

Frequency MHz	Level dBµV	Transd dB	Limit dBµV	Margin dB	Detector	Line	PE
0.330001	47.70	10.2	60	11.8	QP	L1	GND
0.352501	46.10	10.2	59	12.8	QP	L1	GND
28.396501	37.60	11.2	60	22.4	QP	L1	GND
28.576501	39.10	11.2	60	20.9	QP	L1	GND
28.639501	38.30	11.2	60	21.7	QP	L1	GND
28.819501	39.30	11.2	60	20.7	QP	L1	GND

MEASUREMENT RESULT: "CTL151222701_fin2"

12/22/2015 4:31PM

Frequency MHz	Level dBµV	Transd dB	Limit dBµV	Margin dB	Detector	Line	PE
28.216501	31.20	11.2	50	18.8	AV	L1	GND
28.338001	32.90	11.2	50	17.1	AV	L1	GND
28.396501	32.40	11.2	50	17.6	AV	L1	GND
28.581001	29.60	11.2	50	20.4	AV	L1	GND
28.639501	32.10	11.2	50	17.9	AV	L1	GND
28.698001	31.80	11.2	50	18.2	AV	L1	GND

4.2. Radiated Emission and Band Edge

TEST CONFIGURATION

Radiated Emission Test Set-Up
Frequency range 9KHz – 30MHz

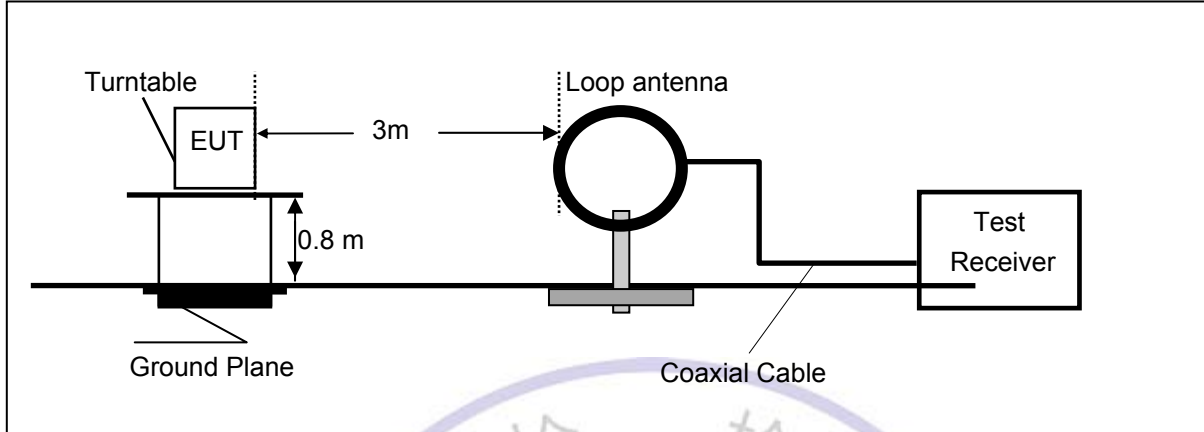

Frequency range 30MHz – 1000MHz

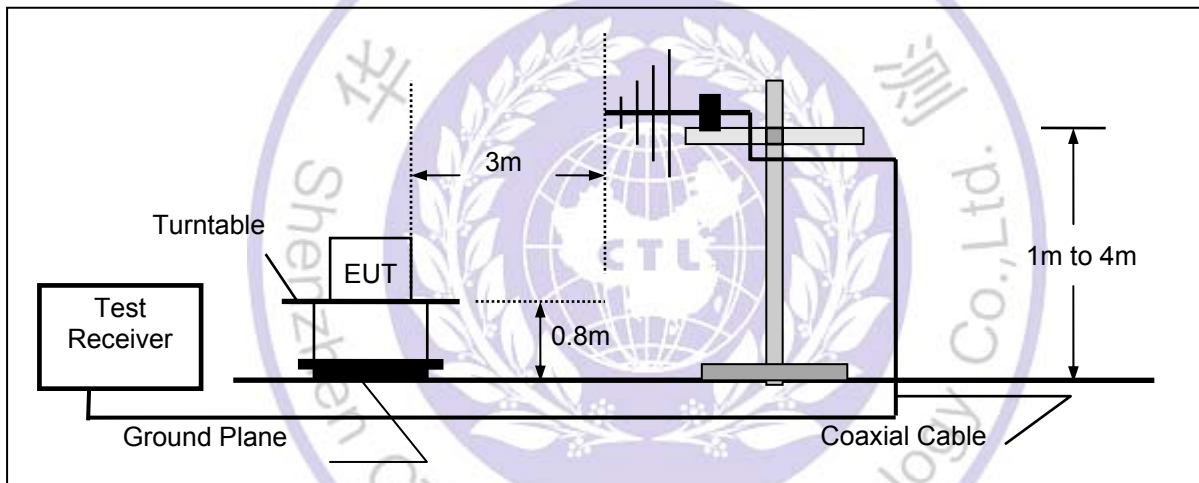

Frequency range above 1GHz-25GHz

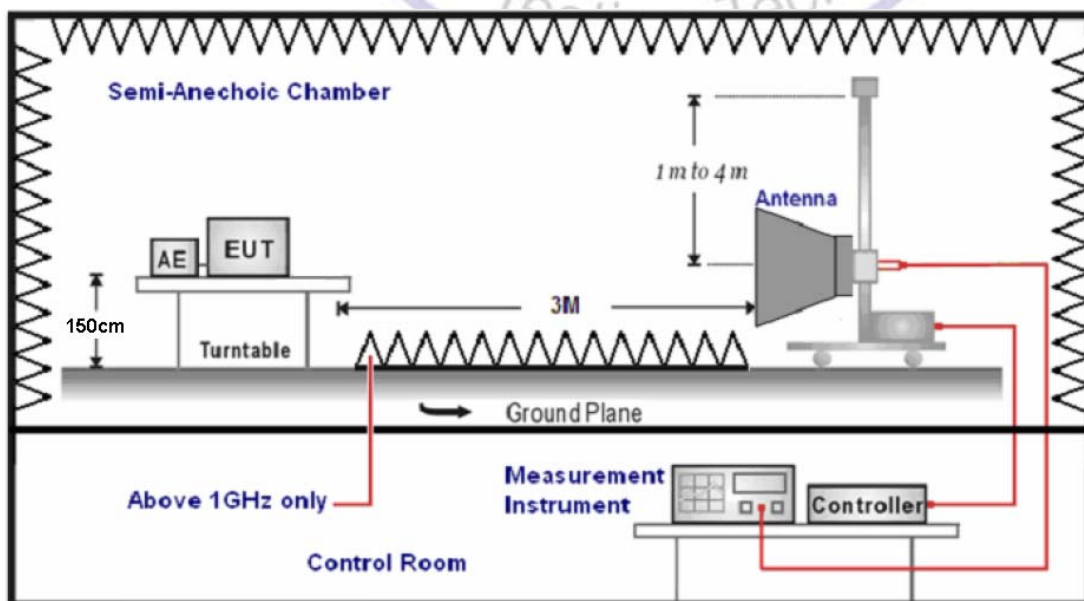

TEST PROCEDURE

- 1 The EUT is placed on a turntable, which is 0.8m above ground plane below 1GHz and 1.5m above ground plane above 1GHz.
- 2 Maximum procedure was performed by raising the receiving antenna from 1m to 4m and rotating the turn table from 0° to 360° to acquire the highest emissions from EUT
3. And also, each emission was to be maximized by changing the polarization of receiving antenna both horizontal and vertical.
4. Repeat above procedures until all frequency measurements have been completed.
5. The fundamental frequency is 2400-2483.5MHz, So the radiation emissions frequency range were tested from 9KHz to 25GHz.

Field Strength Calculation

The field strength is calculated by adding the Antenna Factor and Cable Factor and subtracting the Amplifier Gain and Duty Cycle Correction Factor(if any) from the measured reading. The basic equation with a sample calculation is as follows:

$$FS = RA + AF + CL - AG$$

Where FS = Field Strength	CL = Cable Attenuation Factor (Cable Loss)
RA = Reading Amplitude	AG = Amplifier Gain
AF = Antenna Factor	

For example

Frequency (MHz)	FS (dBμV/m)	RA (dBμV/m)	AF (dB)	CL (dB)	AG (dB)	Transd (dB)
300.00	40	58.1	12.2	1.6	31.90	-18.1

$$\text{Transd} = \text{AF} + \text{CL} - \text{AG}$$

RADIATION LIMIT

For intentional device, according to § 15.209(a), the general requirement of field strength of radiated emission from intentional radiators at a distance of 3 meters shall not exceed the following table. According to § 15.247(d), in any 100kHz bandwidth outside the frequency band in which the EUT is operating, the radio frequency power that is produced by the intentional radiator shall be at least 20dB below that in the 100kHz bandwidth within the band that contains the highest level of desired power.

Frequency (MHz)	Distance (Meters)	Radiated (dBμV/m)	Radiated (μV/m)
30-88	3	40.0	100
88-216	3	43.5	150
216-960	3	46.0	200
Above 960	3	54.0	500

TEST RESULTS

Below 1GHz:

The radiated measurement are performed the each test mode (GFSK / Pi/4 DQPSK /8DPSK) and channel (low/mid/high), the datum recorded below (GFSK mode, the middle channel) is the worst case for all the test mode and channel.

SWEEP TABLE: "test (30M-1G)"

Short Description:		Field Strength			
Start	Stop	Detector	Meas. Time	IF Bandw.	Transducer
Frequency	Frequency				
30.0 MHz	1.0 GHz	MaxPeak	300.0 ms	120 kHz	JB1

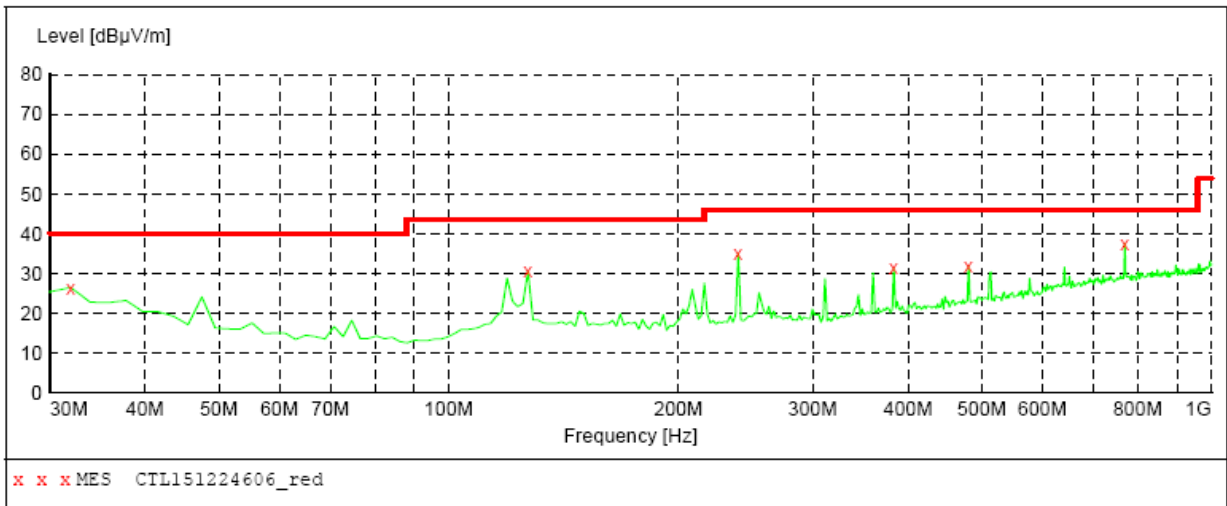

MEASUREMENT RESULT: "CTL151224606_red"

12/24/2015 9:41AM

Frequency MHz	Level dBuV/m	Transd dB	Limit dBuV/m	Margin dB	Det.	Height cm	Azimuth deg	Polarization
31.940000	26.40	19.2	40.0	13.6	---	0.0	0.00	VERTICAL
127.000000	30.50	14.6	43.5	13.0	---	0.0	0.00	VERTICAL
239.520000	35.00	13.7	46.0	11.0	---	0.0	0.00	VERTICAL
383.080000	31.30	17.7	46.0	14.7	---	0.0	0.00	VERTICAL
480.080000	31.90	20.0	46.0	14.1	---	0.0	0.00	VERTICAL
769.140000	37.50	24.4	46.0	8.5	---	0.0	0.00	VERTICAL

SWEEP TABLE: "test (30M-1G)"

Short Description:		Field Strength			
Start	Stop	Detector	Meas. Time	IF Bandw.	Transducer
30.0 MHz	1.0 GHz	MaxPeak	300.0 ms	120 kHz	JB1

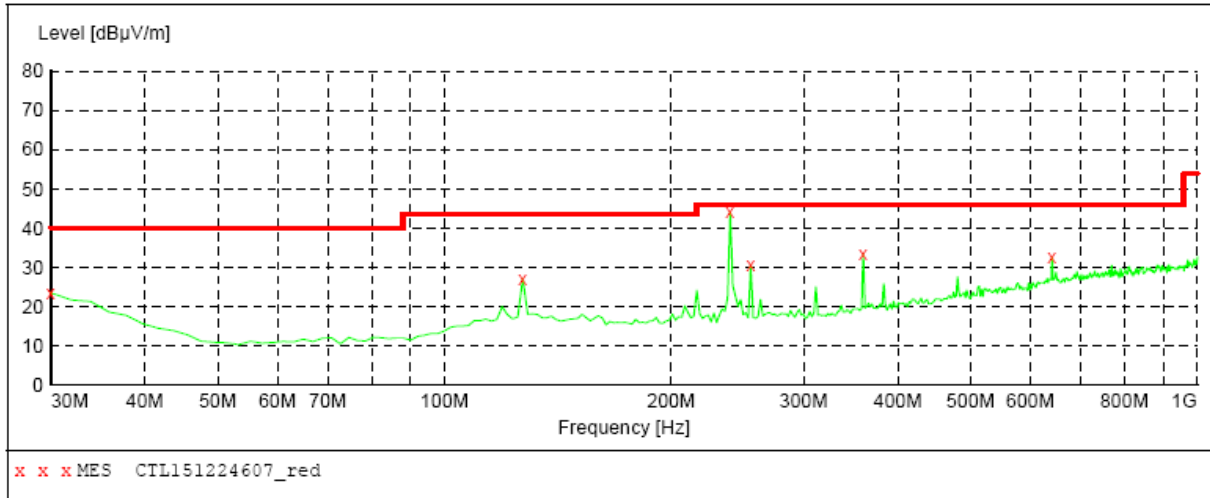

MEASUREMENT RESULT: "CTL151224607_red"

12/24/2015 9:43AM

Frequency MHz	Level dBµV/m	Transd dB	Limit dBµV/m	Margin dB	Det.	Height cm	Azimuth deg	Polarization
30.000000	23.40	20.8	40.0	16.6	---	0.0	0.00	HORIZONTAL
127.000000	27.10	14.6	43.5	16.4	---	0.0	0.00	HORIZONTAL
239.520000	44.10	13.7	46.0	1.9	---	0.0	0.00	HORIZONTAL
255.040000	30.50	14.3	46.0	15.5	---	0.0	0.00	HORIZONTAL
359.800000	33.50	17.2	46.0	12.5	---	0.0	0.00	HORIZONTAL
641.100000	32.60	22.6	46.0	13.4	---	0.0	0.00	HORIZONTAL



Above 1GHz:

Mode 1: Transmitter-1Mbps(GFSK_DH5)

CH	Antenna	Frequency (MHz)	Reading Level (dBuV/m)	Factor (dB)	Measure Level (dBuV/m)	Limit (dBuV/m)	Margin (dB)	Detector
0	V	2402	67.4	30.8	98.2	Fundamental	/	PK
	V	3200	13.6	31.1	44.7	54(note3)	9.3	PK
	V	2390	36.9	32.2	69.1	74	4.9	PK
	V	2390	17.3	32.2	49.5	54	4.5	AV
	V	2400	38.3	32.1	70.4	74	3.6	PK
	V	2400	18.5	32.1	50.6	54	3.4	AV
	V	4804	5.9	42.6	48.5	54(note3)	5.5	PK
	V	7206	20.8	46.5	67.3	74	6.7	PK
	V	7206	-2.3	46.5	44.2	54	9.8	AV
	H	24000	11.7	38.9	50.6	54	3.4	PK
39	V	2441	66.6	31.2	97.8	Fundamental	/	PK
	V	3200	12.0	31.1	43.1	54(note3)	10.9	PK
	V	4882	14.8	32.8	47.6	54(note3)	6.4	PK
	V	7323	21.7	46.8	68.5	74	5.5	PK
	V	7323	2.0	46.1	48.1	54	5.9	AV
	H	24000	11.7	38.9	50.6	54	3.4	PK
78	V	2480	65.9	30.9	96.8	Fundamental	/	PK
	V	3200	14.3	31.1	45.4	54(note3)	8.6	PK
	V	2483.5	33.5	30.2	63.7	74	10.3	PK
	V	2483.5	16.9	30.2	47.1	54	6.9	AV
	V	4960	16.1	32.5	48.6	54(note3)	5.4	PK
	V	7440	22.2	46.3	68.5	74	5.5	PK
	V	7440	0.8	46.3	47.1	54	6.9	AV
	H	24000	11.7	38.9	50.6	54	3.4	PK

Note: 1. Measure Level = Reading Level + Factor.

2. The test results which are attenuated more than 20 dB below the permissible value limit (the test frequency range: 9kHz~30MHz, 18GHz~25GHz), therefore no data appear in the report.

3. This limit applies for using average detector, if the test result on peak is lower than average limit, then average measurement needn't be performed.

Remark: RBW 1MHz VBW 3MHz peak detector for PK value, RMS detector for AV value

4. H and V polarity all have been tested ,only worse case is reported

Mode 2: Transmitter-2Mbps(Pi/4 DQPSK_2DH5)

CH	Antenna	Frequency (MHz)	Reading Level (dBuV/m)	Factor (dB)	Measure Level (dBuV/m)	Limit (dBuV/m)	Margin (dB)	Detector
0	V	2402	63.9	30.8	94.7	Fundamental	/	PK
	V	3200	9.4	31.1	40.5	54(note3)	13.5	PK
	V	2390	36.3	32.2	68.5	74	5.5	PK
	V	2390	15.0	32.2	47.2	54	6.8	AV
	V	2400	38.3	32.1	70.4	74	3.6	PK
	V	2400	16.5	32.1	48.6	54	5.4	AV
	V	4804	4.7	42.6	47.3	54(note3)	6.7	PK
	V	7206	21.6	46.5	68.1	74	5.9	PK
	V	7206	-2.9	46.5	43.6	54	10.4	AV
	H	24000	11.7	38.9	50.6	54	3.4	PK
39	V	2441	64.6	31.2	95.8	Fundamental	/	PK
	V	3200	12.1	31.1	43.2	54(note3)	10.8	PK
	V	4882	14.9	32.8	47.7	54(note3)	6.3	PK
	V	7323	21.7	46.8	68.5	74	5.5	PK
	V	7323	2.0	46.1	48.1	54	5.9	AV
	H	24000	11.7	38.9	50.6	54	3.4	PK
78	V	2480	63.3	30.9	94.2	Fundamental	/	PK
	V	3200	11.3	31.1	42.4	54(note3)	11.6	PK
	V	2483.5	32.7	30.2	62.9	74	11.1	PK
	V	2483.5	19.4	30.2	49.6	54	4.4	AV
	V	4960	16.3	32.5	48.8	54(note3)	5.2	PK
	V	7440	21.9	46.3	68.2	74	5.8	PK
	V	7440	1.1	46.3	47.4	54	6.6	AV
	H	24000	11.7	38.9	50.6	54	3.4	PK

Note: 1. Measure Level = Reading Level + Factor.

2. The test results which are attenuated more than 20 dB below the permissible value limit (the test frequency range: 9kHz~30MHz, 18GHz~25GHz), therefore no data appear in the report.

3. This limit applies for using average detector, if the test result on peak is lower than average limit, then average measurement needn't be performed.

Remark: RBW 1MHz VBW 3MHz peak detector for PK value, RMS detector for AV value

4. H and V polarity all have been tested ,only worse case is reported

Mode 3: Transmitter-3Mbps(8DPSK_3DH5)

CH	Antenna	Frequency (MHz)	Reading Level (dBuV/m)	Factor (dB)	Measure Level (dBuV/m)	Limit (dBuV/m)	Margin (dB)	Detector
0	V	2402	63.9	30.8	94.7	Fundamental	/	PK
	V	3200	9.4	31.1	40.5	54(note3)	13.5	PK
	V	2390	34.9	32.2	67.1	74	6.9	PK
	V	2390	13.2	32.2	45.4	54	8.6	AV
	V	2400	36.6	32.1	68.7	74	5.3	PK
	V	2400	18.2	32.1	50.3	54	3.7	AV
	V	4804	6.5	42.6	49.1	54(note3)	4.9	PK
	V	7206	23.0	46.5	69.5	74	4.5	PK
	V	7206	1.7	46.5	48.2	54	5.8	AV
	H	24000	11.7	38.9	50.6	54	3.4	PK
39	V	2441	63.9	31.2	95.1	Fundamental	/	PK
	V	3200	11.7	31.1	42.8	54(note3)	11.2	PK
	V	4882	14.8	32.8	47.6	54(note3)	6.4	PK
	V	7323	21.3	46.8	68.1	74	5.9	PK
	V	7323	1.4	46.1	47.5	54	6.5	AV
	H	24000	11.7	38.9	50.6	54	3.4	PK
78	V	2480	62.8	30.9	93.7	Fundamental	/	PK
	V	3200	17.1	31.1	48.2	54(note3)	5.8	PK
	V	2483.5	34.4	30.2	64.6	74	9.4	PK
	V	2483.5	13.3	30.2	43.5	54	10.5	AV
	V	4960	16.3	32.5	48.8	54(note3)	5.2	PK
	V	7440	21.3	46.3	67.6	74	6.4	PK
	V	7440	-1.1	46.3	45.2	54	8.8	AV
	H	24000	11.7	38.9	50.6	54	3.4	PK

Note: 1. Measure Level = Reading Level + Factor.

2. The test results which are attenuated more than 20 dB below the permissible value limit (the test frequency range: 9kHz~30MHz, 18GHz~25GHz), therefore no data appear in the report.

3. This limit applies for using average detector, if the test result on peak is lower than average limit, then average measurement needn't be performed.

Remark: RBW 1MHz VBW 3MHz peak detector for PK value, RMS detector for AV value

4. H and V polarity all have been tested ,only worse case is reported

4.3. Maximum Peak Output Power

TEST CONFIGURATION

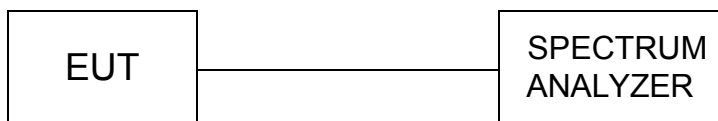

TEST PROCEDURE

According to ANSI C63.10: 2013.

Use the following spectrum analyzer settings:

Span = approximately 5 times the 20dB bandwidth, centered on a hopping channel

RBW > the 20 dB bandwidth of the emission being measured.

VBW \geq RBW, Sweep = auto, Detector function = peak, Trace = max hold

Allow the trace to stabilize. Use the marker-to-peak function to set the marker to the peak of the emission. The indicated level is the peak output power (don't forget added the external attenuation and cable loss).

LIMIT

The Maximum Peak Output Power Measurement limit is 30dBm.

TEST RESULTS

DH5 Mode:

Channel Frequency (MHz)	Peak Power Output (dBm)	Peak Power Limit (dBm)	Pass / Fail
2402	3.14	30	PASS
2441	2.89	30	PASS
2480	2.57	30	PASS

Note: The test results including the cable lose.

2DH5 Mode:

Channel Frequency (MHz)	Peak Power Output (dBm)	Peak Power Limit (dBm)	Pass / Fail
2402	2.38	30	PASS
2441	3.02	30	PASS
2480	2.04	30	PASS

Note: The test results including the cable lose.

3DH5 Mode:

Channel Frequency (MHz)	Peak Power Output (dBm)	Peak Power Limit (dBm)	Pass / Fail
2402	2.21	30	PASS
2441	1.85	30	PASS
2480	1.47	30	PASS

Note: The test results including the cable lose.



4.4. 20dB Bandwidth and 99% Bandwidth

TEST CONFIGURATION

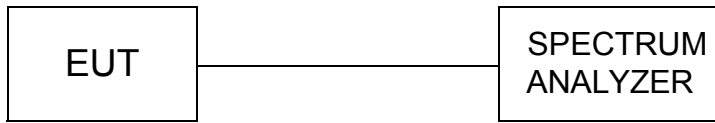

TEST PROCEDURE

According to ANSI C63.10: 2013.

Use the following spectrum analyzer settings:

Span = approximately 2 to 3 times the 20dB bandwidth, centered on a hopping channel

RBW \cong 1% of the 20dB bandwidth, VBW \cong RBW, Sweep = auto, Detector function = peak, Trace = max hold

The EUT should be transmitting at its maximum data rate. Allow the trace to stabilize.

Use the marker-to-peak function to set the marker to the peak of the emission. Use the marker-delta function to measure 20 dB down one side of the emission. Reset the marker-delta function, and move the marker to the other side of the emission, until it is (as close as possible to) even with the reference marker level. The marker-delta reading at this point is the 20 dB bandwidth of the emission. If this value varies with different modes of operation (e.g., data rate, modulation format, etc.), repeat this test for each variation.

LIMIT

For frequency hopping systems operating in the 2400MHz-2483.5MHz no limit for 20dB bandwidth.

TEST RESULTS

DH5 Mode:

CHANNEL FREQUENCY (MHZ)	20DB BANDWIDTH (KHZ)	99% BANDWIDTH (MHZ)	LIMIT (MHz)	PASS/FAIL
2402	922.292	861.1194	/	PASS
2441	941.003	857.4424	/	PASS
2480	942.449	860.5757	/	PASS

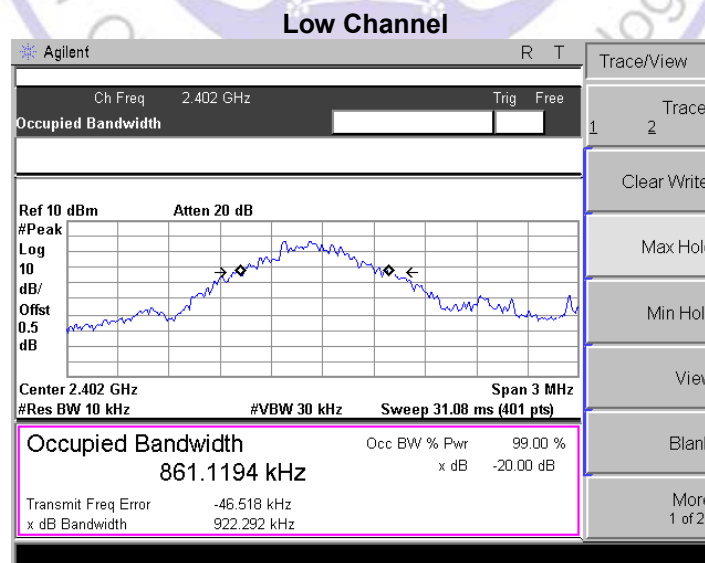

Middle Channel

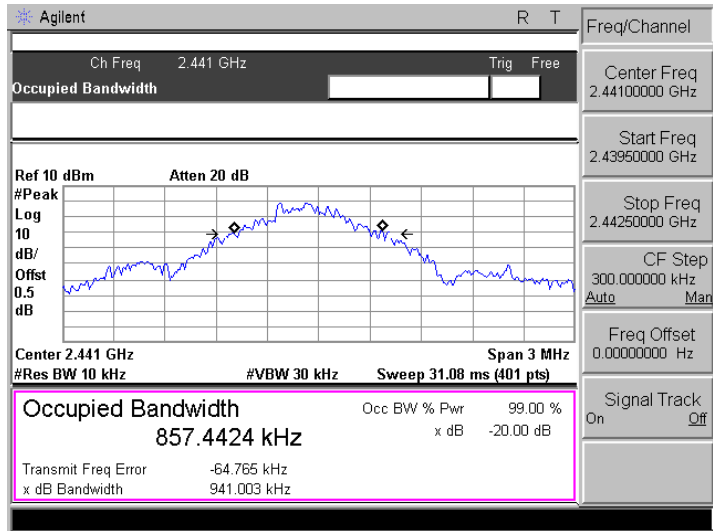

High Channel

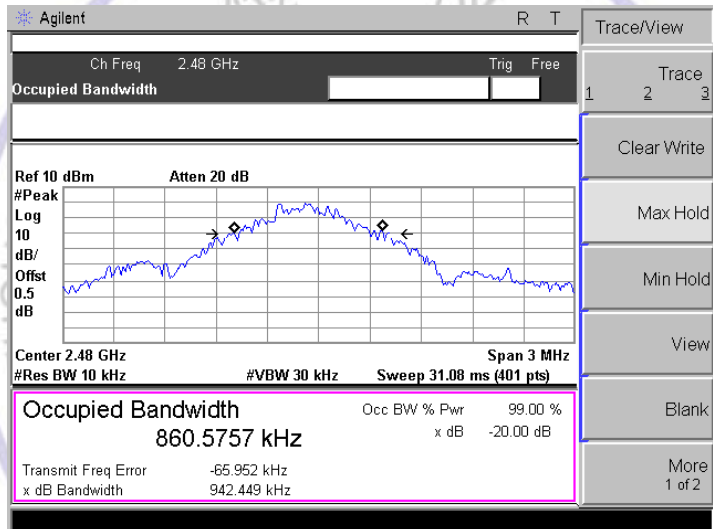

2DH5 Mode:

CHANNEL FREQUENCY (MHZ)	20DB BANDWIDTH (MHZ)	99% BANDWIDTH (MHZ)	LIMIT (MHz)	PASS/FAIL
2402	1.311	1.1866	/	PASS
2441	1.322	1.1788	/	PASS
2480	1.221	1.1637	/	PASS

Low Channel

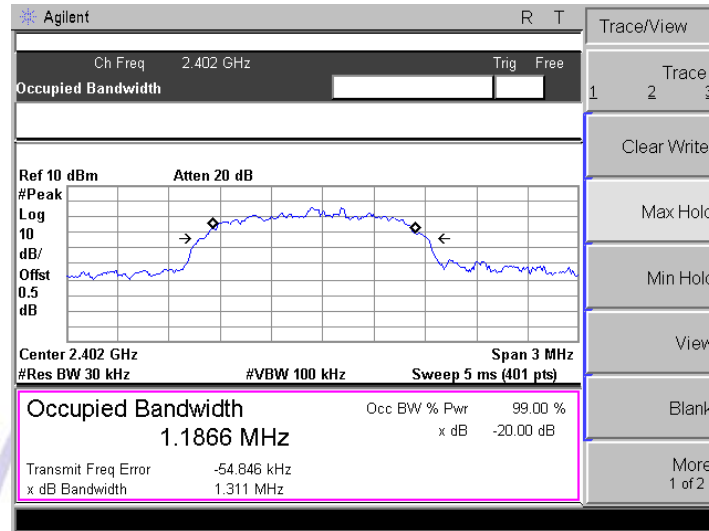

Middle Channel

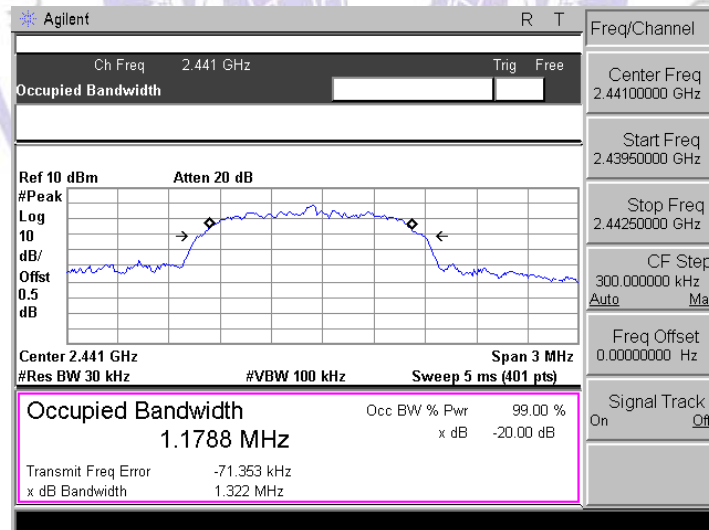

High Channel

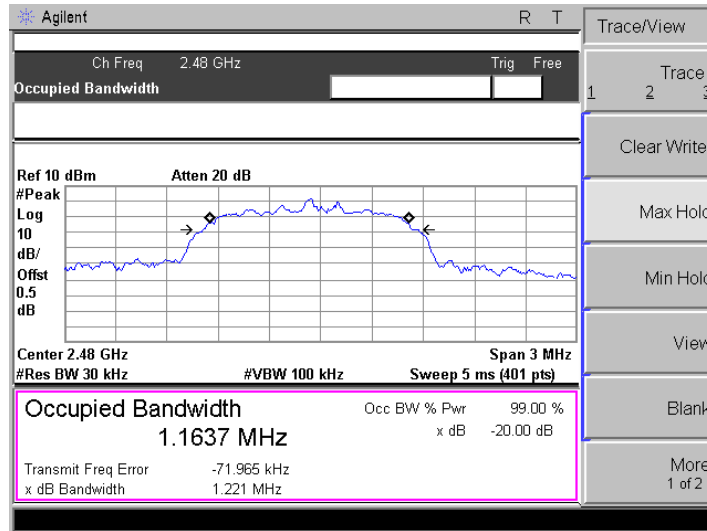

3DH5 Mode:

CHANNEL FREQUENCY (MHZ)	20DB BANDWIDTH (MHZ)	99% BANDWIDTH (MHZ)	LIMIT (MHZ)	PASS/FAIL
2402	1.272	1.1662	/	PASS
2441	1.280	1.1739	/	PASS
2480	1.262	1.1610	/	PASS

Low Channel

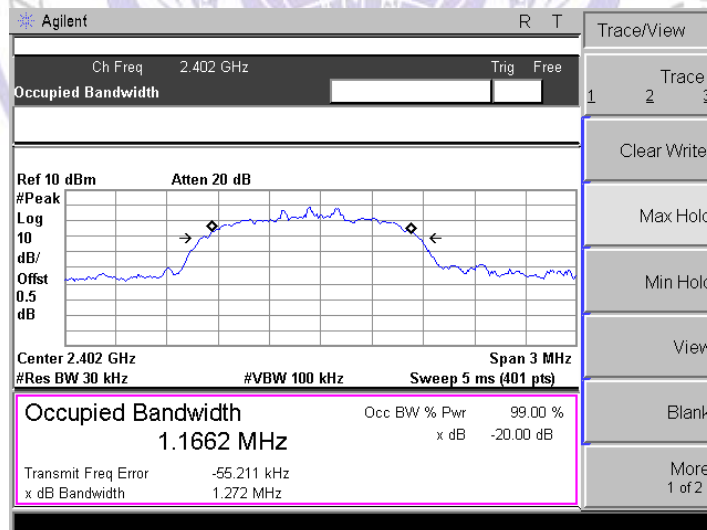

Middle Channel

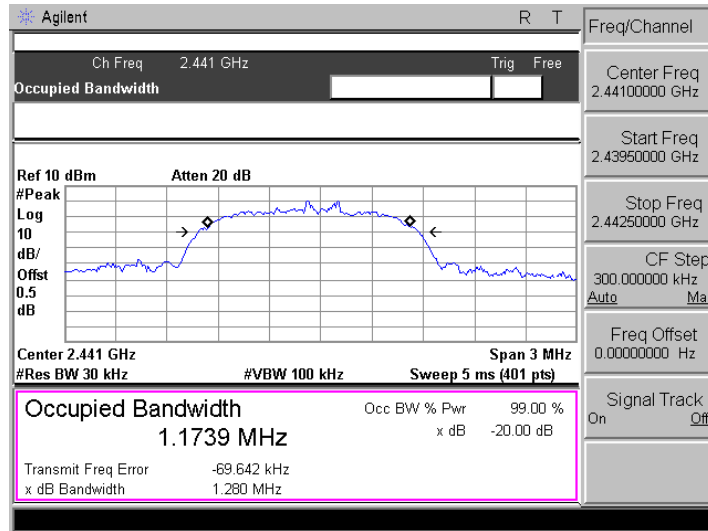

High Channel

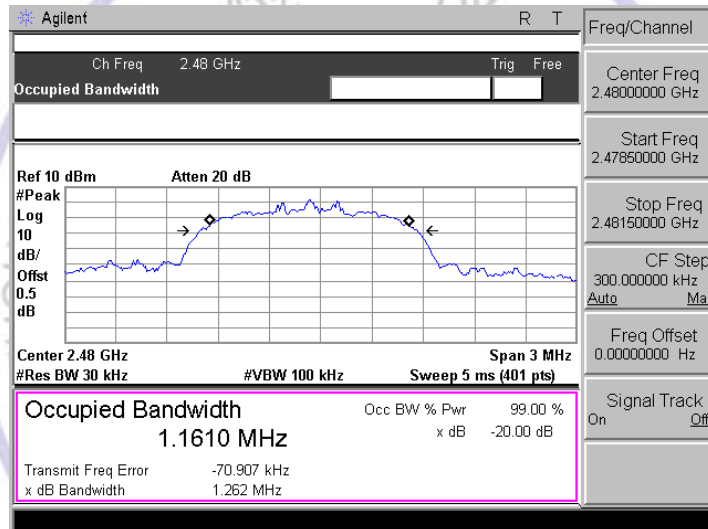

4.5. Frequency Separation

TEST CONFIGURATION

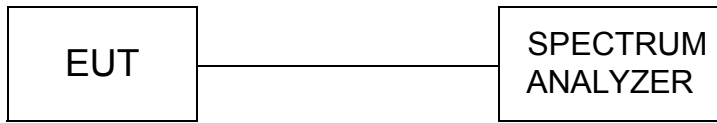

TEST PROCEDURE

According to ANSI C63.10: 2013.

The EUT must have its hopping function enabled.

Use the following spectrum analyzer settings:

Span = wide enough to capture the peaks of two adjacent channels

Resolution (or IF) Bandwidth (RBW) \cong 1% of the span

Video (or Average) Bandwidth VBW \cong RBW

Sweep = auto

Detector function = peak

Trace = max hold

Allow the trace to stabilize. Use the marker-delta function to determine the separation between the peaks of the adjacent channels.

LIMIT

According to 15.247(a)(1), frequency hopping systems shall have hopping channel carrier frequencies separated by minimum of 25KHz or the 2/3*20dB bandwidth of the hopping channel, whichever is greater.

TEST RESULTS

Photos of Frequency separation Measurement

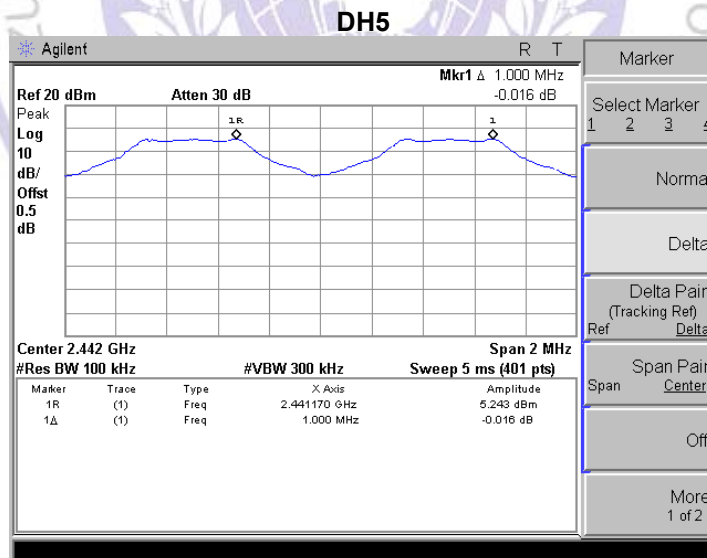

2DH5

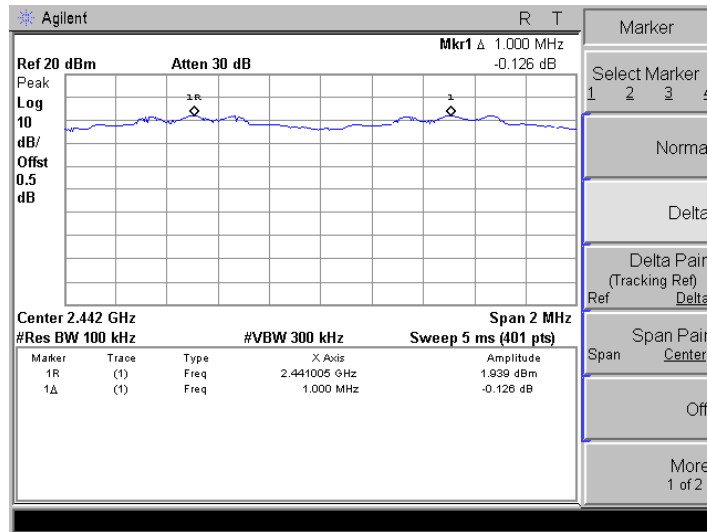

3DH5

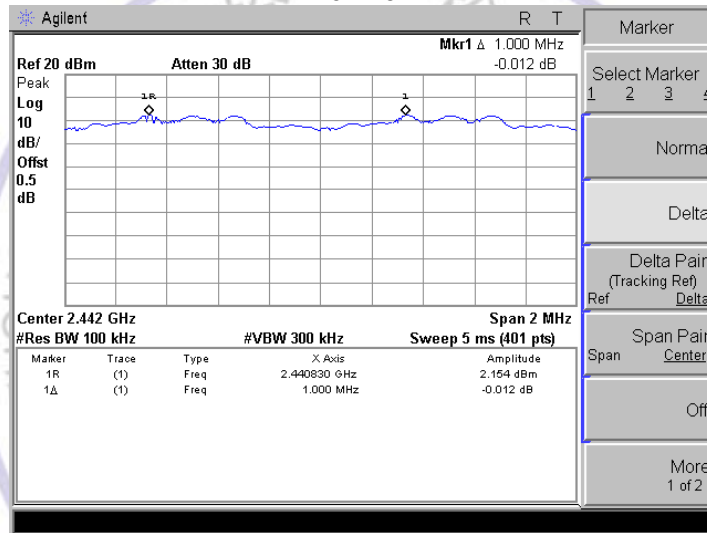

4.6. Number of hopping frequency

TEST CONFIGURATION

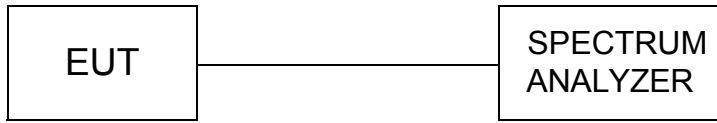

TEST PROCEDURE

According to ANSI C63.10: 2013.

The EUT must have its hopping function enabled.

Use the following spectrum analyzer settings:

Span = the frequency band of operation

RBW \geq 1% of the span

VBW \geq RBW

Sweep = auto

Detector function = peak

Trace = max hold

Allow the trace to stabilize. It may prove necessary to bread the span up to sections, in order to clearly show all of the hopping frequencies.

LIMIT

Frequency hopping systems in the 2400–2483.5 MHz band shall use at least 15 channels.

TEST RESULTS

DH5 Mode:

Hopping Channel Frequency Range (MHz)	Number of Hopping Channel	Limit
2400-2483.5	79	≥ 15

Photos of Number of hopping channel Measurement

2402-2421MHz

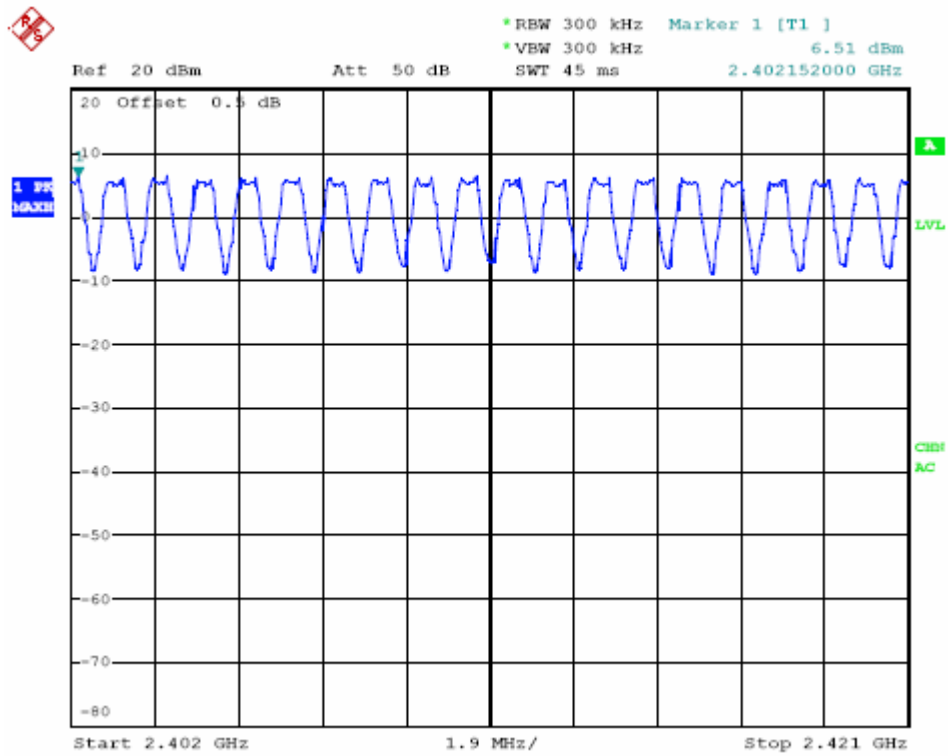

2422-2441MHz

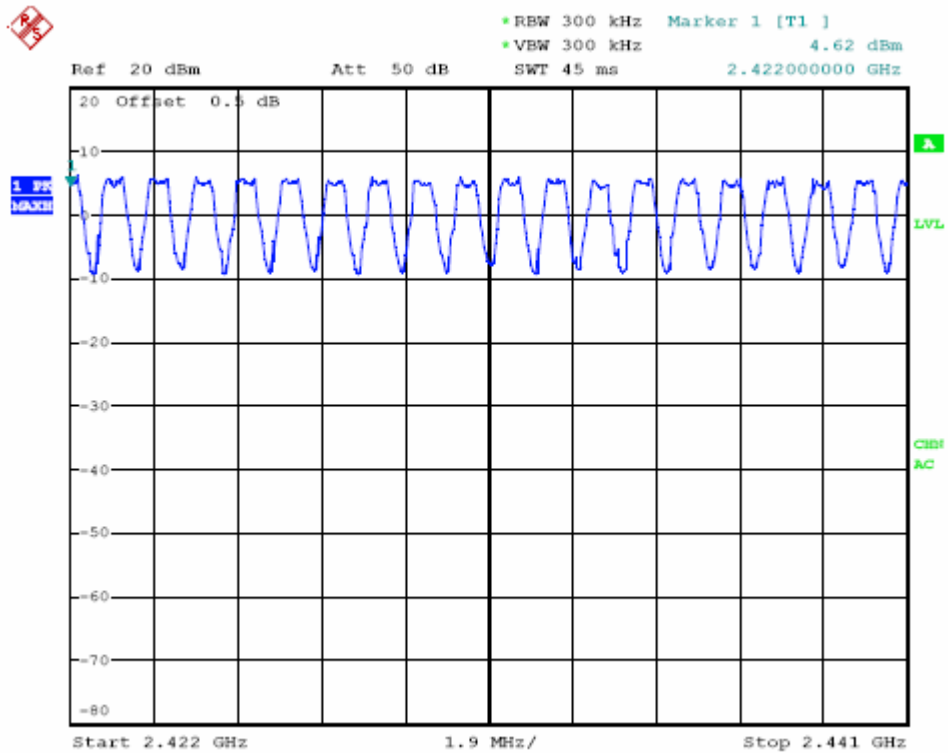

2442-2461MHz

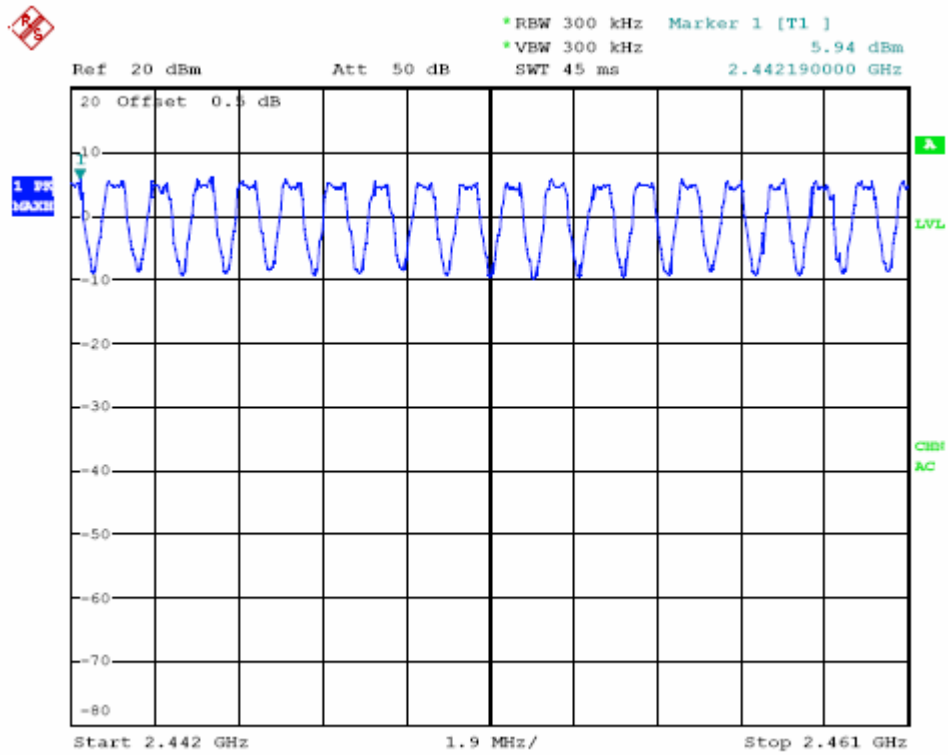

2462-2480MHz

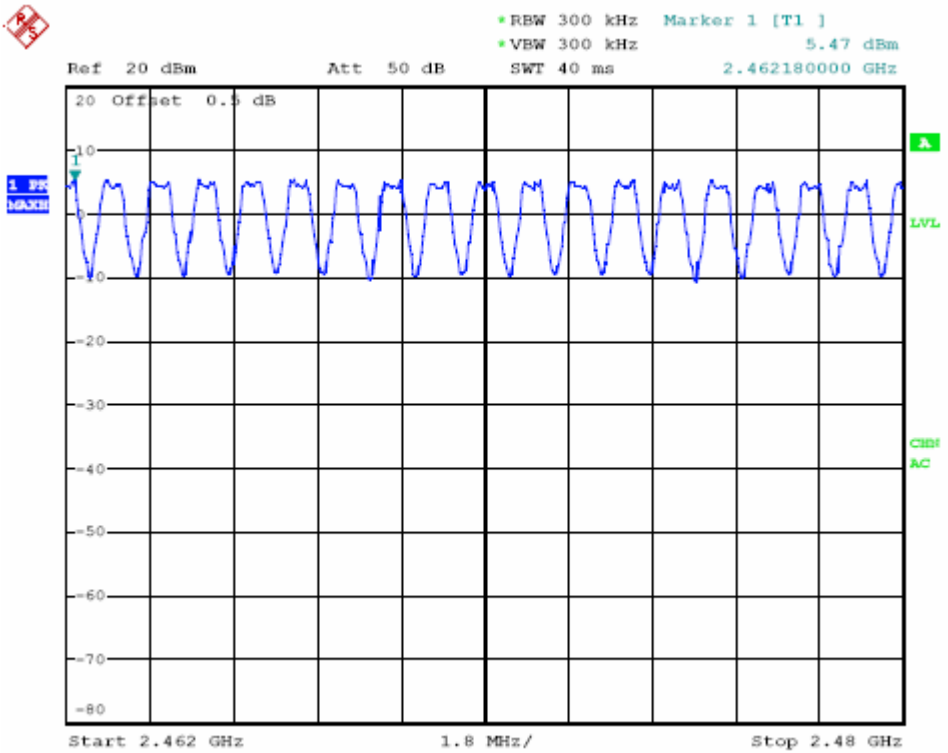

2DH5 Mode:

Hopping Channel Frequency Range (MHz)	Number of Hopping Channel	Limit
2400-2483.5	79	≥15

Photos of Number of hopping channel Measurement

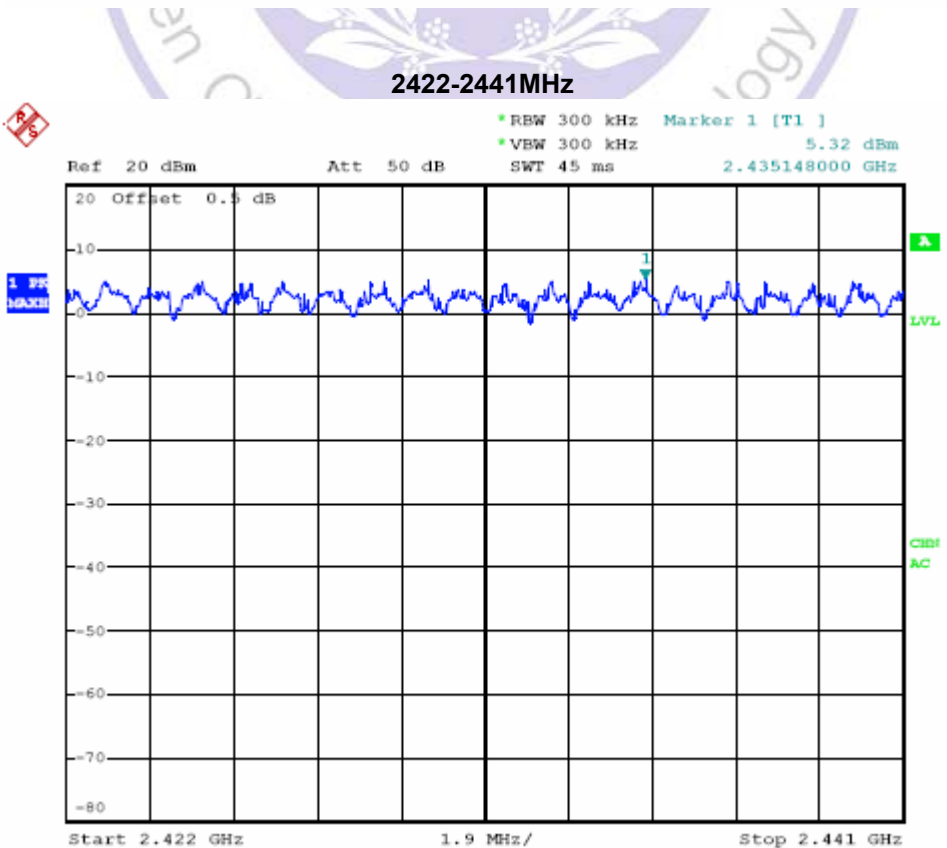
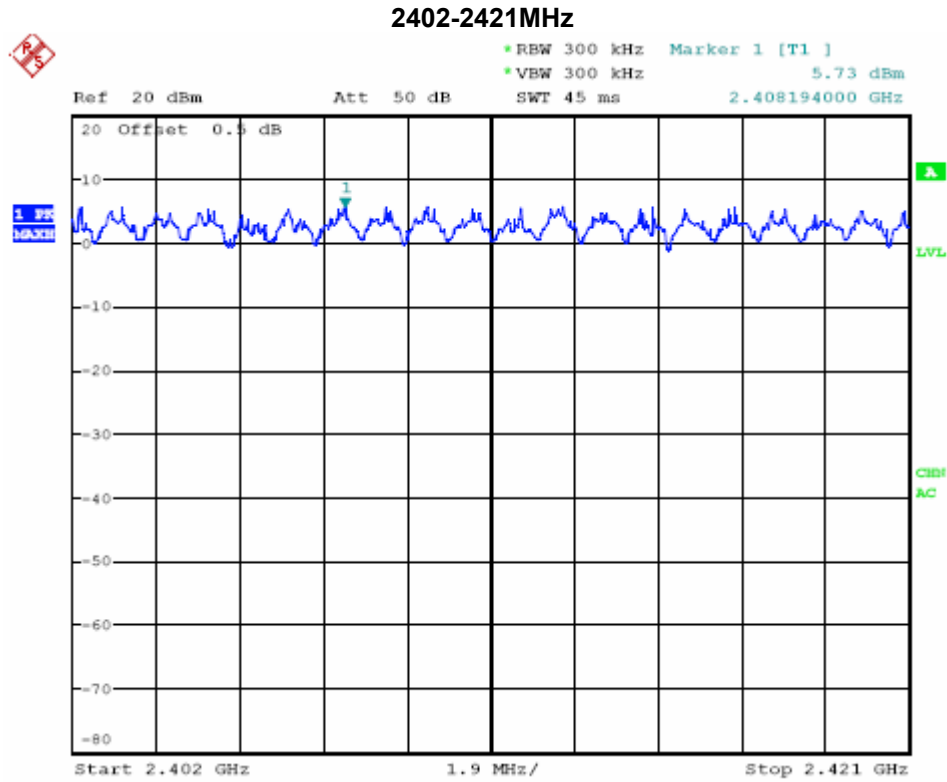

2442-2461MHz

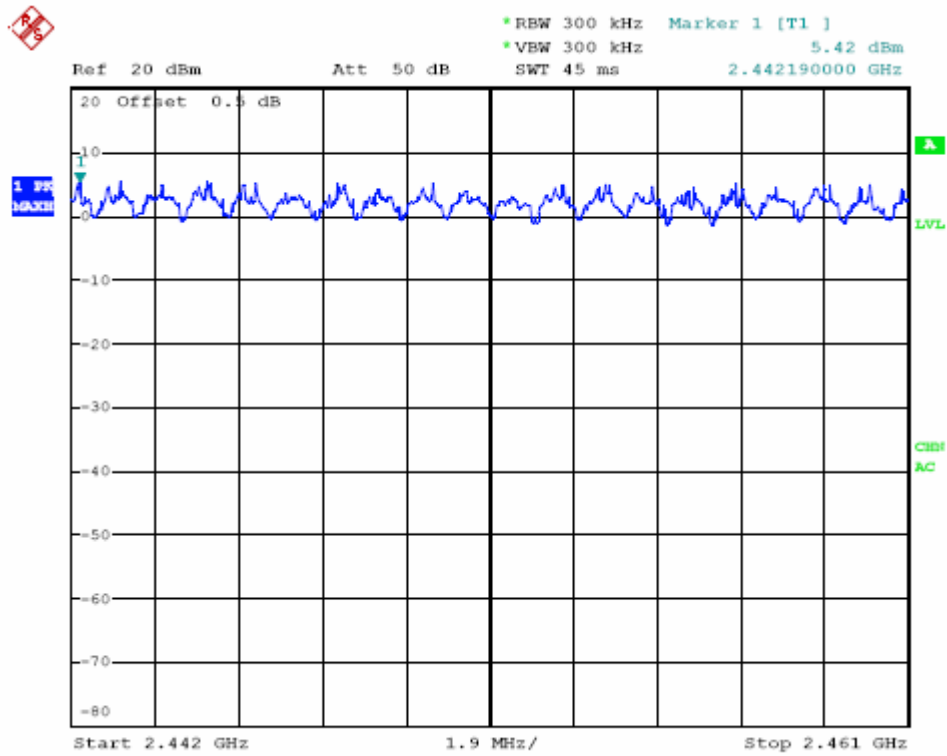

2462-2480MHz

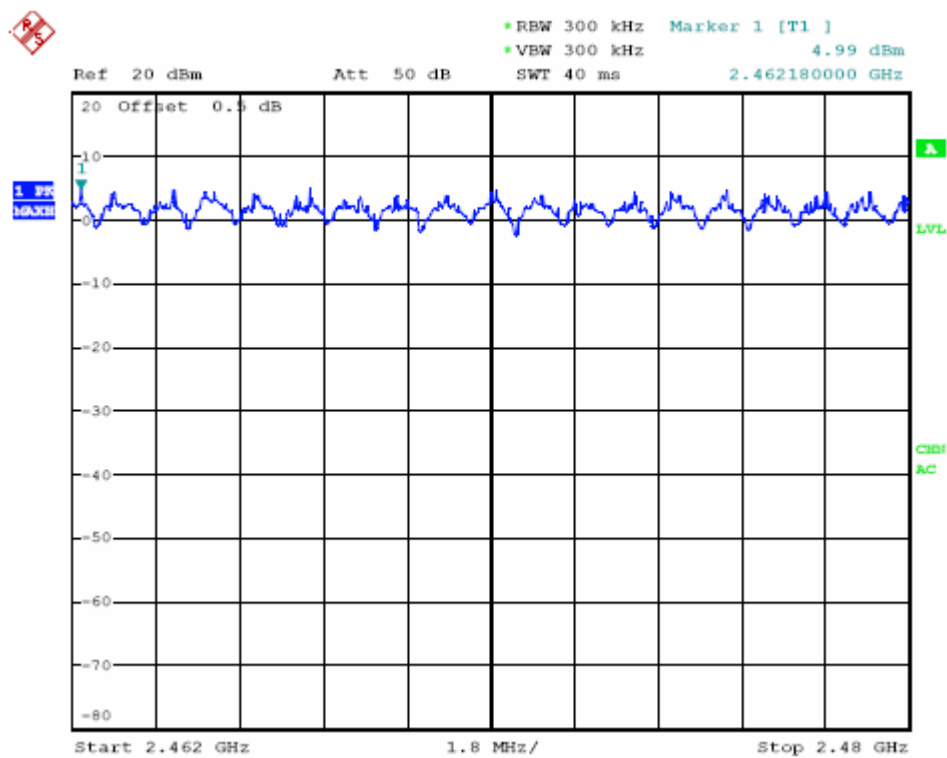

3DH5 Mode:

Hopping Channel Frequency Range (MHz)	Number of Hopping Channel	Limit
2400-2483.5	79	≥15

Photos of Number of hopping channel Measurement

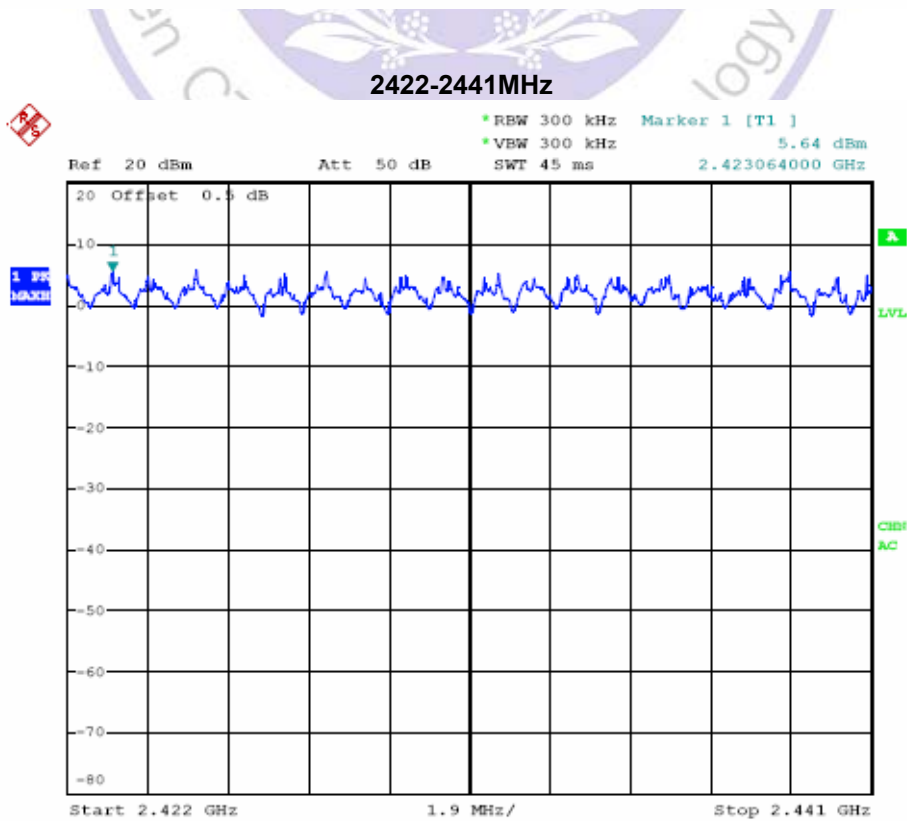
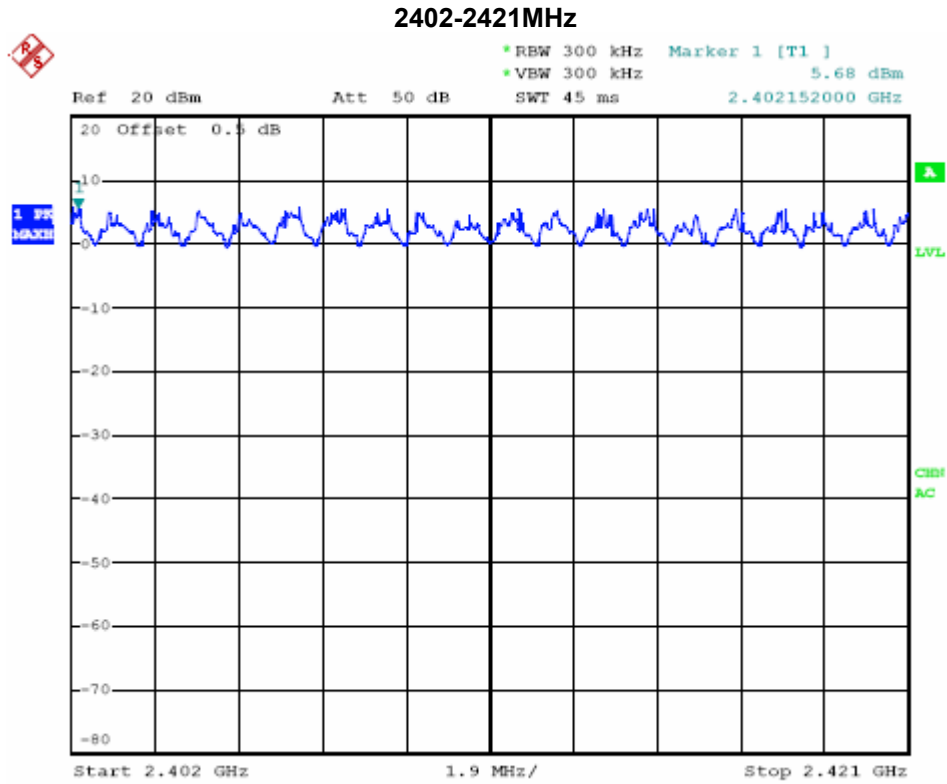

2442-2461MHz

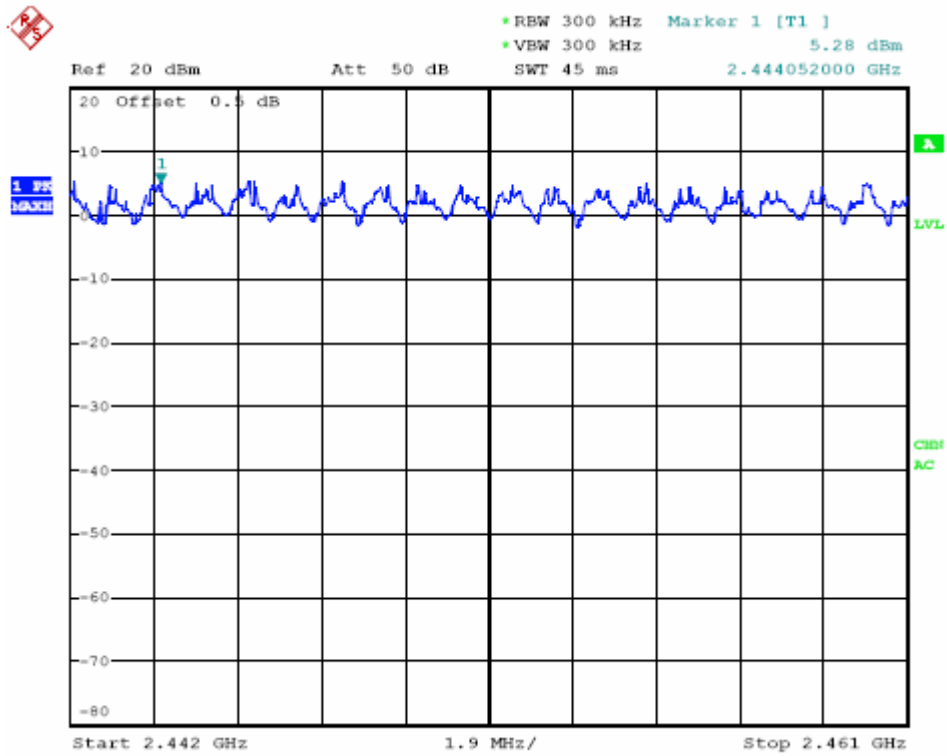

2462-2480MHz

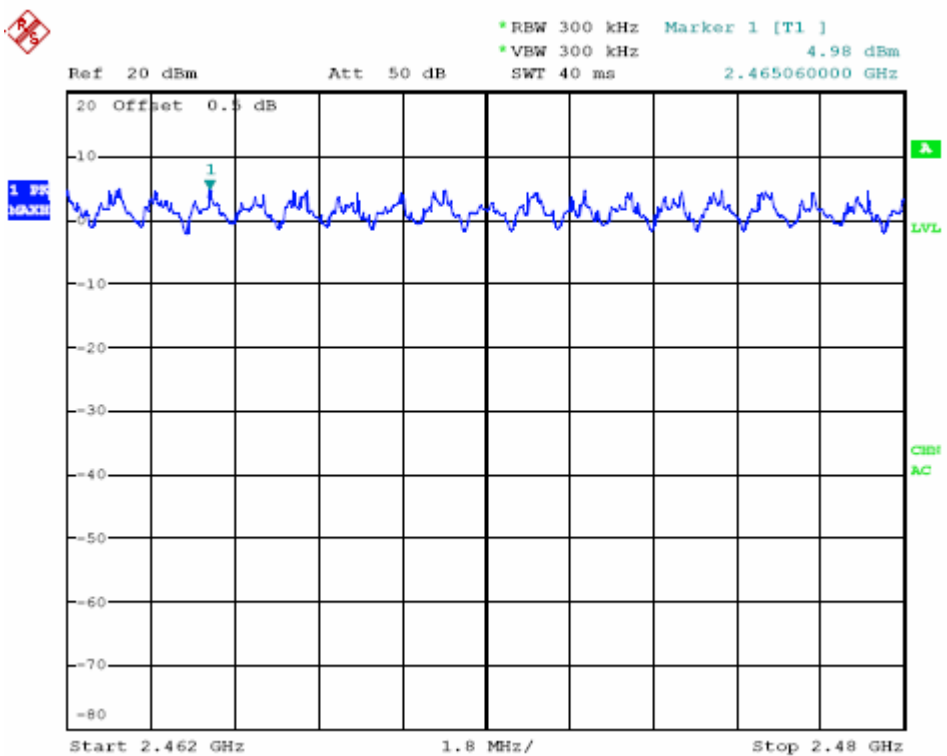

4.7. Time Of Occupancy(Dwell Time)

TEST CONFIGURATION

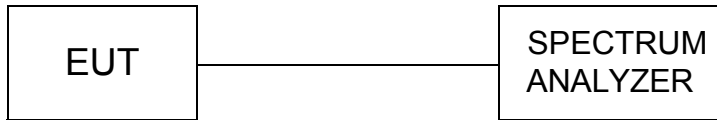

TEST PROCEDURE

According to ANSI C63.10: 2013.

The EUT must have its hopping function enabled.

Use the following spectrum analyzer settings:

Span = zero span, centered on a hopping channel

RBW = 1MHz

VBW \cong RBW

Sweep = as necessary to capture the entire dwell time per hopping channel

Detector function = peak

Trace = max hold

If possible, use the marker-delta function to determine the dwell time. If this value varies with different modes of operation (e.g., data rate, modulation format, etc.), repeat this test for each variation.

LIMIT

The average time of occupancy on any channel shall not be greater than 0.4 seconds within a pe-riod of 0.4 seconds multiplied by the number of hopping channels employed.

TEST RESULTS

Frequency (MHz)	Mode	Pulse Width (ms)	Dwell Time (S)	Limit (S)	Result
2441	DH1	0.430	0.138	0.4	Pass
	DH3	1.725	0.276	0.4	Pass
	DH5	3.000	0.320	0.4	Pass
Note: DH1: Dwell time=Pulse time (ms) \times (1600 \div 2 \div 79) \times 31.6 Second DH3: Dwell time=Pulse time (ms) \times (1600 \div 4 \div 79) \times 31.6 Second DH5: Dwell time=Pulse time (ms) \times (1600 \div 6 \div 79) \times 31.6 Second					

Photos of Dwell Time Measurement:

DH1

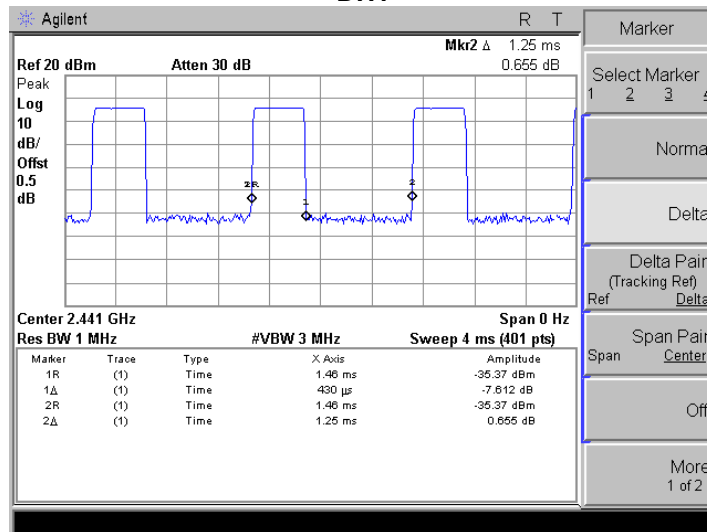

DH3

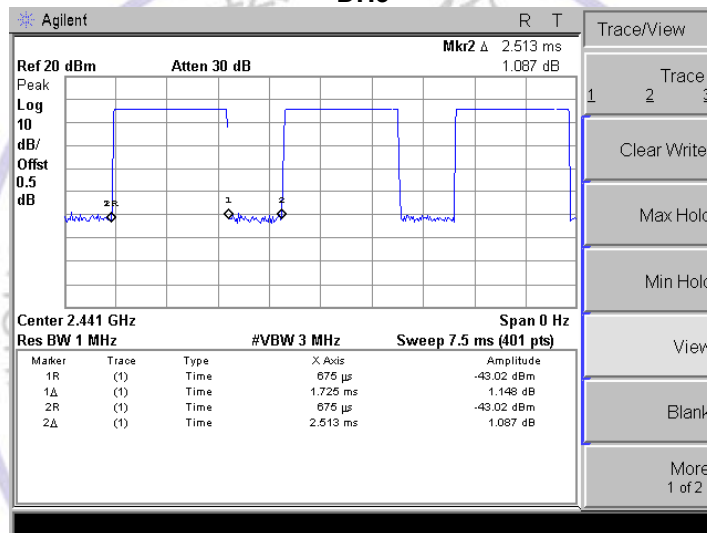

DH5

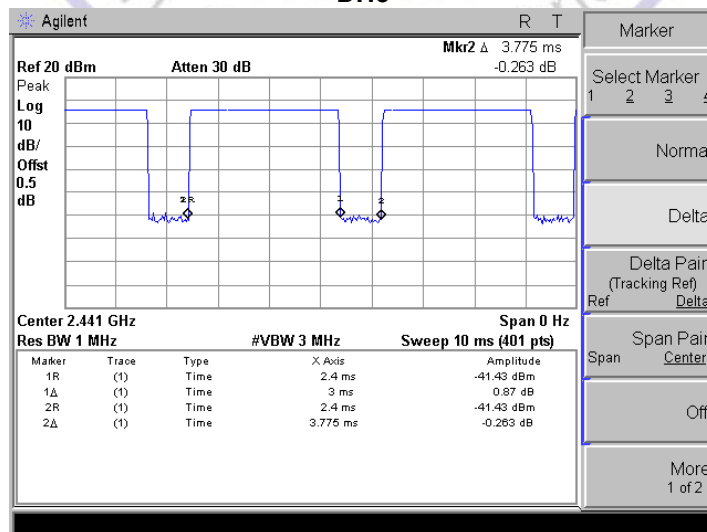

4.8. Spurious RF Conducted Emissions and bandedge

TEST CONFIGURATION

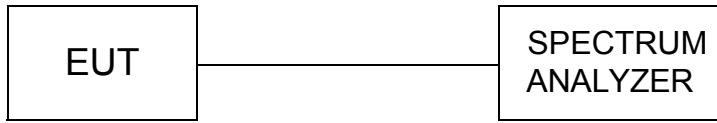

TEST PROCEDURE

According to ANSI C63.10: 2013.

The EUT must have its hopping function enabled.

Use the following spectrum analyzer settings:

Span = wide enough to capture the peak level of the in-band emission and all spurious emissions (e.g., harmonics) from the lowest frequency generated in the EUT up through the 10th harmonic. Typically, several plots are required to cover this entire span.

RBW = 100KHz, VBW ≥ RBW, Sweep =auto, Detector function = peak, Trace = max hold

Allow the trace to stabilize. Set the marker on the peak of any spurious emission recorded. The level displayed must comply with the limit specified in this section.

LIMIT

In any 100 kHz bandwidth outside the frequency band in which the spread spectrum or digitally modulated intentional radiator is operating, the radio frequency power that is produced by the intentional radiator shall be at least 20 dB below that in the 100 kHz bandwidth within the band that contains the highest level of the desired power, based on either an RF conducted or a radiated measurement, provided the transmitter demonstrates compliance with the peak conducted or a radiated measurement, provided the transmitter demonstrates compliance with the peak conducted power limits. If the transmitter complies with the conducted power limits based on the use of RMS averaging over a time interval, the attenuation required under this paragraph shall be 30 dB instead of 20 dB. Attenuation below the general limits specified in Section 15.209(a) of FCC part 15 is not required.

TEST RESULT

DH5 Mode:

Low Channel

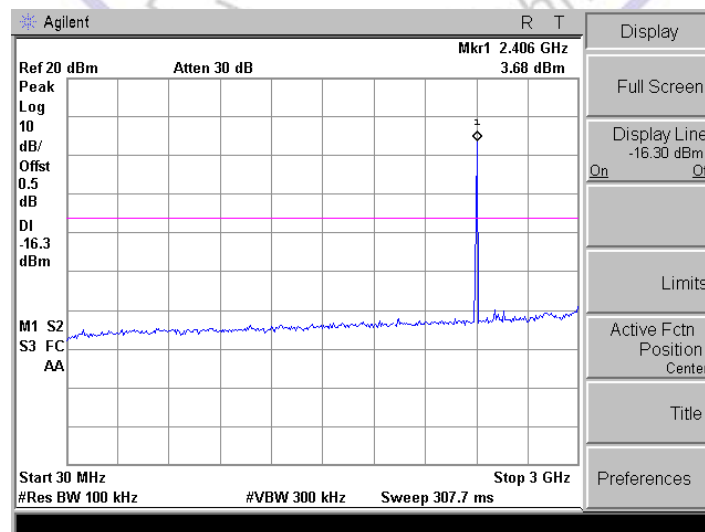

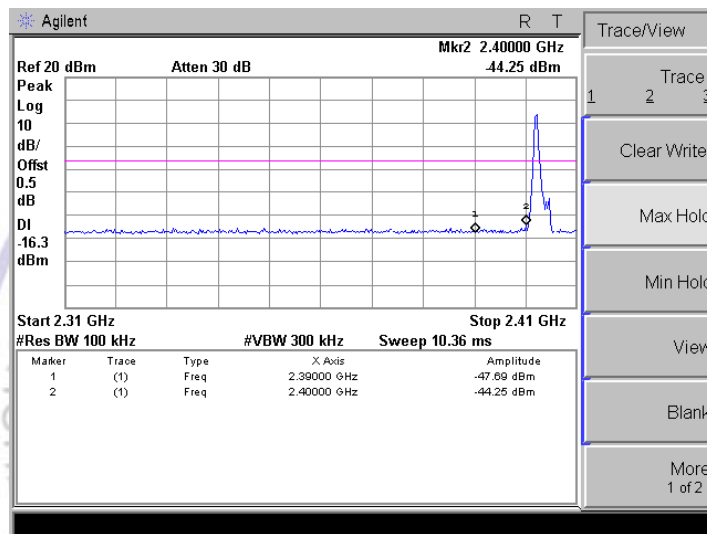
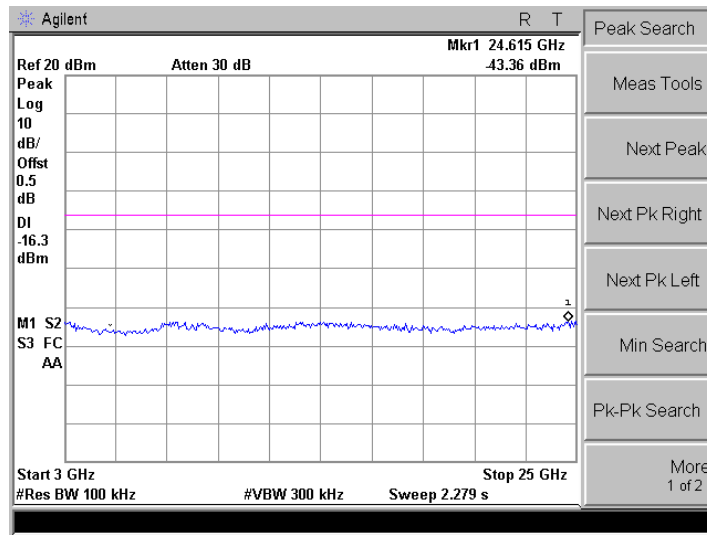

Middle Channel

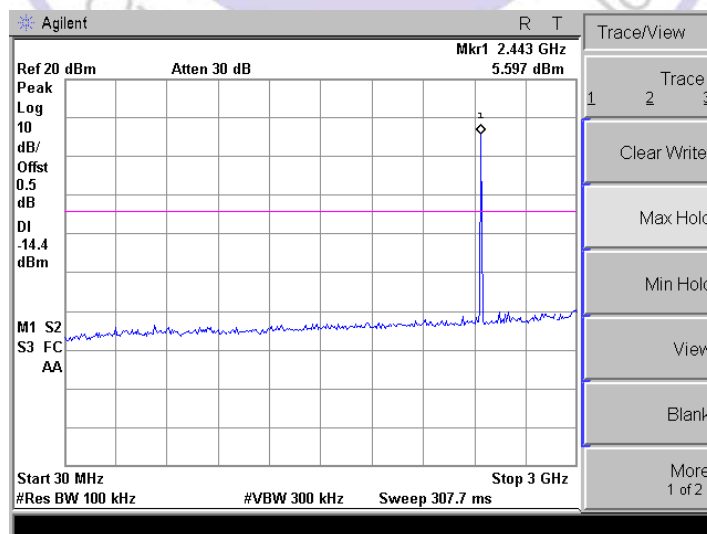

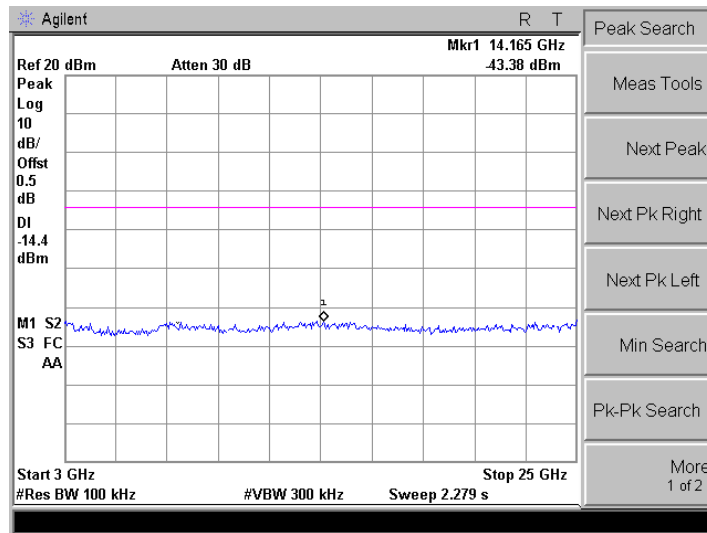

High Channel

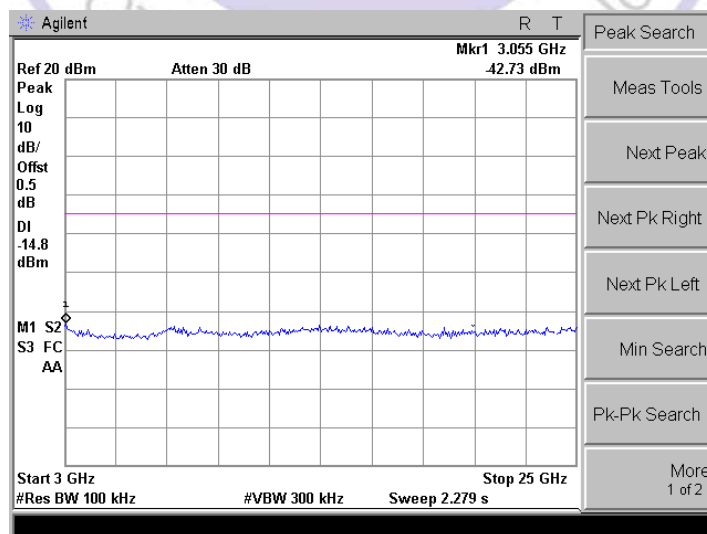
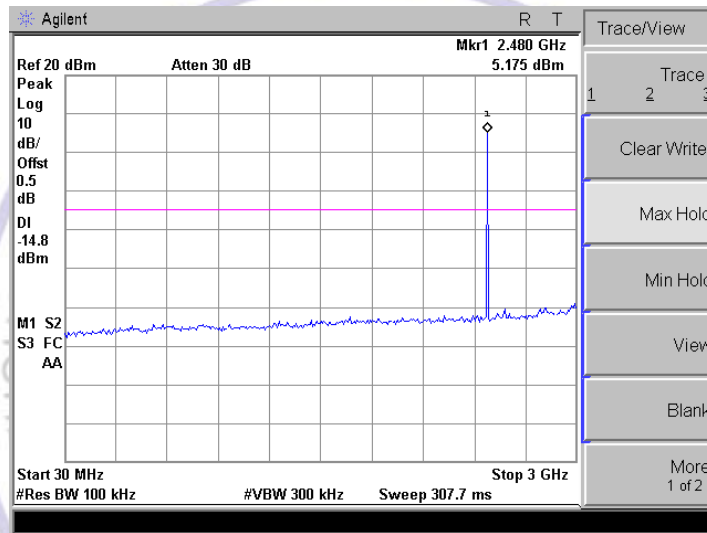

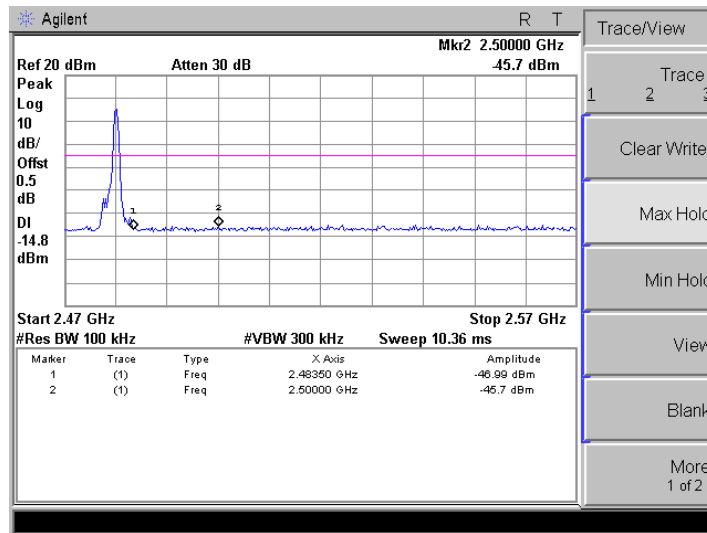

2DH5 Mode:

Low Channel

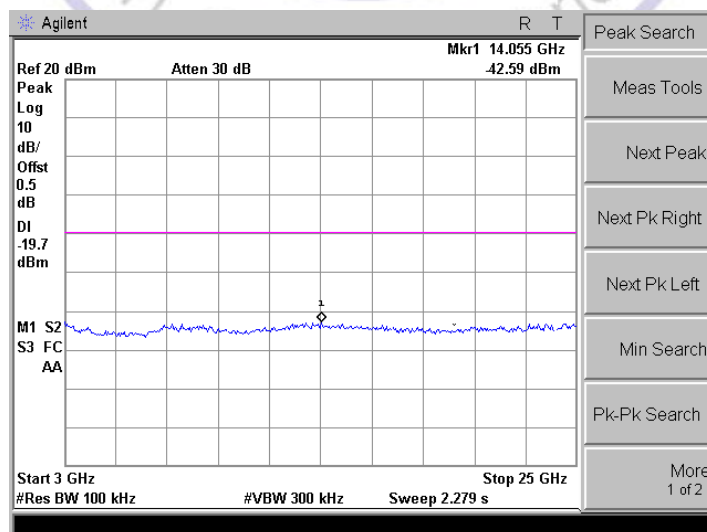
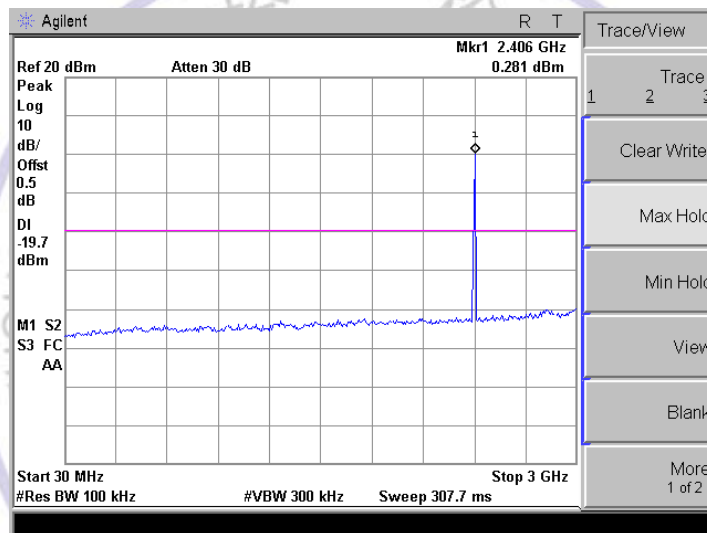

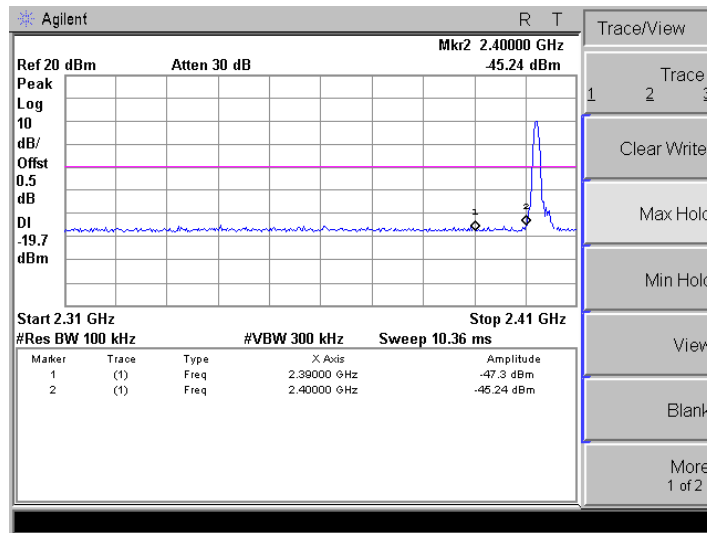

Middle Channel

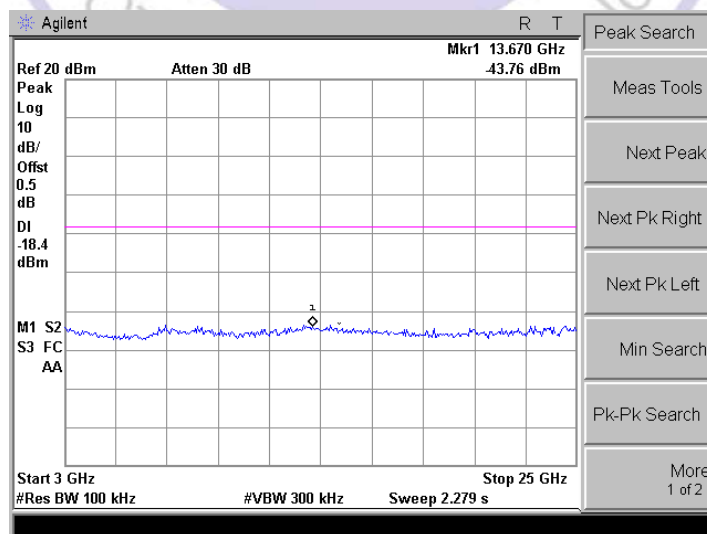
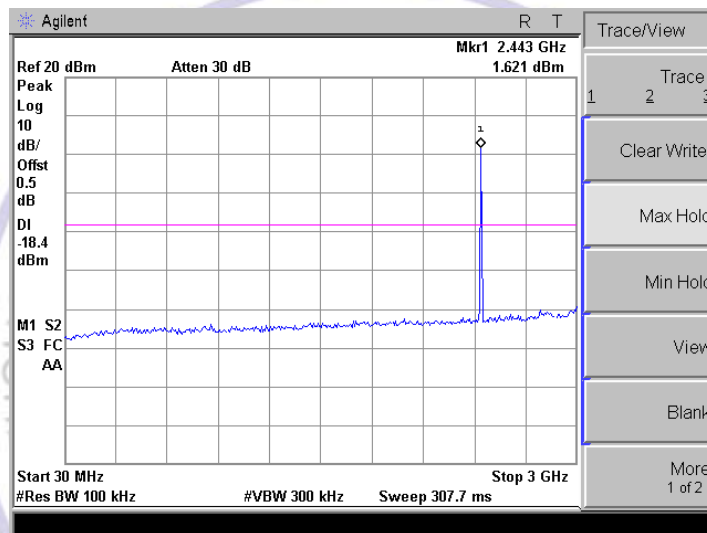

High Channel

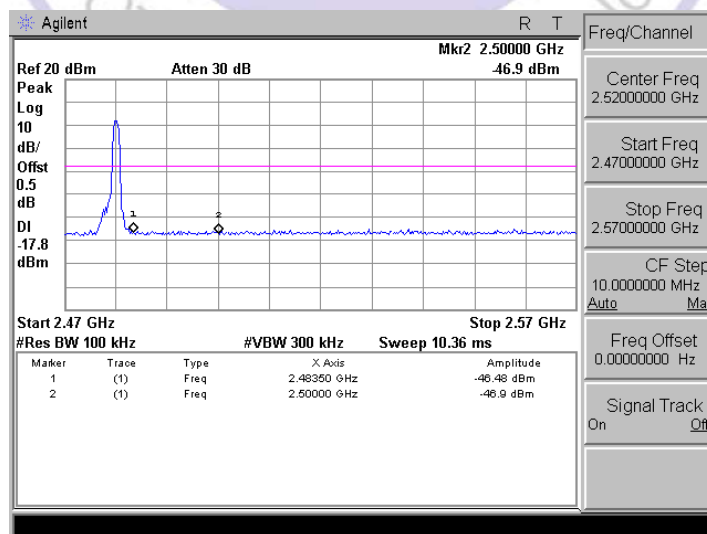
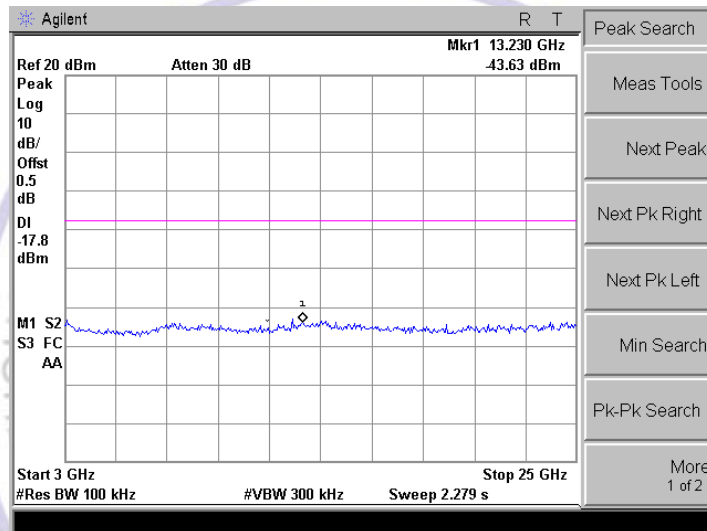
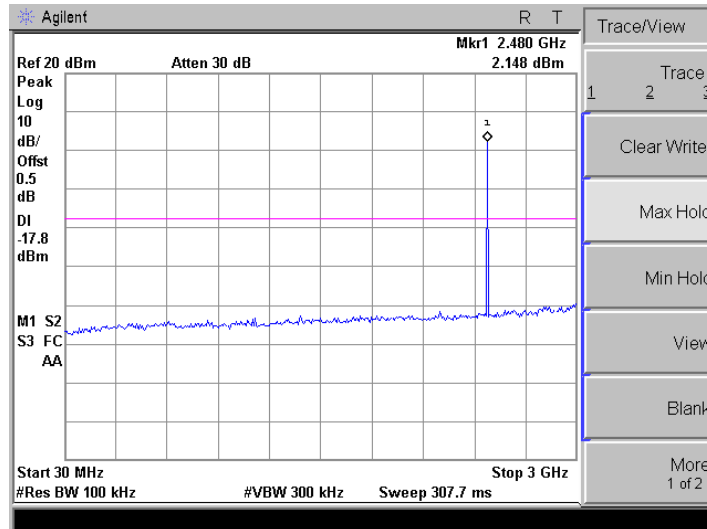

3DH5 Mode;

Low Channel

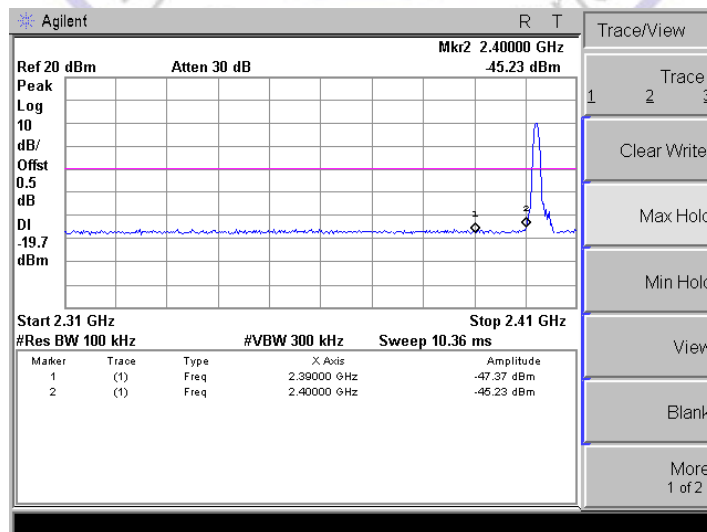
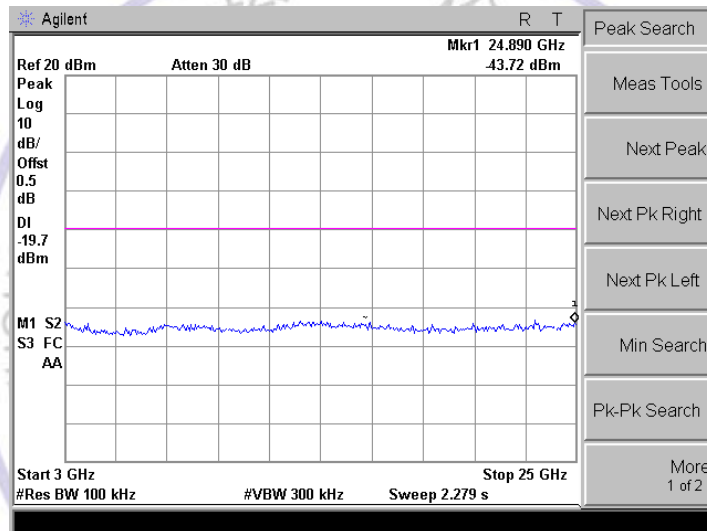
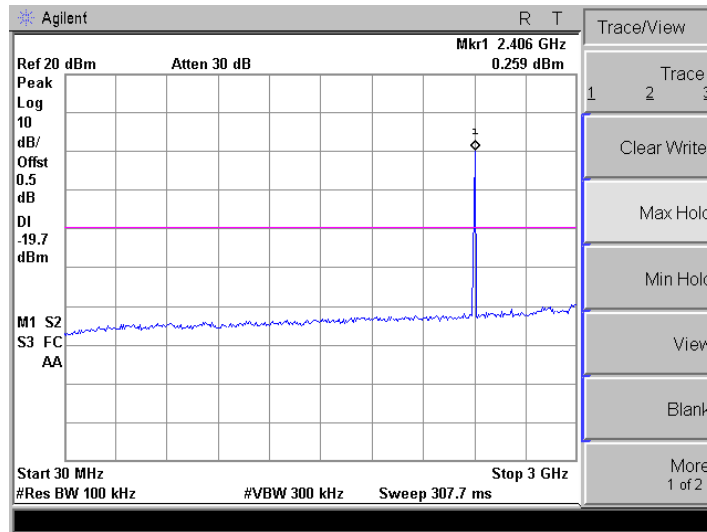

Middle Channel

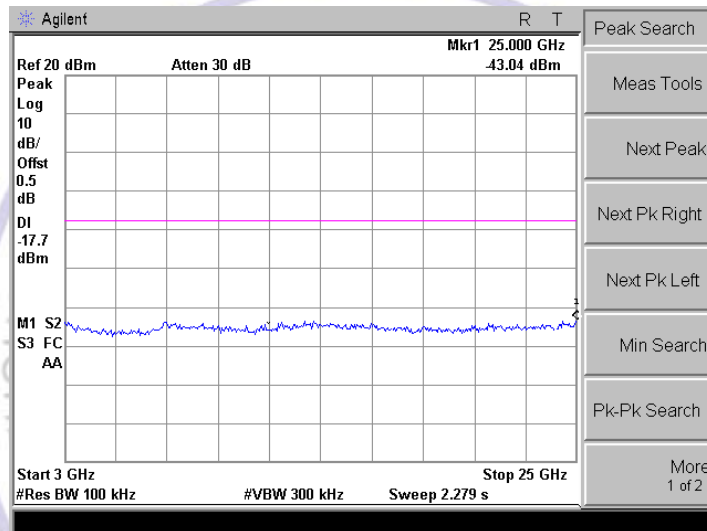
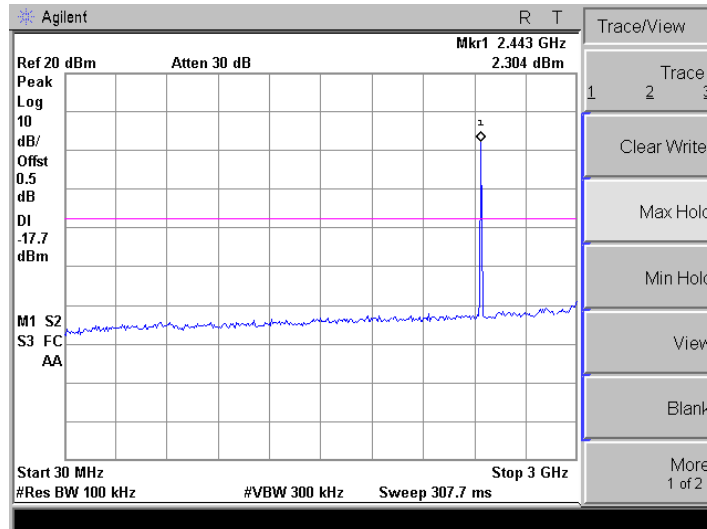

High Channel

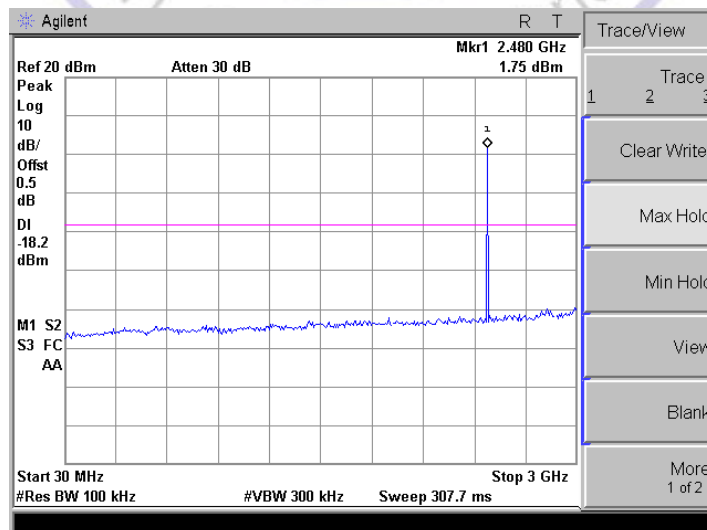

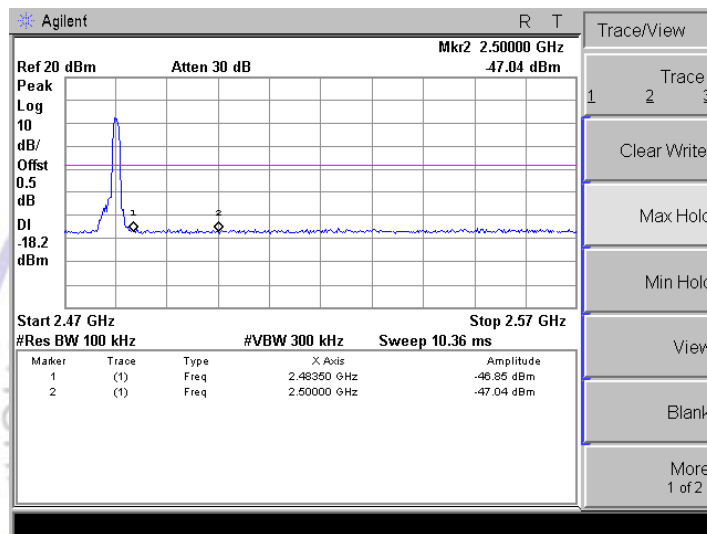
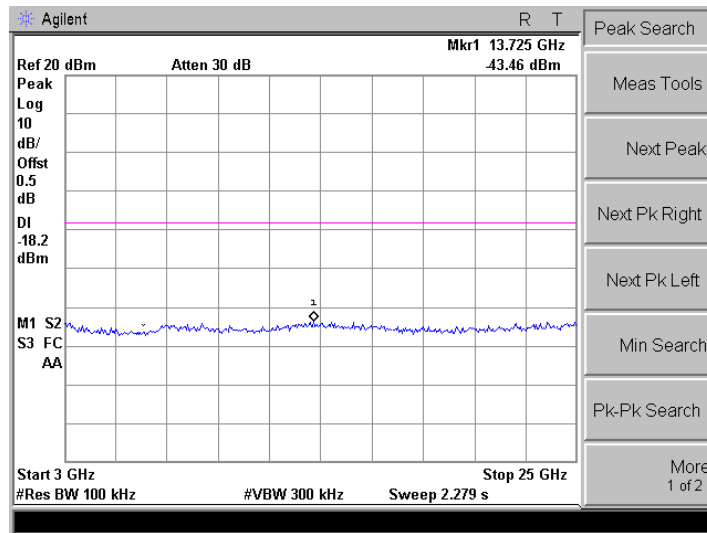

Hopping mode



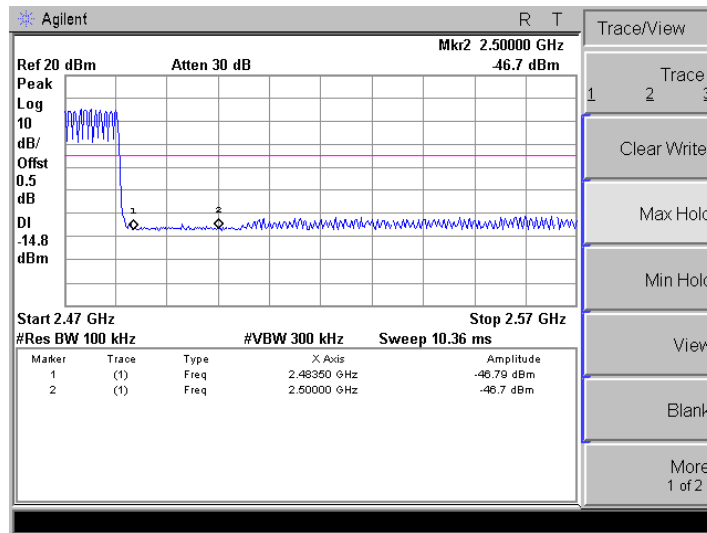

4.9. Antenna Requirement

Standard Applicable

For intentional device, according to FCC 47 CFR Section 15.203, an intentional radiator shall be designed to ensure that no antenna other than that furnished by the responsible party shall be used with the device.

And according to FCC 47 CFR Section 15.247 (c), if transmitting antennas of directional gain greater than 6dBi are used, the power shall be reduced by the amount in dB that the directional gain of the antenna exceeds 6dBi.

Refer to statement below for compliance.

The manufacturer may design the unit so that the user can replace a broken antenna, but the use of a standard antenna jack or electrical connector is prohibited. Further, this requirement does not apply to intentional radiators that must be professionally installed.

Antenna Connected Construction

The antenna used in this product is a internal Antenna, The directional gains of antenna used for transmitting is 0 dBi.



5. Test Setup Photos of the EUT





6. External and Internal Photos of the EUT

External Photos of EUT





Internal Photos of EUT

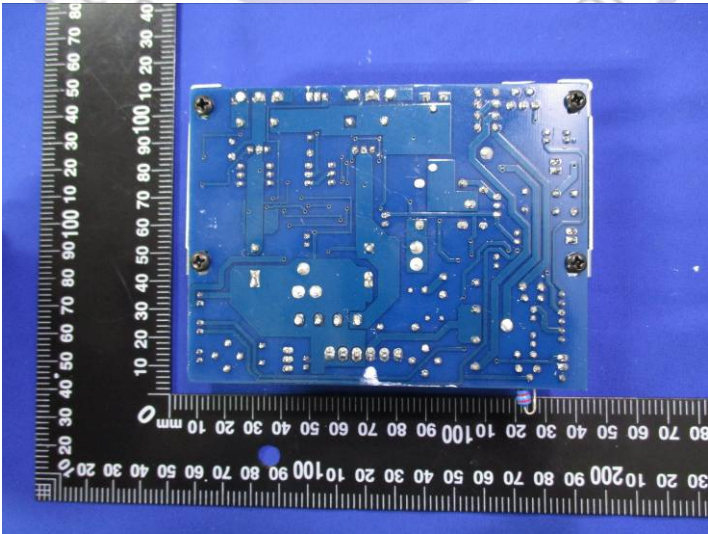
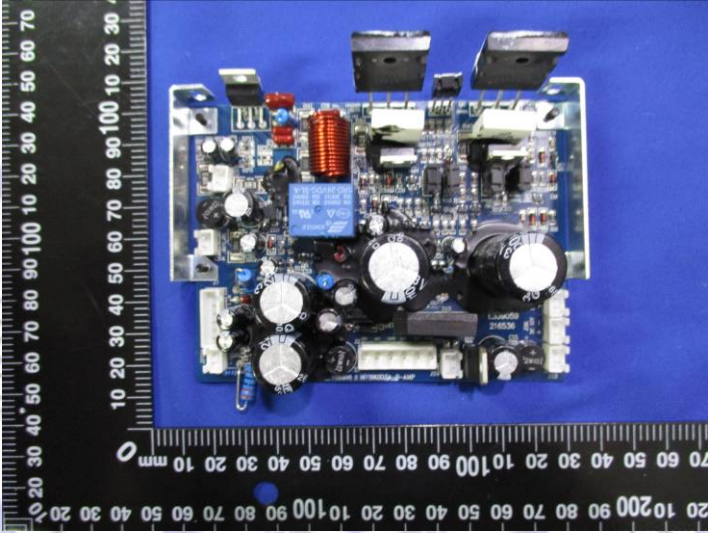
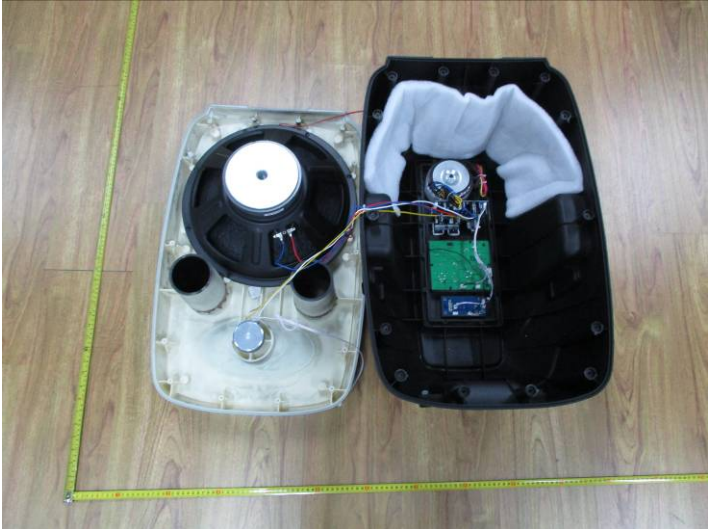

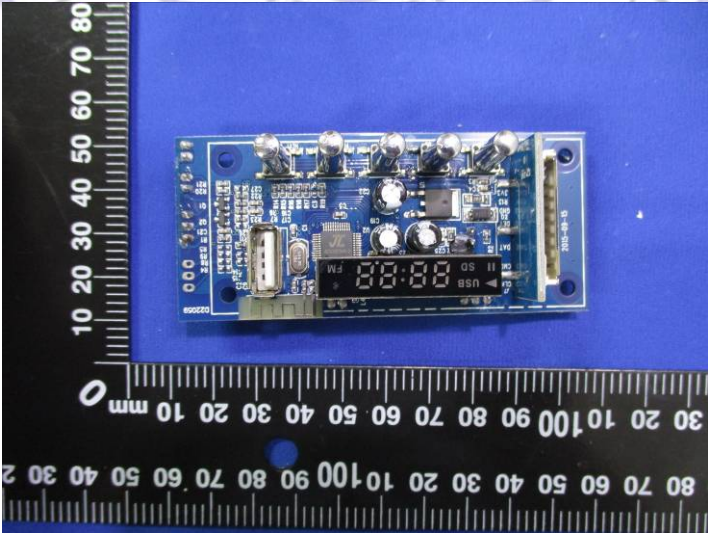
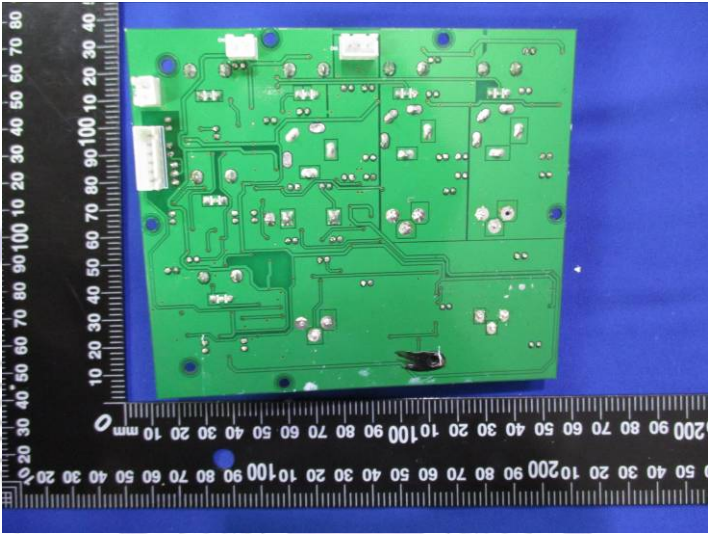
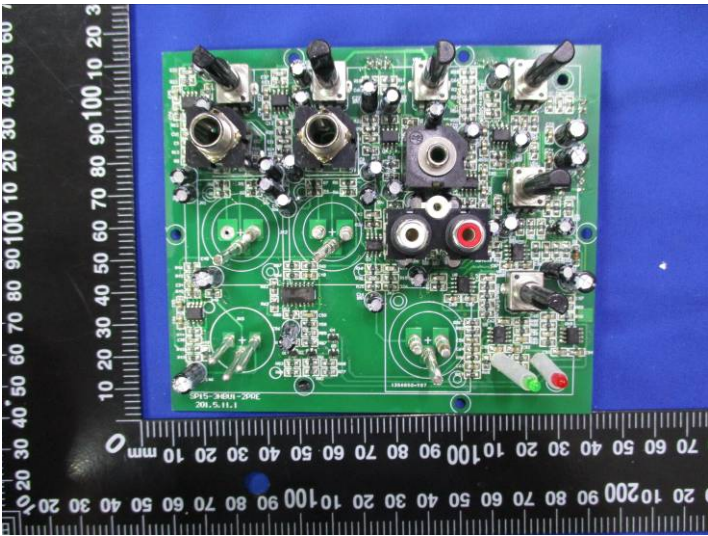

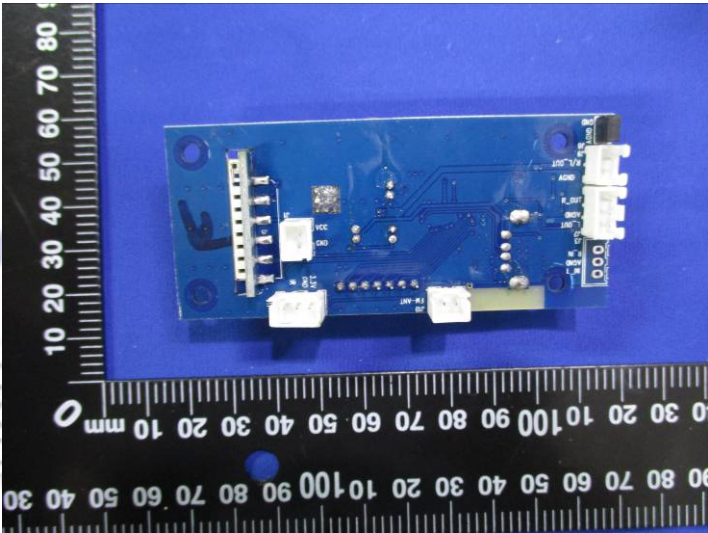
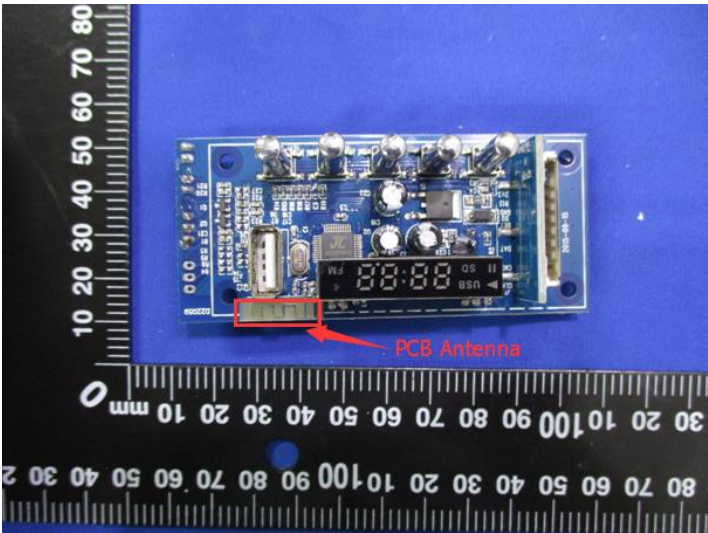

.....End of Report.....

