

# LA66701 Module User Manual

## 1. Introduction

### 1.1 Overview

The LA66701 is a Leedarson-developed universal Wi-Fi and Bluetooth SMART (BLE) combo module. It uses the Espressif Inc. ESP32-C3 System in Package that integrates an embedded 4MB flash.



Figure 1.1. LA02301 Module

The LA02301 module is designed for a variety of IOT products such as Power Drivers, Sensors, Plugs, Lighting, Switches, etc.



Plug

Switch

Sensor

Down Light

Power Driver

Figure 1.2. Product Application

### 1.2 Key features

- Embedded a RISC-V 32 bit MCU, with clock up to 160MHz
- Data Memory: 4MB internal Flash and 384KB internal ROM
- Power supply voltage: 3.0V~3.6V
- Operating temperature: -40~105 Deg-C
- Frequency of crystal oscillator: 40MHz
- Operating frequency: 2400~2483.5MHz
- Support WIFI 802.11b/g/n up to 150Mbps
- Compliant with Bluetooth LE specifications
- Wi-Fi 802.11 b/g/n and BLE can't transmission simultaneous

### 1.3 Block Diagram

The LA02301 module is a highly-integrated, high-performance system with all the hardware components needed to enable 2.4GHz wireless connectivity and support Wi-Fi and BLE protocols.

Built around the ESP32-U4WDH Wireless SoC, the LA02301 includes a built-in PCB trace antenna, supply decoupling and filtering components, a 40MHz reference crystal, a 32.768KHz crystal, and an RF shield. A general block diagram of the module is shown as below.

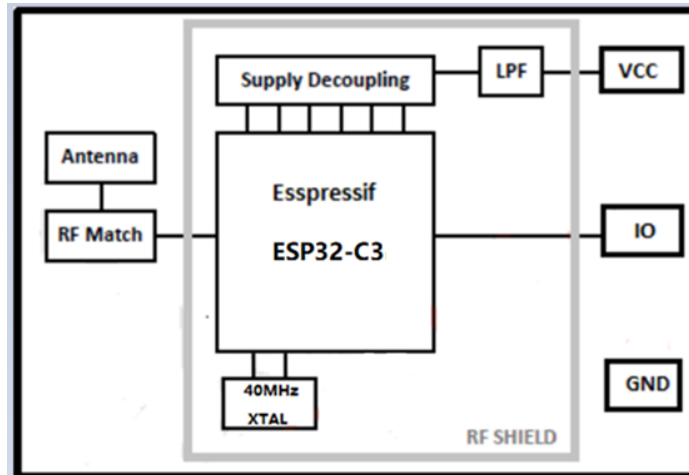

Figure 1.3. LA66701 Block Diagram

## 1.4 Power Supply

The LA66701 requires a single nominal supply level of 3.3V. All the necessary decoupling and filtering components are included in the module. The supply voltage noise tolerance of the module should be less than 100mVpp and the supply current should be more than 500mA.

## 1.5 Module Certification Information

Table 1.1. Module Certification Information

| Module  | Certification Type | Certification Information |
|---------|--------------------|---------------------------|
| LA66701 | FCC                | 2AB2Q-LA66701             |
|         | IC                 | 10256A-LA66701            |

## 2. Electrical characteristics

### 2.1 Absolute maximum ratings

Stresses above those listed below may cause permanent damage to the device. This is a stress rating only and functional operation of the devices at those or any conditions above those indicated in the operation listing of this specification is not implied. Exposure to maximum rating conditions for extended periods may affect device reliability.

Table 2.1. Absolute maximum ratings

| Symbol | Parameter    | Min. | Max. | Units |
|--------|--------------|------|------|-------|
| VCC    | Power Supply | -0.3 | +3.6 | V     |

|                     |                            |      |      |       |
|---------------------|----------------------------|------|------|-------|
| GND                 | Ground of Module           |      | 0    | V     |
| VIO                 | Voltage of Module IO       | -0.3 | +3.6 | V     |
| Storage temperature |                            | -40  | +105 | Deg-C |
| MSL                 | Moisture Sensitivity Level | 3    |      |       |
| ESD HBM             | Human Body Mode            |      | ±2   | KV    |
| ESD CDM             | Charge Device Mode         |      | ±1   | V     |

## 2.2 General Operating Conditions

This table specifies the general operating temperature range and supply voltage range for all supplies, the minimum and maximum values of all other tables are specified over this operating range, unless otherwise noted.

Table 2.2. General Operating Conditions

| Symbol      | Parameter                           | Min. | Typ. | Max. | Units |
|-------------|-------------------------------------|------|------|------|-------|
| VCC         | Supply voltage, normal              | 3.0  | 3.3  | 3.6  | V     |
| TA          | Operation temperature <sup>1</sup>  | -40  | 25   | 105  | Deg-C |
| ICC peak    | Supply Current Peak <sup>2</sup>    | -    | 380  | -    | mA    |
| ICC average | Supply Current average <sup>2</sup> | -    | 200  | -    | mA    |

Note:

- It refers in particular to the surface temperature on components of ESP32-C3H4 when the module is working.  
if the surface temperature of components is above 105°C, the RF parameters will be worse.
- It is measured when the module runs the WIFI RF test Firmware @25°C ambient temperature, it is provided here for reference only.

## 2.3 DC Specifications

Unless otherwise indicated, typical conditions are: VCC=3.3V,TA=25 Deg-C.

Table 2.3. DC Specifications

| Symbol           | Parameter(condition)                  | Min.     | Typ. | Max.     | Units |
|------------------|---------------------------------------|----------|------|----------|-------|
| VIH              | Input high voltage                    | 0.75xVCC | -    | VCC      | V     |
| VIL              | Input low voltage                     | GND      | -    | 0.25xVCC | V     |
| VOH              | Output high voltage                   | 0.8xVCC  | -    | -        | V     |
| VOL              | Output low voltage                    | -        | -    | 0.1xVCC  | V     |
| IOH              | Output high current                   | -        | 40   | -        | mA    |
| IOL              | Output low current                    | -        | 28   | -        | mA    |
| RPU              | Pull-up resistance                    | -        | 45   | -        | kΩ    |
| RPD              | Pull-down resistance                  | -        | 45   | -        | kΩ    |
| ITX 802.11b peak | Transmit 11b DSSS 1Mbps Pout=+19.5dBm | -        | 380  |          | mA    |

|  |   |   |     |   |    |
|--|---|---|-----|---|----|
| ITX 802.11b average  | Transmit 11b DSSS 1Mbps Pout=+19.5dBm   | - | 170 | - | mA |
| ITX 802.11b peak   | Transmit 11b DSSS 11Mbps Pout=+19.5dBm  | - | 380 | - | mA |
| ITX 802.11b average  | Transmit 11b DSSS 11Mbps Pout=+19.5dBm  | - | 170 | - | mA |
| ITX 802.11g peak   | Transmit 11g OFDM 6Mbps Pout=+18.5dBm   | - | 340 | - | mA |
| ITX 802.11g average  | Transmit 11g OFDM 6Mbps Pout=+18.5dBm   | - | 160 | - | mA |
| ITX 802.11g peak   | Transmit 11g OFDM 54Mbps Pout=+16.5 dBm | - | 300 | - | mA |
| ITX 802.11g average  | Transmit 11g OFDM 54Mbps Pout=+16.5 dBm | - | 145 | - | mA |
| ITX 802.11n peak   | Transmit 11n OFDM MCS0 Pout=+17.5 dBm   | - | 330 | - | mA |
| ITX 802.11n average  | Transmit 11n OFDM MCS0 Pout=+17.5 dBm   | - | 155 | - | mA |
| ITX 802.11n peak   | Transmit 11n OFDM MCS7 Pout=+16.5 dBm   | - | 290 | - | mA |
| ITX 802.11n average  | Transmit 11n OFDM MCS7 Pout=+16.5 dBm   | - | 145 | - | mA |
| IRX 802.11b/g/n  | Rx average current                      | - | 80  | - | mA |
| ITX BLE  | Pout=16 dBm                             | - | 260 | - | mA |
| ITX BLE average  | Pout=16 dBm                             | - | 200 | - | mA |
| IRX BLE  | Rx average current                      | - | 80  | - | mA |
| Note:<br>The current is measured with the module running the RF test Firmware, it is provided here for reference only. |   |   |     |   |    |

## 2.4 RF Specifications

Unless otherwise indicated, typical conditions are: VCC=3.3V TA=25 Deg-C.

Table 2.4. Wi-Fi Specifications

| Symbol   | Description                              | Min. | Typ.  | Max.   | Units |
|----------|--|------|-------|--------|-------|
| Fop      | Operating frequencies                    | 2400 | -     | 2483.5 | MHz   |
| PRF11b   | 11b DSSS 1Mbps output power              | -    | 19.5  | -      | dBm   |
|          | 11b DSSS 11Mbps output power             | -    | 19.5  | -      | dBm   |
| PRF11g   | 11g OFDM 6Mbps output power              | -    | 18.5  | -      | dBm   |
|          | 11g OFDM 54Mbps output power             | -    | 16.5  | -      | dBm   |
| PRF11n   | 11n OFDM HT20 MCS0 output power          | -    | 17.5  | -      | dBm   |
|          | 11n OFDM HT20 MCS7 output power          | -    | 16.5  | -      | dBm   |
|          | 11n OFDM HT40 MCS0 output power          | -    | 17.5  | -      | dBm   |
|          | 11n OFDM HT40 MCS7 output power          | -    | 15.5  | -      | dBm   |
| PSENS11b | Receiver sensitivity @11b DSSS 1Mbps     | -    | -97   | -      | dBm   |
|          | Maximum receiving level @11b DSSS 1Mbps  | -    | 5     | -      | dBm   |
|          | Receiver sensitivity @11b DSSS 11Mbps    | -    | -88   | -      | dBm   |
|          | Maximum receiving level @11b DSSS 11Mbps | -    | 5     | -      | dBm   |
| PSENS11g | Receiver sensitivity @11g OFDM 6Mbps     | -    | -92.5 | -      | dBm   |
|          | Maximum receiving level @11g OFDM 6Mbps  | -    | 5     | -      | dBm   |

|          |   |   |     |   |     |
|----------|---|---|-----|---|-----|
|          | Receiver sensitivity @11g OFDM 54Mbps       | - | -76 | - | dBm |
|          | Maximum receiving level @11g OFDM 54Mbps    | - | 0   | - | dBm |
| PSENS11n | Receiver sensitivity @11n OFDM HT20 MCS0    | - | -92 | - | dBm |
|          | Maximum receiving level @11n OFDM HT20 MCS0 | - | 5   | - | dBm |
|          | Receiver sensitivity @11n OFDM HT20 MCS7    | - | -74 | - | dBm |
|          | Maximum receiving level @11n OFDM HT20 MCS7 | - | 0   | - | dBm |
|          | Receiver sensitivity @11n OFDM HT40 MCS0    | - | -89 | - | dBm |
|          | Maximum receiving level @11n OFDM HT40 MCS0 | - | 5   | - | dBm |
|          | Receiver sensitivity @11n OFDM HT40 MCS7    | - | -71 | - | dBm |
|          | Maximum receiving level @11n OFDM HT40 MCS7 | - | 0   | - | dBm |

Table 2.5. BLE Specifications

| Symbol  | Description                | Min. | Typ. | Max.   | Units |
|---------|----------------------------|------|------|--------|-------|
| Fop     | Operating frequencies      | 2400 | -    | 2483.5 | MHz   |
| PRFLE   | LE Output Power            | -    | 16   | -      | dBm   |
|         | LE Out Power Control range | -27  | 24   | 16     | dB    |
|         | LE Out Power Control step  | -    | -    | -      | dB    |
| PSENSLE | LE Receiver sensitivity    | -    | -96  | -      | dBm   |
|         | LE Maximum receiving level | -    | 0    | -      | dBm   |

### 3. Pin Definition

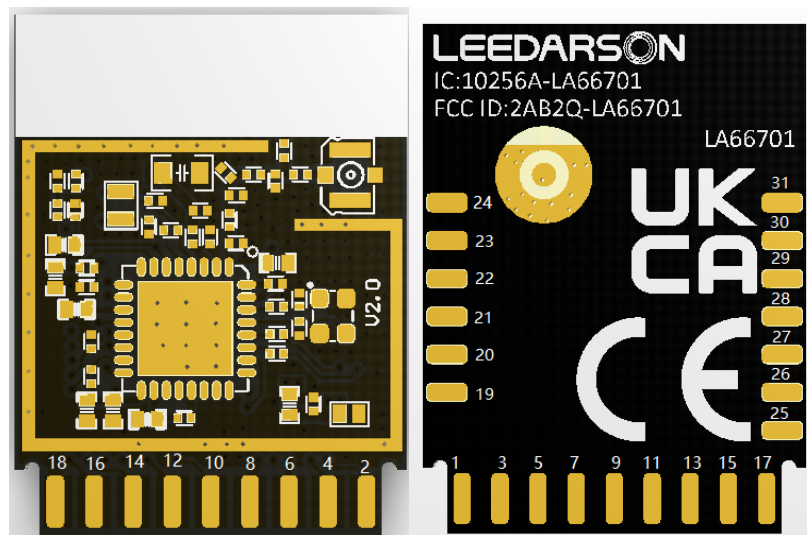

Figure 3.1. Pin of module

Table 3.1. pin definition

| Module No   | Pin of IC         | Pin Definition | Pin Function Description                                      | Direction |
|-------------|-------------------|----------------|---|-----------|
| 1           | 2,3,7,11,17,31,32 | VCC            | Power Supply  | --        |
| 2/20        | 27                | RX0            | FACTORY_UART_RX data in (RX)                                  | I         |
| 3           | --                | GND            | ground of module  | --        |
| 4/19        | 28                | TX0            | FACTORY_UART_TX data out (TX)                                 | O         |
| 5           | 12                | IO1            | GPIO  | I/O       |
| 6/29        | 25                | RX1            | HOST_UART_TX (data in to ESP32) , need an external pull up    | I         |
| 7           | 9                 | IO2            | GPIO  | I/O       |
| 8/28        | 26                | TX1            | HOST_UART_RX (data out from ESP32) , need an external pull up | O         |
| 9           | 10                | IO3            | GPIO  | I/O       |
| 10/26       | 14                | PH             | GPIO and Dowload Control                                      | I/O       |
| 11          | 13                | IO4            | GPIO  | I/O       |
| 12/27       | 5                 | I2C_SCL        | GPIO /I2C_SCL   | I/O       |
| 13          | 16                | IO5            | P GPIO  | I/O       |
| 14/25       | 7                 | /Reset         | Reset, Low Active   | I         |
| 15          | 15                | PL             | GPIO and Dowload Control                                      | I/O       |
| 16/30       | 4                 | I2C_SDA        | GPIO /I2C_SDA   | I/O       |
| 17          | 8                 | ADC            | Analog-to-Digital Converter                                   | I         |
| 18/23/24/31 | --                | GND            | ground of module  | --        |
| Note:       |                   |                |   |           |

## 4. Package Specifications

### 4.1 Dimension

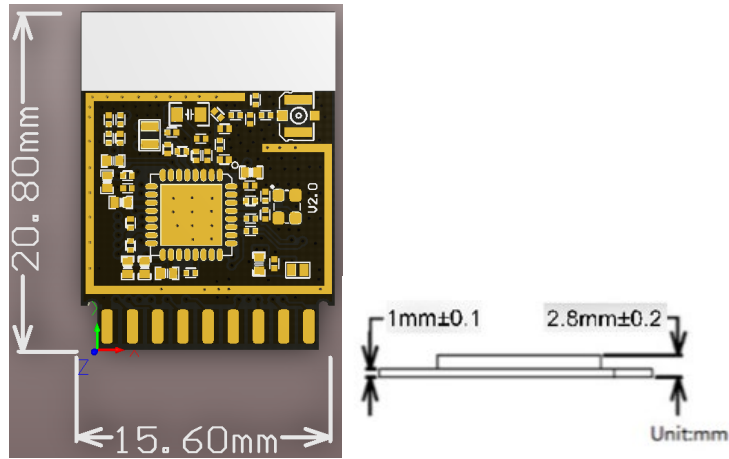
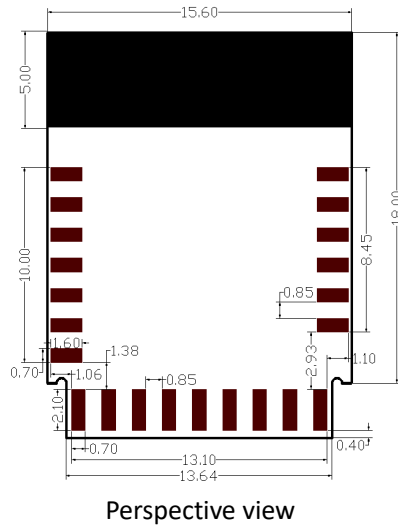

Figure 4.1. Module Dimensions (Unit: mm)

## 4.2 PCB Pads Information



Perspective view

Figure 4.2. Pad Size (Unit: mm)

Note:

1. Shaded part is Antenna Trace.
2. The sizes of pads on the component side are the same to the opposite side.

## 4.3 Plug-in Land pattern example

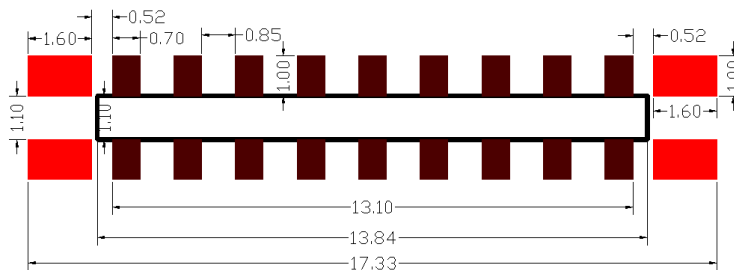

Figure 4.3. Plug-in PCB Land Pattern (Unit: mm)

Note:

Please see below lay-out:

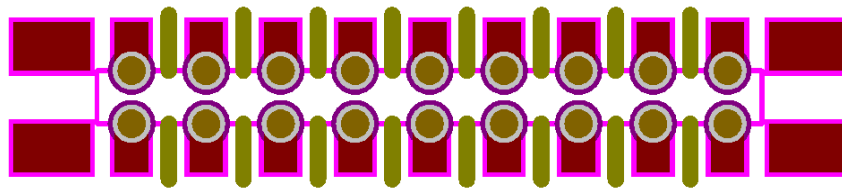

Figure 4.4. Plug-in PCB Land Pattern (Unit: mm)

#### 4.4 SMD Land pattern example

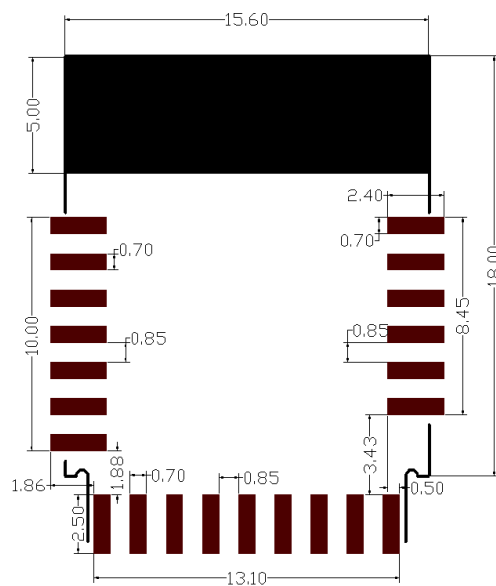

Figure 4.5. SMD PCB Land Pattern (Unit: mm)

Note:

Shaded part is Antenna Trace.

### 5. Soldering Recommendations

Refer to below information for SMT temperature settings. Note that the number of times of reflow should not above 2 times.

Table 5.1. SMT temperature setting

| Set points(°C)                  |     |     |     |     |     |     |     |     |     |     |
|---------------------------------|-----|-----|-----|-----|-----|-----|-----|-----|-----|-----|
| Zone                            | 1   | 2   | 3   | 4   | 5   | 6   | 7   | 8   | 9   | 10  |
| Top                             | 140 | 180 | 190 | 180 | 180 | 190 | 245 | 260 | 265 | 210 |
| Bottom                          | 140 | 180 | 190 | 180 | 180 | 190 | 245 | 260 | 265 | 210 |
| Conveyor Speed (cm/min) : 130.0 |     |     |     |     |     |     |     |     |     |     |



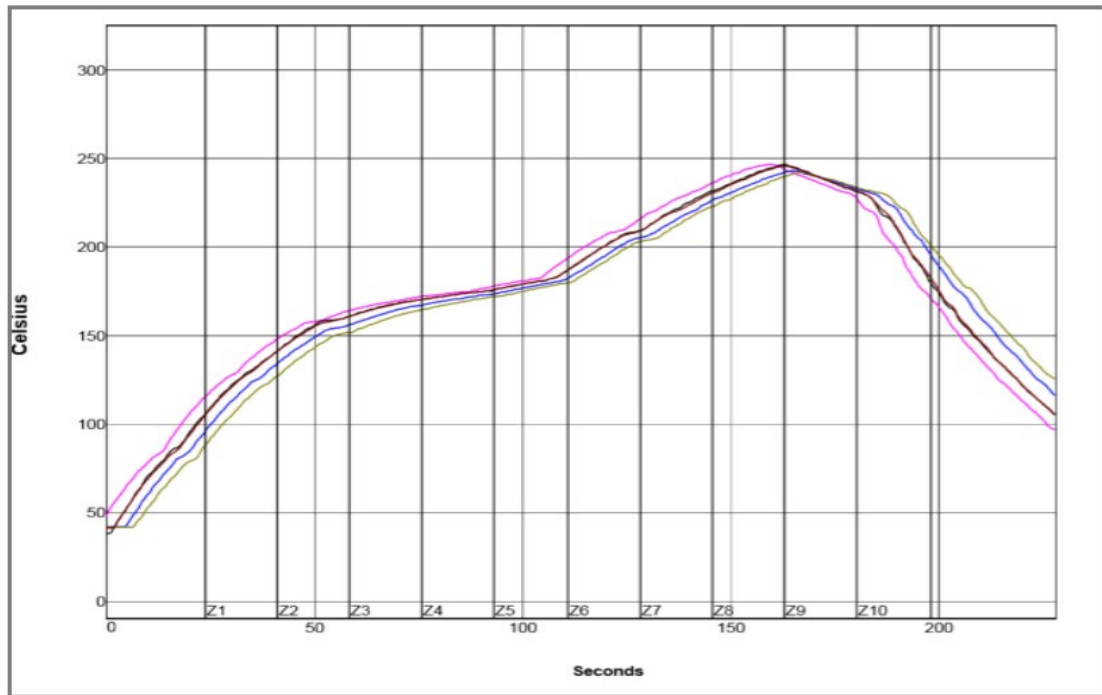

Figure 5.1. SMT temperature setting curve

## 6. Declaration FCC Statement

This equipment has been tested and found to comply with the limits for a Class B digital device, pursuant to part 15 of the FCC rules. These limits are designed to provide reasonable protection against harmful interference in a residential installation. This equipment generates, uses and can radiate radio frequency energy and, if not installed and used in accordance with the instructions, may cause harmful interference to radio communications. However, there is no guarantee that interference will not occur in a particular installation. If this equipment does cause harmful interference to radio or television reception, which can be determined by turning the equipment off and on, the user is encouraged to try to correct the interference by one or more of the following measures:

- Reorient or relocate the receiving antenna.
- Increase the separation between the equipment and receiver.
- Connect the equipment into an outlet on a circuit different from that to which the receiver is connected.
- Consult the dealer or an experienced radio/TV technician for help.

This equipment complies with Part 15 of the FCC Rules. Operation is subject to the following two conditions:

- (1) This device may not cause harmful interference, and
- (2) This device must accept any interference received, including interference that may cause undesired operation.

Any changes or modifications not expressly approved by the party responsible for compliance could void the user's authority to operate the equipment.

## 2.2

This module has been assessed against the following FCC rule parts: CFR 47 FCC Part 15 C (15.247, DTS). It is applicable to the modular transmitter

## 2.3

This radio transmitter 2AB2Q-LA66701 has been approved by Federal Communications Commission to operate with the antenna types listed below, with the maximum permissible gain indicated. Antenna types not included in this list that have a gain greater than the maximum gain indicated for any type listed are strictly prohibited for use with this device.

The concrete contents to check are the following three points.

- 1) Must use a PCB antenna with gain not exceeding those shown in the table below.
- 2) Should be installed so that the end user cannot modify the antenna
- 3) Feed line should be designed in 50ohm

Fine-tuning of return loss etc. can be performed using a matching network.

The antenna shall not be accessible for modification or change by the end user

## 2.4

The module complies with FCC Part 15.247 and apply for Single module approval.

## 2.5

Trace antenna designs: Not applicable.

The device must be professionally installed

The intended use is generally not for the general public. It is generally for industry/commercial use.

The connector is within the transmitter enclosure and can only be accessed by disassembly of the transmitter which is not normally required. the user has no access to the connector.

Installation must be controlled. Installation requires special training

## 2.6

This equipment complies with FCC radiation exposure limits set forth for an uncontrolled environment. This equipment should be installed and operated with a minimum distance of 20cm between the radiator & your body. This transmitter must not be co-located or operating in conjunction with any other antenna or transmitter.

## 2.7

Antenna type and antenna gain:

BLE Antenna

| Antenna | Frequency (MHz) | Antenna Type | MAX Antenna Gain (dBi) |
|---------|-----------------|--------------|------------------------|
| 1       | 2402-2480       | PCB Antenna  | 4                      |

## 2.4G WIFI Antenna

| Antenna | Frequency (MHz) | Antenna Type | MAX Antenna Gain (dBi) |
|---------|-----------------|--------------|------------------------|
| 1       | 2412-2462       | PCB Antenna  | 4                      |

### 2.8

Please notice that if the FCC identification number is not visible when the module is installed inside another device, then the outside of the device into which the module is installed must also display a label referring to the enclosed module. This exterior label can use wording such as "Contains FCC ID: 2AB2Q-LA66701"; any similar wording that expresses the same meaning may be used.

### 2.9

Testing of the host product with all the transmitters installed – referred to as the composite investigation test- is recommended, to verify that the host product meets all the applicable FCC rules. The radio spectrum is to be investigated with all the transmitters in the final host product functioning to determine that no emissions exceed the highest limit permitted for any one individual transmitter as required by Section 2.947(f). The host manufacturer is responsible to ensure that when their product operates as intended it does not have any emissions present that are out of compliance that were not present when the transmitters were tested individually.

If the modular transmitter has been fully tested by the module grantee on the required number of channels, modulation types, and modes, it should not be necessary for the host installer to re-test all the available transmitter modes or settings. It is recommended that the host product manufacturer, installing the modular transmitter, perform some investigative measurements to confirm that the resulting composite system does not exceed the spurious emissions limits or band edge limits (e.g., where a different antenna may be causing additional emissions).

The testing should check for emissions that may occur due to the intermixing of emissions with the other transmitters, digital circuitry, or due to physical properties of the host product (enclosure). This investigation is especially important when integrating multiple modular transmitters where the certification is based on testing each of them in a stand-alone configuration.

### 2.10

Any company of the host device which installs this modular should perform the test of radiated & conducted emission and spurious emission etc. according to FCC Part 15C: 15.247 and 15.209 & 15.207, 15B class B requirement, only if the test result complies with FCC part 15C: 15.247 and 15.209 & 15.207, 15B class B requirement. Then the host can be sold legally.

The host product manufacturer is responsible for compliance with any other FCC rules that apply to the host not covered by the modular transmitter grant of certification. If the grantee markets their product as being Part 15 Subpart B compliant (when it also

contains unintentional-radiator digital circuitry), then the grantee shall provide a notice stating that the final host product still requires Part 15 Subpart B compliance testing with the modular transmitter installed.

#### 2.11

The host manufacture is recommended to use D04 Module Integration Guide recommending as "best practice" RF design engineering testing and evaluation in case non-linear interactions generate additional non-compliant limits due to module placement to host components or properties.

#### 2.12

This module is stand-alone modular. If the end product will involve the Multiple simultaneously transmitting condition or different operational conditions for a stand-alone modular transmitter in a host, host manufacturer have to consult with module manufacturer for the installation method in end system.

## Canada Statement

This device complies with Industry Canada's license-exempt RSSs. Operation is subject to the following two conditions:

(1) This device may not cause interference; and

(2) This device must accept any interference, including interference that may cause undesired operation of the device.

Le présent appareil est conforme aux CNR d'Industrie Canada applicables aux appareils radio exempts de licence.

L'exploitation est autorisée aux deux conditions suivantes :

(1) l'appareil ne doit pas produire de brouillage;

(2) l'utilisateur de l'appareil doit accepter tout brouillage radioélectrique subi, même si le brouillage est susceptible d'en compromettre le fonctionnement.

Please notice that if the ISED certification number is not visible when the module is installed inside another device, then the outside of the device into which the module is installed must also display a label referring to the enclosed module. This exterior label can use wording such as the following: "Contains IC:10256A-LA66701" any similar wording that expresses the same meaning may be used.

l'appareil hôte doit porter une étiquette donnant le numéro de certification du module d'Industrie Canada, précédé des mots « Contient un module d'émission », du mot « IC:10256A-LA66701 » ou d'une formulation similaire exprimant le même sens, comme suit

The device meets the exemption from the routine evaluation limits in section 2.5 of RSS 102 and compliance with RSS-102 RF exposure, users can obtain Canadian information on RF exposure and compliance.

Le dispositif rencontre l'exemption des limites courantes d'évaluation dans la section 2.5 de RSS 102 et la conformité à l'exposition de RSS-102 RF, utilisateurs peut obtenir l'information canadienne sur l'exposition et la conformité de rf.

This transmitter must not be co-located or operating in conjunction with any other antenna or transmitter. This equipment should be installed and operated with a minimum distance of 20 centimeters between the radiator and your body.

Cet émetteur ne doit pas être Co-placé ou ne fonctionnant en même temps qu'aucune autre antenne ou émetteur. Cet équipement devrait être installé et actionné avec une distance minimum de 20 centimètres entre le radiateur et votre corps.

This radio transmitter 10256A-LA66701 has been approved by Innovation, Science and Economic Development Canada to operate with the antenna types listed below, with the maximum permissible gain indicated. Antenna types not included in this list that have a gain greater than the maximum gain

Le présent émetteur radio 10256A-LA66701 a été approuvé par Innovation, Sciences et Développement économique Canada pour fonctionner avec les types d'antenne énumérés ci-dessous et ayant un gain admissible maximal. Les types d'antenne non inclus dans cette liste, et dont le gain est supérieur au gain maximal indiqué pour tout type figurant sur la liste, sont strictement interdits pour l'exploitation de l'émetteur.

The concrete contents to check are the following three points.

1 ) Must use a PCB antenna with gain not exceeding those shown in the table below.

2 ) Should be installed so that the end user cannot modify the antenna

3 ) Feed line should be designed in 50ohm

Fine tuning of return loss etc. can be performed using a matching network.

Le contenu concret à vérifier sont les trois points suivants.

1) doit utiliser une antenne PCB avec un gain ne dépassant pas ceux indiqués dans le tableau ci-dessous.

2) devrait être installé de sorte que l'utilisateur ne puisse pas modifier l'antenne

3) la ligne d'alimentation devrait être conçue dans 50ohm

Le réglage fin de la perte de retour, etc. peut être effectué en utilisant un réseau correspondant.

Antenna type and antenna gain:

---

BLE Antenna

| Antenna | Frequency (MHz) | Antenna Type | MAX Antenna Gain (dBi) |
|---------|-----------------|--------------|------------------------|
| 1       | 2402-2480       | PCB Antenna  | 4                      |

2.4G WIFI Antenna

| Antenna | Frequency (MHz) | Antenna Type | MAX Antenna Gain (dBi) |
|---------|-----------------|--------------|------------------------|
| 1       | 2412-2462       | PCB Antenna  | 4                      |

---

## Notice to OEM integrator

Must use the device only in host devices that meet the FCC/ISED RF exposure category of mobile, which means the device is installed and used at distances of at least 20cm from persons.

This transmitter must not be co-located or operating in conjunction with any other antenna or transmitter.

The end user manual shall include FCC Part 15 /ISED RSS GEN compliance statements related to the transmitter as show in this manual(FCC/Canada statement).

Host manufacturer is responsible for compliance of the host system with module installed with all other applicable requirements for the system such as Part 15 B, ICES 003.

Host manufacturer is strongly recommended to confirm compliance with FCC/ISED requirements for the transmitter when the module is installed in the host.

The use condition limitations extend to professional users, then instructions must state that this information also extends to the host manufacturer's instruction manual.

This module is stand-alone modular. If the end product will involve Multiple simultaneously transmitting condition or different operational conditions for a stand-alone modular transmitter in a host, host manufacturer has to consult with module manufacturer for the installation method in the end system.

Any company of the host device which install this modular should perform the test of radiated & conducted emission and spurious emission etc. according to FCC Part 15C: 15.247 and 15.209 & 15.207, 15B class B requirement, only if the test result comply with FCC part 15C: 15.247 and 15.209 & 15.207,15B class B requirement. Then the host can be sold legally.

This modular transmitter is only FCC authorized for the specific rule parts ( 47CFR Part 15.247) listed on the grant, and that the host product manufacturer is responsible for compliance to any other FCC rules that apply to the host not covered by the modular transmitter grant of certification.

Host manufacturer is strongly recommended to confirm compliance with FCC/ISED requirements for the transmitter when the module is installed in the host.

Must have on the host device a label showing Contains FCC ID: 2AB2Q-LA66701 or IC:10256A-LA66701

Both FCC ID and IC ID are not to be placed on the host at the same time and only hosts going into the US can use the FCC ID and only hosts going into Canada can use the IC ID.

l'hôte doit utiliser l'instrument uniquement dans des dispositifs qui répondent à la fcc / (catégorie d'exposition rf mobile, ce qui signifie le dispositif est installé et utilisé à une distance d'au moins 20 cm de personnes.

le manuel de l'utilisateur final doit inclure la partie 15 / (fac rss gen déclarations de conformité relatives à l'émetteur que de montrer dans ce manuel.

le fabricant est responsable de la conformité de l'hôte, le système d'accueil avec le module installé avec toutes les autres exigences applicables du système comme la partie 15 b, ices - 003.

accueillir le fabricant est fortement recommandé de confirmer la conformité avec les exigences de la fcc / (émetteur lorsque le module est installé dans l'hôte.

le dispositif d'accueil doivent avoir une étiquette indiquant contient FCC ID: 2AB2Q-LA66701, IC:10256A-LA66701

Doit avoir sur l'appareil hôte une étiquette indiquant Contient l'ID FCC : 2AB2Q-LA66701 ou IC :10256A-LA66701 L'ID FCC et l'ID IC ne doivent pas être placés sur l'hôte en même temps et seuls les hôtes se rendant aux États-Unis peuvent utiliser l'ID FCC et seuls les hôtes se rendant au Canada peuvent utiliser l'ID IC.