



## Overview

The Amazon A2B device is used as a tracking device for the GoCart containers in Amazon middle mile logistics. It uses various RF technologies like RFID and 2.4GHz to determine the positions of the tracked asset. Besides that it provides additional functionalities like red tagging of the asset, temperature and orientation monitoring. The device has been designed to be maintenance-less and should be able to operate for a period of at least 5 years.

## Key Features

- Supports passive RFID inlay tag.
- Supports 2.4GHz advertising in 3 formats: Eddystone TLM, Eddystone UID and Amazon A2B format.
- Battery lifetime of 5 years using a non-rechargeable battery.
  - Battery options: 1x Li-SOCI2 3.6V battery (compliant with the safety regulations defined by IEC 60086-4, UL 1642, UL 2054, UN38.3 or equivalent).
- Integrates a RGB LED, a multifunctional Front Button and extra GPIOs for connection with external sensors or IOs.

## Specifications

This section provides technical details of the Amazon A2B device.

### Key Components

- Based on the MCU nRF52833
- LIS2DW accelerometer.

### Electrical Parameters

Parameter	Value
Battery power supply	1x Li-SOCI2 3.6V battery
Power Consumption (Battery)	Up to 135mA @ 3.6V

Operating temperature	-30°C ~ +85°C
Current consumption in deep sleep	2.5uA

### Mechanical Parameters

Parameter	Value
Dimensions	Without the bracket: Max. 174.8 x 56.2 x 25.7 mm (6.88 x 2.21 x 1.01 in) With the bracket: Max. 200.8 x 113.1 x 33.1 mm (7.91 x 4.45 x 1.30 in)
Weight	Without the bracket: 120g With the bracket: 370g
Front Button	Covered by a TPE that allows flexible press and pass-through of the LED light

## User Interface

### Button

Supports actions of short and long press. Functions of the multi-purpose button are described in the sections below.

- Short press - device status check. The LEDs will indicate that the device is running. Green LED will blink when remaining battery capacity is sufficient. Red LED will blink when the remaining battery capacity is low.
- Long press - enable maintenance request. The RED LED, if enabled in site configuration, will indicate the device is requiring maintenance. A repeated Long press will clear the maintenance request.

### LEDs

The device contains Red, Green and Blue LED indicators. Meanings of the multi-purpose LEDs are described in the sections below.

- Normal operation mode
  - After a short press to check the device status and battery capacity is sufficient

- Green: 2000 ms BLINK (1:10 duty cycle).  
Blinking will stay for 30 s.
- After a short press to check the device status and battery capacity is low
  - Red: 2000 ms BLINK (1:10 duty cycle).  
Blinking will stay for 30 s.
- After a long press to enable maintenance request
  - Red: 2000 ms BLINK (1:10 duty cycle).  
Blinking will stay for 5 min.

## Mounting Instructions

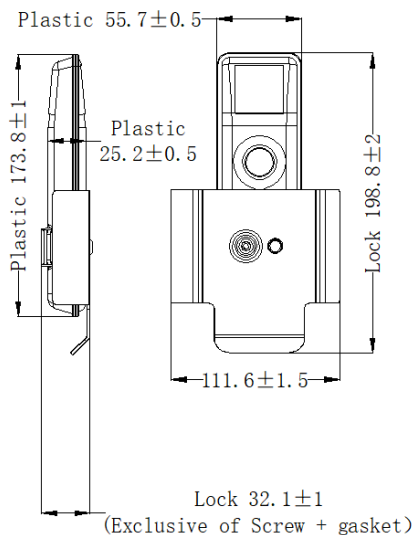
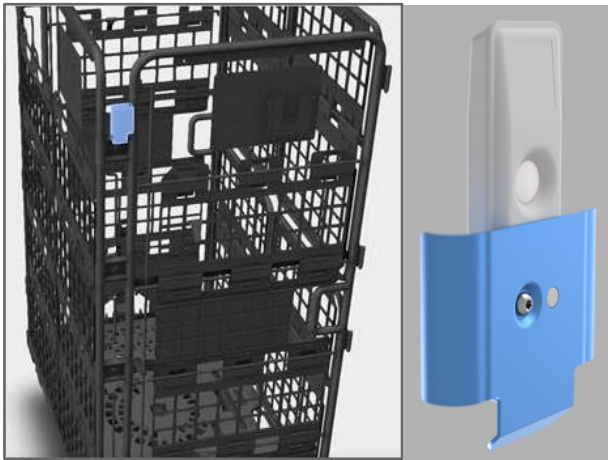

## Safety Instructions

### Battery Safety

This product contains Lithium Battery.

Do not open, disassemble, puncture, cut, bend, shred or heat the batteries. Dispose of all batteries in

accordance with applicable laws and regulations and do not dispose of batteries by throwing them into a fire.

### WARNINGS AND CAUTIONS FOR PRODUCTS USING BATTERIES:

- high or low extreme temperatures that a BATTERY can be subjected to during use, storage or transportation; and
- low air pressure at high altitude.
- disposal of a BATTERY into fire or a hot oven, or mechanically crushing or cutting of a BATTERY, that can result in an EXPLOSION;
- leaving a BATTERY in an extremely high temperature surrounding environment that can result in an EXPLOSION or the leakage of flammable liquid or gas; and
- a BATTERY subjected to extremely low air pressure that may result in an explosion or the leakage of flammable liquid or gas.
- BATTERY is not intend for replaceable.

## Compliance Information

Simplified declaration of conformity:

**CE** Hereby, **Amazon.com Services LLC** declares that the radio equipment type A2B Tag in compliance with Directive 2014/53/EU.

**UK CA** Hereby, **Amazon.com Services LLC** declares that the radio equipment type A2B Tag in compliance with Regulation 2017.

The full text of the declaration of conformity at loose leaf.

## Environmental Protection and disposal



Electrical or electronic devices which are no longer usable must be collected separately and disposed of via an environmentally friendly recycling facility (European Directive on Waste Electrical and Electronic Equipment). Use your country's specific return and collection systems when disposing of waste electrical or electronic devices.



Used batteries do not go in the household waste! Dispose of them at your local battery collection point.

## FCC Regulation

FCC Supplier's Declaration of Conformity

Brand name / model number: Amazon / A2B001-V1

Suppliers Name: Amazon.com Services LLC

Suppliers Address: 333 108th Ave NE, Bellevue 98004, Washington, U.S.A

Phone: 1-678-293-8382

E-mail: [lux14-reception@amazon.com](mailto:lux14-reception@amazon.com)

This device complies with Part 15 of the FCC Rules. Operation is subject to the following two conditions:

- (1) This device may not cause harmful interference.
- (2) This device must accept any interference received, including interference that may cause undesired operation.

Changes or modifications not expressly approved by the part responsible for compliance could void the user's authority to operate the equipment.

This equipment has been tested and found to comply with the limits for a Class B digital device, pursuant to part 15 of the FCC Rules. These limits are designed to provide reasonable protection against harmful interference in a residential installation. This equipment generates, uses and can radiate radio frequency energy and, if not installed and used in accordance with the instructions, may cause harmful interference to radio communications. However, there is no guarantee that interference will not occur in a particular installation. If this equipment does cause harmful interference to radio or television reception, which can be determined by turning the equipment off and on, the user is encouraged to try to correct the interference by one or more of the following measures:

- Reorient or relocate the receiving antenna.
- Increase the separation between the equipment and receiver.
- Connect the equipment into an outlet on a circuit different from that to which the receiver is connected.
- Consult the dealer or an experienced radio/TV technician for help.