



FCC PART 90 Test Report

Report Reference No......: **CTL1403250549-WF**

Compiled by

(position+printed name+signature)...: File administrators Jacky Chen

Name of the organization performing the tests

Test Engineer Tracy Qi

(position+printed name+signature)...:

Approved by

(position+printed name+signature)...: Manager Tracy Qi

Date of issue.....: Mar. 25, 2014

Testing Laboratory Name: **Shenzhen CTL Testing Technology Co., Ltd.**

Address.....: Floor 1-A, Baisha Technology Park, No.3011, Shahexi Road, Nanshan District, Shenzhen, China 518055

Applicant's name.....: **Lisheng (Fujian) Communications Co., Ltd.**

Address.....: 5#, Chongxiang St., Econ.&Tech. Area, Quanzhou, Fujian, China

Test specification:

Standard: **FCC Part 90: PRIVATE LAND MOBILE RADIO SERVICES**

TRF Originator.....: Shenzhen CTL Testing Technology Co., Ltd.

Master TRF.....: Dated 2011-01

Shenzhen CTL Testing Technology Co., Ltd. All rights reserved.

This publication may be reproduced in whole or in part for non-commercial purposes as long as the Shenzhen CTL Testing Technology Co., Ltd. is acknowledged as copyright owner and source of the material. Shenzhen CTL Testing Technology Co., Ltd. takes no responsibility for and will not assume liability for damages resulting from the reader's interpretation of the reproduced material due to its placement and context.

Test item description : Two-Way Radio/Transceiver

Trade Mark: LISHENG

Model/Type reference.....: LS-A8 UHF

Modulation.....: FM

Channel Separation.....: 12.5KHz

Power Supply: DC 7.4V

Rated Power.....: 5W

Operating Frequency Range: From 450 MHz to 512 MHz

FCC ID.....: 2AB2FLS-A8-UHF

Result.....: **Positive**

TEST REPORT

Test Report No. :	CTL1403250549-WF	Mar. 25, 2014
		Date of issue

Equipment under Test : Two-Way Radio/Transceiver

Model /Type : LS-A8 UHF

Applicant : **Lisheng (Fujian) Communications Co., Ltd.**

Address : 5#, Chongxiang St., Econ.&Tech. Area, Quanzhou, Fujian, China

Manufacture : **Lisheng (Fujian) Communications Co., Ltd.**

Address : 5#, Chongxiang St., Econ.&Tech. Area, Quanzhou, Fujian, China

Test Result according to the standards on page 4:	Positive
--	-----------------

The test report merely corresponds to the test sample.
It is not permitted to copy extracts of these test result without the written permission of the test laboratory.



Contents

1.	<u>TEST STANDARDS</u>	4
2.	<u>SUMMARY</u>	5
2.1.	General Remarks	5
2.2.	Equipment Under Test	5
2.3.	Short description of the Equipment under Test (EUT)	5
2.4.	Short description of the Equipment under Test (EUT)	6
2.5.	EUT operation mode	6
2.6.	EUT configuration	6
2.7.	Related Submittal(s) / Grant (s)	6
2.8.	Modifications	6
2.9.	Note	6
3.	<u>TEST ENVIRONMENT</u>	7
3.1.	Address of the test laboratory	7
3.2.	Test Facility	7
3.3.	Environmental conditions	7
3.4.	Configuration of Tested System	7
3.5.	Statement of the measurement uncertainty	8
3.6.	Equipments Used during the Test	8
3.7.	General Technical Requirements and Summary of Test Results	8
4.	<u>TEST CONDITIONS AND RESULTS</u>	9
4.1.	Conducted Emissions Test	9
4.2.	Occupied Bandwidth and Emission Mask	12
4.3.	Radiated Spurious Emission Test	20
4.4.	Spurious Emission On Antenna Port	25
4.5.	Modulation Characteristics	34
4.6.	Frequency Stability Measurement	37
4.7.	Conducted Output Power	39
4.8.	Transmitter Frequency Behavior	43
5.	<u>TEST SETUP PHOTOS OF THE EUT</u>	45
6.	<u>EXTERNAL AND INTERNAL PHOTOS OF THE EUT</u>	47

1. TEST STANDARDS

The tests were performed according to following standards:

FCC Part 90: PRIVATE LAND MOBILE RADIO SERVICES

TIA/EIA 603-C-2004: Land Mobile FM or PM Communications Equipment Measurement and Performance Standards.

The device was tested to TIA/EIA 603-C-2004.

47 CFR FCC Part 15 Subpart B - Unintentional Radiators

FCC Part 2: FREQUENCY ALLOCATIONS AND RADIO TREATY MATTERS; GENERAL RULES AND REGULATIONS



2. SUMMARY

2.1. General Remarks

Date of receipt of test sample	:	Mar. 10, 2014
Testing commenced on	:	Mar. 10, 2014
Testing concluded on	:	Mar. 25, 2014

2.2. Equipment Under Test

Power supply system utilised

Power supply voltage	:	<input checked="" type="radio"/> 120V / 60 Hz	<input type="radio"/> 115V / 60Hz
		<input type="radio"/> 12 V DC	<input type="radio"/> 24 V DC
		<input checked="" type="radio"/> Other (specified in blank below)	

DC 7.4 V from adapter by AC 120V/60Hz

2.3. Short description of the Equipment under Test (EUT)

The Two-Way Radio/Transceiver, Model: LS-A8 UHF or the "EUT" as referred to in this report; more general information as follows, for more details, refer to the user's manual of the EUT.

Name of EUT	Two-Way Radio/Transceiver	
Model Number	LS-A8 UHF	
FCC ID	2AB2FLS-A8-UHF	
Rated Output Power	5 Watts(36.99dBm)	
Modulation Type	FM for Analog Voice	
	Analog	F3E for 12.5KHz Channel Separation
Channel Separation	Analog Voice	12.5KHz
Antenna Type	External	
Frequency Range	From 450 MHz to 512 MHz	
Maximum Output Power	Analog	4.71W for 12.5 KHz Channel Separation

Test frequency list

Frequency Range (MHz)	Modulation Type	Channel Separation (KHz)	Test Channel	Test Frequency (MHz)	
				TX	RX
	Analog/FM	12.5	A001	450.5000	450.5000
			A002	465.0000	465.0000
			A003	481.0000	481.0000
			A004	496.0000	496.0000
			A005	511.5000	511.5000

2.4. Short description of the Equipment under Test (EUT)

450-512MHz Two-Way Radio/Transceiver (LS-A8 UHF).

For more details, refer to the user's manual of the EUT.

Serial number: Prototype

2.5. EUT operation mode

The EUT has been tested under typical operating condition.

2.6. EUT configuration

The following peripheral devices and interface cables were connected during the measurement:

● - supplied by the manufacturer

○ - supplied by the lab

● Power Cable	Length (m) :	1.6m
	Shield :	No
	Detachable :	No
○ Multimeter	Manufacturer :	/
	Model No. :	/

2.7. Related Submittal(s) / Grant (s)

This submittal(s) (test report) is intended for FCC ID: 2AB2FLS-A8-UHF filing to comply with the FCC Part 90 Rules.

2.8. Modifications

No modifications were implemented to meet testing criteria.

2.9. Note

The EUT is a U frequency band (450-512MHz) Two-way Radio, The functions of the EUT listed as below:

	Test Standards	Reference Report
Radio	FCC Part 90	CTL1403250549-WF

3. TEST ENVIRONMENT

3.1. Address of the test laboratory

Shenzhen CTL Testing Technology Co., Ltd.
Floor 1-A, Baisha Technology Park, No. 3011, Shaheji Road, Nanshan, Shenzhen 518055 China

There is one 3m semi-anechoic chamber and two line conducted labs for final test. The Test Sites meet the requirements in documents ANSI C63.4 and CISPR 22/EN 55022 requirements.

3.2. Test Facility

The test facility is recognized, certified, or accredited by the following organizations:

IC Registration No.: 9618B

The 3m alternate test site of Shenzhen CTL Testing Technology Co., Ltd. EMC Laboratory has been registered by Certification and Engineer Bureau of Industry Canada for the performance of with Registration No.: 9618B on November 13, 2013.

FCC-Registration No.: 970318

Shenzhen CTL Testing Technology Co., Ltd. EMC Laboratory has been registered and fully described in a report filed with the (FCC) Federal Communications Commission. The acceptance letter from the FCC is maintained in our files. Registration 970318, December 19, 2013.

3.3. Environmental conditions

During the measurement the environmental conditions were within the listed ranges:

Temperature:	<u>15-35 ° C</u>
Humidity:	<u>30-60 %</u>
Atmospheric pressure:	<u>950-1050mbar</u>

3.4. Configuration of Tested System

Fig. 2-1 Configuration of Tested System

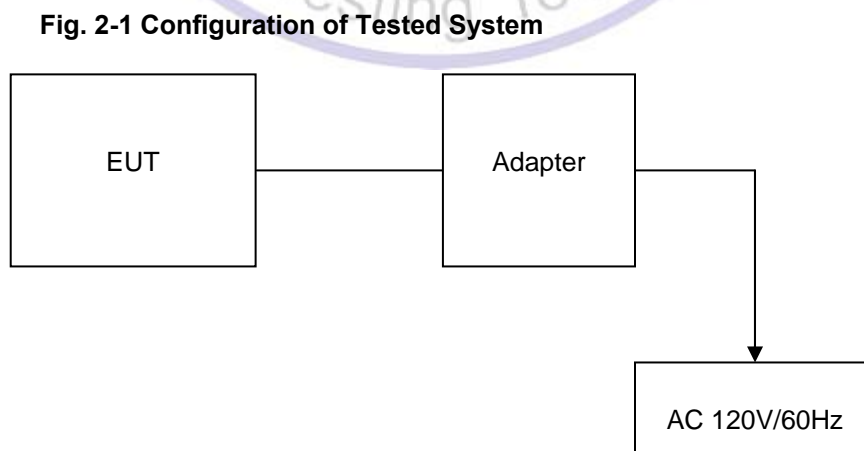

3.5. Statement of the measurement uncertainty

The data and results referenced in this document are true and accurate. The reader is cautioned that there may be errors within the calibration limits of the equipment and facilities. The measurement uncertainty was calculated for all measurements listed in this test report acc. to CISPR 16 - 4 „Specification for radio disturbance and immunity measuring apparatus and methods – Part 4: Uncertainty in EMC Measurements“ and is documented in the Shenzhen CTL Electromagnetic Technology Co., Ltd. quality system acc. to DIN EN ISO/IEC 17025. Furthermore, component and process variability of devices similar to that tested may result in additional deviation. The manufacturer has the sole responsibility of continued compliance of the device.

Hereafter the best measurement capability for CTL laboratory is reported:

Test	Range	Measurement Uncertainty	Notes
Radiated Emission	30~1000MHz	4.10dB	(1)
Radiated Emission	1~12.75GHz	4.32dB	(1)
Conducted Disturbance	0.15~30MHz	3.20dB	(1)

(1) This uncertainty represents an expanded uncertainty expressed at approximately the 95% confidence level using a coverage factor of k=2.

3.6. Equipments Used during the Test

Test Equipment	Manufacturer	Model No.	Serial No.	Calibration Date	Calibration Due Date
Bilog Antenna	Sunol Sciences Corp.	JB1	A061713	2013/07/12	2014/07/11
EMI Test Receiver	R&S	ESC13	103710	2013/07/10	2014/07/09
EMI Test Receiver	R&S	ESPI	1164.6407.07	2013/07/10	2014/07/09
Spectrum Analyzer	Agilent	E4407B	MY45108355	2013/07/06	2014/07/05
Controller	EM Electronics	Controller EM 1000	N/A	2013/07/06	2014/07/05
Horn Antenna	Sunol Sciences Corp.	DRH-118	A062013	2013/07/12	2014/07/11
Horn Antenna	SCHWARZBECK	BBHA9170	1562	2013/07/12	2014/07/11
Active Loop Antenna	SCHWARZBECK	FMZB1519	1519-037	2013/07/12	2014/07/11
LISN	R&S	ENV216	101316	2013/07/10	2014/07/09
LISN	SCHWARZBECK	NSLK8127	8127687	2013/07/10	2014/07/09
Microwave Preamplifier	HP	8349B	3155A00882	2013/07/10	2014/07/09
Amplifier	HP	8447D	3113A07663	2013/07/10	2014/07/09
Transient Limiter	Com-Power	LIT-153	532226	2013/07/10	2014/07/09

3.7. General Technical Requirements and Summary of Test Results

FCC Rules	RSS Rules	Description of Test	Test Result
§ 90.205	§ 5.4	Maximum Transmitter Power	Complies
§ 90.207	§ 5.13	Modulation Characteristic	Complies
§ 90.209	§ 5.5	Occupied Bandwidth	Complies
§ 90.210	§ 5.8	Emission Mask	Complies
§ 90.213	§ 5.3	Frequency Stability	Complies
§ 90.214	§ 5.9	Transmitter Frequency Behavior	Complies
§ 90.210	§ 5.8	Transmitter Radiated Spurious Emission	Complies
§ 90.210	§ 5.8	Spurious Emission On Antenna Port	Complies

4. TEST CONDITIONS AND RESULTS

4.1. Conducted Emissions Test

TEST CONFIGURATION

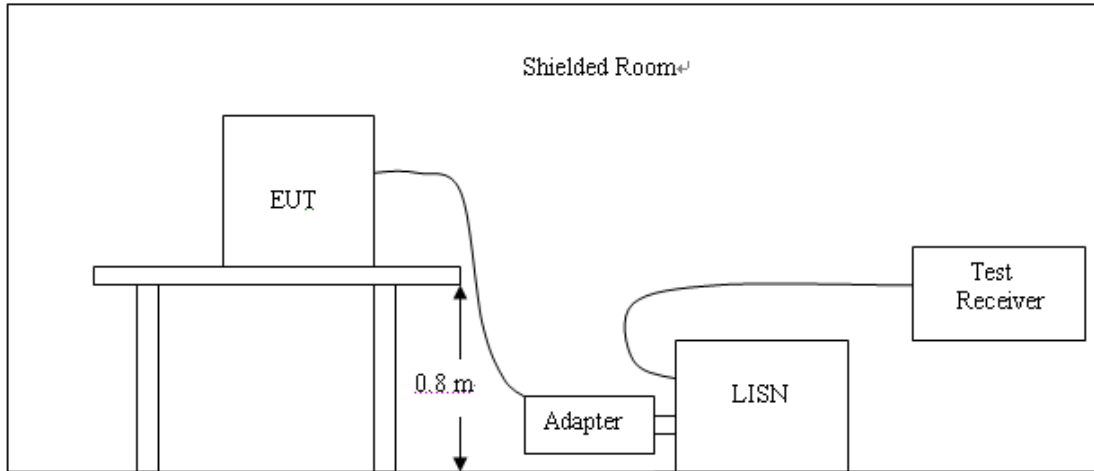

TEST PROCEDURE

- 1 The equipment was set up as per the test configuration to simulate typical actual usage per the user's manual. The EUT is a tabletop system, a wooden table with a height of 0.8 meters is used and is placed on the ground plane as per ANSI C63.4.
- 2 Support equipment, if needed, was placed as per ANSI C63.4.
- 3 All I/O cables were positioned to simulate typical actual usage as per ANSI C63.4.
- 4 The EUT received DC13.6 V power from the battery.
- 5 All support equipments received AC power from a second LISN, if any.
- 6 The EUT test program was started. Emissions were measured on each current carrying line of the EUT using a spectrum Analyzer / Receiver connected to the LISN powering the EUT. The LISN has two monitoring points: Line 1 (Hot Side) and Line 2 (Neutral Side). Two scans were taken: one with Line 1 connected to Analyzer / Receiver and Line 2 connected to a 50 ohm load; the second scan had Line 1 connected to a 50 ohm load and Line 2 connected to the Analyzer / Receiver.
- 7 Analyzer / Receiver scanned from 150 KHz to 30MHz for emissions in each of the test modes.
- 8 During the above scans, the emissions were maximized by cable manipulation.

Conducted Power Line Emission Limit

For unintentional device, according to § 15.107(a) Line Conducted Emission Limits is as following :

Frequency (MHz)	Maximum RF Line Voltage (dBµV)			
	CLASS A		CLASS B	
	Q.P.	Ave.	Q.P.	Ave.
0.15 - 0.50	79	66	66-56*	56-46*
0.50 - 5.00	73	60	56	46
5.00 - 30.0	73	60	60	50

* Decreasing linearly with the logarithm of the frequency

For intentional device, according to §15.207(a) Line Conducted Emission Limit is same as above table.

TEST RESULTS

SCAN TABLE: "Voltage (9K-30M)FIN"
 Short Description: 150K-30M Voltage

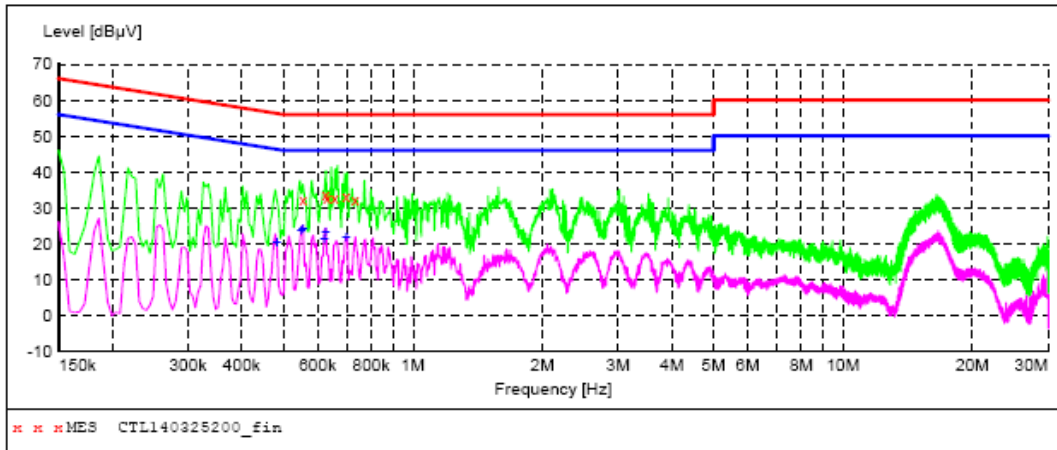

MEASUREMENT RESULT: "CTL140325200_fin"

3/25/2014 9:06AM

Frequency MHz	Level dBuV	Transd dB	Limit dBuV	Margin dB	Detector	Line	PE
0.555000	32.20	9.8	56	23.8	QP	N	GND
0.627000	33.60	9.8	56	22.4	QP	N	GND
0.631500	32.90	9.8	56	23.1	QP	N	GND
0.658500	32.90	9.8	56	23.1	QP	N	GND
0.699000	33.20	9.8	56	22.8	QP	N	GND
0.735000	32.10	9.8	56	23.9	QP	N	GND

MEASUREMENT RESULT: "CTL140325200_fin2"

3/25/2014 9:06AM

Frequency MHz	Level dBuV	Transd dB	Limit dBuV	Margin dB	Detector	Line	PE
0.483000	20.30	9.8	46	26.0	AV	N	GND
0.550500	23.80	9.8	46	22.2	AV	N	GND
0.555000	24.00	9.8	46	22.0	AV	N	GND
0.622500	21.40	9.8	46	24.6	AV	N	GND
0.627000	23.00	9.8	46	23.0	AV	N	GND
0.699000	21.60	9.8	46	24.4	AV	N	GND

SCAN TABLE: "Voltage (9K-30M)FIN"
 Short Description: 150K-30M Voltage

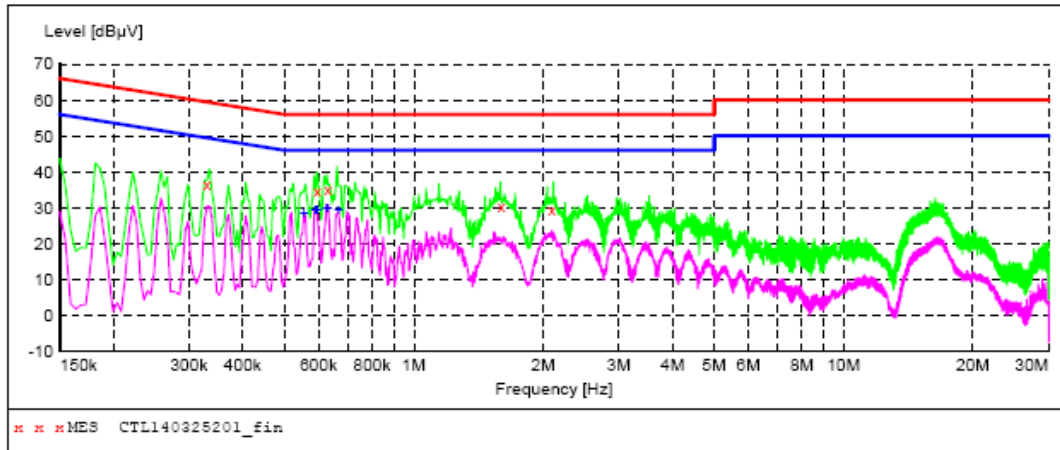

MEASUREMENT RESULT: "CTL140325201_fin"

3/25/2014 9:09AM

Frequency MHz	Level dBµV	Transd dB	Limit dBµV	Margin dB	Detector	Line	PE
0.333000	36.30	9.8	60	23.2	QP	L1	GND
0.595500	34.50	9.8	56	21.5	QP	L1	GND
0.631500	35.30	9.8	56	20.7	QP	L1	GND
1.599000	30.40	9.8	56	25.6	QP	L1	GND
2.094000	29.30	9.8	56	26.7	QP	L1	GND

MEASUREMENT RESULT: "CTL140325201_fin2"

3/25/2014 9:09AM

Frequency MHz	Level dBµV	Transd dB	Limit dBµV	Margin dB	Detector	Line	PE
0.555000	28.60	9.8	46	17.4	AV	L1	GND
0.591000	29.50	9.8	46	16.5	AV	L1	GND
0.595500	29.20	9.8	46	16.8	AV	L1	GND
0.627000	29.80	9.8	46	16.2	AV	L1	GND
0.631500	29.90	9.8	46	16.1	AV	L1	GND
0.667500	29.40	9.8	46	16.6	AV	L1	GND



4.2. Occupied Bandwidth and Emission Mask

PROVISIONS APPLICABLE

- (a). Occupied Bandwidth: The EUT was connected to the audio signal generator and the spectrum analyzer via the main RF connector, and through an appropriate attenuator. The EUT was controlled to transmit its maximum power. Then the bandwidth of 99% power can be measured by the spectrum analyzer.
- (b). Emission Mask B: For transmitters that are equipped with an audio low-pass filter pursuant to §90.211(a), the power of any emission must be below the unmodulated carrier power (P) as follows:
- (1) On any frequency removed from the assigned frequency by more than 50 percent, but not more than 100 percent of the authorized bandwidth: At least 25 dB.
 - (2) On any frequency removed from the assigned frequency by more than 100 percent, but not more than 250 percent of the authorized bandwidth: At least 35 dB.
 - (3) On any frequency removed from the assigned frequency by more than 250 percent of the authorized bandwidth: At least $43 + 10 \log (P)$ dB.
- (c). Emission Mask D, 12.5 kHz channel bandwidth equipment: For transmitters designed to operate with a 12.5 kHz channel bandwidth, any emission must be attenuated below the power (P) of the highest emission contained within the authorized bandwidth as follows:
- (1) On any frequency from the center of the authorized bandwidth f_0 to 5.625 kHz removed from f_0 : Zero dB.
 - (2) On any frequency removed from the center of the authorized bandwidth by a displacement frequency (f_d in kHz) of more than 5.625 kHz but no more than 12.5 kHz: At least $7.27(f_d - 2.88 \text{ kHz})$ dB.
 - (3) On any frequency removed from the center of the authorized bandwidth by a displacement frequency (f_d in kHz) of more than 12.5 kHz: At least $50 + 10 \log (P)$ dB or 70 dB, whichever is the lesser attenuation.

TEST CONFIGURATION

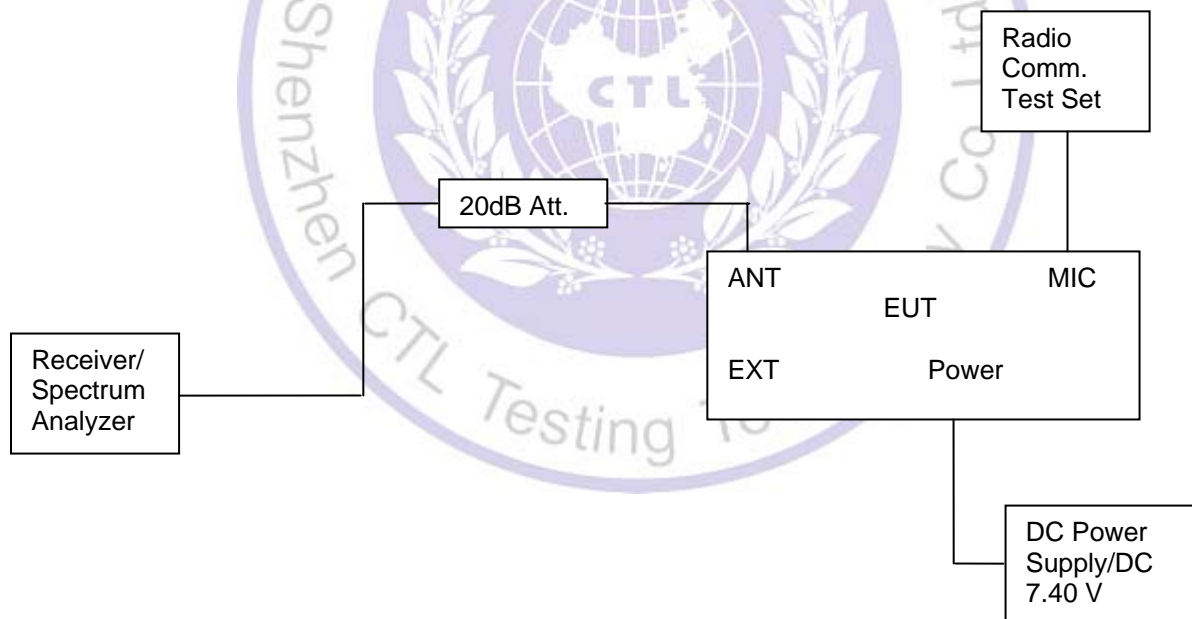

TEST PROCEDURE

- 1 The EUT was placed on a turn table which is 0.8m above ground plane.
- 2 The EUT was modulated by 2.5 KHz Sine wave audio signal; the level of the audio signal employed is 16 dB greater than that necessary to produce 50% of rated system deviation. Rated system deviation is 2.5 kHz (12.5 kHz channel spacing) and 5 kHz (25 kHz channel spacing).
- 3 Set EUT as normal operation.
- 4 Set SPA Center Frequency = fundamental frequency, RBW=300Hz, VBW= 3 KHz, span =50 KHz.
- 5 Set SPA Max hold. Mark peak, Set 99% Occupied Bandwidth and 26dB Occupied Bandwidth.
- 6 Set SPA Center Frequency=fundamental frequency, set =100Hz, VBW=1 KHz, span=50 KHz for 12.5 channel spacing and set =100Hz, VBW=1 KHz, span=50 KHz for 6.25 channel spacing

TEST RESULTS**4.2.1 Occupied Bandwidth**

Modulation Type	Channel Separation	Test Channel	Test Frequency	99% Occupied Bandwidth	26dB Occupied Band width
FM	12.5KHz	A001	450.5000	5.70 KHz	10.40 KHz
		A002	465.0000	5.70 KHz	10.40 KHz
		A003	481.5000	5.70 KHz	10.40 KHz
		A004	496.0000	5.70 KHz	10.40 KHz
		A005	511.5000	5.70 KHz	10.40 KHz
Limit		11.25KHz for 12.5KHz Channel Separation			
Test Results		Compliance			



Plots of 99% and 26dB Bandwidth Measurement

Modulation Type	Channel Separation	Freq.(MHz)	99% Bandwidth (KHz)	26dB Bandwidth (KHz)	FCC Limit (KHz)	Results
FM	12.5 KHz	450.5000	5.70	10.40	11.25	Compliance

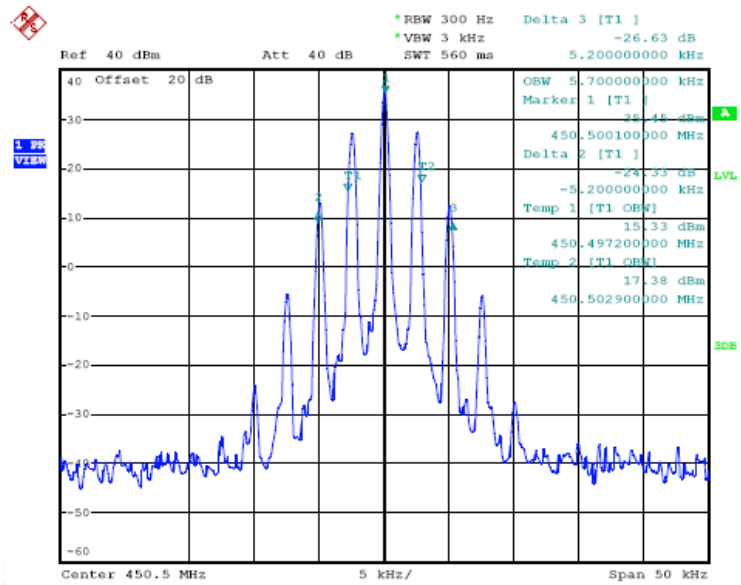

Modulation Type	Channel Separation	Freq.(MHz)	99% Bandwidth (KHz)	26dB Bandwidth (KHz)	FCC Limit (KHz)	Results
FM	12.5 KHz	465.0000	5.70	10.40	11.25	Compliance

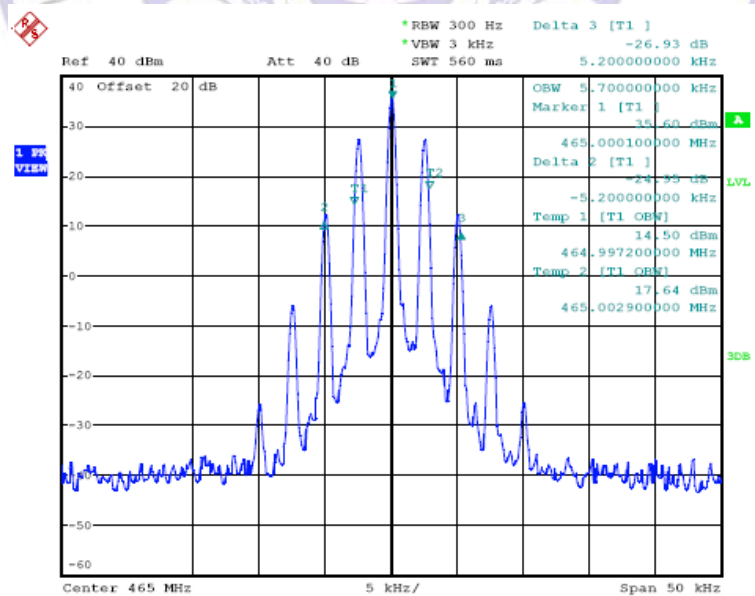

Modulation Type	Channel Separation	Freq.(MHz)	99% Bandwidth (KHz)	26dB Bandwidth (KHz)	FCC Limit (KHz)	Results
FM	12.5 KHz	481.0000	5.70	10.40	11.25	Compliance

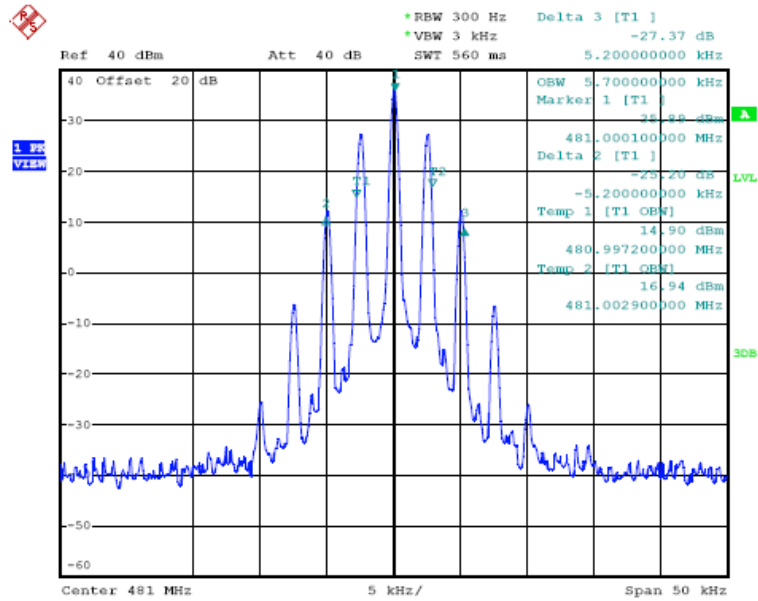

Modulation Type	Channel Separation	Freq.(MHz)	99% Bandwidth (KHz)	26dB Bandwidth (KHz)	FCC Limit (KHz)	Results
FM	12.5 KHz	496.0000	5.70	10.40	11.25	Compliance

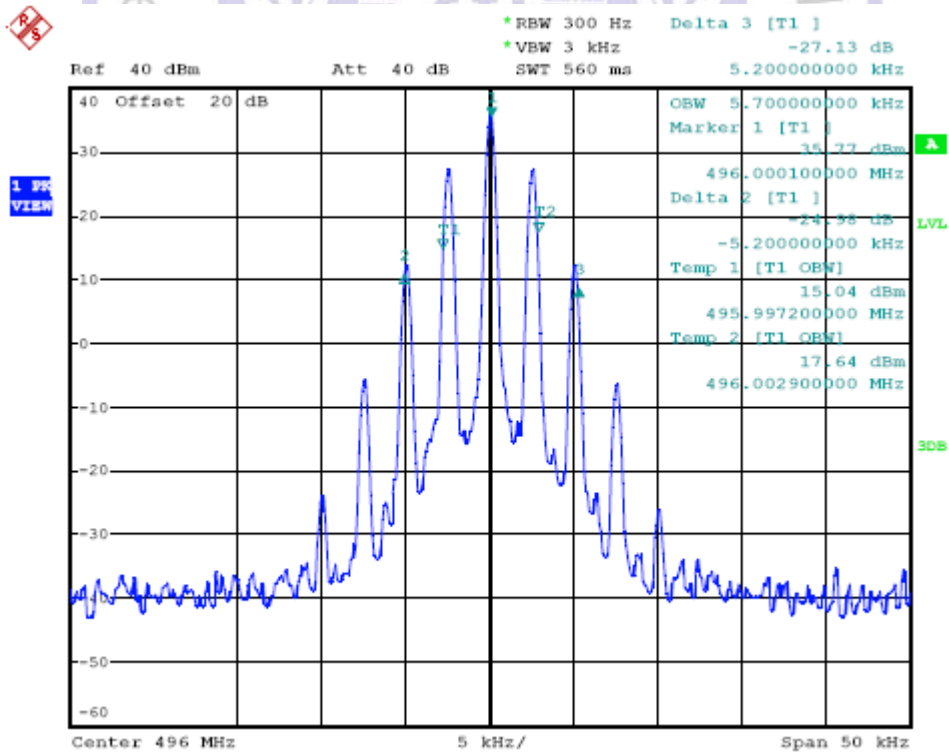

Modulation Type	Channel Separation	Freq.(MHz)	99% Bandwidth (KHz)	26dB Bandwidth (KHz)	FCC Limit (KHz)	Results
FM	12.5 KHz	511.5000	5.70	10.40	11.25	Compliance

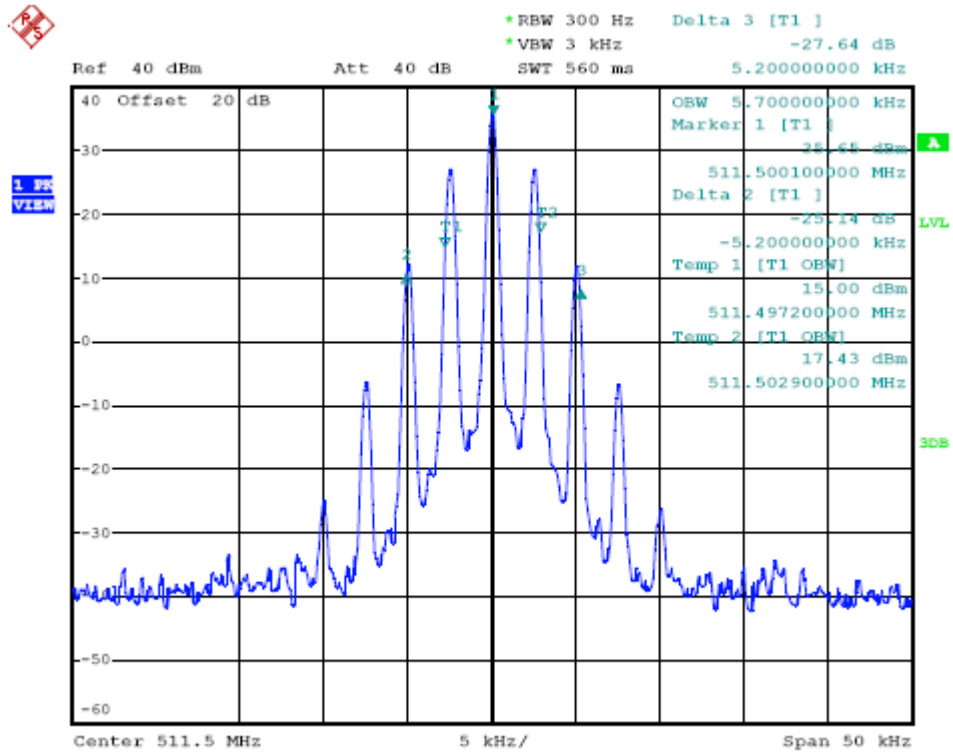

4.2.2 Emission Mask

Modulation Type	Channel Separation	Test Channel	Test Frequency	FCC Applicable Mask	RBW
FM	12.5KHz	A001	450.5000	D	100 Hz
		A002	465.0000	D	100 Hz
		A003	481.0000	D	100 Hz
		A004	496.0000	D	100 Hz
		A005	511.5000	D	100 Hz
Test Results		Compliance			

Referred as the attached plot hereinafter

Note: The black curve represents unmodulated signal.
The blue curve represents modulated signal.

Modulation Type	Channel Separation	Freq.(MHz)	FCC Applicable Mask	RBW	Audio Freq. (KHz)	Results
FM	12.5 KHz	450.5000	D	100Hz	2.5	Compliance

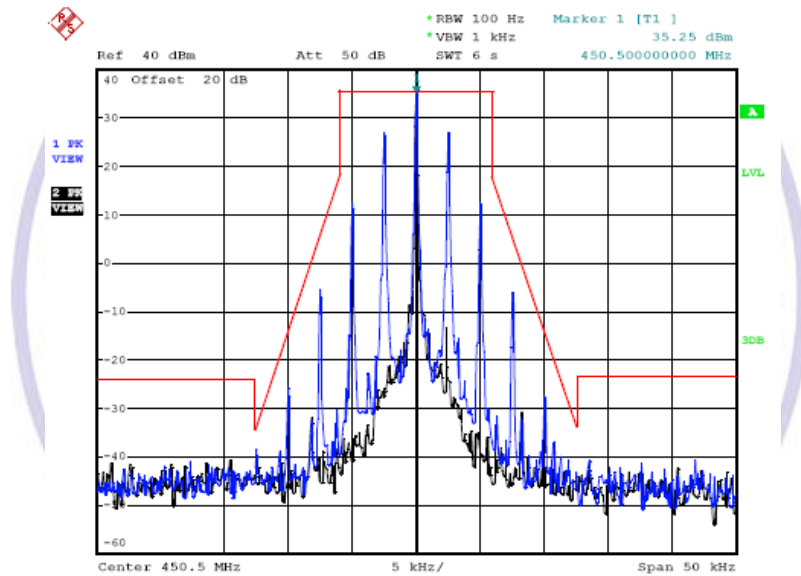

12.5 kHz Channel Spacing, 450.5000 MHz, 2500 Hz Audio Modulation Only

Modulation Type	Channel Separation	Freq.(MHz)	FCC Applicable Mask	RBW	Audio Freq. (KHz)	Results
FM	12.5 KHz	465.0000	D	100Hz	2.5	Compliance

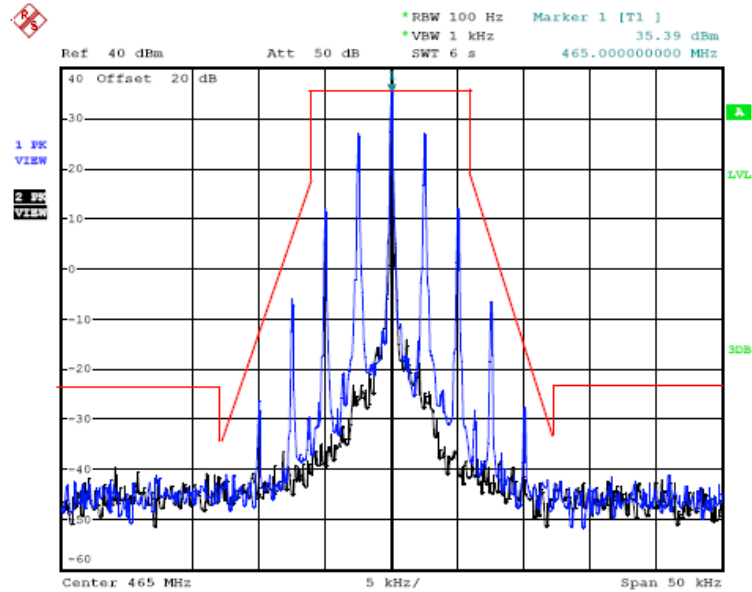

12.5 kHz Channel Spacing, 465.0000 MHz, 2500 Hz Audio Modulation Only

Modulation Type	Channel Separation	Freq.(MHz)	FCC Applicable Mask	RBW	Audio Freq. (KHz)	Results
FM	12.5 KHz	481.0000	D	100Hz	2.5	Compliance

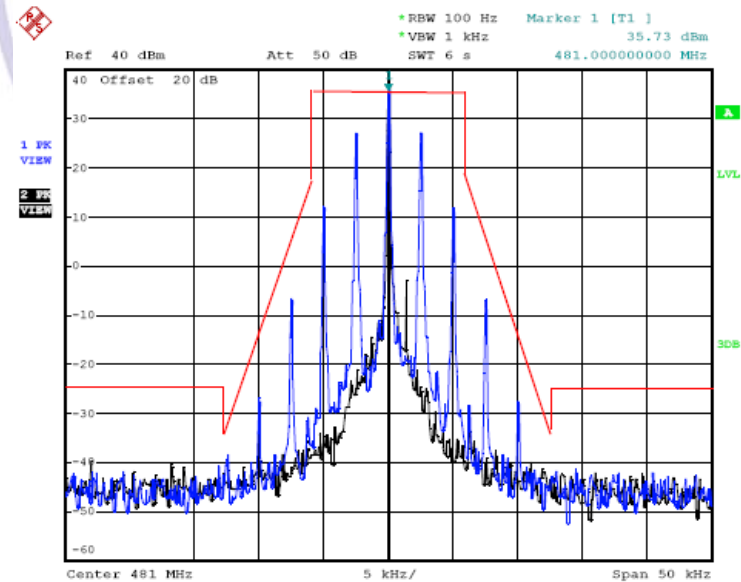

12.5 kHz Channel Spacing, 481.0000 MHz, 2500 Hz Audio Modulation Only

Modulation Type	Channel Separation	Freq.(MHz)	FCC Applicable Mask	RBW	Audio Freq. (KHz)	Results
FM	12.5 KHz	496.0000	D	100Hz	2.5	Compliance

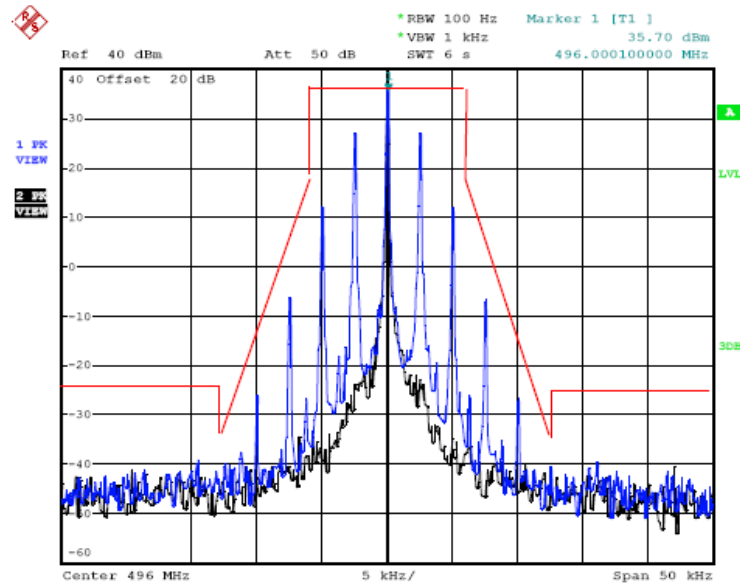

12.5 kHz Channel Spacing, 496.0000 MHz, 2500 Hz Audio Modulation Only

Modulation Type	Channel Separation	Freq.(MHz)	FCC Applicable Mask	RBW	Audio Freq. (KHz)	Results
FM	12.5 KHz	511.5000	D	100Hz	2.5	Compliance

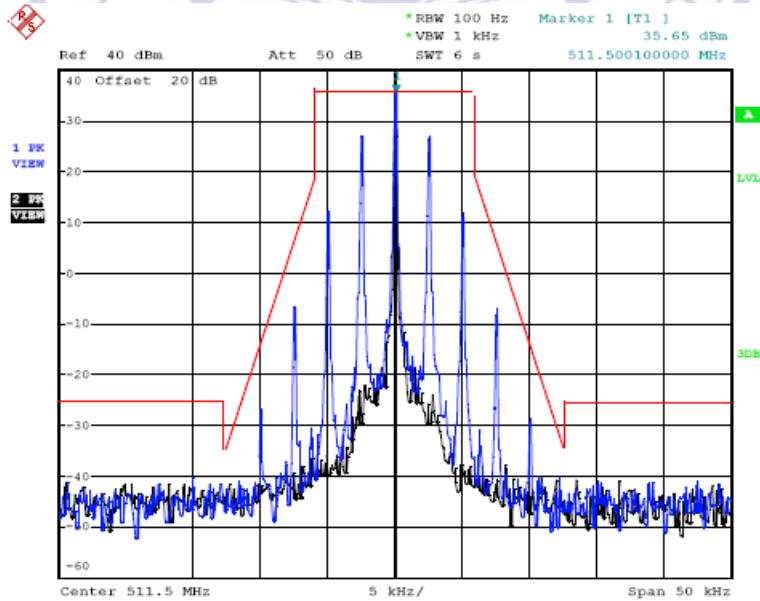

12.5 kHz Channel Spacing, 511.5000 MHz, 2500 Hz Audio Modulation Only

4.3. Radiated Spurious Emission Test

TEST APPLICABLE

According to the TIA/EIA 603 test method, and according to Section 90.210, the power of each unwanted emission shall be less than Transmitted Power as specified below for transmitters designed to operate with 12.5 KHz channel bandwidth:

- 1 On any frequency removed from the center of the authorized bandwidth f_0 to 5.625 KHz removed from f_0 : Zero dB
 - 2 On any frequency removed from the center of the authorized bandwidth by a displacement frequency (f_d in KHz) f_0 of more than 5.625 KHz but no more than 12.5 KHz: At least 7.27dB
 - 3 On any frequency removed from the center of the authorized bandwidth by a displacement frequency (f_d in KHz) f_0 of more than 12.5 KHz: At least $50+10 \log (P)$ dB or 70 dB, which ever is lesser attenuation.
- For transmitters designed to transmit with 25 KHz channel separation and equipped with an audio low-pass filter, the power of any emission must be attenuated below the unmodulated carrier power (P) as following:

- 1 On any frequency removed from the assigned frequency by more than 50 percent, but no more than 100 percent of the authorized bandwidth: At least 25 dB.
- 2 On any frequency removed from the assigned frequency by more than 100 percent, but no more than 250 percent of the authorized bandwidth: At least 35 dB.
- 3 On any frequency removed from the assigned frequency by more than 250 percent of the authorized bandwidth: At least $43+10\log (P)$ dB.

TEST CONFIGURATION

Below 1GHz

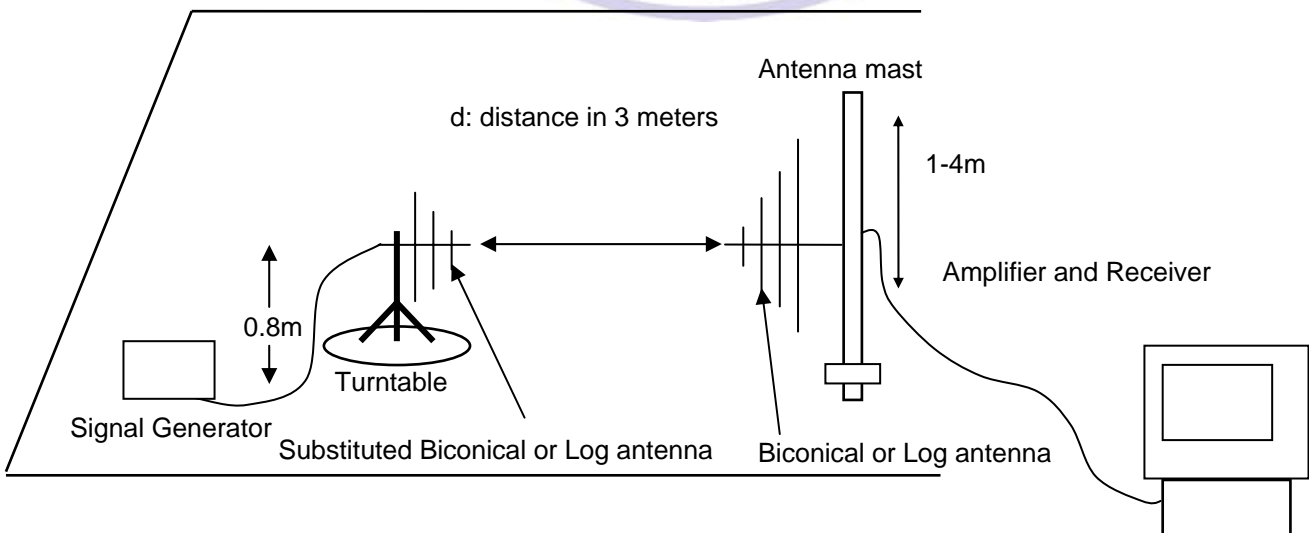
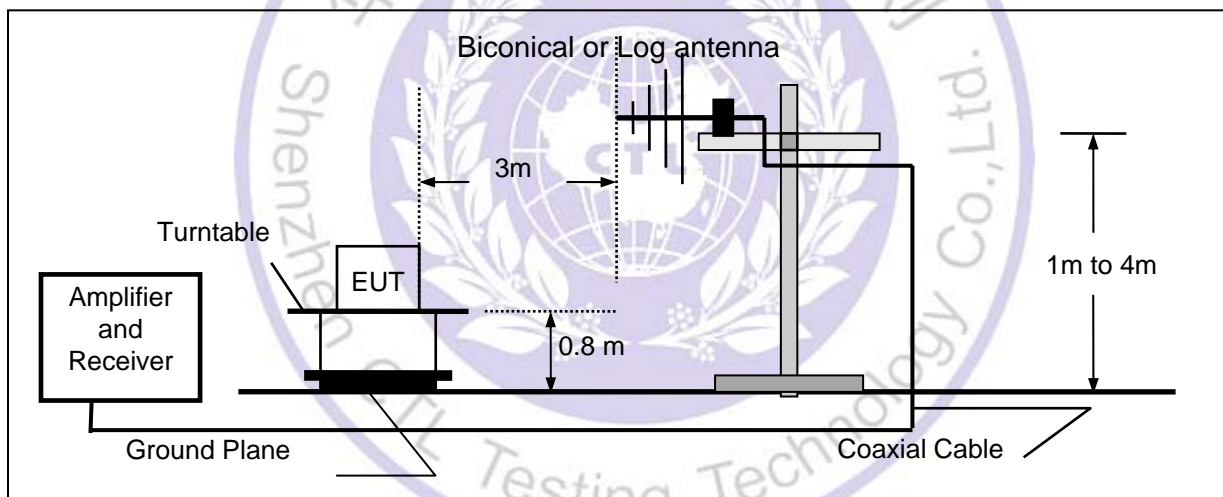

Above 1GHz

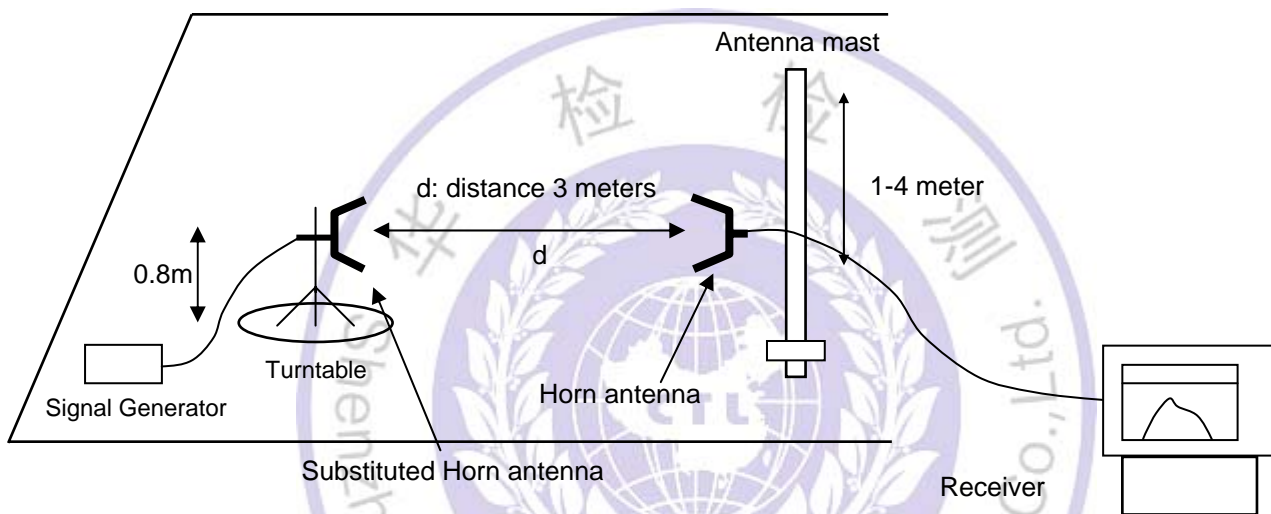
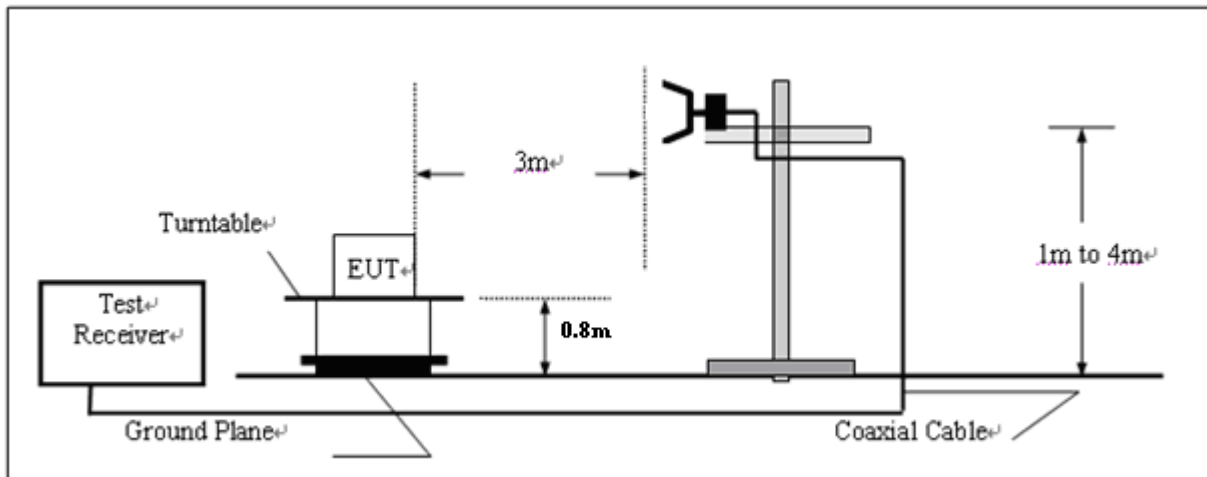
**TEST PROCEDURE**

- 1 Set the EMI Receiver (for measuring E-Field) and Receiver (for measuring EIRP) as follows:
Center Frequency: equal to the signal source
Resolution BW: 100 KHz
Video BW: VBW > RBW
Detector Mode: positive
Average: off
Span: 3 x the signal bandwidth
- 2 Load an appropriate correction factors file in EMI Receiver for correcting the field strength reading level
Total Correction Factor recorded in the EMI Receiver = Cable Loss + Antenna Factor + Amplifier Gain
 $E \text{ (dBuV/m)} = \text{Reading (dBuV)} + \text{Total Correction Factor (dB)}$
- 3 The transmitter under test was placed at the specified height on a non-conducting turntable (80 cm height)
- 4 Substitute the EUT by a signal generator and one of the following transmitting antenna (substitution antenna):
DIPOLE antenna for frequency from 30-1000 MHz or
HORN antenna for frequency above 1 GHz}.
- 5 Mount the transmitting antenna at 1.0 meter high from the ground plane.
- 6 Use one of the following antenna as a receiving antenna:
DIPOLE antenna for frequency from 30-1000 MHz or
HORN antenna for frequency above 1 GHz}.
- 7 If the DIPOLE antenna is used, tune it's elements to the frequency as specified in the calibration manual.
- 8 Adjust both transmitting and receiving antenna in a VERTICAL polarization.
- 9 Tune the EMI Receivers to the test frequency.
- 10 Lower or raise the test antenna from 1 to 4 meters until the maximum signal level was detected.
- 11 The transmitter was rotated through 360° about a vertical axis until a higher maximum signal was received.
- 12 Lower or raise the test antenna from 1 to 4 meters until the maximum signal level was detected.

- 13 Adjust input signal to the substitution antenna until an equal or a known related level to that detected from the transmitter was obtained in the test receiver.
- 14 Record the power level read from the Average Power Meter and calculate the ERP/EIRP as follows:

$$P = P_1 - L_1 = (P_2 + L_2) - L_1 = P_3 + A + L_2 - L_1$$

$$EIRP = P + G_1 = P_3 + L_2 - L_1 + A + G_1$$

$$ERP = EIRP - 2.15 \text{ dB}$$
 Total Correction factor in EMI Receiver = $L_2 - L_1 + G_1$
 Where:
 P: Actual RF Power fed into the substitution antenna port after corrected.
 P₁: Power output from the signal generator
 P₂: Power measured at attenuator A input
 P₃: Power reading on the Average Power Meter
 EIRP: EIRP after correction
 ERP: ERP after correction
- 15 Adjust both transmitting and receiving antenna in a Horizontal polarization, then repeat step (11) to (14).
- 16 Repeat step (4) to (16) for different test frequency
- 17 Repeat steps (3) to (12) with the substitution antenna oriented in horizontal polarization.
- 18 Actual gain of the EUT's antenna is the difference of the measured EIRP and measured RF power at the RF port. Correct the antenna gain if necessary.

TEST RESULTS

Modulation Type: FM

FCC Part 22.359, 74.462, 80.211 and 90.210 and RSS Gen, RSS 119 Issue 11 (12.5 kHz Bandwidth only):
 On any frequency removed from the center of the authorized bandwidth by a displacement frequency (f_d in kHz) of more than 12.5 kHz at least:

Low: $50 + 10 \log(P_{\text{watts}}) = 50 + 10 \log(4.30) = 56.33 \text{ dB}$

High: $50 + 10 \log(P_{\text{watts}}) = 50 + 10 \log(4.71) = 56.73 \text{ dB}$

Note: In general, the worse case attenuation requirement shown above was applied.

Calculation: Limit (dBm) = EL-50-10log₁₀ (TP)

Notes: EL is the emission level of the Output Power expressed in dBm,
 In this application, the EL is 36.99 dBm.
 Limit (dBm) = 36.99-50-10log₁₀ (4.71) = -20 dBm

Note: 1. In general, the worse case attenuation requirement shown above was applied.

2. The measurement frequency range from 30 MHz to 5 GHz.

3. *** means that the emission level is too low to be measured or at least 20 dB down than the limit.

Modulation		FM		Channel Separation		12.5KHz		
Test Channel		A001		Test Frequency		450.5000 MHz		
Frequency (MHz)	E-Field Level (dBuv/m)	EMI Detector (Peak/QP)	Antenna Polarization	Antenna Height (cm)	Table Angle (Degree)	ERP measured by Substitution Method (dBm)	Limit (dBm)	Margin (dB)
901.000	57.39	Peak	H	367	231	-35.02	-20	15.02
1351.500	61.99	Peak	H	100	178	-34.51	-20	14.51
1802.000	68.62	Peak	H	245	304	-28.37	-20	8.37
...			H					
901.000	55.54	Peak	V	100	341	-40.08	-20	20.08
1351.500	62.77	Peak	V	100	107	-32.64	-20	12.64
1802.000	69.14	Peak	V	155	88	-29.50	-20	9.50
...	...		V					

Modulation		FM		Channel Separation		12.5KHz		
Test Channel		A002		Test Frequency		465.0000 MHz		
Frequency (MHz)	E-Field Level (dBuV/m)	EMI Detector (Peak/QP)	Antenna Polarization	Antenna Height (cm)	Table Angle (Degree)	ERP measured by Substitution Method (dBm)	Limit (dBm)	Margin (dB)
930.000	60.24	Peak	H	144	300	-35.07	-20	15.07
1395.000	56.37	Peak	H	200	34	-40.90	-20	20.90
1860.000	58.29	Peak	H	290	221	-37.79	-20	17.79
...			H					
930.000	58.41	Peak	V	100	93	-37.56	-20	17.56
1395.000	59.30	Peak	V	108	354	-36.82	-20	16.82
1860.000	61.71	Peak	V	114	122	-34.09	-20	14.09
...	...		V					

Modulation		FM		Channel Separation		12.5KHz		
Test Channel		A003		Test Frequency		481.0000 MHz		
Frequency (MHz)	E-Field Level (dBuV/m)	EMI Detector (Peak/QP)	Antenna Polarization	Antenna Height (cm)	Table Angle (Degree)	ERP measured by Substitution Method (dBm)	Limit (dBm)	Margin (dB)
962.000	56.41	Peak	H	400	189	-39.17	-20	19.17
1443.000	65.57	Peak	H	124	204	-30.67	-20	10.67
1924.000	69.52	Peak	H	150	77	-27.40	-20	7.40
...			H					
962.000	53.36	Peak	V	118	331	-43.28	-20	23.28
1443.000	68.17	Peak	V	100	144	-28.15	-20	8.15
1924.000	70.58	Peak	V	100	123	-26.59	-20	6.59
...	...		V					

Modulation		FM		Channel Separation		12.50KHz		
Test Channel		A004		Test Frequency		496.0000 MHz		
Frequency (MHz)	E-Field Level (dBuV/m)	EMI Detector (Peak/QP)	Antenna Polarization	Antenna Height (cm)	Table Angle (Degree)	ERP measured by Substitution Method (dBm)	Limit (dBm)	Margin (dB)
992.000	60.51	Peak	H	300	288	-35.51	-25	10.51
1488.000	62.57	Peak	H	289	301	-34.65	-25	9.65
1984.000	68.05	Peak	H	204	178	-28.32	-25	3.32
...	...		H					
992.000	55.43	Peak	V	105	348	-40.94	-25	15.94
1488.000	64.12	Peak	V	150	9	-32.96	-25	7.96
1984.000	67.75	Peak	V	100	122	-28.03	-25	3.03
...	...		V					

Modulation		FM		Channel Separation		12.50KHz		
Test Channel		A005		Test Frequency		511.5000 MHz		
Frequency (MHz)	E-Field Level (dBuV/m)	EMI Detector (Peak/QP)	Antenna Polarization	Antenna Height (cm)	Table Angle (Degree)	ERP measured by Substitution Method (dBm)	Limit (dBm)	Margin (dB)
1023.000	60.88	Peak	H	205	305	-35.93	-25	10.93
1534.5000	59.28	Peak	H	122	156	-37.58	-25	12.58
2046.000	60.00	Peak	H	150	99	-36.84	-25	11.84
...	...		H					
1023.000	58.55	Peak	V	100	0	-38.07	-25	13.07
1534.5000	62.16	Peak	V	100	299	-34.24	-25	9.24
2046.000	59.44	Peak	V	150	145	-37.19	-25	12.19
...	...		V					



4.4. Spurious Emission On Antenna Port

TEST APPLICABLE

The same as Section 4.3

TEST PROCEDURE

The RF output of the EUT was connected to a spectrum analyzer through appropriate attenuation. The resolution bandwidth of the spectrum analyzer was set to 100 kHz. Sufficient scans were taken to show any out of band emission up to 10th. Harmonic for the lower and the highest frequency range. Set RBW 100 kHz, VBW 300 kHz in the frequency band 30MHz to 1GHz, while set RBW=1MHz, VBW=3MHz from the 1GHz to 10th Harmonic.

The audio input was set to 0 to get the unmodulated carrier, the resulting picture is print out for each channel separation.

TEST CONFIGURATION

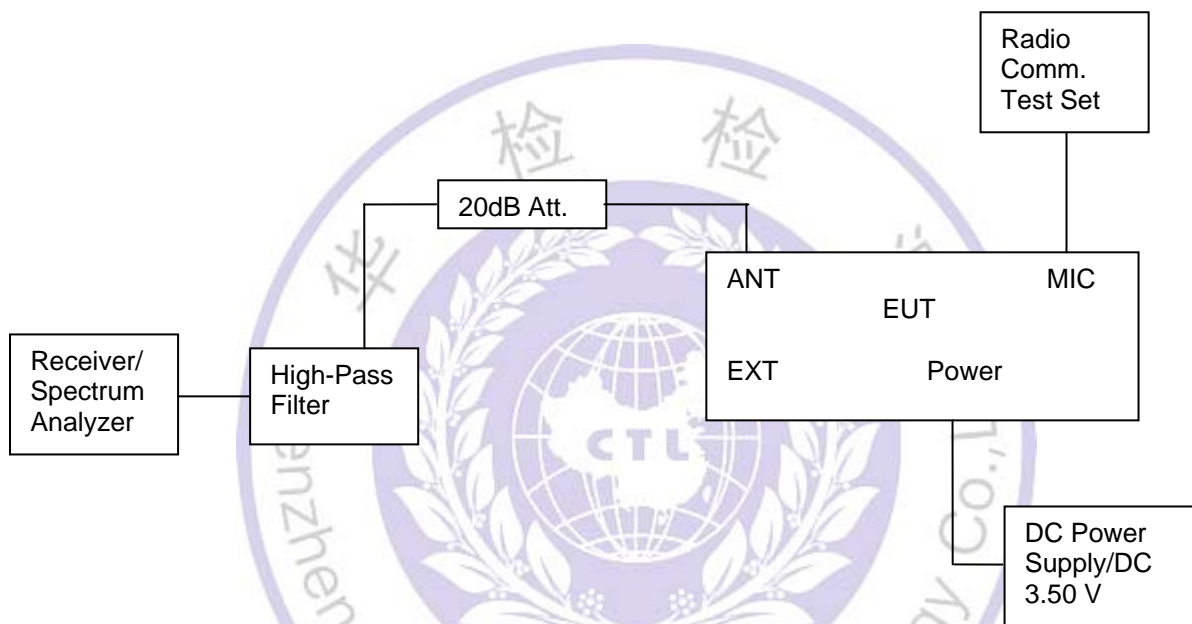

TEST RESULTS:

Modulation Type: FM

FCC Part 22.359, 74.462, 80.211 and 90.210 and RSS Gen, RSS 119 Issue 11 (12.5 kHz Bandwidth only):
On any frequency removed from the center of the authorized bandwidth by a displacement frequency (f_d in kHz) of more than 12.5 kHz at least:

Low: $50 + 10 \log(P_{\text{watts}}) = 50 + 10 \log(4.30) = 56.33 \text{ dB}$

High: $50 + 10 \log(P_{\text{watts}}) = 50 + 10 \log(4.71) = 56.73 \text{ dB}$

Note: In general, the worse case attenuation requirement shown above was applied.

Calculation: Limit (dBm) = EL - 50 - 10log₁₀(TP)

Notes: EL is the emission level of the Output Power expressed in dBm,

In this application, the EL is 36.99 dBm.

Limit (dBm) = 36.99 - 50 - 10log₁₀(4.71) = -20 dBm

Note: 1. In general, the worse case attenuation requirement shown above was applied.

2. The measurement frequency range from 30 MHz to 6 GHz.

Modulation Type	Channel Separation	Test Channel	Test Frequency (MHz)	Maximum Conducted Spurious Emissions Below 1GHz		Maximum Conducted Spurious Emissions Above 1GHz	
				Frequency (MHz)	Datum (dBm)	Frequency (MHz)	Datum (dBm)
Analog/FM	12.5KHz	A001	450.5000	813.00	-26.08	1220.00	-36.97
		A002	465.0000	836.00	-26.92	1670.00	-37.30
		A003	481.0000	871.00	-37.73	1300.00	-43.59
		A004	496.0000	907.00	-38.26	1810.00	-40.31
		A005	511.5000	939.00	-44.32	1400.00	-46.41
Limit		-20dBm for 12.5KHz Channel Separation					
Test Results		Compliance					

Plots of Spurious Emission on Antenna Port Measurement

Modulation Type	Channel Separation	Test Channel	Test Frequency (MHz)	Maximum Conducted Spurious Emissions Below 1GHz		Maximum Conducted Spurious Emissions Above 1GHz		FCC Limit
				Frequency (MHz)	Datum (dBm)	Frequency (MHz)	Datum (dBm)	
FM	12.5KHz	A001	450.5000	901.00	-34.30	1800.00	-45.31	-20dBm
Test Results				Compliance				

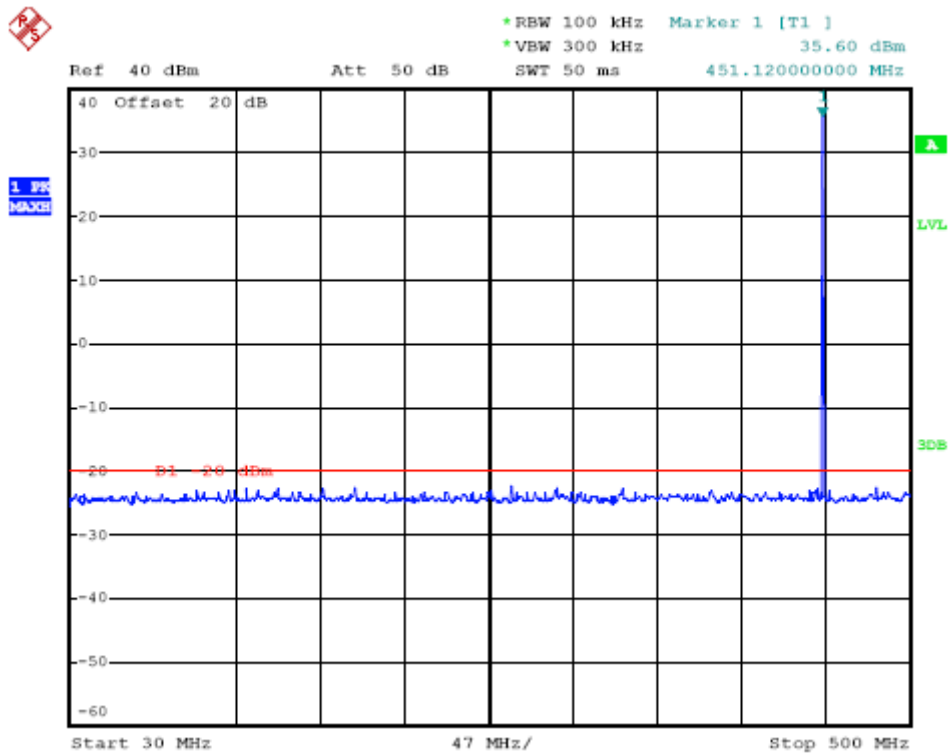

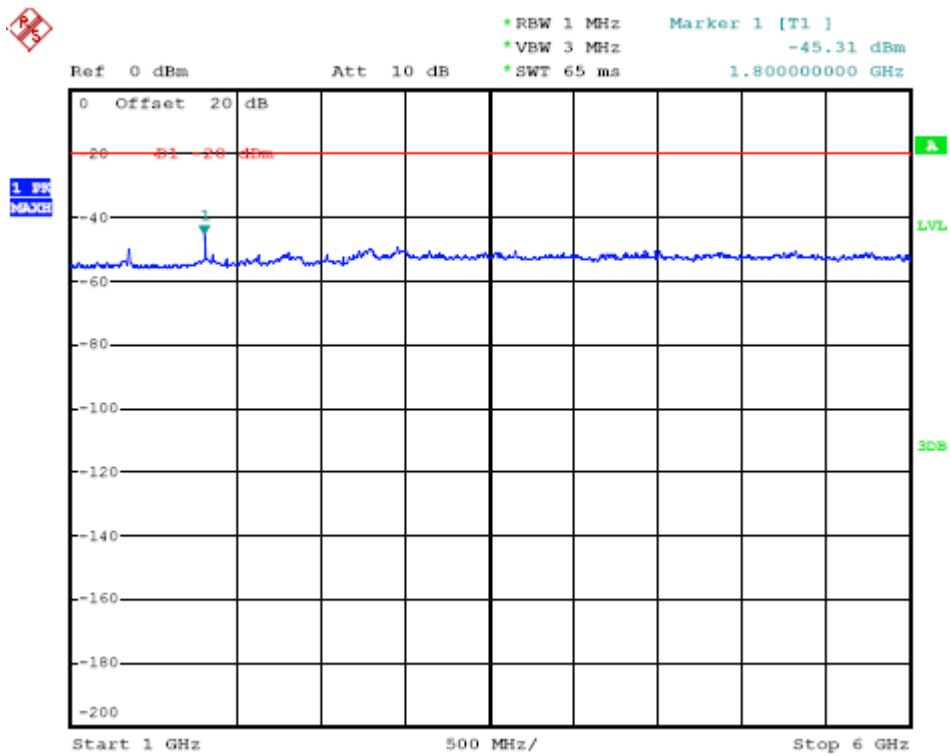
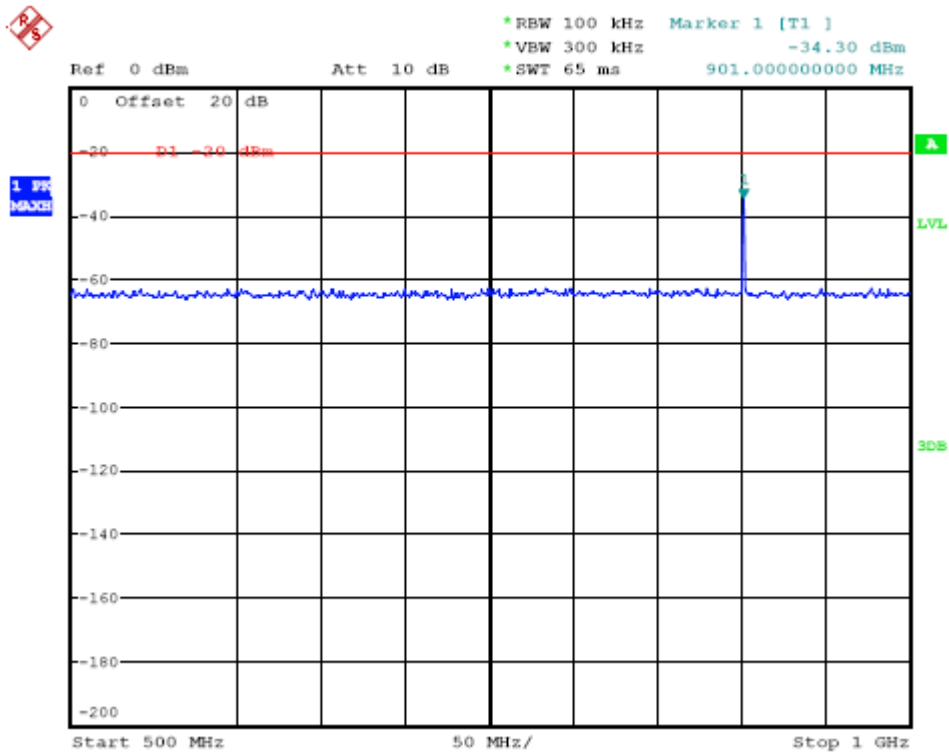

Modulation Type	Channel Separation	Test Channel	Test Frequency (MHz)	Maximum Conducted Spurious Emissions Below 1GHz		Maximum Conducted Spurious Emissions Above 1GHz		FCC Limit
				Frequency (MHz)	Datum (dBm)	Frequency (MHz)	Datum (dBm)	
FM	12.5KHz	A002	465.0000	963.00	-40.68	1860.00	-48.83	-20dBm
Test Results				Compliance				

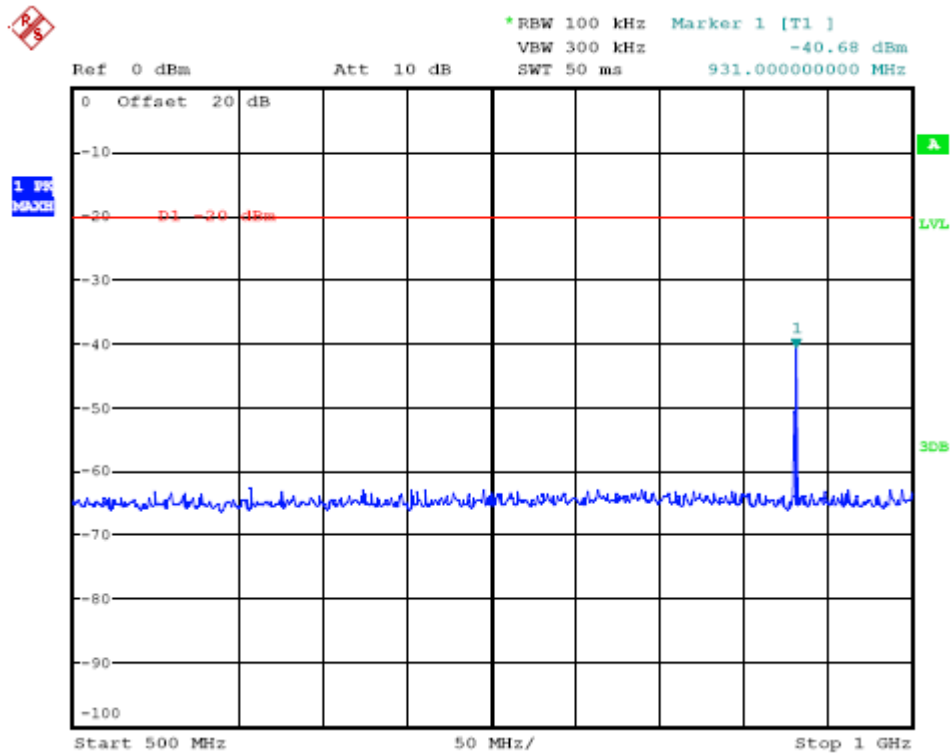
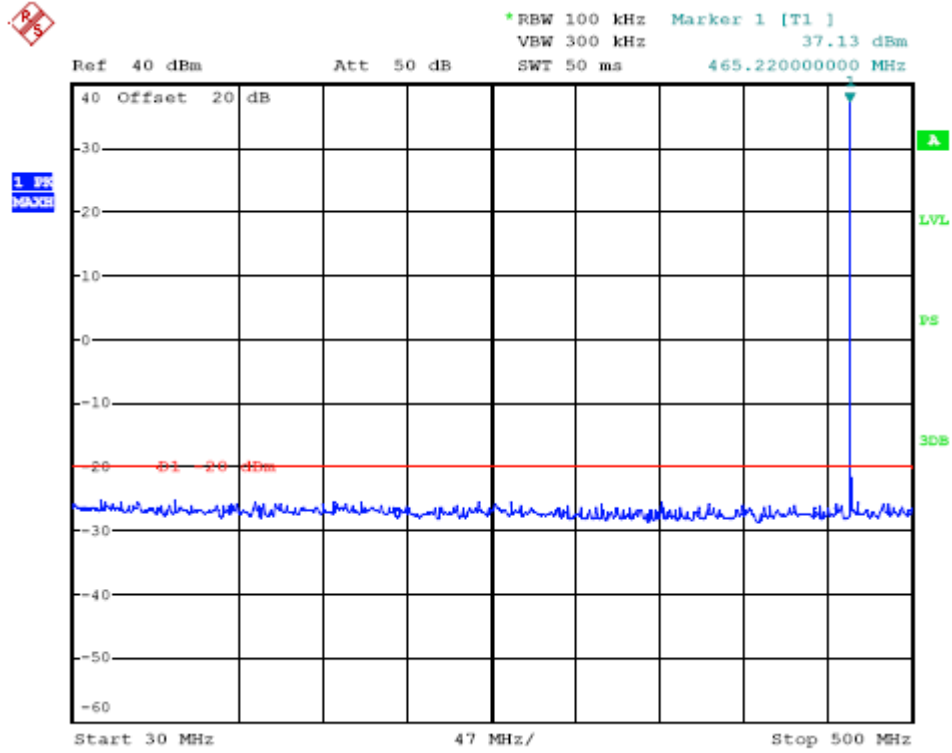

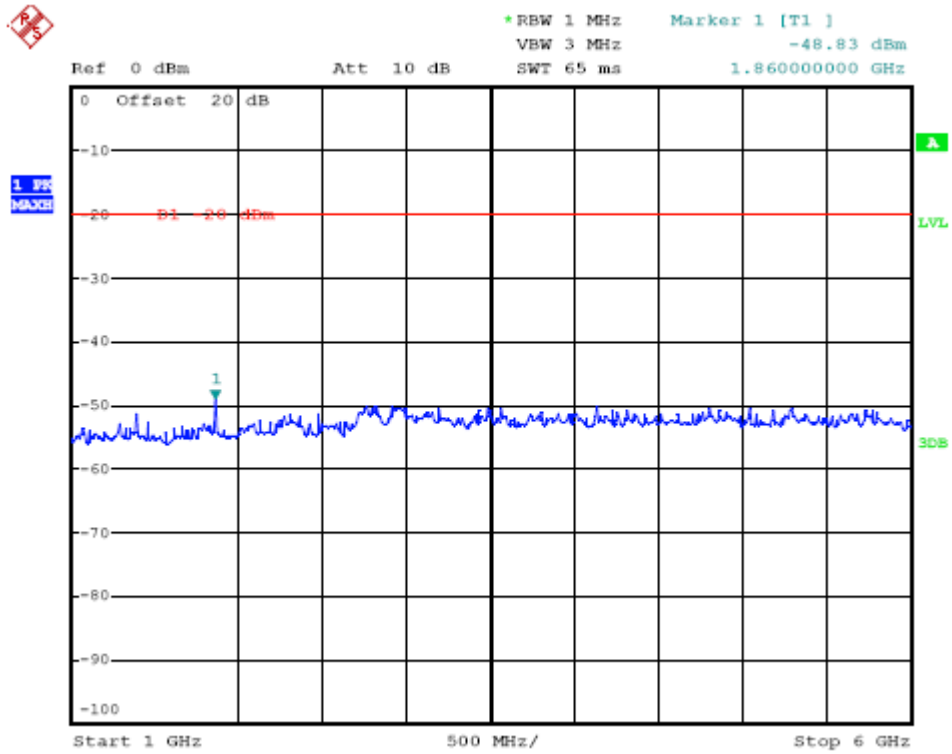

Modulation Type	Channel Separation	Test Channel	Test Frequency (MHz)	Maximum Conducted Spurious Emissions Below 1GHz		Maximum Conducted Spurious Emissions Above 1GHz		FCC Limit
				Frequency (MHz)	Datum (dBm)	Frequency (MHz)	Datum (dBm)	
FM	12.5KHz	A003	481.0000	963.00	-46.21	-----	-----	-20dBm
Test Results				Compliance				

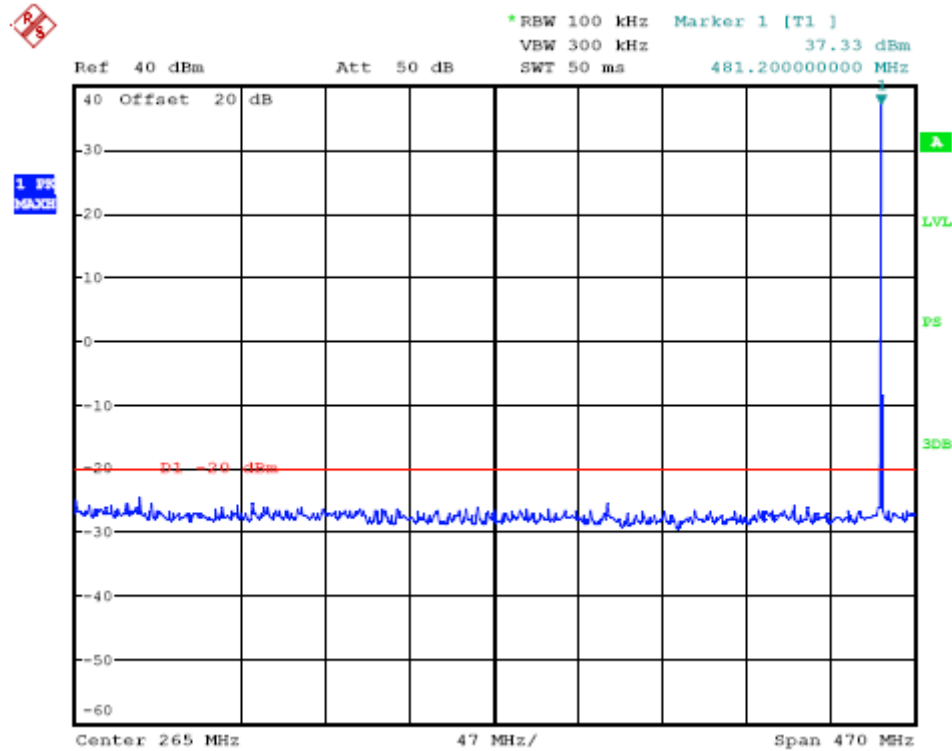

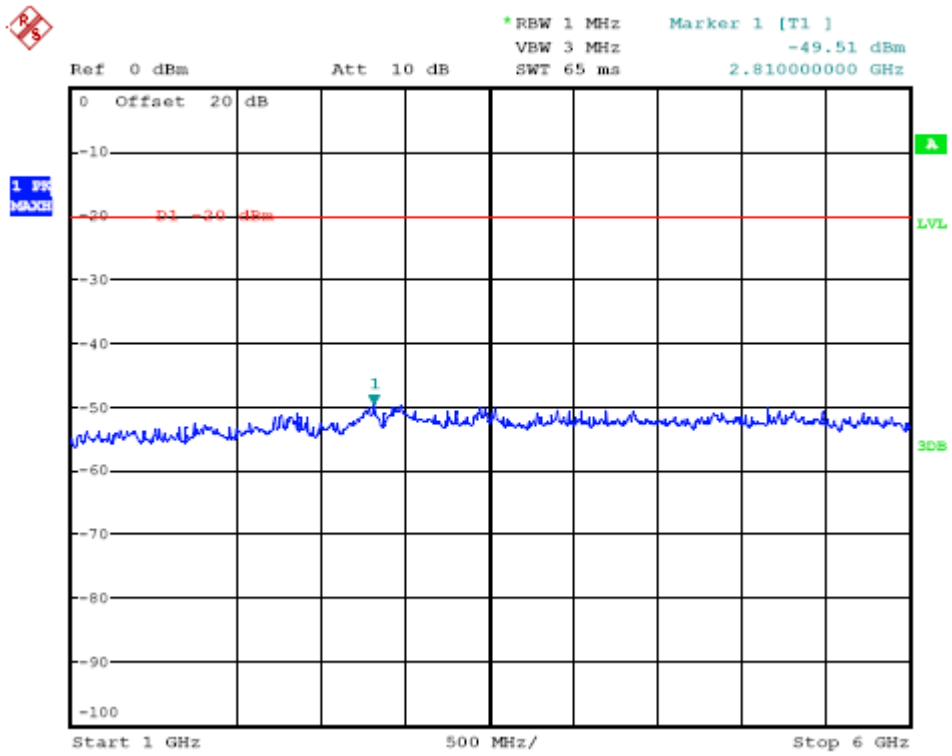
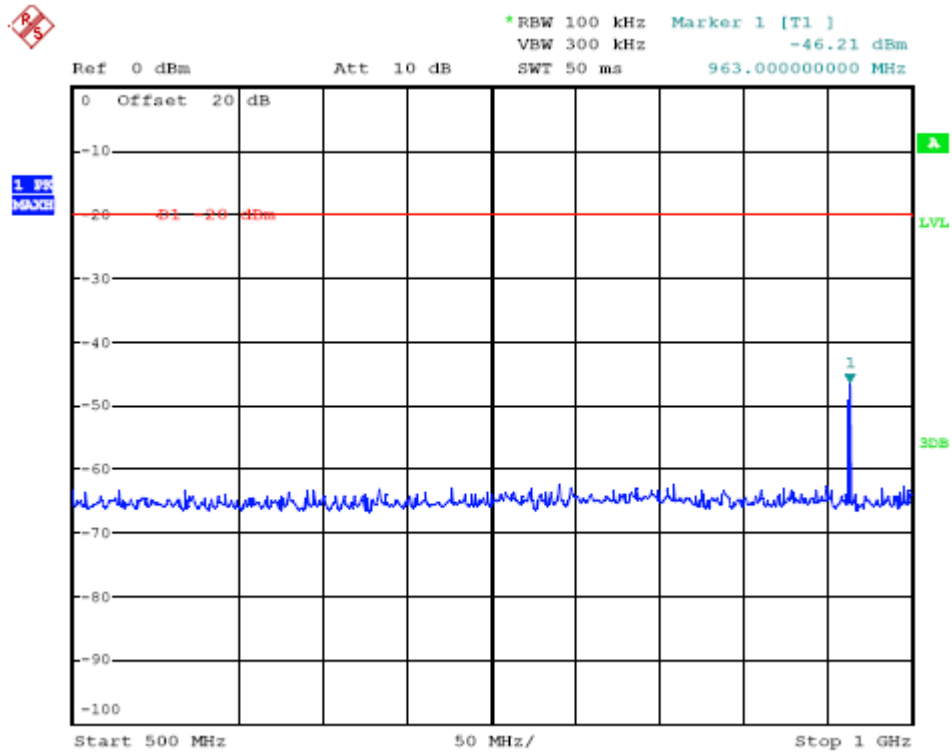

Modulation Type	Channel Separation	Test Channel	Test Frequency (MHz)	Maximum Conducted Spurious Emissions Below 1GHz		Maximum Conducted Spurious Emissions Above 1GHz		FCC Limit
				Frequency (MHz)	Datum (dBm)	Frequency (MHz)	Datum (dBm)	
FM	12.5KHz	A004	496.0000	993.00	-51.97	-----	-----	-20dBm
Test Results				Compliance				

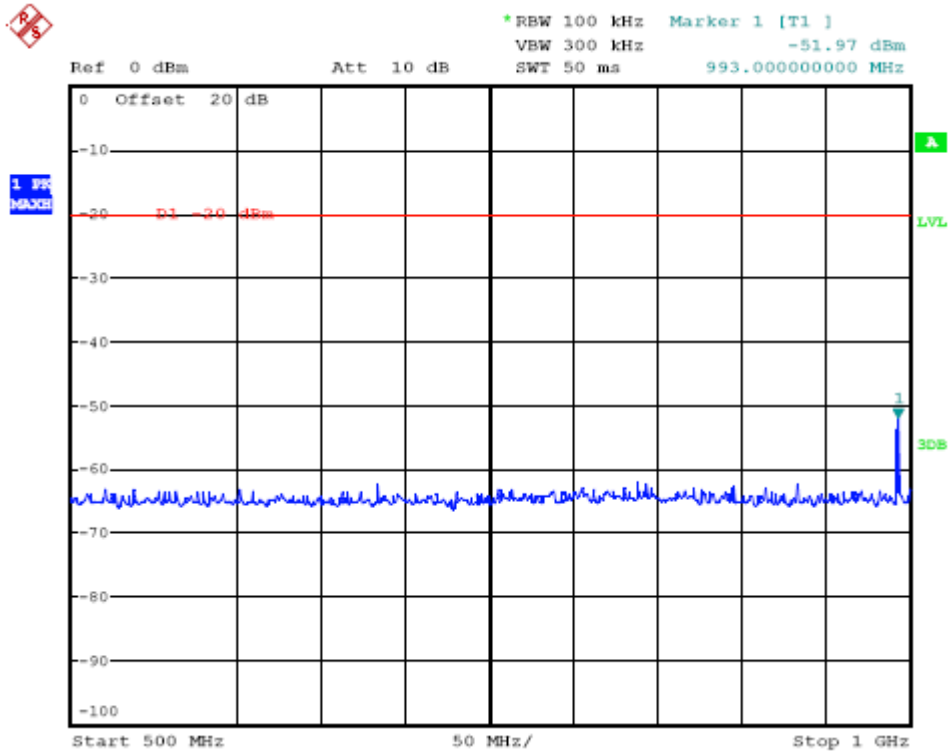
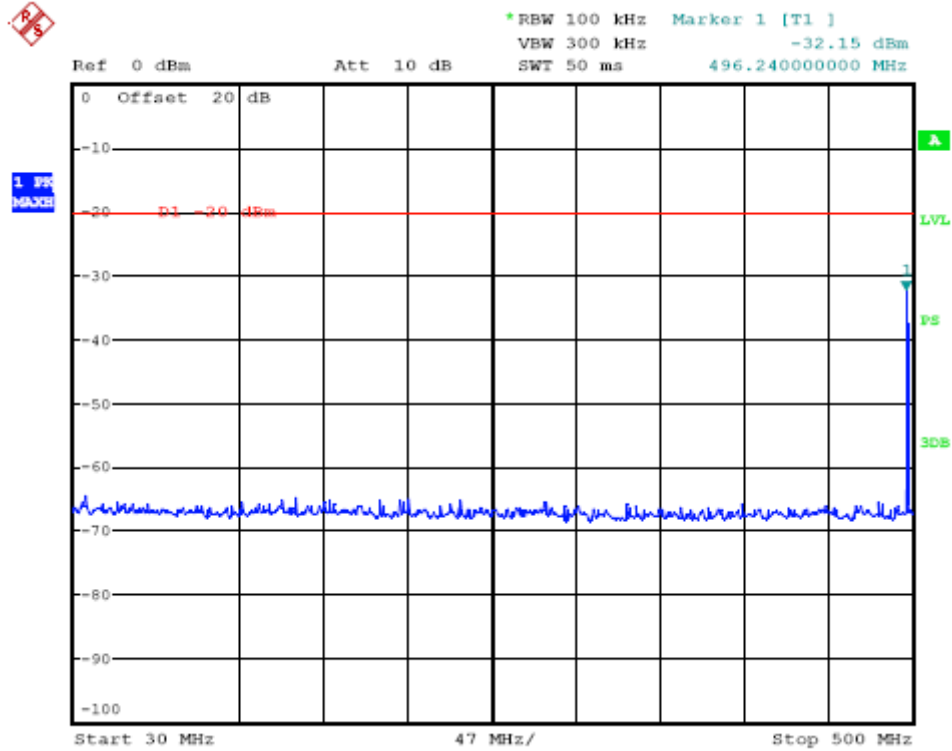

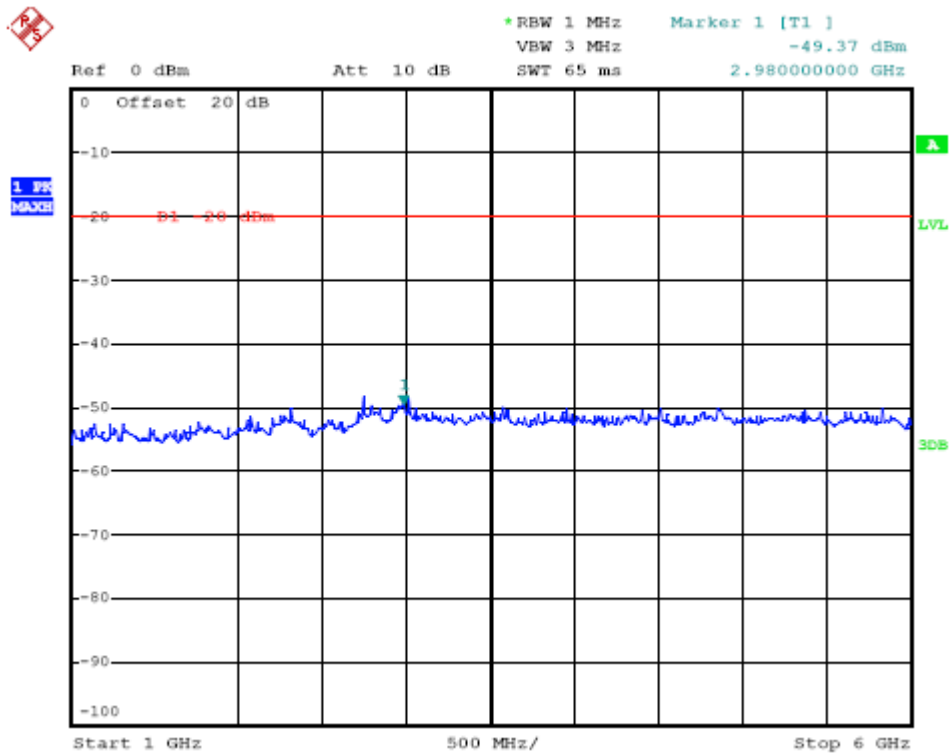

Modulation Type	Channel Separation	Test Channel	Test Frequency (MHz)	Maximum Conducted Spurious Emissions Below 1GHz		Maximum Conducted Spurious Emissions Above 1GHz		FCC Limit
				Frequency (MHz)	Datum (dBm)	Frequency (MHz)	Datum (dBm)	
FM	12.5KHz	A005	511.5000	-----	-----	3070.00	-43.90	-20dBm
Test Results				Compliance				

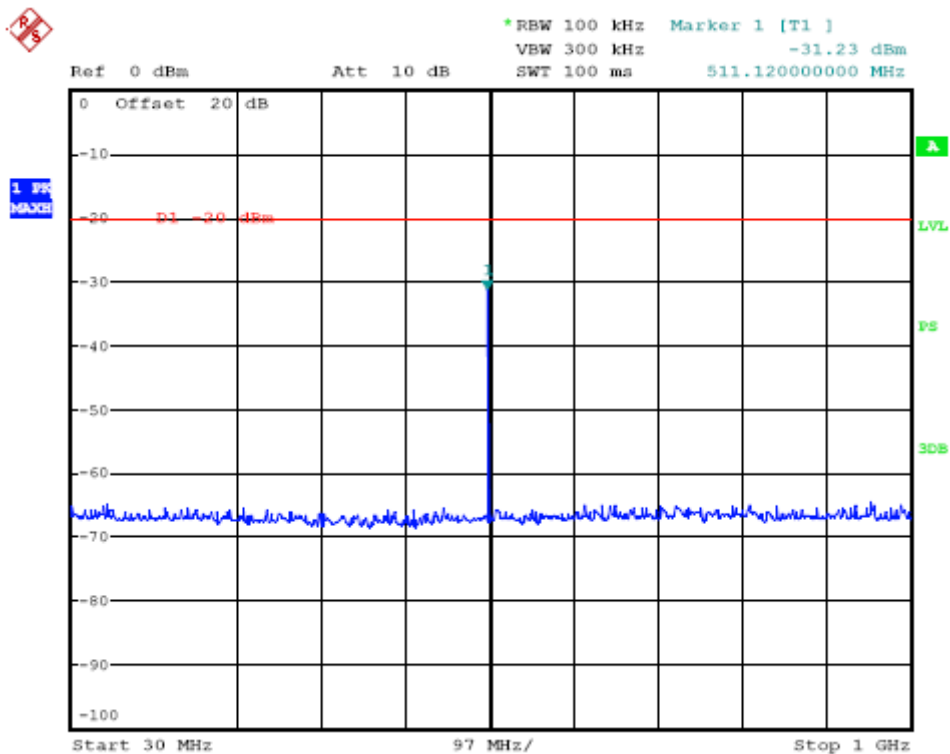

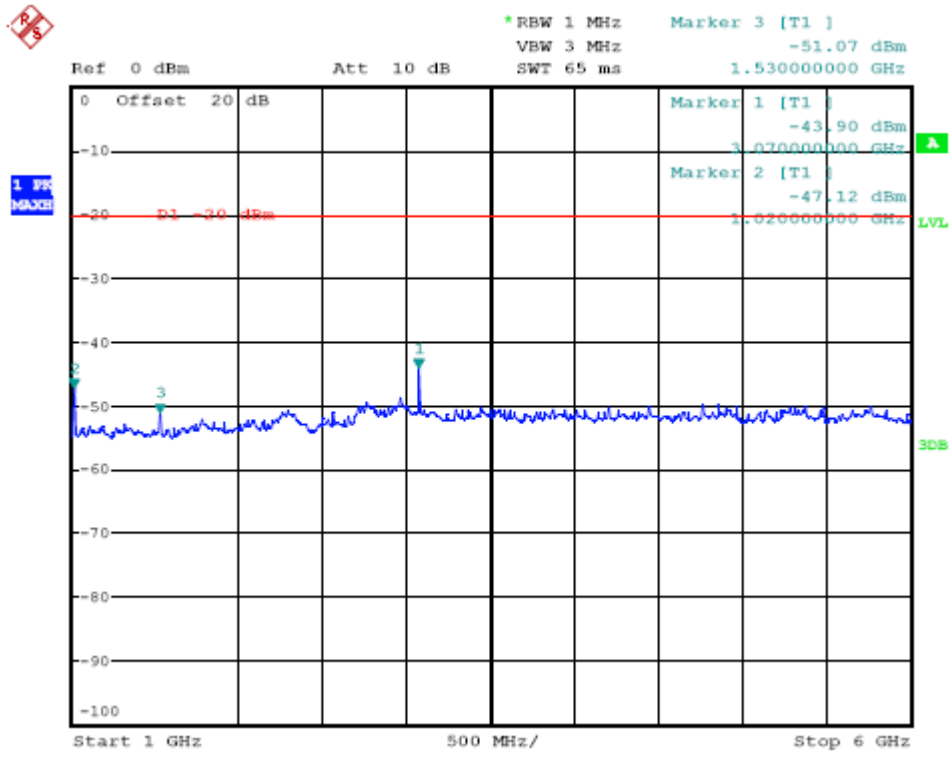

4.5. Modulation Characteristics

TEST APPLICABLE

According to CFR47 section 2.1047(a), for Voice Modulation Communication Equipment, the frequency response of the audio modulation circuit over a range of 100 to 5000Hz shall be measured.

TEST PROCEDURE

Modulation Limit

- 1 Configure the EUT as shown in figure 1, adjust the audio input for 60% of rated system deviation at 1 KHz using this level as a reference (0dB) and vary the input level from -20 to +20dB. Record the frequency deviation obtained as a function of the input level.
- 2 Repeat step 1 with input frequency changing to 300, 1004, 1500 and 2500Hz in sequence.

Audio Frequency Response

- 1 Configure the EUT as shown in figure 1.
- 2 Adjust the audio input for 20% of rated system deviation at 1 KHz using this level as a reference (0dB).
- 3 Vary the Audio frequency from 100 Hz to 3 KHz and record the frequency deviation.
- 4 Audio Frequency Response = $20\log_{10} (\text{Deviation of test frequency}/\text{Deviation of 1 KHz reference})$.

TEST CONFIGURATION

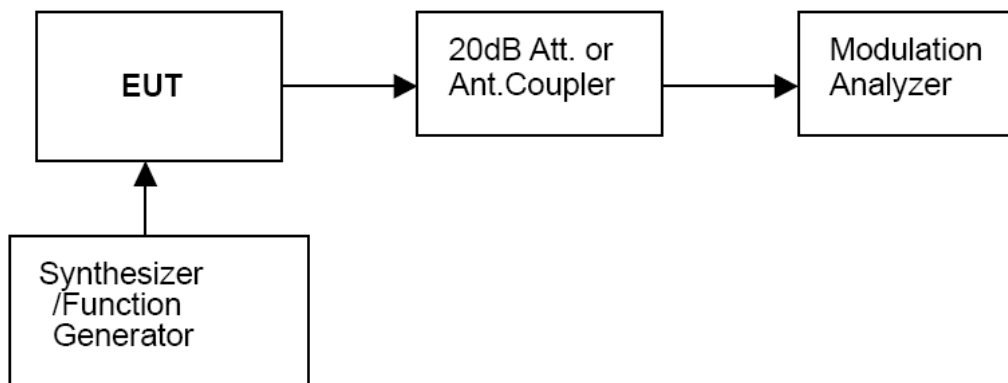

TEST RESULTS

Modulation Type: FM

12.5 KHz Channel Separation

Modulation Level(dB)	Peak Freq. Deviation At 300 Hz(KHz)	Peak Freq. Deviation At 1004 H(KHz)	Peak Freq. Deviation At 1500 Hz(KHz)	Peak Freq. Deviation At 2500 Hz(KHz)
-20	0.11	0.17	0.26	0.42
-15	0.12	0.38	0.46	0.68
-10	0.19	0.58	0.75	1.18
-5	0.28	0.89	1.26	2.05
0	0.43	1.55	2.16	2.21
+5	0.71	2.24	2.25	2.20
+10	1.22	2.26	2.23	2.21
+15	2.11	2.25	2.23	2.21
+20	2.23	2.24	2.23	2.21

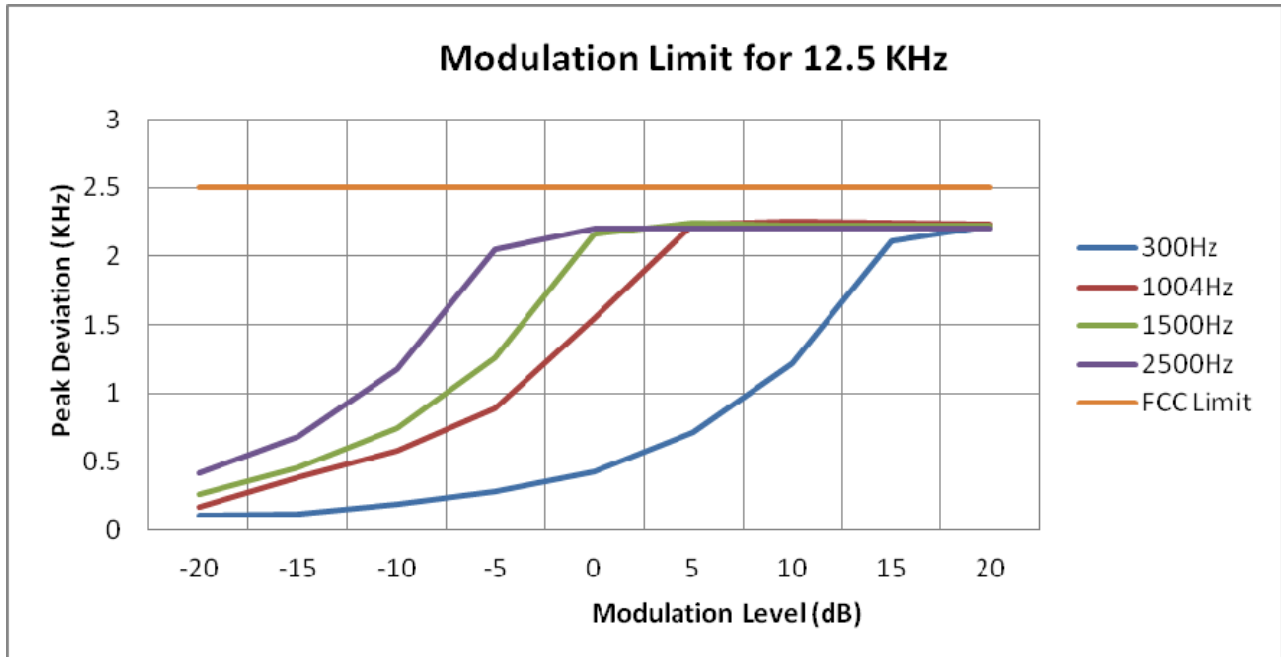

b). Audio Frequency Response:

Rule Part No.: Part 2.1407(a) (b)

Method of Measurement:

The audio frequency response was measured in accordance with TIA/EIA Specification 603 with no exception. A curve or equivalent data showing the frequency response of the audio modulating circuit over a range of 300-3000Hz shall be submitted and Audio Post Limiter Low Pass Filter Response from 3.0 KHz to 50KHz. However, the audio frequency response should test from 100Hz to 5.0 KHz according to FCC Part 90.

Modulation Type: FM

The audio frequency response curve is show below.and

Test Audio Level (1 KHz and 20% maximum deviation) is 2.90mv for 12.5 KHz channel separation.

Note:

- 1 Not applicable to new standard. However, tests are conducted under FCC's recommendation.
- 2 The Audio Frequency Response is identical for 12.5 KHz channel separation

12.5 KHz Channel Separation

Frequency (KHz)	Frequency Deviation (KHz)	1KHz Reference Deviation (KHz)	Audio Frequency Response (dB)
0.1	0.05	0.51	-20.17
0.2	0.05	0.51	-20.17
0.3	0.15	0.51	-12.63
0.4	0.27	0.51	-8.52
0.5	0.25	0.51	-7.19
0.6	0.32	0.51	-4.05
0.7	0.35	0.51	-3.27
0.8	0.38	0.51	-2.56
0.9	0.45	0.51	-1.09
1.0	0.52	0.51	0.17
1.2	0.58	0.51	1.12
1.4	0.64	0.51	1.97
1.6	0.75	0.51	3.35
1.8	0.84	0.51	4.33
2.0	0.92	0.51	5.12
2.2	1.06	0.51	6.35
2.4	1.11	0.51	6.76
2.6	1.20	0.51	7.43
2.7	1.22	0.51	7.58
2.8	1.21	0.51	7.50
3.0	1.27	0.51	7.92
3.5	0.05	0.51	-20.17
4.0	0.04	0.51	-22.11
4.5	0.03	0.51	-24.61
5.0	0.03	0.51	-24.61

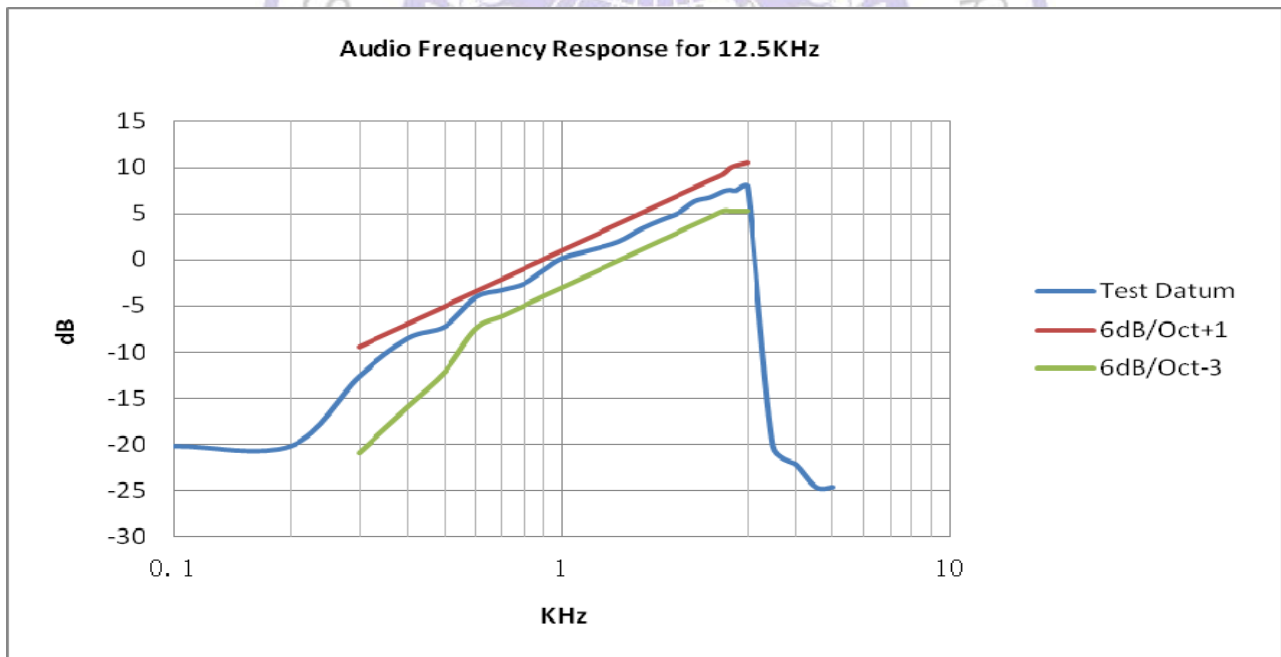

4.6. Frequency Stability Measurement

TEST APPLICABLE

- 1 According to FCC Part 2 Section 2.1055 (a)(1), the frequency stability shall be measured with variation of ambient temperature from -30°C to +50°C centigrade.
- 2 According to FCC Part 2 Section 2.1055 (a) (2), for battery powered equipment, the frequency stability shall be measured with reducing primary supply voltage to the battery operating end point, which is specified by the manufacture.
- 3 Vary primary supply voltage from 85 to 115 percent of the nominal value for other than hand carried battery equipment and tested end point voltage.
- 4 According to §90.213, the frequency stability limit is 2.5 ppm for 12.5 KHz channel separation and 1.0 ppm for 6.25KHz channel separation.

TEST PROCEDURE

The EUT was set in the climate chamber and connected to an external DC power supply. The RF output was directly connected to Spectrum Analyzer ESI 26. The coupling loss of the additional cables was recorded and taken in account for all the measurements. After temperature stabilization (approx. 20 min for each stage), the frequency for the lower, the middle and the highest frequency range was recorded. For Frequency stability Vs. Voltage the EUT was connected to a DC power supply and the voltage was adjusted in the required ranges. The result was recorded.

TEST SETUP BLOCK DIAGRAM

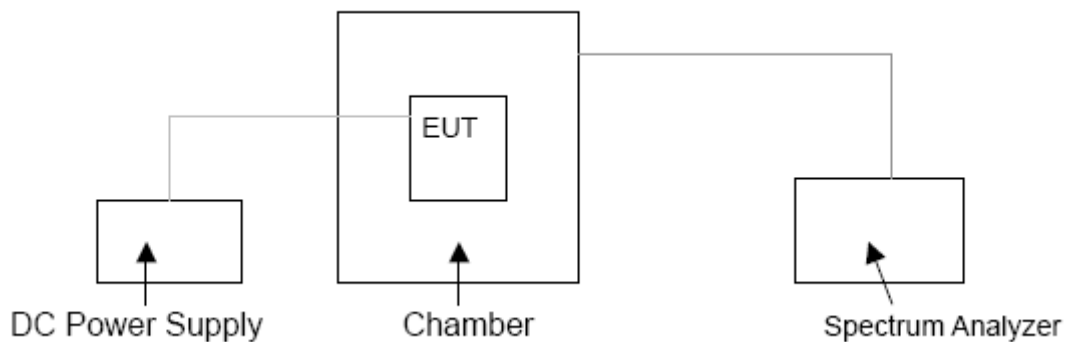

TEST LIMITS

According to 90.213, Transmitters used must have minimum frequency stability as specified in the following table.

Frequency range (MHz)	Fixed and base stations	Mobile stations	
		Over 2 watts output power	2 watts or less output power
Below 25	^{1,2,3} 100	100	200
25-50	20	20	50
72-76	5	-----	50
150-174	^{5,11} 5	⁶ 5	^{4,6} 50
216-220	1.0	-----	1.0
220-222 ¹²	0.1	1.5	1.5
421-512	^{7,11,14} 2.5	⁸ 5	⁸ 5
806-809	¹⁴ 1.0	1.5	1.5
809-824	¹⁴ 1.5	2.5	2.5
851-854	1.0	1.5	1.5
854-869	1.5	2.5	2.5
896-901	¹⁴ 0.1	1.5	1.5
902-928	2.5	2.5	2.5
902-928 ¹³	2.5	2.5	2.5
929-930	1.5	-----	-----
935-940	0.1	1.5	1.5
1427-1435	⁹ 300	300	300
Above 2450 ¹⁰	-----	-----	-----

Modulation Type	Channel Separation	Test conditions		Frequency error (ppm)				
		Voltage(V)	Temp (°C)	450.5000 (MHz)	465.0000 (MHz)	481.0000 (MHz)	496.0000 (MHz)	511.5000 (MHz)
Analog/FM	12.5KHz	7.40	-30	-0.74	-0.71	-0.71	0.70	0.72
			-20	-0.74	-0.69	-0.71	0.70	0.71
			-10	-0.62	-0.69	-0.71	0.63	0.65
			0	-0.55	-0.52	-0.55	0.54	0.57
			10	-0.42	-0.40	-0.41	0.42	0.43
			20	-0.36	-0.33	-0.33	0.34	0.35
			30	-0.36	-0.33	-0.32	0.35	0.32
			40	-0.45	-0.45	-0.41	0.42	0.43
			50	-0.60	-0.45	-0.55	0.50	0.51
		6.35 (End Point)	25	-0.36	-0.36	-0.33	0.30	0.32
		6.29 (85% Rated)	20	-0.36	-0.33	-0.32	0.34	0.37
		8.51 (115% Rated)	20	-0.36	-0.36	-0.32	0.38	0.35
Limit				2.50	2.50	2.50	2.50	2.50
Conclusion				Complies				



4.7. Conducted Output Power

TEST APPLICABLE

Per FCC «2.1046 and «90.205: Maximum ERP is dependent upon the station’s antenna HAAT and required service area.
 Per RSS-119 Section 5.4 and 5.4.1: The output power shall be within ±1.0 dB of the manufacturer’s rated power. Typical transmitter output powers are 110 watts for base and/or fixed stations (paging transmitters excepted), and 30 watts for mobile stations. Higher powers may be certified, but it should be noted that mobile stations are normally only licensed up to 30 watts. See the SRSP relevant to the operating frequency for equipment power limits.

TEST PROCEDURE

Measurements shall be made to establish the radio frequency power delivered by the transmitter the standard output termination. The power output shall be monitored and recorded and no adjustment shall be made to the transmitter after the test has begun, except as noted below:
 If the power output is adjustable, measurements shall be made for the highest and lowest power levels. The EUT connect to the Receiver through 40 dB attenuator.
 Measurement with Spectrum Analyzer FSP40 or Agilent E4407B conducted, external power supply with 12.50 V stabilized supply voltage.

TEST CONFIGURATION

EUT	Attenuator	Spectrum Analyzer/Receiver
-----	------------	----------------------------

The EUT was directly connected to a RF Communication Test set by a 20 dB attenuator

TEST RESULTS

Frequency Range (MHz)	Modulation Type	Channel Separation (KHz)	Test Channel	Maximum Output Power Test Results (dBm)
450-512	Analog/FM	12.5	A001	36.33
			A002	36.49
			A003	36.73
			A004	36.68
			A005	36.56
Limit	FCC:The limit is dependent upon the station’s antenna HAAT and required service area.			
Test Results	Compliance			

Plots of Maximum Transmitter Power Measurement

Modulation Type	Channel Separation	Freq.(MHz)	Rated Power (Watt)	Measurement (dBm)	FCC Limit	Results
FM	12.5 KHz	450.5000	5	36.33	Varies	Compliance

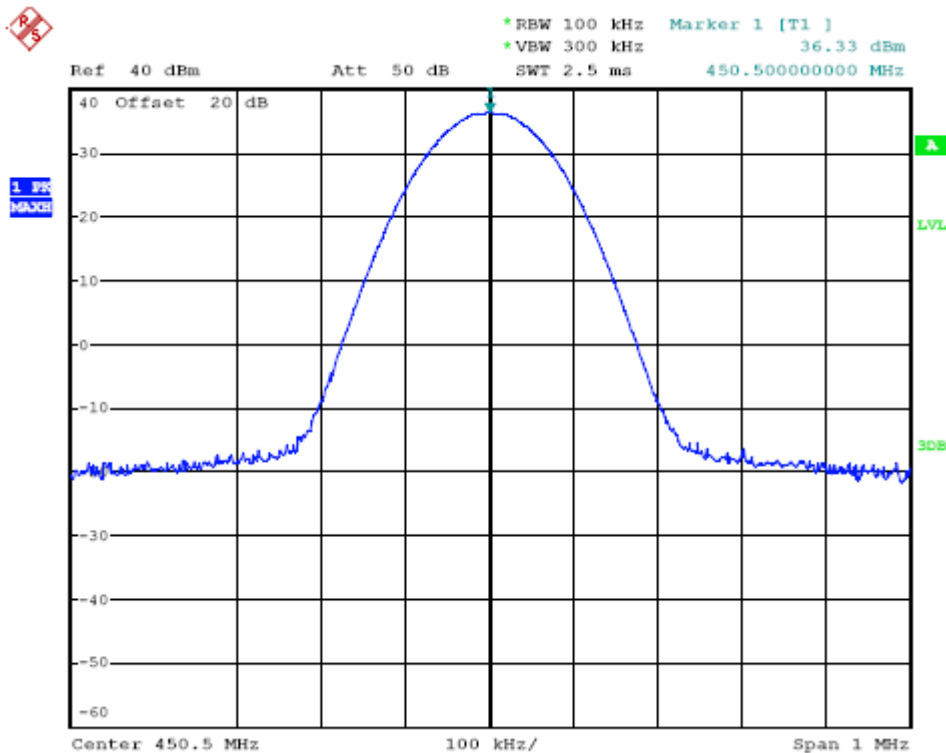

Modulation Type	Channel Separation	Freq.(MHz)	Rated Power (Watt)	Measurement (dBm)	FCC Limit	Results
FM	12.5 KHz	465.0000	5	36.49	Varies	Compliance

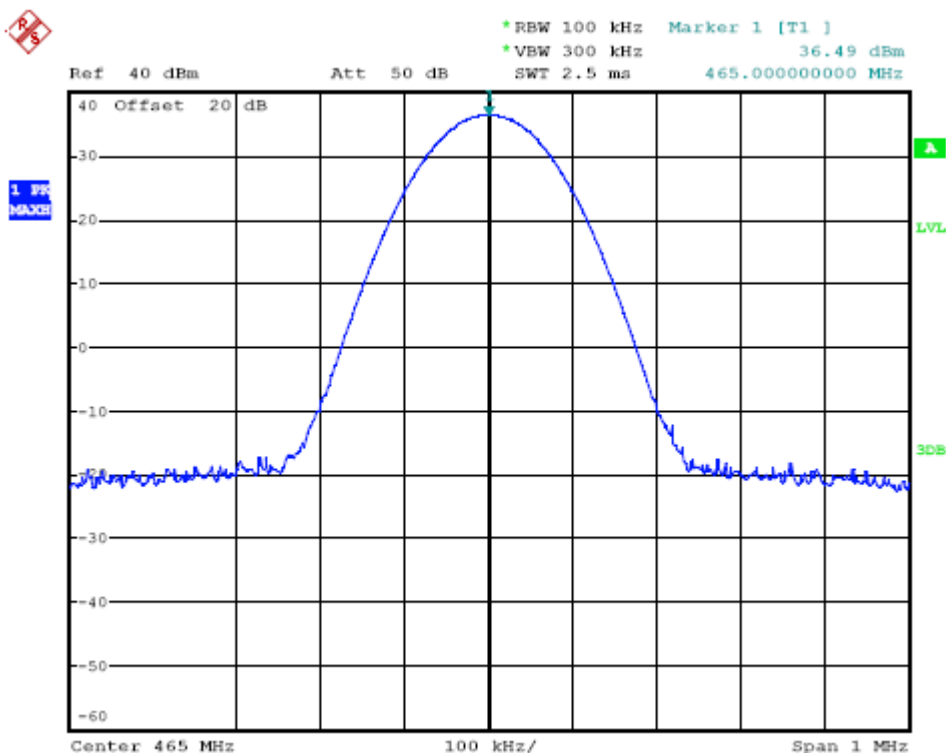

Modulation Type	Channel Separation	Freq.(MHz)	Rated Power (Watt)	Measurement (dBm)	FCC Limit	Results
FM	12.5 KHz	481.0000	5	36.73	Varies	Compliance

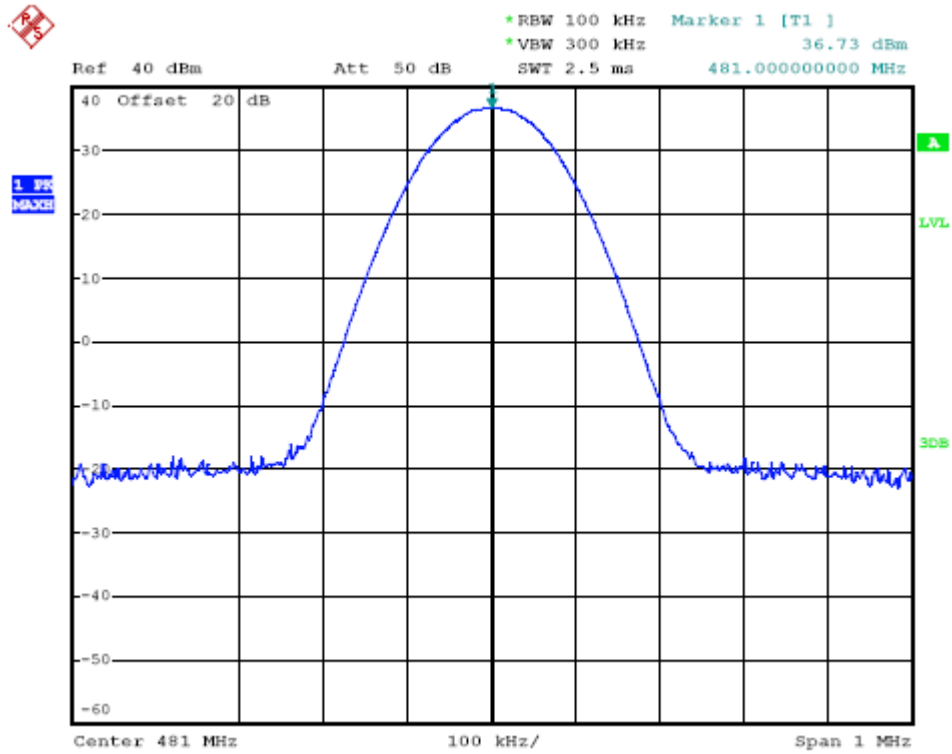

Modulation Type	Channel Separation	Freq.(MHz)	Rated Power (Watt)	Measurement (dBm)	FCC Limit	Results
FM	12.5 KHz	496.0000	5	36.68	Varies	Compliance

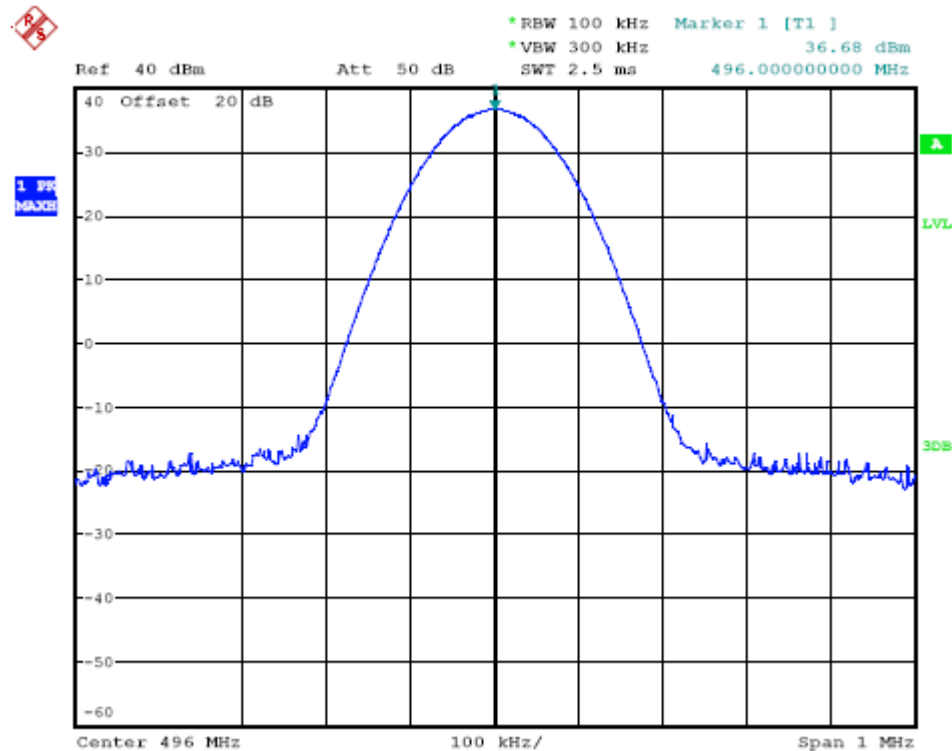

Modulation Type	Channel Separation	Freq.(MHz)	Rated Power (Watt)	Measurement (dBm)	FCC Limit	Results
FM	12.5 KHz	511.5000	5	36.56	Varies	Compliance

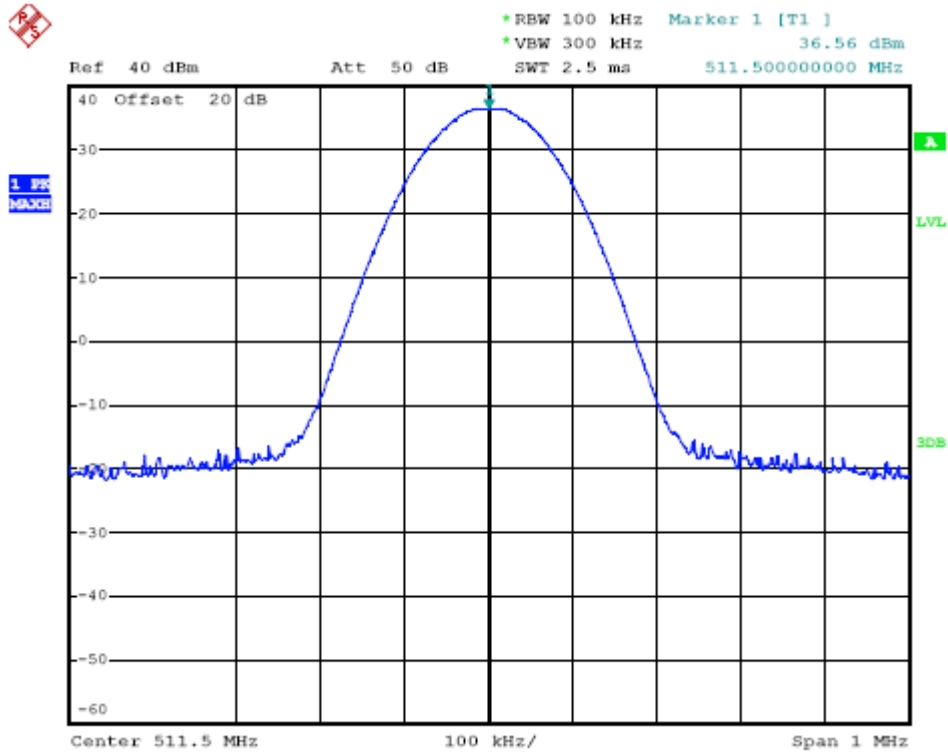

4.8. Transmitter Frequency Behavior

TEST APPLICABLE

Section 90.214

Transient frequencies must be within the maximum frequency difference limits during the time intervals indicated:

Time intervals ^{1, 2}	Maximum frequency difference ³	All equipment	
		150 to 174 MHz	421 to 512MHz
Transient Frequency Behavior for Equipment Designed to Operate on 25 KHz Channels			
t ₁ ⁴	± 25.0 KHz	5.0 ms	10.0 ms
t ₂	± 12.5 KHz	20.0 ms	25.0 ms
t ₃ ⁴	± 25.0 KHz	5.0 ms	10.0 ms
Transient Frequency Behavior for Equipment Designed to Operate on 12.5 KHz Channels			
t ₁ ⁴	± 12.5 KHz	5.0 ms	10.0 ms
t ₂	± 6.25 KHz	20.0 ms	25.0 ms
t ₃ ⁴	± 12.5 KHz	5.0 ms	10.0 ms
Transient Frequency Behavior for Equipment Designed to Operate on 6.25 KHz Channels			
t ₁ ⁴	±6.25 KHz	5.0 ms	10.0 ms
t ₂	±3.125 KHz	20.0 ms	25.0 ms
t ₃ ⁴	±6.25 KHz	5.0 ms	10.0 ms

- t_{on} is the instant when a 1 KHz test signal is completely suppressed, including any capture time due to phasing.
 t₁ is the time period immediately following t_{on}.
 t₂ is the time period immediately following t₁.
 t₃ is the time period from the instant when the transmitter is turned off until t_{off}.
 t_{off} is the instant when the 1 KHz test signal starts to rise.
- During the time from the end of t₂ to the beginning of t₃, the frequency difference must not exceed the limits specified in § 90.213.
- Difference between the actual transmitter frequency and the assigned transmitter frequency.
- If the transmitter carrier output power rating is 6 watts or less, the frequency difference during this time period may exceed the maximum frequency difference for this time period.

TEST PROCEDURE

TIA/EIA-603 2.2.19

TEST CONFIGURATION

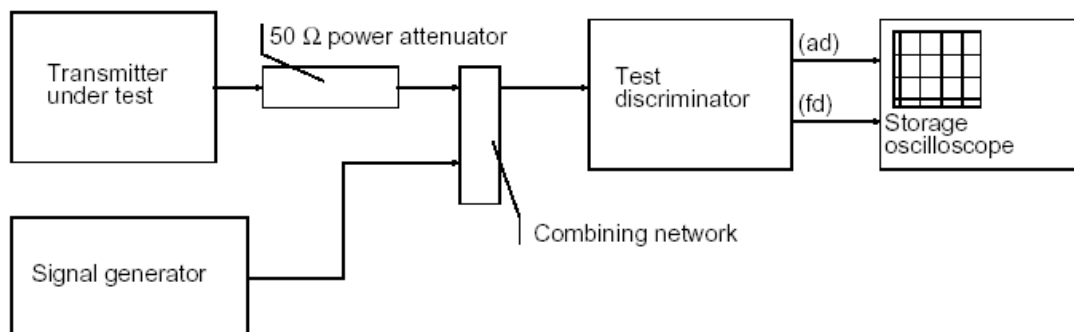

TEST RESULTS

Please refer to the following plots.

Modulation Type: FM

Transmitter Frequency Behaviour @ 12.5 KHz Channel Separation-----Off – On

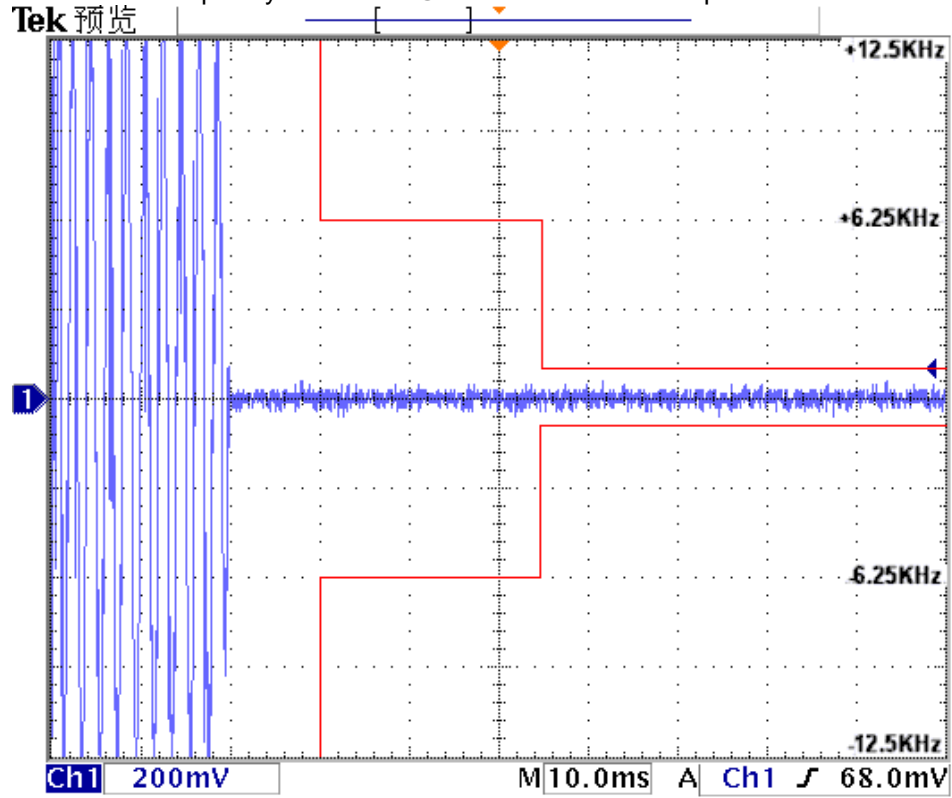

Transmitter Frequency Behaviour @ 12.5 KHz Channel Separation-----On - Off

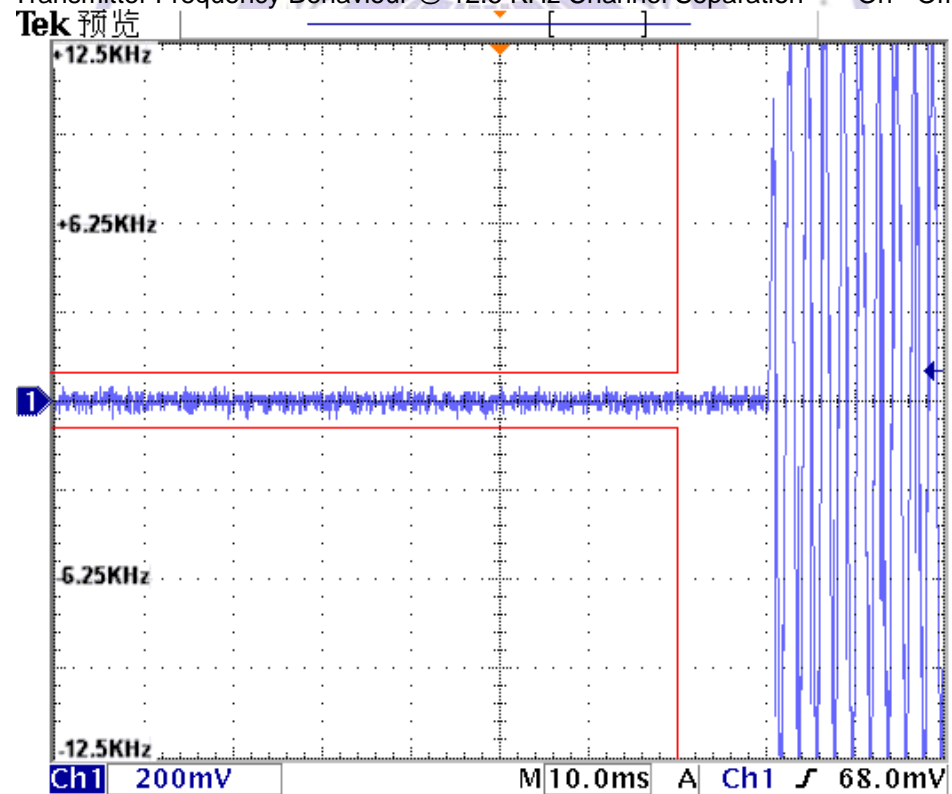

5. Test Setup Photos of the EUT

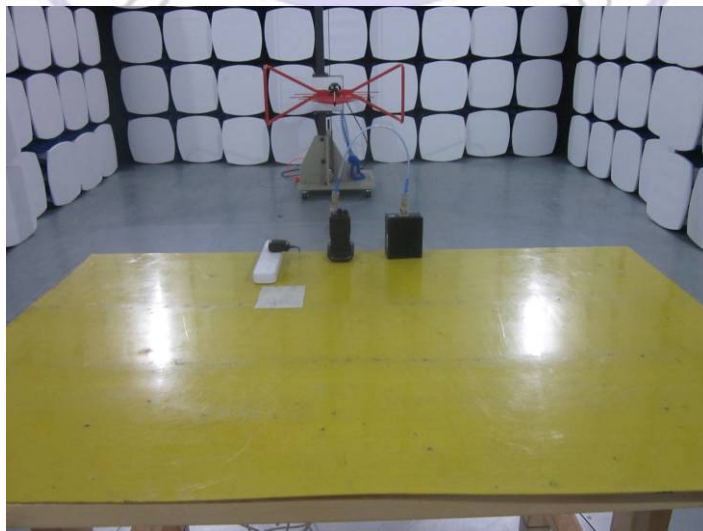
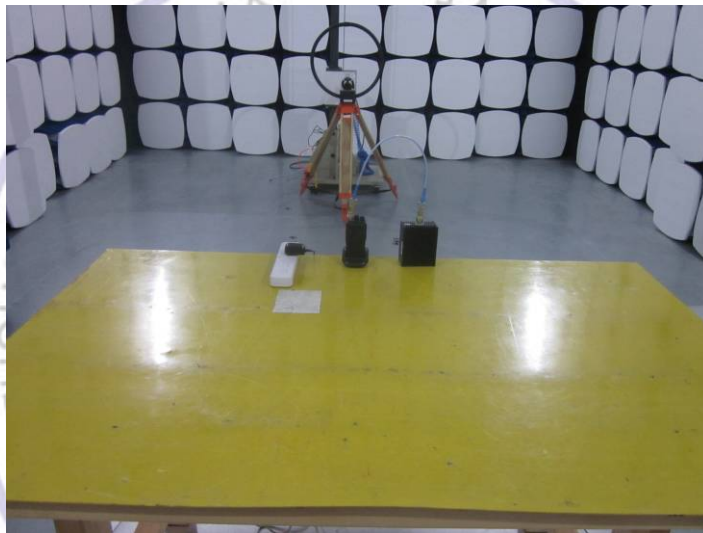

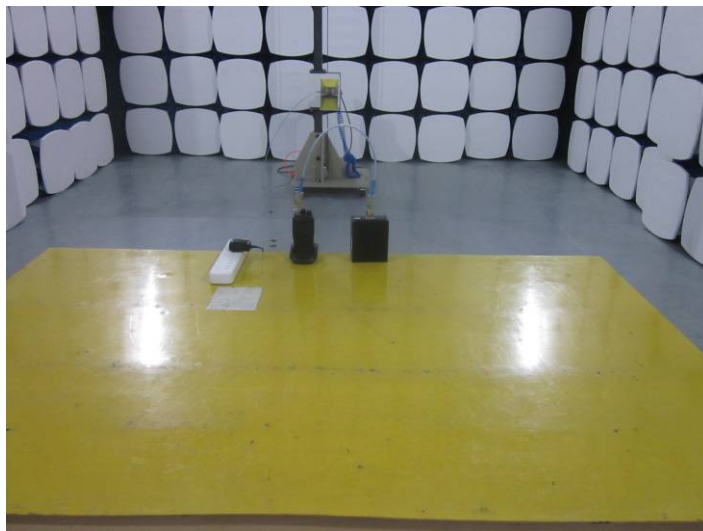

6. External and Internal Photos of the EUT

External Photos







Internal Photos

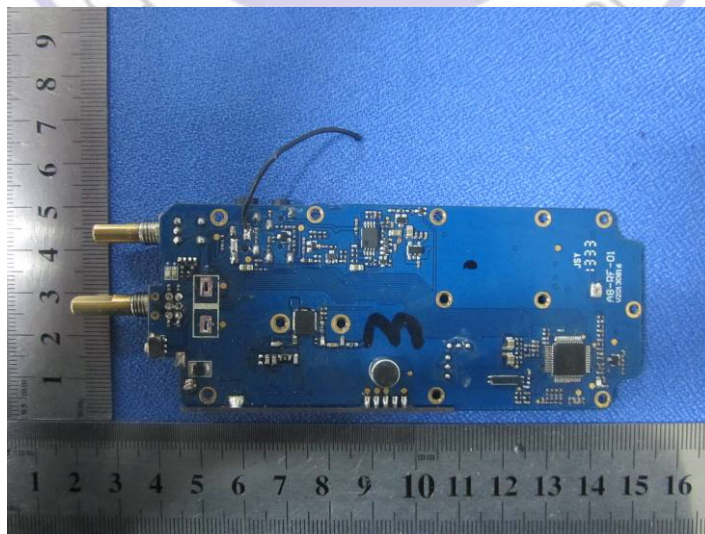

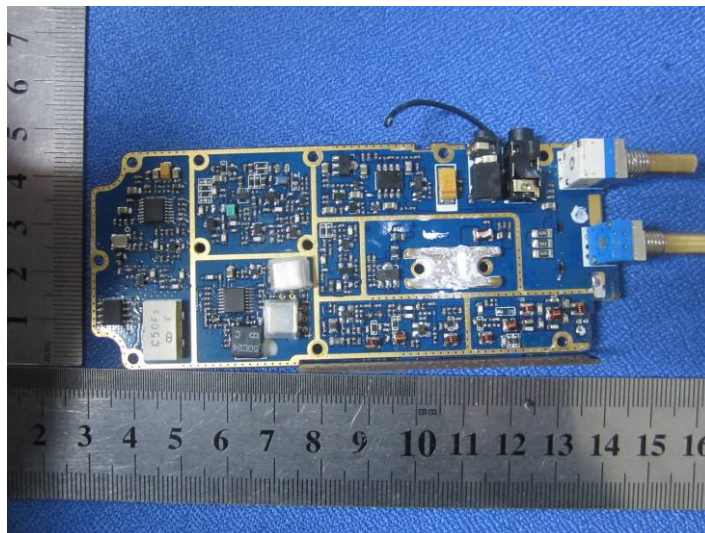

.....End of Report.....

