

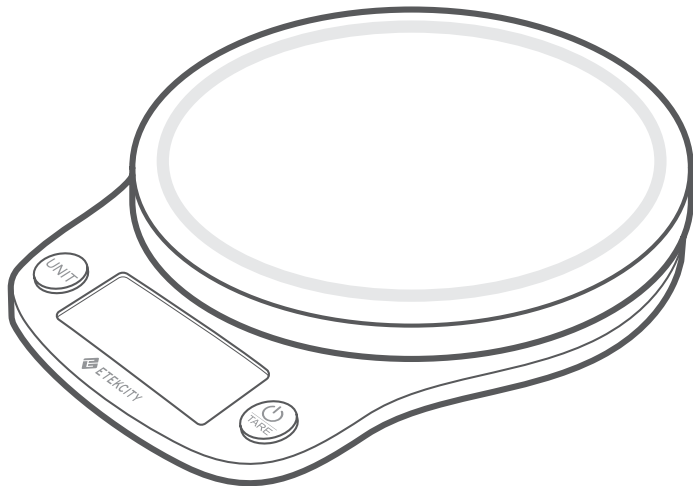

Smart Nutrition Scale

Model: ESN90



Thank you for purchasing the
Smart Nutrition Scale by Etekcity.

If you have any questions or concerns, please reach out to our helpful Customer Support Team at [**support@etekcity.com**](mailto:support@etekcity.com).
We hope you enjoy your new smart nutrition scale!

BECOME AN ETEKCITIZEN

Get exclusive deals, giveaways, and product registration.
Better products for better living. Find us at [**etekcity.com**](https://etekcity.com)

Table of Contents

Package Contents	3
Specifications	3
Safety Information	4
Function Diagram	5
Digital Display	5
Setup	6
VeSync App Configuration	7
Scale Operation	8
• Tips	8
• Measurement	8
• Tare Function	9
Maintenance	10
Troubleshooting	11
Warranty Information	13
Customer Support	14

Package Contents

1 x Smart Nutrition Scale
3 x 1.5V AAA Batteries (Pre-Installed)
1 x Quick Start Guide

Specifications

Weight Capacity	176.4 oz / 11 lb / 5000 g / 5000 mL
Units	oz / lb:oz / fl'oz (water/milk) / g / mL (water/milk)
Backlight Auto-Off	30-120 seconds (adjustable in app)
Scale Auto-Off	120 seconds
Dimensions	8.1 x 6.5 x 1.3 in / 207 x 166 x 34 mm
Battery	3 x 1.5V AAA batteries

Increments

Measurement Unit	Item Weight	Increment
g	< 1000 g	0.1 g
	1000-5000 g	1 g
oz	< 35 oz	0.01 oz
	35-176 oz	0.05 oz

Safety Information

To avoid damage to this scale, please read and follow all instructions and safety guidelines in this manual.

Scale

- **Do not** exceed the 11 lb / 5000 g weight capacity, as doing so may damage the scale. An overload indicator will appear on the LCD display if the limit is exceeded.
- Smart scales are not waterproof. **Do not** immerse the scale in water or any liquid. If liquid is spilled on the digital display or buttons, immediately wipe the scale clean with a soft cloth to avoid internal damage.
- Handle with care. This scale is not intended for commercial or heavy-duty use.
- Keep the scale in a cool, dry place. Avoid exposing to damp environments or extreme temperatures.
- Household use **only**.

Batteries

- **Do not** mix new and old batteries.
- If the low battery indicator (“”) appears on the display, replace the batteries.
- If the scale is not in use for an extended period of time, remove the batteries to conserve battery life and extend the lifetime of the scale.

**SAVE THESE
INSTRUCTIONS**

Function Diagram

- A. Weighing Platform
- B. Unit Selection Button
- C. Digital Display
- D. Power/Tare Button
- E. Anti-Skid Pads
- F. Battery Compartment

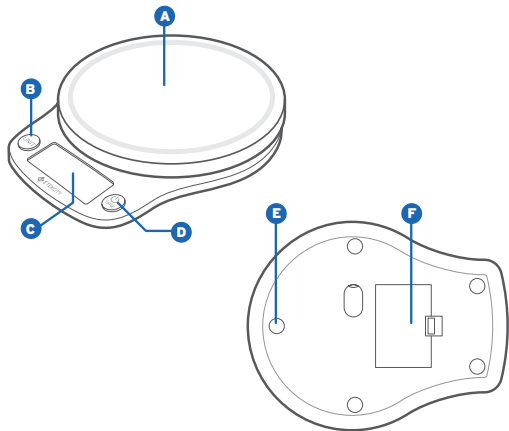

Digital Display

- A. Bluetooth® Mode
- B. Weighing Mode
- C. Measurement Unit
- D. Tare Mode
- E. Negative Weight Value
- F. Weight Value

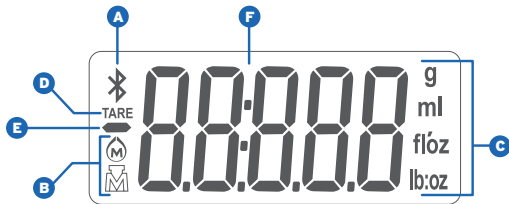

Setup

Before first use, remove the plastic strip from the battery compartment. *[Figure 1.1]*

1. Open the battery compartment on the underside of the scale.
2. If necessary, insert the included AAA batteries, making sure they are under the correct polarity as marked in the battery compartment.

[Figure 1.2]

3. Replace the battery cover.
4. Press  to turn on the scale.

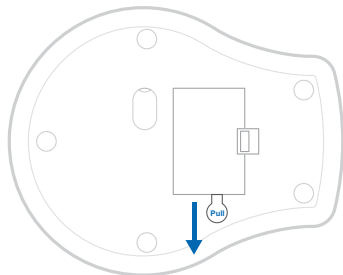

Figure 1.1

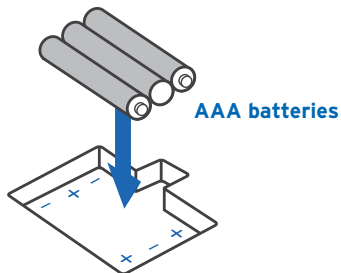

Figure 1.2

VeSync App Configuration

Note: Due to ongoing updates and improvements, the VeSync app may be slightly different than shown in the manual. In case of any differences, follow the in-app instructions.

1. To download the VeSync app, scan the QR code or search “VeSync” in the Apple App Store® or Google Play™ Store.

Note: For Android™ users, choose “**Allow**” to use VeSync.

2. Open the VeSync app. If you already have an account, tap **Log In**. To create a new account, tap **Sign Up**.

Note: You must create your own VeSync account to use third-party services and products. These will not work with a guest account. With a VeSync account, you can also allow your family or friends to use your nutrition scale. Even if you get a new phone, your nutrition records will still be available on your VeSync account.

3. Tap **+** and follow the in-app instructions to add your smart scale.

Note:

- Make sure your phone's Bluetooth® is turned on in your phone settings.
- For Android users, make sure your Location is turned on as well.







Scale Operation

Note: You can use the VeSync app to operate your scale, and for additional features such as extra settings, food records, tracking nutrition goals, and more.

Tips

- For accurate results, always place the scale on a hard, dry, flat surface, and keep the scale away from dirt, dust, vibration, wind, air currents, and electromagnetic interference.
- When you turn on the scale, choose units, or use the Tare function, always wait for the scale to read "0" before attempting measurement.

Measurement

1. Press  to turn on the scale. Press **UNIT** to select your desired measuring unit, which will show at the top of the display.
 - a. **Weight:** Choose between ounces ("oz"), both pounds and ounces ("lb:oz"), or grams ("g").
 - b. **Volume:** Scale measures in fluid ounces ("fl'oz") and milliliters ("ml"). Select water  or milk  options.
2. **Optional:** If you're using a container to hold the items or liquid you're measuring, first place the empty container on the scale. Press  to zero out (tare) the container's weight (see **Tare Function**, page 9).
3. Gently place your item on the scale. The display will show the weight or volume.

4. Press and hold  for 2 seconds to turn off the scale.

Note:

- To reset the scale, remove all weight from the platform and press .
- To conserve battery power, the scale will automatically turn off after 2 minutes of inactivity. The display backlight will automatically turn off after 30 seconds of inactivity. You can change these settings in the VeSync app.

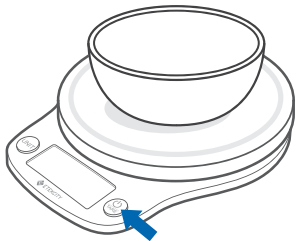



Figure 2.1

Tare Function

Whenever you measure liquid or items inside a container, you can use the Tare function to remove the container's weight from the final measurement.

1. Place an empty container on the scale. The display will show the container's weight.
2. Press . The display will show "0.00" again. *[Figure 2.1]*
3. Place liquid or items in the container. The scale will now measure the liquid or items without including the weight of the container.
4. When you're done, reset the scale by removing all weight and pressing .

Maintenance

- Use a slightly damp cloth to clean the surface of the scale, followed by a dry, soft cloth to wipe away the remaining moisture.
- You can use a dry, soft cloth to wipe dust off the scale.
- **Do not** wash the scale or immerse it in water or any other liquid.

Troubleshooting

Problem	Possible Solution
LCD display is dim.	Scale may be on standby. Place an item on the scale for measurement, or turn off the scale by pressing and holding  for 2 seconds.
	Replace the batteries.
LCD display shows “LO”.	Battery is low. Replace the batteries.
Scale does not turn on.	Replace the batteries.
	Insert batteries under the correct polarity as marked in the battery compartment.
Scale cannot connect to VeSync app.	Make sure your mobile device is within 30 ft / 10 m of the scale.
	A Bluetooth device can only exchange data with 1 other Bluetooth device at a time. Make sure the scale is not currently connected to any other phone or app.
Display shows “Err”.	Weight exceeds 176.4 oz / 11 lb / 5000 g / 5000 mL. Promptly remove item from scale to protect its weight sensors. Use a different scale with a higher weight range.

If you still need help, please contact **Customer Support** (page 14).

FCC Statement

This device complies with Part 15 of the FCC Rules. Operation is subject to the following two conditions:

(1) This device may not cause harmful interference, and

(2) This device must accept any interference received, including interference that may cause undesired operation.

Any changes or modifications not expressly approved by the party responsible for compliance could void the user's authority to operate this equipment.

This equipment has been tested and found to comply with the limits for a Class B digital device, pursuant to Part 15 of the FCC Rules. These limits are designed to provide reasonable protection against harmful interference in a residential installation.

This equipment generates, uses and can radiate radio frequency energy and, if not installed and used in accordance with the instructions, may cause harmful interference to radio communications. However, there is no guarantee that interference will not occur in a particular installation. If this equipment does cause harmful interference to radio or television reception, which can be determined by turning the equipment off and on, the user is encouraged to try to correct the interference by one of the following measures:

- Reorient or relocate the receiving antenna.
- Connect the equipment into an outlet on a circuit different from that to which the receiver is connected.
- Increase the separation between the equipment and receiver.
- Consult the dealer or an experienced radio/TV technician for help.

FCC Radiation Exposure Statement

This equipment complies with FCC radiation exposure limits set forth for an uncontrolled environment. End users must follow the specific operating instructions for satisfying RF exposure compliance. To maintain compliance with FCC RF exposure compliance requirements, please follow operation instructions as documented in this manual. This transmitter must not be co-located or operating in conjunction with any other antenna or transmitter. This equipment should be installed and operated with a minimum distance of 20 cm between the radiator and your body. The availability of some specific channels and/or operational frequency bands are country dependent and are firmware programmed at the factory to match the intended destination. The firmware setting is not accessible by the end user.

Warranty Information

Product Name	Smart Nutrition Scale
Model	ESN90
For your own reference, we strongly recommend that you record your order ID and date of purchase.	
Order ID	
Date of Purchase	

Terms & Policy

Etekciti Corporation (“Etekciti”) warrants this product to the original purchaser to be free from defects in material and workmanship, under normal use and conditions, for a period of one year from the date of original purchase.

Etekciti agrees, at our option during the warranty period, to repair any defect in material or workmanship or furnish an equal product in exchange without charge, subject to verification of the defect or malfunction and proof of the date of purchase.

There is no other express warranty. This warranty does not apply:

- If the product has been modified from its original condition;
- If the product has not been used in accordance with directions and instructions in the user manual;
- To damages or defects caused by accident, abuse, misuse or improper or inadequate maintenance;

- To damages or defects caused by service or repair of the product performed by an unauthorized service provider or by anyone other than Etekciti;
- To damages or defects occurring during commercial use, rental use, or any use for which the product is not intended;
- To damages or defects exceeding the cost of the product.

Etekciti will not be liable for indirect, incidental, or consequential damages in connection with the use of the product covered by this warranty.

This warranty extends only to the original consumer purchaser of the product and is not transferable to any subsequent owner of the product regardless of whether the product is transferred during the specified term of the warranty.

This warranty does not extend to products purchased from unauthorized sellers. Etekciti's warranty extends only to products purchased from authorized sellers that are subject to Etekciti's quality controls and have agreed to follow its quality controls.

All implied warranties are limited to the period of this limited warranty.

This warranty gives you specific legal rights and you may also have other rights which vary from state to state. Some states do not allow the exclusion or limitation of incidental or consequential damages, so the above limitation or exclusion may not apply to you.

If you discover that your product is defective within the specified warranty period, please contact Customer Support via **support@etekcity.com**. **DO NOT** dispose of your product before contacting us. Once our Customer Support Team has approved your request, please return the product with a copy of the invoice and order ID.

Warranty Information (cont.)

Extend Your Warranty by 1 Year

Register your product within 14 days of purchase at www.etekcity.com/warranty to extend your 1-year warranty by an additional year.

This warranty is made by:

Etekcity Corporation
1202 N. Miller St. Suite A
Anaheim, CA 93806

Attributions

Android and Google Play are trademarks of Google LLC.

Apple App Store is a trademark of Apple Inc.

The Bluetooth® word mark and logos are registered trademarks owned by Bluetooth SIG, Inc. and any use of such marks by Etekcity Corporation is under license.

Customer Support

If you have any questions or concerns about your new product, please contact our helpful Customer Support Team.

Etekcity Corporation

1202 N. Miller St., Suite A
Anaheim, CA 92806

Email: support@etekcity.com

Toll-Free: (855) 686-3835

Support Hours

Mon-Fri, 9:00 am-5:00 pm PST/PDT

**Please have your order invoice and order ID ready before contacting Customer Support.*

Connect with us @Etekcity



