

Carewell Electric Technology (Zhongshan) Co., Ltd.

Model #:DF71T+DC8-116MR (with light function)

DC POWER CEILING FAN
REMOTE CONTROL
INSTRUCTION MANUAL AND
INSTALLATION INSTRUCTIONS

Input: 120VAC 60Hz power supply only
Output: 50W (Max.) for Motor
60W (Max) for Light (LED)
Operating Range: Approx 10 Meters

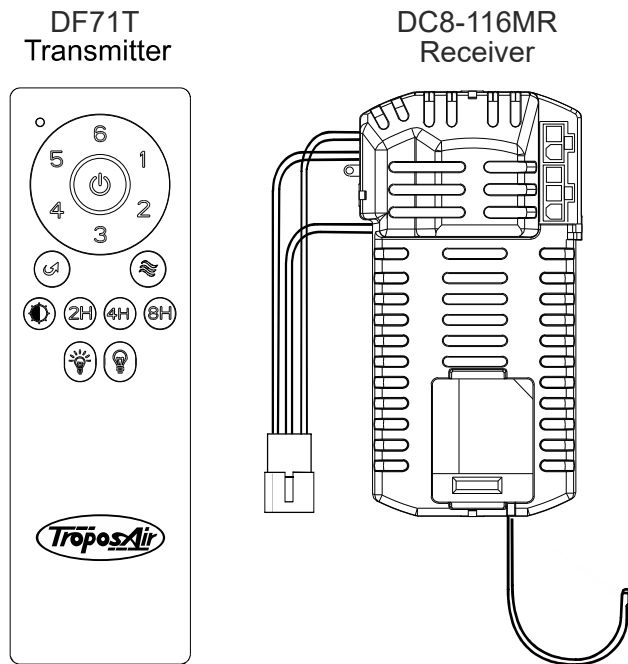

Important: Using a wall dimmer switch to control fan speed will damage the fan. To reduce the risk of fire or electrical shock, do not use any type of variable wall control in line to the remote receiver or to control fan speed.

1. Switch power off at fuse box or circuit breaker before you begin installing the fan.
2. Make wiring connections as indicated Fig. 1. If more than one fan is being installed refer to last page for special considerations.

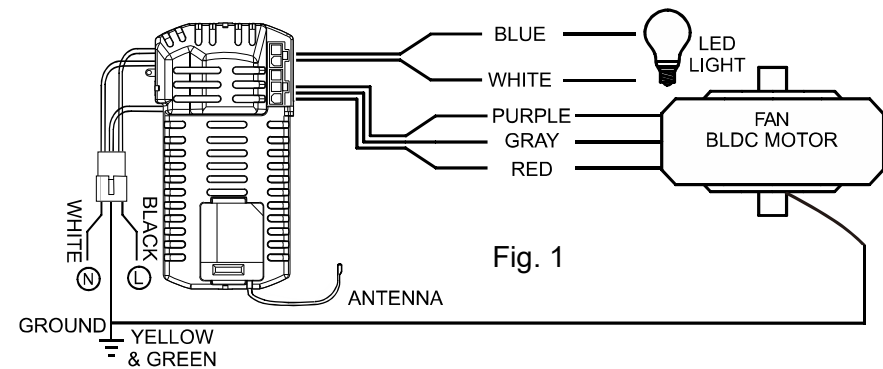

REMOTE CODE SETTING PROCESS

Pairing Receiver to Transmitter:

Step 1): Insert the 2pcs of batteries into transmitter,with the fan power off. (Fig. 2)

Step 2): Within 60 seconds of restoring power to the fan, use a ball point pen or small tool to press LEARN button 5 seconds. Once the receiver has learned the communication code from the transmitter, the light fixture will blink twice to indicate the pairing was successful.

NOTE (1): After the AC power is on, do not press any other button on the remote control before pairing process. Doing so will cause the procedure to fail.

NOTE (2): After completing the steps above,you should be able to operate the ceiling fan. If the fan is not responding to the remote control,please turn the power off to the receiver, and repeat Step 2).

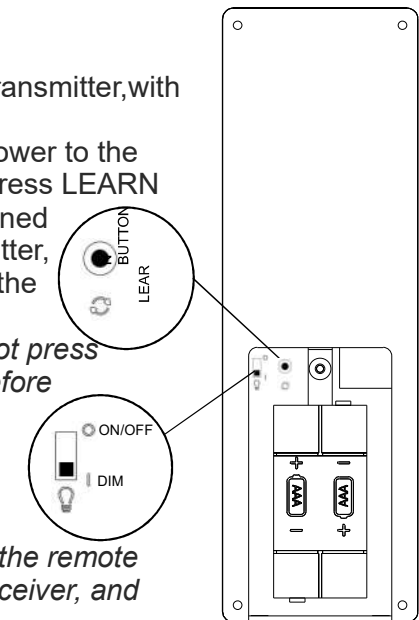

Fig. 2

- Smart app instructions:
HOW TO CONNECT TO WiFi
MODULE?

Download the latest smart Life app and follow the instruction:

Smart Phone turned on WiFi Location Open Smart Life APP Add Device → Small Home Appliance → FAN(WiFi) → Select 2.4GHz WiFi and input password → App will show Confirm device blinking page... → Press and hold "power" button 5 seconds to enter WiFi pairing mode. → Press the Confirm device blinking button in the app. → Wait 3 Seconds for success beep. → Connecting Device.

LIGHT FUNCTION SELECT SWITCH

The light function select switch should stay in the DIM setting unless the light fixture has replaceable bulbs and is using non-dimmable LED or CFL bulbs. (Fig. 2)

FUNCTIONS OF REMOTE CONTROL



Turn off the ceiling fan.

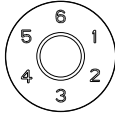

Fan speed: Press and release immediately to turn on and set fan speed.



Forward/Reverse button: Changes direction of blade rotation after stopping fan momentarily.



Natural Wind button: Creates a gentle sea-breeze effect by varying the fan speed slightly.



Light On/Off button: Toggles light fixture on/off. Also changes color temperature if toggled within 7 seconds.



Timer button: Fan will turn off after 2/4/8 hours.



Light Dimmer Up button (LEFT): Long-press to increase the brightness of the light fixture, short-press to toggle light fixture on/off.



Light Dimmer Down button (RIGHT): Long-press to decrease the brightness of the light fixture, short-press to toggle light fixture on/off.

INSTALLING WALL MOUNTED HOLDER

Attach wall mounted holder using the two mounting screws.

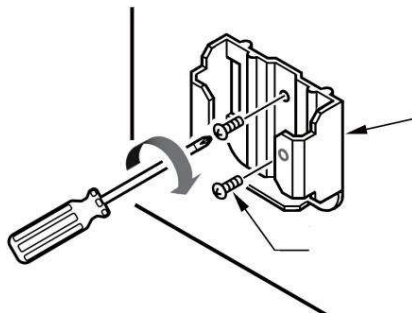

Warning: Changes or modifications to this unit not expressly approved by the party responsible for compliance could void the user's authority to operate the equipment.

This device complies with Part 15 of the FCC Rules.

Operation is subject to the following two conditions:

- (1) this device may not cause harmful interference, and
- (2) this device must accept any interference received, including interference that may cause undesired operation.

Note: This equipment has been tested and found to comply with the limits for a Class B digital device, pursuant to part 15 of the FCC Rules. These limits are designed to provide reasonable protection against harmful interference in a residential installation. This equipment generates, uses and can radiate radio frequency energy and, if not installed and used in accordance with the instructions, may cause harmful interference to radio communications. However, there is no guarantee that interference will not occur in a particular installation. If this equipment does cause harmful interference to radio or television reception, which can be determined by turning the equipment off and on, the user is encouraged to try to correct the interference by one or more of the following measures:

- Reorient or relocate the receiving antenna.
- Increase the separation between the equipment and receiver.
- Connect the equipment into an outlet on a circuit different from that to which the receiver is connected.
- Consult the dealer or an experienced radio/TV technician for help.