

90.00 mm

80.00 mm

Quick Start Guide

OtterBox Charging Pad

OBFTC-0094-A, 78-80537, 78-80563,
78-80632, and 78-80633

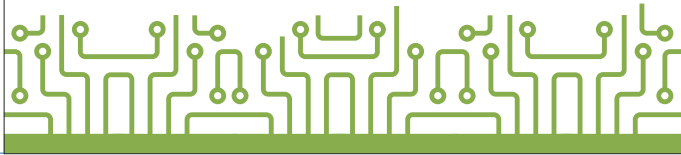

90.00 mm

80.00 mm

Unpacking

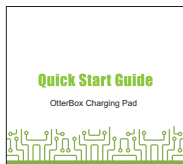

Quick Start Guide

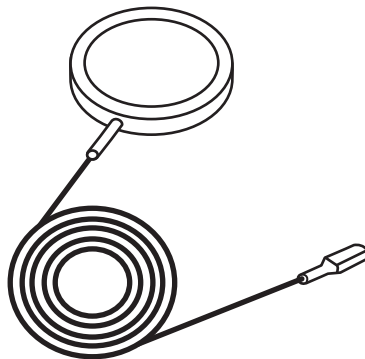

02

90.00 mm

80.00 mm

Components

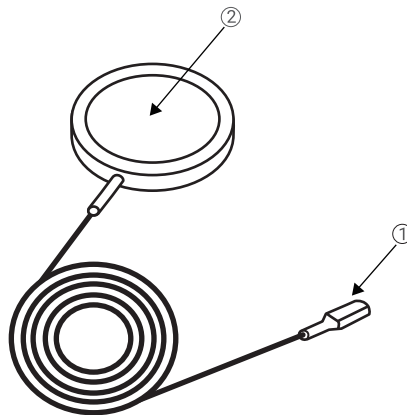

- ① USB-C Port
- ② Charging Pad

90.00 mm

80.00 mm

Charging your device

1

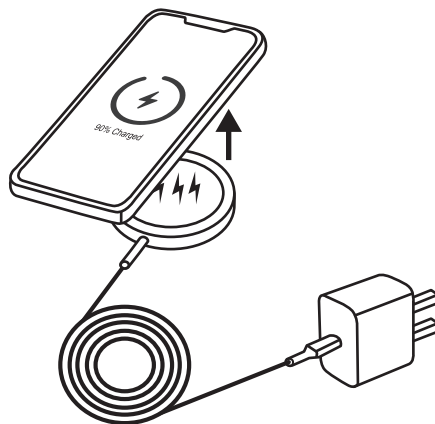

04

90.00 mm

80.00 mm

Charging your device

2

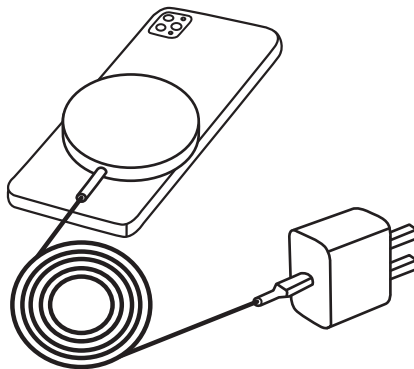

90.00 mm

80.00 mm

Specification

Input	5V/3A 9V/2.22A 12V/1.67A
Output	5Wireless 15W (Max)
Size Dimensiones	56.0x56.0x5.6mm
Weight	61.0g
Temperature	Operating Temp: 0°C~ +35°C Storage Temp.: -20°C~ +70°C

Manufacturer:

Company Name: DONGGUAN KETAIHONG ELECTRONICS CO.,LTD

Address : Second Industrial Zone, Shujiu Village, Changping Town,
523569 Dongguan, Guangdong, PEOPLE'S REPUBLIC OF CHINA

Contact



For more information, please visit:
<https://www.otterbox.com>

90.00 mm

80.00 mm

Attention / Atención



Do not expose products to excessive heat (e.g. from storage in direct sunlight, fire or the like).



Do not try to take the product apart. It may cause serious damage



Do not drop or knock the product on hard surfaces.



Do not use chemicals or detergents to clean the product.



Use the original cable or certified cables.

WARNING – Do not hang any type of accessory or accessory bracket from the plug

90.00 mm

80.00 mm

Warranty

FCC Statement

Federal Communication Commission Interference Statement

This equipment has been tested and found to comply with the limits for a Class B digital device, pursuant to Part 15 of the FCC Rules. These limits are designed to provide reasonable protection against harmful interference in a residential installation. This equipment generates, uses, and can radiate radio frequency energy and, if not installed and used in accordance with the instructions, may cause harmful interference to radio communications. However, there is no guarantee that interference will not occur in a particular installation. If this equipment does cause harmful interference to radio or television reception, which can be determined by turning the equipment off and on, the user is encouraged to try to correct the interference by one or more of the following measures:

- Reorient or relocate the receiving antenna.
- Increase the separation between the equipment and receiver.
- Connect the equipment into an outlet on a circuit different from that to which the receiver is connected.
- Consult the dealer or an experienced radio/TV technician for help.

FCC Caution:

This device complies with Part 15 of the FCC Rules. Operation is subject to the following two conditions: (1) This device may not cause harmful interference, and (2) this device must accept any interference received, including interference that may cause undesired operation.

Non-modification Statement:

Changes or modifications not expressly approved by the party responsible for compliance could void the user's authority to operate the equipment.

Radiation Exposure Statement

This equipment complies with FCC radiation exposure limits set forth for an uncontrolled environment. This equipment should be installed and operated with minimum distance 20cm between the radiator and your body.

90.00 mm

80.00 mm

Warranty

ISED Statement

This device complies with Industry Canada licence-exempt RSS standard(s).
Operation is subject to the following two conditions:

- (1) This device may not cause interference, and
- (2) This device must accept any interference, including interference that may cause undesired operation of the device.

Radiation Exposure Statement

This equipment complies with Canada radiation exposure limits set forth for an uncontrolled environment. This equipment should be installed and operated with minimum distance 10cm between the radiator & your body.

L'émetteur/récepteur exempt de licence contenu dans le présent appareil est conforme aux CNR d'Innovation, Sciences et Développement économique Canada applicables aux appareils radio exempts de licence. L'exploitation est autorisée aux deux conditions suivantes :

- (1) L'appareil ne doit pas produire de brouillage;
- (2) L'appareil doit accepter tout brouillage radioélectrique subi, même si le brouillage est

susceptible d'en compromettre le fonctionnement.

Déclaration d'exposition aux radiations

Cet équipement est conforme Canada limites d'exposition aux radiations dans un environnement non contrôlé. Cet équipement doit être installé et utilisé à distance minimum de 20cm entre le radiateur et votre corps.