



SAR Test Report

Report No.: AGC00575130901FH01

FCC ID : 2AAYEWOW818

PRODUCT DESIGNATION : CDMA Smart phone

APPLICATION PURPOSE : Original Equipment

BRAND NAME : WOW

MODEL NAME : WOW 818

CLIENT : MobilMax Technology Inc.

DATE OF ISSUE : Sep.18, 2013

STANDARD(S) : IEEE Std.1528:2003
47CFR§2.1093
IEEE/ANSI C95.1

REPORT VERSION : V1.0

Attestation of Global Compliance(Shenzhen) Co., Ltd.



CAUTION:

This report shall not be reproduced except in full without the written permission of the test laboratory and shall not be quoted out of context.

Report Revise Record

Report Version	Revise Time	Issued Date	Valid Version	Notes
V1.0	/	Sep.18, 2013	Valid	Original Report

<h1>Test Report Certification</h1>	
Applicant Name	MobilMax Technology Inc.
Applicant Address	2F-5, No. 28, Tai-Yuan St., Chupei City, HsinChu County 302, Taiwan
Manufacturer Name	SHENZHEN JOINHOLD MULTIMEDIA INDUSTRIAL CO., LTD.
Manufacturer Address	No 160, Pingxin North Road, Pinghu Street, Longgang District, Shenzhen City, Guangdong Province, P.R.China
Product Designation	CDMA Smart phone
Brand Name	WOW
Model Name	WOW 818
Difference Description	N/A.
Applicable Standard	IEEE Std.1528:2003 47CFR§2.1093 IEEE/ANSI C95.1
Test Date	Sep.09, 2013
Test Results	MAX SAR MEASUREMENT(1g) CMDA 800: Head: 0.274 W/Kg Body: 0.712 W/Kg CMDA 1900: Head: 0.476 W/Kg Body: 0.694 W/Kg (Maximum Scaling SAR = 0.714 W/Kg) simultaneous transmission: 0.867 W/Kg
Performed Location	Attestation of Global Compliance(Shenzhen) Co., Ltd.
	2F, Building 2, No.1-No.4,Chaxi Sanwei Technical Industrial Park, Gushu, Xixiang Street, Bao'an District, Shenzhen, China
Report Template	AGCRT-US-2G/SAR (2013-03-01)

Sun YIN

Tested By _____
Sun Yin Sep.18, 2013

Angela Li

Checked By _____
Angela Li Sep.18, 2013

Solger Zhang

Authorized By _____
Solger Zhang Sep.18, 2013

TABLE OF CONTENTS

1. GENERAL INFORMATION	5
1.1. EUT DESCRIPTION.....	5
1.2. TEST PROCEDURE	7
1.3. TEST ENVIRONMENT.....	7
2. SAR MEASUREMENT SYSTEM	8
2.1. COMOSAR SYSTEM DESCRIPTION.....	8
2.2. COMOSAR E-FIELD PROBE	10
2.3. ROBOT.....	10
2.4. VIDEO POSITIONING SYSTEM	11
2.5. DEVICE HOLDER	11
2.6. SAM TWIN PHANTOM.....	12
3. TISSUE SIMULATING LIQUID.....	13
3.1. THE COMPOSITION OF THE TISSUE SIMULATING LIQUID.....	13
3.2. TISSUE CALIBRATION RESULT	14
3.3. TISSUE DIELECTRIC PARAMETERS FOR HEAD AND BODY PHANTOMS.....	15
4. SAR MEASUREMENT PROCEDURE	16
4.1. SAR SYSTEM VALIDATION.....	16
4.2. SAR MEASUREMENT PROCEDURE	18
5. SAR EXPOSURE LIMITS	19
6. TEST EQUIPMENT LIST	20
7. MEASUREMENT UNCERTAINTY	21
8. CONDUCTED POWER MEASUREMENT	22
9. TEST RESULTS	26
9.1. SAR TEST RESULTS SUMMARY	26
APPENDIX A. SAR SYSTEM VALIDATION DATA	37
APPENDIX B. SAR MEASUREMENT DATA.....	43
APPENDIX C. TEST SETUP PHOTOGRAPHS &EUT PHOTOGRAPHS	95
APPENDIX D. PROBE CALIBRATION DATA	108
APPENDIX E. DIPOLE CALIBRATION DATA.....	118

1. General Information

1.1. EUT Description

General Information	
Product Designation	CDMA Smart phone
Test Model	WOW 818
Hardware Version	K818-MB-V0.3
Software Version	N/A
Device Category	Portable
RF Exposure Environment	Uncontrolled
Antenna Type	Internal
CDMA	
Support Band	<input checked="" type="checkbox"/> Band 0 800MHz <input checked="" type="checkbox"/> Band I 1900MHz
TX Frequency Range	CDMA2000 BC0: 824.70 MHz ~ 848.31 MHz CDMA2000 BC1: 1851.25 MHz ~ 1908.75 MHz
RX Frequency Range	CDMA2000 BC0: 869.70 MHz ~ 893.31 MHz CDMA2000 BC1: 1931.25 MHz ~ 1988.75 MHz
Antenna Type:	PIFA Antenna
Type of Modulation:	QPSK
Antenna gain:	1.0dBi
Max. Average Burst Power (Max. Peak Power)	CDMA2000 BC0: 22.35dBm (23.99dBm-Peak power) CDMA2000 BC1: 22.23dBm (23.54dBm-Peak power)
Bluetooth	
Bluetooth Version	<input type="checkbox"/> V2.0 <input type="checkbox"/> V2.1 <input type="checkbox"/> V2.1+EDR <input checked="" type="checkbox"/> V3.0 <input type="checkbox"/> V3.0+EDR <input type="checkbox"/> V4.0
Operation Frequency	2402~2480MHz
Type of modulation	<input checked="" type="checkbox"/> GFSK <input checked="" type="checkbox"/> II/4-DQPSK <input checked="" type="checkbox"/> 8-DPSK
Avg. Burst Power	4.92dBm
Antenna Gain	1.2dBi

WIFI	
WIFI Specification	<input type="checkbox"/> 802.11a <input checked="" type="checkbox"/> 802.11b <input checked="" type="checkbox"/> 802.11g <input checked="" type="checkbox"/> 802.11n(20) <input type="checkbox"/> 802.11n(40)
Operation Frequency	2412~2462MHz
Avg. Burst Power	11b: 13.85dBm; 11g: 11.55dBm; 11n(20): 11.06dBm
Antenna Gain	1.2dBi
Accessories	
Battery	Brand name: WOW Model No. : WOW 818 Voltage and Capacitance: 3.7 V & 2000mAh
Adapter	Brand name: WOW Model No. : WOW 818 Input: AC 100-240V Output: DC 5V, 500mA
Earphone	Brand name: WOW Model No. : WOW 818

Note:

1. The EUT is a model of CDMA Portable Mobile Station (MS). It supports CDMA/EVDO, BT, WIFI and support hot spot mode.
2. The sample used for testing is end product.

1.2. Test Procedure

1	Setup the EUT and simulators as shown on above.
2	Turn on the power of all equipment.
3	EUT communicate with 8960, and test them respectively at EU. bands

1.3. Test Environment

Ambient conditions in the laboratory:

Items	Required	Actual
Temperature (°C)	18-25	21± 2
Humidity (%RH)	30-70	55±2

2. SAR Measurement System

2.1. COMOSAR System Description

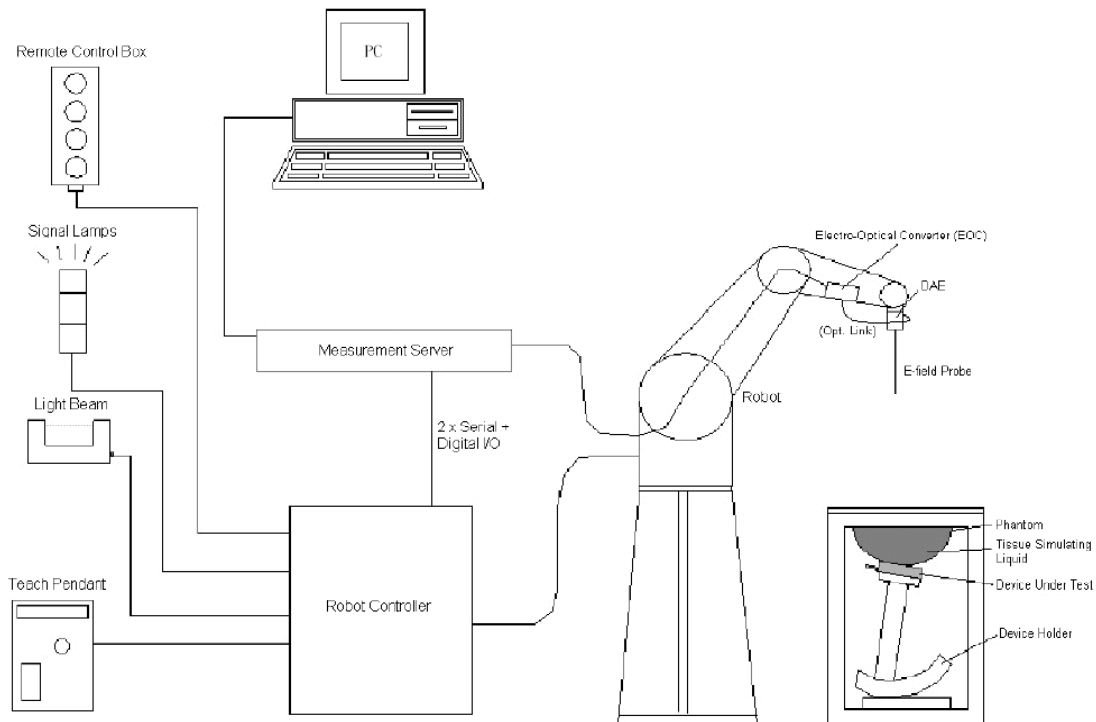

The COMOSAR system for performing compliance tests consists of the following items:

A standard high precision 6-axis robot with controller, teach pendant and software.

An arm extension for accommodating the data acquisition electronics (DAE).

A data acquisition electronics (DAE) which performs the signal amplification, signal multiplexing, AD-conversion, offset measurements, mechanical surface detection, collision detection, etc. The unit is battery powered with standard or rechargeable batteries. The signal is optically transmitted to the EOC.

The Electro-optical converter (EOC) performs the conversion from optical to electrical signals for the digital communication to the DAE. To use optical surface detection, a special version of the EOC is required. The EOC signal is transmitted to the measurement server.

The Light Beam used is for probe alignment. This improves the (absolute) accuracy of the probe positioning.

A computer running WinXP and the Opensar software.

Remote control and teach pendant as well as additional circuitry for robot safety such as warning lamps, etc.

The phantom, the device holder and other accessories according to the targeted measurement.

2.1.1. Applications

Predefined procedures and evaluations for automated compliance testing with all worldwide standards, e.g., IEEE 1528, OET 65, IEC 62209-1, IEC 62209-2, EN 50360, EN 50383 and others.

2.1.2. Area Scans

Area scans are defined prior to the measurement process being executed with a user defined variable spacing between each measurement point (integral) allowing low uncertainty measurements to be conducted. Scans defined for FCC applications utilize a 10mm² step integral, with 1mm interpolation used to locate the peak SAR area used for zoom scan assessments.

When an Area Scan has measured all reachable points, it computes the field maxima found in the scanned area, within a range of the global maximum. The range (in dB) is specified in the standards for compliance testing. For example, a 2 dB range is required in IEEE 1528-2003, EN 50361 and IEC 62209 standards, whereby 3 dB is a requirement when compliance is assessed in accordance with the ARIB standard (Japan).

2.1.3. Zoom Scan (Cube Scan Averaging)

Zoom Scans are used to assess the peak spatial SAR values within a cubic averaging volume containing 1 g and 10 g of simulated tissue. A density of 1000 kg/m³ is used to represent the head and body tissue density and not the phantom liquid density, in order to be consistent with the definition of the liquid dielectric properties, i.e. the side length of the 1 g cube is 10mm, with the side length of the 10 g cube 21,5mm.

The zoom scan integer steps can be user defined so as to reduce uncertainty, but normal practice for typical test applications utilize a physical step of 7x7x7 (5mmx5mmx5mm) providing a volume of 30mm in the X & Y axis, and 30mm in the Z axis.

2.1.4. Uncertainty of Inter-/Extrapolation and Averaging

In order to evaluate the uncertainty of the interpolation, extrapolation and averaged SAR calculation algorithms of the Post processor, COMOSAR allows the generation of measurement grids which are artificially predefined by analytically based test functions. Therefore, the grids of area scans and zoom scans can be filled with uncertainty test data, according to the SAR benchmark functions of IEEE 1528. The three analytical functions shown in equations as below are used to describe the possible range of the expected SAR distributions for the tested handsets. The field gradients are covered by the spatially flat distribution f1, the spatially steep distribution f3 and f2 accounts for H-field cancellation on the phantom/tissue surface.

$$f_1(x, y, z) = A e^{-\frac{z}{2a}} \cos^2 \left(\frac{\pi \sqrt{x'^2 + y'^2}}{2 \cdot 5a} \right)$$

$$f_2(x, y, z) = A e^{-\frac{z}{a}} \frac{a^2}{a^2 + x'^2} \left(3 - e^{-\frac{2z}{a}} \right) \cos^2 \left(\frac{\pi y'}{2 \cdot 3a} \right)$$

$$f_3(x, y, z) = A \frac{a^2}{\frac{a^2}{4} + x'^2 + y'^2} \left(e^{-\frac{2z}{a}} + \frac{a^2}{2(a + 2z)^2} \right)$$

2.2. COMOSAR E-Field Probe

The SAR measurement is conducted with the dissymmetric probe manufactured by SATIMO.

The probe is specially designed and calibrated for use in liquid with high permittivity. The dissymmetric probe has special calibration in liquid at different frequency.

SATIMO conducts the probe calibration in compliance with international and national standards (e.g. IEEE 1528, EN62209-1, IEC 62209, etc.) Under ISO17025. The calibration data are in Appendix D.

2.2.1. Isotropic E-Field Probe Specification

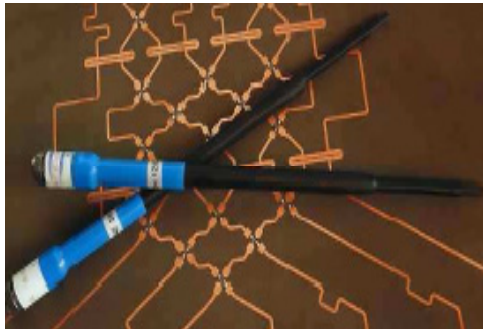
Model	EP165	
Manufacture	SATIMO	
frequency	0.03GHz-3 GHz Linearity:±0.2dB(30 MHz-3 GHz)	
Dynamic Range	0.01W/Kg-100W/Kg Linearity:±0.2dB	
Dimensions	Overall length:330mm Length of individual dipoles:4.5mm Maximum external diameter:8mm Probe Tip external diameter:5mm Distance between dipoles/ probe extremity:2.7mm	
Application	High precision measurements in any exposure scenario (e.g., very strong gradient fields). Only probe which enables compliance testing for frequencies up to 6 GHz with precision of better 30%.	

2.3. Robot

The COMOSAR system uses the KUKA robots from SATIMO SA (France).For the 6-axis controller COMOSAR system, the KUKA robot controller version from SATIMO is used.

The XL robot series have many features that are important for our application:

- High precision (repeatability 0.02 mm)
- High reliability (industrial design)
- Jerk-free straight movements
- Low ELF interference (the closed metallic construction shields against motor control fields)
- 6-axis controller



2.4. Video Positioning System

The video positioning system is used in OpenSAR to check the probe. Which is composed of a camera, LED, mirror and mechanical parts. The camera is piloted by the main computer with firewire link.

During the process, the actual position of the probe tip with respect to the robot arm is measured, as well as the probe length and the horizontal probe offset. The software then corrects all movements, such that the robot coordinates are valid for the probe tip.

The repeatability of this process is better than 0.1 mm. If a position has been taught with an aligned probe, the same position will be reached with another aligned probe within 0.1 mm, even if the other probe has different dimensions. During probe rotations, the probe tip will keep its actual position.

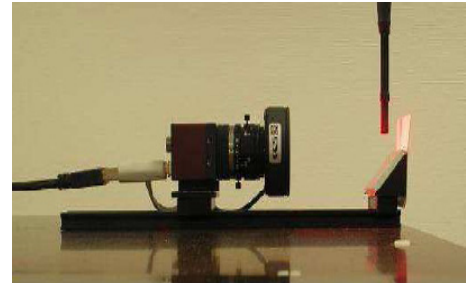

2.5. Device Holder

The COMOSAR device holder is designed to cope with different positions given in the standard. It has two scales for the device rotation (with respect to the body axis) and the device inclination (with respect to the line between the ear reference points). The rotation center for both scales is the ear reference point (EPR).

Thus the device needs no repositioning when changing the angles.

The COMOSAR device holder has been made out of low-loss POM material having the following dielectric parameters: relative permittivity $\epsilon_r = 3$ and loss tangent $\delta = 0.02$. The amount of dielectric material has been reduced in the closest vicinity of the device, since measurements have suggested that the influence of the clamp on the test results could thus be lowered.

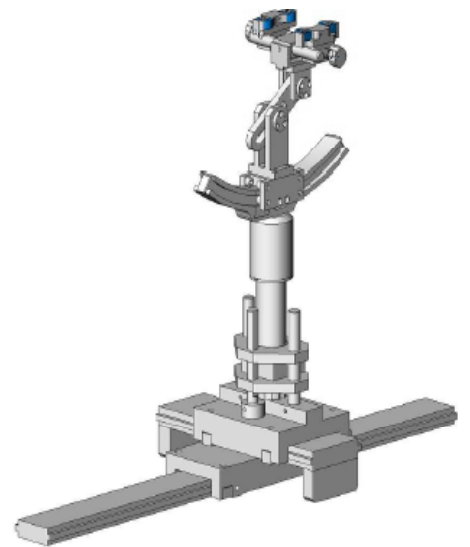

2.6. SAM Twin Phantom

The SAM twin phantom is a fiberglass shell phantom with 2mm shell thickness (except the ear region where shell thickness increases to 6mm). It has three measurement areas:

- Left head
- Right head
- Flat phantom

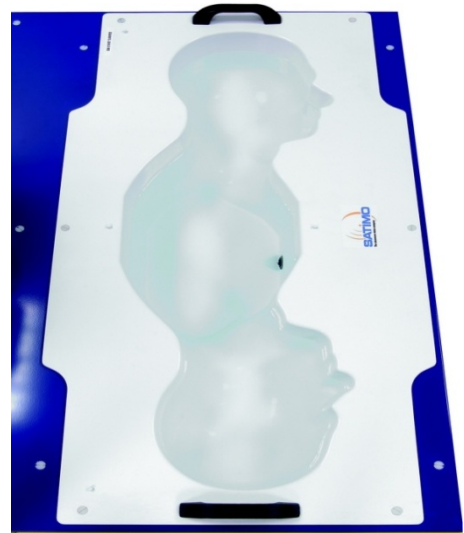

The bottom plate contains three pair of bolts for locking the device holder. The device holder positions are adjusted to the standard measurement positions in the three sections. A white cover is provided to tap the phantom during off-periods to prevent water evaporation and changes in the liquid parameters. On the phantom top, three reference markers are provided to identify the phantom position with respect to the robot.

3.2. Tissue Calibration Result

The dielectric parameters of the liquids were verified prior to the SAR evaluation using COMOSAR Dielectric Probe Kit and R&S Network Analyzer ZVL6 .

Tissue Stimulant Measurement for 835MHz					
Frequency (MHz)	Parts	Description	Dielectric Parameters		Tissue Temp [°C]
835MHz	Head	Reference result ±5% window	ϵ_r 41.50 39.43-43.58	δ [s/m] 0.97 0.92-1.02	N/A
		Sep.09, 2013	40.23	0.88	21
	Body	Reference result ±5% window	ϵ_r 55.0 52.25-57.75	δ [s/m] 1.05 0.9975-1.1025	N/A
		Sep.09, 2013	53.62	0.96	21

Tissue Stimulant Measurement for 1900MHz					
Frequency (MHz)	Parts	Description	Dielectric Parameters		Tissue Temp [°C]
1900MHz	Head	Reference result ±5% window	ϵ_r 40.00 38.00-42.00	δ [s/m] 1.40 1.33-1.47	N/A
		Sep.09, 2013	39.87	1.38	21
	Body	Reference result ±5% window	ϵ_r 53.30 50.635-55.965	δ [s/m] 1.52 1.444-1.596	N/A
		Sep.09, 2013	54.01	1.49	21

Tissue Stimulant Measurement for 2450MHz					
Frequency (MHz)	Parts	Description	Dielectric Parameters		Tissue Temp [°C]
2450MHz	Head	Reference result ±5% window	ϵ_r 39.2 37.24-41.16	δ [s/m] 1.80 1.71-1.89	N/A
		Sep.09, 2013	40.63	1.77	21
	Body	Reference result ±5% window	ϵ_r 52.7 50.065-55.335	δ [s/m] 1.95 1.8525-2.0475	N/A
		Sep.09, 2013	53.16	1.92	21

3.3. Tissue Dielectric Parameters for Head and Body Phantoms

The head tissue dielectric parameters recommended by the IEEE SCC-34/SC-2 in P1528 have been incorporated in the following table. These head parameters are derived from planar layer models simulating the highest expected SAR for the dielectric properties and tissue thickness variations in a human head. Other head and body tissue parameters that have not been specified in P1528 are derived from the tissue dielectric parameters computed from the 4-Cole-Cole equations described in Reference [12] and extrapolated according to the head parameters specified in P1528.

Target Frequency (MHz)	head		body	
	ϵ_r	σ (S/m)	ϵ_r	σ (S/m)
300	45.3	0.87	58.2	0.92
450	43.5	0.87	56.7	0.94
835	41.5	0.90	55.2	0.97
900	41.5	0.97	55.0	1.05
915	41.5	0.98	55.0	1.06
1450	40.5	1.20	54.0	1.30
1610	40.3	1.29	53.8	1.40
1800 – 2000	40.0	1.40	53.3	1.52
2450	39.2	1.80	52.7	1.95
3000	38.5	2.40	51.6	2.73
5800	35.3	5.27	48.2	6.00

(ϵ_r = relative permittivity, σ = conductivity and $\rho = 1000$ kg/m³)

4. SAR Measurement Procedure

4.1. SAR System Validation

4.1.1. Validation Dipoles

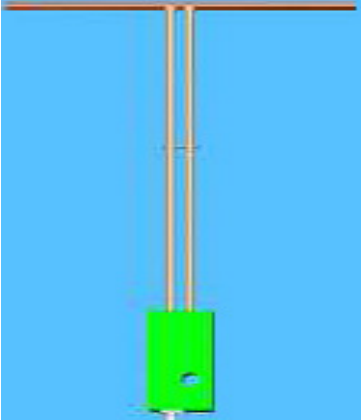
	<p>The dipoles used is based on the IEEE-1528 standard, and is complied with mechanical and electrical specifications in line with the requirements of both IEEE and FCC Supplement C. the table below provides details for the mechanical and electrical Specifications for the dipoles.</p>
---	---

Frequency	L (mm)	h (mm)	d (mm)
900 MHz	149.0	83.3	3.6
1900MHz	68	39.5	3.6
2450MHz	51.5	30.4	3.6

4.1.2. Validation Result

System Performance Check at 835 MHz &1900MHz & 2450 MHz for Head				
Validation Kit: SN 46/11DIP 0G900-185				
Frequency [MHz]	Description	SAR [w/kg] 1g	SAR [w/kg] 10g	Tissue Temp.[°C]
900 MHz	Reference result ± 10% window	10.9 9.81 to 11.99	6.99 6.29 to 7.69	N/A
	Sep.09, 2013	11.78	6.94	21
Validation Kit: SN 46/11DIP 1G900-187				
Frequency [MHz]	Description	SAR [w/kg] 1g	SAR [w/kg] 10g	Tissue Temp.[°C]
1900 MHz	Reference result ± 10% window	39.7 35.73 to 43.67	20.5 18.45 to 22.55	N/A
	Sep.09, 2013	41.16	21.36	21.0
Validation Kit: SN 46/11DIP 2G450-189				
Frequency [MHz]	Description	SAR [w/kg] 1g	SAR [w/kg] 10g	Tissue Temp.[°C]
2450 MHz	Reference result ± 10% window	52.4 47.16 to 57.64	24.0 21.6 to 26.4	N/A
	Sep.09, 2013	49.35	25.43	21
Note: All SAR values are normalized to 1W forward power.				

4.2. SAR Measurement Procedure

The COMOSAR calculates SAR using the following equation,

$$SAR = \frac{\sigma |E|^2}{\rho}$$

σ : represents the simulated tissue conductivity

ρ : represents the tissue density

The EUT is set to transmit at the required power in line with product specification, at each frequency relating to the LOW, MID, and HIGH channel settings.

Pre-scans are made on the device to establish the location for the transmitting antenna, using a large area scan in either air or tissue simulation fluid.

The EUT is placed against the Universal Phantom where the maximum area scan dimensions are larger than the physical size of the resonating antenna. When the scan size is not large enough to cover the peak SAR distribution, it is modified by either extending the area scan size in both the X and Y directions, or the device is shifted within the predefined area.

The area scan is then run to establish the peak SAR location (interpolated resolution set at 1mm²) which is then used to orient the center of the zoom scan. The zoom scan is then executed and the 1g and 1g averages are derived from the zoom scan volume (interpolated resolution set at 1mm³).

When multiple peak SAR locations were found during the same configuration or test mode, Zoom scan shall performed on each peak SAR location, only the peak point with maximum SAR value will be reported for the configuration or test mode.

5. SAR Exposure Limits

SAR assessments have been made in line with the requirements of IEEE-1528, FCC Supplement C, and comply with ANSI/IEEE C95.1-1992 “Uncontrolled Environments” limits. These limits apply to a location which is deemed as “Uncontrolled Environment” which can be described as a situation where the general public may be exposed to an RF source with no prior knowledge or control over their exposure.

Limits for General Population/Uncontrolled Exposure (W/kg)

Type Exposure	Uncontrolled Environment Limit
Spatial Peak SAR (1g cube tissue for brain or body)	1.60 W/kg

6. Test Equipment List

Equipment description	Manufacturer/Model	Identification No.	Current calibration date	Next calibration date
SAR Probe	SATIMO	SN 04/13 EP165	01/31/2013	01/30/2014
Phantom	SATIMO	SN_4511_SAM90	Validated. No cal required.	Validated. No cal required.
Liquid	SATIMO	-	Validated. No cal required.	Validated. No cal required.
Comm Tester	R&S - CMU200	069Y7-158-13-712	02/28/2013	02/27/2014
Comm Tester	Agilent-8960	GB46310822	10/22/2012	10/21/2013
Multimeter	Keithley 2000	1188656	02/28/2013	02/27/2014
Dipole	SATIMO SID900	SN46/11 DIP 0G900-185	12/09/2011	12/08/2013
Dipole	SATIMO SID1900	SN46/11 DIP 1G900-187	12/09/2011	12/08/2013
Dipole	SATIMO SID2450	SN46/11 DIP 2G450-189	12/09/2011	12/08/2013
Amplifier	Aethercomm	SN 046	12/08/2012	12/07/2013
Signal Generator	Agilent-E4421B	MY43351603	05/13/2013	05/12/2014
Power Probe	NRP-Z23	US38261498	02/28/2013	02/27/2014
SPECTRUM ANALYZER	Agilent/E4440A	MY44303916	10/22/2012	10/21/2013
Power Attenuator	BED	DLA-5W	07/30/2013	07/29/2014
Network Analyzer	Rhode & Schwarz ZVA	SN100132	02/28/2013	02/27/2014

Note: Per KDB 50824 Dipole SAR Validation Verification, AGC Lab has adopted 3 years calibration intervals. On annual basis, every measurement dipole has been evaluated and is in compliance with the following criteria:

1. There is no physical damage on the dipole;
2. System validation with specific dipole is within 10% of calibrated value;
3. Return-loss is within 20% of calibrated measurement;
4. Impedance is within 5Ω of calibrated measurement.

7. Measurement Uncertainty

SATIMO Uncertainty									
Measurement uncertainty for 30 MHz to 3 GHz averaged over 1 gram / 10 gram.									
Error Description	Sec	Tol (±%)	Prob. Dist.	Div.	(Ci) 1g	(Ci) 1g	Std. Unc. (1g) (±%)	Std. Unc. (1g)(±%)	(Vi) Veff
Measurement System									
Probe Calibration	E.2.1	6	N	1	1	1	6	6	∞
Axial Isotropy	E.2.2	3	R	$\sqrt{3}$	$(1-C_p)^{1/2}$	$(1-C_p)^{1/2}$	1.22474	1.22474	∞
Hemispherical Isotropy	E.2.2	5	R	$\sqrt{3}$	$\sqrt{C_p}$	$\sqrt{C_p}$	1.64124	1.64124	∞
Boundary Effects	E.2.3	1	R	$\sqrt{3}$	1	1	0.57735	0.57735	∞
Linearity	E.2.4	5	R	$\sqrt{3}$	1	1	2.88675	2.88675	∞
System Detection Limits	E.2.5	1	R	$\sqrt{3}$	1	1	0.57735	0.57735	∞
Readout Electronics	E.2.6	0.5	N	1	1	1	0.5	0.5	∞
Response Time	E.2.7	0.2	R	$\sqrt{3}$	1	1	0.11547	0.11547	∞
Integration Time	E.2.8	2	R	$\sqrt{3}$	1	1	1.1547	1.1547	∞
RF Ambient Noise	E.6.1	3	R	$\sqrt{3}$	1	1	1.73205	1.73205	∞
Probe Positioner Mechanical Tolerance	E.6.2	2	R	$\sqrt{3}$	1	1	1.1547	1.1547	∞
Probe Positioning with Respect to Phantom Shell	E.6.3	1	R	$\sqrt{3}$	1	1	0.57735	0.57735	∞
Extrapolation,interpolation and Integration Algorithms for Max. SAR Evaluation	E.5.2	1.5	R	$\sqrt{3}$	1	1	0.86603	0.86603	∞
Dipole									
Device Positioning	8,E.4.2	1	N	$\sqrt{3}$	1	1	0.57735	0.57735	N-1
Power Drift	8.6.6.2	2	R	$\sqrt{3}$	1	1	1.1547	1.1547	∞
Phantom and Tissue Parameters									
Phantom Uncertainty	E.3.1	4	R	$\sqrt{3}$	1	1	2.3094	2.3094	∞
Liquid Conductivity (target)	E.3.2	5	R	$\sqrt{3}$	0.64	0.43	1.84752	1.2413	∞
Liquid Conductivity (meas.)	E.3.3	2.5	N	1	0.64	0.43	1.6	0.875	∞
Liquid Permittivity (target)	E.3.2	3	R	$\sqrt{3}$	0.6	0.49	0.83923	0.8487	∞
Liquid Permittivity (meas.)	E.3.3	2.5	N	1	0.6	0.49	1.5	1.225	M
Combined Standard Uncertainty			RSS				8.09272	7.9296	
Expanded Uncertainty (95%CONFIDENCE INTERVAL)			k				16.18544	15.8594	

8. Conducted Power Measurement
CDMA 2000 BC0/ CDMA2000 1xEV-DO

Mode	Channel	Frequency (MHz)	Avg.Burst Power
1xRTT RC1 SO55	1013	824.7	22.12
	384	836.52	22.30
	777	848.31	22.23
1xRTT RC3 SO55	1013	824.7	22.24
	384	836.52	22.28
	777	848.31	22.26
1xRTT RC3 SO32 (+ F-SCH)	1013	824.7	22.04
	384	836.52	22.35
	777	848.31	22.23
1xRTT RC3 SO32(+SCH)	1013	824.7	22.17
	384	836.52	22.21
	777	848.31	22.17
1xEV-DO RTAP 153.6K	1013	824.7	22.13
	384	836.52	22.17
	777	848.31	22.22
1xEV-DO RETAP 4096K	1013	824.7	22.09
	384	836.52	22.19
	777	848.31	22.06

CDMA 2000 BC1/ CDMA2000 1xEV-DO

Mode	Channel	Frequency (MHz)	Avg.Burst Power
1xRTT RC1 SO55	25	1851.25	22.13
	600	1880	22.16
	1175	1908.75	22.16
1xRTT RC3 SO55	25	1851.25	22.17
	600	1880	22.18
	1175	1908.75	22.16
1xRTT RC3 SO32 (+ F-SCH)	25	1851.25	22.09
	600	1880	22.12
	1175	1908.75	22.23
1xRTT RC3 SO32(+SCH)	25	1851.25	22.15
	600	1880	22.19
	1175	1908.75	22.21
1xEV-DO RTAP 153.6K	25	1851.25	22.18
	600	1880	22.14
	1175	1908.75	22.15
1xEV-DO RETAP 4096K	25	1851.25	22.13
	600	1880	22.11
	1175	1908.75	22.15

WIFI

Mode	Data Rate (Mbps)	Channel	Frequency(MHz)	Avg. Burst Power(dBm)
802.11b	1	01	2412	13.54
		06	2437	13.75
		11	2462	13.85
802.11g	6	01	2412	11.25
		06	2437	11.41
		11	2462	11.55
802.11n(20)	6.5	01	2412	10.86
		06	2437	10.97
		11	2462	11.06

According to 3GPP 25.101 sub-clause 6.2.2 , the maximum output power is allowed to be reduced by following the table.

Table 6.1aA: UE maximum output power with HS-DPCCH and E-DCH

UE Transmit Channel Configuration	CM(db)	MPR(db)
For all combinations of ,DPDCH,DPCCH HS-DPDCH,E-DPDCH and E-DPCCH	$0 \leq CM \leq 3.5$	$MAX(CM-1,0)$
Note: CM=1 for $\beta_d/\beta_d=12/15$, $\beta_{ns}/\beta_c=24/15$.For all other combinations of DPDCH, DPCCH, HS-DPCCH, E-DPDCH and E-DPCCH the MPR is based on the relative CM difference.		

The device supports MPR to solve linearity issues (ACLR or SEM) due to the higher peak-to average ratios (PAR) of the HSUPA signal. This prevents saturating the full range of the TX DAC inside of device and provides a reduced power output to the RF transceiver chip according to the Cubic Metric (a function of the combinations of DPDCH, DPCCH, HS-DPCCH, E-DPDCH and E-DPCCH).

When E-DPDCH channels are present the beta gains on those channels are reduced firsts to try to get the power under the allowed limit. If the beta gains are lowered as far as possible, then a hard limiting is applied at the maximum allowed level.

The SW currently recalculates the cubic metric every time the beta gains on the E-DPDCH are reduced. The cubic metric will likely get lower each time this is done .However, there is no reported reduction of maximum output power in the HSUPA mode since the device also provides a compensation for the power back-off by increasing the gain of TX_AGC in the transceiver (PA) device.

The end effect is that the DUT output power is identical to the case where there is no MPR in the device.

9. Test Results

9.1. SAR Test Results Summary

9.1.1. Test position and configuration

Head SAR was performed with the device configured in the positions according to IEEE1528, and Body SAR was performed with the device 5mm from the phantom; the overall device length and width(14.7cm×7.8cm) are >9cm×5cm, Hotspot mode with a test separation distance of 10mm.

9.1.2. Operation Mode

- According to KDB 447498 D01 v05r01 ,for each exposure position, if the highest 1-g SAR is ≤ 0.8 W/kg, testing for low and high channel is optional.
- Per KDB 865664 D01 v01r01,for each frequency band, if the measured SAR is ≥ 0.8 W/Kg, testing for repeated SAR measurement is required , that the highest measured SAR is only to be tested. When the SAR results are near the limit, the following procedures are required for each device to verify these types of SAR measurement related variation concerns by repeating the highest measured SAR configuration in each frequency band.
 - (1) When the original highest measured SAR is ≥ 0.8 W/Kg, repeat that measurement once.
 - (2) Perform a second repeated measurement only if the ratio of largest to smallest SAR for the original and first repeated measurements is > 1.20 or when the original or repeated measurement is ≥ 1.45 W/Kg.
 - (3) Perform a third repeated measurement only if the original, first and second repeated measurement is ≥ 1.5 W/Kg and ratio of largest to smallest SAR for the original, first and second measurement is ≥ 1.20 .
- Body-worn exposure conditions are intended to voice call operations, therefore GSM voice call mode is selected to be test.
- According to KDB 648474 D04 v01r01,when the reported SAR for a body-worn accessory measured without a headset connected to the handset is ≤ 1.2 W/Kg, SAR testing with a headset connected is not required.
- According to 941225 D06, when the overall device length and width are >9cm×5cm, Hotspot mode with a test separation distance of 10mm. For device with form factors smaller than 9cm×5cm, Hotspot mode with a test separation distance of 5mm. Body SAR was also performed with the headset attached and without.
- According to 248227 D01, SAR is not required for 802.11g channels when the maximum average output power is less than 1/4dB higher than measured on the corresponding 802.11b channels.
- Maximum Scaling SAR in order to calculate the Maximum SAR values to test under the standard Peak Power, Calculation method is as follows:
Maximum Scaling SAR =tested SAR (Max.) \times (GSM standard Peak Power (mw)/ tested Max. Peak Power (mw))

9.1.3. SAR Test Results Summary

SAR MEASUREMENT								
Ambient Temperature (°C) : 21 ± 2						Relative Humidity (%): 55		
Liquid Temperature (°C) : 21 ± 2						Depth of Liquid (cm):>15		
Product: CDMA Smart phone								
Test Mode: CDMA 800								
Configuration			Antenna Position	Frequency		Power Drift (<±5%)	SAR (1g) (W/kg)	Limit (W/kg)
SIM	Position	Status		channel	MHz			
<1>	Left Head	Cheek	Fixed	1013	824.7	--	--	--
				384	836.52	0.18	0.257	1.6
				777	848.31	--	--	--
		Tilted	Fixed	1013	824.7	--	--	--
				384	836.52	0.63	0.207	1.6
				777	848.31	--	--	--
	Right Head	Cheek	Fixed	1013	824.7	--	--	--
				384	836.52	0.74	0.274	1.6
				777	848.31	--	--	--
		Tilted	Fixed	1013	824.7	--	--	--
				384	836.52	-1.42	0.213	1.6
				777	848.31	--	--	--
<2>	Right	Cheek	Fixed	384	836.52	0.15	0.261	1.6

Note: when the 1-g SAR is ≤ 0.8W/kg, testing for low and high channel is optional.

SAR MEASUREMENT								
Ambient Temperature (°C) : 21 ± 2						Relative Humidity (%): 55		
Liquid Temperature (°C) : 21 ± 2						Depth of Liquid (cm):>15		
Product: CDMA Smart phone								
Test Mode: : CDMA 800								
Configuration			Antenna Position	Frequency		Power Drift (<±5%)	SAR (1g) (W/kg)	Limit (W/kg)
SIM	Position	Status		channel	MHz			
<1>	Body Back	MS	Fixed	1013	824.7	--	--	--
				384	836.52	0.18	0.712	1.6
				777	848.31	--	--	--
	Body Front	MS	Fixed	1013	824.7	--	--	--
				384	836.52	0.24	0.325	1.6
				777	848.31	--	--	--

Note: when the 1-g SAR is ≤ 0.8W/kg, testing for low and high channel is optional.

SAR MEASUREMENT								
Ambient Temperature (°C) : 21 ± 2						Relative Humidity (%): 55		
Liquid Temperature (°C) : 21 ± 2						Depth of Liquid (cm):>15		
Product: CDMA Smart phone								
Test Mode: CDMA 1900								
Configuration			Antenna Position	Frequency		Power Drift (<±5%)	SAR (1g) (W/kg)	Limit (W/kg)
SIM	Position	Status		channel	MHz			
<1>	Left Head	Cheek	Fixed	25	1851.25	--	--	--
				600	1880	0.08	0.476	1.6
				1175	1908.75	--	--	--
		Tilted	Fixed	25	1851.25	--	--	--
				600	1880	1.24	0.184	1.6
				1175	1908.75	--	--	--
	Right Head	Cheek	Fixed	25	1851.25	--	--	--
				600	1880	0.63	0.365	1.6
				1175	1908.75	--	--	--
		Tilted	Fixed	25	1851.25	--	--	--
				600	1880	1.47	0.354	1.6
				1175	1908.75	--	--	--
<2>	Left	Cheek	Fixed	600	1880	0.23	0.447	1.6

Note: when the 1-g SAR is ≤ 0.8W/kg, testing for low and high channel is optional.

SAR MEASUREMENT								
Ambient Temperature (°C) : 21 ± 2						Relative Humidity (%): 55		
Liquid Temperature (°C) : 21 ± 2						Depth of Liquid (cm):>15		
Product: CDMA Smart phone								
Test Mode: : CDMA 1900								
Configuration			Antenna Position	Frequency		Power Drift (<±5%)	SAR (1g) (W/kg)	Limit (W/kg)
SIM	Position	Status		channel	MHz			
<1>	Body Back	MS	Fixed	25	1851.25	--	--	--
				600	1880	0.14	0.694	1.6
				1175	1908.75	--	--	--
	Body Front	MS	Fixed	25	1851.25	--	--	--
				600	1880	1.12	0.233	1.6
				1175	1908.75	--	--	--

Note: when the 1-g SAR is ≤ 0.8W/kg, testing for low and high channel is optional.

SAR MEASUREMENT								
Ambient Temperature (°C) : 21 ± 2						Relative Humidity (%): 55		
Liquid Temperature (°C) : 21 ± 2						Depth of Liquid (cm):>15		
Product: CDMA Smart phone								
Test Mode: 802.11b								
Configuration			Antenna Position	Frequency		Power Drift (<±5%)	SAR (1g) (W/kg)	Limit (W/kg)
Test Mode	Position	Status		channel	MHz			
802.11b	Left Head	Cheek	Fixed	1	2412	--	--	--
				6	2437	1.24	0.174	1.6
				11	2462	--	--	--
		Tilted	Fixed	1	2412	--	--	--
				6	2437	1.28	0.146	1.6
				11	2462	--	--	--
	Right Head	Cheek	Fixed	1	2412	--	--	--
				6	2437	-0.63	0.168	1.6
				11	2462	--	--	--
		Tilted	Fixed	1	2412	--	--	--
				6	2437	0.45	0.133	1.6
				11	2462	--	--	--

Note1: when the 1-g SAR is ≤ 0.8 W/kg, testing for low and high channel is optional.
Note2: IEEE802.11b support DBPSK, DQPSK, CCK modulation mode, IEEE802.11g/n support OFDM, 16-QAM, 64-QAM modulation mode.

SAR MEASUREMENT								
Ambient Temperature (°C) : 21 ± 2						Relative Humidity (%): 55		
Liquid Temperature (°C) : 21 ± 2						Depth of Liquid (cm):>15		
Product: CDMA Smart phone								
Test Mode: 802.11b								
Configuration			Antenna Position	Frequency		Power Drift (<±5%)	SAR (1g) (W/kg)	Limit (W/kg)
Test Mode	Position	Status		channel	MHz			
802.11b	Body Back	MS	Fixed	1	2412	--	--	--
				6	2437	0.14	0.155	1.6
				11	2462	--	--	--
	Body front	MS	Fixed	1	2412	--	--	--
				6	2437	-0.18	0.063	1.6
				11	2462	--	--	--

Note1: when the 1-g SAR is ≤ 0.8 W/kg, testing for low and high channel is optional.
Note2: IEEE802.11b support DBPSK, DQPSK, CCK modulation mode, IEEE802.11g/n support OFDM, 16-QAM, 64-QAM modulation mode.

SAR MEASUREMENT								
Ambient Temperature (°C) : 21 ± 2						Relative Humidity (%): 55		
Liquid Temperature (°C) : 21 ± 2						Depth of Liquid (cm):>15		
Product: CDMA Smart phone								
Test Mode: Hotspot								
Configuration			Antenna Position	Frequency		Power Drift (<±5%)	SAR (1g) (W/kg)	Limit (W/kg)
Test Mode	Position	Status		channel	MHz			
Hotspot	Left Head	Cheek	Fixed	1	2412	--	--	--
				6	2437	-0.17	0.104	1.6
				11	2462	--	--	--
		Tilted	Fixed	1	2412	--	--	--
				6	2437	0.45	0.104	1.6
				11	2462	--	--	--
	Right Head	Cheek	Fixed	1	2412	--	--	--
				6	2437	-0.57	0.164	1.6
				11	2462	--	--	--
		Tilted	Fixed	1	2412	--	--	--
				6	2437	0.52	0.145	1.6
				11	2462	--	--	--

Note: when the 1-g SAR is ≤ 0.8 W/kg, testing for low and high channel is optional.

SAR MEASUREMENT								
Ambient Temperature (°C) : 21 ± 2						Relative Humidity (%): 55		
Liquid Temperature (°C) : 21 ± 2						Depth of Liquid (cm):>15		
Product: CDMA Smart phone								
Test Mode: Hotspot								
Configuration			Antenna Position	Frequency		Power Drift (<±5%)	SAR (1g) (W/kg)	Limit (W/kg)
Test Mode	Position	Status		channel	MHz			
Hotspot	Body Back	MS	Fixed	1	2412	--	--	--
				6	2437	0.17	0.137	1.6
				11	2462	--	--	--
	Body front	MS	Fixed	1	2412	--	--	--
				6	2437	1.36	0.124	1.6
				11	2462	--	--	--

Note: when the 1-g SAR is ≤ 0.8 W/kg, testing for low and high channel is optional.

**Simultaneous Multi-band Transmission Evaluation:
Application Simultaneous Transmission information:**

Position	Simultaneous state
Head	1.WWAN(voice)+WLAN 2.4GHz band
	2.WWAN(voice)+Bluetooth
	3.WWAN(voice)+ HOTSPOT 2.4GHz band
Body	4. WWAN(voice)+WLAN 2.4GHz band
	5. WWAN(voice)+Bluetooth
	6.WWAN(voice)+ HOTSPOT 2.4GHz band

NOTE:

1. WLAN and BT share the same antenna, and cannot transmit simultaneously.
2. Simultaneous with every transmitter must be the same test position.
3. Based upon KDB 447498 D01 v05, BT SAR is excluded as below table.
4. Based upon KDB 447498 D01 v05,for handsets the test separation distance is determined by the smallest distance between the outer surface of the device and the user; which is 0mm for head SAR AND 5mm for body-worn SAR.
5. If the test separation distance is <5mm, 5mm is used for excluded SAR calculation.
6. For minimum test separation distance ≤ 50 mm,Bluetooth standalone SAR is excluded according to $[(\text{max. power of channel, including tune-up tolerance, mW}) / (\text{min. test separation distance, mm}) \cdot \sqrt{f \text{ (GHz)}} / x] \leq 3.0$ for 1-g SAR and ≤ 7.5 for 10-g extremity SAR
7. KDB 447498 / 4.3.2 (2) when standalone SAR test exclusion applies to an antenna that transmits simultaneously with other antennas, the standalone SAR must be estimated according to following to determine simultaneous transmission SAR test exclusion:
 - a) $(\text{max. power of channel, including tune-up tolerance, mW}) / (\text{min. test separation distance, mm}) \cdot \sqrt{f \text{ (GHz)}} / x$ W/kg for test separation distances ≤ 50 mm; Where $x = 7.5$ for 1-g SAR, and $x = 18.75$ for 10-g SAR.
 - b) 0.4W/Kg for 1-g SAR and 1.0W/Kg for 10-g SAR, when the separation distance is >50mm.

		Maximum Average Power		Antenna to user (mm)	SAR exclusion threshold (mW)	SAR testing required (Yes/No)	Head (0mm gap)	Body (5mm gap)
		dBm	mW					
BT	Head	4.92	3.105	5	10	NO	0.1294 W/kg	0.1294 W/kg
	Body			5	10	NO		

Maximum test results (WWAN) with BT and WIFI/ HOTSPOT Simultaneous Transmission SAR:

BT: Head (0 cm gap): 0.1294 W/kg and Body (0.5 cm gap): 0.1294 W/kg

Head (WWAN (voice) +BT): 0.476 W/kg +0.1294 W/kg = 0.6054 W/kg

Body (WWAN (voice) +BT): 0.694 W/kg +0.1294 W/kg = 0.8234 W/kg

WIFI

Head					
Conditions (SAR1+SAR2)	Position	Max. SAR1	Max. SAR2	SAR Summation	Limit (W/kg)
CDMA800 +WIFI (voice)	Left Cheek	0.257	0.174	0.431	1.6
CDMA800 +WIFI (voice)	Right Cheek	0.274	0.168	0.442	
CDMA1900 +WIFI (voice)	Left Cheek	0.476	0.174	0.650	1.6
Body					
Conditions (SAR1+SAR2)	Position	Max. SAR1	Max. SAR2	SAR Summation	Limit (W/kg)
CDMA800 +WIFI (voice)	Body Back (MS)	0.712	0.155	0.867	1.6
CDMA1900 +WIFI (voice)	Body Back (MS)	0.694	0.155	0.849	1.6

Appendix A. SAR System Validation Data

Test Laboratory: AGC Lab
 System Check Head 835 MHz

Date: Sep.09, 2013

DUT: Dipole 900 MHz Type: SID 900

Communication System: CW; Communication System Band: D835 (900.0 MHz); Duty Cycle: 1:1; Conv.F=5.30
 Frequency: 835 MHz; Medium parameters used: $f = 835$ MHz; $\sigma=0.88$ mho/m; $\epsilon_r =40.23$; $\rho= 1000$ kg/m³ ;
 Phantom section: Flat Section; Input Power=10dBm
 Ambient temperature (°C): 21, Liquid temperature (°C): 21

SATIMO Configuration:

- Probe: EP165; Calibrated: 01/31/2013
- Sensor-Surface: 4mm (Mechanical Surface Detection)
- Phantom: Flat Phantom; Type: Elliptical Phantom
- Measurement SW: OpenSAR V4_02_01

Configuration/System Check GSM835 Head/Area Scan: Measurement grid: dx=8mm, dy=8mm
Configuration/System Check GSM835 Head/Zoom Scan: Measurement grid: dx=8mm, dy=8mm, dz=5mm

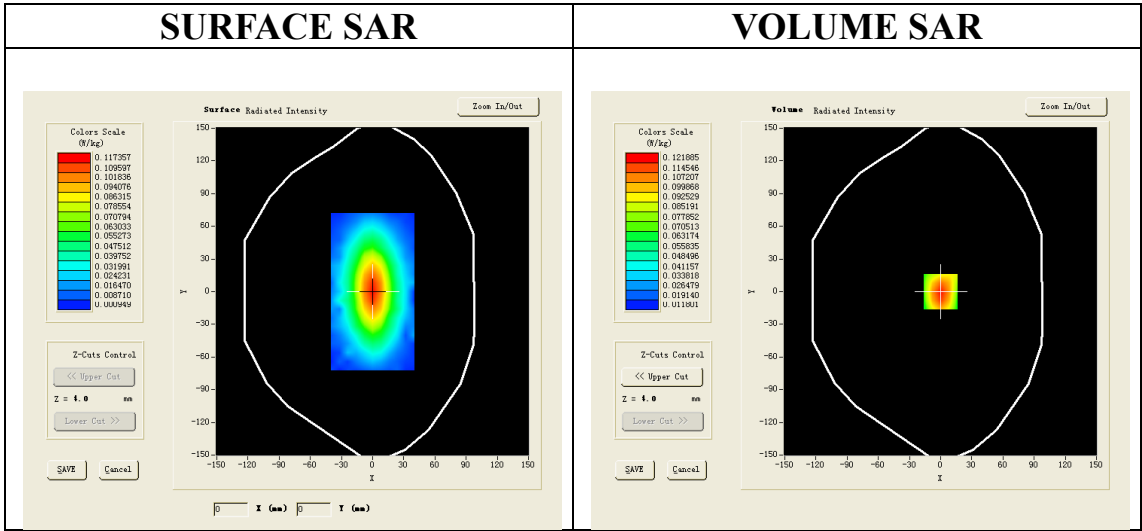

Maximum location: X=0.00, Y=0.00

SAR 10g (W/Kg)	0.069364
SAR 1g (W/Kg)	0.117841

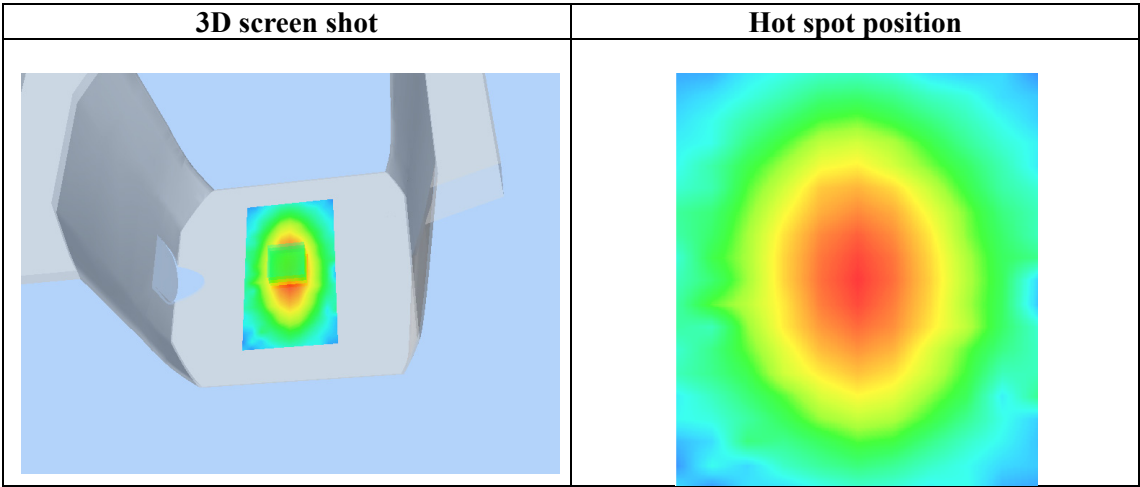
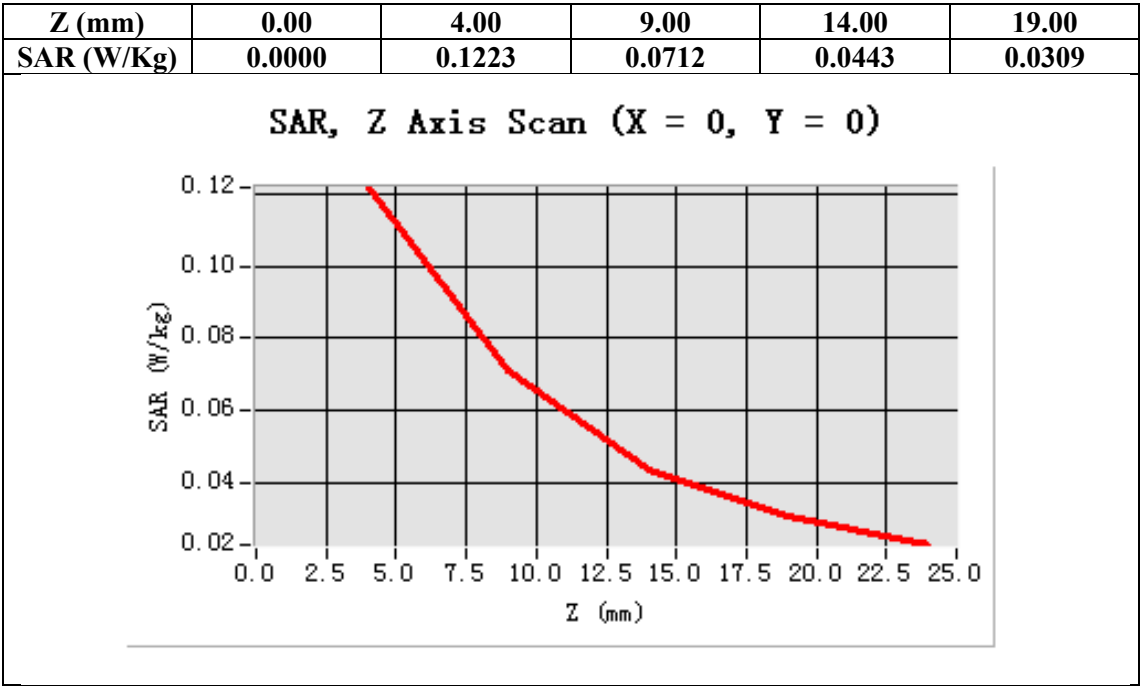

Test Laboratory: AGC Lab
System Check Head 1900MHz

Date: Sep.09, 2013

DUT: Dipole 1900 MHz; Type: SID 1900

Communication System: CW; Communication System Band: D1900 (1900.0 MHz); Duty Cycle:1:1; Conv.F=4.72
Frequency: 1900 MHz; Medium parameters used: $f = 1900$ MHz; $\sigma=1.38$ mho/m; $\epsilon_r =39.87$; $\rho= 1000$ kg/m³ ;
Phantom section: Flat Section; Input Power=10dBm
Ambient temperature (°C): 21, Liquid temperature (°C): 21

SATIMO Configuration:

Probe: EP165; Calibrated: 01/31/2013

- Sensor-Surface: 4mm (Mechanical Surface Detection)
- Phantom: Flat Phantom; Type: Elliptical Phantom
- Measurement SW: OpenSAR V4_02_01

Configuration/System Check PCS1900 Head/Area Scan: Measurement grid: dx=8mm,dy=8mm
Configuration/System Check PCS1900 Head/Zoom Scan: Measurement grid: dx=8mm, dy=8mm, dz=5mm

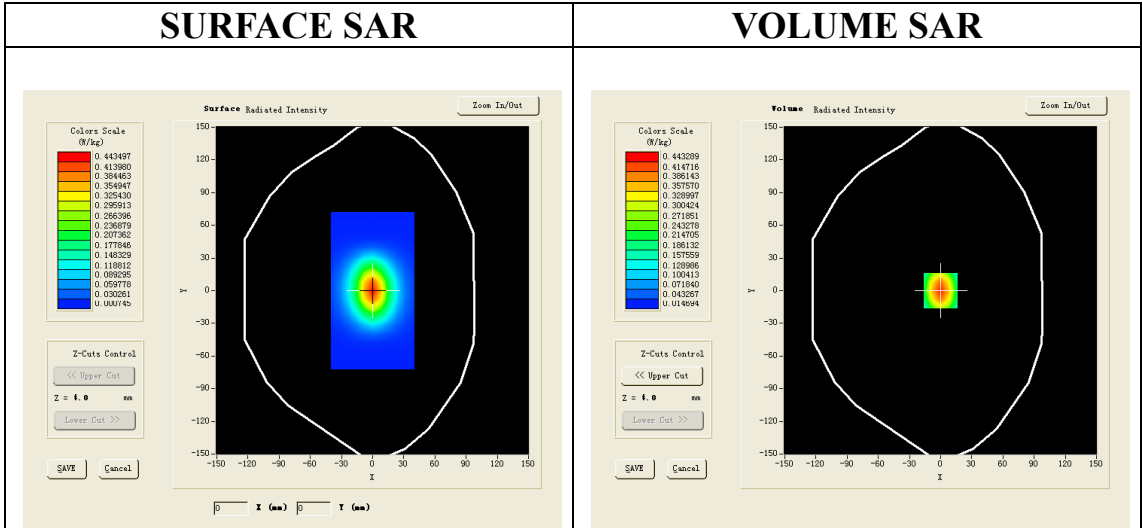

Maximum location: X=0.00, Y=0.00

SAR 10g (W/Kg)	0.213645
SAR 1g (W/Kg)	0.411587

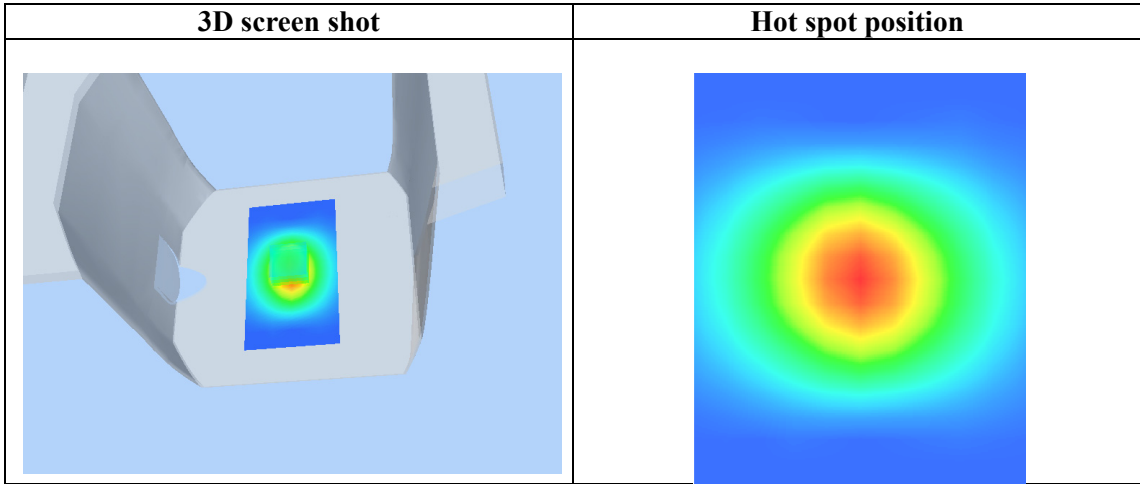
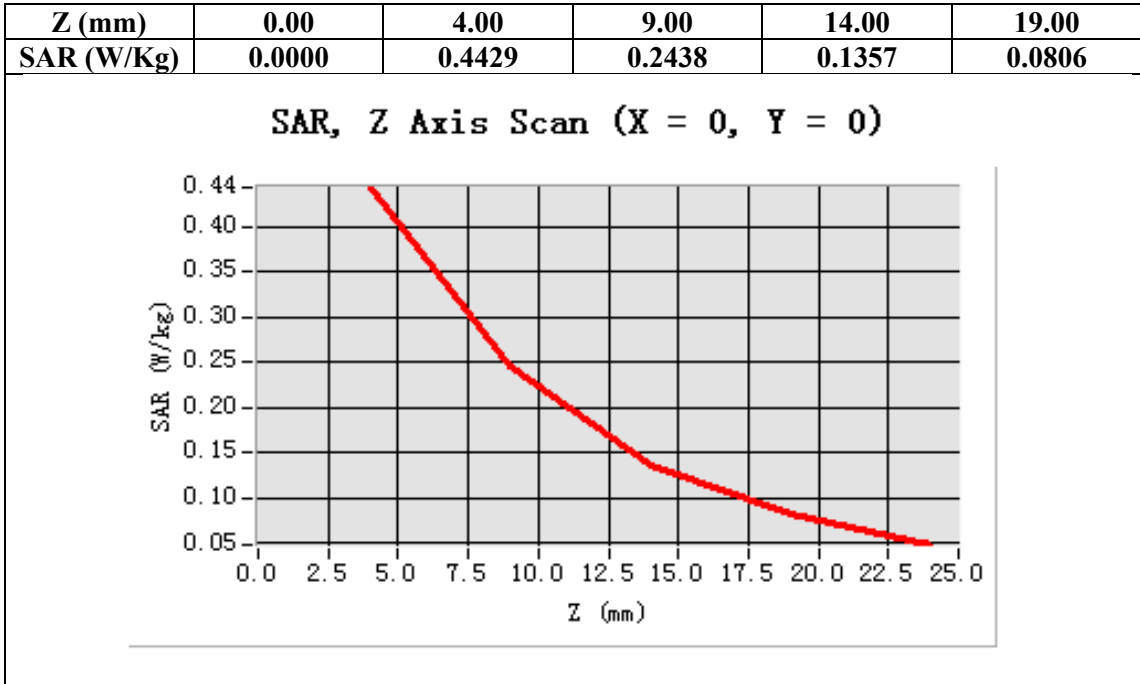

Test Laboratory: AGC Lab
System Check Head 2450 MHz
DUT: Dipole 2450 MHz Type: SID 2450

Date: Sep.09, 2013

Communication System: CW; Communication System Band: D2450 (2450.0 MHz); Duty Cycle: 1:1; Conv.F=4.19
 Frequency: 2450 MHz; Medium parameters used: $f = 2450$ MHz; $\sigma = 1.77$ mho/m; $\epsilon_r = 40.63$; $\rho = 1000$ kg/m³ ;
 Phantom section: Flat Section; Input Power=10dBm
 Ambient temperature (°C): 21, Liquid temperature (°C): 21

SATIMO Configuration:

- Probe: EP165; Calibrated: 01/31/2013
- Sensor-Surface: 4mm (Mechanical Surface Detection)
- Phantom: Flat Phantom; Type: Elliptical Phantom
- Measurement SW: OpenSAR V4_02_01

Configuration/System Check 2450 MHz Head/Area Scan: Measurement grid: dx=8mm,dy=8mm
Configuration/System Check 2450 MHz Head/Zoom Scan: Measurement grid: dx=8mm, dy=8mm, dz=5mm

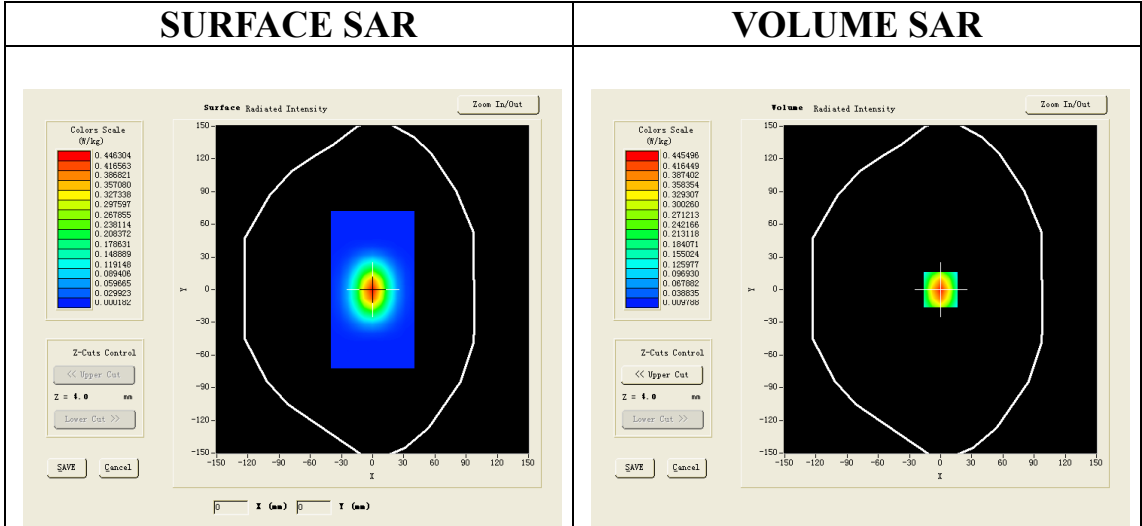

Maximum location: X=0.00, Y=0.00

SAR 10g (W/Kg)	0.254321
SAR 1g (W/Kg)	0.493458

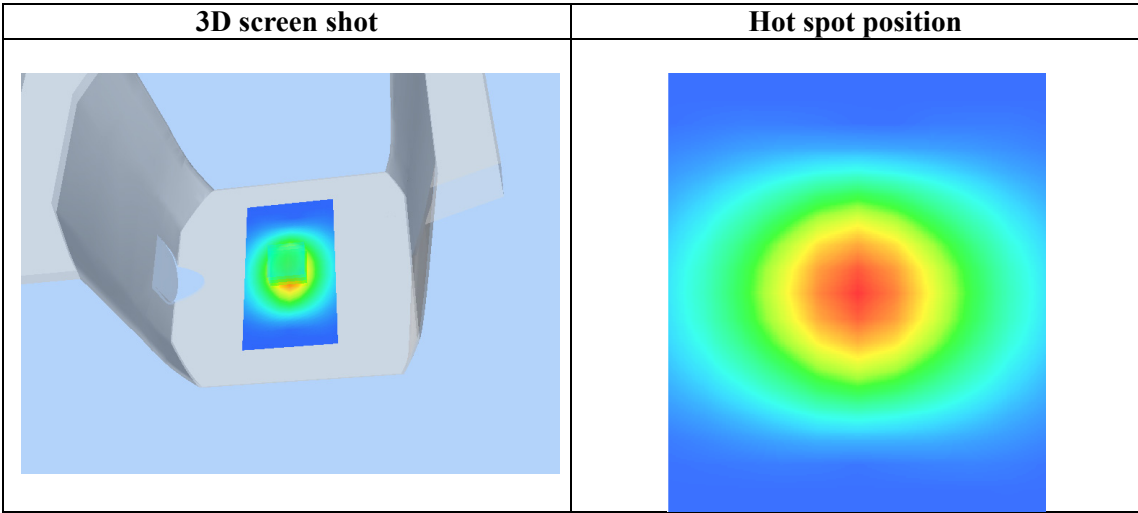
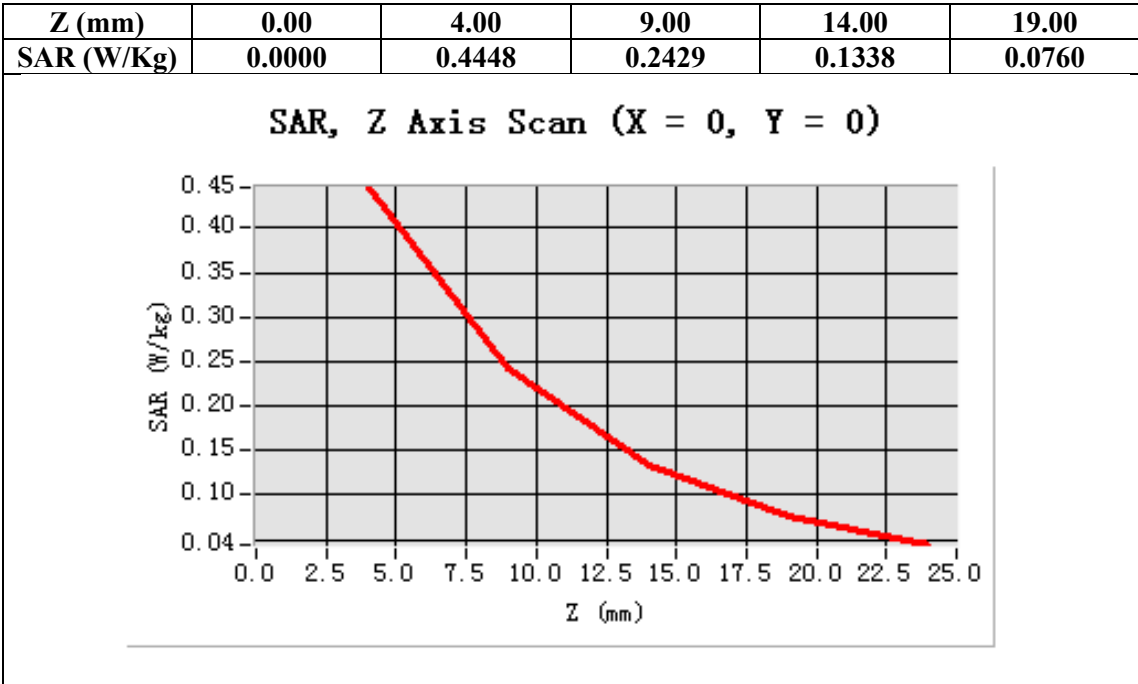

Appendix B. SAR measurement Data

Test Laboratory: AGC Lab
836.52MHz Mid-Touch-Left <SIM 1>

Date: Sep.09, 2013

DUT: CDMA Smart phone; Type: WOW 818

Communication System: Generic; Communication System Band: 836.52MHz; Duty Cycle: 1: 1; Conv.F=5.30
Frequency: 836.52 MHz; Medium parameters used: $f = 835$ MHz; $\sigma=0.88$ mho/m; $\epsilon_r=40.23$; $\rho= 1000$ kg/m³ ;
Phantom section: Left Section
Ambient temperature (°C): 21, Liquid temperature (°C): 21

SATIMO Configuration:

Probe: EP165; Calibrated: 01/31/2013

- Sensor-Surface: 4mm (Mechanical Surface Detection)
- Phantom: Flat Phantom; Type: Elliptical Phantom
- Measurement SW: OpenSAR V4_02_01

Configuration/836.52MHz Mid- Touch-Left/Area Scan (6x8x1): Measurement grid: dx=8mm, dy=8mm
Configuration/836.52MHz Mid- Touch-Left/Zoom Scan (5x5x7)/Cube 0: Measurement grid: dx=8mm, dy=8mm, dz=5mm

Area Scan	sam_direct_droit2_surf8mm.txt
ZoomScan	5x5x7,dx=8mm dy=8mm dz=5mm,Very fast
Phantom	Left head
Device Position	Cheek
Band	836.52MHz
Channels	Middle
Signal	TDMA (Crest factor: 8.0)

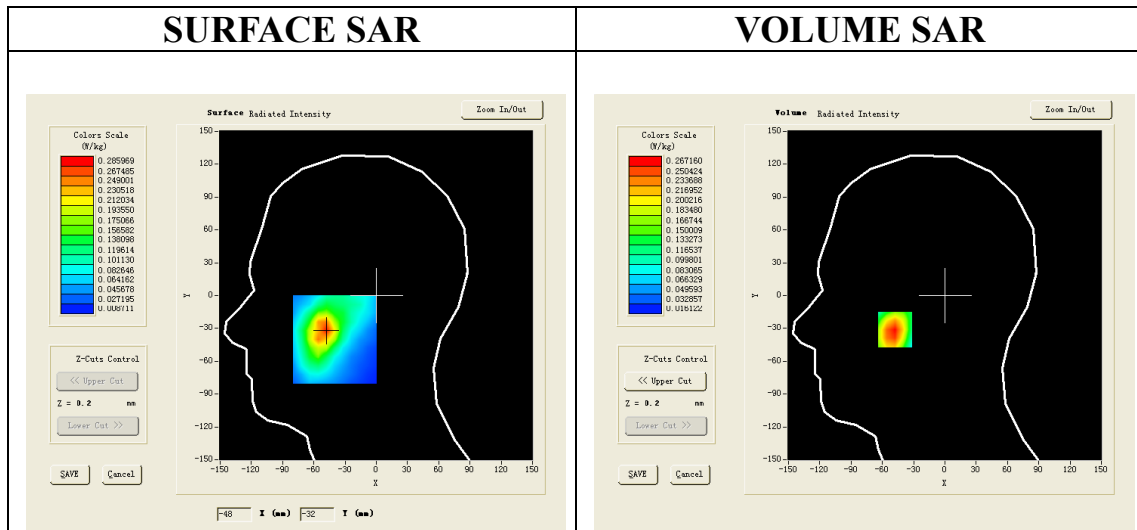

Maximum location: X=-48.00, Y=-31.00

SAR 10g (W/Kg)	0.158236
SAR 1g (W/Kg)	0.256981

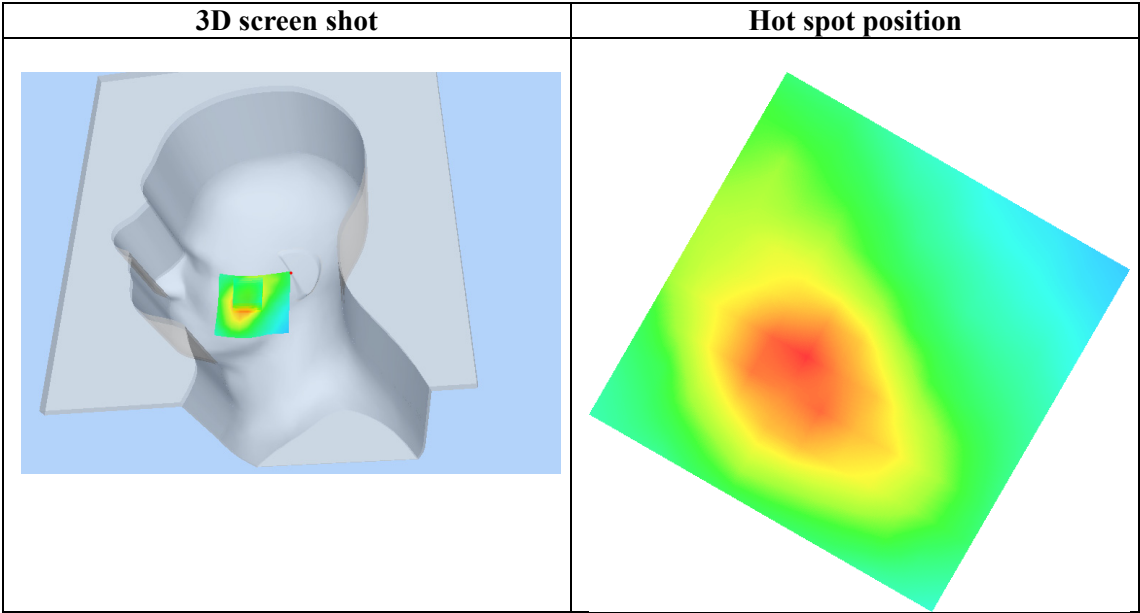
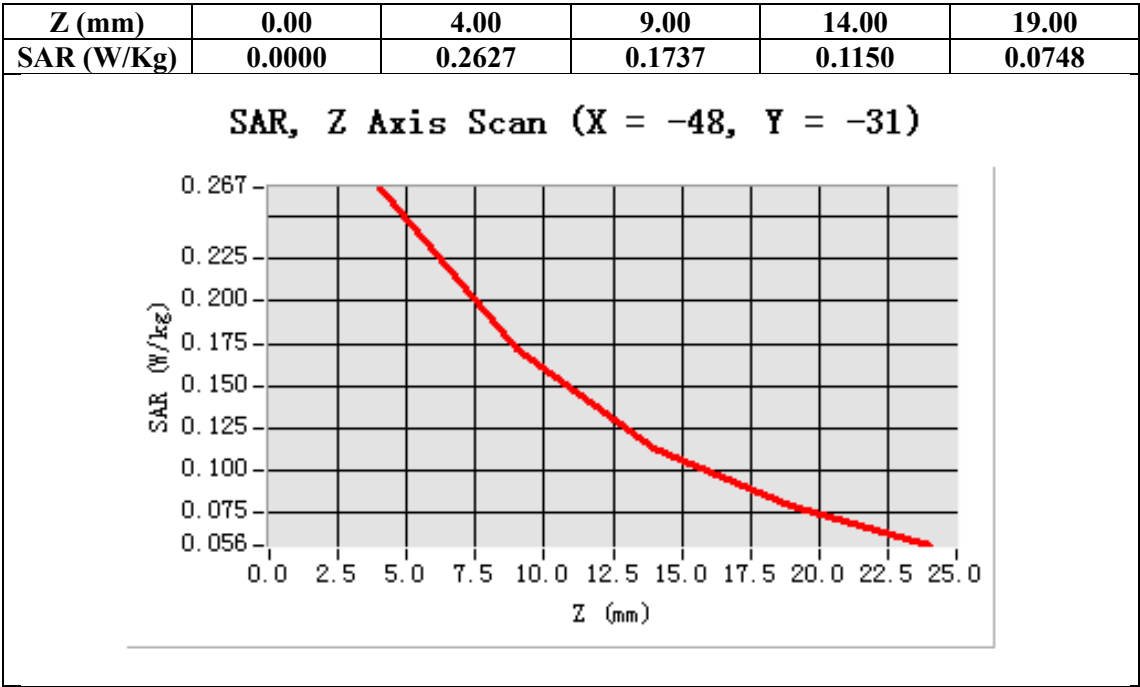

Test Laboratory: AGC Lab
836.52MHz Mid -Tilt-Left <SIM 1>
DUT: CDMA Smart phone; Type: WOW 818

Date: Sep.09, 2013

Communication System: Generic; Communication System Band: 836.52MHz; Duty Cycle: 1: 1; Conv.F=5.30
Frequency: 836.52 MHz; Medium parameters used: $f = 835$ MHz; $\sigma=0.88$ mho/m; $\epsilon_r=40.23$; $\rho= 1000$ kg/m³ ;
Phantom section: Left Section
Ambient temperature (°C): 21, Liquid temperature (°C): 21

SATIMO Configuration:

Probe: EP165; Calibrated: 01/31/2013

- Sensor-Surface: 4mm (Mechanical Surface Detection)
- Phantom: Flat Phantom; Type: Elliptical Phantom
- Measurement SW: OpenSAR V4_02_01

Configuration/836.52MHz Mid- Tilt-Left/Area Scan (6x8x1): Measurement grid: dx=8mm, dy=8mm
Configuration/836.52MHz Mid- Tilt-Left/Zoom Scan (5x5x7)/Cube 0: Measurement grid: dx=8mm, dy=8mm,dz=5mm;

Area Scan	sam_direct_droit2_surf8mm.txt
ZoomScan	5x5x7,dx=8mm dy=8mm dz=5mm,Very fast
Phantom	Left head
Device Position	Tilt
Band	836.52MHz
Channels	Middle
Signal	TDMA (Crest factor: 8.0)

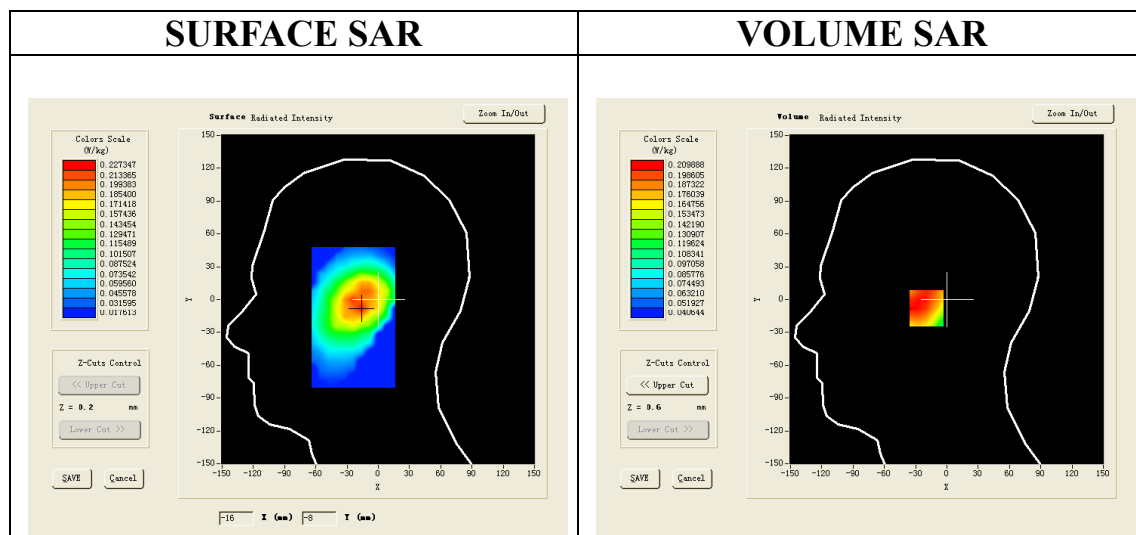

Maximum location: X=-16.00, Y=-8.00

SAR 10g (W/Kg)	0.153985
SAR 1g (W/Kg)	0.206741

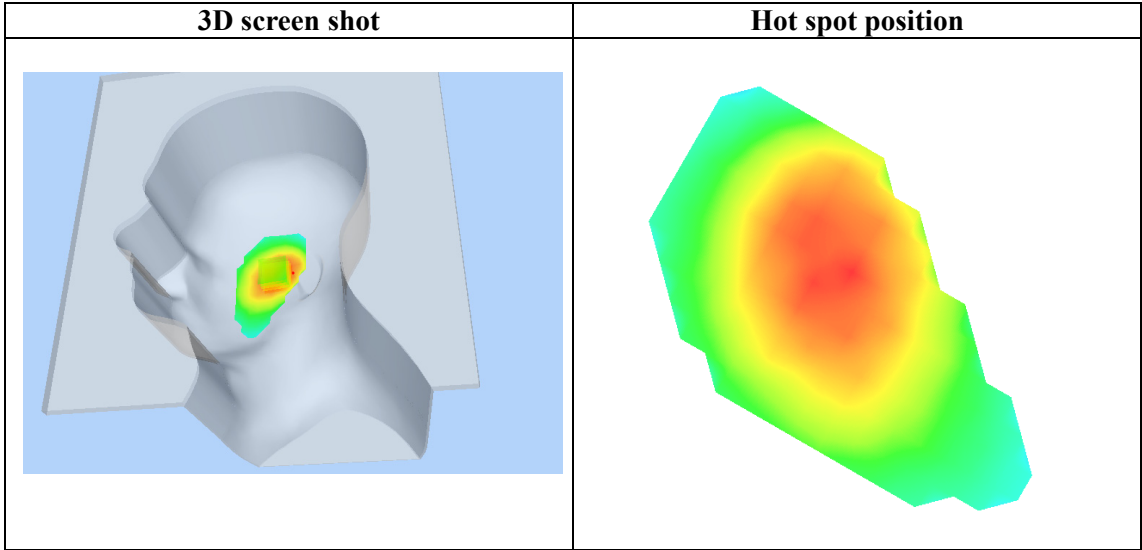
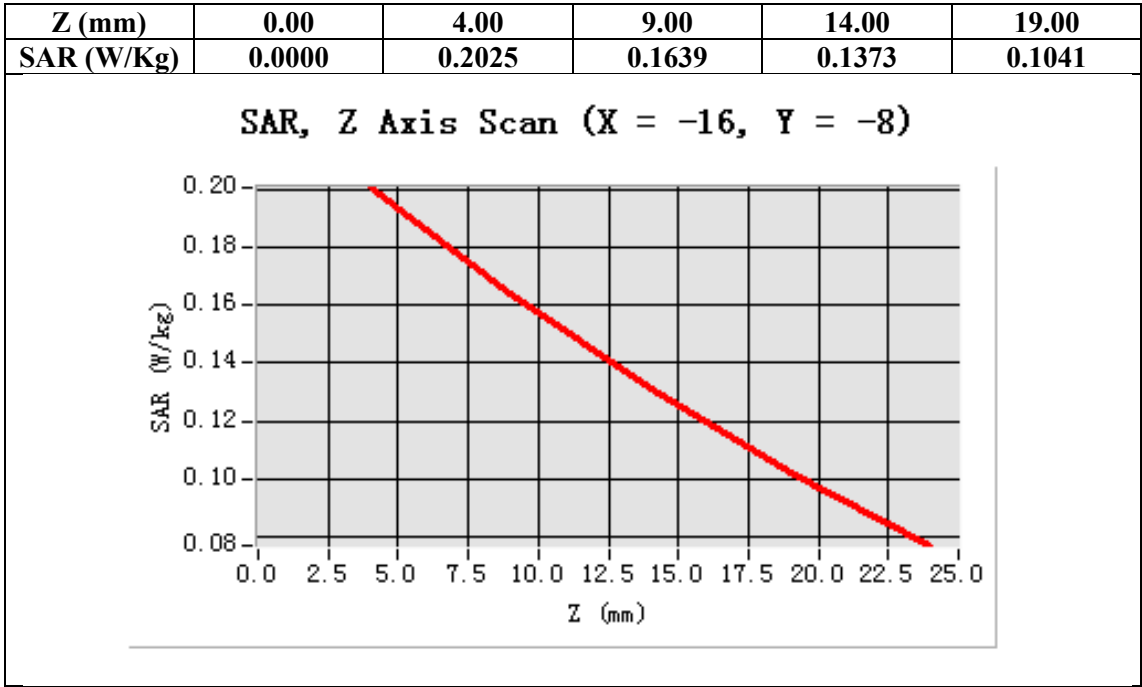

Test Laboratory: AGC Lab
836.52MHz Mid- Touch-Right <SIM 1>
DUT: CDMA Smart phone; Type: WOW 818

Date: Sep.09, 2013

Communication System: Generic; Communication System Band: 836.52MHz; Duty Cycle: 1: 1; Conv.F=5.30
Frequency: 836.52 MHz; Medium parameters used: $f = 835$ MHz; $\sigma=0.88$ mho/m; $\epsilon_r=40.23$; $\rho= 1000$ kg/m³ ;
Phantom section: Right Section
Ambient temperature (°C): 21, Liquid temperature (°C): 21

- SATIMO Configuration:
Probe: EP165; Calibrated: 01/31/2013
- Sensor-Surface: 4mm (Mechanical Surface Detection)
 - Phantom: Flat Phantom; Type: Elliptical Phantom
 - Measurement SW: OpenSAR V4_02_01

Configuration/836.52MHz Mid- Touch-Right /Area Scan: Measurement grid: dx=8mm, dy=8mm
Configuration/836.52MHz Mid- Touch-Right /Zoom Scan: Measurement grid: dx=8mm, dy=8mm, dz=5mm;

Area Scan	sam_direct_droit2_surf8mm.txt
ZoomScan	5x5x7,dx=8mm dy=8mm dz=5mm,Very fast
Phantom	Right head
Device Position	Cheek
Band	836.52MHz
Channels	Middle
Signal	TDMA (Crest factor: 8.0)

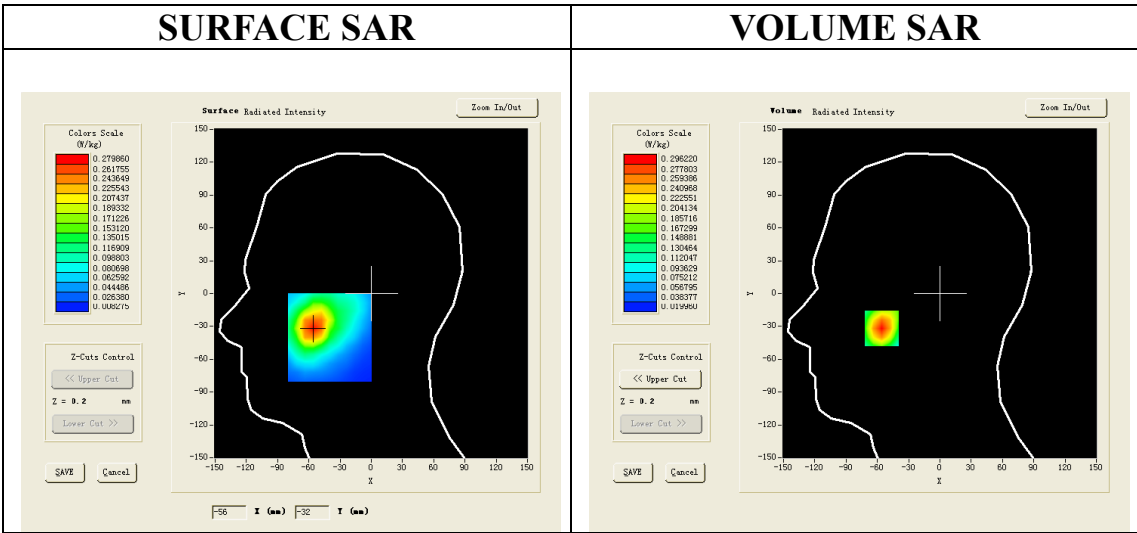

Maximum location: X=-56.00, Y=-32.00

SAR 10g (W/Kg)	0.161740
SAR 1g (W/Kg)	0.273508

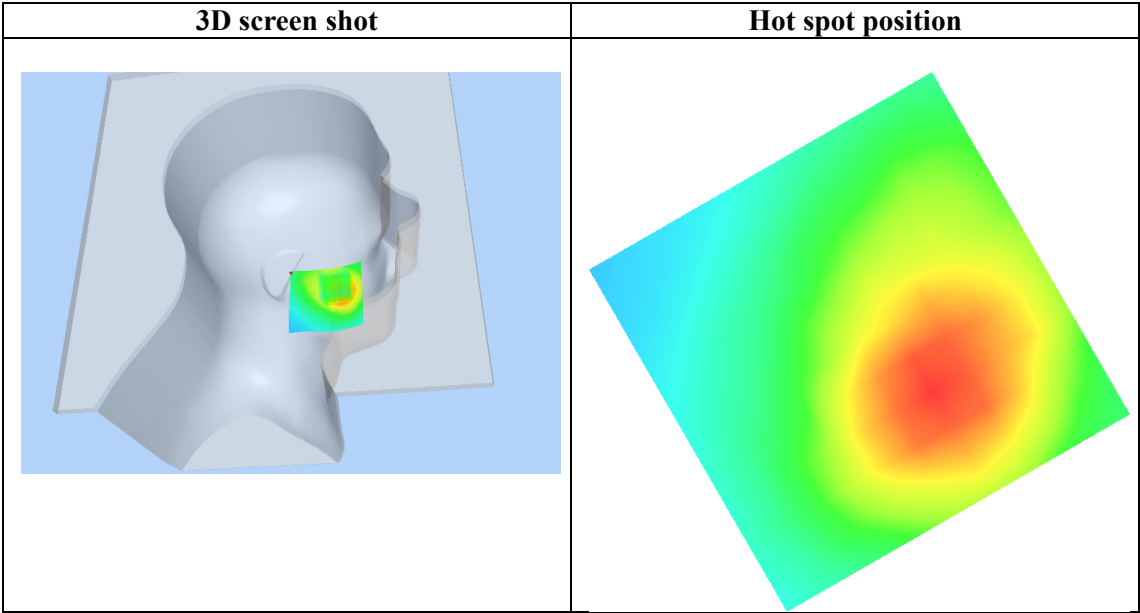
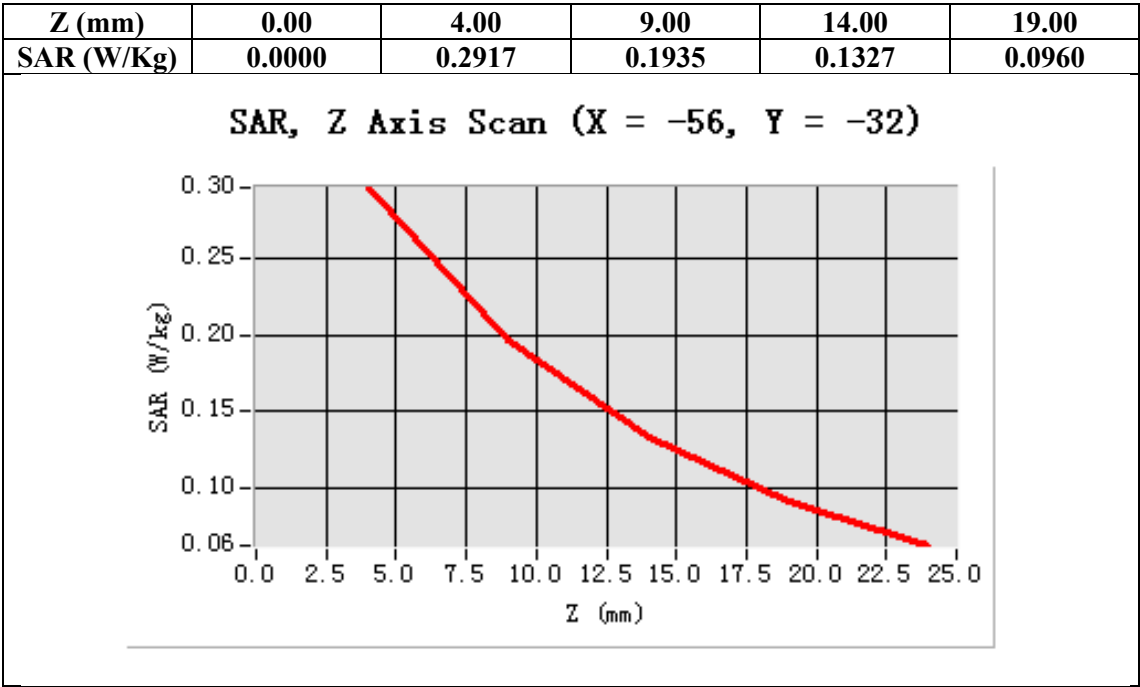

Test Laboratory: AGC Lab
836.52MHz Mid-Tilt-Right <SIM 1>
DUT: CDMA Smart phone; Type: WOW 818

Date: Sep.09, 2013

Communication System: Generic; Communication System Band: 836.52MHz; Duty Cycle: 1: 1; Conv.F=5.30
Frequency: 836.52 MHz; Medium parameters used: $f = 835$ MHz; $\sigma=0.88$ mho/m; $\epsilon_r=40.23$; $\rho= 1000$ kg/m³ ;
Phantom section: Right Section
Ambient temperature (°C): 21, Liquid temperature (°C): 21

- SATIMO Configuration:
Probe: EP165; Calibrated: 01/31/2013
- Sensor-Surface: 4mm (Mechanical Surface Detection)
 - Phantom: Flat Phantom; Type: Elliptical Phantom
 - Measurement SW: OpenSAR V4_02_01

Configuration/836.52MHz Mid- Tilt-Right/Area Scan: Measurement grid: dx=8mm, dy=8mm

Configuration/836.52MHz Mid- Tilt-Right/Zoom Scan: Measurement grid: dx=8mm, dy=8mm, dz=5mm;

Area Scan	sam_direct_droit2_surf8mm.txt
Zoom Scan	5x5x7,dx=8mm dy=8mm dz=5mm,Very fast
Phantom	Right head
Device Position	Tilt
Band	836.52MHz
Channels	Middle
Signal	TDMA (Crest factor: 8.0)

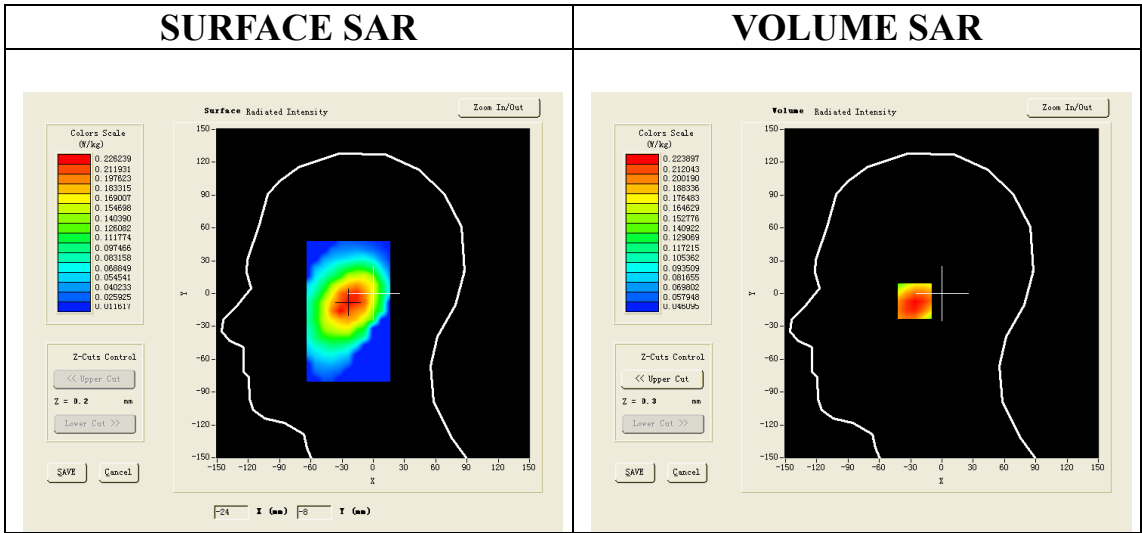

Maximum location: X=-23.00, Y=-7.00

SAR 10g (W/Kg)	0.150852
SAR 1g (W/Kg)	0.213471

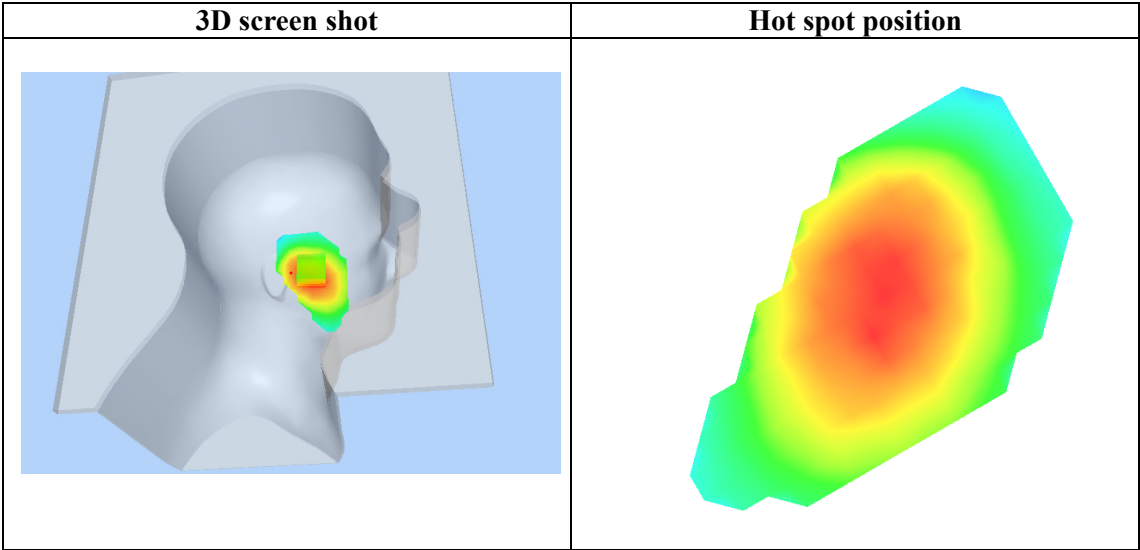
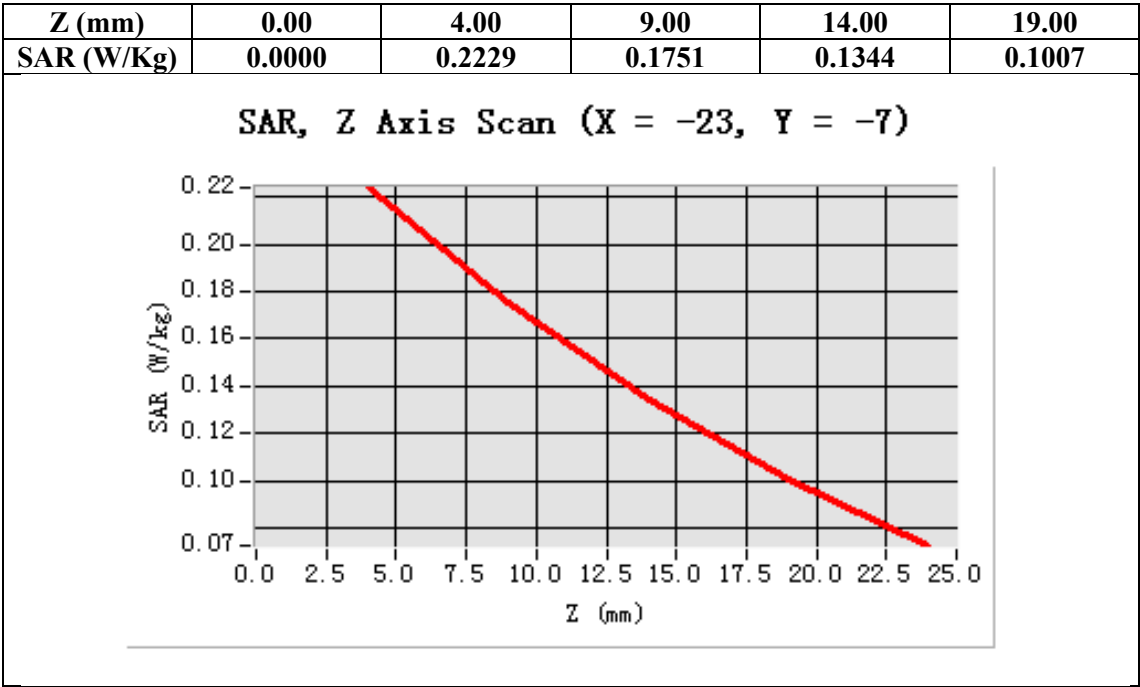

Test Laboratory: AGC Lab
836.52MHz Mid- Touch-Right <SIM 2>
DUT: CDMA Smart phone; Type: WOW 818

Date: Sep.09, 2013

Communication System: Generic; Communication System Band: 836.52MHz; Duty Cycle: 1: 1; Conv.F=5.30
Frequency: 836.52 MHz; Medium parameters used: $f = 835$ MHz; $\sigma=0.88$ mho/m; $\epsilon_r=40.23$; $\rho= 1000$ kg/m³ ;
Phantom section: Right Section
Ambient temperature (°C): 21, Liquid temperature (°C): 21

- SATIMO Configuration:
Probe: EP165; Calibrated: 01/31/2013
- Sensor-Surface: 4mm (Mechanical Surface Detection)
 - Phantom: Flat Phantom; Type: Elliptical Phantom
 - Measurement SW: OpenSAR V4_02_01

Configuration/836.52MHz Mid- Touch-Right /Area Scan: Measurement grid: dx=8mm, dy=8mm
Configuration/836.52MHz Mid- Touch-Right /Zoom Scan: Measurement grid: dx=8mm, dy=8mm, dz=5mm;

Area Scan	sam_direct_droit2_surf8mm.txt
ZoomScan	5x5x7,dx=8mm dy=8mm dz=5mm,Very fast
Phantom	Right head
Device Position	Cheek
Band	836.52MHz
Channels	Middle
Signal	TDMA (Crest factor: 8.0)

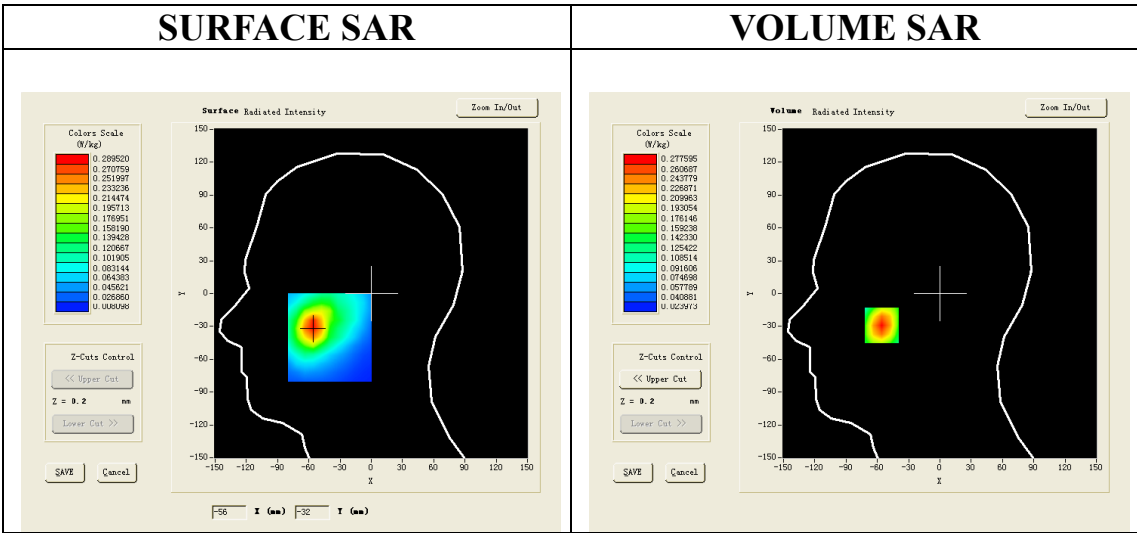

Maximum location: X=-56.00, Y=-29.00

SAR 10g (W/Kg)	0.166654
SAR 1g (W/Kg)	0.260645

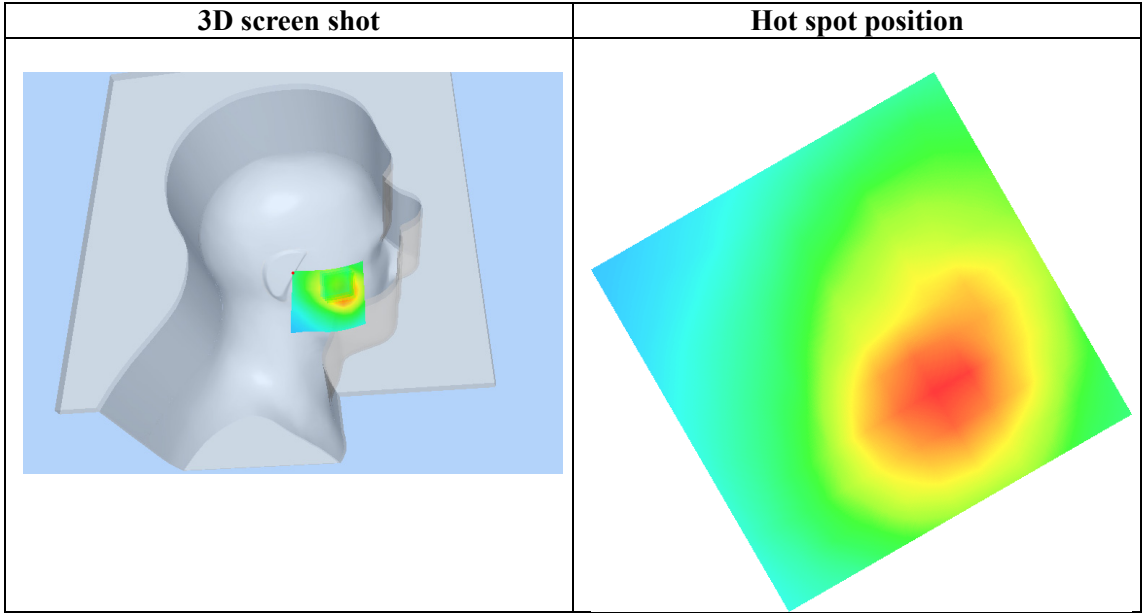
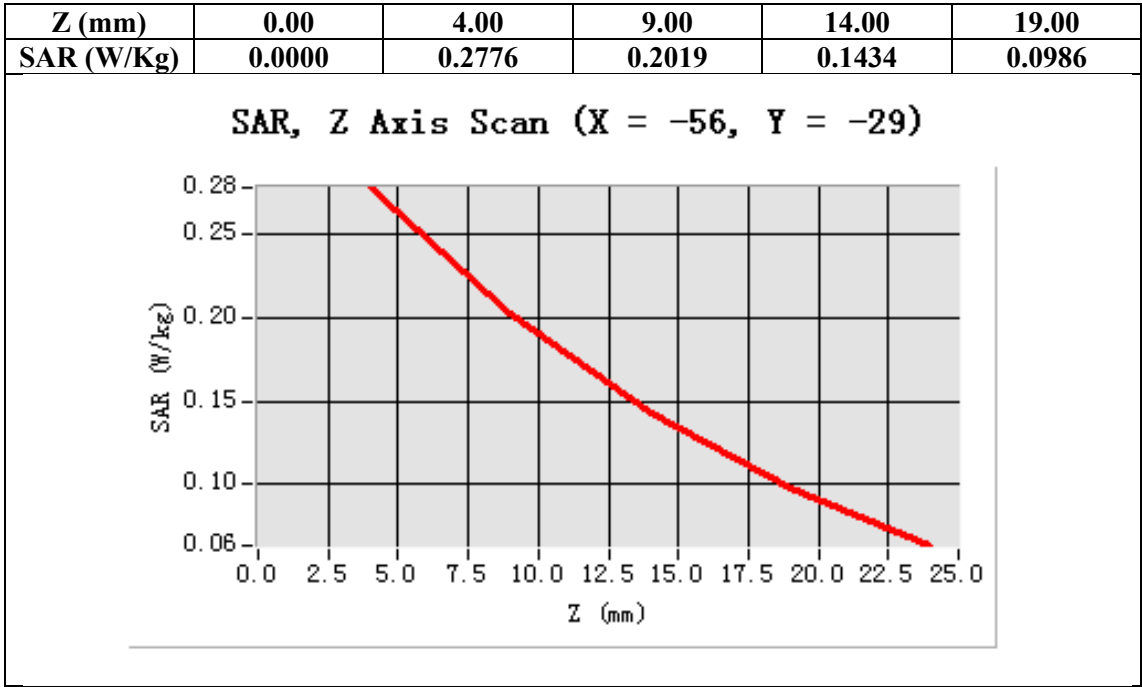

Test Laboratory: AGC Lab
836.52MHz Mid-Body-Worn- Back (MS) <SIM 1>
DUT: CDMA Smart phone; Type: WOW 818

Date: Sep.09, 2013

Communication System: Generic; Communication System Band: 836.52MHz; Duty Cycle: 1: 1; Conv.F=5.46
Frequency: 836.52 MHz; Medium parameters used: $f = 835$ MHz; $\sigma=0.96$ mho/m; $\epsilon_r=53.62$; $\rho= 1000$ kg/m³ ;
Phantom section: Flat Section
Ambient temperature (°C):21, Liquid temperature (°C):21

- SATIMO Configuration:
Probe: EP165; Calibrated: 01/31/2013
- Sensor-Surface: 4mm (Mechanical Surface Detection)
 - Phantom: Flat Phantom; Type: Elliptical Phantom
 - Measurement SW: OpenSAR V4_02_01

Configuration/836.52MHz Mid- Body- Back /Area Scan (6x8x1): Measurement grid: dx=8mm, dy=8mm
Configuration/836.52MHz Mid- Body- Back /Zoom Scan (5x5x7)/Cube 0: Measurement grid: dx=8mm, dy=8mm, dz=5mm;

Area Scan	surf_sam_plan.txt
ZoomScan	5x5x7,dx=8mm dy=8mm dz=5mm,Very fast
Phantom	Validation plane
Device Position	Body Back
Band	836.52MHz
Channels	Middle
Signal	TDMA (Crest factor: 8.0)

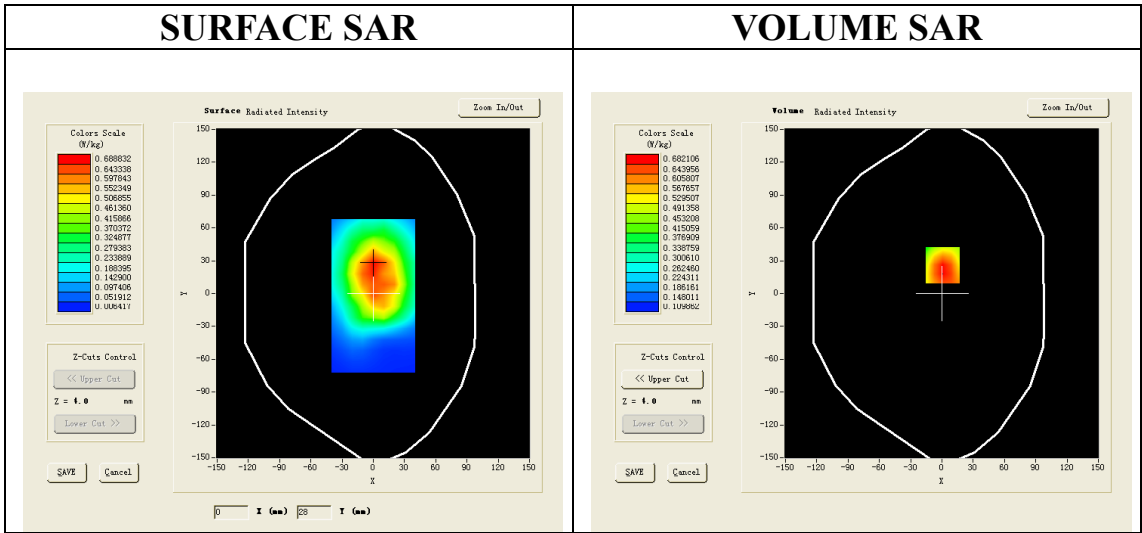

Maximum location: X=1.00, Y=26.00

SAR 10g (W/Kg)	0.479450
SAR 1g (W/Kg)	0.711618

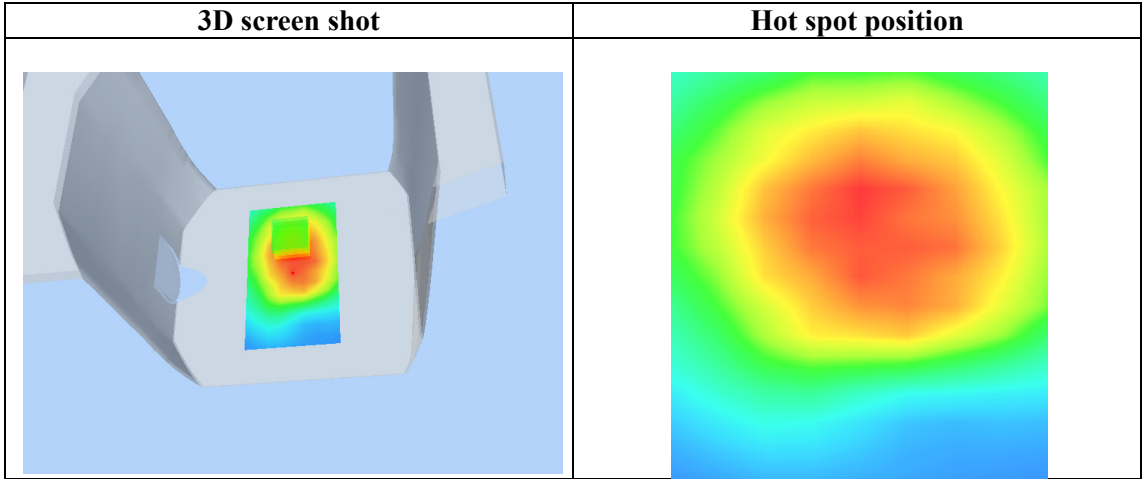
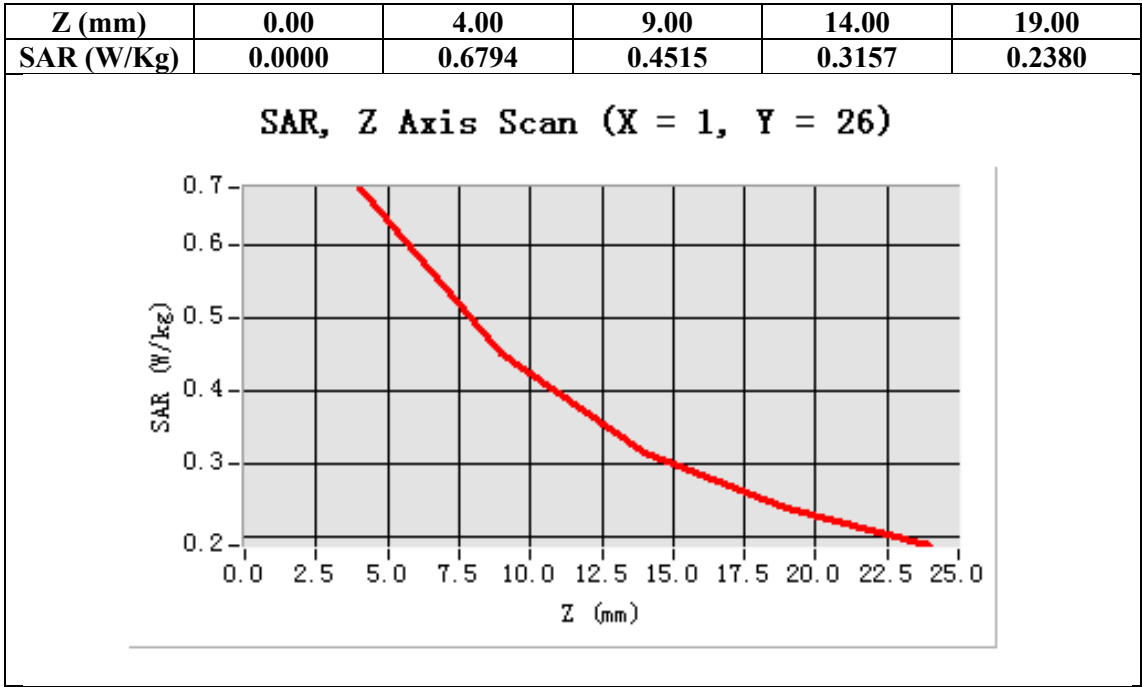

Test Laboratory: AGC Lab
836.52MHz Mid-Body- Worn- Front (MS) <SIM 1>
DUT: CDMA Smart phone; Type: WOW 818

Date: Sep.09, 2013

Communication System: Generic; Communication System Band: 836.52MHz; Duty Cycle: 1: 1; Conv.F=5.46
Frequency: 836.52 MHz; Medium parameters used: $f = 835$ MHz; $\sigma=0.96$ mho/m; $\epsilon_r = 53.62$; $\rho = 1000$ kg/m³ ;
Phantom section: Flat Section
Ambient temperature (°C):21, Liquid temperature (°C):21

SATIMO Configuration:

- Probe: EP165; Calibrated: 01/31/2013
- Sensor-Surface: 4mm (Mechanical Surface Detection)
- Phantom: Flat Phantom; Type: Elliptical Phantom
- Measurement SW: OpenSAR V4_02_01

Configuration/836.52MHz Mid- Body- Front /Area Scan (6x8x1): Measurement grid: dx=8mm, dy=8mm
Configuration/836.52MHz Mid- Body- Front /Zoom Scan (5x5x7)/Cube 0: Measurement grid: dx=8mm, dy=8mm, dz=5mm;

Area Scan	surf_sam_plan.txt
ZoomScan	5x5x7,dx=8mm dy=8mm dz=5mm,Very fast
Phantom	Validation plane
Device Position	Body Front
Band	836.52MHz
Channels	Middle
Signal	TDMA (Crest factor: 8.0)

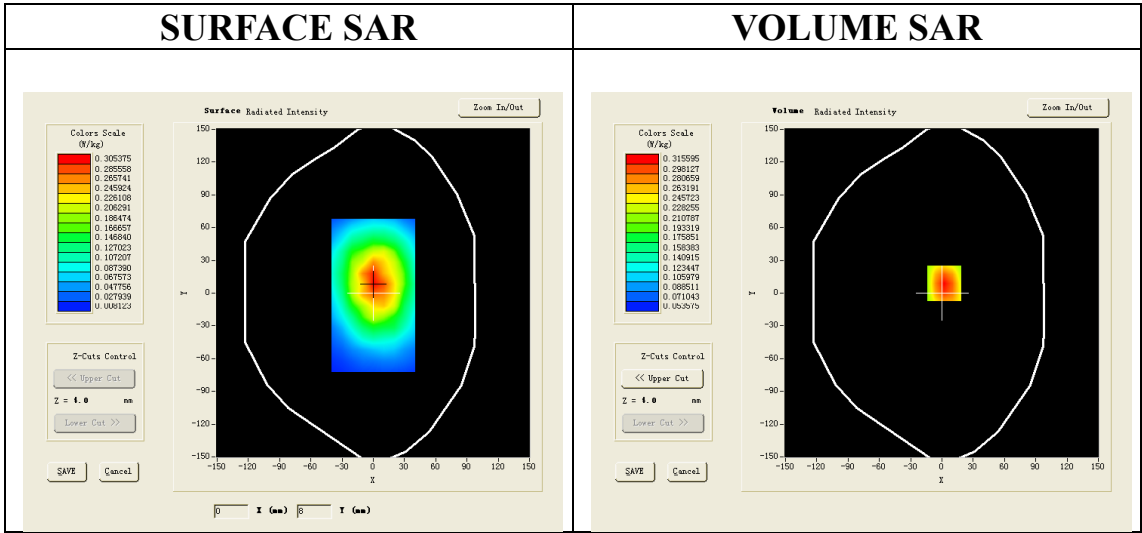

Maximum location: X=2.00, Y=9.00

SAR 10g (W/Kg)	0.216322
SAR 1g (W/Kg)	0.324538

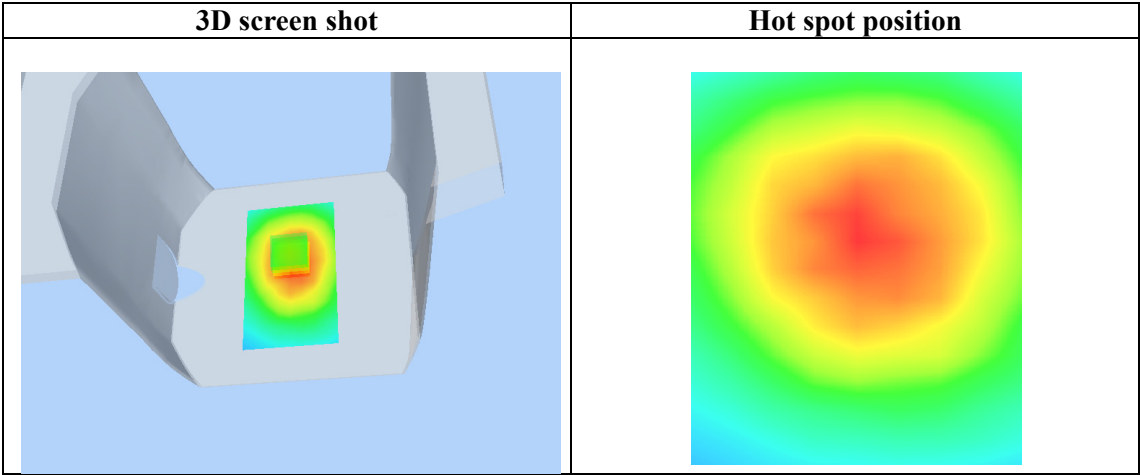
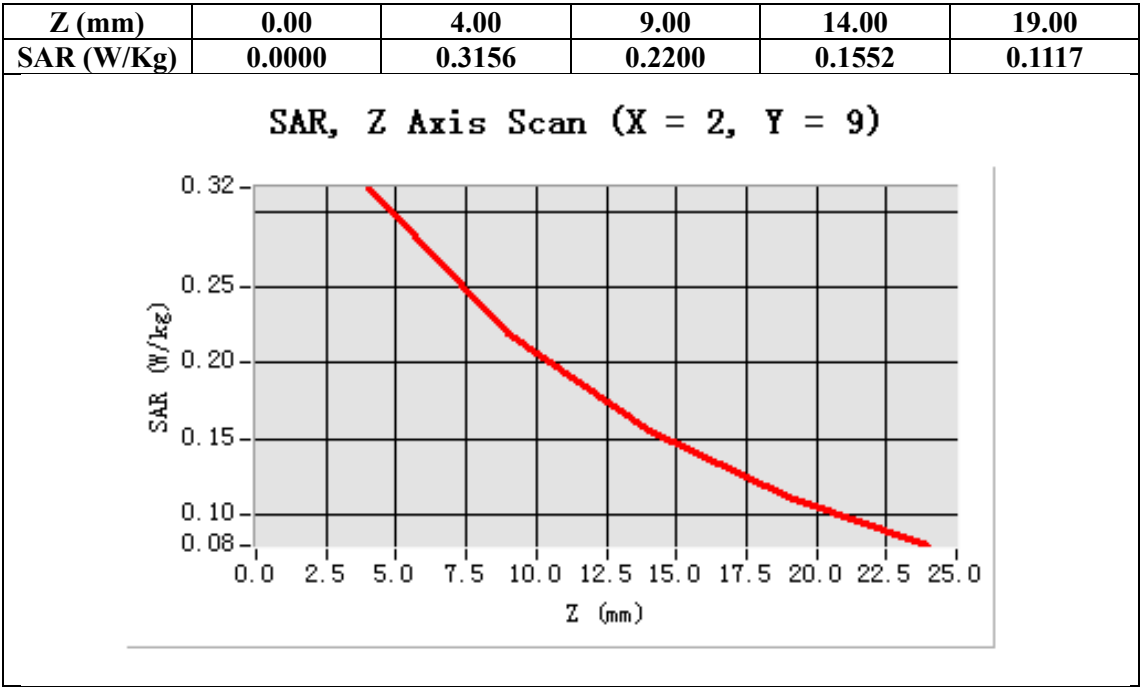

Test Laboratory: AGC Lab
1880MHz Mid-Touch-Left <SIM 1>
DUT: CDMA Smart phone; Type: WOW 818

Date: Sep.09, 2013

Communication System: Generic; Communication System Band: 1880MHz; Duty Cycle: 1: 1; Conv.F=4.72
Frequency: 1880 MHz; Medium parameters used: $f = 1880$ MHz; $\sigma = 1.38$ mho/m; $\epsilon_r = 39.87$; $\rho = 1000$ kg/m³ ;
Phantom section: Left Section
Ambient temperature (°C): 21, Liquid temperature (°C): 21

- SATIMO Configuration:
Probe: EP165; Calibrated: 01/31/2013
- Sensor-Surface: 4mm (Mechanical Surface Detection)
 - Phantom: Flat Phantom; Type: Elliptical Phantom
 - Measurement SW: OpenSAR V4_02_01

Configuration/1880MHz Mid- Touch-Left/Area Scan (6x8x1): Measurement grid: dx=8mm, dy=8mm
Configuration/1880MHz Mid- Touch-Left/Zoom Scan (5x5x7)/Cube 0: Measurement grid: dx=8mm, dy=8mm, dz=5mm

Area Scan	sam_direct_droit2_surf8mm.txt
ZoomScan	5x5x7,dx=8mm dy=8mm dz=5mm,Very fast
Phantom	Left head
Device Position	Cheek
Band	1880MHz
Channels	Middle
Signal	TDMA (Crest factor: 8.0)

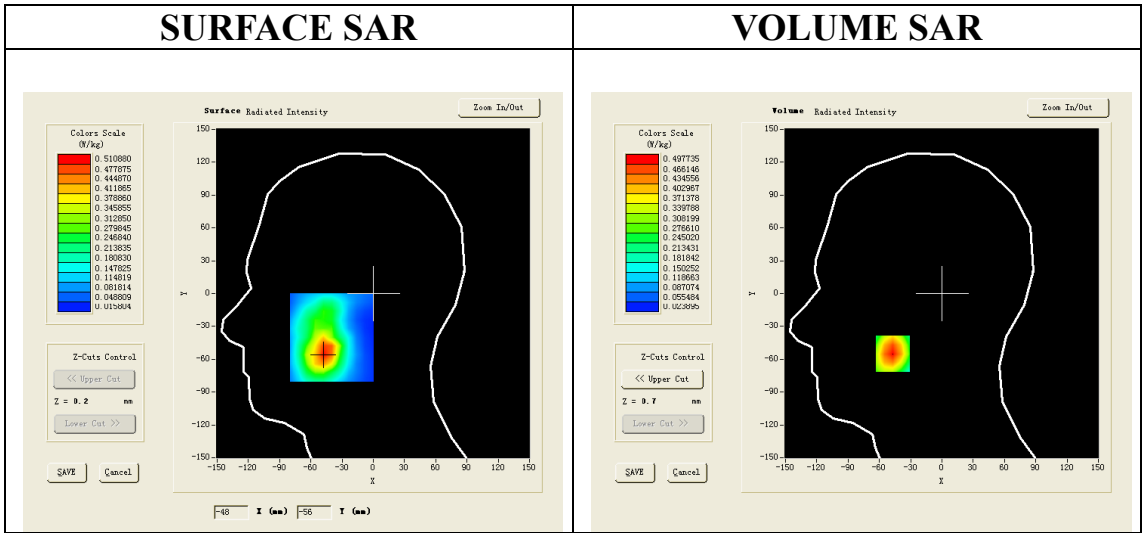

Maximum location: X=-47.00, Y=-55.00

SAR 10g (W/Kg)	0.269036
SAR 1g (W/Kg)	0.475824

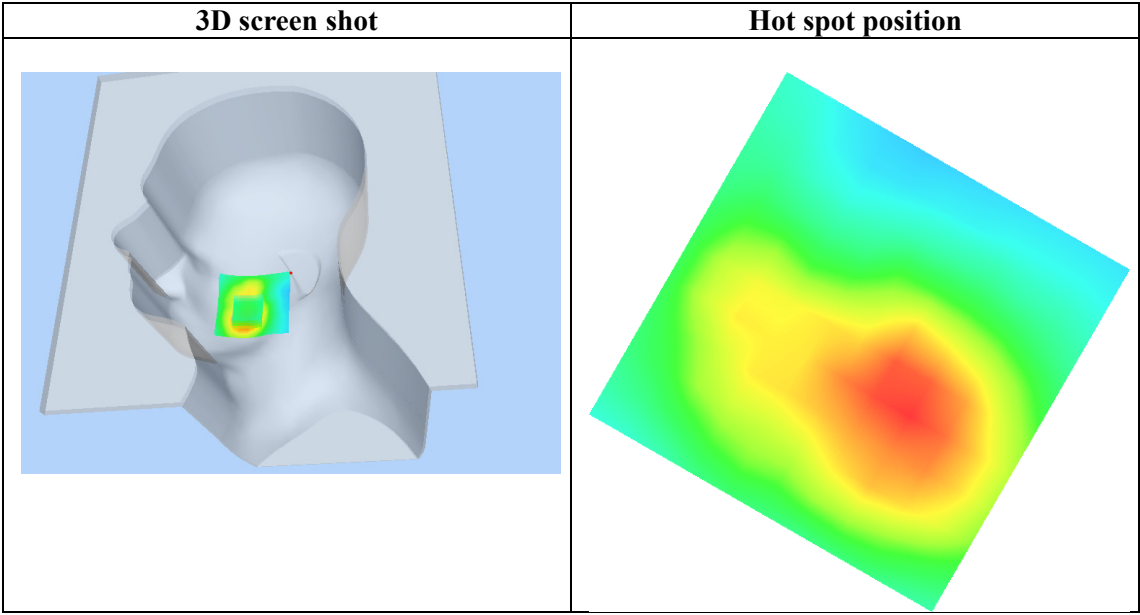
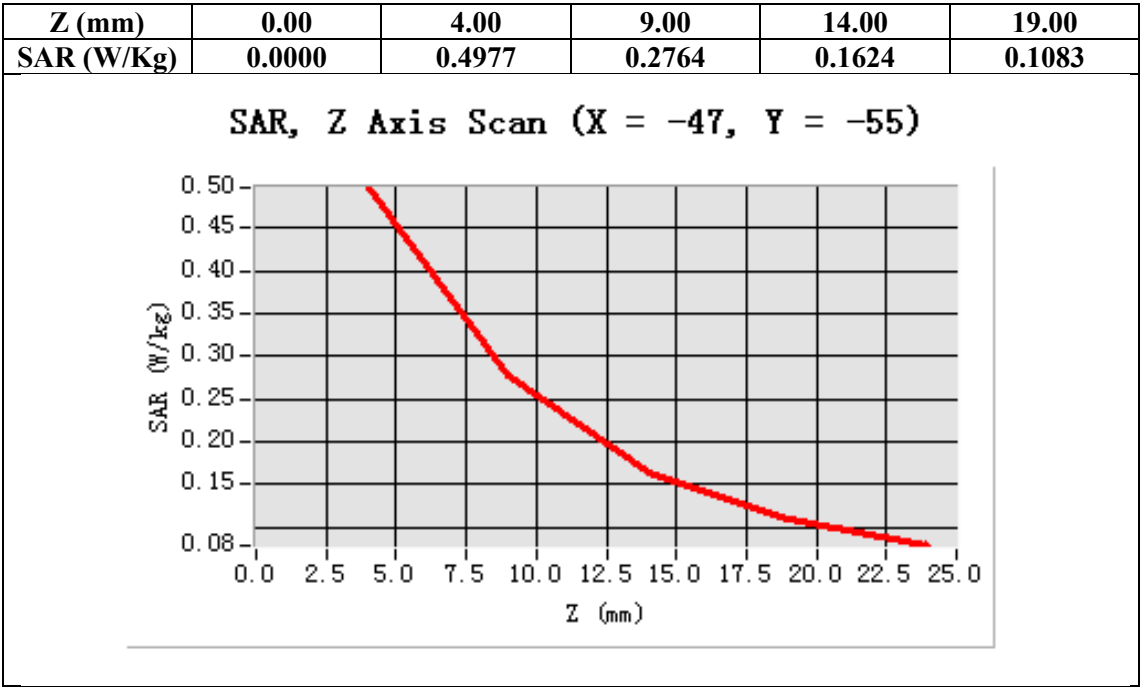

Test Laboratory: AGC Lab
1880MHz Mid -Tilt-Left <SIM 1>

Date: Sep.09, 2013

DUT: CDMA Smart phone; Type: WOW 818

Communication System: Generic; Communication System Band: 1880MHz; Duty Cycle: 1: 1; Conv.F=4.72
Frequency: 1880 MHz; Medium parameters used: $f = 1880$ MHz; $\sigma = 1.38$ mho/m; $\epsilon_r = 39.87$; $\rho = 1000$ kg/m³ ;
Phantom section: Left Section
Ambient temperature (°C): 21, Liquid temperature (°C): 21

SATIMO Configuration:

Probe: EP165; Calibrated: 01/31/2013

- Sensor-Surface: 4mm (Mechanical Surface Detection)
- Phantom: Flat Phantom; Type: Elliptical Phantom
- Measurement SW: OpenSAR V4_02_01

Configuration/1880MHz Mid- Tilt-Left/Area Scan (6x8x1): Measurement grid: dx=8mm, dy=8mm
Configuration/1880MHz Mid- Tilt-Left/Zoom Scan (5x5x7)/Cube 0: Measurement grid: dx=8mm, dy=8mm,dz=5mm;

Area Scan	sam_direct_droit2_surf8mm.txt
ZoomScan	5x5x7,dx=8mm dy=8mm dz=5mm,Very fast
Phantom	Left head
Device Position	Tilt
Band	1880MHz
Channels	Middle
Signal	TDMA (Crest factor: 8.0)

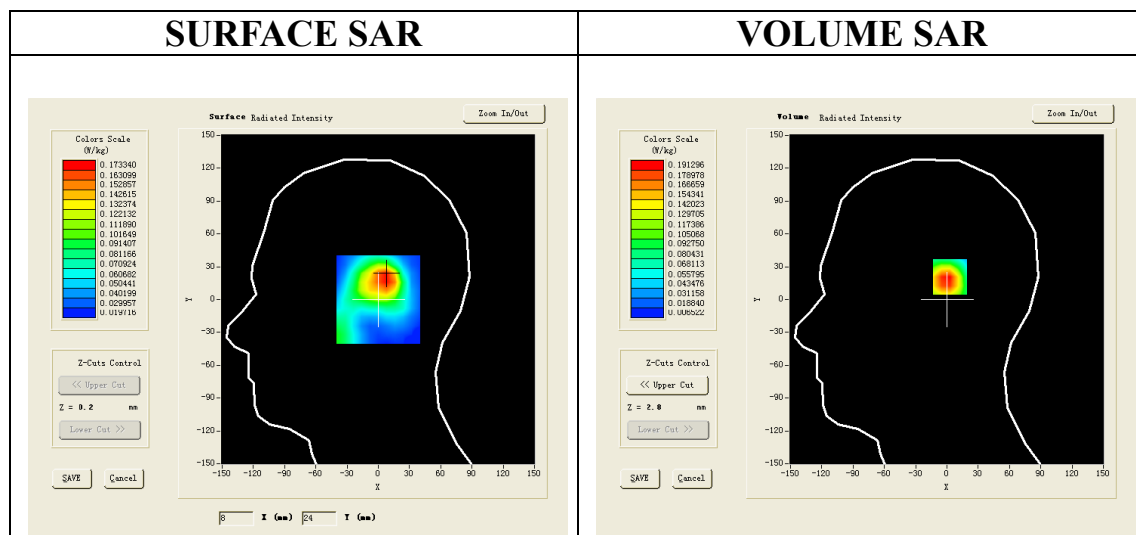

Maximum location: X=7.00, Y=21.00

SAR 10g (W/Kg)	0.105205
SAR 1g (W/Kg)	0.183964

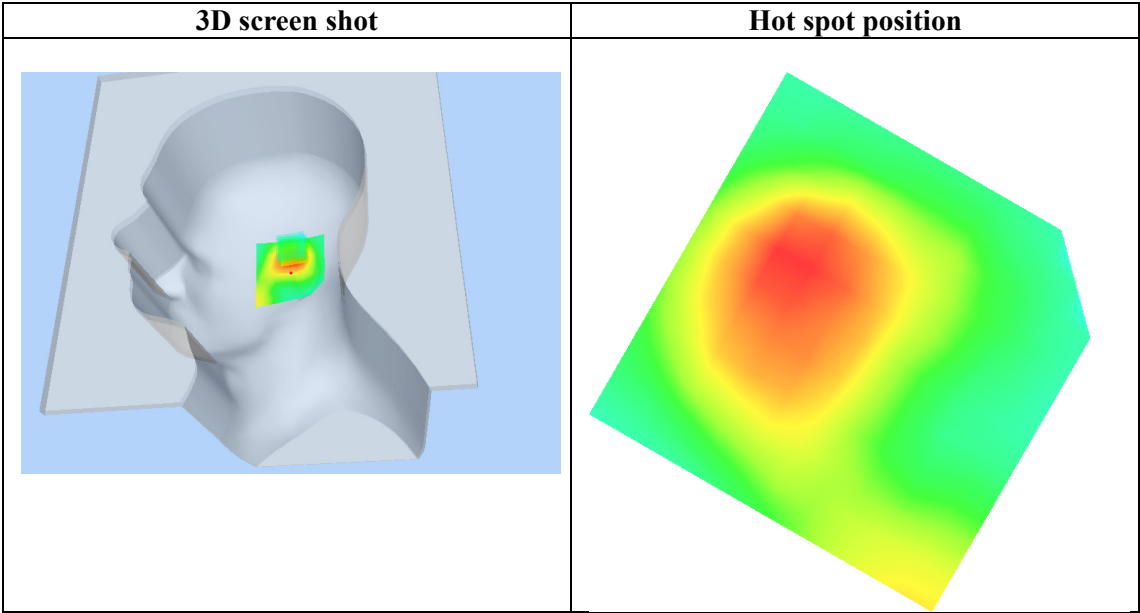
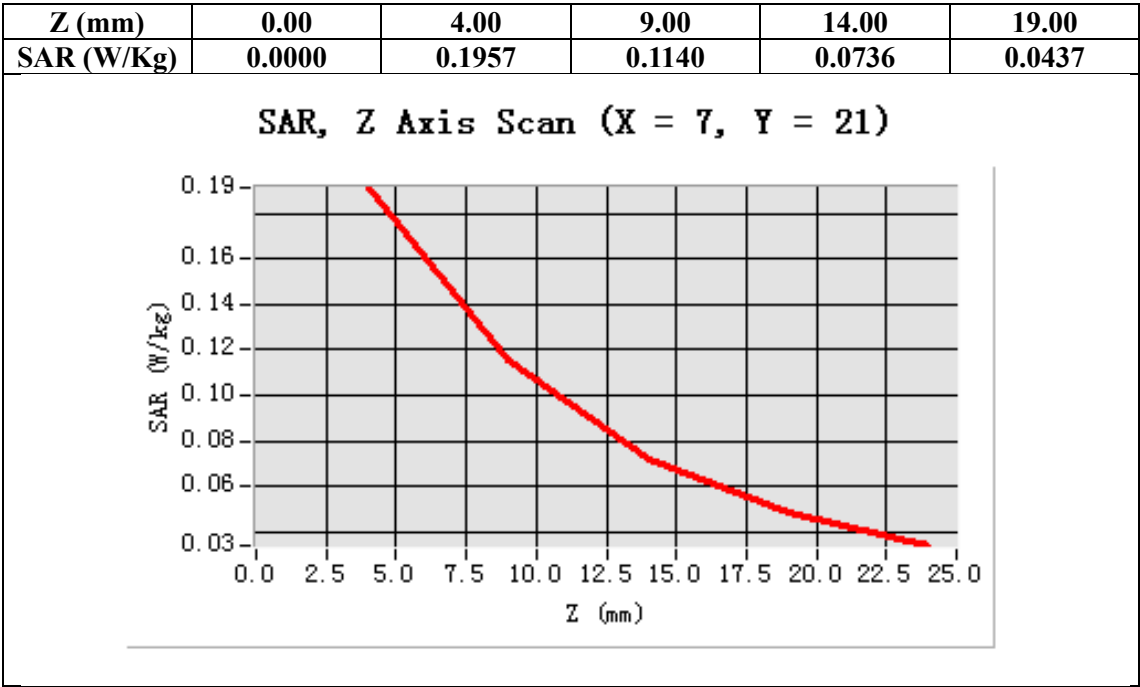

Test Laboratory: AGC Lab
1880MHz Mid- Touch-Right <SIM 1>
DUT: CDMA Smart phone; Type: WOW 818

Date: Sep.09, 2013

Communication System: Generic; Communication System Band: 1880MHz; Duty Cycle: 1: 1; Conv.F=4.72
Frequency: 1880 MHz; Medium parameters used: $f = 1880$ MHz; $\sigma = 1.38$ mho/m; $\epsilon_r = 39.87$; $\rho = 1000$ kg/m³ ;
Phantom section: Right Section
Ambient temperature (°C): 21, Liquid temperature (°C): 21

SATIMO Configuration:

Probe: EP165; Calibrated: 01/31/2013

- Sensor-Surface: 4mm (Mechanical Surface Detection)
- Phantom: Flat Phantom; Type: Elliptical Phantom
- Measurement SW: OpenSAR V4_02_01

Configuration/1880MHz Mid- Touch-Right /Area Scan: Measurement grid: dx=8mm, dy=8mm

Configuration/1880MHz Mid- Touch-Right /Zoom Scan: Measurement grid: dx=8mm, dy=8mm, dz=5mm;

Area Scan	sam_direct_droit2_surf8mm.txt
ZoomScan	5x5x7,dx=8mm dy=8mm dz=5mm,Very fast
Phantom	Right head
Device Position	Cheek
Band	1880MHz
Channels	Middle
Signal	TDMA (Crest factor: 8.0)

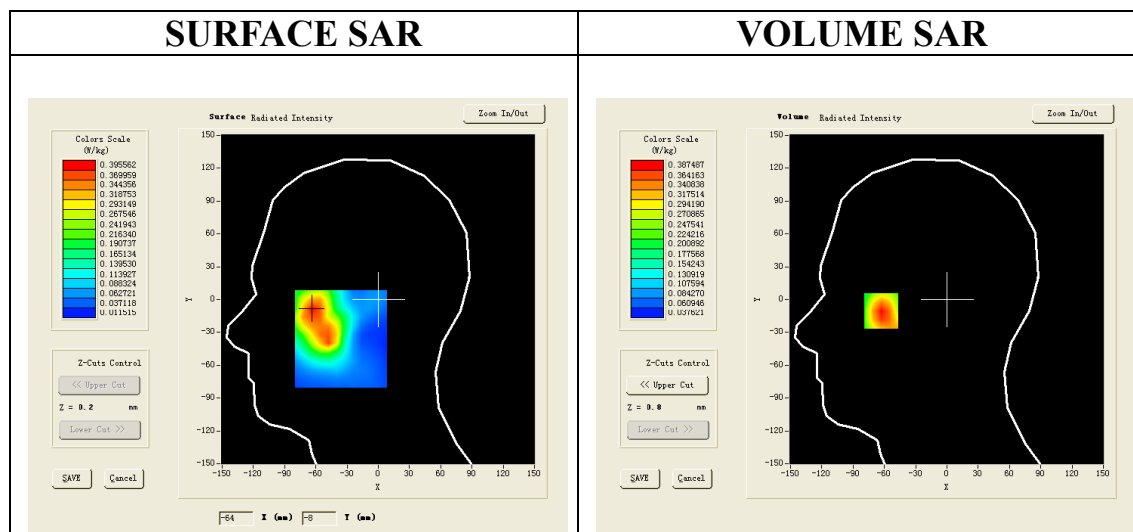

Maximum location: X=-63.00, Y=-9.00

SAR 10g (W/Kg)	0.226952
SAR 1g (W/Kg)	0.364715

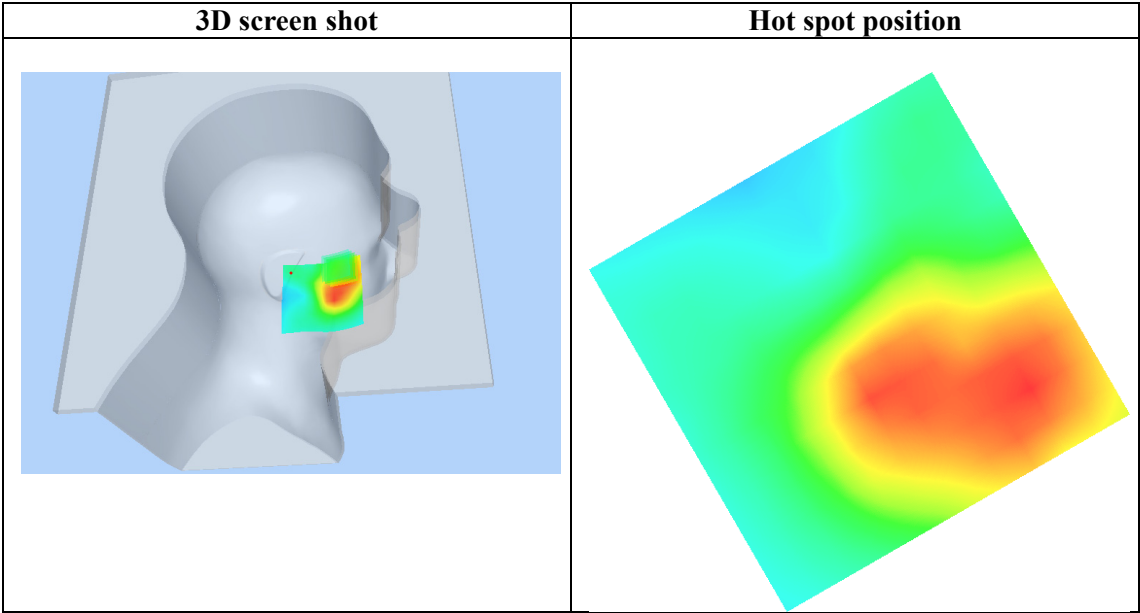
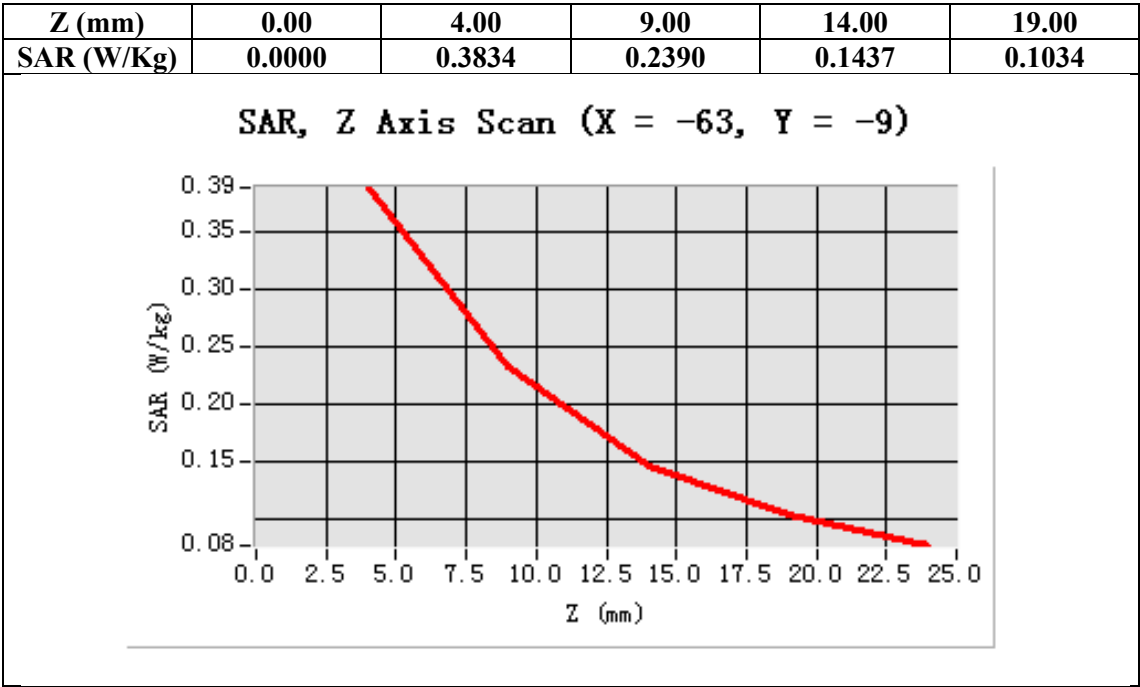

Test Laboratory: AGC Lab
1880MHz Mid-Tilt-Right <SIM 1>
DUT: CDMA Smart phone; Type: WOW 818

Date: Sep.09, 2013

Communication System: Generic; Communication System Band: 1880MHz; Duty Cycle: 1: 1; Conv.F=4.72
Frequency: 1880 MHz; Medium parameters used: $f=1880$ MHz; $\sigma=1.38$ mho/m; $\epsilon_r=39.87$; $\rho=1000$ kg/m³ ;
Phantom section: Right Section
Ambient temperature (°C): 21, Liquid temperature (°C): 21

- SATIMO Configuration:
Probe: EP165; Calibrated: 01/31/2013
- Sensor-Surface: 4mm (Mechanical Surface Detection)
 - Phantom: Flat Phantom; Type: Elliptical Phantom
 - Measurement SW: OpenSAR V4_02_01

Configuration/1880MHz Mid- Tilt-Right/Area Scan: Measurement grid: dx=8mm, dy=8mm
Configuration/1880MHz Mid- Tilt-Right/Zoom Scan: Measurement grid: dx=8mm, dy=8mm, dz=5mm;

Area Scan	sam_direct_droit2_surf8mm.txt
Zoom Scan	5x5x7,dx=8mm dy=8mm dz=5mm,Very fast
Phantom	Right head
Device Position	Tilt
Band	1880MHz
Channels	Middle
Signal	TDMA (Crest factor: 8.0)

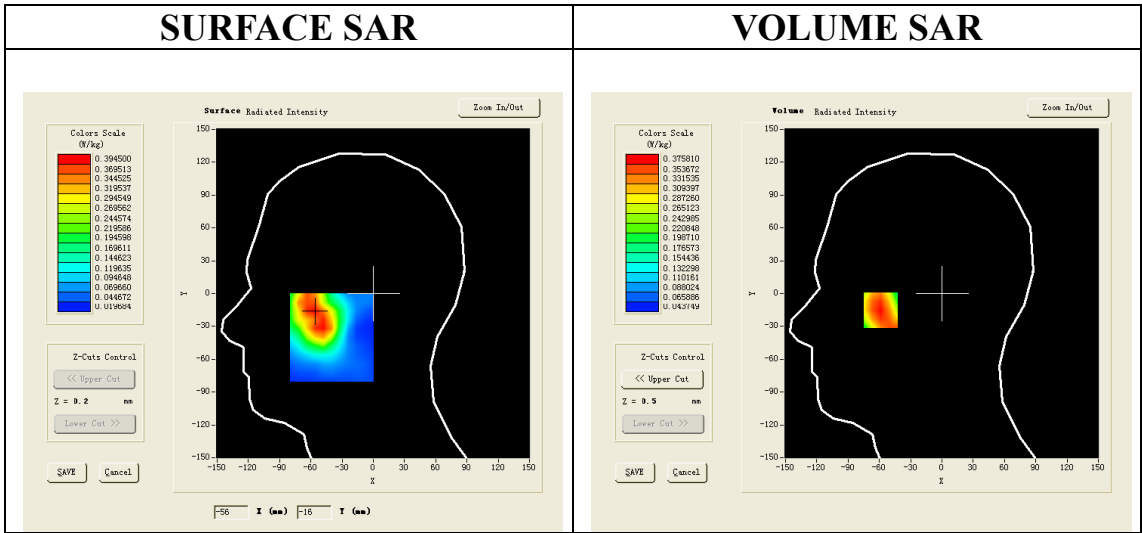

Maximum location: X=-59.00, Y=-14.00

SAR 10g (W/Kg)	0.246930
SAR 1g (W/Kg)	0.354085

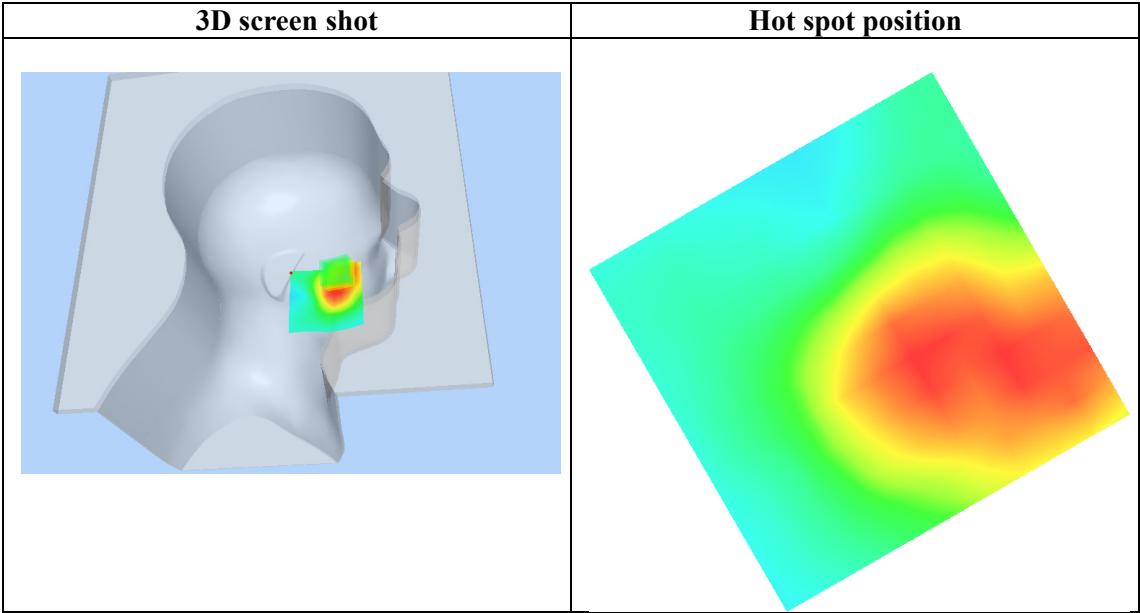
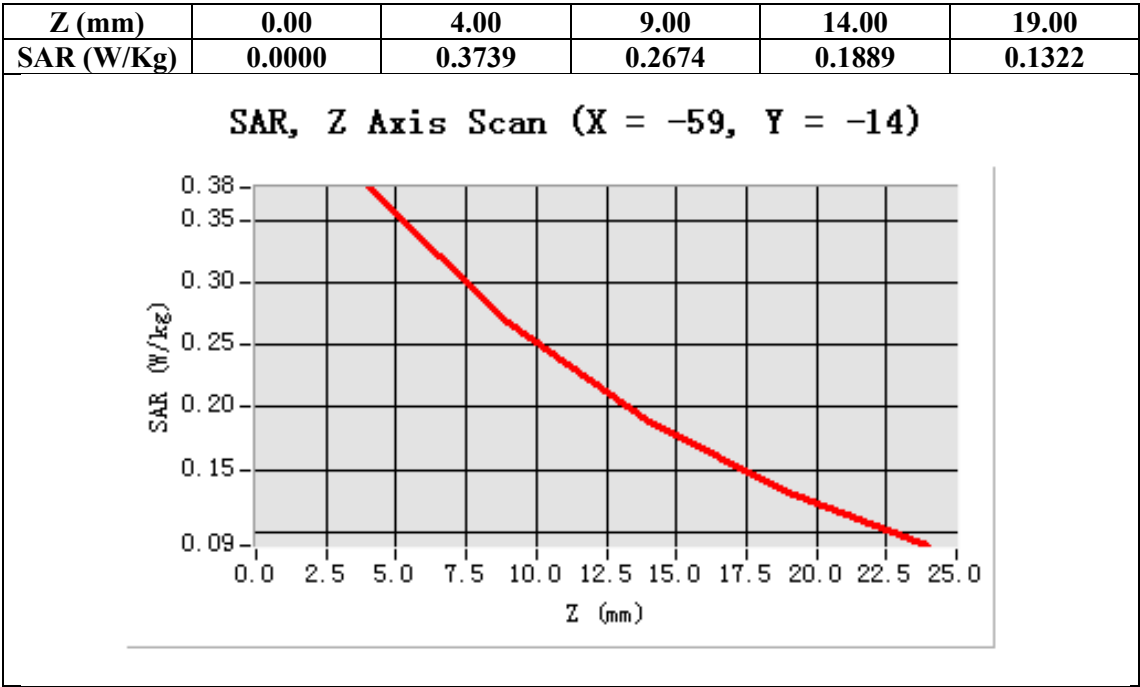

Test Laboratory: AGC Lab
1880MHz Mid-Touch-Left <SIM 1>
DUT: CDMA Smart phone; Type: WOW 818

Date: Sep.09, 2013

Communication System: Generic; Communication System Band: 1880MHz; Duty Cycle: 1: 1; Conv.F=4.72
Frequency: 1880 MHz; Medium parameters used: $f = 1880$ MHz; $\sigma = 1.38$ mho/m; $\epsilon_r = 39.87$; $\rho = 1000$ kg/m³ ;
Phantom section: Left Section
Ambient temperature (°C): 21, Liquid temperature (°C): 21

- SATIMO Configuration:
Probe: EP165; Calibrated: 01/31/2013
- Sensor-Surface: 4mm (Mechanical Surface Detection)
 - Phantom: Flat Phantom; Type: Elliptical Phantom
 - Measurement SW: OpenSAR V4_02_01

Configuration/1880MHz Mid- Touch-Left/Area Scan (6x8x1): Measurement grid: dx=8mm, dy=8mm
Configuration/1880MHz Mid- Touch-Left/Zoom Scan (5x5x7)/Cube 0: Measurement grid: dx=8mm, dy=8mm, dz=5mm

Area Scan	sam_direct_droit2_surf8mm.txt
ZoomScan	5x5x7,dx=8mm dy=8mm dz=5mm,Very fast
Phantom	Left head
Device Position	Cheek
Band	1880MHz
Channels	Middle
Signal	TDMA (Crest factor: 8.0)

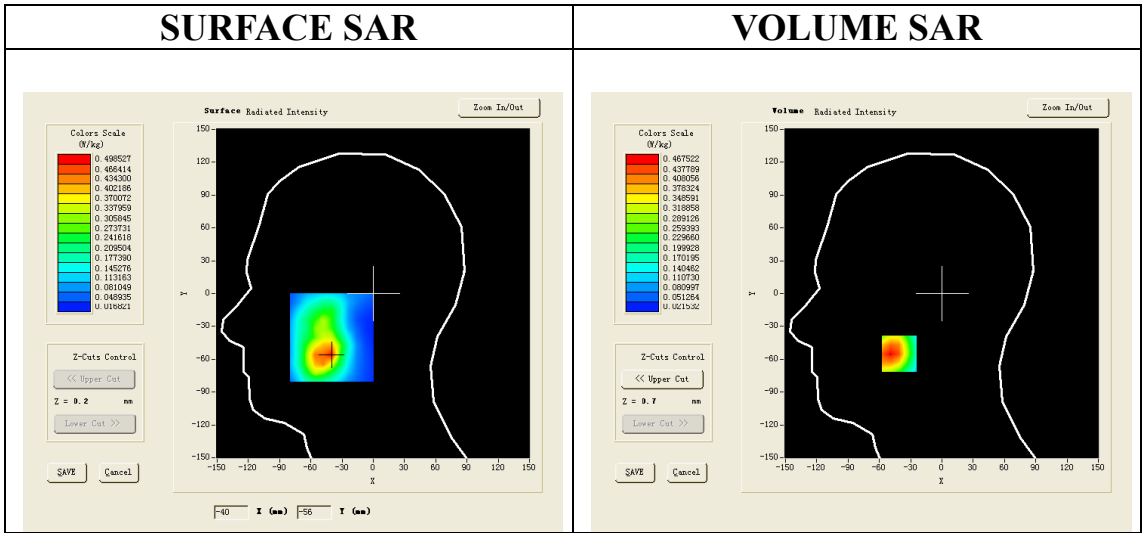

Maximum location: X=-41.00, Y=-55.00

SAR 10g (W/Kg)	0.271183
SAR 1g (W/Kg)	0.446917

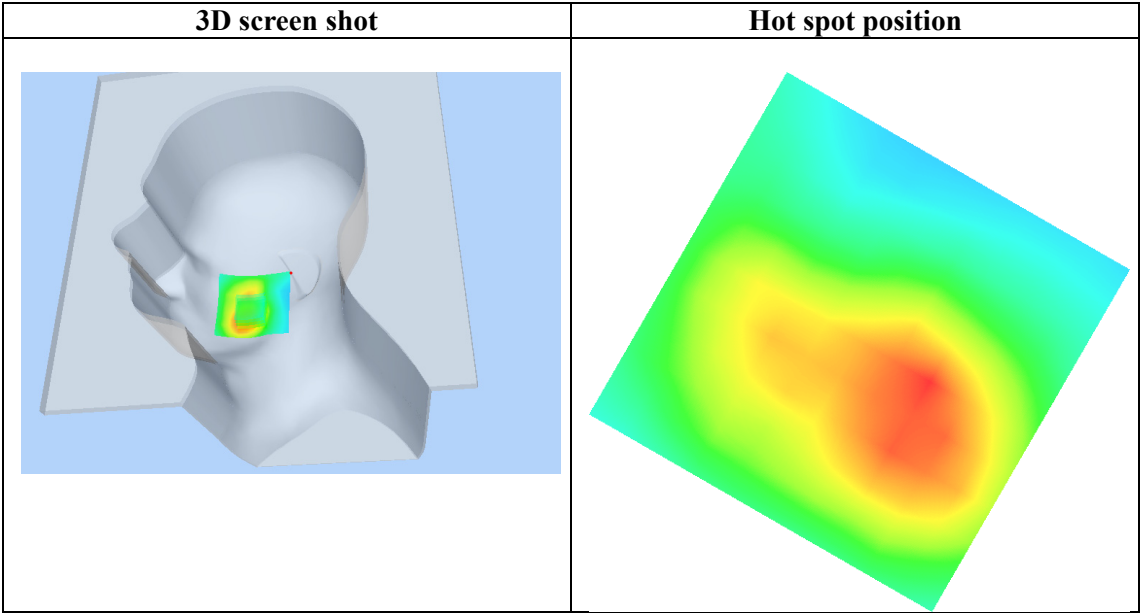
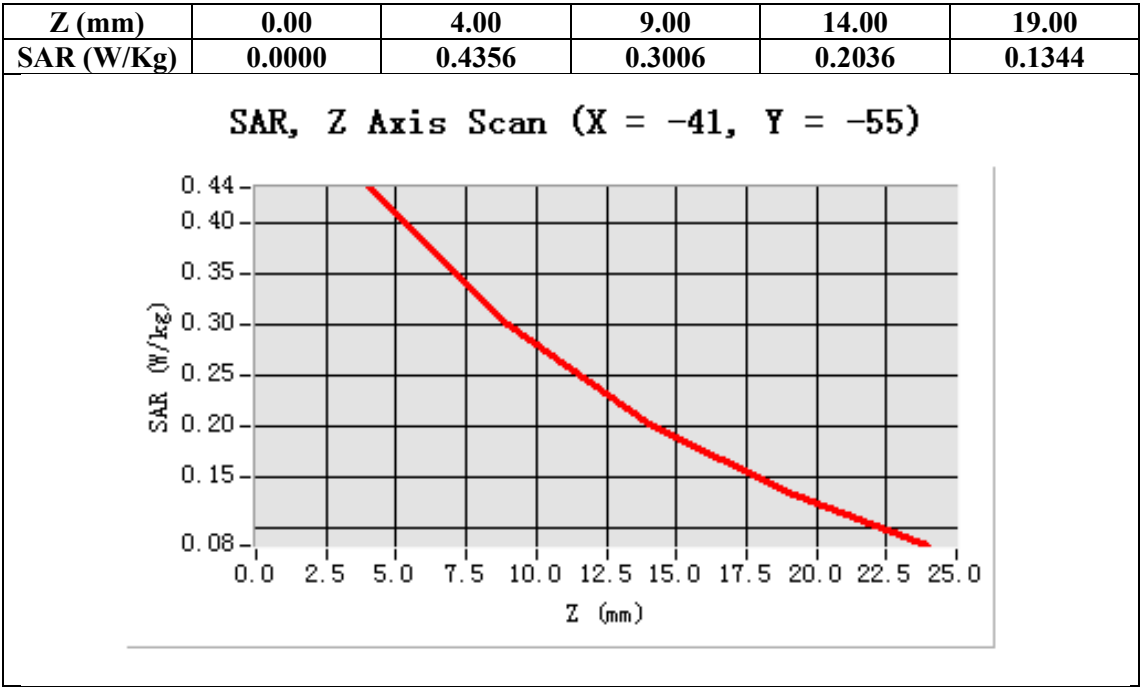

Test Laboratory: AGC Lab
1880MHz Mid-Body-Worn- Back (MS) <SIM 1>
DUT: CDMA Smart phone; Type: WOW 818

Date: Sep.09, 2013

Communication System: Generic; Communication System Band: 1880MHz; Duty Cycle: 1: 1; Conv.F=4.84
Frequency: 1880 MHz; Medium parameters used: $f = 1880$ MHz; $\sigma = \sigma_D$ mho/m; $\epsilon_r = 54.01$; $\rho = 1000$ kg/m³ ;
Phantom section: Flat Section
Ambient temperature (°C):21, Liquid temperature (°C):21

SATIMO Configuration:

Probe: EP165; Calibrated: 01/31/2013

- Sensor-Surface: 4mm (Mechanical Surface Detection)
- Phantom: Flat Phantom; Type: Elliptical Phantom
- Measurement SW: OpenSAR V4_02_01

Configuration/1880MHz Mid- Body- Back /Area Scan (6x8x1): Measurement grid: dx=8mm, dy=8mm
Configuration/1880MHz Mid- Body- Back /Zoom Scan (5x5x7)/Cube 0: Measurement grid: dx=8mm, dy=8mm, dz=5mm;

Area Scan	surf_sam_plan.txt
ZoomScan	5x5x7,dx=8mm dy=8mm dz=5mm,Very fast
Phantom	Validation plane
Device Position	Body Back
Band	1880MHz
Channels	Middle
Signal	TDMA (Crest factor: 8.0)

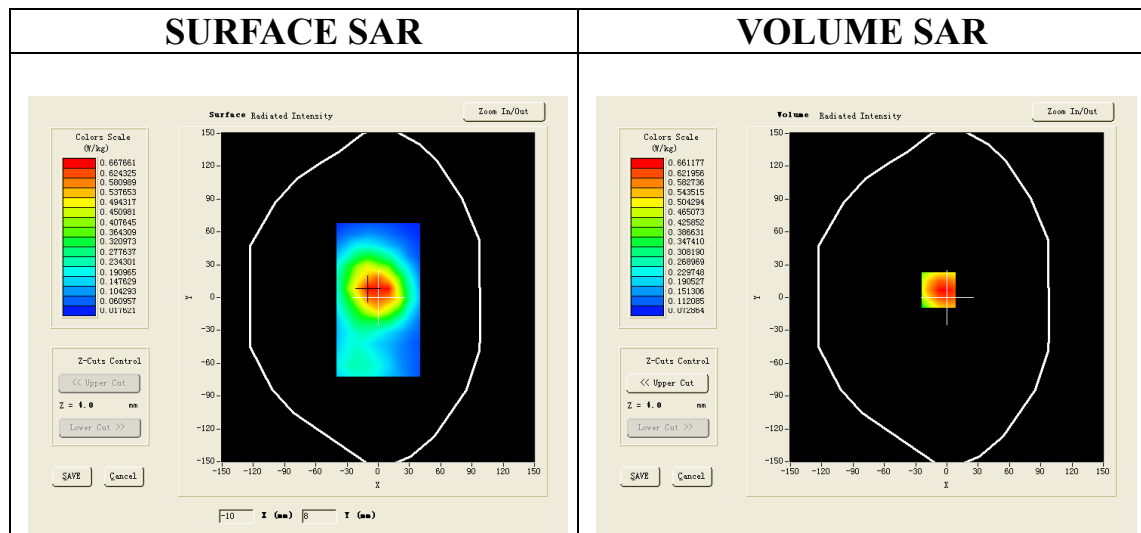

Maximum location: X=-8.00, Y=7.00

SAR 10g (W/Kg)	0.445820
SAR 1g (W/Kg)	0.693964

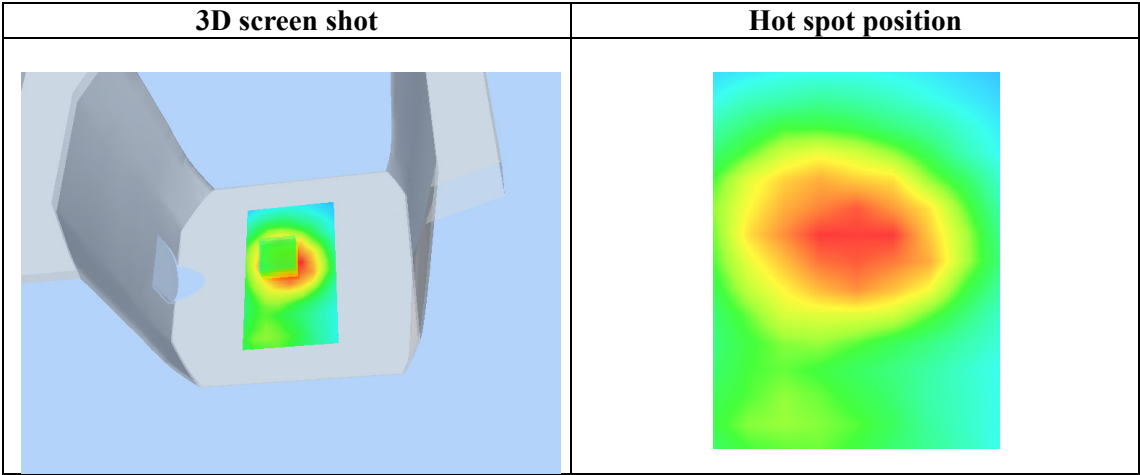
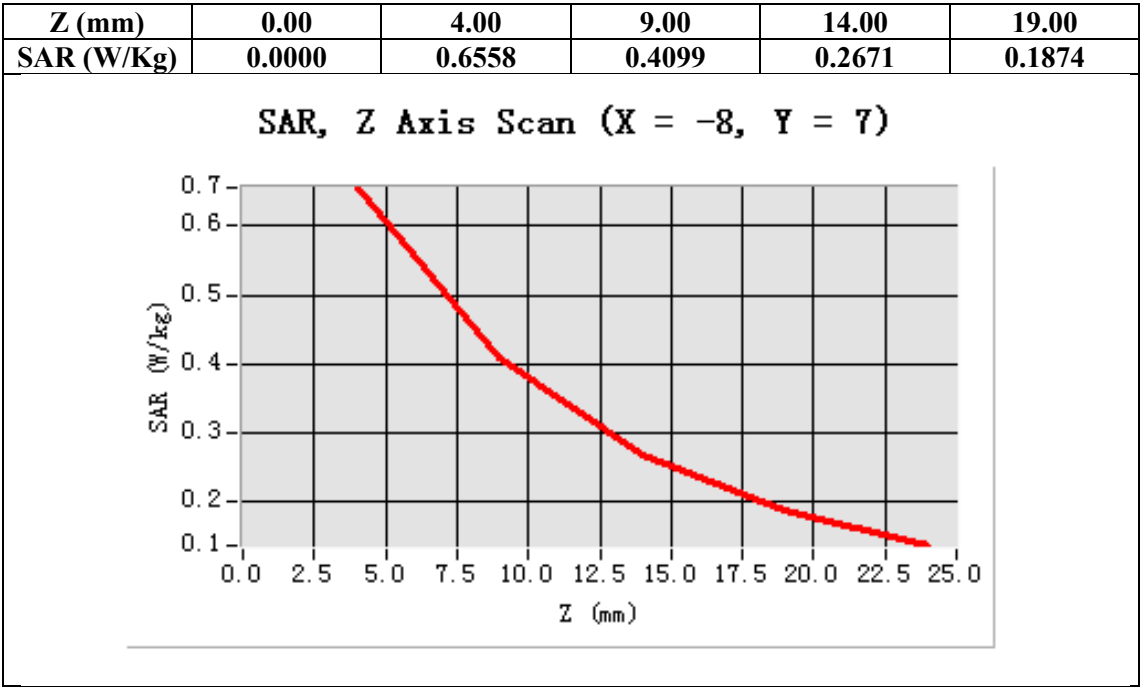

Test Laboratory: AGC Lab
1880MHz Mid-Body- Worn- Front (MS) <SIM 1>
DUT: CDMA Smart phone; Type: WOW 818

Date: Sep.09, 2013

Communication System: Generic; Communication System Band: 1880MHz; Duty Cycle: 1: 1; Conv.F=4.84
Frequency: 1880 MHz; Medium parameters used: $f = 835 \text{ MHz}$; $\sigma = \sigma_D \text{ mho/m}$; $\epsilon_r = 54.01$; $\rho = 1000 \text{ kg/m}^3$;
Phantom section: Flat Section
Ambient temperature ($^{\circ}\text{C}$):21, Liquid temperature ($^{\circ}\text{C}$):21

SATIMO Configuration:

- Probe: EP165; Calibrated: 01/31/2013
- Sensor-Surface: 4mm (Mechanical Surface Detection)
- Phantom: Flat Phantom; Type: Elliptical Phantom
- Measurement SW: OpenSAR V4_02_01

Configuration/1880MHz Mid- Body- Front /Area Scan (6x8x1): Measurement grid: dx=8mm, dy=8mm
Configuration/1880MHz Mid- Body- Front /Zoom Scan (5x5x7)/Cube 0: Measurement grid: dx=8mm, dy=8mm, dz=5mm;

Area Scan	surf_sam_plan.txt
ZoomScan	5x5x7,dx=8mm dy=8mm dz=5mm,Very fast
Phantom	Validation plane
Device Position	Body Front
Band	1880MHz
Channels	Middle
Signal	TDMA (Crest factor: 8.0)

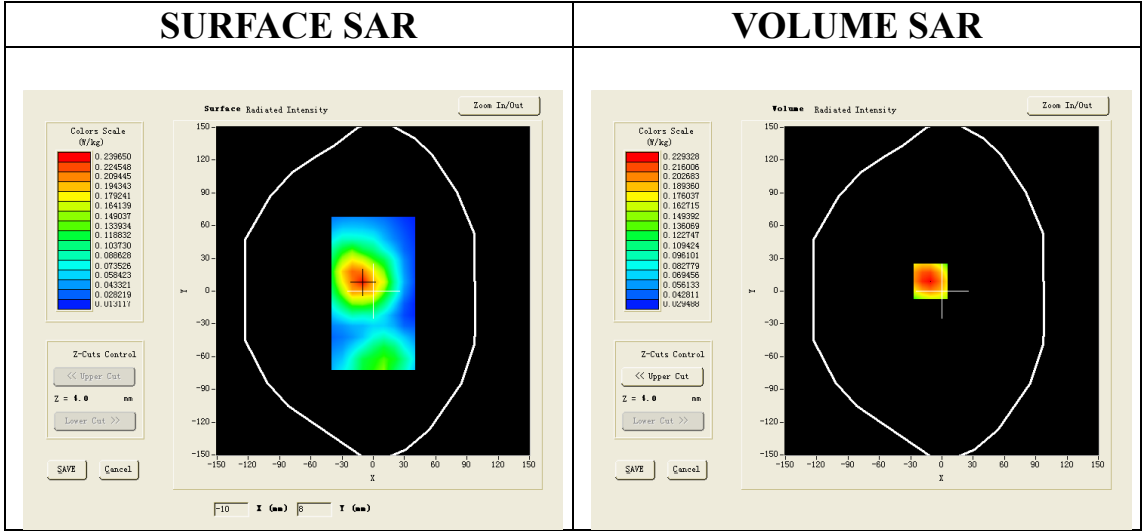

Maximum location: X=-11.00, Y=9.00

SAR 10g (W/Kg)	0.156785
SAR 1g (W/Kg)	0.233328

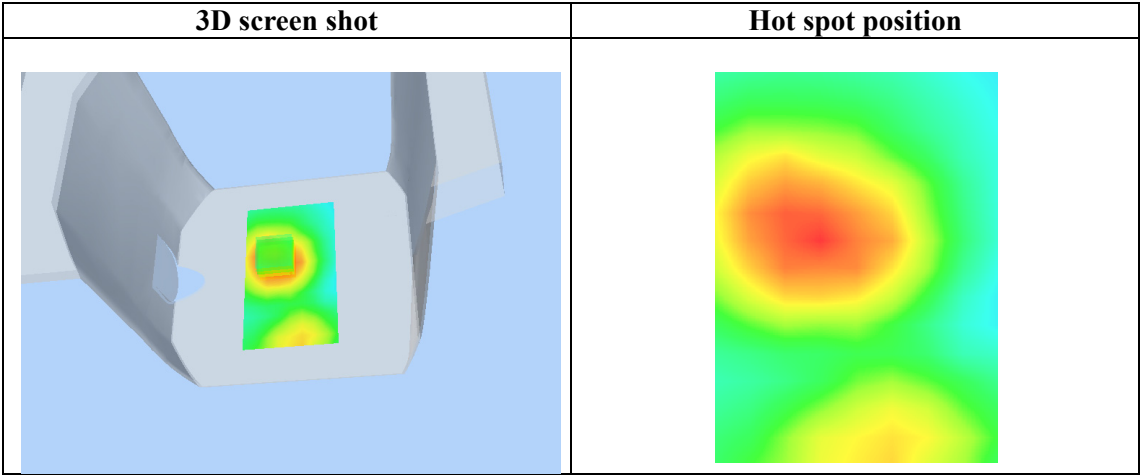
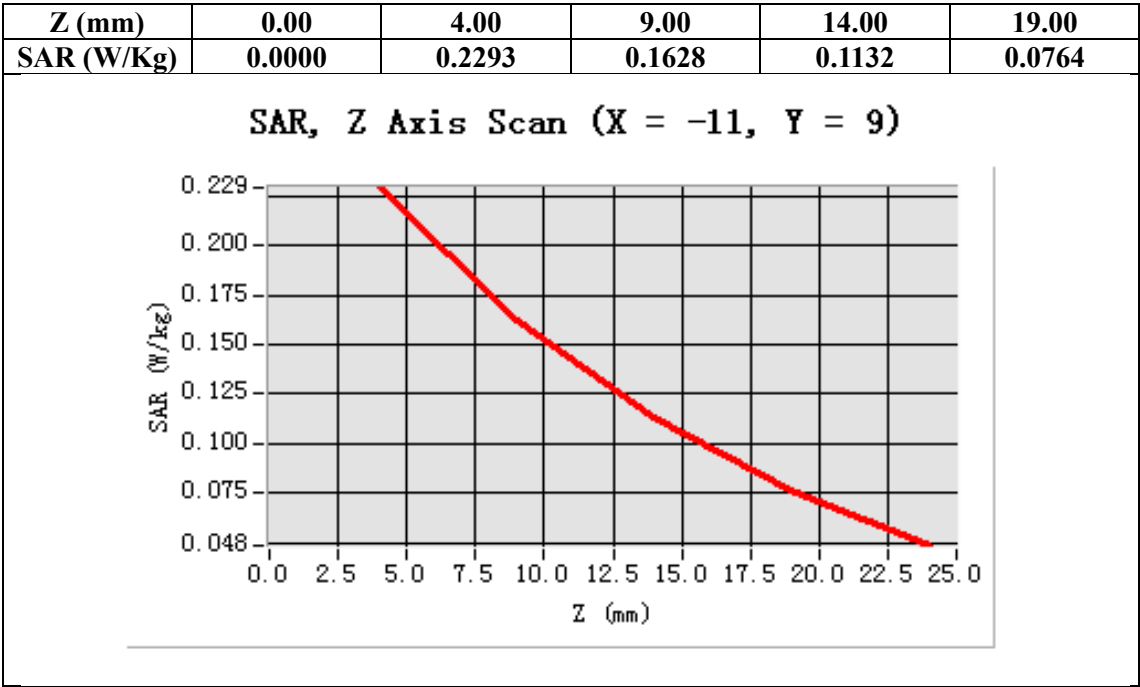

WIFI MODE

Test Laboratory: AGC Lab
 802.11b Mid-Touch-Left

Date: Sep.09, 2013

DUT: CDMA Smart phone; Type: WOW 818

Communication System: Wi-Fi; Communication System Band: 802.11b; Duty Cycle: 1:1; Conv.F=4.19;
 Frequency: 2437 MHz; Medium parameters used: $f = 2450$ MHz; $\sigma = 1.77$ mho/m; $\epsilon_r = 40.63$; $\rho = 1000$ kg/m³ ;
 Phantom section: Left Section
 Ambient temperature (°C): 21, Liquid temperature (°C): 21

SATIMO Configuration:

- Probe: EP165; Calibrated: 01/31/2013
- Sensor-Surface: 4mm (Mechanical Surface Detection)
- Phantom: Flat Phantom; Type: Elliptical Phantom
- Measurement SW: OpenSAR V4_02_01

Configuration/802.11b Mid- Touch-Left/Area Scan (6x8x1): Measurement grid: dx=8mm, dy=8mm
 Configuration/802.11b Mid- Touch-Left/Zoom Scan (5x5x7)/Cube 0: Measurement grid: dx=8mm, dy=8mm, dz=5mm

Area Scan	sam_direct_droit2_surf8mm.txt
ZoomScan	5x5x7,dx=8mm dy=8mm dz=5mm,Very fast
Phantom	Left head
Device Position	Cheek
Band	2450MHz
Channels	Middle
Signal	TDMA (Crest factor: 8.0)

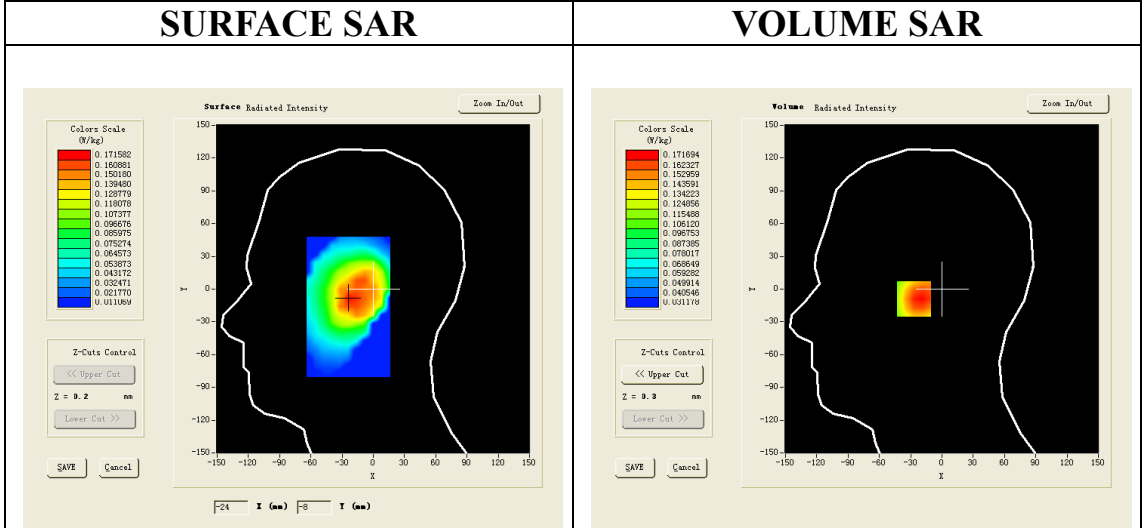

Maximum location: X=-23.00, Y=-9.00

SAR 10g (W/Kg)	0.122271
SAR 1g (W/Kg)	0.174416

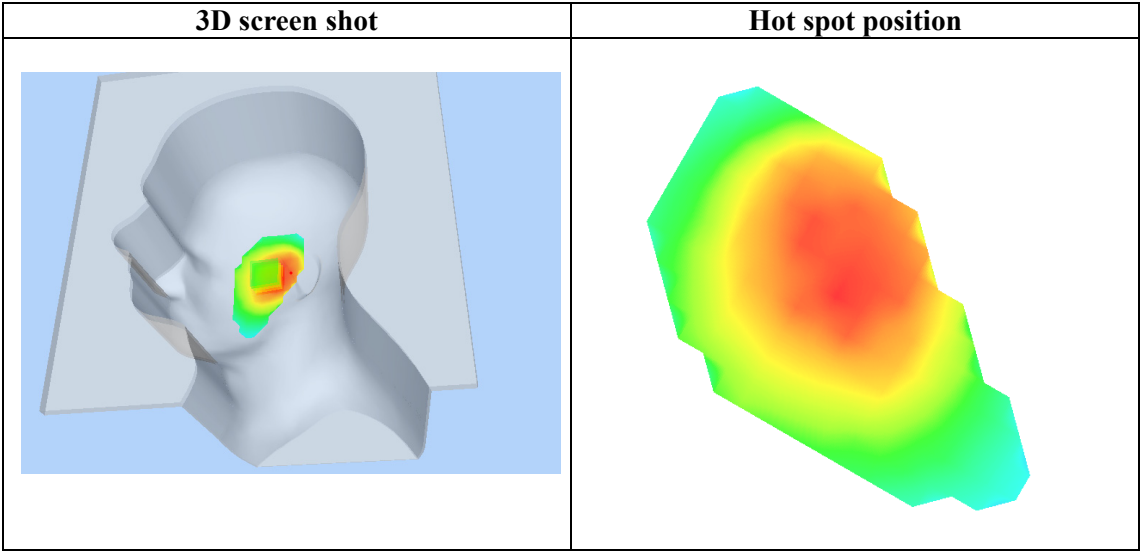
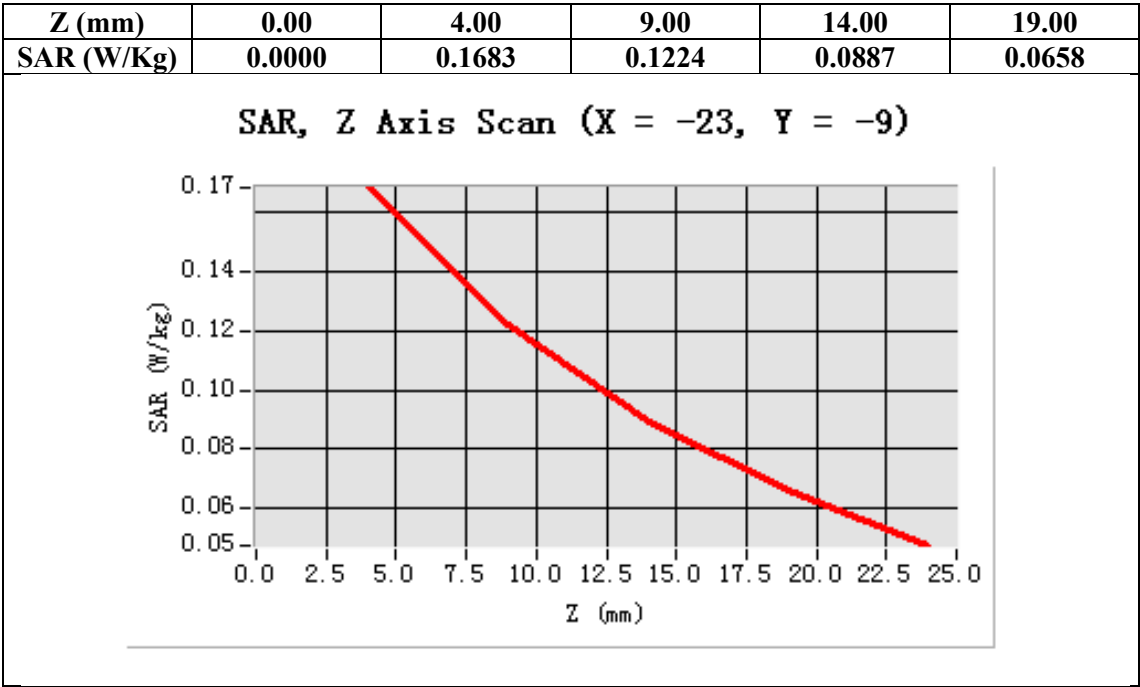

Test Laboratory: AGC Lab
802.11b Mid -Tilt-Left
DUT: CDMA Smart phone; Type: WOW 818

Date: Sep.09, 2013

Communication System: Wi-Fi; Communication System Band: 802.11b; Duty Cycle: 1:1; Conv.F=4.19;
Frequency: 2437 MHz; Medium parameters used: $f = 2450$ MHz; $\sigma = 1.77$ mho/m; $\epsilon_r = 40.63$; $\rho = 1000$ kg/m³ ;
Phantom section: Left Section
Ambient temperature (°C): 21, Liquid temperature (°C): 21

- SATIMO Configuration:
Probe: EP165; Calibrated: 01/31/2013
- Sensor-Surface: 4mm (Mechanical Surface Detection)
 - Phantom: Flat Phantom; Type: Elliptical Phantom
 - Measurement SW: OpenSAR V4_02_01

Configuration/802.11b Mid- Tilt-Left/Area Scan (6x8x1): Measurement grid: dx=8mm, dy=8mm
Configuration/802.11b Mid- Tilt-Left/Zoom Scan (5x5x7)/Cube 0: Measurement grid: dx=8mm, dy=8mm,dz=5mm;

Area Scan	sam_direct_droit2_surf8mm.txt
ZoomScan	5x5x7,dx=8mm dy=8mm dz=5mm,Very fast
Phantom	Left head
Device Position	Tilt
Band	2450MHz
Channels	Middle
Signal	TDMA (Crest factor: 8.0)

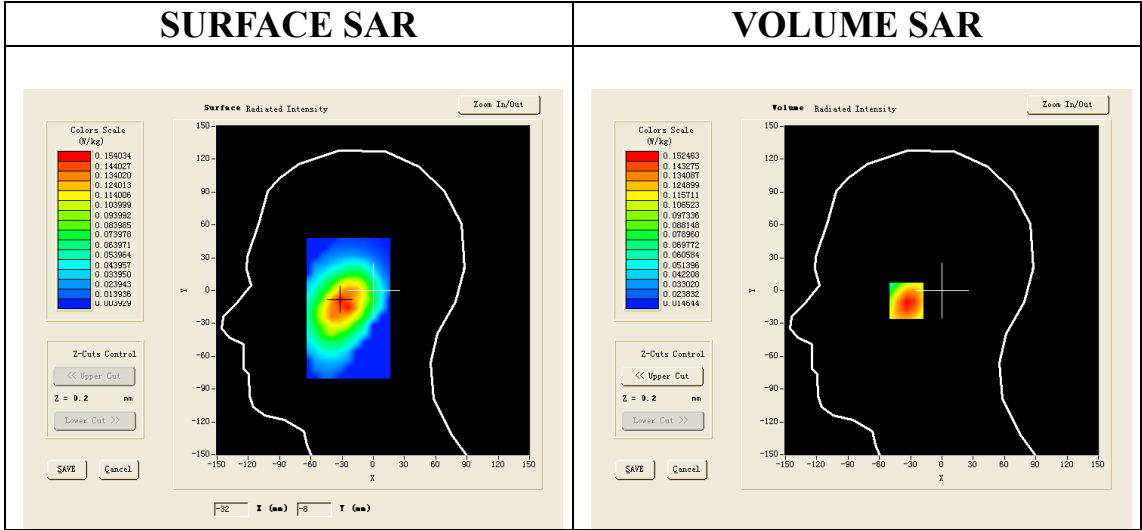

Maximum location: X=-32.00, Y=-9.00

SAR 10g (W/Kg)	0.096084
SAR 1g (W/Kg)	0.145714

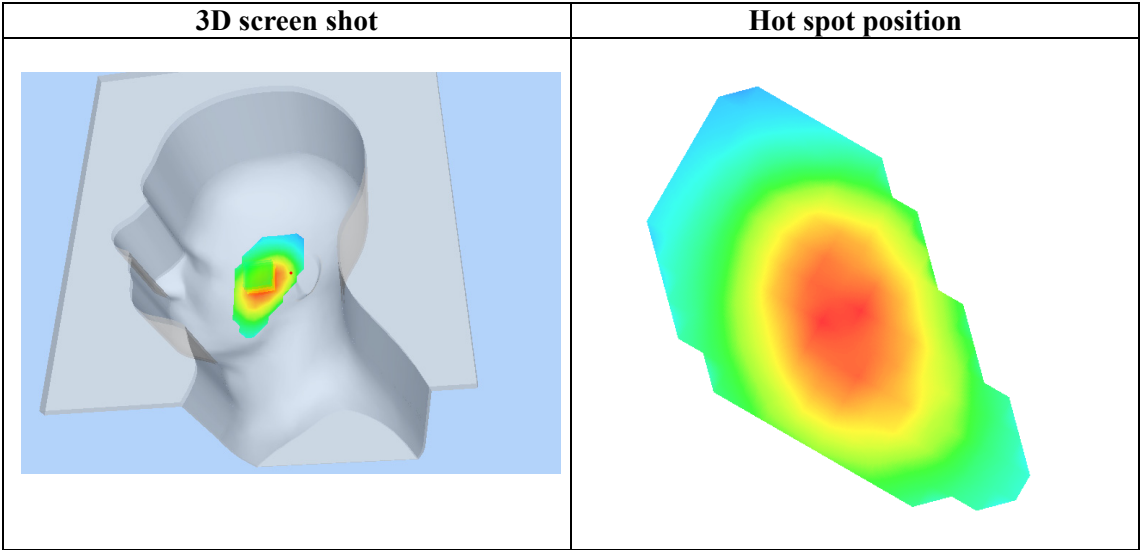
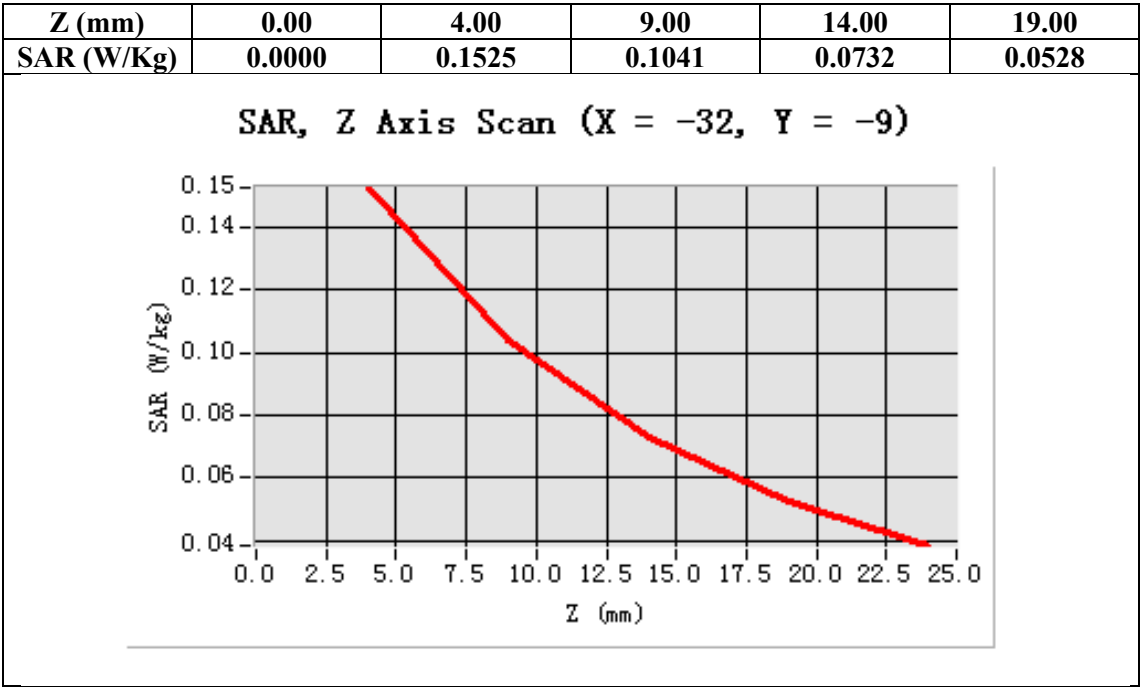

Test Laboratory: AGC Lab
 802.11b Mid- Touch-Right
DUT: CDMA Smart phone; Type: WOW 818

Date: Sep.09, 2013

Communication System: Wi-Fi; Communication System Band: 802.11b; Duty Cycle: 1:1; Conv.F=4.19;
 Frequency: 2437 MHz; Medium parameters used: $f = 2450$ MHz; $\sigma = 1.77$ mho/m; $\epsilon_r = 40.63$; $\rho = 1000$ kg/m³ ;
 Phantom section: Right Section
 Ambient temperature (°C): 21, Liquid temperature (°C): 21

- SATIMO Configuration:
 Probe: EP165; Calibrated: 01/31/2013
- Sensor-Surface: 4mm (Mechanical Surface Detection)
 - Phantom: Flat Phantom; Type: Elliptical Phantom
 - Measurement SW: OpenSAR V4_02_01

Configuration/802.11b Mid- Touch-Right /Area Scan: Measurement grid: dx=8mm, dy=8mm
Configuration/802.11b Mid- Touch-Right /Zoom Scan: Measurement grid: dx=8mm, dy=8mm, dz=5mm;

Area Scan	sam_direct_droit2_surf8mm.txt
ZoomScan	5x5x7,dx=8mm dy=8mm dz=5mm,Very fast
Phantom	Right head
Device Position	Cheek
Band	2450MHz
Channels	Middle
Signal	TDMA (Crest factor: 8.0)

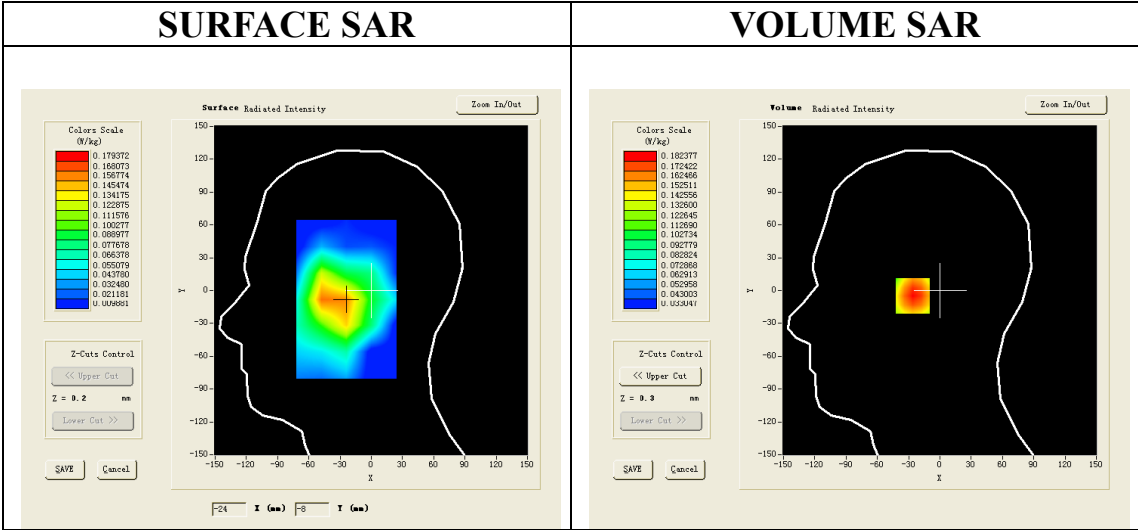

Maximum location: X=-23.00, Y=-5.00

SAR 10g (W/Kg)	0.111385
SAR 1g (W/Kg)	0.168345

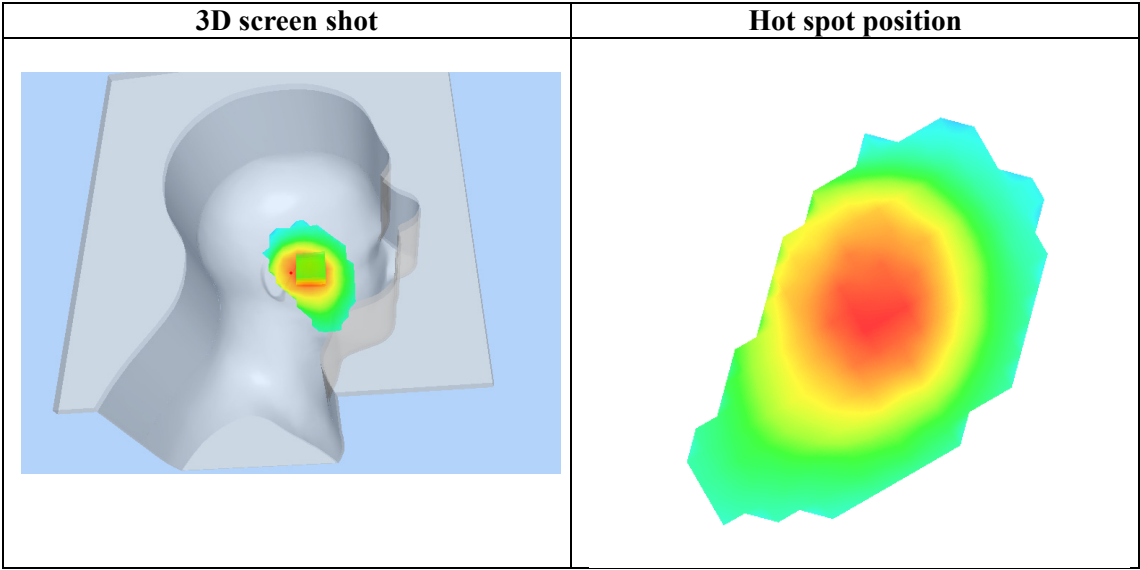
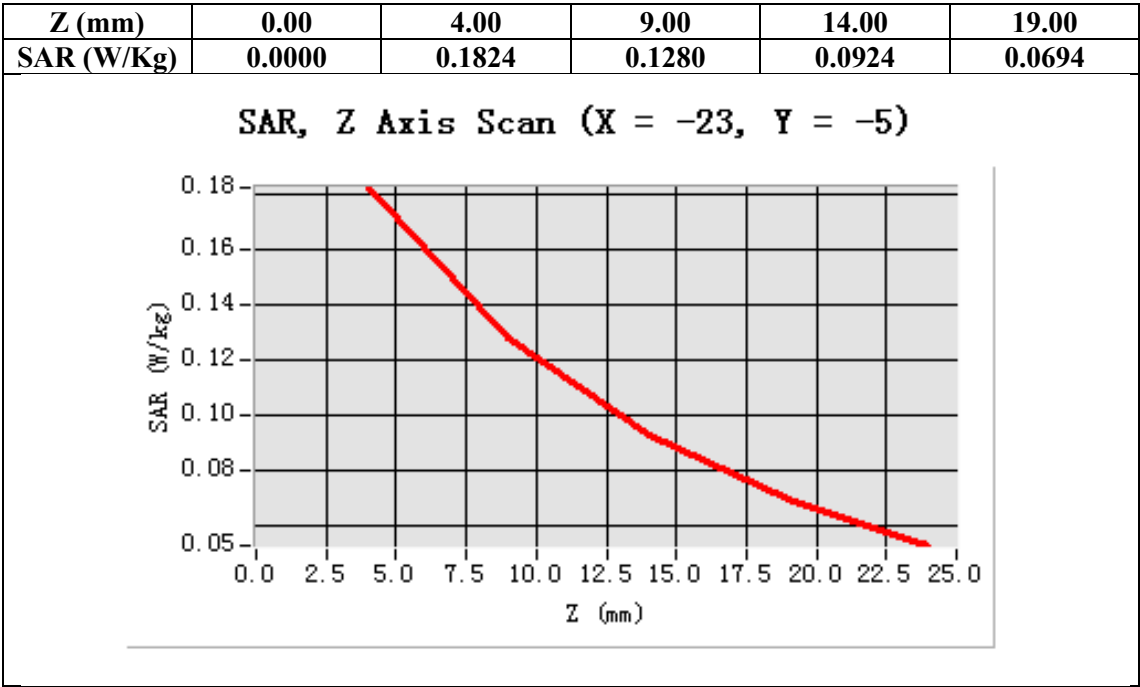

Test Laboratory: AGC Lab
802.11b Mid-Tilt-Right
DUT: CDMA Smart phone; Type: WOW 818

Date: Sep.09, 2013

Communication System: Wi-Fi; Communication System Band: 802.11b; Duty Cycle: 1:1; Conv.F=4.19;
Frequency: 2437 MHz; Medium parameters used: $f = 2450$ MHz; $\sigma = 1.77$ mho/m; $\epsilon_r = 40.63$; $\rho = 1000$ kg/m³ ;
Phantom section: Right Section
Ambient temperature (°C): 21, Liquid temperature (°C): 21

- SATIMO Configuration:
Probe: EP165; Calibrated: 01/31/2013
- Sensor-Surface: 4mm (Mechanical Surface Detection)
 - Phantom: Flat Phantom; Type: Elliptical Phantom
 - Measurement SW: OpenSAR V4_02_01

Configuration/802.11b Mid- Tilt-Right/Area Scan: Measurement grid: dx=8mm, dy=8mm

Configuration/802.11b Mid- Tilt-Right/Zoom Scan: Measurement grid: dx=8mm, dy=8mm, dz=5mm;

Area Scan	sam_direct_droit2_surf8mm.txt
Zoom Scan	5x5x7,dx=8mm dy=8mm dz=5mm,Very fast
Phantom	Right head
Device Position	Tilt
Band	2450MHz
Channels	Middle
Signal	TDMA (Crest factor: 8.0)

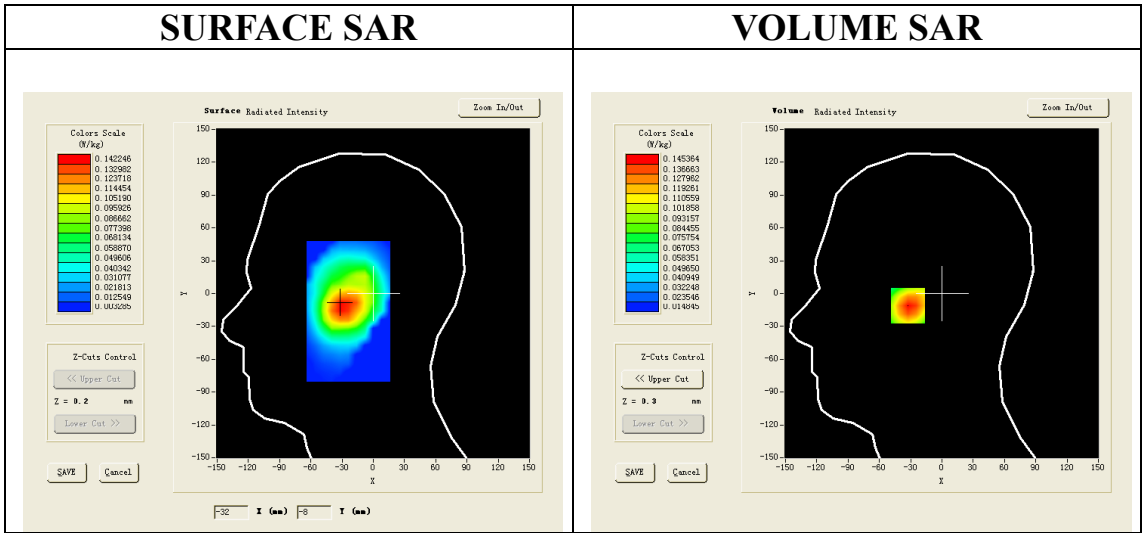

Maximum location: X=-30.00, Y=-11.00

SAR 10g (W/Kg)	0.087245
SAR 1g (W/Kg)	0.133284

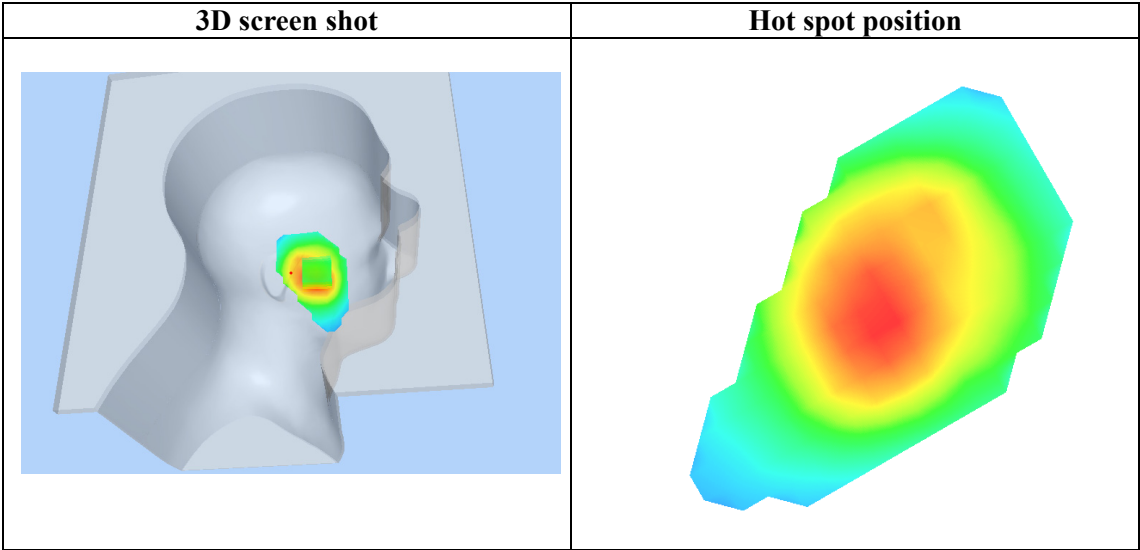
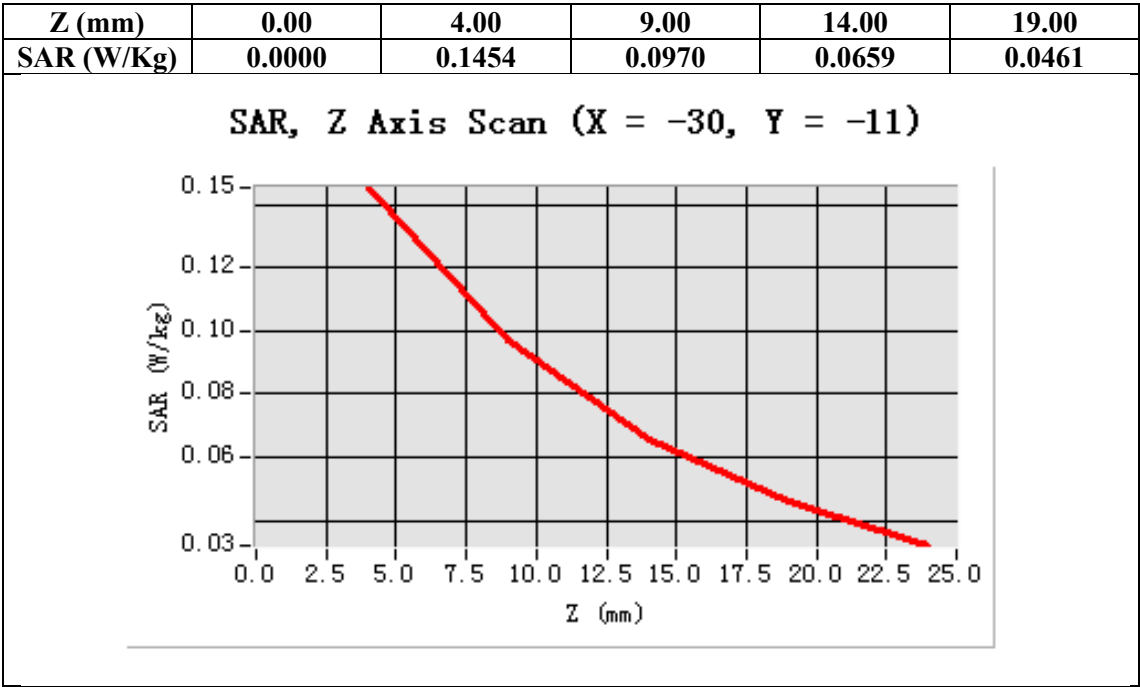

Test Laboratory: AGC Lab
802.11b Mid-Body-Worn- Back (MS)
DUT: CDMA Smart phone; Type: WOW 818

Date: Sep.09, 2013

Communication System: Wi-Fi; Communication System Band: 802.11b; Duty Cycle: 1:1; Conv.F=4.32;
Frequency: 2437 MHz; Medium parameters used: $f = 2450$ MHz; $\sigma = 1.92$ mho/m; $\epsilon_r = 53.16$; $\rho = 1000$ kg/m³ ;
Phantom section: Flat Section
Ambient temperature (°C):21, Liquid temperature (°C):21

- SATIMO Configuration:
Probe: EP165; Calibrated: 01/31/2013
- Sensor-Surface: 4mm (Mechanical Surface Detection)
 - Phantom: Flat Phantom; Type: Elliptical Phantom
 - Measurement SW: OpenSAR V4_02_01

Configuration/802.11b Mid- Body- Back /Area Scan (6x8x1): Measurement grid: dx=8mm, dy=8mm
Configuration/802.11b Mid- Body- Back /Zoom Scan (5x5x7)/Cube 0: Measurement grid: dx=8mm, dy=8mm, dz=5mm;

Area Scan	surf_sam_plan.txt
ZoomScan	5x5x7,dx=8mm dy=8mm dz=5mm,Very fast
Phantom	Validation plane
Device Position	Body Back
Band	2450MHz
Channels	Middle
Signal	TDMA (Crest factor: 8.0)

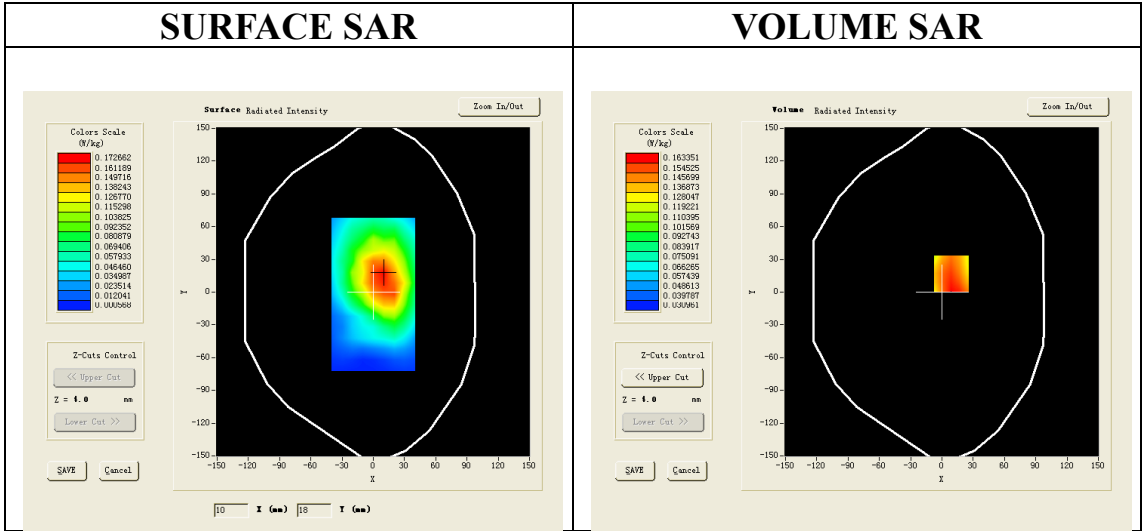

Maximum location: X=9.00, Y=17.00

SAR 10g (W/Kg)	0.106218
SAR 1g (W/Kg)	0.155217

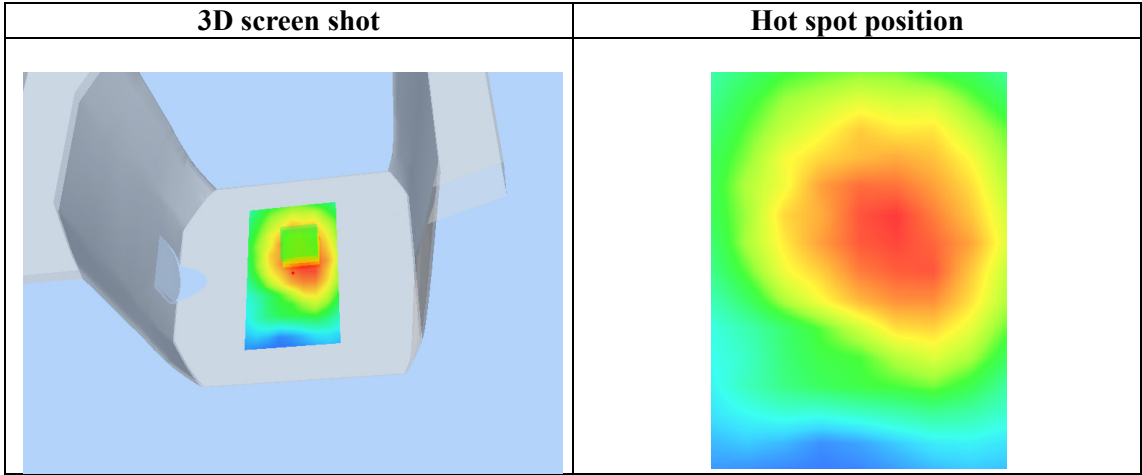
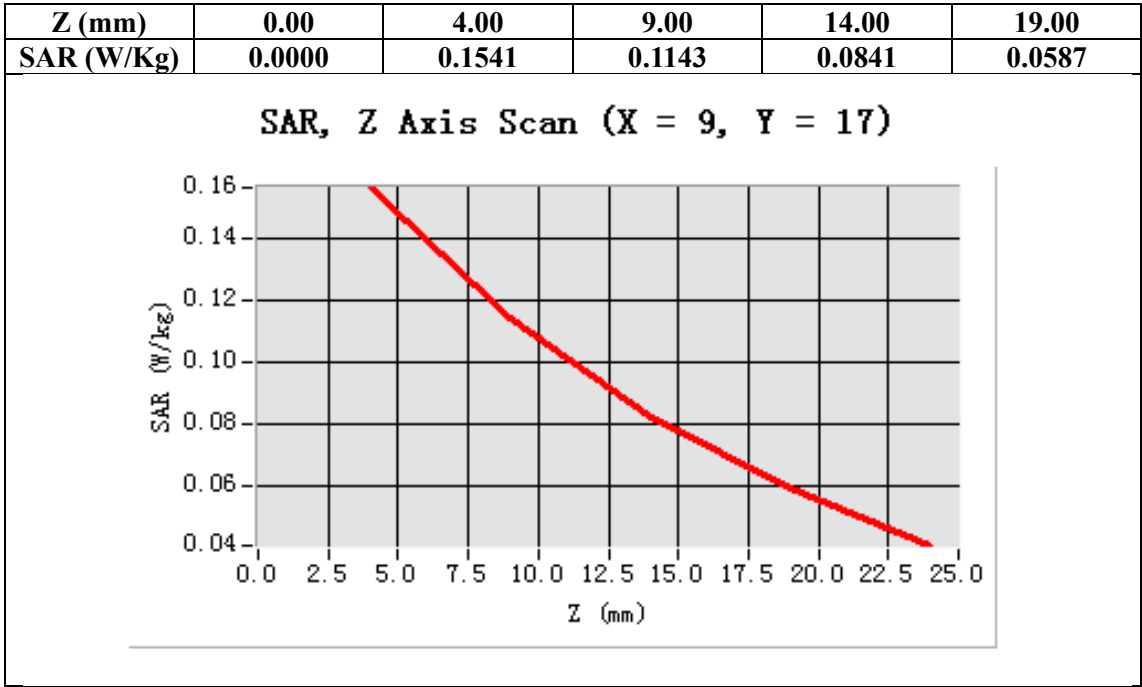

Test Laboratory: AGC Lab
802.11b Mid-Body -Front (MS)
DUT: CDMA Smart phone; Type: WOW 818

Date: Sep.09, 2013

Communication System: Wi-Fi; Communication System Band: 802.11b; Duty Cycle: 1:1; Conv.F=4.32;
Frequency: 2437 MHz; Medium parameters used: $f = 2450$ MHz; $\sigma = 1.92$ mho/m; $\epsilon_r = 53.16$; $\rho = 1000$ kg/m³ ;
Phantom section: Flat Section
Ambient temperature (°C):21, Liquid temperature (°C):21

- SATIMO Configuration:
Probe: EP165; Calibrated: 01/31/2013
- Sensor-Surface: 4mm (Mechanical Surface Detection)
 - Phantom: Flat Phantom; Type: Elliptical Phantom
 - Measurement SW: OpenSAR V4_02_01

Configuration/802.11b Mid-Body- Front /Area Scan: Measurement grid: dx=8mm, dy=8mm
Configuration/802.11b Mid-Body- Front /Zoom Scan: Measurement grid: dx=8mm, dy=8mm, dz=5mm;

Area Scan	surf_sam_plan.txt
ZoomScan	5x5x7,dx=8mm dy=8mm dz=5mm,Very fast
Phantom	Validation plane
Device Position	Body Front
Band	2450MHz
Channels	Middle
Signal	TDMA (Crest factor: 8.0)

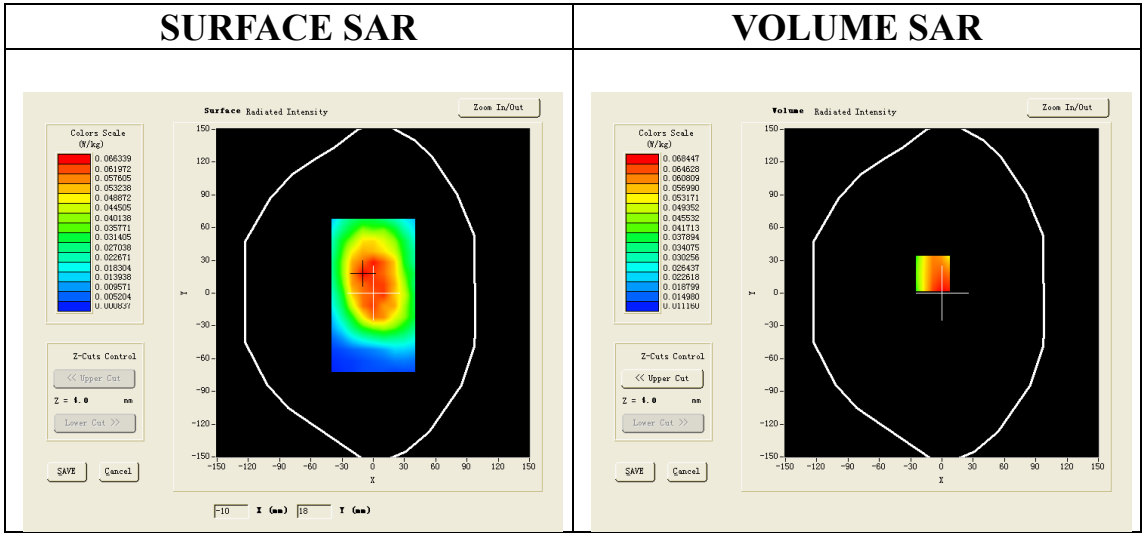

Maximum location: X=-9.00, Y=18.00

SAR 10g (W/Kg)	0.048827
SAR 1g (W/Kg)	0.063028

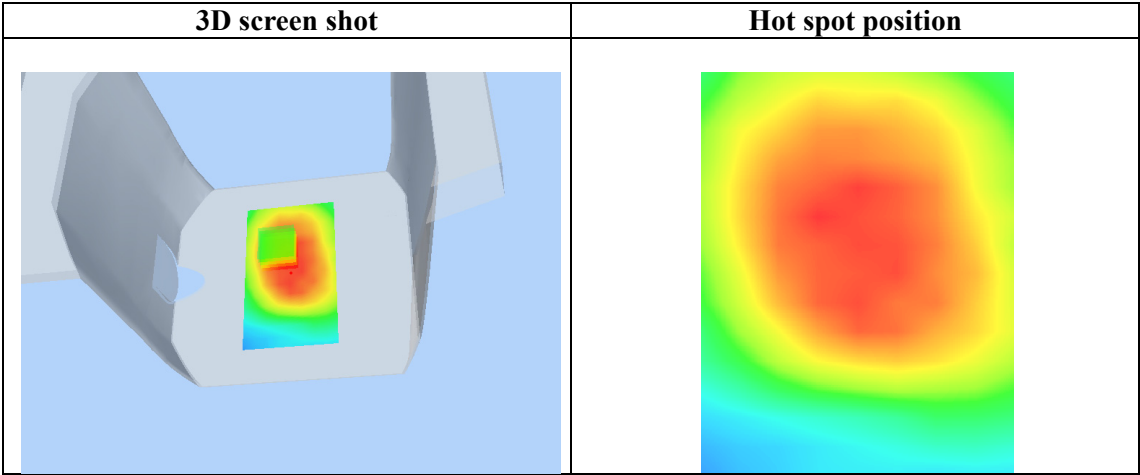
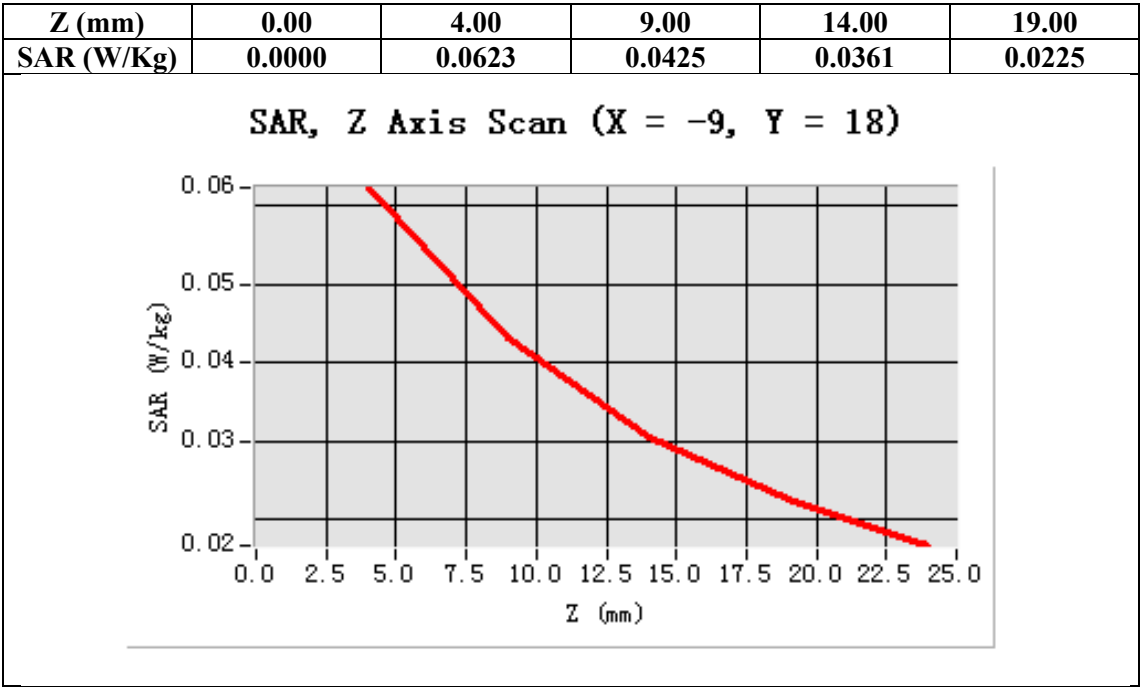

HOTSPOT MODE

Test Laboratory: AGC Lab
Hotspot Mid-Touch-Left

Date: Sep.09, 2013

DUT: CDMA Smart phone; Type: WOW 818

Communication System: Wi-Fi; Communication System Band: Hotspot; Duty Cycle: 1:1; Conv.F=4.19;
Frequency: 2437 MHz; Medium parameters used: $f = 2450$ MHz; $\sigma = 1.77$ mho/m; $\epsilon_r = 40.63$; $\rho = 1000$ kg/m³ ;
Phantom section: Left Section
Ambient temperature (°C): 21, Liquid temperature (°C): 21

SATIMO Configuration:

Probe: EP165; Calibrated: 01/31/2013

- Sensor-Surface: 4mm (Mechanical Surface Detection)
- Phantom: Flat Phantom; Type: Elliptical Phantom
- Measurement SW: OpenSAR V4_02_01

Configuration/Hotspot Mid- Touch-Left/Area Scan (6x8x1): Measurement grid: dx=8mm, dy=8mm
Configuration/Hotspot Mid- Touch-Left/Zoom Scan (5x5x7)/Cube 0: Measurement grid: dx=8mm, dy=8mm, dz=5mm

Area Scan	sam_direct_droit2_surf8mm.txt
ZoomScan	5x5x7,dx=8mm dy=8mm dz=5mm,Very fast
Phantom	Left head
Device Position	Cheek
Band	2450MHz
Channels	Middle
Signal	TDMA (Crest factor: 8.0)

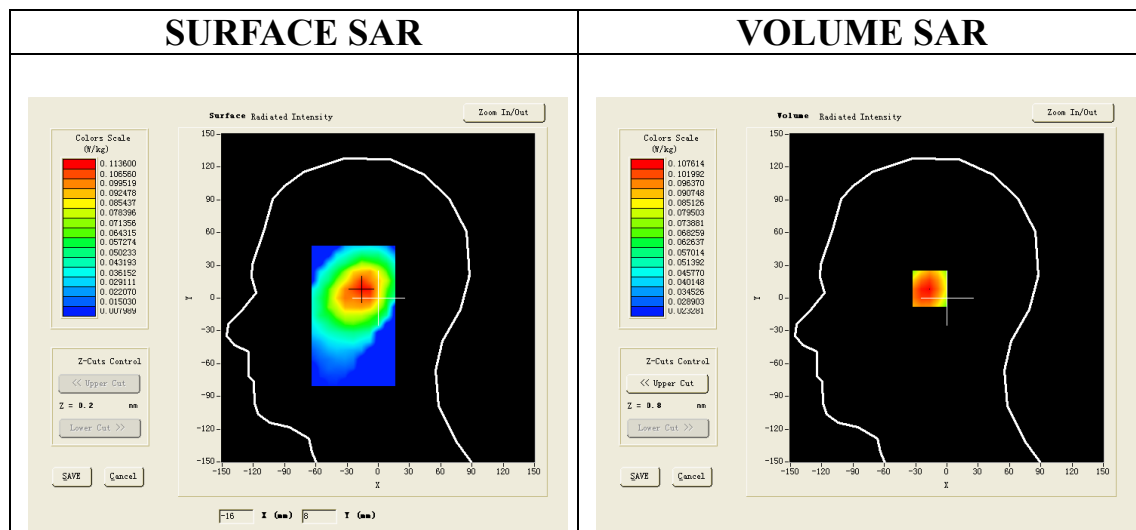

Maximum location: X=-14.00, Y=9.00

SAR 10g (W/Kg)	0.074218
SAR 1g (W/Kg)	0.103675

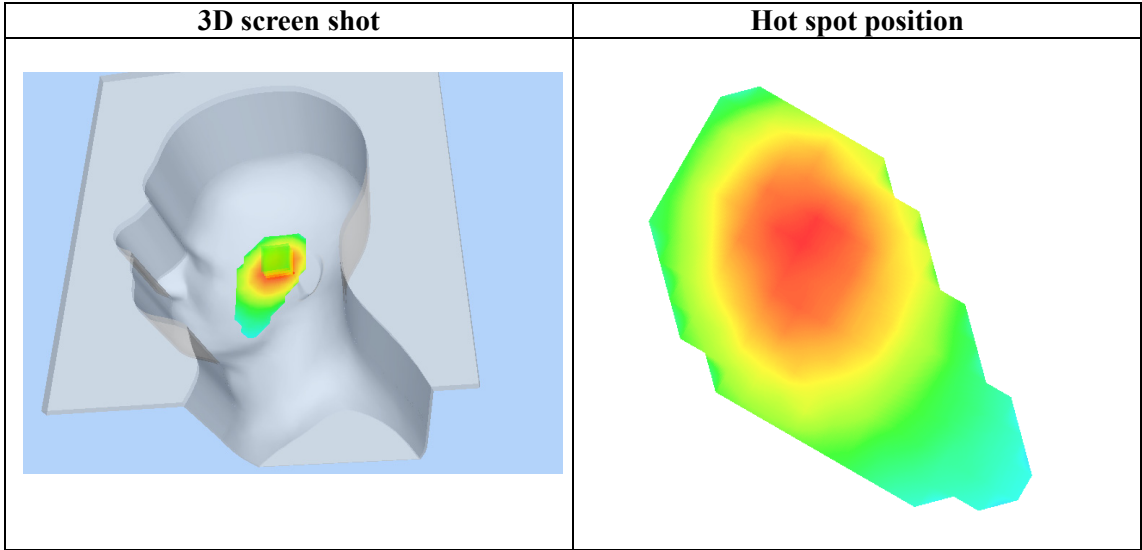
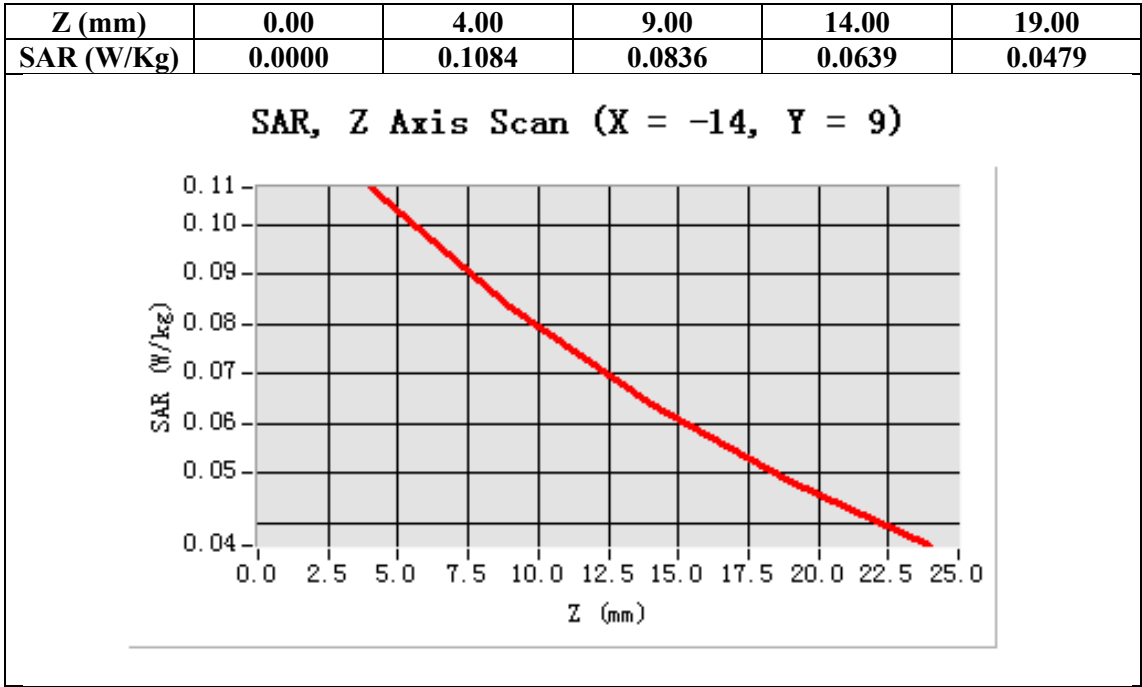

Test Laboratory: AGC Lab
Hotspot Mid -Tilt-Left
DUT: CDMA Smart phone; Type: WOW 818

Date: Sep.09, 2013

Communication System: Wi-Fi; Communication System Band: Hotspot; Duty Cycle: 1:1; Conv.F=4.19;
Frequency: 2437 MHz; Medium parameters used: $f = 2450$ MHz; $\sigma = 1.77$ mho/m; $\epsilon_r = 40.63$; $\rho = 1000$ kg/m³ ;
Phantom section: Left Section
Ambient temperature (°C): 21, Liquid temperature (°C): 21

SATIMO Configuration:

Probe: EP165; Calibrated: 01/31/2013

- Sensor-Surface: 4mm (Mechanical Surface Detection)
- Phantom: Flat Phantom; Type: Elliptical Phantom
- Measurement SW: OpenSAR V4_02_01

Configuration/Hotspot Mid- Tilt-Left/Area Scan (6x8x1): Measurement grid: dx=8mm, dy=8mm
Configuration/Hotspot Mid- Tilt-Left/Zoom Scan (5x5x7)/Cube 0: Measurement grid: dx=8mm, dy=8mm,dz=5mm;

Area Scan	sam_direct_droit2_surf8mm.txt
ZoomScan	5x5x7,dx=8mm dy=8mm dz=5mm,Very fast
Phantom	Left head
Device Position	Tilt
Band	2450MHz
Channels	Middle
Signal	TDMA (Crest factor: 8.0)

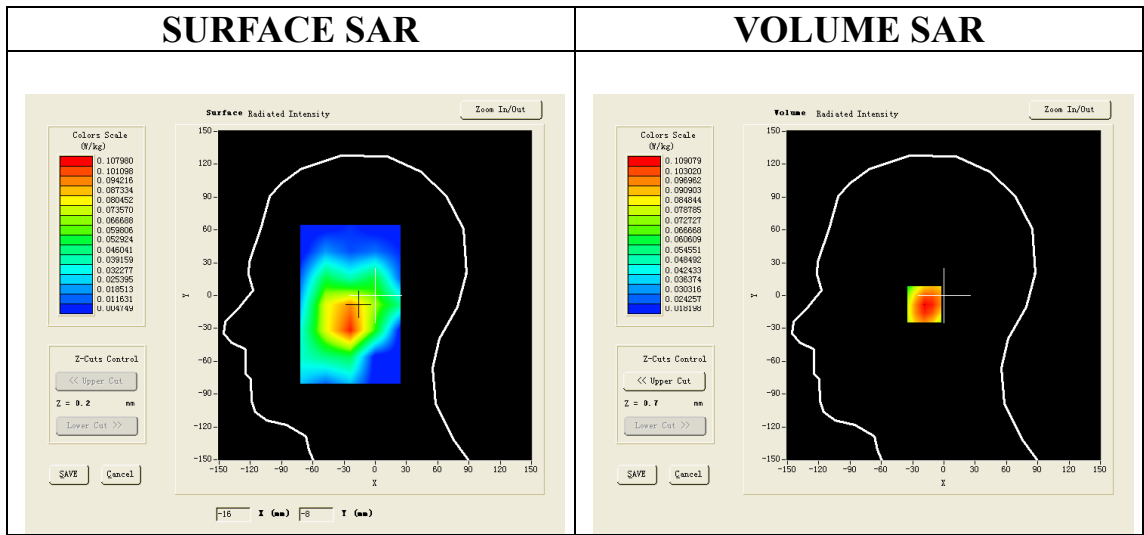

Maximum location: X=-15.00, Y=-8.00

SAR 10g (W/Kg)	0.075217
SAR 1g (W/Kg)	0.104238

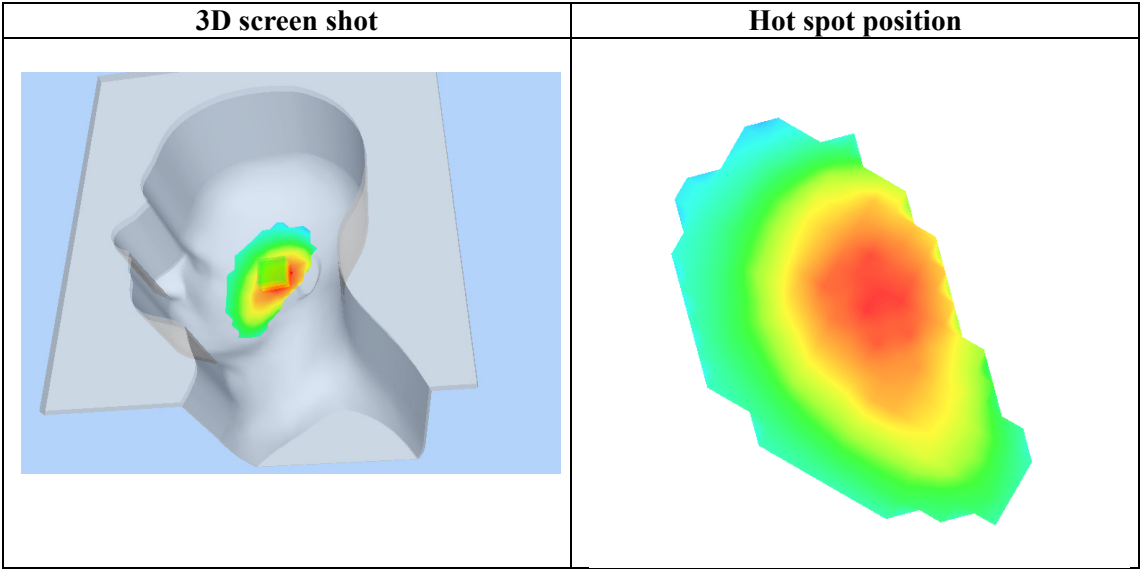
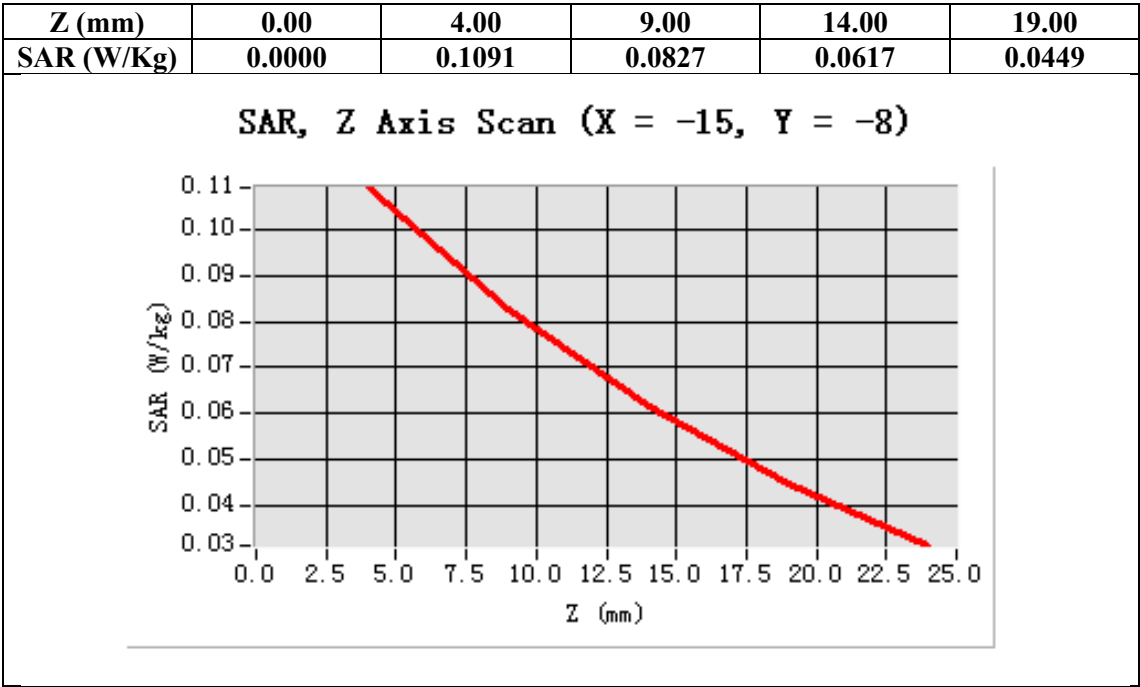

Test Laboratory: AGC Lab
Hotspot Mid- Touch-Right
DUT: CDMA Smart phone; Type: WOW 818

Date: Sep.09, 2013

Communication System: Wi-Fi; Communication System Band: Hotspot; Duty Cycle: 1:1; Conv.F=4.19;
Frequency: 2437 MHz; Medium parameters used: $f = 2450$ MHz; $\sigma = 1.77$ mho/m; $\epsilon_r = 40.63$; $\rho = 1000$ kg/m³ ;
Phantom section: Right Section
Ambient temperature (°C): 21, Liquid temperature (°C): 21

- SATIMO Configuration:
Probe: EP165; Calibrated: 01/31/2013
- Sensor-Surface: 4mm (Mechanical Surface Detection)
 - Phantom: Flat Phantom; Type: Elliptical Phantom
 - Measurement SW: OpenSAR V4_02_01

Configuration/Hotspot Mid- Touch-Right /Area Scan: Measurement grid: dx=8mm, dy=8mm
Configuration/Hotspot Mid- Touch-Right /Zoom Scan: Measurement grid: dx=8mm, dy=8mm, dz=5mm;

Area Scan	sam_direct_droit2_surf8mm.txt
ZoomScan	5x5x7,dx=8mm dy=8mm dz=5mm,Very fast
Phantom	Right head
Device Position	Cheek
Band	2450MHz
Channels	Middle
Signal	TDMA (Crest factor: 8.0)

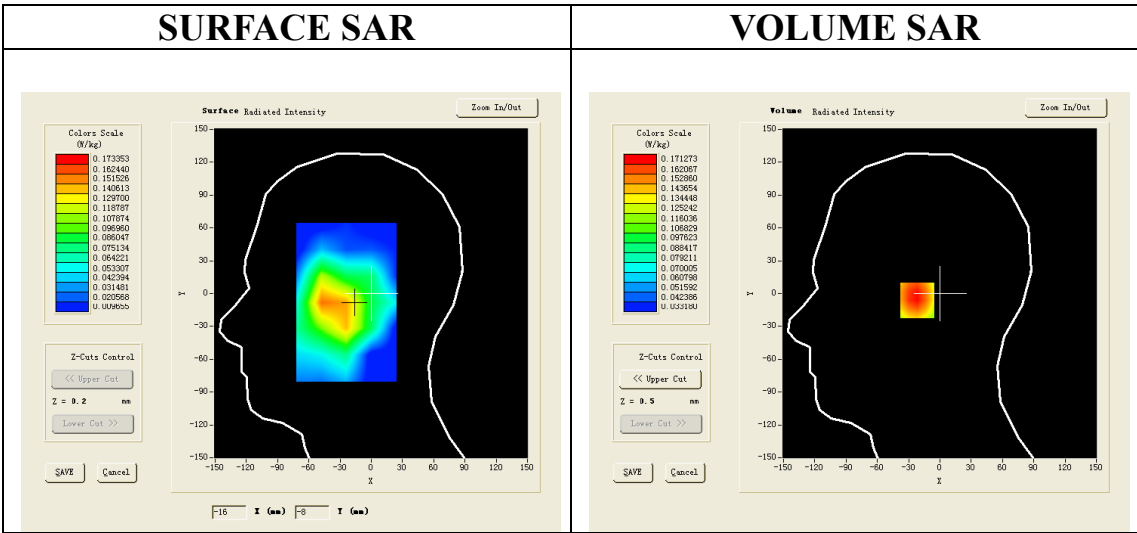

Maximum location: X=-18.00, Y=-6.00

SAR 10g (W/Kg)	0.117516
SAR 1g (W/Kg)	0.163862

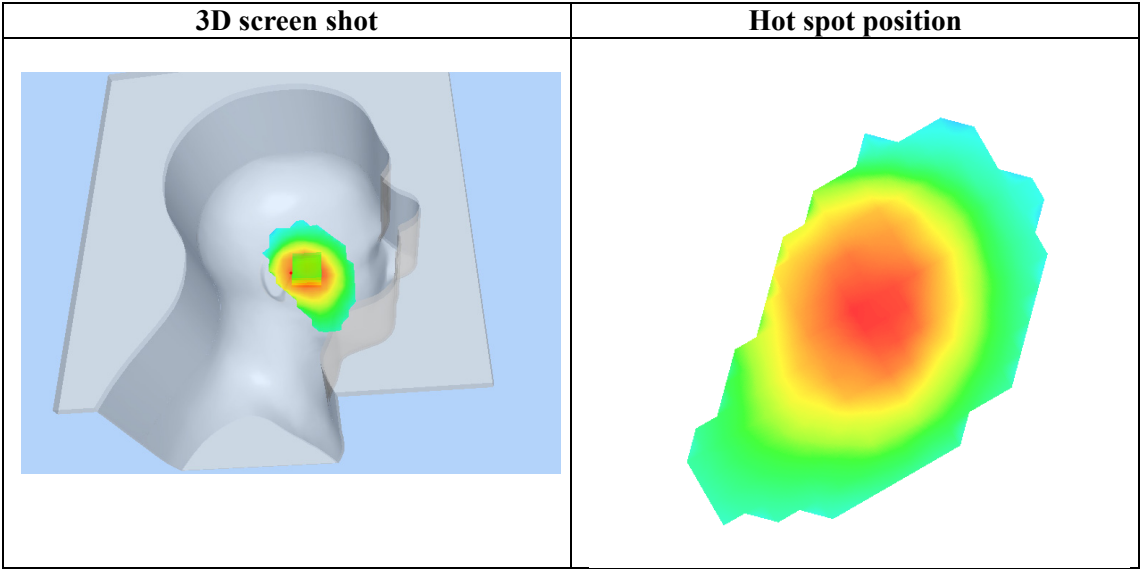
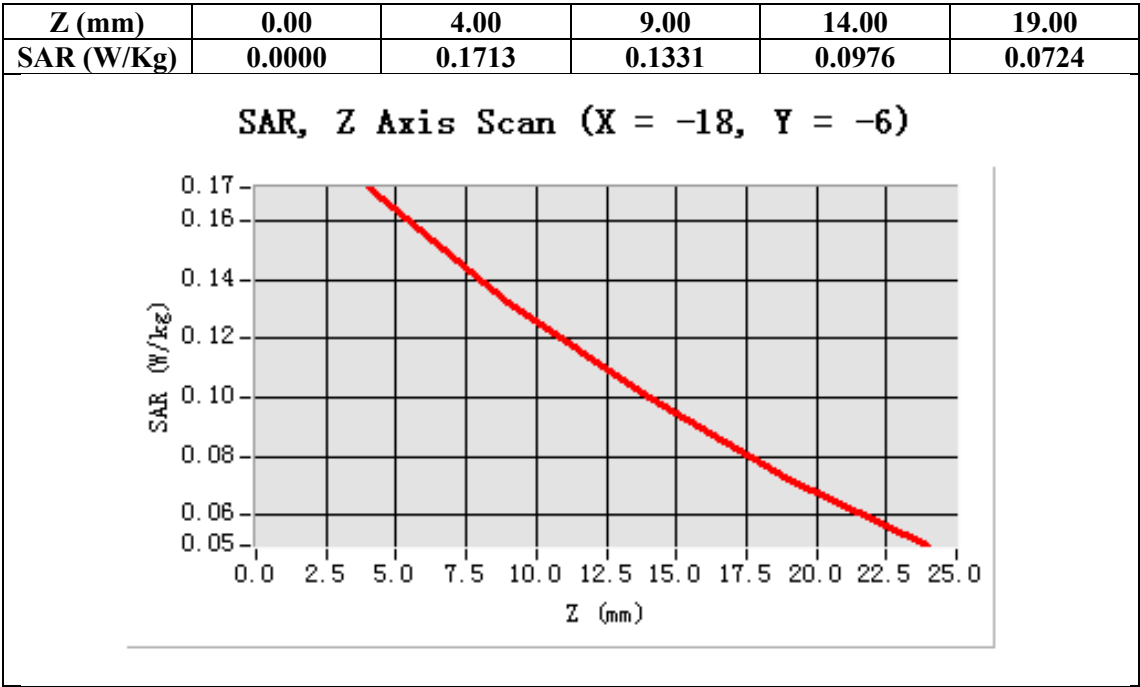

Test Laboratory: AGC Lab
Hotspot Mid-Tilt-Right
DUT: CDMA Smart phone; Type: WOW 818

Date: Sep.09, 2013

Communication System: Wi-Fi; Communication System Band: Hotspot; Duty Cycle: 1:1; Conv.F=4.19;
Frequency: 2437 MHz; Medium parameters used: $f = 2450$ MHz; $\sigma = 1.77$ mho/m; $\epsilon_r = 40.63$; $\rho = 1000$ kg/m³ ;
Phantom section: Right Section
Ambient temperature (°C): 21, Liquid temperature (°C): 21

- SATIMO Configuration:
Probe: EP165; Calibrated: 01/31/2013
- Sensor-Surface: 4mm (Mechanical Surface Detection)
 - Phantom: Flat Phantom; Type: Elliptical Phantom
 - Measurement SW: OpenSAR V4_02_01

Configuration/Hotspot Mid- Tilt-Right/Area Scan: Measurement grid: dx=8mm, dy=8mm
Configuration/Hotspot Mid- Tilt-Right/Zoom Scan: Measurement grid: dx=8mm, dy=8mm, dz=5mm;

Area Scan	sam_direct_droit2_surf8mm.txt
Zoom Scan	5x5x7,dx=8mm dy=8mm dz=5mm,Very fast
Phantom	Right head
Device Position	Tilt
Band	2450MHz
Channels	Middle
Signal	TDMA (Crest factor: 8.0)

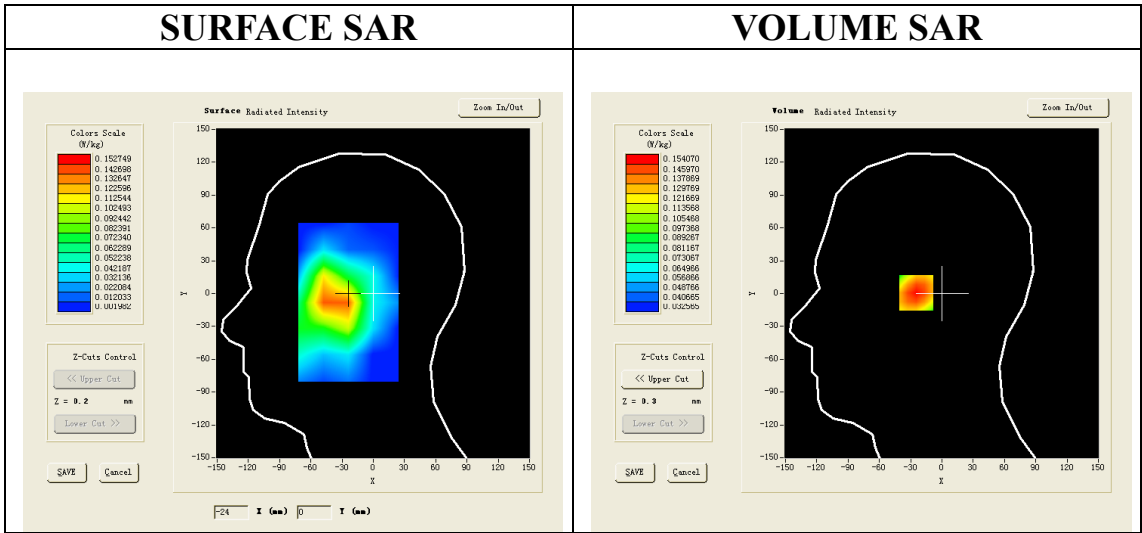

Maximum location: X=-22.00, Y=1.00

SAR 10g (W/Kg)	0.106871
SAR 1g (W/Kg)	0.144527

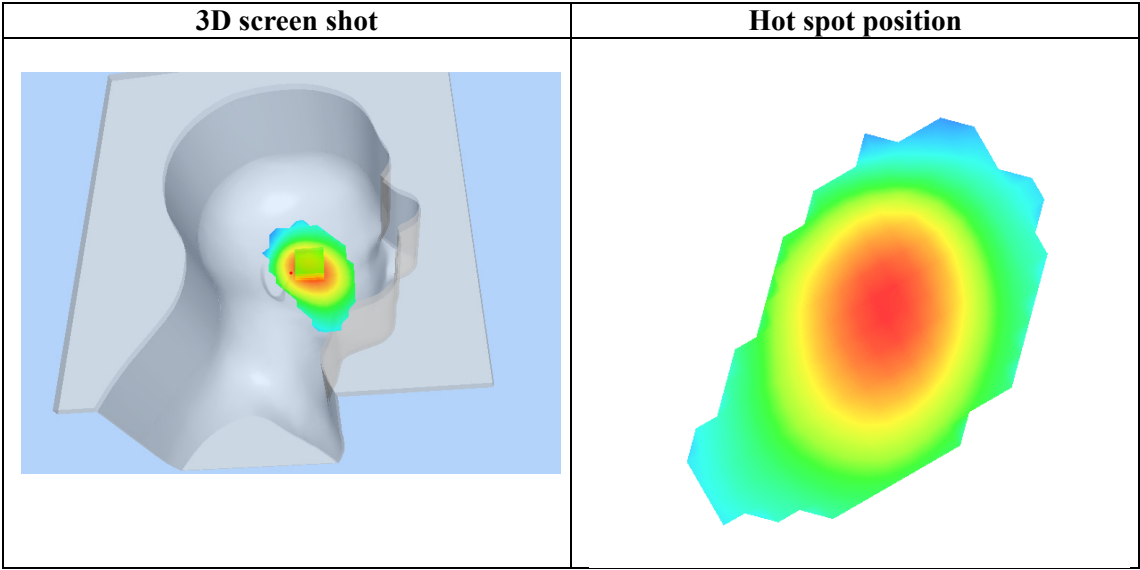
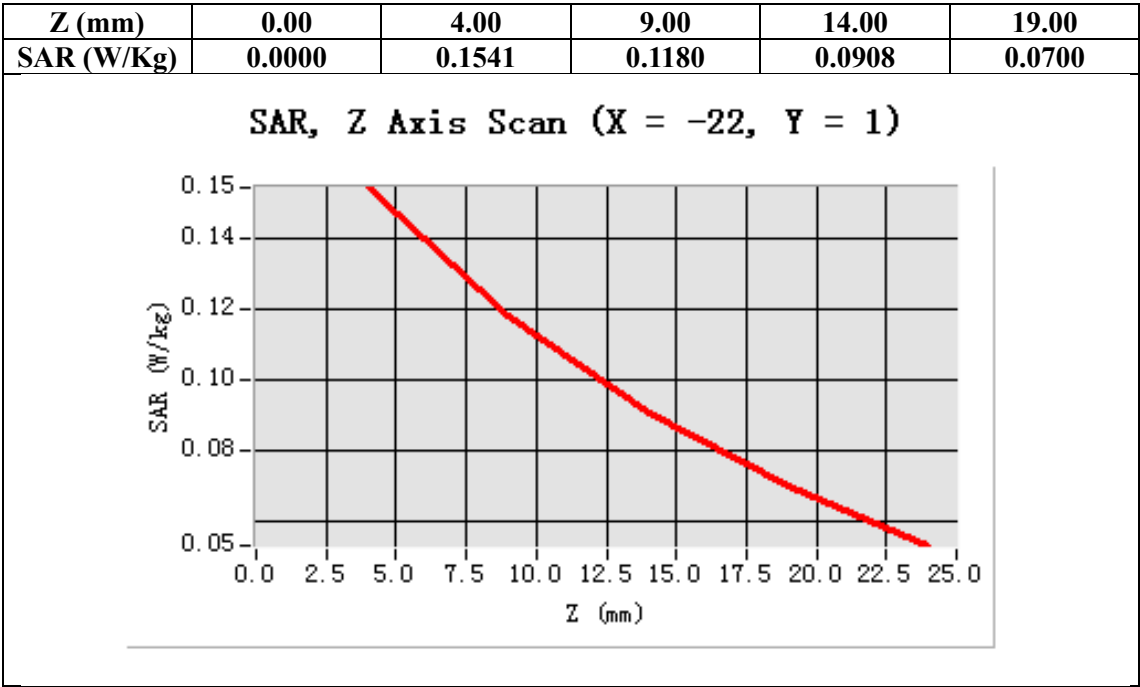

Test Laboratory: AGC Lab
Hotspot Mid-Body-Worn- Back (MS)
DUT: CDMA Smart phone; Type: WOW 818

Date: Sep.09, 2013

Communication System: Wi-Fi; Communication System Band: Hotspot; Duty Cycle: 1:1; Conv.F=4.32;
Frequency: 2437 MHz; Medium parameters used: $f = 2450$ MHz; $\sigma = 1.92$ mho/m; $\epsilon_r = 53.16$; $\rho = 1000$ kg/m³ ;
Phantom section: Flat Section
Ambient temperature (°C):21, Liquid temperature (°C):21

- SATIMO Configuration:
Probe: EP165; Calibrated: 01/31/2013
- Sensor-Surface: 4mm (Mechanical Surface Detection)
 - Phantom: Flat Phantom; Type: Elliptical Phantom
 - Measurement SW: OpenSAR V4_02_01

Configuration/Hotspot Mid- Body- Back /Area Scan (6x8x1): Measurement grid: dx=8mm, dy=8mm
Configuration/Hotspot Mid- Body- Back /Zoom Scan (5x5x7)/Cube 0: Measurement grid: dx=8mm, dy=8mm, dz=5mm;

Area Scan	surf_sam_plan.txt
ZoomScan	5x5x7,dx=8mm dy=8mm dz=5mm,Very fast
Phantom	Validation plane
Device Position	Body Back
Band	2450MHz
Channels	Middle
Signal	TDMA (Crest factor: 8.0)

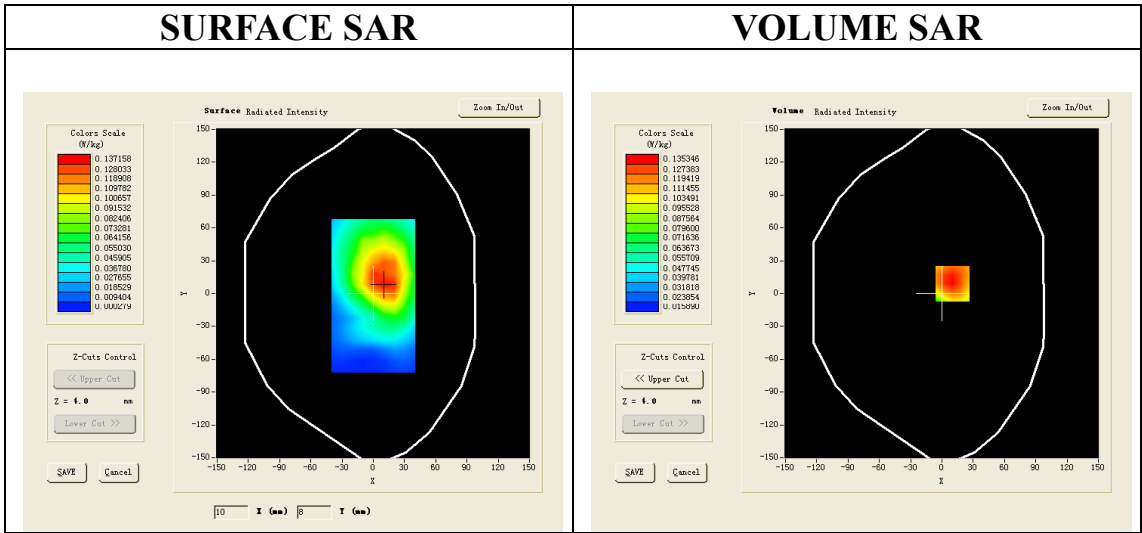

Maximum location: X=10.00, Y=9.00

SAR 10g (W/Kg)	0.087058
SAR 1g (W/Kg)	0.136521

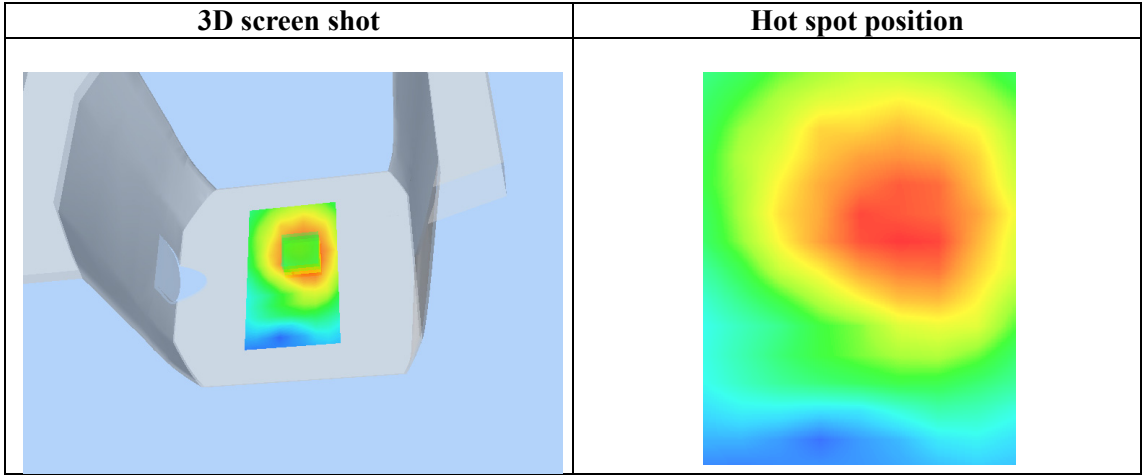
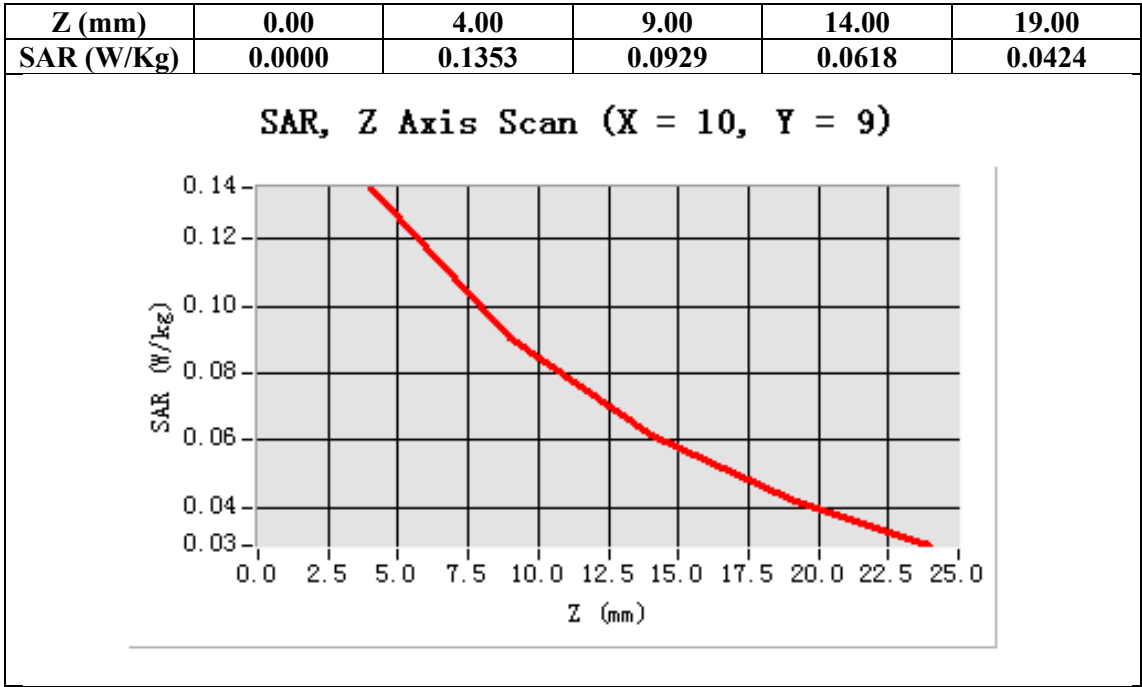

Test Laboratory: AGC Lab
Hotspot Mid-Body -Front (MS)
DUT: CDMA Smart phone; Type: WOW 818

Date: Sep.09, 2013

Communication System: Wi-Fi; Communication System Band: Hotspot; Duty Cycle: 1:1; Conv.F=4.32;
Frequency: 2437 MHz; Medium parameters used: $f = 2450$ MHz; $\sigma = 1.92$ mho/m; $\epsilon_r = 53.16$; $\rho = 1000$ kg/m³ ;
Phantom section: Flat Section
Ambient temperature (°C):21, Liquid temperature (°C):21

- SATIMO Configuration:
Probe: EP165; Calibrated: 01/31/2013
- Sensor-Surface: 4mm (Mechanical Surface Detection)
 - Phantom: Flat Phantom; Type: Elliptical Phantom
 - Measurement SW: OpenSAR V4_02_01

Configuration/Hotspot Mid-Body- Front /Area Scan: Measurement grid: dx=8mm, dy=8mm
Configuration/Hotspot Mid-Body- Front /Zoom Scan: Measurement grid: dx=8mm, dy=8mm, dz=5mm;

Area Scan	surf_sam_plan.txt
ZoomScan	5x5x7,dx=8mm dy=8mm dz=5mm,Very fast
Phantom	Validation plane
Device Position	Body Front
Band	2450MHz
Channels	Middle
Signal	TDMA (Crest factor: 8.0)

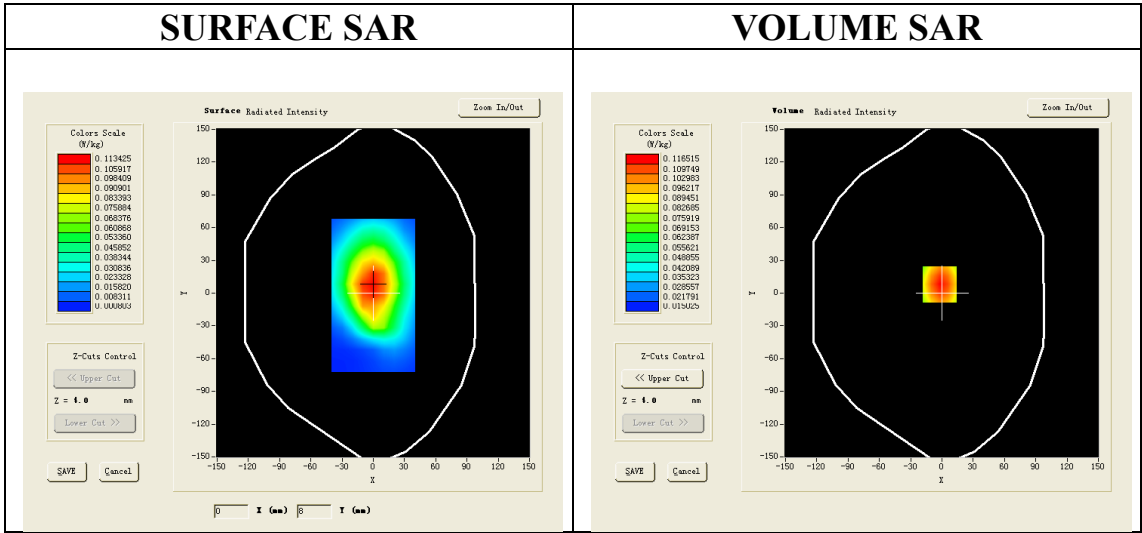

Maximum location: X=-2.00, Y=8.00

SAR 10g (W/Kg)	0.079204
SAR 1g (W/Kg)	0.124328

