

# FCC 47 CFR PART 15 SUBPART C AND ANSI C63.10:2013 TEST REPORT

For

**MX-LOCare**

**Model : BR1**

**Trade Name : MobilMAX**

Issued for

**MobilMax Technology Inc.**

**2F-5, No. 28, Tai-Yuan St., Chupei City, Hsinchu County 302, Taiwan**

Issued by

**Compliance Certification Services Inc.  
Hsinchu Lab.**

**No.989-1, Wenshan Rd., Shangshan Village,  
Qionglin Township, Hsinchu County 30741, Taiwan (R.O.C.)**

**TEL: +886-3-5921698**

**FAX: +886-3-5921108**

**<http://www.ccsrf.com>**

**E-Mail : [service@ccsrf.com](mailto:service@ccsrf.com)**

**Issued Date: July 20, 2015**



**Note:** This report shall not be reproduced except in full, without the written approval of Compliance Certification Services Inc. This document may be altered or revised by Compliance Certification Services Inc. personnel only, and shall be noted in the revision section of the document. The client should not use it to claim product endorsement by TAF or any government agencies. The test results of this report relate only to the tested sample identified in this report.

## Revision History

| Rev. | Issue Date | Revisions     | Effect Page | Revised By |
|------|------------|---------------|-------------|------------|
| 00   | 07/20/2015 | Initial Issue | All Page 84 | Dola Hsieh |
|      |            |               |             |            |
|      |            |               |             |            |
|      |            |               |             |            |
|      |            |               |             |            |

## TABLE OF CONTENTS

| TITLE  | PAGE NO.  |
|--|-----------|
| <b>1. TEST REPORT CERTIFICATION .....</b>    | <b>4</b>  |
| <b>2. EUT DESCRIPTION .....</b>              | <b>5</b>  |
| <b>3. DESCRIPTION OF TEST MODES .....</b>    | <b>6</b>  |
| <b>4. TEST METHODOLOGY .....</b>             | <b>8</b>  |
| <b>5. FACILITIES AND ACCREDITATION .....</b> | <b>8</b>  |
| 5.1 FACILITIES .....                         | 8         |
| 5.2 ACCREDITATIONS.....                      | 8         |
| 5.3 MEASUREMENT UNCERTAINTY .....            | 9         |
| <b>6. SETUP OF EQUIPMENT UNDER TEST.....</b> | <b>10</b> |
| <b>7. FCC PART 15.247 REQUIREMENTS.....</b>  | <b>11</b> |
| 7. 1 DUTY CYCLE CORRECTION FACTOR.....       | 11        |
| 7.2 20dB BANDWIDTH FOR HOPPING .....         | 13        |
| 7.3 MAXIMUM PEAK OUTPUT POWER .....          | 19        |
| 7.4 AVERAGE POWER .....                      | 21        |
| 7.5 HOPPING CHANNEL SEPARATION.....          | 23        |
| 7.6 NUMBER OF HOPPING FREQUENCY USED.....    | 29        |
| 7.7 DWELL TIME ON EACH CHANNEL.....          | 32        |
| 7.8 CONDUCTED SPURIOUS EMISSION .....        | 47        |
| 7.9 RADIATED EMISSION.....                   | 55        |
| 7.10 CONDUCTED EMISSION.....                 | 76        |
| <b>APPENDIX SETUP PHOTOS .....</b>           | <b>81</b> |

## 1. TEST REPORT CERTIFICATION

**Applicant** : MobilMax Technology Inc.  
**Address** : 2F-5, No. 28, Tai-Yuan St., Chupei City, Hsinchu County  
302, Taiwan  
**Equipment Under Test** : MX-LOCare  
**Model** : BR1  
**Trade Name** : MobilMAX  
**Tested Date** : June 08 ~ 24, 2015

| APPLICABLE STANDARD                           |             |
|---|-------------|
| Standard                                      | Test Result |
| FCC Part 15 Subpart C AND<br>ANSI C63.10:2013 | PASS        |

WE HEREBY CERTIFY THAT: The above equipment has been tested by Compliance Certification Services Inc., and found compliance with the requirements set forth in the technical standards mentioned above. The results of testing in this report apply only to the product/system, which was tested. Other similar equipment will not necessarily produce the same results due to production tolerance and measurement uncertainties.

**Approved by:**



Sb. Lu  
Sr. Engineer

**Reviewed by:**



Gundam Lin  
Sr. Engineer

## 2. EUT DESCRIPTION

|                           |  |
|---------------------------|--|
| <b>Product Name</b>       | MX-LOCare  |
| <b>Model Number</b>       | BR1  |
| <b>Identify Number</b>    | T150608S03   |
| <b>Received Date</b>      | June 08, 2015  |
| <b>Frequency Range</b>    | 2402MHz to 2480MHz f = 2402 + nMHz, n = 0, .....78               |
| <b>Transmit Power</b>     | 5.28 dBm (0.0034W)   |
| <b>Channel Spacing</b>    | 1MHz   |
| <b>Channel Number</b>     | 79 Channels  |
| <b>Transmit Data Rate</b> | GFSK (1Mbps), $\pi/4$ -DQPSK (2Mbps), 8-DPSK (3Mbps)             |
| <b>Type of Modulation</b> | Frequency Hopping Spread Spectrum                                |
| <b>Antenna Type</b>       | FPC Antenna , Antenna Gain : 0.51 dBi                            |
| <b>Power Rating</b>       | 3.7Vdc, 350mAh (For Battery)<br>3.7Vdc (For Charging)            |
| <b>Test Voltage</b>       | 120Vac, 60Hz   |
| <b>I/O Port</b>           | EUT : Charge Port x 1<br>Ducking : USB Port x 1, Charge Port x 1 |
| <b>Signal Cable</b>       | Shielded mini USB cable, 0.9m x 1 (Detachable)                   |

### Power Adapter :

| No. | Manufacturer | Model No.                  | Power Input                  | Power Output |
|-----|--------------|----------------------------|------------------------------|--------------|
| 1   | DVE          | DSA-5PFK-05<br>FUS 050100a | 100-240Vac,<br>50/60Hz, 0.2A | +5Vdc, 1A    |

### Remark :

1. The sample selected for test was engineering sample that approximated to production product and was provided by manufacturer.
2. For more details, please refer to the User's manual of the EUT.
3. This submittal(s) (test report) is intended for FCC ID: 2AAYELOCAREBR1 filing to comply with Section 15.207, 15.209 and 15.247 of the FCC Part 15, Subpart C Rules.

### 3. DESCRIPTION OF TEST MODES

The EUT (MX-LOCare) had been tested under operating condition.

There are three channels have been tested as following :

| Channel | Frequency (MHz) |
|---------|-----------------|
| Low     | 2402            |
| Middle  | 2441            |
| High    | 2480            |

#### Conducted Emission / Radiated Emission Test (Below 1 GHz)

1. The following test modes were scanned during the preliminary test:

| No. | Pre-Test Mode    |
|-----|------------------|
| 1   | Normal Operating |

2. After the preliminary scan, the following test mode was found to produce the highest emission level.

| Final Test Mode |                    |        |
|-----------------|--------------------|--------|
| Emission        | Radiated Emission  | Mode 1 |
|                 | Conducted Emission | Mode 1 |

**Remark :** Then, the above highest emission mode of the configuration of the EUT and cable was chosen for all final test items.

**Radiated Emission Test (Above 1 GHz):**

Pre-Scan has been conducted to determine the worst-case mode from all possible combinations between available modulations, data rates and antenna ports (if EUT with antenna diversity architecture).

Following channel(s) was (were) selected for the final test as listed below.

| Tested Channel | Modulation Technology | Modulation Type | Packet Type |
|----------------|-----------------------|-----------------|-------------|
| Low, Mid, High | FHSS                  | GFSK            | DH5         |
| Low, Mid, High | FHSS                  | 8-DPSK          | 3-DH5       |

**Bandedge Measurement :**

Pre-Scan has been conducted to determine the worst-case mode from all possible combinations between available modulations, data rates and antenna ports (if EUT with antenna diversity architecture).

Following channel(s) was (were) selected for the final test as listed below.

| Tested Channel | Modulation Technology | Modulation Type | Packet Type |
|----------------|-----------------------|-----------------|-------------|
| Low, High      | FHSS                  | GFSK            | DH5         |
| Low, High      | FHSS                  | 8-DPSK          | 3-DH5       |

**Antenna Port Conducted Measurement :**

Pre-Scan has been conducted to determine the worst-case mode from all possible combinations between available modulations, data rates and antenna ports (if EUT with antenna diversity architecture).

Following channel(s) was (were) selected for the final test as listed below.

| Tested Channel | Modulation Technology | Modulation Type | Packet Type |
|----------------|-----------------------|-----------------|-------------|
| Low, Mid, High | FHSS                  | GFSK            | DH5         |
| Low, Mid, High | FHSS                  | 8-DPSK          | 3-DH5       |

**Remark:** The field strength of spurious emission was measured in the following position: EUT stand-up position(Z axis), lie-down position(X, Y axis). The worst emission was found in lie-down position(Y axis) and the worst case was recorded.

## 4. TEST METHODOLOGY

The tests documented in this report were performed in accordance with ANSI C63.10:2013 and FCC CFR 47, 15.207, 15.209 and 15.247.

## 5. FACILITIES AND ACCREDITATION

### 5.1 FACILITIES

All measurement facilities used to collect the measurement data are located at

No.989-1, Wenshan Rd., Shangshan Village,  
Qionglin Township, Hsinchu County 30741, Taiwan (R.O.C.)

The sites are constructed in conformance with the requirements of ANSI C63.10:2013 and CISPR 22. All receiving equipment conforms to CISPR 16-1-1, CISPR 16-1-2, CISPR 16-1-3, CISPR 16-1-4, CISPR 16-1-5.

### 5.2 ACCREDITATIONS

Our laboratories are accredited and approved by the following approval agencies according to ISO/IEC 17025.

|               |     |
|---------------|-----|
| <b>Taiwan</b> | TAF |
|---------------|-----|

The measuring facility of laboratories has been authorized or registered by the following approval agencies.

|               |                 |
|---------------|-----------------|
| <b>Canada</b> | INDUSTRY CANADA |
| <b>Japan</b>  | VCCI            |
| <b>Taiwan</b> | BSMI            |
| <b>USA</b>    | FCC MRA         |

Copies of granted accreditation certificates are available for downloading from our web site, <http://www.ccsrf.com>

**Remark:** FCC Designation Number TW1027.



### 5.3 MEASUREMENT UNCERTAINTY

The following table is for the measurement uncertainty, which is calculated as per the document CISPR 16-4-2.

| PARAMETER   | UNCERTAINTY |
|---|-------------|
| Semi Anechoic Chamber (966 Chamber_B) / Radiated Emission, 30 to 1000 MHz | +/- 3.97    |
| Semi Anechoic Chamber (966 Chamber_B) / Radiated Emission, 1 to 18GHz     | +/- 3.58    |
| Semi Anechoic Chamber (966 Chamber_B) / Radiated Emission, 18 to 26 GHz   | +/- 3.59    |
| Semi Anechoic Chamber (966 Chamber_B) / Radiated Emission, 26 to 40 GHz   | +/- 3.81    |
| Semi Anechoic Chamber (966 Chamber_C) / Radiated Emission, 30 to 1000 MHz | +/- 3.97    |
| Semi Anechoic Chamber (966 Chamber_C) / Radiated Emission, 1 to 18GHz     | +/- 3.58    |
| Semi Anechoic Chamber (966 Chamber_C) / Radiated Emission, 18 to 26 GHz   | +/- 3.59    |
| Semi Anechoic Chamber (966 Chamber_C) / Radiated Emission, 26 to 40 GHz   | +/- 3.81    |
| Conducted Emission (Mains Terminals), 9kHz to 30MHz                       | +/- 2.48    |

This uncertainty represents an expanded uncertainty expressed at approximately the 95% confidence level using a coverage factor of k=2.

Consistent with industry standard (e.g. CISPR 22, clause 11, Measurement Uncertainty) determining compliance with the limits shall be base on the results of the compliance measurement. Consequently the measure emissions being less than the maximum allowed emission result in this be a compliant test or passing test.

The acceptable measurement uncertainty value without requiring revision of the compliance statement is base on conducted and radiated emissions being less than  $U_{CISPR}$  which is 3.6dB and 5.2dB respectively. CCS values (called  $U_{Lab}$  in CISPR 16-4-2) is less than  $U_{CISPR}$  as shown in the table above. Therefore, MU need not be considered for compliance.

## 6. SETUP OF EQUIPMENT UNDER TEST

### SUPPORT EQUIPMENT

| No. | Product     | Manufacturer | Model No.     | Serial No.       |
|-----|-------------|--------------|---------------|------------------|
| 1   | Notebook PC | HP           | ProBook 4421s | CNF03242PJ       |
| 2   | Beacon      | MobilMax     | MX-Beacon1    | MXB_151_00000011 |

### SETUP DIAGRAM FOR TESTS

EUT & peripherals setup diagram is shown in appendix setup photos.

### EUT OPERATING CONDITION

#### **RF Mode :**

1. EUT & peripherals setup diagram is shown in appendix setup photos.
2. TX mode(GFSK)  
Continue TX  
LO Freq: 2402, 2441, 2480  
Power set: 6  
DataRate: DH5  
TX mode (8-DPSK)  
Continue TX  
LO Freq: 2402, 2441, 2480  
Power set: 6  
DataRate: 3DH5
3. All of the functions are under run.
4. Start test.

#### **Normal Mode :**

All the equipment/cables were placed in the worst-case configuration to maximize the emission during the test. Grounding was established in accordance with the manufacturer's requirements and conditions for the intended use.

1. EUT & peripherals setup diagram is shown in appendix setup photos.
2. Bracelet GPS locator through the internet to the server.
3. Bracelet GPS locator link to EUT with BT.
4. EUT through the GPS to the server.
5. All of the functions are under run.
6. Start test.

## 7. FCC PART 15.247 REQUIREMENTS

### 7.1 DUTY CYCLE CORRECTION FACTOR

#### LIMITS

Limit : N/A

#### TEST EQUIPMENT

| Name of Equipment   | Manufacturer | Model  | Serial Number | Calibration Due |
|---------------------|--------------|--------|---------------|-----------------|
| EXA Signal Analyzer | Agilent      | N9010A | MY52220817    | 03/19/2016      |

*Remark: Each piece of equipment is scheduled for calibration once a year.*

#### TEST SETUP



#### TEST PROCEDURE

1. Set center frequency of spectrum analyzer = operating frequency.
2. Set the spectrum analyzer as RBW, VBW=100kHz & 1MHz, Span = 0Hz.
3. Repeat above procedures until all frequency measured were complete.

**TEST RESULTS**

Tp = 100 (ms)

Ton = 2.87 (ms)

Duty Cycle Correction Factor =  $20 \times \log (Ton / Tp)$

$$= 20 \times \log (2.87 / 100) = -30.84$$

Because -30.84 less than -20, so the Duty Cycle Correction Factor = -20

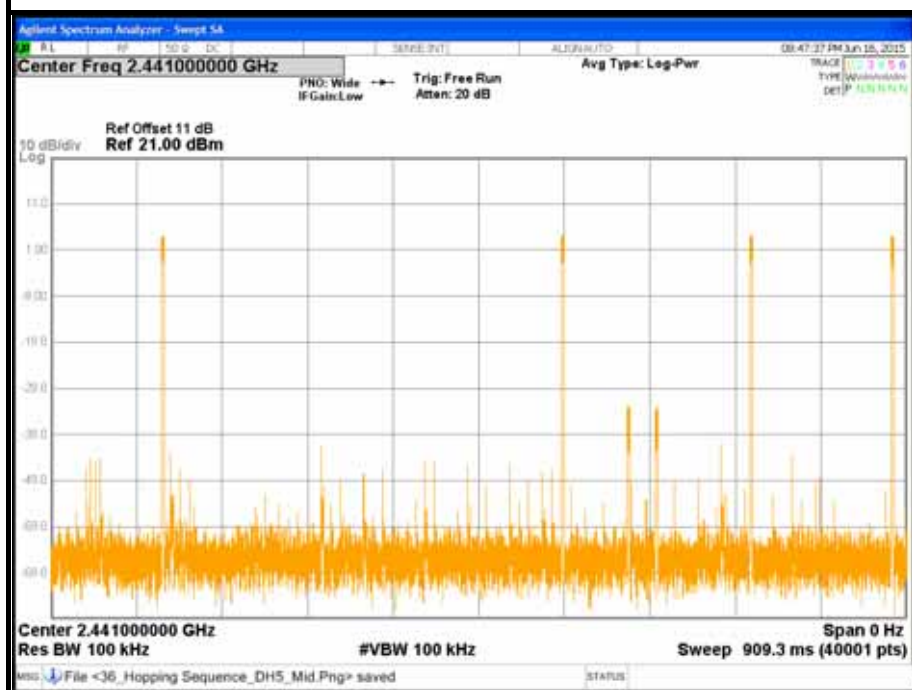
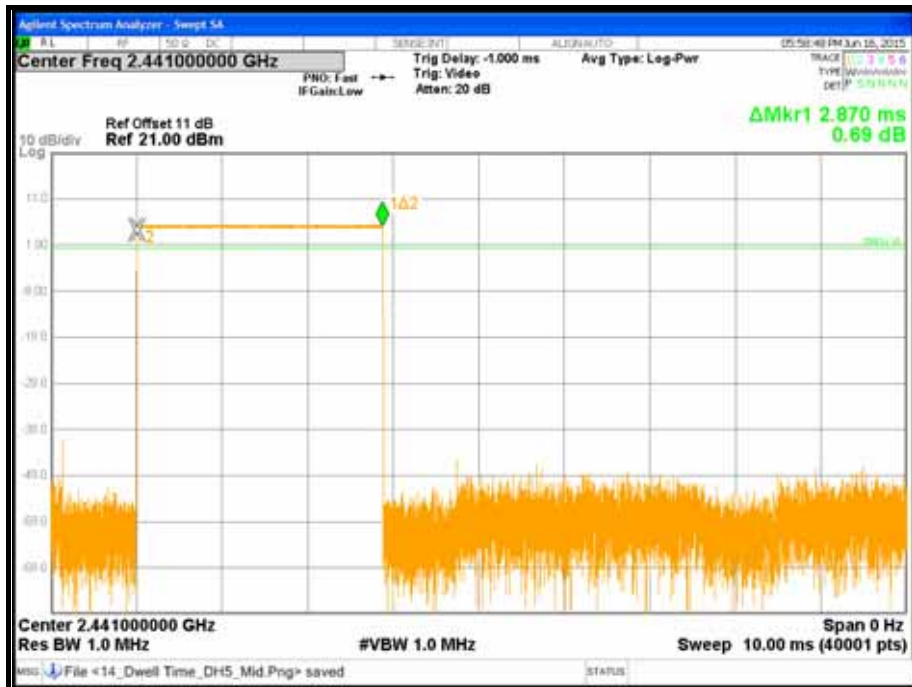

## 7.2 20dB BANDWIDTH FOR HOPPING

### LIMITS

Limit : N/A

### TEST EQUIPMENT

| Name of Equipment   | Manufacturer | Model  | Serial Number | Calibration Due |
|---------------------|--------------|--------|---------------|-----------------|
| EXA Signal Analyzer | Agilent      | N9010A | MY52220817    | 03/19/2016      |

*Remark: Each piece of equipment is scheduled for calibration once a year.*

### TEST SETUP



### TEST PROCEDURE

1. The 20dB band width was measured with a spectrum analyzer connected to RF antenna connector(conducted measurement) while EUT was operating in transmit mode at the appropriate center frequency. The analyzer center frequency was set to the EUT carrier frequency, using the analyzer. Display Line and Marker Delta functions, the 20dB band width of the emission was determined.
2. Span = approximately 2 to 3 times the 20 dB bandwidth, centered on a hopping channel.
3. RBW  $\geq$  1% of the 20 dB bandwidth.
4. VBW  $\geq$  RBW.
5. Sweep = auto.

**TEST RESULTS**

Modulation Type: GFSK, CFG PKT Packet Type: 15 Packet Size: 339 (DH5)

| Channel | Channel Frequency (MHz) | 20dB Bandwidth (MHz) | Result |
|---------|-------------------------|----------------------|--------|
| Low     | 2402                    | 0.92198              | N/A    |
| Middle  | 2441                    | 0.92153              | N/A    |
| High    | 2480                    | 0.92490              | N/A    |

Modulation Type: 8-DPSK, CFG PKT Packet Type: 31 Packet Size: 1021 (3-DH5)

| Channel | Channel Frequency (MHz) | 20dB Bandwidth (MHz) | Result |
|---------|-------------------------|----------------------|--------|
| Low     | 2402                    | 1.28168              | N/A    |
| Middle  | 2441                    | 1.28138              | N/A    |
| High    | 2480                    | 1.28415              | N/A    |

### 20dB BANDWIDTH

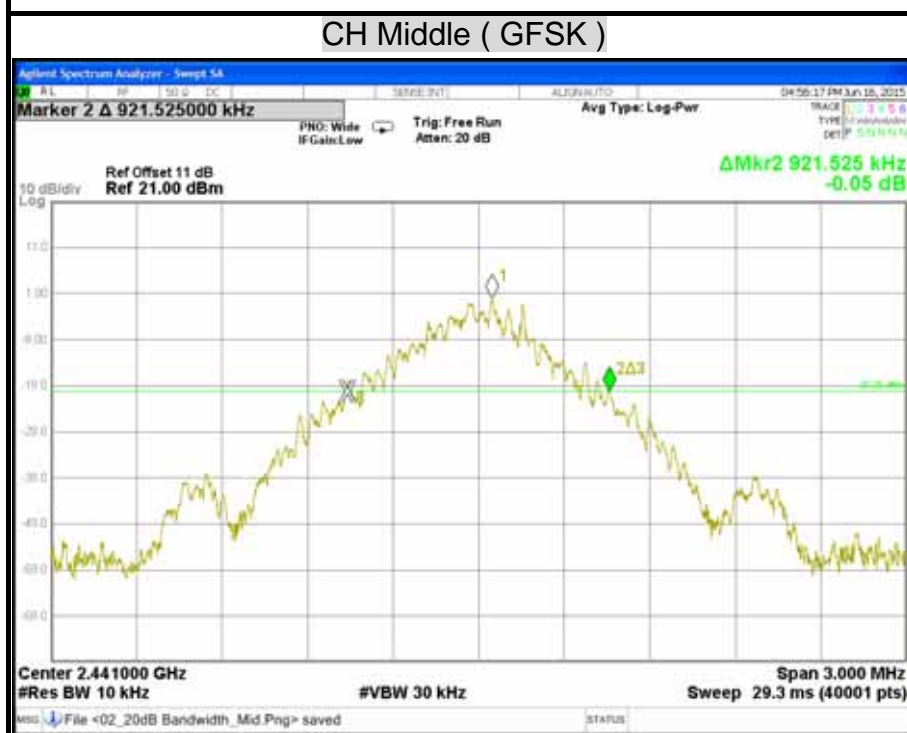









### 7.3 MAXIMUM PEAK OUTPUT POWER

#### LIMITS

§15.247(b)(1) For frequency hopping systems operating in the 2400-2483.5 MHz band employing at least 75 non-overlapping hopping channels, and all frequency hopping systems in the 5725-5850 MHz band: 1 watt. For all other frequency hopping systems in the 2400-2483.5 MHz band: 0.125 watts.

#### TEST EQUIPMENT

| Name of Equipment | Manufacturer | Model   | Serial Number | Calibration Due |
|-------------------|--------------|---------|---------------|-----------------|
| Power Meter       | Anritsu      | ML2495A | 1149001       | 12/11/2015      |
| Power Sensor      | Anritsu      | MA2411B | 1126148       | 12/11/2015      |

*Remark: Each piece of equipment is scheduled for calibration once a year.*

#### TEST SETUP



#### TEST PROCEDURE

The transmitter output is connected to the power meter. The power meter is set to the peak power detection.

**TEST RESULTS**

Modulation Type: GFSK ,CFG PKT Packet Type: 15 Packet Size: 339 (DH5)

| Channel | Channel Frequency (MHz) | Peak Power |        | Peak Power Limit |       | Result |
|---------|-------------------------|------------|--------|------------------|-------|--------|
|         |                         | (dBm)      | (W)    | (dBm)            | (W)   |        |
| Low     | 2402                    | 5.27       | 0.0034 | 20.97            | 0.125 | PASS   |
| Middle  | 2441                    | 5.28       | 0.0034 | 20.97            | 0.125 | PASS   |
| High    | 2480                    | 5.17       | 0.0033 | 20.97            | 0.125 | PASS   |

**Remark:** The cable assembly insertion loss of 11 dB (including 10 dB pad and 1 dB cable) was Entered as an offset in the power meter to allow for direct reading of power.

Modulation Type: 8-DPSK ,CFG PKT Packet Type: 31 Packet Size: 1021 (3-DH5)

| Channel | Channel Frequency (MHz) | Peak Power |        | Peak Power Limit |       | Result |
|---------|-------------------------|------------|--------|------------------|-------|--------|
|         |                         | (dBm)      | (W)    | (dBm)            | (W)   |        |
| Low     | 2402                    | 4.95       | 0.0031 | 20.97            | 0.125 | PASS   |
| Middle  | 2441                    | 4.98       | 0.0031 | 20.97            | 0.125 | PASS   |
| High    | 2480                    | 4.88       | 0.0031 | 20.97            | 0.125 | PASS   |

**Remark:** The cable assembly insertion loss of 11 dB (including 10 dB pad and 1 dB cable) was Entered as an offset in the power meter to allow for direct reading of power.

## 7.4 AVERAGE POWER

### LIMITS

None; for reporting purposes only.

### TEST EQUIPMENT

| Name of Equipment | Manufacturer | Model   | Serial Number | Calibration Due |
|-------------------|--------------|---------|---------------|-----------------|
| Power Meter       | Anritsu      | ML2495A | 1149001       | 12/11/2015      |
| Power Sensor      | Anritsu      | MA2411B | 1126148       | 12/11/2015      |

*Remark: Each piece of equipment is scheduled for calibration once a year.*

### TEST SETUP



### TEST PROCEDURE

The transmitter output is connected to the power meter. The power meter is set to the average power detection.

**TEST RESULTS**

Modulation Type: GFSK ,CFG PKT Packet Type: 15 Packet Size: 339 (DH5)

| Channel | Channel Frequency (MHz) | Average Power (dBm) |
|---------|-------------------------|---------------------|
| Low     | 2402                    | 5.01                |
| Middle  | 2441                    | 5.02                |
| High    | 2480                    | 4.92                |

**Remark:** The cable assembly insertion loss of 10.5 dB (including 10 dB pad and 0.5 dB cable) was Entered as an offset in the power meter to allow for direct reading of power.

Modulation Type: 8-DPSK ,CFG PKT Packet Type: 31 Packet Size: 1021 (3-DH5)

| Channel | Channel Frequency (MHz) | Average Power (dBm) |
|---------|-------------------------|---------------------|
| Low     | 2402                    | 2.09                |
| Middle  | 2441                    | 2.15                |
| High    | 2480                    | 2.10                |

**Remark:** The cable assembly insertion loss of 10.5 dB (including 10 dB pad and 0.5 dB cable) was Entered as an offset in the power meter to allow for direct reading of power.

## 7.5 HOPPING CHANNEL SEPARATION

### LIMITS

§15.247(a)(1) Frequency hopping systems shall have hopping channel carrier frequencies separated by a minimum of 25 kHz or the 20 dB bandwidth of the hopping channel, whichever is greater. Alternatively, frequency hopping systems operating in the 2400-2483.5 MHz band may have hopping channel carrier frequencies that are separated by 25 kHz or two-thirds of the 20 dB bandwidth of the hopping channel, whichever is greater, provided the systems operate with an output power no greater than 125 mW. The system shall hop to channel frequencies that are selected at the system hopping rate from a pseudorandomly ordered list of hopping frequencies. Each frequency must be used equally on the average by each transmitter. The system receivers shall have input bandwidths that match the hopping channel bandwidths of their corresponding transmitters and shall shift frequencies in synchronization with the transmitted signals.

### TEST EQUIPMENT

| Name of Equipment   | Manufacturer | Model  | Serial Number | Calibration Due |
|---------------------|--------------|--------|---------------|-----------------|
| EXA Signal Analyzer | Agilent      | N9010A | MY52220817    | 03/19/2016      |

*Remark: Each piece of equipment is scheduled for calibration once a year.*

### TEST SETUP



### TEST PROCEDURE

1. Check the calibration of the measuring instrument using either an internal calibrator or a known signal from an external generator.
2. Position the EUT as shown in test setup without connection to measurement instrument. Turn on the EUT and connect it to measurement instrument. Then set it to any one convenient frequency within its operating range.
3. By using the MaxHold function record the separation of adjacent channels.
4. Measure the frequency difference of these two adjacent channels by spectrum analyzer MARK function. And then plot the result on spectrum analyzer screen.
5. Span = wide enough to capture the peaks of two adjacent channels.
6. Resolution (or IF) Bandwidth (RBW)  $\geq$  1% of the span.
7. Video (or Average) Bandwidth (VBW)  $\geq$  RBW.
8. Sweep = auto.
9. Repeat above procedures until all frequencies measured were complete.

**TEST RESULTS**

Refer to section 7.2, 20dB bandwidth measurement, the measured channel separation should be greater than two-third of 20dB bandwidth or Minimum bandwidth.

Modulation Type: GFSK, CFG PKT Packet Type: 15 Packet Size: 339 (DH5)

| Channel | Channel Frequency (MHz) | Adjacent Hopping Channel Separation (kHz) | Two –third of 20dB bandwidth (kHz) | Minimum Bandwidth | Result |
|---------|-------------------------|---|------------------------------------|-------------------|--------|
| Low     | 2402                    | 1000                                      | 614.65                             | 25 kHz            | PASS   |
| Middle  | 2441                    | 1000                                      | 614.35                             | 25 kHz            | PASS   |
| High    | 2480                    | 1000                                      | 616.60                             | 25 kHz            | PASS   |

Modulation Type: 8-DPSK, CFG PKT Packet Type: 31 Packet Size: 1021 (3-DH5)

| Channel | Channel Frequency (MHz) | Adjacent Hopping Channel Separation (kHz) | Two –third of 20dB bandwidth (kHz) | Minimum Bandwidth | Result |
|---------|-------------------------|---|------------------------------------|-------------------|--------|
| Low     | 2402                    | 1000                                      | 854.45                             | 25 kHz            | PASS   |
| Middle  | 2441                    | 1000                                      | 854.25                             | 25 kHz            | PASS   |
| High    | 2480                    | 1000                                      | 856.10                             | 25 kHz            | PASS   |



**HOPPING CHANNEL SEPARATION**

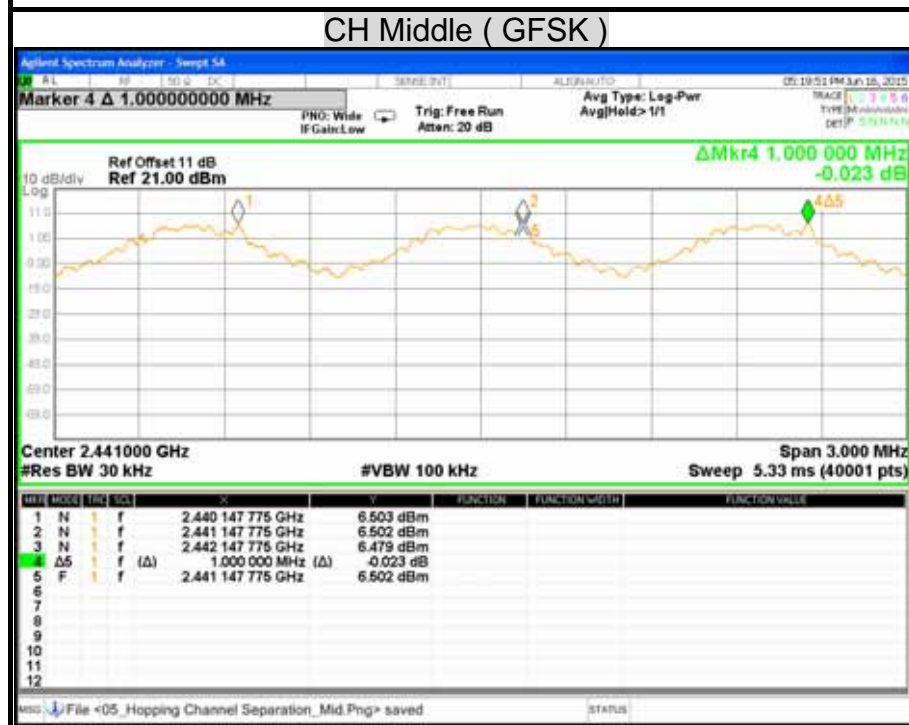
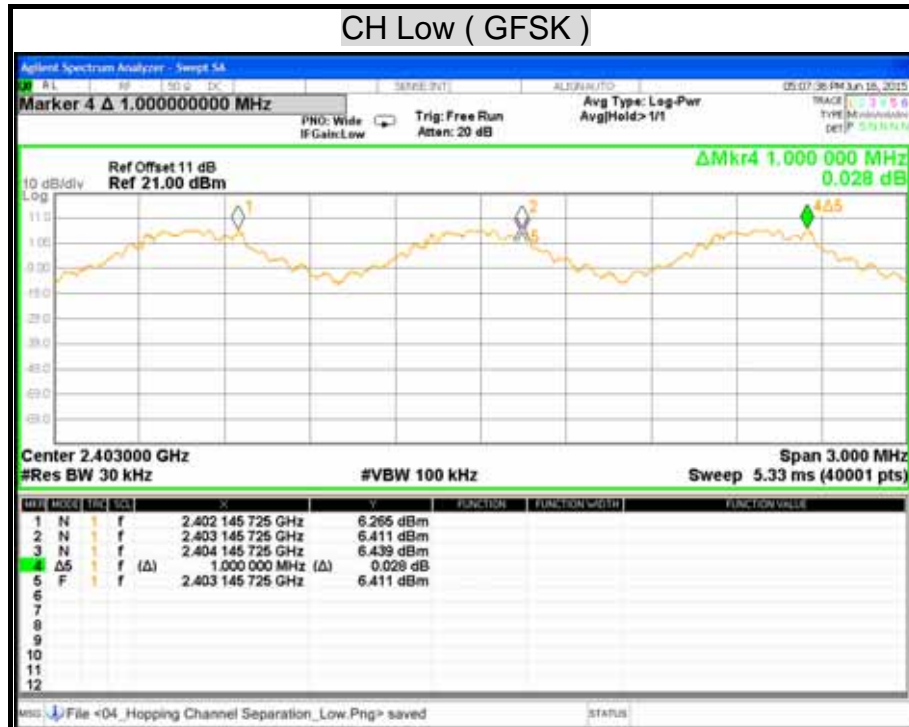

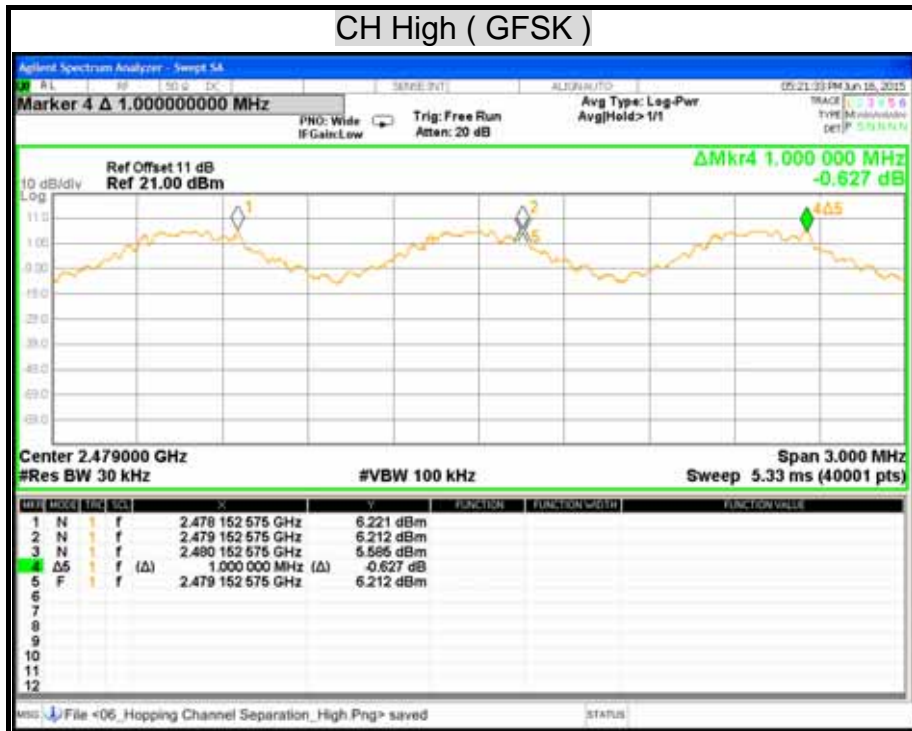

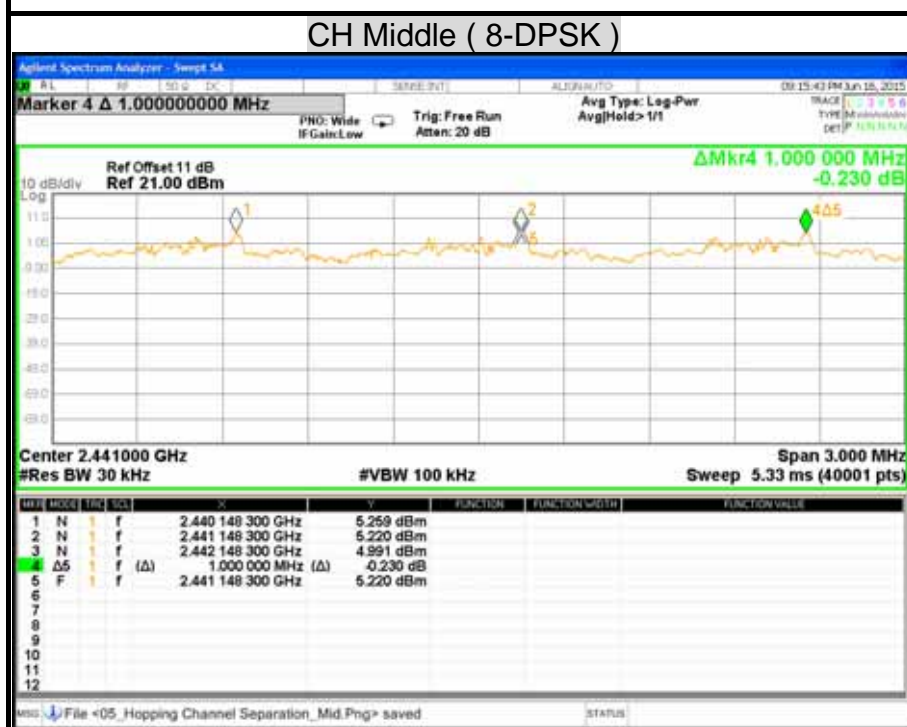
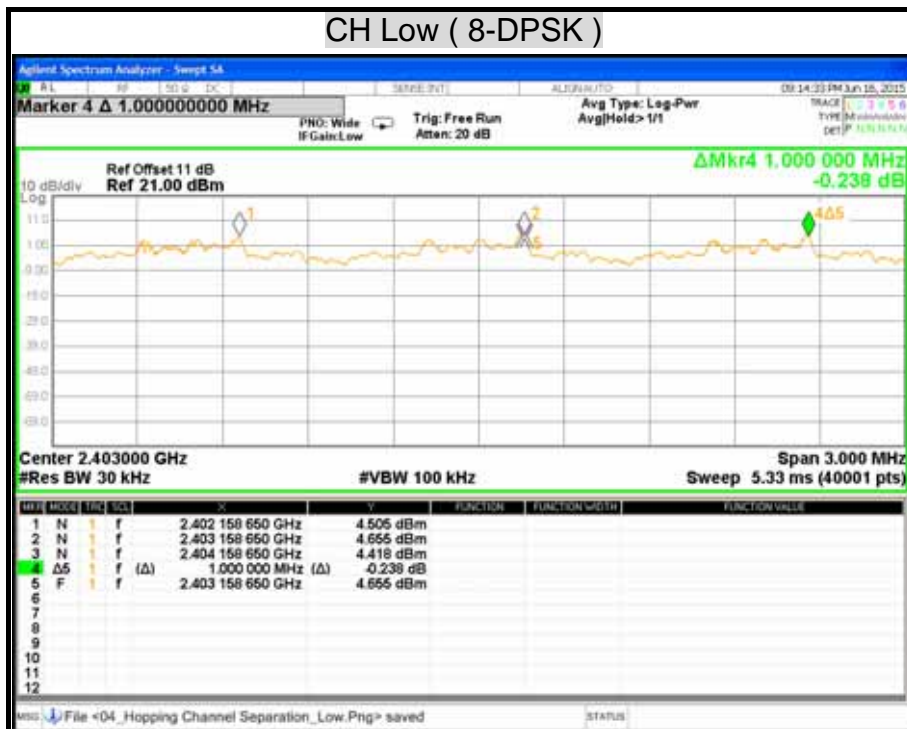

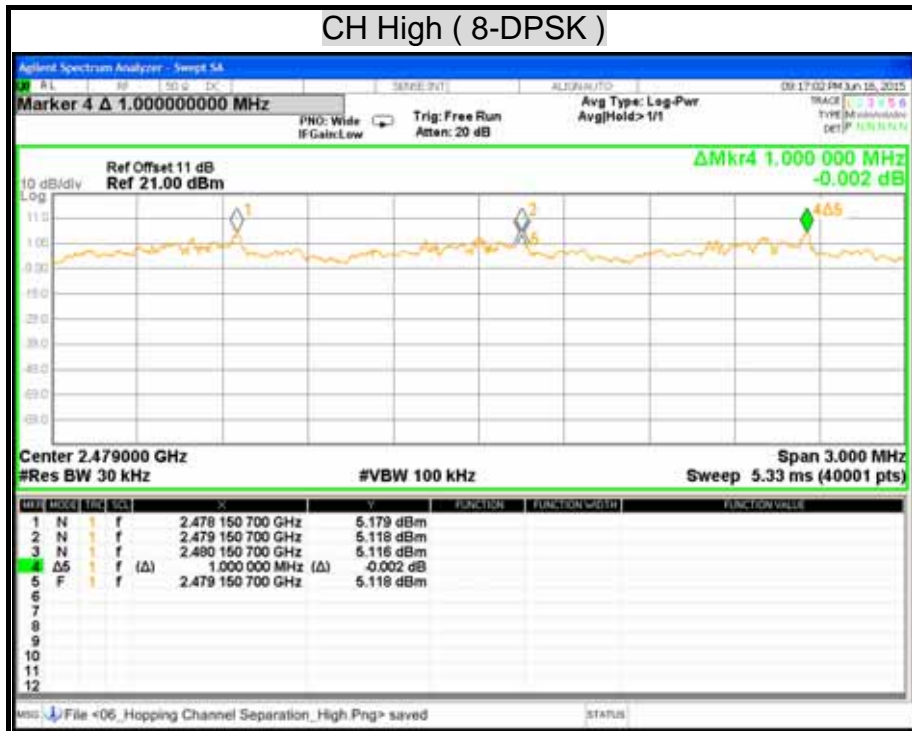

## 7.6 NUMBER OF HOPPING FREQUENCY USED

### LIMITS

§15.247(a)(1)(iii) For frequency hopping systems in the 2400-2483.5 MHz band shall use at least 15 channels.

### TEST EQUIPMENT

| Name of Equipment   | Manufacturer | Model  | Serial Number | Calibration Due |
|---------------------|--------------|--------|---------------|-----------------|
| EXA Signal Analyzer | Agilent      | N9010A | MY52220817    | 03/19/2016      |

*Remark: Each piece of equipment is scheduled for calibration once a year.*

### TEST SETUP



### TEST PROCEDURE

1. Check the calibration of the measuring instrument (spectrum analyzer) using either an internal calibrator or a known signal from an external generator.
2. Position the EUT as shown in test setup without connection to measurement instrument. Turn on the EUT and connect its antenna terminal to measurement instrument via a low loss cable. Then set it to any one measured frequency within its operating range and make sure the instrument is operated in its linear range.
3. Set the spectrum analyzer on MaxHold Mode, and then keep the EUT in hopping mode. Record all the signals from each channel until each one has been recorded.
4. Set the spectrum analyzer on View mode and then plot the result on spectrum analyzer screen.
5. Span = the frequency band of operation.
6. RBW  $\geq$  1% of the span.
7. VBW  $\geq$  RBW.
8. Sweep = auto.
9. Repeat above procedures until all frequencies measured were complete.

### TEST RESULTS

Refer to the attached plot.  
 There are 79 hopping frequencies in a hopping sequence.

**NUMBER OF HOPPING FREQUENCY USED**

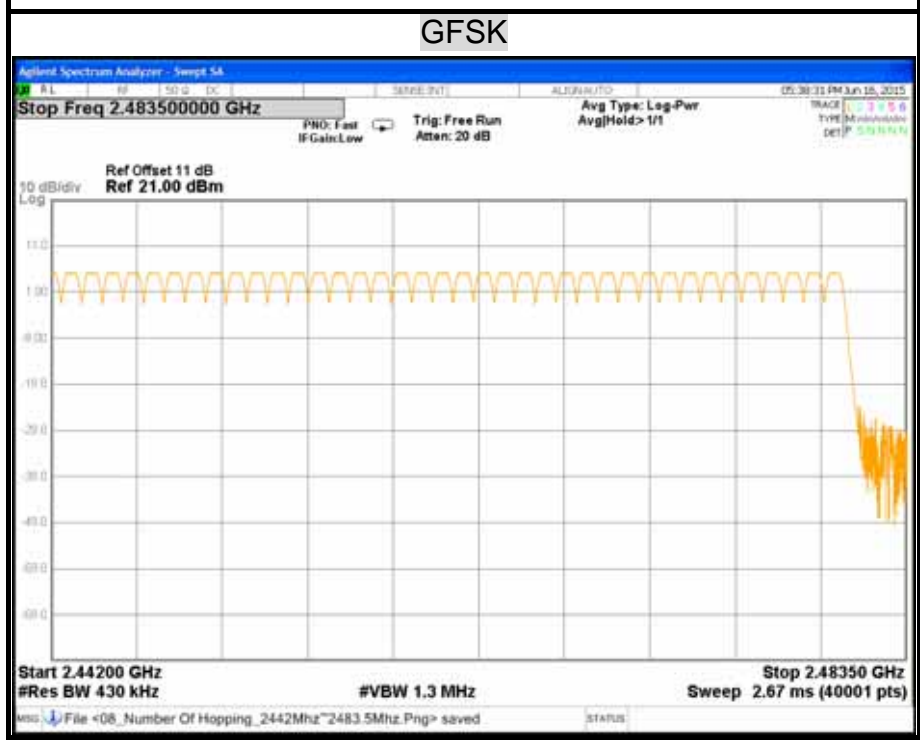
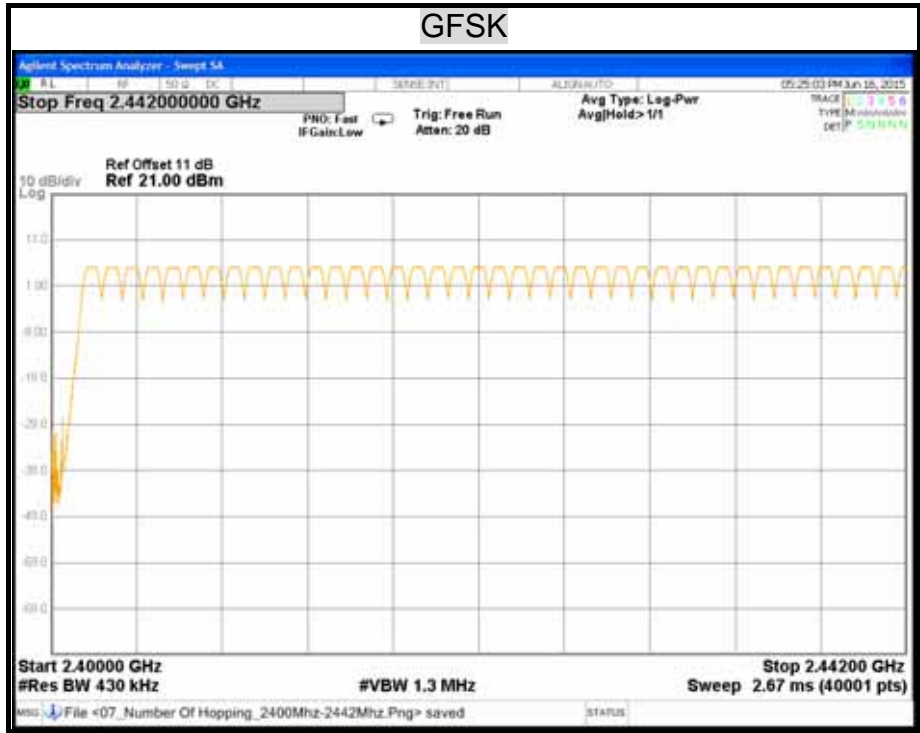

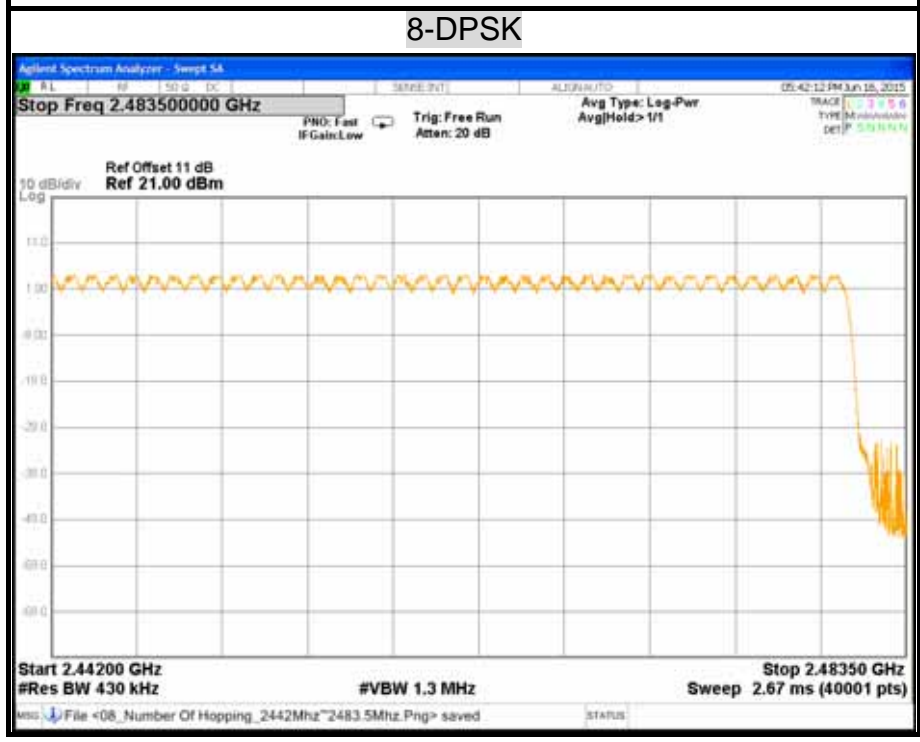
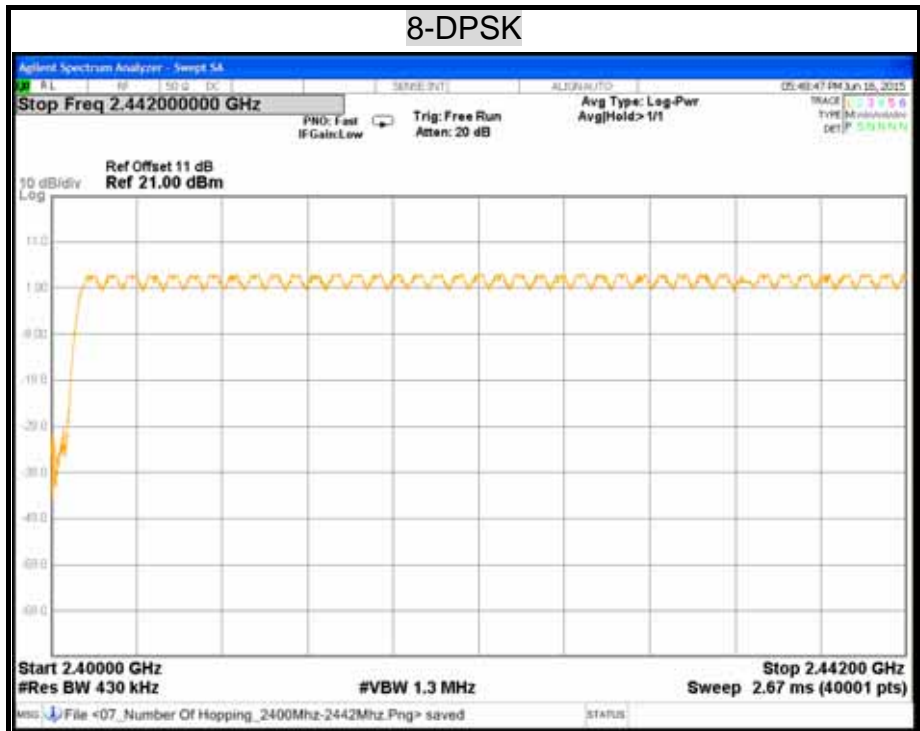

## 7.7 DWELL TIME ON EACH CHANNEL

### LIMITS

§15.247(a)(1)(iii) For frequency hopping system operating in the 2400-2483.5MHz band, the average time of occupancy on any frequency shall not be greater than 0.4 second within a 31.6 second period.

### TEST EQUIPMENT

| Name of Equipment   | Manufacturer | Model  | Serial Number | Calibration Due |
|---------------------|--------------|--------|---------------|-----------------|
| EXA Signal Analyzer | Agilent      | N9010A | MY52220817    | 03/19/2016      |

*Remark: Each piece of equipment is scheduled for calibration once a year.*

### TEST SETUP



### TEST PROCEDURE

1. Check the calibration of the measuring instrument using either an internal calibrator or a known signal from an external generator.
2. Position the EUT as shown in test setup without connection to measurement instrument. Turn on the EUT and connect its antenna terminal to measurement instrument via a low loss cable. Then set it to any one measured frequency within its operating range and make sure the instrument is operated in its linear range.
3. Adjust the center frequency of spectrum analyzer on any frequency be measured and set spectrum analyzer to zero span mode.
4. RBW = 1 MHz.
5. VBW ≥ RBW.
6. Sweep = as necessary to capture the entire dwell time per hopping channel.
7. Measure the time duration of one transmission on the measured frequency. And then plot the result with time difference of this time duration.
8. Repeat above procedures until all frequencies measured were complete.
9. The EUT has 3 type of payload, DH1, DH3, DH5. The hopping rate is 1600 per second. The longer the payload is, the slower the hopping rate is.



**TEST RESULTS**

Time of occupancy on the TX channel in 31.6sec = time domain slot length × hop rate ÷ number of hop per channel × 31.6

Refer to the attached graph.

The hopping rates of Bluetooth devices change with different types of payload. The longer the payload is, the slower the hopping rate. The hopping rate scenario is defined in Bluetooth core specification.

Modulation Type: GFSK

| Channel | Channel Frequency (MHz) | Packet type | Dwell time (ms) | Time of occupancy on the TX channel in 31.6sec (ms) | Limit for Time of occupancy on the TX channel in 31.6sec (ms) | Results |
|---------|-------------------------|-------------|-----------------|---|---|---------|
| Low     | 2402                    | DH1         | 0.368           | 117.86  | 400   | PASS    |
|         | 2402                    | DH3         | 1.620           | 259.20  | 400   | PASS    |
|         | 2402                    | DH5         | 2.870           | 306.13  | 400   | PASS    |
| Middle  | 2441                    | DH1         | 0.368           | 117.86  | 400   | PASS    |
|         | 2441                    | DH3         | 1.620           | 259.20  | 400   | PASS    |
|         | 2441                    | DH5         | 2.870           | 306.13  | 400   | PASS    |
| High    | 2480                    | DH1         | 0.368           | 117.86  | 400   | PASS    |
|         | 2480                    | DH3         | 1.620           | 259.20  | 400   | PASS    |
|         | 2480                    | DH5         | 2.870           | 306.13  | 400   | PASS    |

**Remark:**

*Ch Low*

*DH1 : 0.368 ms × ( 1600÷2 ) ÷ 79 × 31.6 = 117.86 (ms)*

*DH3 : 1.620 ms × ( 1600÷4 ) ÷ 79 × 31.6 = 259.20 (ms)*

*DH5 : 2.870 ms × ( 1600÷6 ) ÷ 79 × 31.6 = 306.13 (ms)*

*Ch Middle*

*DH1 : 0.368 ms × ( 1600÷2 ) ÷ 79 × 31.6 = 117.86 (ms)*

*DH3 : 1.620 ms × ( 1600÷4 ) ÷ 79 × 31.6 = 259.20 (ms)*

*DH5 : 2.870 ms × ( 1600÷6 ) ÷ 79 × 31.6 = 306.13 (ms)*

*Ch High*

*DH1 : 0.368 ms × ( 1600÷2 ) ÷ 79 × 31.6 = 117.86 (ms)*

*DH3 : 1.620 ms × ( 1600÷4 ) ÷ 79 × 31.6 = 259.20 (ms)*

*DH5 : 2.870 ms × ( 1600÷6 ) ÷ 79 × 31.6 = 306.13 (ms)*

Modulation Type: 8-DPSK

| Channel | Channel Frequency (MHz) | Packet type | Dwell time (ms) | Time of occupancy on the TX channel in 31.6sec (ms) | Limit for Time of occupancy on the TX channel in 31.6sec (ms) | Results |
|---------|-------------------------|-------------|-----------------|---|---|---------|
| Low     | 2402                    | DH1         | 0.368           | 117.86  | 400   | PASS    |
|         | 2402                    | DH3         | 1.620           | 259.20  | 400   | PASS    |
|         | 2402                    | DH5         | 2.870           | 306.13  | 400   | PASS    |
| Middle  | 2441                    | DH1         | 0.368           | 117.86  | 400   | PASS    |
|         | 2441                    | DH3         | 1.620           | 259.20  | 400   | PASS    |
|         | 2441                    | DH5         | 2.870           | 306.13  | 400   | PASS    |
| High    | 2480                    | DH1         | 0.368           | 117.86  | 400   | PASS    |
|         | 2480                    | DH3         | 1.620           | 259.20  | 400   | PASS    |
|         | 2480                    | DH5         | 2.870           | 306.13  | 400   | PASS    |

**Remark:**

*Ch Low*

*DH1 :  $0.368 \text{ ms} \times ( 1600 \div 2 ) \div 79 \times 31.6 = 117.86 \text{ (ms)}$*

*DH3 :  $1.620 \text{ ms} \times ( 1600 \div 4 ) \div 79 \times 31.6 = 259.20 \text{ (ms)}$*

*DH5 :  $2.870 \text{ ms} \times ( 1600 \div 6 ) \div 79 \times 31.6 = 306.13 \text{ (ms)}$*

*Ch Middle*

*DH1 :  $0.368 \text{ ms} \times ( 1600 \div 2 ) \div 79 \times 31.6 = 117.86 \text{ (ms)}$*

*DH3 :  $1.620 \text{ ms} \times ( 1600 \div 4 ) \div 79 \times 31.6 = 259.20 \text{ (ms)}$*

*DH5 :  $2.870 \text{ ms} \times ( 1600 \div 6 ) \div 79 \times 31.6 = 306.13 \text{ (ms)}$*

*Ch High*

*DH1 :  $0.368 \text{ ms} \times ( 1600 \div 2 ) \div 79 \times 31.6 = 117.86 \text{ (ms)}$*

*DH3 :  $1.620 \text{ ms} \times ( 1600 \div 4 ) \div 79 \times 31.6 = 259.20 \text{ (ms)}$*

*DH5 :  $2.870 \text{ ms} \times ( 1600 \div 6 ) \div 79 \times 31.6 = 306.13 \text{ (ms)}$*

**DWELL TIME ON EACH PAYLOAD**

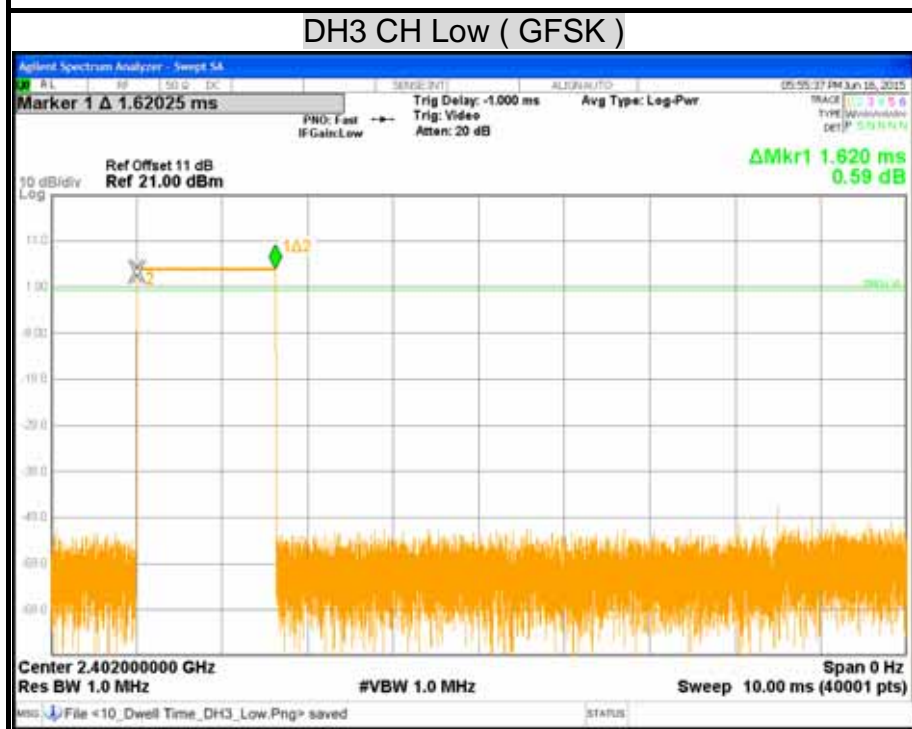
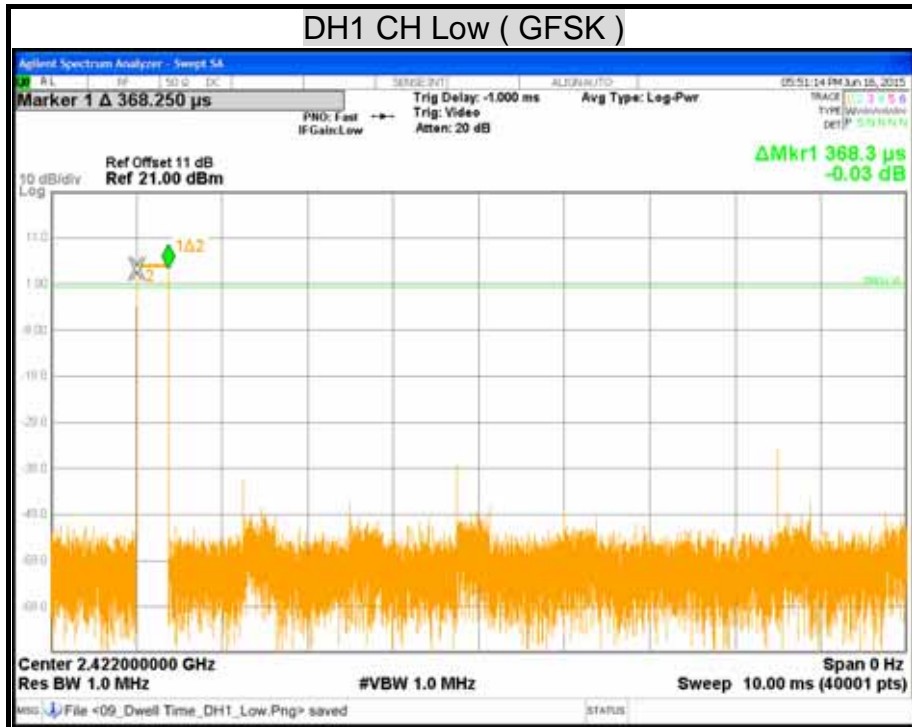

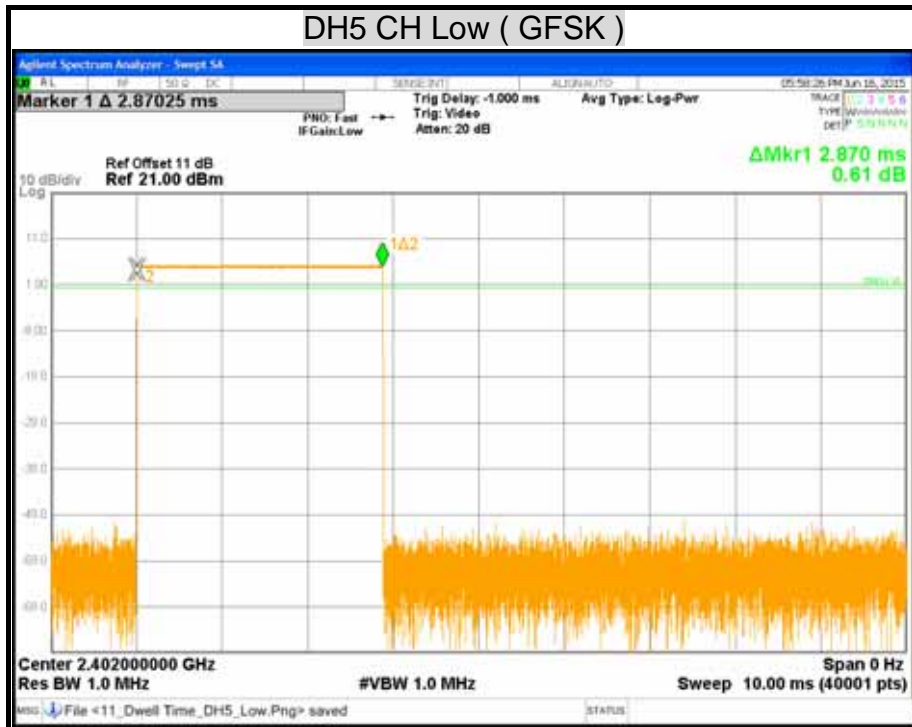

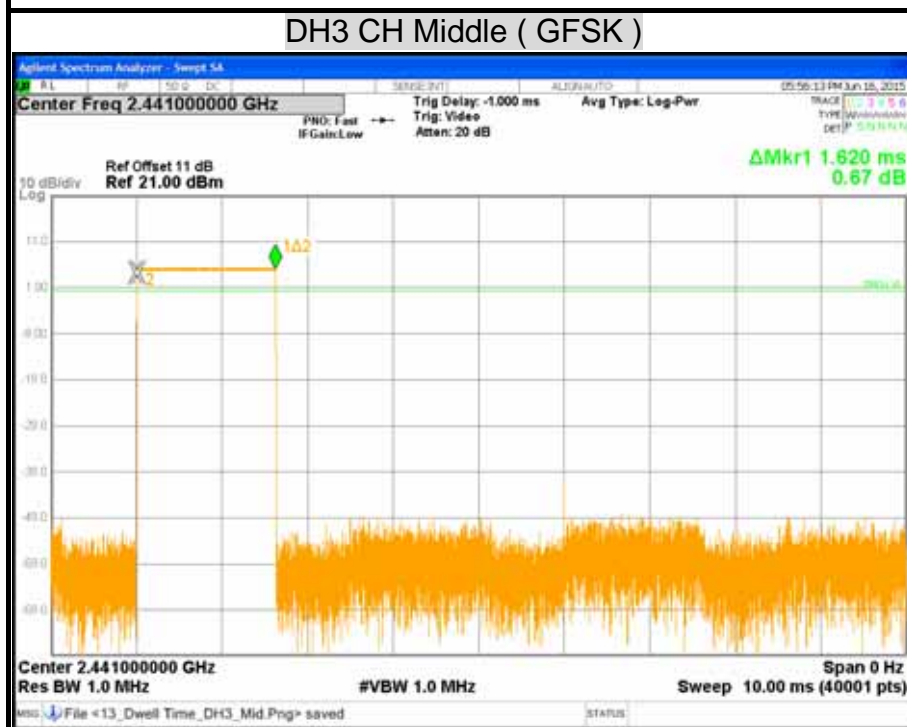
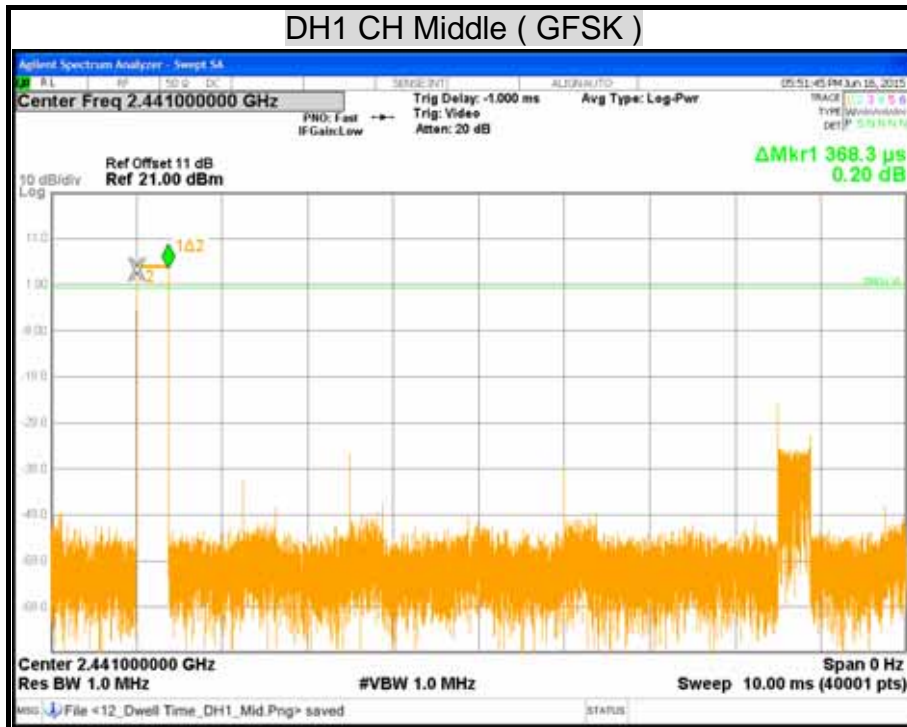

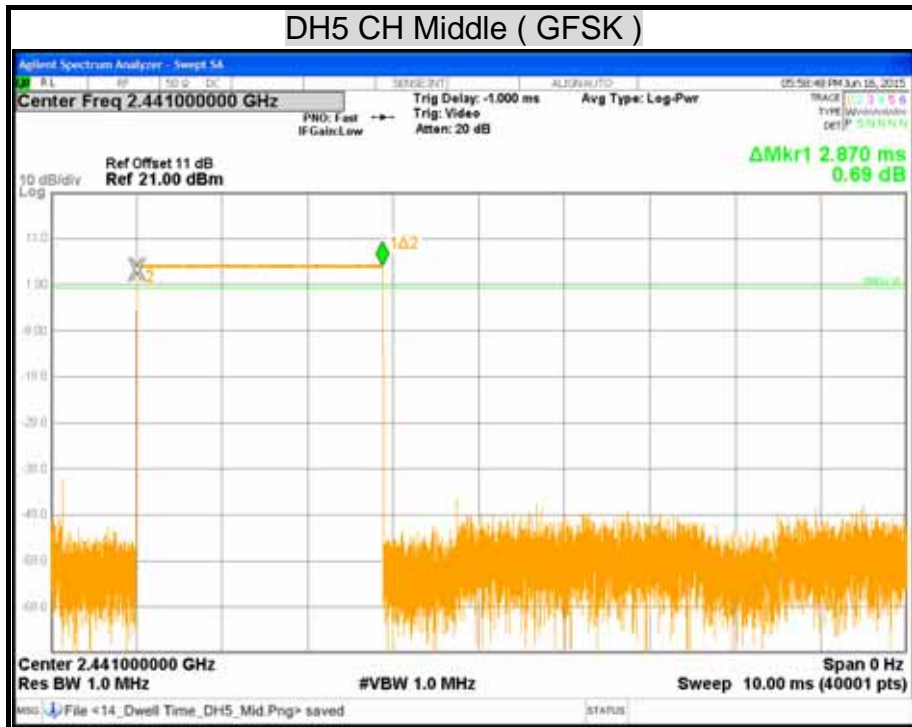

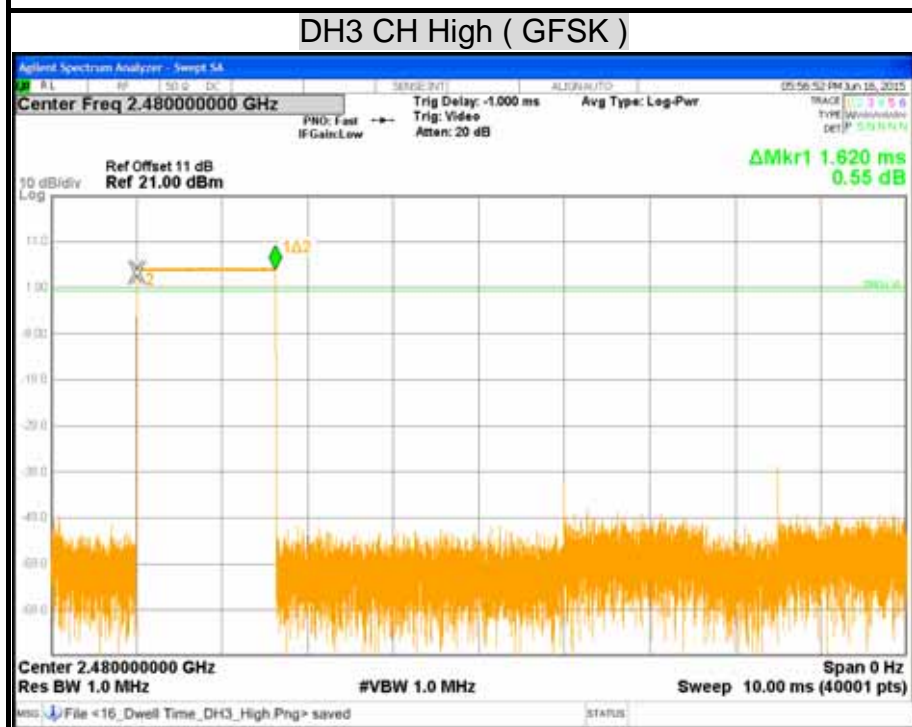
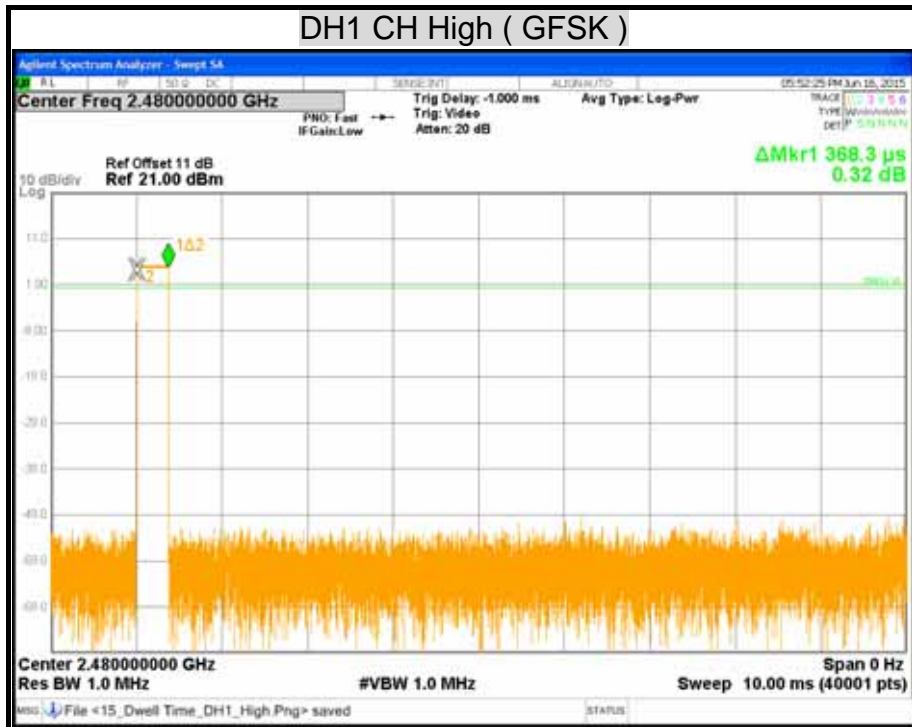





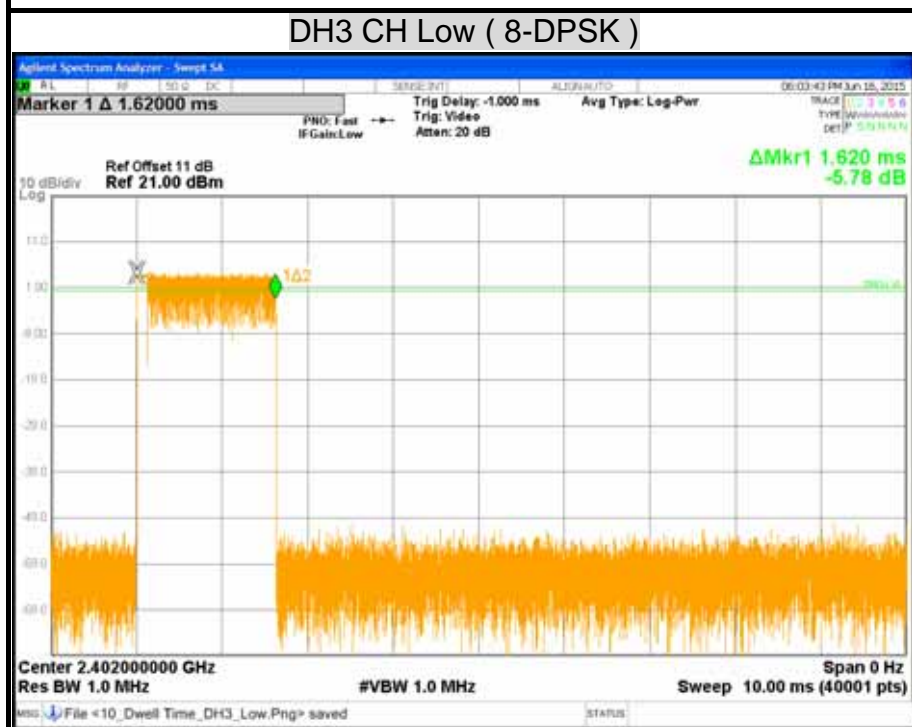
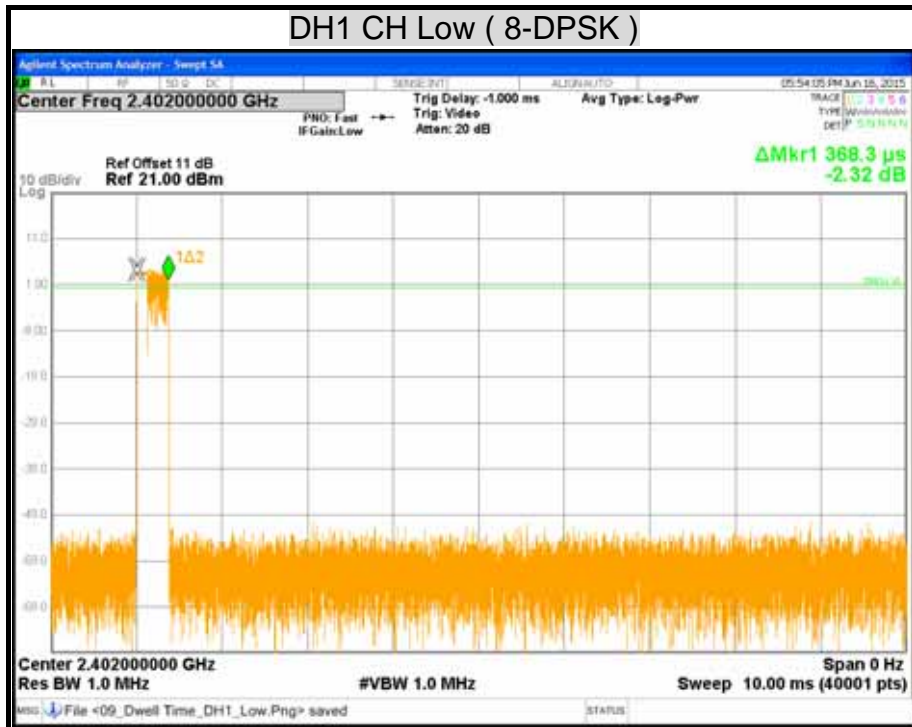

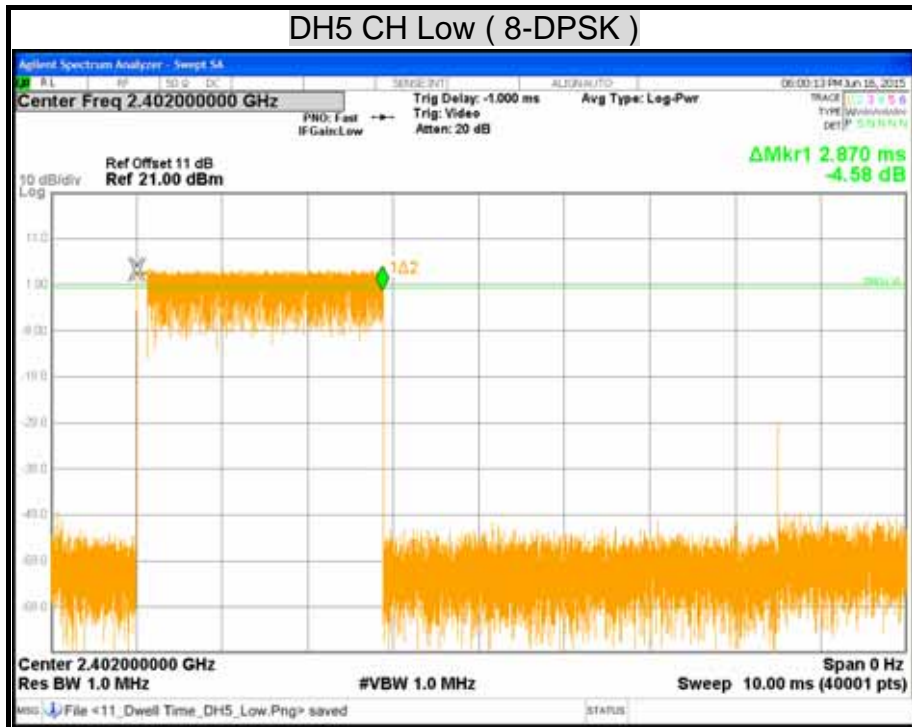

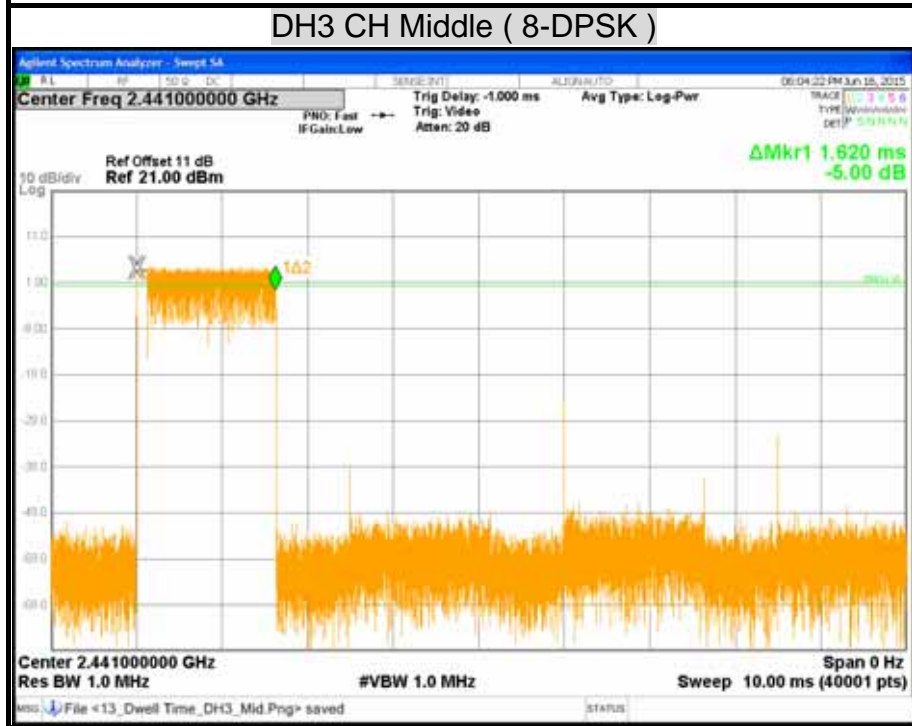
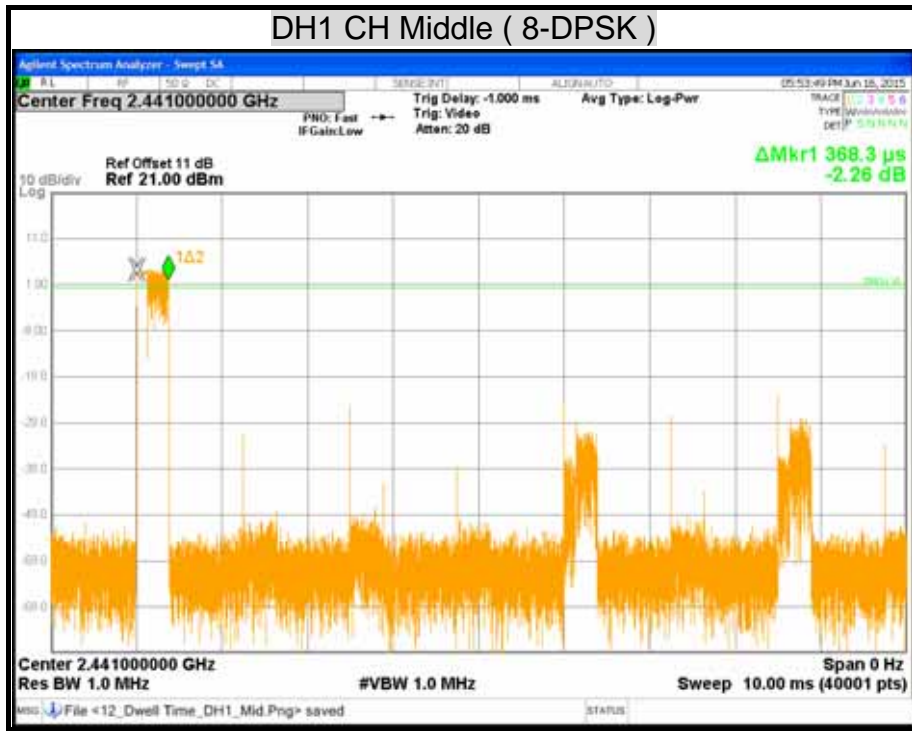

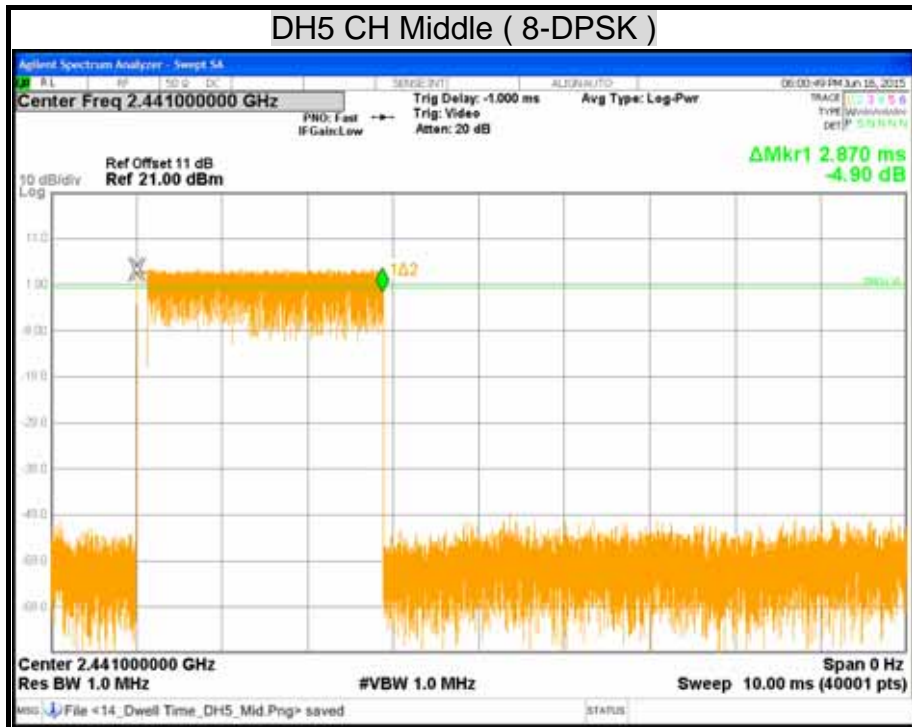

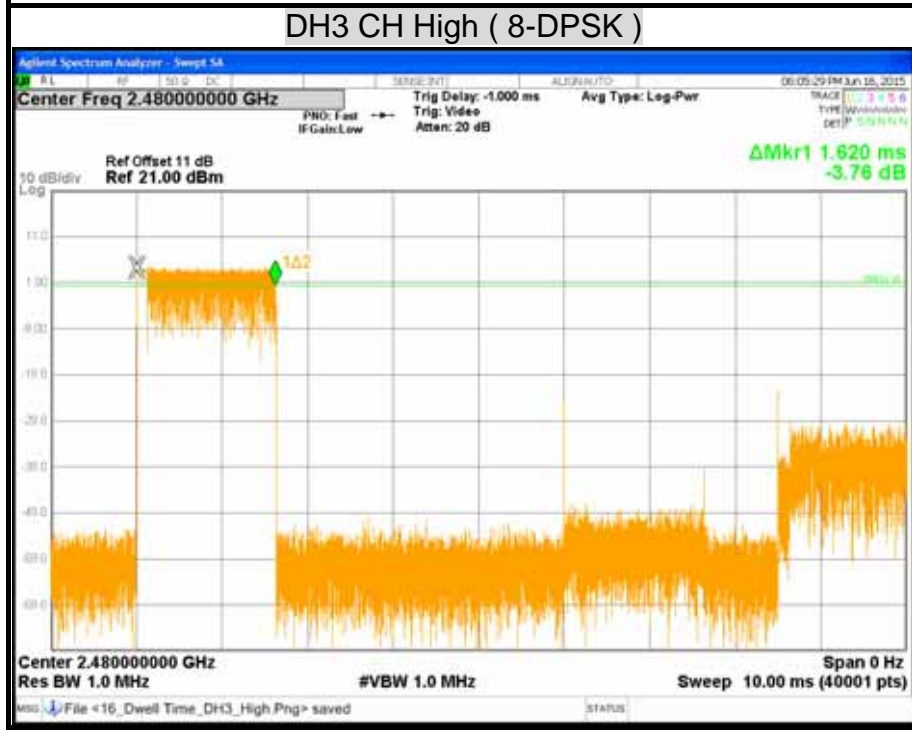
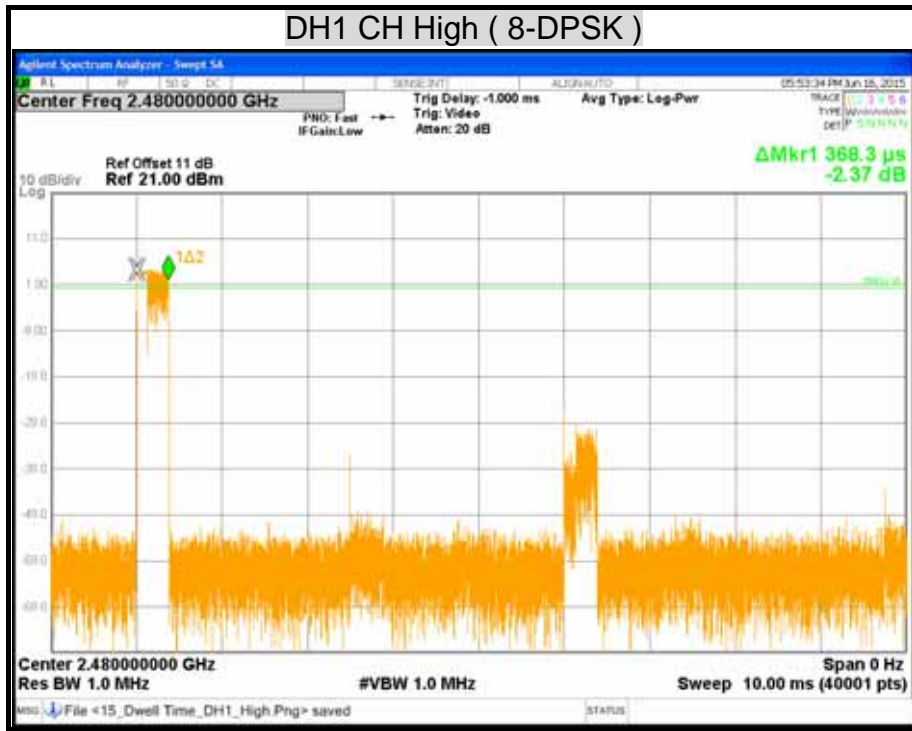

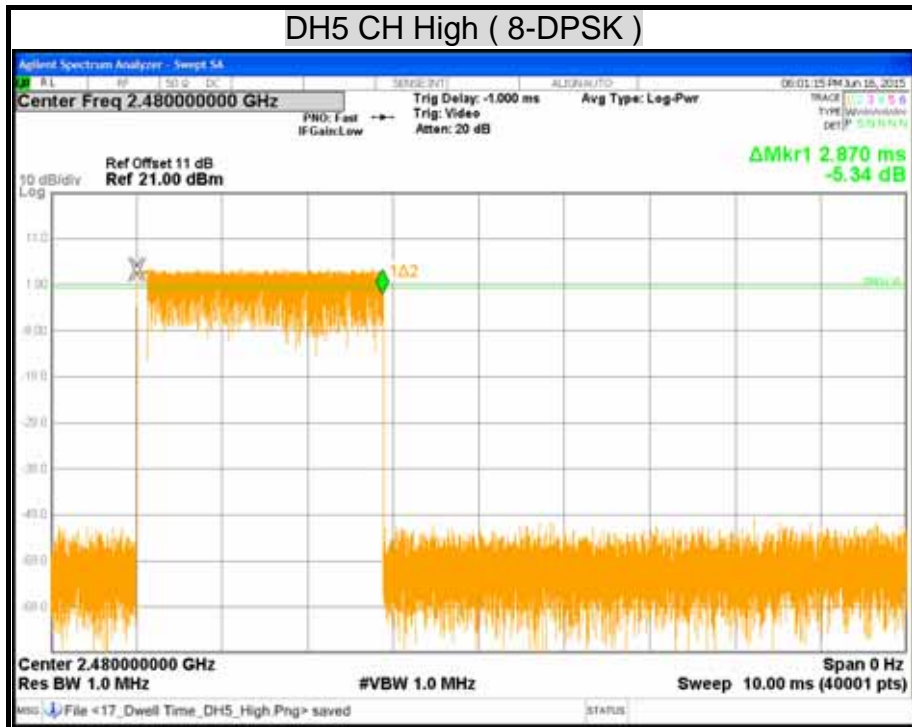

## 7.8 CONDUCTED SPURIOUS EMISSION

### LIMITS

§ 15.247(d) In any 100 kHz bandwidth outside the frequency band in which the spread spectrum intentional radiator is operating, the radio frequency power that is produced by the intentional radiator shall be at least 20 dB below that in the 100 kHz bandwidth within the and that contains the highest level of the desired power, based on either an RF conducted or a radiated measurement. Attenuation below the general limits specified in § 15.209(a) is not required. In addition, radiated emissions which fall in the restricted bands, as defined in § 15.205(a), must also comply with the radiated emission limits specified in § 15.209(a) (see § 15.205(c)).

### TEST EQUIPMENT

| Name of Equipment   | Manufacturer | Model  | Serial Number | Calibration Due |
|---------------------|--------------|--------|---------------|-----------------|
| EXA Signal Analyzer | Agilent      | N9010A | MY52220817    | 03/19/2016      |

*Remark: Each piece of equipment is scheduled for calibration once a year.*

### TEST SETUP



### TEST PROCEDURE

The transmitter output is connected to a spectrum analyzer. The resolution bandwidth is set to 100 kHz. The video bandwidth is set to 300 kHz.

The spectrum from 30 MHz to 26.5 GHz is investigated with the transmitter set to the lowest, middle, and highest channels in the 2.4 GHz band.

**TEST RESULTS**

**OUT-OF-BAND SPURIOUS EMISSIONS-CONDUCTED MEASUREMENT**

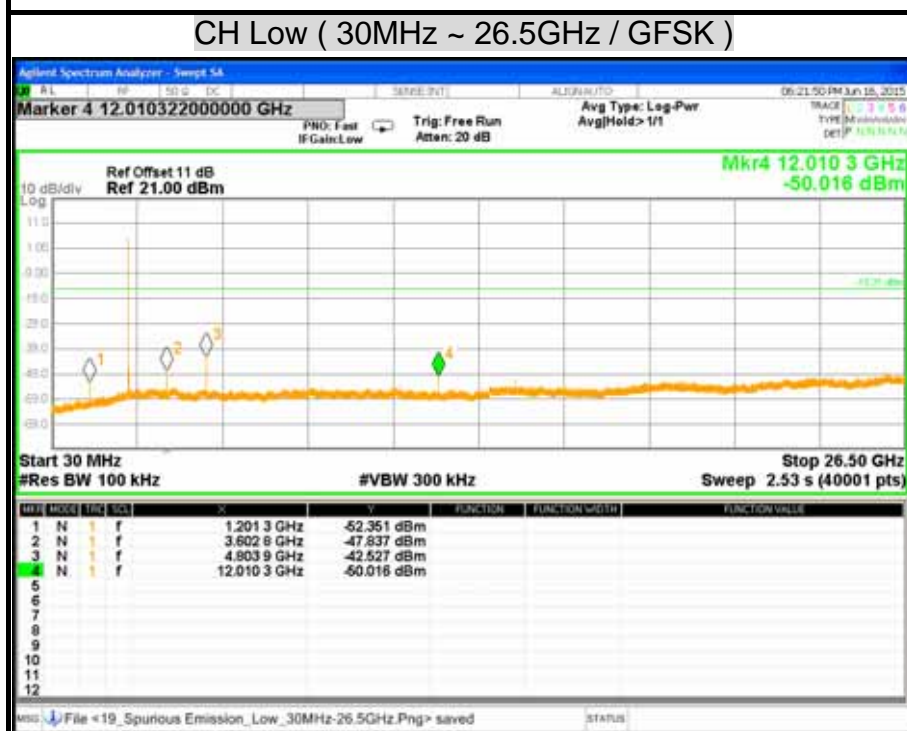
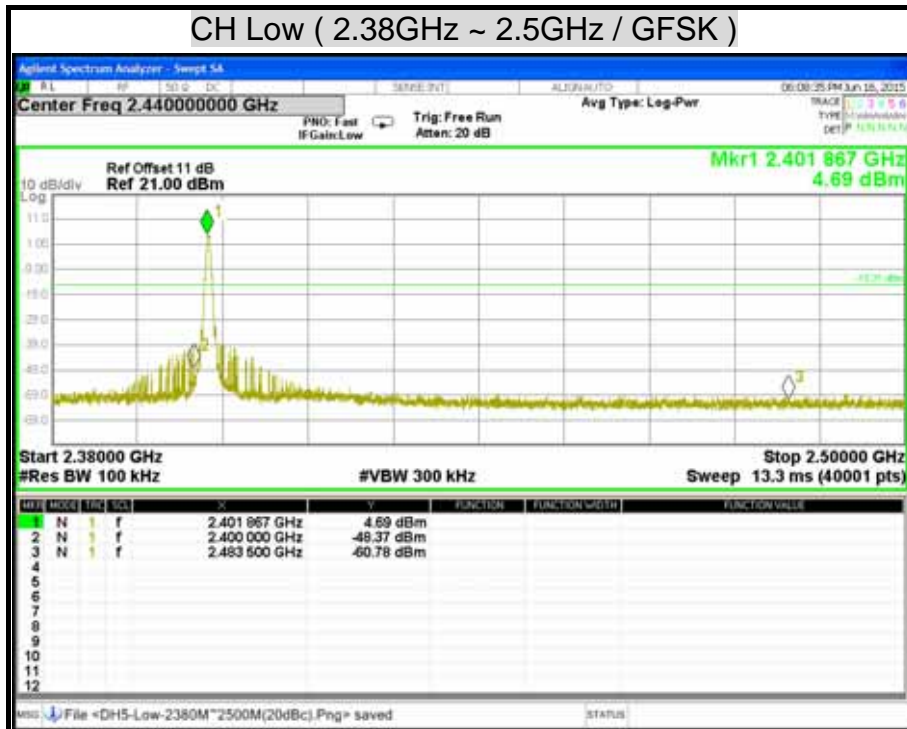



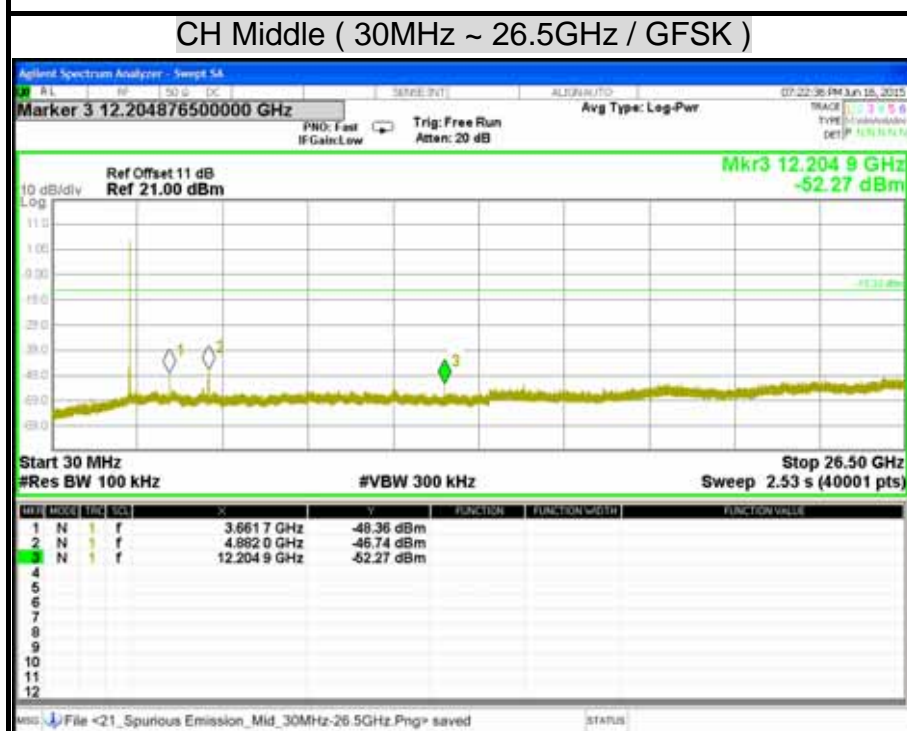
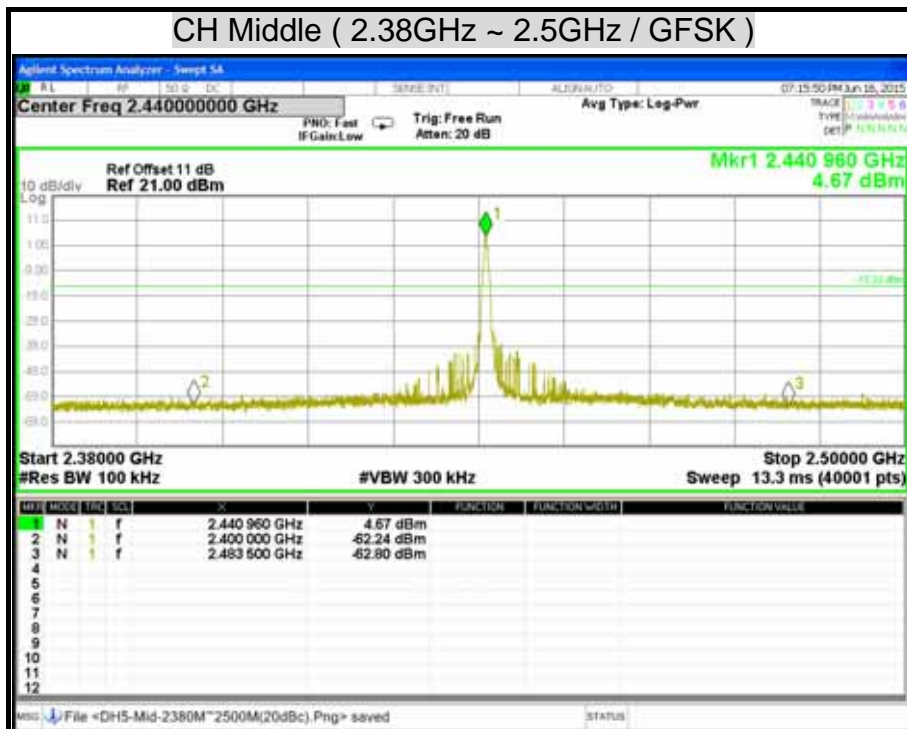

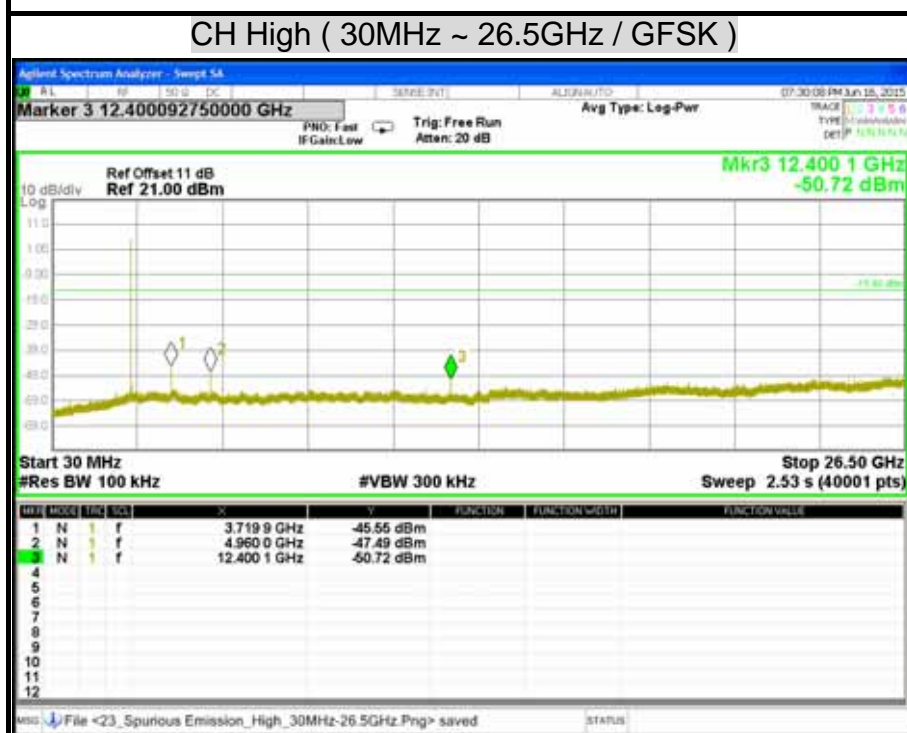
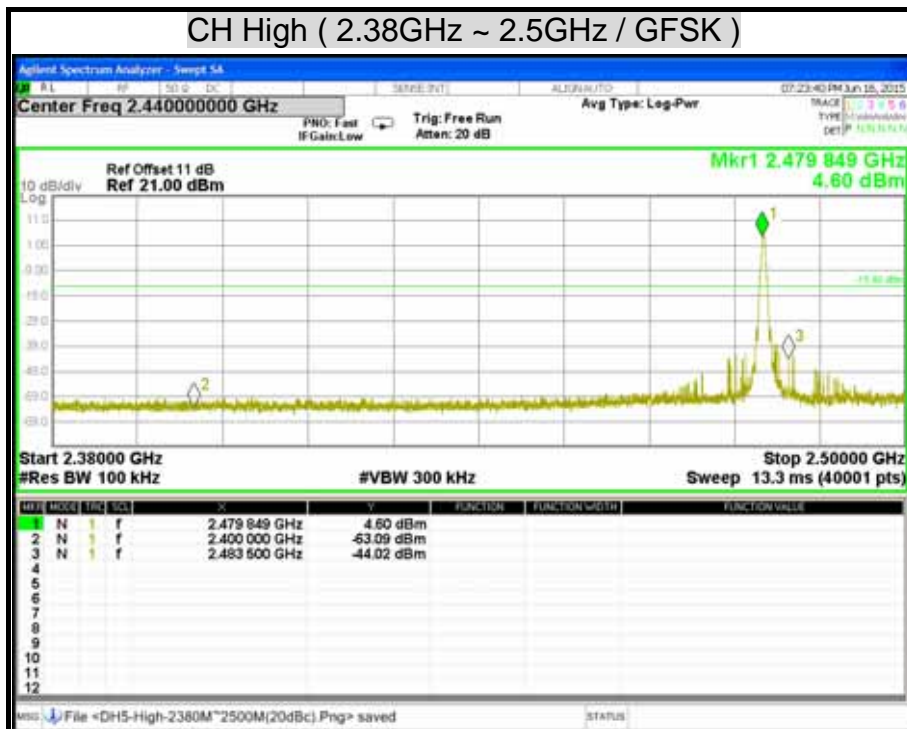

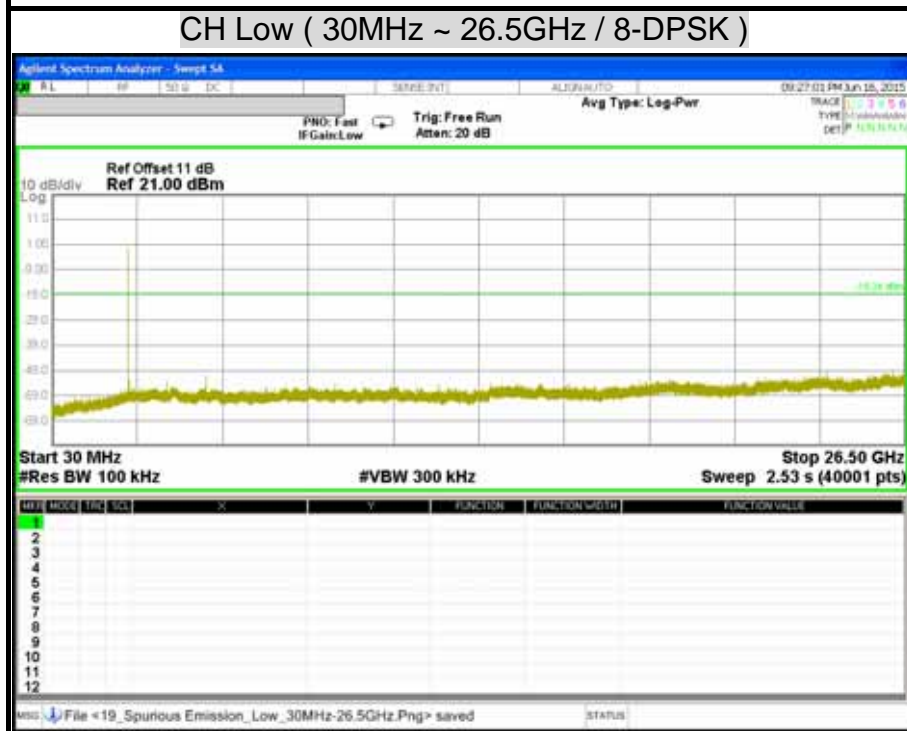
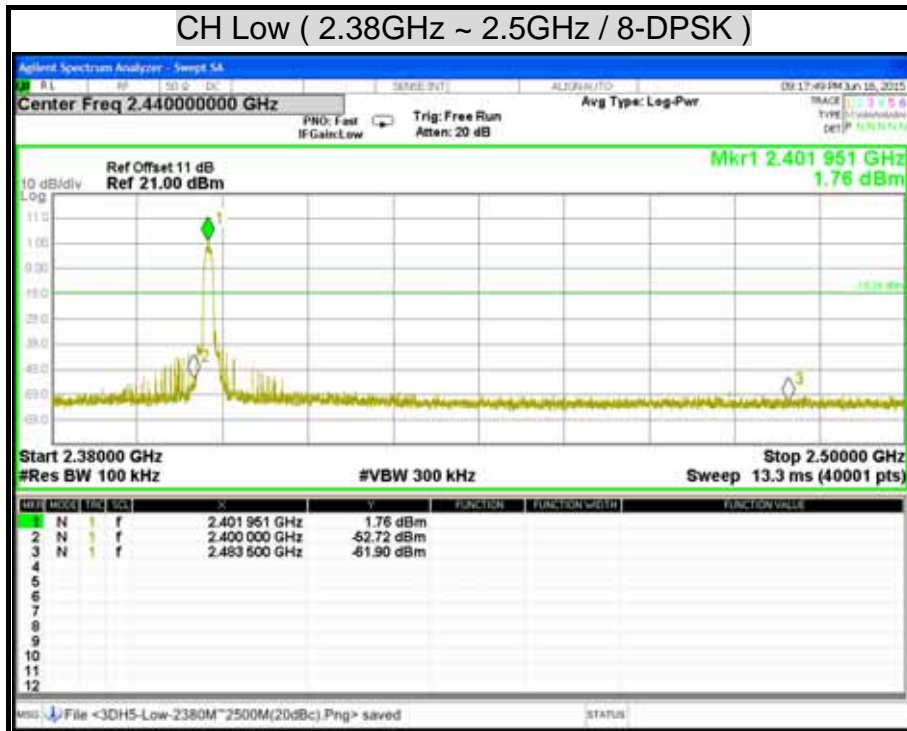

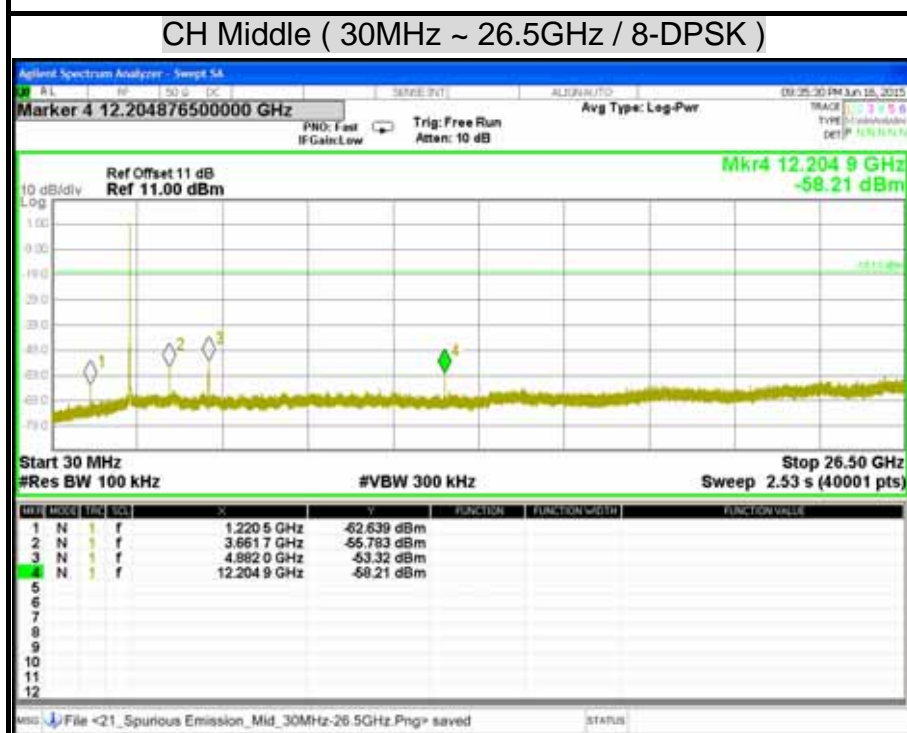
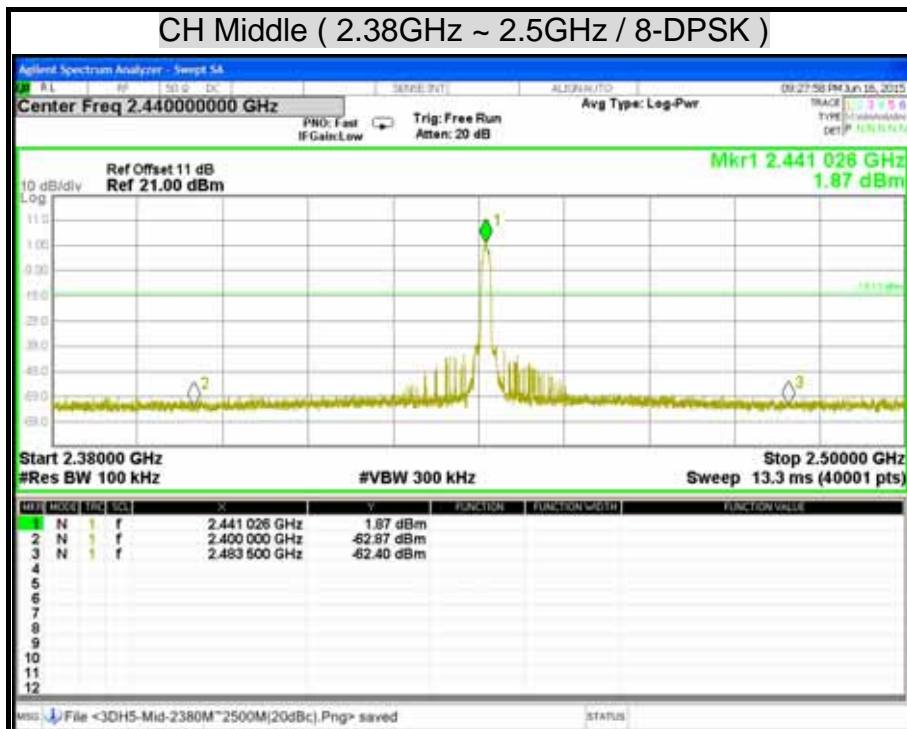

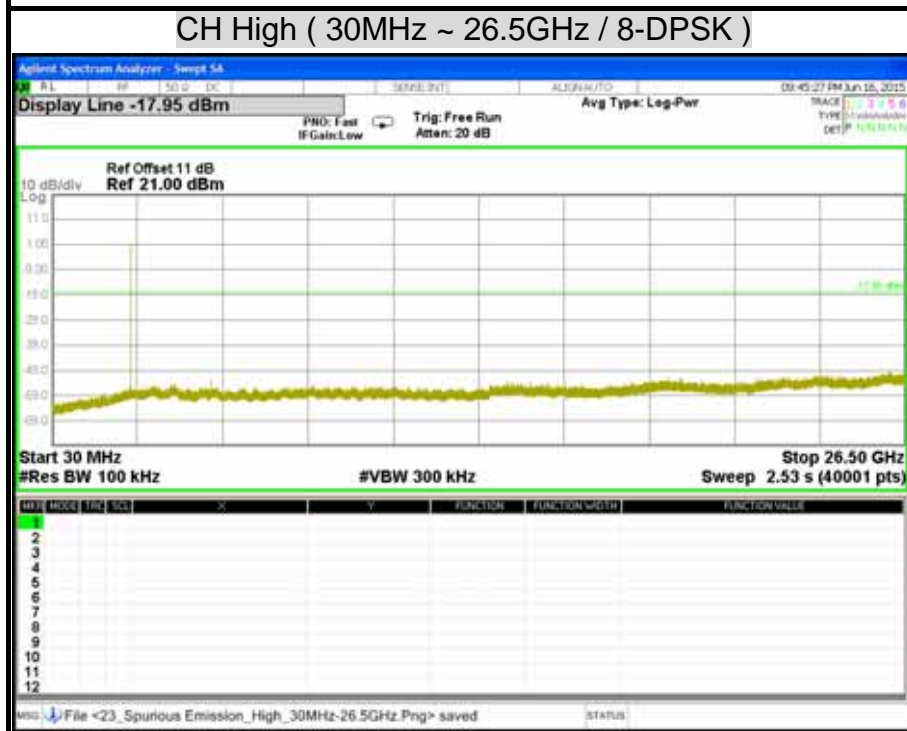
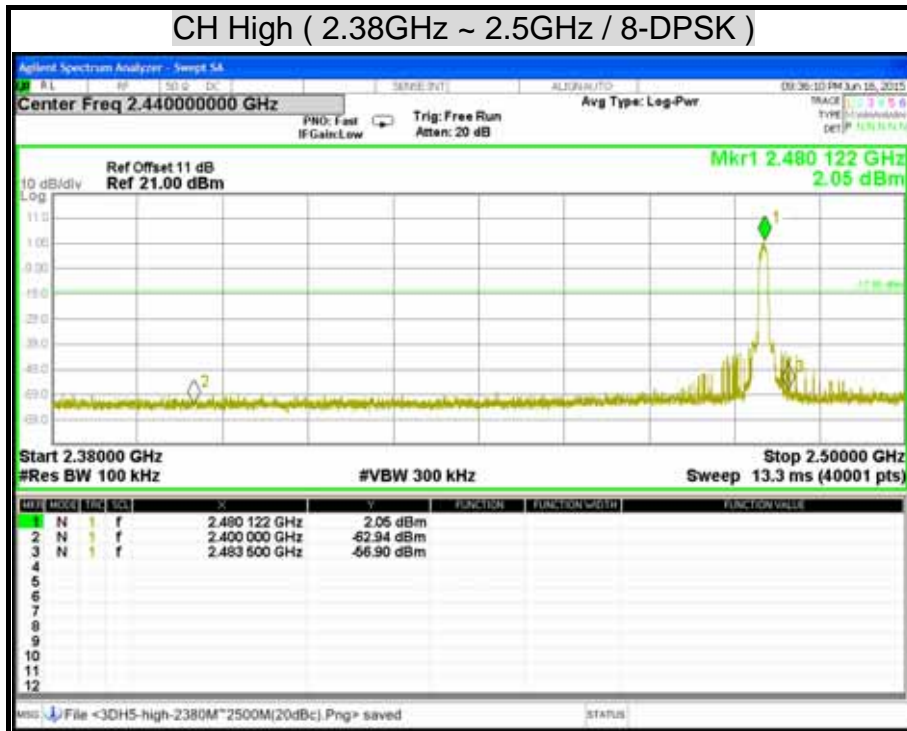

**CONDUCTED MEASUREMENT HOPPING BAND EDGES**

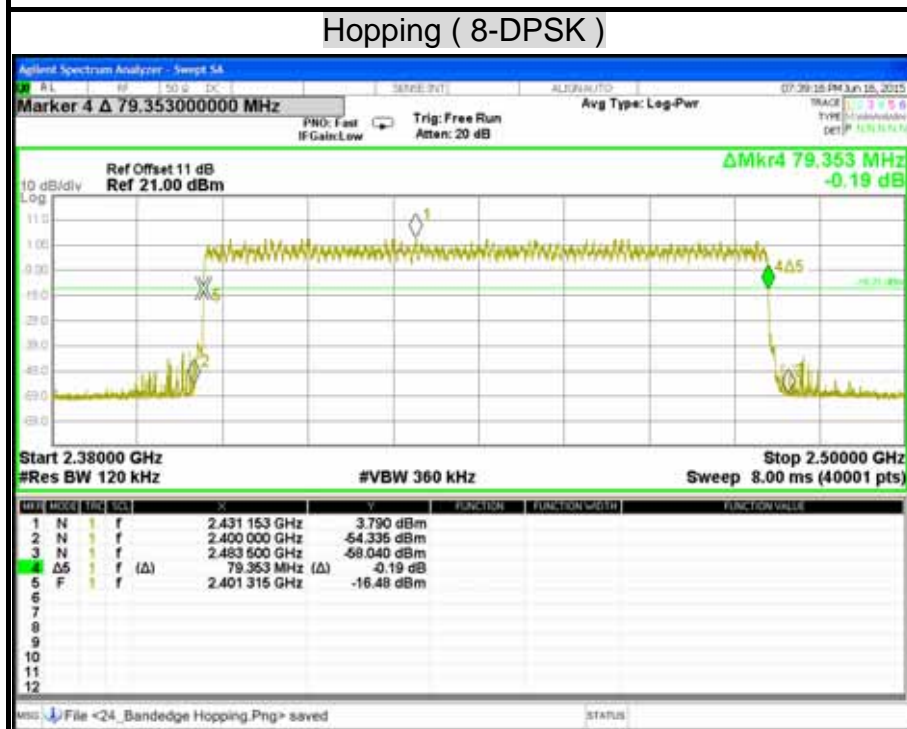
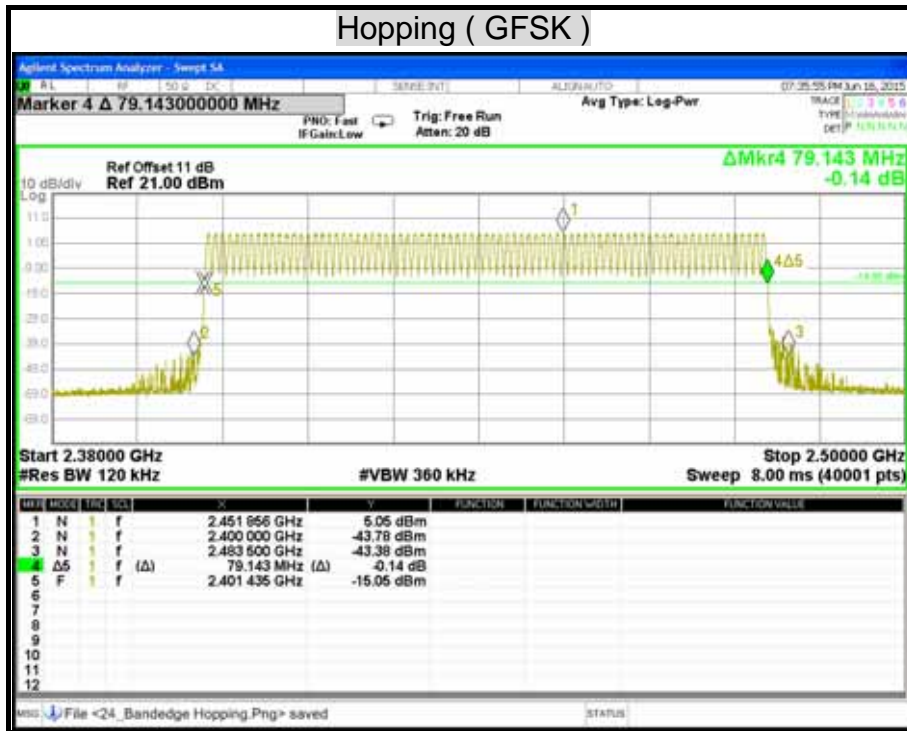

## 7.9 RADIATED EMISSION

### LIMITS

(1) According to § 15.205 (a) Except as shown in paragraph (d) of this section, only spurious emissions are permitted in any of the frequency bands listed below:

| MHz                        | MHz                      | MHz             | GHz              |
|----------------------------|--------------------------|-----------------|------------------|
| 0.090 - 0.110              | 16.42 - 16.423           | 399.9 - 410     | 4.5 - 5.15       |
| <sup>1</sup> 0.495 - 0.505 | 16.69475 - 16.69525      | 608 - 614       | 5.35 - 5.46      |
| 2.1735 - 2.1905            | 16.80425 - 16.80475      | 960 - 1240      | 7.25 - 7.75      |
| 4.125 - 4.128              | 25.5 - 25.67             | 1300 - 1427     | 8.025 - 8.5      |
| 4.17725 - 4.17775          | 37.5 - 38.25             | 1435 - 1626.5   | 9.0 - 9.2        |
| 4.20725 - 4.20775          | 73 - 74.6                | 1645.5 - 1646.5 | 9.3 - 9.5        |
| 6.215 - 6.218              | 74.8 - 75.2              | 1660 - 1710     | 10.6 - 12.7      |
| 6.26775 - 6.26825          | 108 - 121.94             | 1718.8 - 1722.2 | 13.25 - 13.4     |
| 6.31175 - 6.31225          | 123 - 138                | 2200 - 2300     | 14.47 - 14.5     |
| 8.291 - 8.294              | 149.9 - 150.05           | 2310 - 2390     | 15.35 - 16.2     |
| 8.362 - 8.366              | 156.52475 -<br>156.52525 | 2483.5 - 2500   | 17.7 - 21.4      |
| 8.37625 - 8.38675          | 156.7 - 156.9            | 2655 - 2900     | 22.01 - 23.12    |
| 8.41425 - 8.41475          | 162.0125 - 167.17        | 3260 - 3267     | 23.6 - 24.0      |
| 12.29 - 12.293             | 167.72 - 173.2           | 3332 - 3339     | 31.2 - 31.8      |
| 12.51975 - 12.52025        | 240 - 285                | 3345.8 - 3338   | 36.43 - 36.5     |
| 12.57675 - 12.57725        | 322 - 335.4              | 3600 - 4400     | ( <sup>2</sup> ) |
| 13.36 - 13.41              |                          |                 |                  |

**Remark:**

1. <sup>1</sup> Until February 1, 1999, this restricted band shall be 0.490-0.510 MHz.
2. <sup>2</sup> Above 38.6

(2) According to § 15.205 (b) Except as provided in paragraphs (d) and (e), the field strength of emissions appearing within these frequency bands shall not exceed the limits shown in Section 15.209. At frequencies equal to or less than 1000 MHz, compliance with the limits in Section 15.209 shall be demonstrated using measurement instrumentation employing a CISPR quasi-peak detector. Above 1000 MHz, compliance with the emission limits in Section 15.209 shall be demonstrated based on the average value of the measured emissions. The provisions in Section 15.35 apply to these measurements.

(3) According to § 15.209 (a) Except as provided elsewhere in this Subpart, the emissions from an intentional radiator shall not exceed the field strength levels specified in the following table :

| Frequency (MHz) | Field Strength (microvolts/meter) | Measurement Distance (meters) |
|-----------------|-----------------------------------|-------------------------------|
| 0.009 – 0.490   | 2400/F(KHz)                       | 300                           |
| 0.490 – 1.705   | 24000/F(KHz)                      | 30                            |
| 1.705 – 30.0    | 30                                | 30                            |
| 30 - 88         | 100 **                            | 3                             |
| 88 - 216        | 150 **                            | 3                             |
| 216 - 960       | 200 **                            | 3                             |
| Above 960       | 500                               | 3                             |

**Remark:** \*\*Except as provided in paragraph (g), fundamental emissions from intentional radiators operating under this Section shall not be located in the frequency bands 54-72 MHz, 76-88 MHz, 174-216 MHz or 470-806 MHz. However, operation within these frequency bands is permitted under other sections of this Part, e.g., Sections 15.231 and 15.241.

(4) According to § 15.209 (b) In the emission table above, the tighter limit applies at the band edges.

**TEST EQUIPMENT**

**Radiated Emission / 966Chamber\_B**

| Name of Equipment            | Manufacture     | Model       | Serial Number | Calibration Due |
|------------------------------|-----------------|-------------|---------------|-----------------|
| Spectrum Analyzer            | Agilent         | E4446A      | MY46180323    | 04/14/2016      |
| EMI Test Receiver            | ROHDE & SCHWARZ | ESCS 30     | 835418/008    | 10/14/2015      |
| Bi-log Antenna               | SCHWARZBECK     | VULB 9168   | 9168-250      | 08/21/2015      |
| Double-Ridged Waveguide Horn | ETS-LINDGREN    | 3117        | 00078733      | 12/02/2015      |
| Horn Antenna                 | COM-POWER       | AH-840      | 03077         | 12/17/2015      |
| Pre-Amplifier                | Agilent         | 8447D       | 2944A10052    | 07/15/2015      |
| Pre-Amplifier                | Agilent         | 8449B       | 3008A01916    | 07/15/2015      |
| LOOP Antenna                 | EMCO            | 6502        | 8905-2356     | 09/23/2015      |
| Notch Filters Band Reject    | Micro-Tronics   | BRM05702-01 | 026           | N.C.R           |

**Remark:** 1. Each piece of equipment is scheduled for calibration once a year.  
 2. N.C.R = No Calibration Request.



**Radiated Emission 966Chamber\_C**

| Name of Equipment            | Manufacture     | Model       | Serial Number | Calibration Due |
|------------------------------|-----------------|-------------|---------------|-----------------|
| Spectrum Analyzer            | Agilent         | E4446A      | MY45280064    | 03/26/2016      |
| EMI Test Receiver            | ROHDE & SCHWARZ | ESCI        | 101387        | 10/05/2015      |
| Bi-log Antenna               | TESEQ           | CBL 6112D   | 35404         | 02/24/2016      |
| Double-Ridged Waveguide Horn | ETS-LINDGREN    | 3117        | 00078732      | 07/23/2015      |
| Horn Antenna                 | COM-POWER       | AH-840      | 03077         | 12/17/2015      |
| Pre-Amplifier                | EMCI            | EMC001625   | 980243        | 04/12/2016      |
| Pre-Amplifier                | COM-POWER       | PAM-118A    | 551043        | 04/12/2016      |
| Notch Filters Band Reject    | Micro-Tronics   | BRM50702-01 | 009           | N.C.R           |

**Remark:** 1. Each piece of equipment is scheduled for calibration once a year.  
 2. N.C.R = No Calibration Request.

**TEST SETUP**

The diagram below shows the test setup that is utilized to make the measurements for emission below 1GHz.

**9kHz ~ 30MHz**

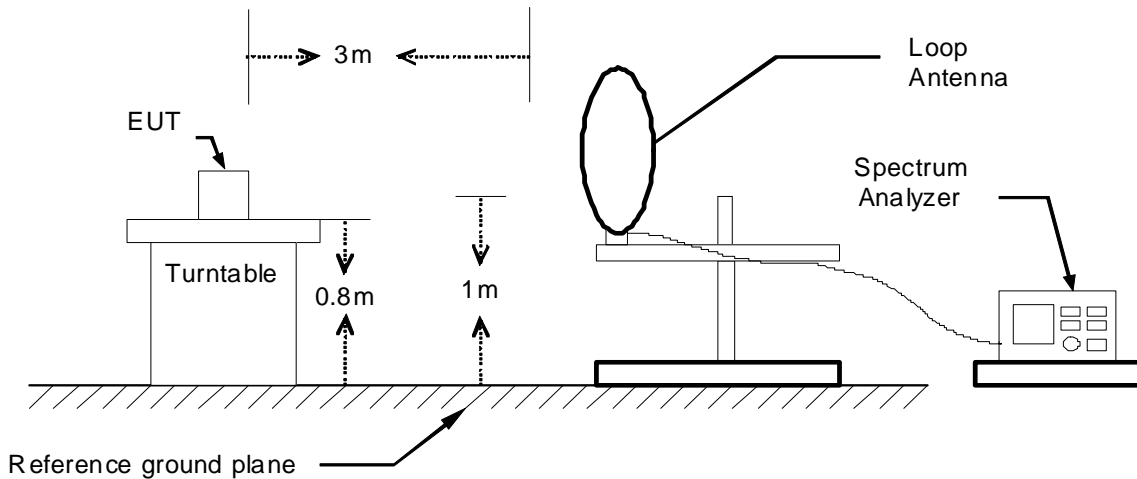

**30MHz ~ 1GHz**

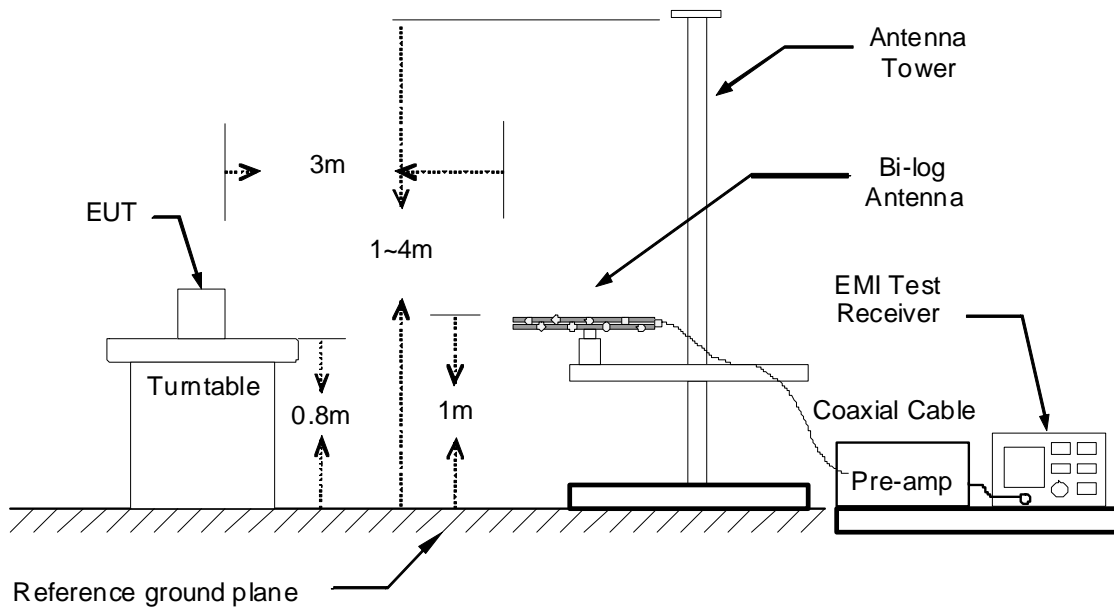

The diagram below shows the test setup that is utilized to make the measurements for emission above 1GHz.

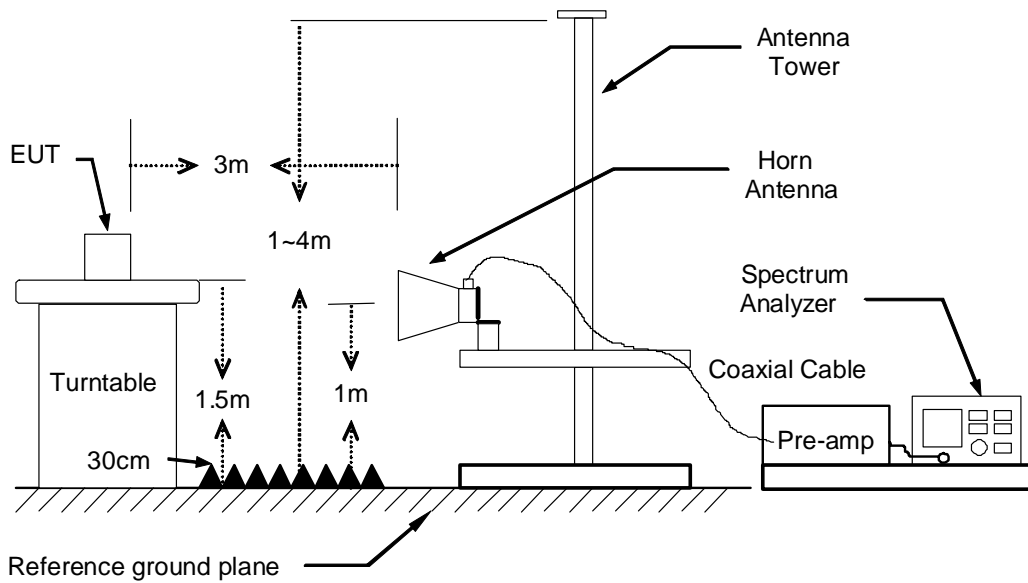

## **TEST PROCEDURE**

1. The EUT was placed on the top of a rotating table 0.8 and 1.5 meters above the ground. The table was rotated 360 degrees to determine the position of the highest radiation.
2. While measuring the radiated emission below 1GHz, the EUT was set 3 meters away from the interference-receiving antenna, which was mounted on the top of a variable-height antenna tower. While measuring the radiated emission above 1GHz, the EUT was set 3 meters away from the interference-receiving antenna.
3. The antenna is a broadband antenna, and its height is varied from one meter to four meters above the ground to determine the maximum value of the field strength. Both horizontal and vertical polarization of the antenna are set to make the measurement.
4. For each suspected emission, the EUT was arranged to its worst case and then the antenna was tuned to heights from 1 meter to 4 meters and the table was turned from 0 degrees to 360 degrees to find the maximum reading.
5. The test-receiver system was set to Peak Detect Function and Specified Bandwidth with Maximum Hold Mode.
6. If the emission level of the EUT in peak mode was 10 dB lower than the limit specified, then testing could be stopped and the peak values of the EUT would be reported. Otherwise the emissions that did not have 10 dB margin would be re-tested one by one using peak, quasi-peak or average method as specified and then reported in a data sheet.

### **Remark :**

1. *The resolution bandwidth and video bandwidth of test receiver/spectrum analyzer is 120 KHz for Peak detection (PK) and Quasi-peak detection (QP) at frequency below 1GHz.*
2. *The resolution bandwidth and video bandwidth of test receiver/spectrum analyzer is 1 MHz for Peak detection and frequency above 1GHz.*
3. *The resolution bandwidth of test receiver/spectrum analyzer is 1 MHz and the video bandwidth is 10 Hz for Average detection (AV) at frequency above 1GHz.*

**TEST RESULTS**

**Below 1 GHz (9kHz ~ 30MHz)**

No emission found between lowest internal used/generated frequency to 30MHz.

**Below 1 GHz (30MHz ~ 1GHz)**

|                     |           |                             |            |
|---------------------|-----------|-----------------------------|------------|
| <b>Product Name</b> | MX-LOCare | <b>Test By</b>              | Crystal Wu |
| <b>Test Model</b>   | BR1       | <b>Test Date</b>            | 2015/06/23 |
| <b>Test Mode</b>    | Mode 1    | <b>Temp. &amp; Humidity</b> | 25°C, 50%  |

966 Chamber\_C at 3Meter / Horizontal

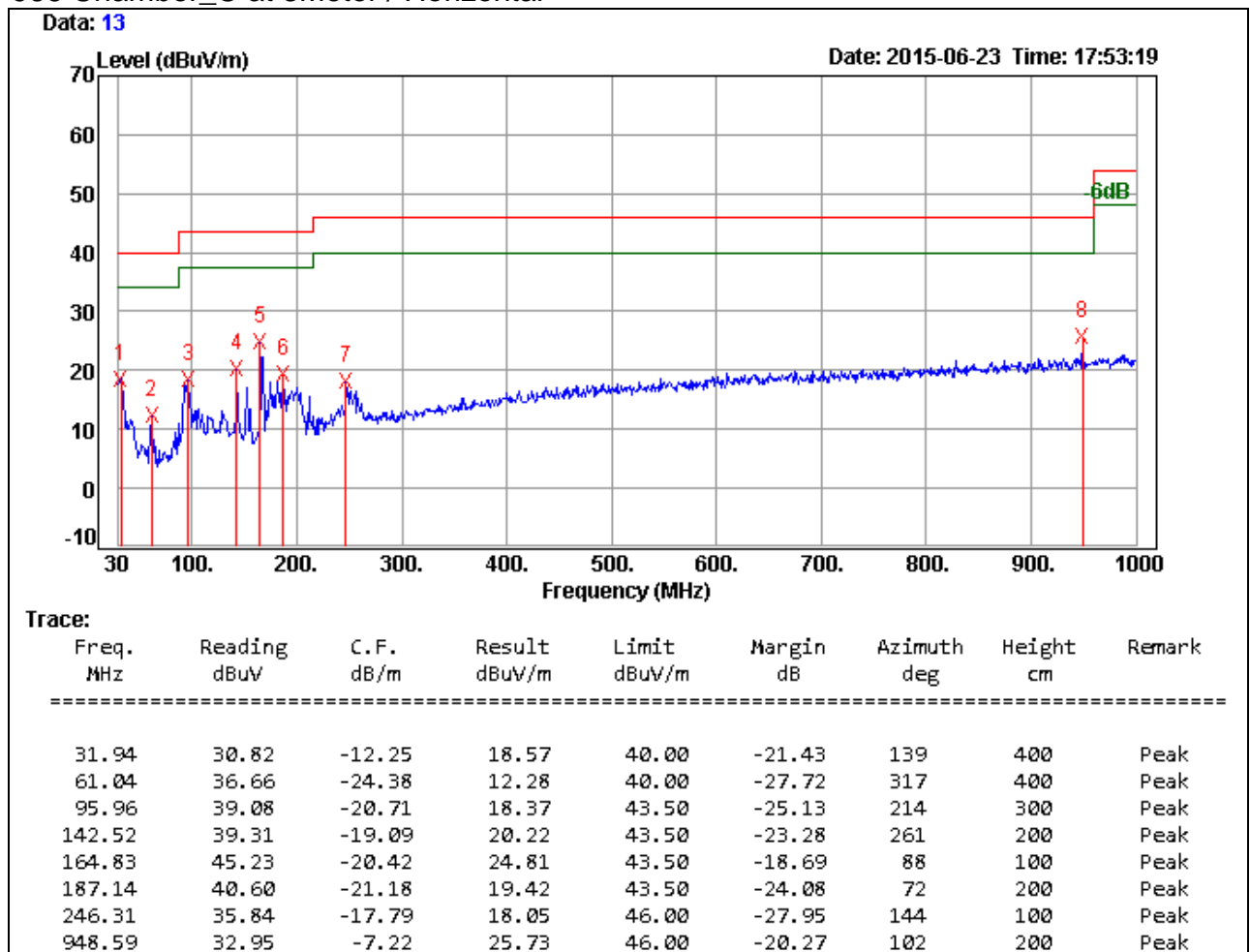

**Remark:**

1. Quasi-peak test would be performed if the peak result were greater than the quasi-peak limit.
2. Correction Factor (dB/m) = Antenna Factor (dB/m) + Cable Loss (dB) – PreAmp.Gain (dB)
3. Result (dBuV/m) = Reading (dBuV) + Correction Factor (dB/m)
4. Margin (dB) = Remark result (dBuV/m) - Quasi-peak limit (dBuV/m).

|                     |           |                             |            |
|---------------------|-----------|-----------------------------|------------|
| <b>Product Name</b> | MX-LOCare | <b>Test By</b>              | Crystal Wu |
| <b>Test Model</b>   | BR1       | <b>Test Date</b>            | 2015/06/23 |
| <b>Test Mode</b>    | Mode 1    | <b>Temp. &amp; Humidity</b> | 25°C, 50%  |

966 Chamber\_C at 3Meter / Vertical

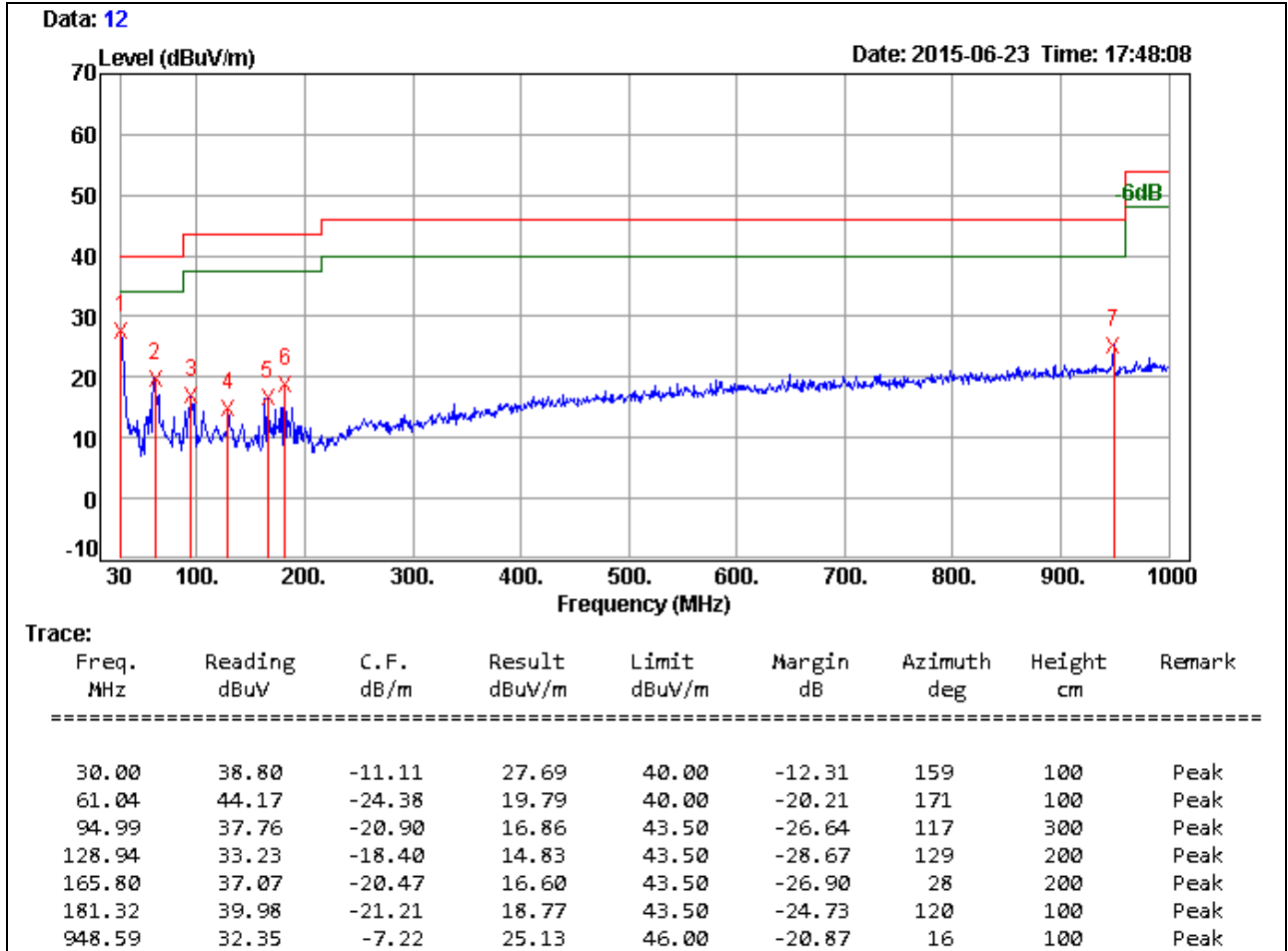

**Remark:**

1. Quasi-peak test would be performed if the peak result were greater than the quasi-peak limit.
2. Correction Factor (dB/m) = Antenna Factor (dB/m) + Cable Loss (dB) – PreAmp.Gain (dB)
3. Result (dBUV/m) = Reading (dBUV) + Correction Factor (dB/m)
4. Margin (dB) = Remark result (dBUV/m) - Quasi-peak limit (dBUV/m).

**Above 1 GHz**

|                     |                  |                             |            |
|---------------------|------------------|-----------------------------|------------|
| <b>Product Name</b> | MX-LOCare        | <b>Test By</b>              | Rex Chiu   |
| <b>Test Model</b>   | BR1              | <b>Test Date</b>            | 2015/06/15 |
| <b>Test Mode</b>    | GFSK TX / CH Low | <b>Temp. &amp; Humidity</b> | 25°C, 56%  |

| <b>966 Chamber_B at 3Meter / Horizontal</b> |                   |                   |                          |                                   |                    |                    |                   |                   |             |        |
|---|-------------------|-------------------|--------------------------|-----------------------------------|--------------------|--------------------|-------------------|-------------------|-------------|--------|
| Frequency (MHz)                             | Reading-PK (dBuV) | Reading-AV (dBuV) | Correction Factor (dB/m) | Duty Cycle Correction Factor (dB) | Result-PK (dBuV/m) | Result-AV (dBuV/m) | Limit-PK (dBuV/m) | Limit-AV (dBuV/m) | Margin (dB) | Remark |
| 1596.00                                     | 46.98             | ---               | -1.97                    |                                   | 45.01              | ---                | 74.00             | 54.00             | -8.99       | Peak   |
| 1970.00                                     | 42.96             | ---               | 1.50                     |                                   | 44.46              | ---                | 74.00             | 54.00             | -9.54       | Peak   |
| 2486.00                                     | 43.42             | ---               | 2.98                     |                                   | 46.39              | ---                | 74.00             | 54.00             | -7.61       | Peak   |
| 3600.00                                     | 51.73             | 39.80             | 5.22                     |                                   | 56.95              | 45.02              | 74.00             | 54.00             | -8.98       | AVG    |
| *4800.00                                    | 47.97             | ---               | 7.98                     | -20.00                            | 55.95              | ---                | 74.00             | 54.00             | -18.05      | Peak   |
| *7200.00                                    | 42.49             | ---               | 11.85                    | -20.00                            | 54.34              | 34.34              | 74.00             | 54.00             | -19.66      | AVG    |
| *12015.00                                   | 42.76             | ---               | 19.99                    | -20.00                            | 62.75              | 42.75              | 74.00             | 54.00             | -11.25      | AVG    |

| <b>966 Chamber_B at 3Meter / Vertical</b> |                   |                   |                          |                                   |                    |                    |                   |                   |             |        |
|---|-------------------|-------------------|--------------------------|-----------------------------------|--------------------|--------------------|-------------------|-------------------|-------------|--------|
| Frequency (MHz)                           | Reading-PK (dBuV) | Reading-AV (dBuV) | Correction Factor (dB/m) | Duty Cycle Correction Factor (dB) | Result-PK (dBuV/m) | Result-AV (dBuV/m) | Limit-PK (dBuV/m) | Limit-AV (dBuV/m) | Margin (dB) | Remark |
| 1600                                      | 46.78             | ---               | -1.93                    |                                   | 44.85              | ---                | 74.00             | 54.00             | -9.15       | Peak   |
| 2258                                      | 42.61             | ---               | 2.41                     |                                   | 45.02              | ---                | 74.00             | 54.00             | -8.98       | Peak   |
| 2660                                      | 42.7              | ---               | 3.34                     |                                   | 46.04              | ---                | 74.00             | 54.00             | -7.96       | Peak   |
| 3600                                      | 48.71             | 38.68             | 5.22                     |                                   | 53.93              | 43.90              | 74.00             | 54.00             | -10.10      | AVG    |
| *4800                                     | 45.86             | ---               | 7.98                     | -20.00                            | 53.84              | 33.84              | 74.00             | 54.00             | -20.16      | AVG    |
| *7200                                     | 45.83             | ---               | 11.85                    | -20.00                            | 57.68              | 37.68              | 74.00             | 54.00             | -16.32      | AVG    |
| *12015                                    | 40.11             | ---               | 19.99                    | -20.00                            | 60.10              | 40.10              | 74.00             | 54.00             | -13.90      | AVG    |

**Remark:**

1. Measuring frequencies from 1 GHz to the 10th harmonic of highest fundamental frequency.
2. Average test would be performed if the peak result were greater than the average limit.
3. Data of measurement within this frequency range shown " --- " in the table above means the reading of emissions are attenuated more than 20dB below the permissible limits or the field strength is too small to be measured.
4. Measurements above show only up to 6 maximum emissions noted, or would be lesser, with " N/A " remark, if no specific emissions from the EUT are recorded (ie: margin>20dB from the applicable limit) and considered that's already beyond the background noise floor.
5. Result = Reading + Correction Factor  
 Margin = Result - Limit  
 Remark Peak = Result(PK) - Limit(AV)  
 Remark AVG = Result(AV) - Limit(AV)
6. " \* " For Fundamental & Harmonics: Result-AV = Result(PK) + Duty Cycle Correction Factor

|                     |                     |                             |            |
|---------------------|---------------------|-----------------------------|------------|
| <b>Product Name</b> | MX-LOCare           | <b>Test By</b>              | Rex Chiu   |
| <b>Test Model</b>   | BR1                 | <b>Test Date</b>            | 2015/06/15 |
| <b>Test Mode</b>    | GFSK TX / CH Middle | <b>Temp. &amp; Humidity</b> | 25°C, 56%  |

| 966 Chamber_B at 3Meter / Horizontal |                   |                   |                          |                                   |                    |                    |                   |                   |             |        |
|--------------------------------------|-------------------|-------------------|--------------------------|-----------------------------------|--------------------|--------------------|-------------------|-------------------|-------------|--------|
| Frequency (MHz)                      | Reading-PK (dBuV) | Reading-AV (dBuV) | Correction Factor (dB/m) | Duty Cycle Correction Factor (dB) | Result-PK (dBuV/m) | Result-AV (dBuV/m) | Limit-PK (dBuV/m) | Limit-AV (dBuV/m) | Margin (dB) | Remark |
| 1602.00                              | 47.83             | ---               | -1.91                    |                                   | 45.92              | ---                | 74.00             | 54.00             | -8.08       | Peak   |
| 2300.00                              | 42.47             | ---               | 2.52                     |                                   | 44.99              | ---                | 74.00             | 54.00             | -9.01       | Peak   |
| 2650.00                              | 42.74             | ---               | 3.32                     |                                   | 46.06              | ---                | 74.00             | 54.00             | -7.94       | Peak   |
| 3660.00                              | 52.84             | 40.35             | 5.33                     |                                   | 58.17              | 45.68              | 74.00             | 54.00             | -8.32       | AVG    |
| *4875.00                             | 47.96             | ---               | 8.04                     | -20.00                            | 56.00              | 36.00              | 74.00             | 54.00             | -18.00      | AVG    |
| *7320.00                             | 42.59             | ---               | 11.57                    | -20.00                            | 54.16              | 34.16              | 74.00             | 54.00             | -19.84      | AVG    |
| *9765.00                             | 40.50             | ---               | 14.31                    | -20.00                            | 54.81              | 34.81              | 74.00             | 54.00             | -19.19      | AVG    |
| *12210.00                            | 42.15             | ---               | 20.13                    | -20.00                            | 62.28              | 42.28              | 74.00             | 54.00             | -11.72      | AVG    |

| 966 Chamber_B at 3Meter / Vertical |                   |                   |                          |                                   |                    |                    |                   |                   |             |        |
|------------------------------------|-------------------|-------------------|--------------------------|-----------------------------------|--------------------|--------------------|-------------------|-------------------|-------------|--------|
| Frequency (MHz)                    | Reading-PK (dBuV) | Reading-AV (dBuV) | Correction Factor (dB/m) | Duty Cycle Correction Factor (dB) | Result-PK (dBuV/m) | Result-AV (dBuV/m) | Limit-PK (dBuV/m) | Limit-AV (dBuV/m) | Margin (dB) | Remark |
| 1600.00                            | 45.81             | ---               | -1.93                    |                                   | 43.88              | ---                | 74.00             | 54.00             | -10.12      | Peak   |
| 2036.00                            | 43.34             | ---               | 1.87                     |                                   | 45.21              | ---                | 74.00             | 54.00             | -8.79       | Peak   |
| 2670.00                            | 43.09             | ---               | 3.36                     |                                   | 46.45              | ---                | 74.00             | 54.00             | -7.55       | Peak   |
| 3660.00                            | 49.94             | 39.15             | 5.33                     |                                   | 55.27              | 44.48              | 74.00             | 54.00             | -9.52       | AVG    |
| *4875.00                           | 46.24             | ---               | 8.04                     | -20.00                            | 54.28              | 34.28              | 74.00             | 54.00             | -19.72      | AVG    |
| *12210.00                          | 41.75             | ---               | 20.13                    | -20.00                            | 61.88              | 41.88              | 74.00             | 54.00             | -12.12      | AVG    |
| 14640.00                           | 42.40             | 30.77             | 22.71                    |                                   | 65.11              | 53.48              | 74.00             | 54.00             | -0.52       | AVG    |

**Remark:**

1. Measuring frequencies from 1 GHz to the 10th harmonic of highest fundamental frequency.
2. Average test would be performed if the peak result were greater than the average limit.
3. Data of measurement within this frequency range shown " --- " in the table above means the reading of emissions are attenuated more than 20dB below the permissible limits or the field strength is too small to be measured.
4. Measurements above show only up to 6 maximum emissions noted, or would be lesser, with " N/A " remark, if no specific emissions from the EUT are recorded (ie: margin>20dB from the applicable limit) and considered that's already beyond the background noise floor.
5. Result = Reading + Correction Factor  
 Margin = Result - Limit  
 Remark Peak = Result(PK) - Limit(AV)  
 Remark AVG = Result(AV) - Limit(AV)
6. " \* " For Fundamental & Harmonics: Result-AV = Result(PK) + Duty Cycle Correction Factor

|                     |                   |                             |            |
|---------------------|-------------------|-----------------------------|------------|
| <b>Product Name</b> | MX-LOCare         | <b>Test By</b>              | Rex Chiu   |
| <b>Test Model</b>   | BR1               | <b>Test Date</b>            | 2015/06/15 |
| <b>Test Mode</b>    | GFSK TX / CH High | <b>Temp. &amp; Humidity</b> | 25°C, 56%  |

| 966 Chamber_B at 3Meter / Horizontal |                   |                   |                          |                                   |                    |                    |                   |                   |             |        |
|--------------------------------------|-------------------|-------------------|--------------------------|-----------------------------------|--------------------|--------------------|-------------------|-------------------|-------------|--------|
| Frequency (MHz)                      | Reading-PK (dBuV) | Reading-AV (dBuV) | Correction Factor (dB/m) | Duty Cycle Correction Factor (dB) | Result-PK (dBuV/m) | Result-AV (dBuV/m) | Limit-PK (dBuV/m) | Limit-AV (dBuV/m) | Margin (dB) | Remark |
| 1596.00                              | 47.56             | ---               | -1.97                    |                                   | 45.60              | ---                | 74.00             | 54.00             | -8.40       | Peak   |
| 2022.00                              | 43.46             | ---               | 1.83                     |                                   | 45.30              | ---                | 74.00             | 54.00             | -8.70       | Peak   |
| 2560.00                              | 43.43             | ---               | 3.13                     |                                   | 46.56              | ---                | 74.00             | 54.00             | -7.44       | Peak   |
| 3720.00                              | 43.32             | ---               | 5.44                     |                                   | 48.76              | ---                | 74.00             | 54.00             | -5.24       | Peak   |
| 4965.00                              | 43.29             | ---               | 8.11                     |                                   | 51.40              | ---                | 74.00             | 54.00             | -22.60      | Peak   |
| 14850.00                             | 38.40             | 27.88             | 23.67                    |                                   | 62.07              | 51.55              | 74.00             | 54.00             | -2.45       | AVG    |

| 966 Chamber_B at 3Meter / Vertical |                   |                   |                          |                                   |                    |                    |                   |                   |             |        |
|------------------------------------|-------------------|-------------------|--------------------------|-----------------------------------|--------------------|--------------------|-------------------|-------------------|-------------|--------|
| Frequency (MHz)                    | Reading-PK (dBuV) | Reading-AV (dBuV) | Correction Factor (dB/m) | Duty Cycle Correction Factor (dB) | Result-PK (dBuV/m) | Result-AV (dBuV/m) | Limit-PK (dBuV/m) | Limit-AV (dBuV/m) | Margin (dB) | Remark |
| 1604.00                            | 45.65             | ---               | -1.89                    |                                   | 43.76              | ---                | 74.00             | 54.00             | -10.24      | Peak   |
| 2000.00                            | 43.99             | ---               | 1.78                     |                                   | 45.77              | ---                | 74.00             | 54.00             | -8.23       | Peak   |
| 2746.00                            | 42.85             | ---               | 3.51                     |                                   | 46.37              | ---                | 74.00             | 54.00             | -7.63       | Peak   |
| 3720.00                            | 42.14             | ---               | 5.44                     |                                   | 47.59              | ---                | 74.00             | 54.00             | -6.41       | Peak   |
| 4905.00                            | 40.55             | ---               | 8.06                     |                                   | 48.61              | ---                | 74.00             | 54.00             | -5.39       | Peak   |
| 14880.00                           | 37.22             | 28.80             | 23.81                    |                                   | 61.03              | 52.61              | 74.00             | 54.00             | -1.39       | AVG    |

**Remark:**

1. Measuring frequencies from 1 GHz to the 10th harmonic of highest fundamental frequency.
2. Average test would be performed if the peak result were greater than the average limit.
3. Data of measurement within this frequency range shown " --- " in the table above means the reading of emissions are attenuated more than 20dB below the permissible limits or the field strength is too small to be measured.
4. Measurements above show only up to 6 maximum emissions noted, or would be lesser, with " N/A " remark, if no specific emissions from the EUT are recorded (ie: margin>20dB from the applicable limit) and considered that's already beyond the background noise floor.
5. Result = Reading + Correction Factor  
 Margin = Result - Limit  
 Remark Peak = Result(PK) - Limit(AV)  
 Remark AVG = Result(AV) - Limit(AV)
6. " \* " For Fundamental & Harmonics: Result-AV = Result(PK) + Duty Cycle Correction Factor



|                     |                    |                             |            |
|---------------------|--------------------|-----------------------------|------------|
| <b>Product Name</b> | MX-LOCare          | <b>Test By</b>              | Rex Chiu   |
| <b>Test Model</b>   | BR1                | <b>Test Date</b>            | 2015/06/15 |
| <b>Test Mode</b>    | 8-DPSK TX / CH Low | <b>Temp. &amp; Humidity</b> | 25°C, 56%  |

| 966 Chamber_B at 3Meter / Horizontal |                   |                   |                          |                                   |                    |                    |                   |                   |             |        |
|--------------------------------------|-------------------|-------------------|--------------------------|-----------------------------------|--------------------|--------------------|-------------------|-------------------|-------------|--------|
| Frequency (MHz)                      | Reading-PK (dBuV) | Reading-AV (dBuV) | Correction Factor (dB/m) | Duty Cycle Correction Factor (dB) | Result-PK (dBuV/m) | Result-AV (dBuV/m) | Limit-PK (dBuV/m) | Limit-AV (dBuV/m) | Margin (dB) | Remark |
| 1600.00                              | 49.15             | ---               | -1.93                    |                                   | 47.22              | ---                | 74.00             | 54.00             | -6.78       | Peak   |
| 2194.00                              | 43.00             | ---               | 2.26                     |                                   | 45.26              | ---                | 74.00             | 54.00             | -8.74       | Peak   |
| 2486.00                              | 42.88             | ---               | 2.98                     |                                   | 45.86              | ---                | 74.00             | 54.00             | -8.14       | Peak   |
| 3600.00                              | 45.73             | ---               | 5.22                     |                                   | 50.94              | ---                | 74.00             | 54.00             | -3.06       | Peak   |
| *4800.00                             | 41.45             | ---               | 7.98                     | -20.00                            | 49.43              | 29.43              | 74.00             | 54.00             | -24.57      | AVG    |
| *12015.00                            | 41.14             | ---               | 19.99                    | -20.00                            | 61.13              | 41.13              | 74.00             | 54.00             | -12.87      | AVG    |

| 966 Chamber_B at 3Meter / Vertical |                   |                   |                          |                                   |                    |                    |                   |                   |             |        |
|------------------------------------|-------------------|-------------------|--------------------------|-----------------------------------|--------------------|--------------------|-------------------|-------------------|-------------|--------|
| Frequency (MHz)                    | Reading-PK (dBuV) | Reading-AV (dBuV) | Correction Factor (dB/m) | Duty Cycle Correction Factor (dB) | Result-PK (dBuV/m) | Result-AV (dBuV/m) | Limit-PK (dBuV/m) | Limit-AV (dBuV/m) | Margin (dB) | Remark |
| 1596.00                            | 46.13             | ---               | -1.97                    |                                   | 44.17              | ---                | 74.00             | 54.00             | -9.83       | Peak   |
| 1984.00                            | 44.09             | ---               | 1.63                     |                                   | 45.72              | ---                | 74.00             | 54.00             | -8.28       | Peak   |
| 2520.00                            | 42.85             | ---               | 3.05                     |                                   | 45.90              | ---                | 74.00             | 54.00             | -8.10       | Peak   |
| 3600.00                            | 44.37             | ---               | 5.22                     |                                   | 49.59              | ---                | 74.00             | 54.00             | -4.41       | Peak   |
| *4800.00                           | 43.84             | ---               | 7.98                     | -20.00                            | 51.82              | 31.82              | 74.00             | 54.00             | -22.18      | AVG    |
| *12015.00                          | 40.21             | ---               | 19.99                    | -20.00                            | 60.20              | 40.20              | 74.00             | 54.00             | -13.80      | AVG    |

**Remark:**

1. Measuring frequencies from 1 GHz to the 10th harmonic of highest fundamental frequency.
2. Average test would be performed if the peak result were greater than the average limit.
3. Data of measurement within this frequency range shown " --- " in the table above means the reading of emissions are attenuated more than 20dB below the permissible limits or the field strength is too small to be measured.
4. Measurements above show only up to 6 maximum emissions noted, or would be lesser, with " N/A " remark, if no specific emissions from the EUT are recorded (ie: margin>20dB from the applicable limit) and considered that's already beyond the background noise floor.
5. Result = Reading + Correction Factor  
 Margin = Result - Limit  
 Remark Peak = Result(PK) - Limit(AV)  
 Remark AVG = Result(AV) - Limit(AV)
6. " \* " For Fundamental & Harmonics: Result-AV = Result(PK) + Duty Cycle Correction Factor

|                     |                       |                             |            |
|---------------------|-----------------------|-----------------------------|------------|
| <b>Product Name</b> | MX-LOCare             | <b>Test By</b>              | Rex Chiu   |
| <b>Test Model</b>   | BR1                   | <b>Test Date</b>            | 2015/06/15 |
| <b>Test Mode</b>    | 8-DPSK TX / CH Middle | <b>Temp. &amp; Humidity</b> | 25°C, 56%  |

| 966 Chamber_B at 3Meter / Horizontal |                   |                   |                          |                                   |                    |                    |                   |                   |             |        |
|--------------------------------------|-------------------|-------------------|--------------------------|-----------------------------------|--------------------|--------------------|-------------------|-------------------|-------------|--------|
| Frequency (MHz)                      | Reading-PK (dBuV) | Reading-AV (dBuV) | Correction Factor (dB/m) | Duty Cycle Correction Factor (dB) | Result-PK (dBuV/m) | Result-AV (dBuV/m) | Limit-PK (dBuV/m) | Limit-AV (dBuV/m) | Margin (dB) | Remark |
| 1596.00                              | 47.52             | ---               | -1.97                    |                                   | 45.55              | ---                | 74.00             | 54.00             | -8.45       | Peak   |
| 2142.00                              | 43.26             | ---               | 2.13                     |                                   | 45.39              | ---                | 74.00             | 54.00             | -8.61       | Peak   |
| 2752.00                              | 42.16             | ---               | 3.52                     |                                   | 45.68              | ---                | 74.00             | 54.00             | -8.32       | Peak   |
| 3660.00                              | 46.09             | ---               | 5.33                     |                                   | 51.43              | ---                | 74.00             | 54.00             | -2.57       | Peak   |
| *4875.00                             | 44.65             | ---               | 8.04                     | -20.00                            | 52.69              | 32.69              | 74.00             | 54.00             | -21.31      | AVG    |
| *7320.00                             | 41.78             | ---               | 11.57                    | -20.00                            | 53.35              | 33.35              | 74.00             | 54.00             | -20.65      | AVG    |
| *12210.00                            | 41.09             | ---               | 20.13                    | -20.00                            | 61.22              | 41.22              | 74.00             | 54.00             | -12.78      | AVG    |

| 966 Chamber_B at 3Meter / Vertical |                   |                   |                          |                                   |                    |                    |                   |                   |             |        |
|------------------------------------|-------------------|-------------------|--------------------------|-----------------------------------|--------------------|--------------------|-------------------|-------------------|-------------|--------|
| Frequency (MHz)                    | Reading-PK (dBuV) | Reading-AV (dBuV) | Correction Factor (dB/m) | Duty Cycle Correction Factor (dB) | Result-PK (dBuV/m) | Result-AV (dBuV/m) | Limit-PK (dBuV/m) | Limit-AV (dBuV/m) | Margin (dB) | Remark |
| 1604.00                            | 46.54             | ---               | -1.89                    |                                   | 44.65              | ---                | 74.00             | 54.00             | -9.35       | Peak   |
| 2084.00                            | 43.80             | ---               | 1.99                     |                                   | 45.79              | ---                | 74.00             | 54.00             | -8.21       | Peak   |
| 2672.00                            | 42.98             | ---               | 3.36                     |                                   | 46.34              | ---                | 74.00             | 54.00             | -7.66       | Peak   |
| 4875.00                            | 41.50             | ---               | 8.04                     |                                   | 49.54              | ---                | 74.00             | 54.00             | -4.46       | Peak   |
| 6900.00                            | 39.65             | ---               | 12.18                    |                                   | 51.83              | ---                | 74.00             | 54.00             | -2.17       | Peak   |
| *12210.00                          | 41.45             | ---               | 20.13                    | -20.00                            | 61.58              | 41.58              | 74.00             | 54.00             | -12.42      | AVG    |

**Remark:**

1. Measuring frequencies from 1 GHz to the 10th harmonic of highest fundamental frequency.
2. Average test would be performed if the peak result were greater than the average limit.
3. Data of measurement within this frequency range shown " --- " in the table above means the reading of emissions are attenuated more than 20dB below the permissible limits or the field strength is too small to be measured.
4. Measurements above show only up to 6 maximum emissions noted, or would be lesser, with " N/A " remark, if no specific emissions from the EUT are recorded (ie: margin>20dB from the applicable limit) and considered that's already beyond the background noise floor.
5. Result = Reading + Correction Factor  
 Margin = Result - Limit  
 Remark Peak = Result(PK) - Limit(AV)  
 Remark AVG = Result(AV) - Limit(AV)
6. " \* " For Fundamental & Harmonics: Result-AV = Result(PK) + Duty Cycle Correction Factor

|                     |                     |                             |            |
|---------------------|---------------------|-----------------------------|------------|
| <b>Product Name</b> | MX-LOCare           | <b>Test By</b>              | Rex Chiu   |
| <b>Test Model</b>   | BR1                 | <b>Test Date</b>            | 2015/06/15 |
| <b>Test Mode</b>    | 8-DPSK TX / CH High | <b>Temp. &amp; Humidity</b> | 25°C, 56%  |

| <b>966 Chamber_B at 3Meter / Horizontal</b> |                   |                   |                          |                                   |                    |                    |                   |                   |             |        |
|---|-------------------|-------------------|--------------------------|-----------------------------------|--------------------|--------------------|-------------------|-------------------|-------------|--------|
| Frequency (MHz)                             | Reading-PK (dBuV) | Reading-AV (dBuV) | Correction Factor (dB/m) | Duty Cycle Correction Factor (dB) | Result-PK (dBuV/m) | Result-AV (dBuV/m) | Limit-PK (dBuV/m) | Limit-AV (dBuV/m) | Margin (dB) | Remark |
| 1604.00                                     | 48.54             | ---               | -1.89                    |                                   | 46.64              | ---                | 74.00             | 54.00             | -7.36       | Peak   |
| 2162.00                                     | 42.69             | ---               | 2.18                     |                                   | 44.87              | ---                | 74.00             | 54.00             | -9.13       | Peak   |
| 2502.00                                     | 43.69             | ---               | 3.01                     |                                   | 46.71              | ---                | 74.00             | 54.00             | -7.29       | Peak   |
| 3120.00                                     | 42.27             | ---               | 4.27                     |                                   | 46.54              | ---                | 74.00             | 54.00             | -7.46       | Peak   |
| 4725.00                                     | 40.38             | ---               | 7.92                     |                                   | 48.30              | ---                | 74.00             | 54.00             | -5.70       | Peak   |
| 6960.00                                     | 38.72             | ---               | 12.26                    |                                   | 50.97              | ---                | 74.00             | 54.00             | -3.03       | Peak   |

| <b>966 Chamber_B at 3Meter / Vertical</b> |                   |                   |                          |                                   |                    |                    |                   |                   |             |        |
|---|-------------------|-------------------|--------------------------|-----------------------------------|--------------------|--------------------|-------------------|-------------------|-------------|--------|
| Frequency (MHz)                           | Reading-PK (dBuV) | Reading-AV (dBuV) | Correction Factor (dB/m) | Duty Cycle Correction Factor (dB) | Result-PK (dBuV/m) | Result-AV (dBuV/m) | Limit-PK (dBuV/m) | Limit-AV (dBuV/m) | Margin (dB) | Remark |
| 1982.00                                   | 44.38             | ---               | 1.61                     |                                   | 45.99              | ---                | 74.00             | 54.00             | -8.01       | Peak   |
| 2294.00                                   | 42.68             | ---               | 2.50                     |                                   | 45.18              | ---                | 74.00             | 54.00             | -8.82       | Peak   |
| 2686.00                                   | 42.60             | ---               | 3.39                     |                                   | 45.99              | ---                | 74.00             | 54.00             | -8.01       | Peak   |
| 3165.00                                   | 42.31             | ---               | 4.36                     |                                   | 46.67              | ---                | 74.00             | 54.00             | -7.33       | Peak   |
| 4500.00                                   | 41.47             | ---               | 7.74                     |                                   | 49.21              | ---                | 74.00             | 54.00             | -4.79       | Peak   |
| 6900.00                                   | 39.45             | ---               | 12.18                    |                                   | 51.63              | ---                | 74.00             | 54.00             | -2.37       | Peak   |

**Remark:**

1. Measuring frequencies from 1 GHz to the 10th harmonic of highest fundamental frequency.
2. Average test would be performed if the peak result were greater than the average limit.
3. Data of measurement within this frequency range shown " --- " in the table above means the reading of emissions are attenuated more than 20dB below the permissible limits or the field strength is too small to be measured.
4. Measurements above show only up to 6 maximum emissions noted, or would be lesser, with " N/A " remark, if no specific emissions from the EUT are recorded (ie: margin>20dB from the applicable limit) and considered that's already beyond the background noise floor.
5. Result = Reading + Correction Factor  
 Margin = Result - Limit  
 Remark Peak = Result(PK) - Limit(AV)  
 Remark AVG = Result(AV) - Limit(AV)
6. " \* " For Fundamental & Harmonics: Result-AV = Result(PK) + Duty Cycle Correction Factor

**Restricted Band Edges**

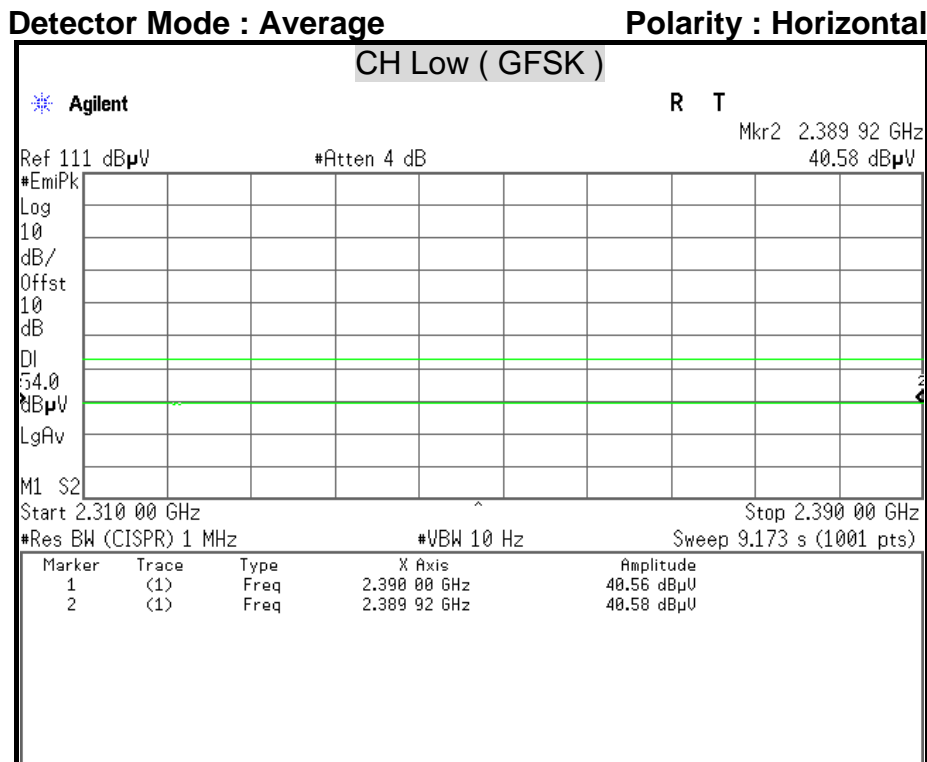
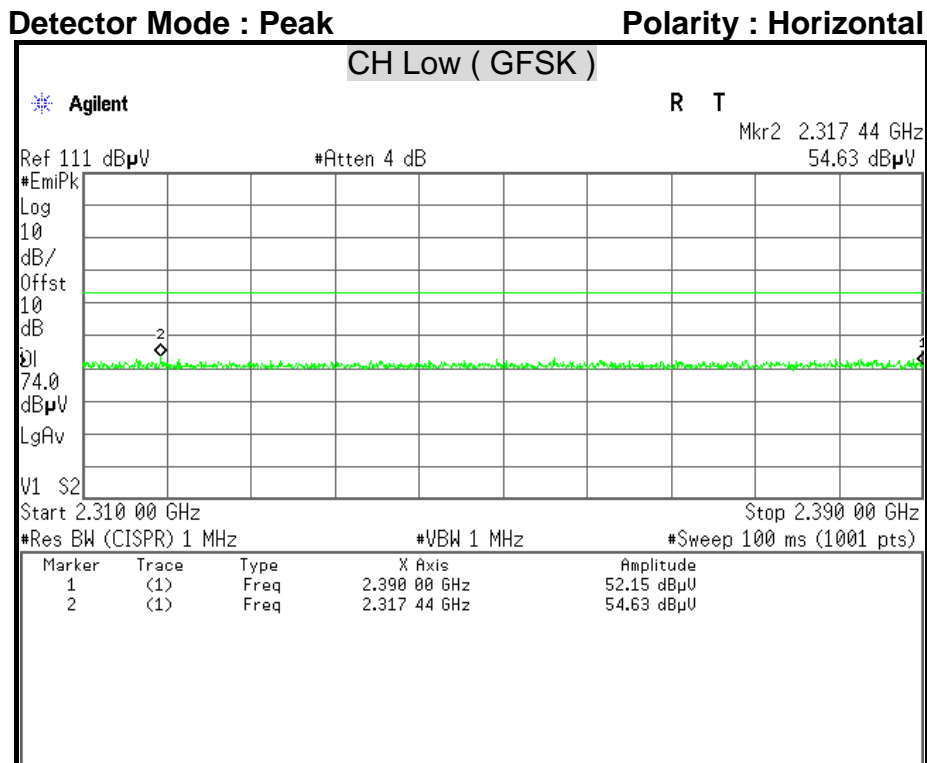

**Detector Mode : Peak**

**Polarity : Vertical**

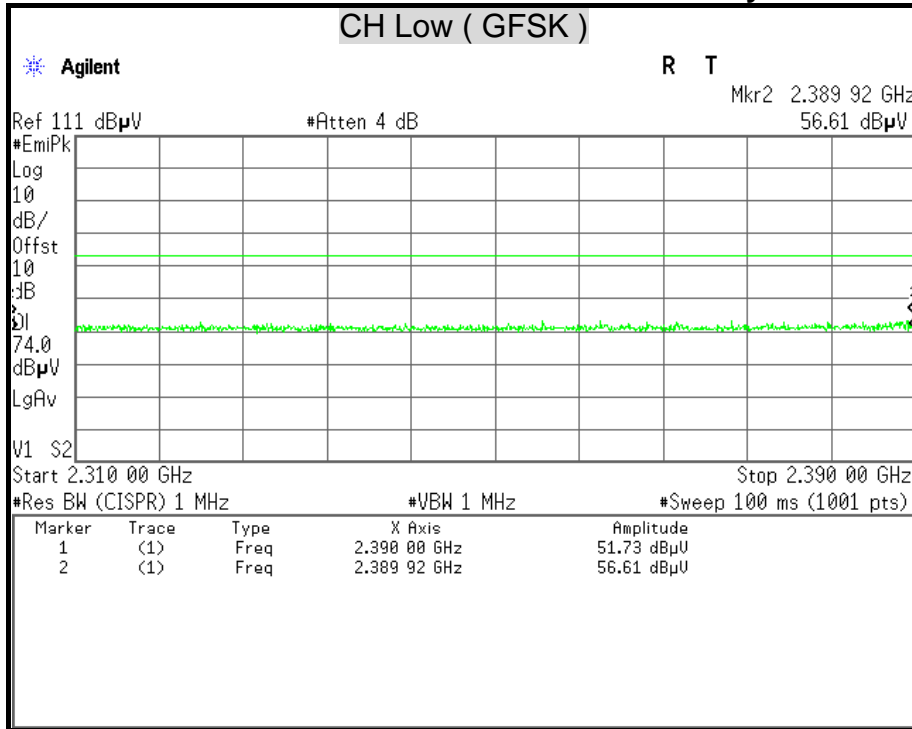

**Detector Mode : Average**

**Polarity : Vertical**

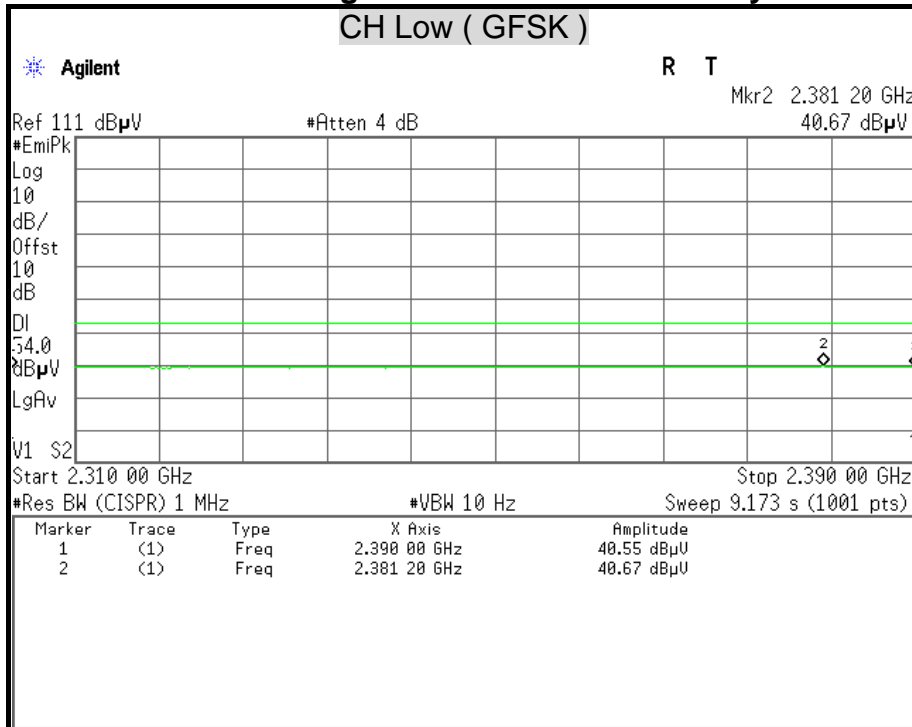

**Detector Mode : Peak** **Polarity : Horizontal**

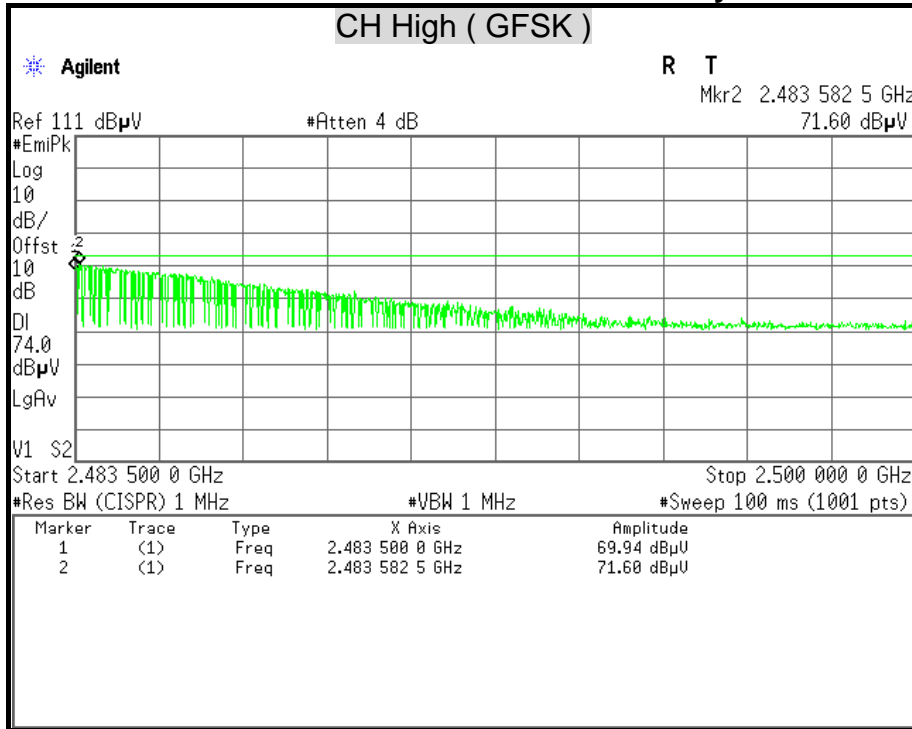

**Detector Mode : Average** **Polarity : Horizontal**

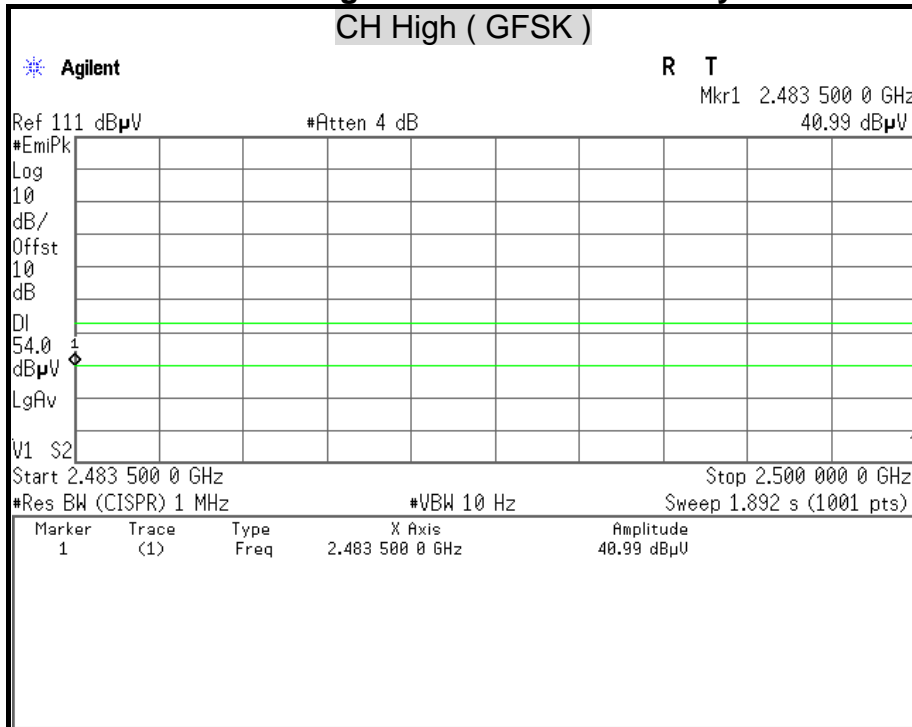

**Detector Mode : Peak** **Polarity : Vertical**

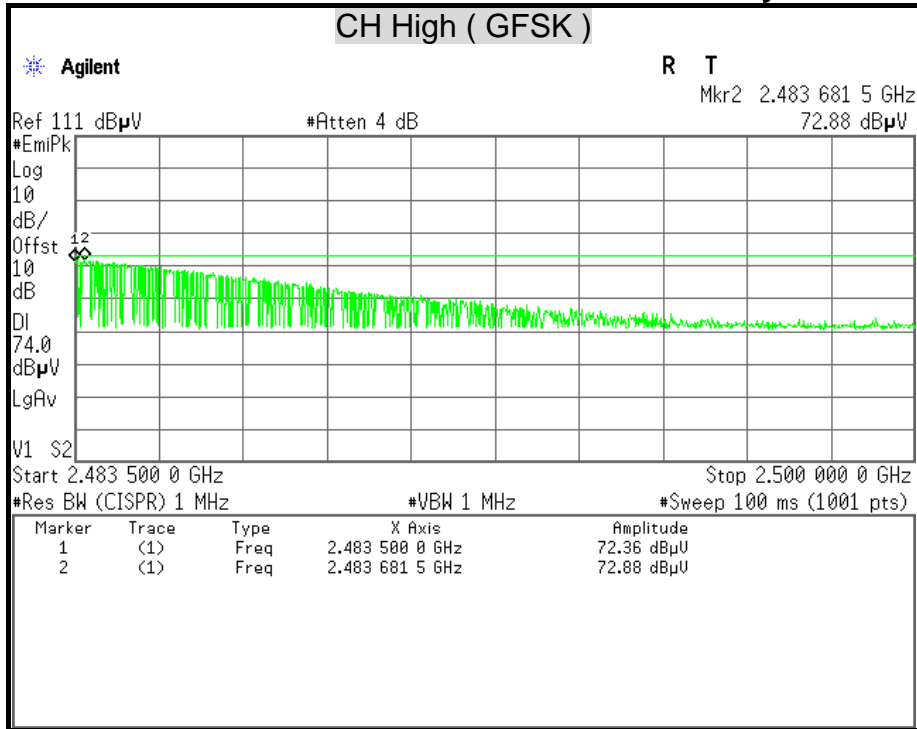

**Detector Mode : Average** **Polarity : Vertical**

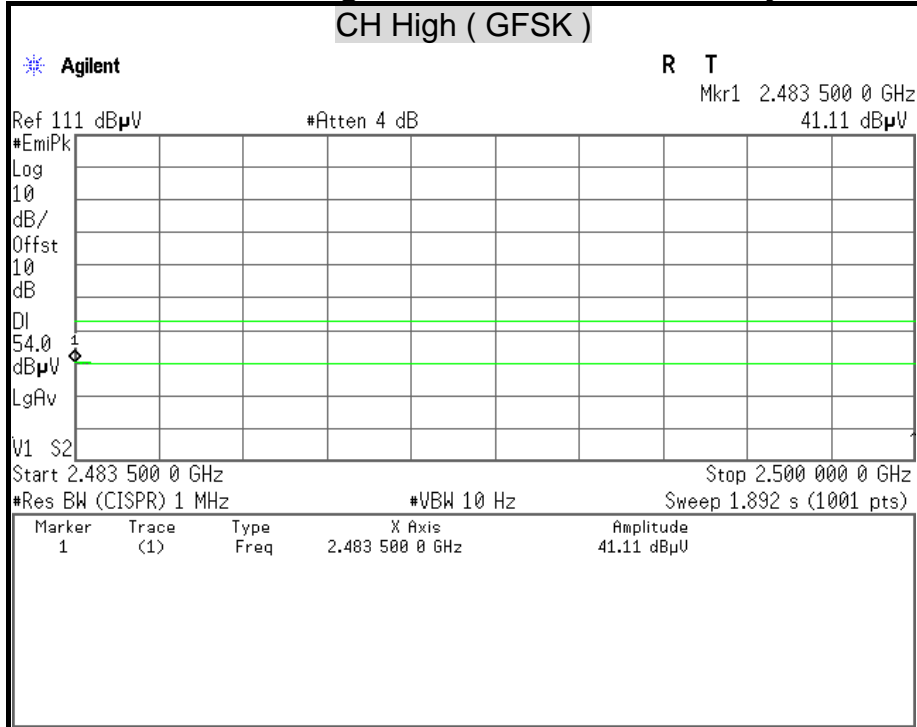

**Detector Mode : Peak Polarity : Horizontal**

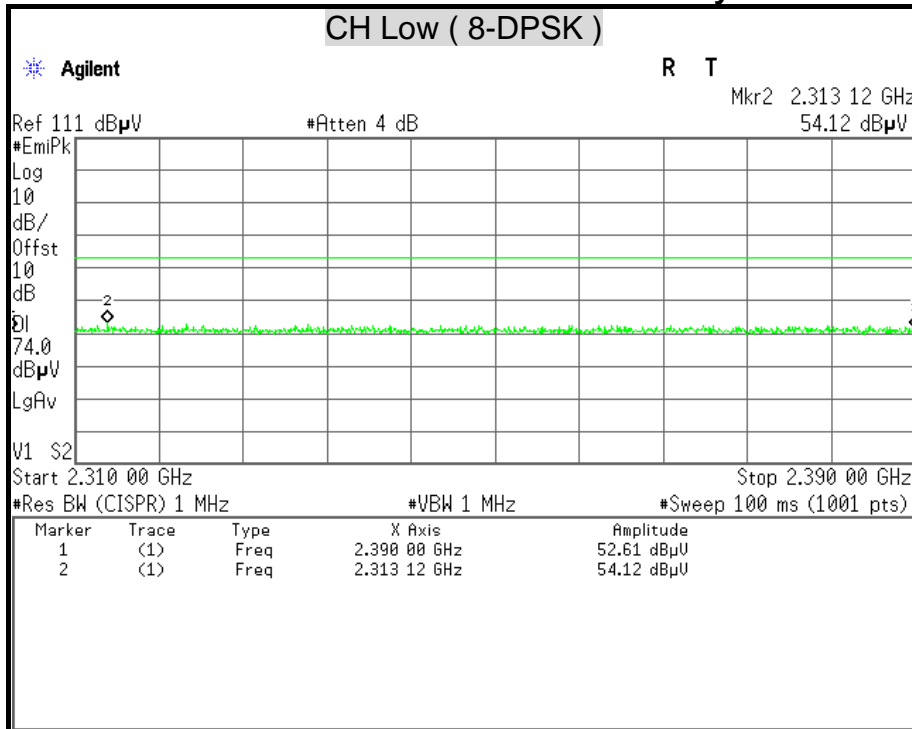

**Detector Mode : Average Polarity : Horizontal**

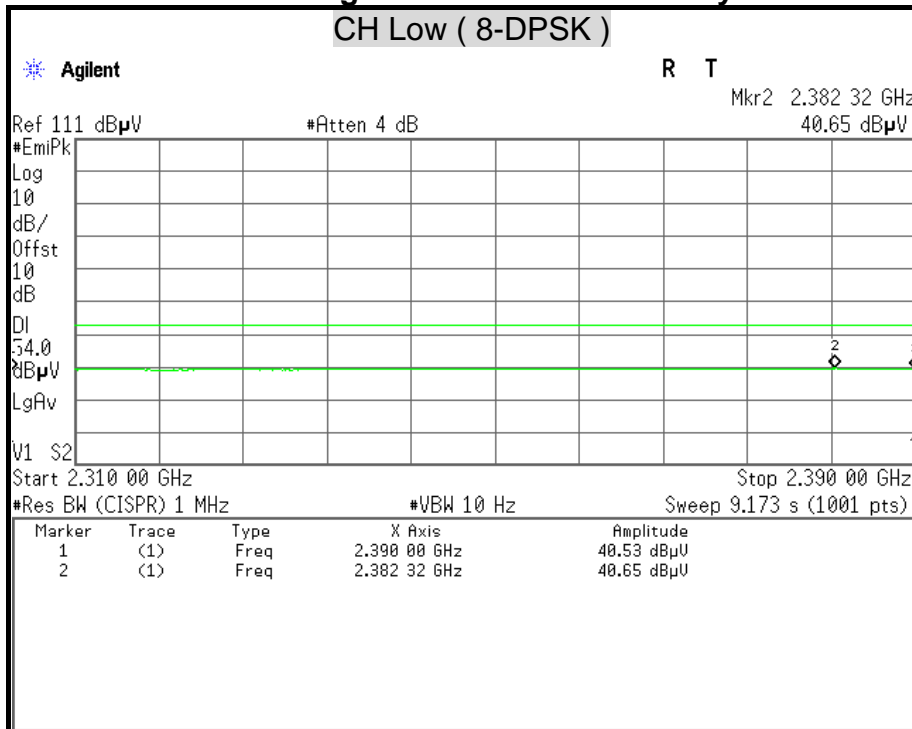



**Detector Mode : Peak**

**Polarity : Vertical**

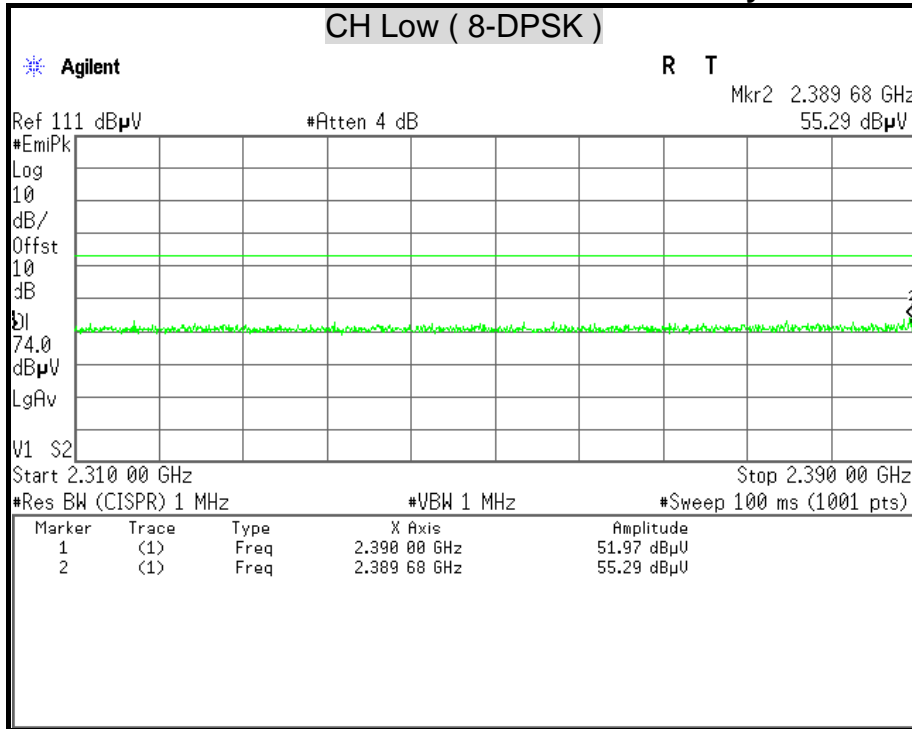

**Detector Mode : Average**

**Polarity : Vertical**

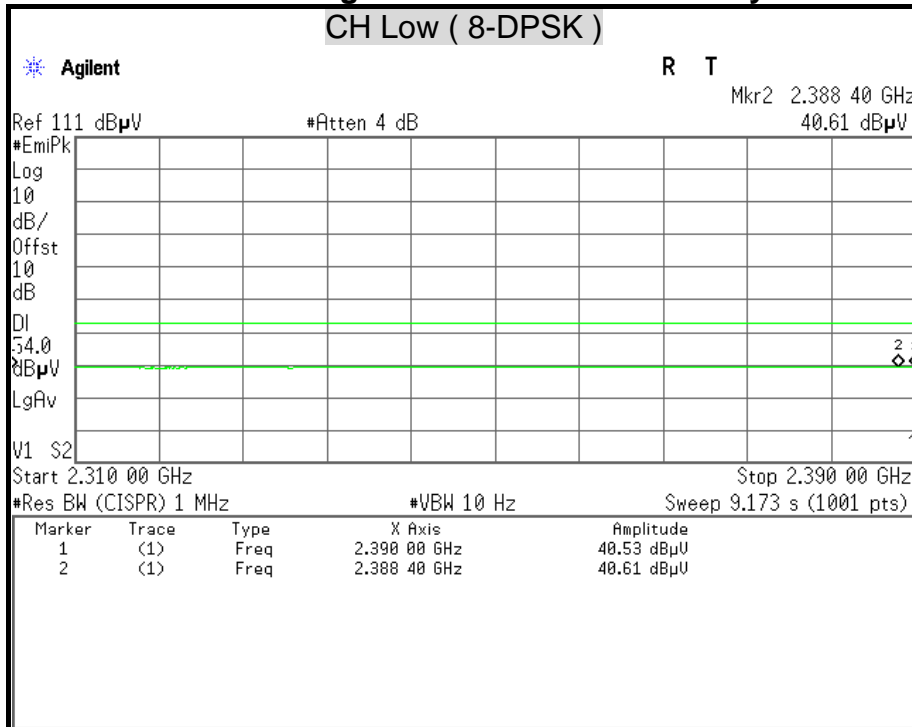

**Detector Mode : Peak** **Polarity : Horizontal**

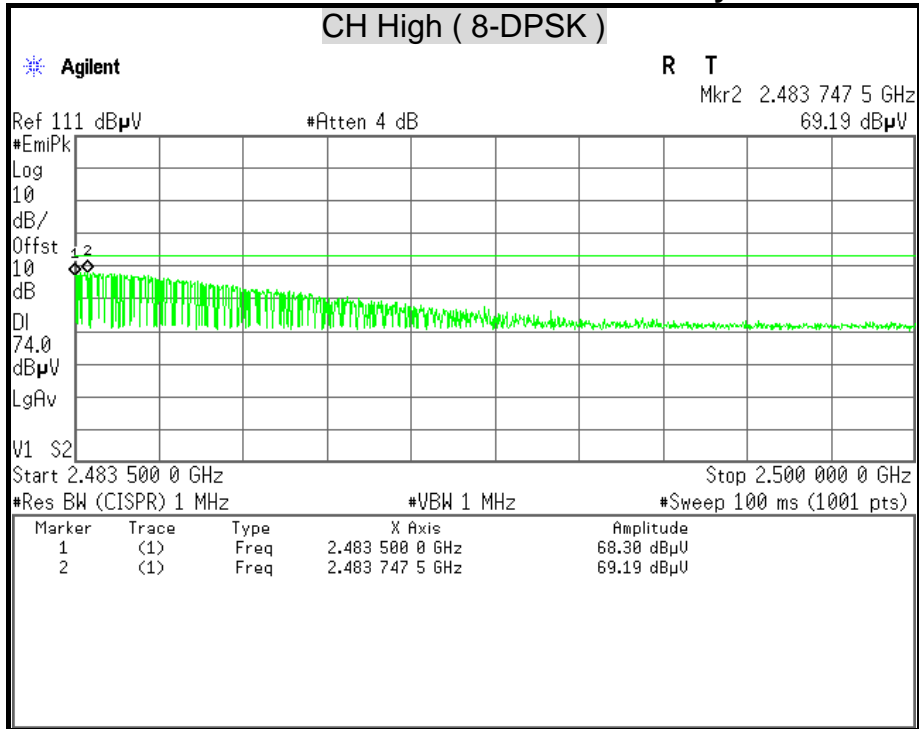

**Detector Mode : Average** **Polarity : Horizontal**

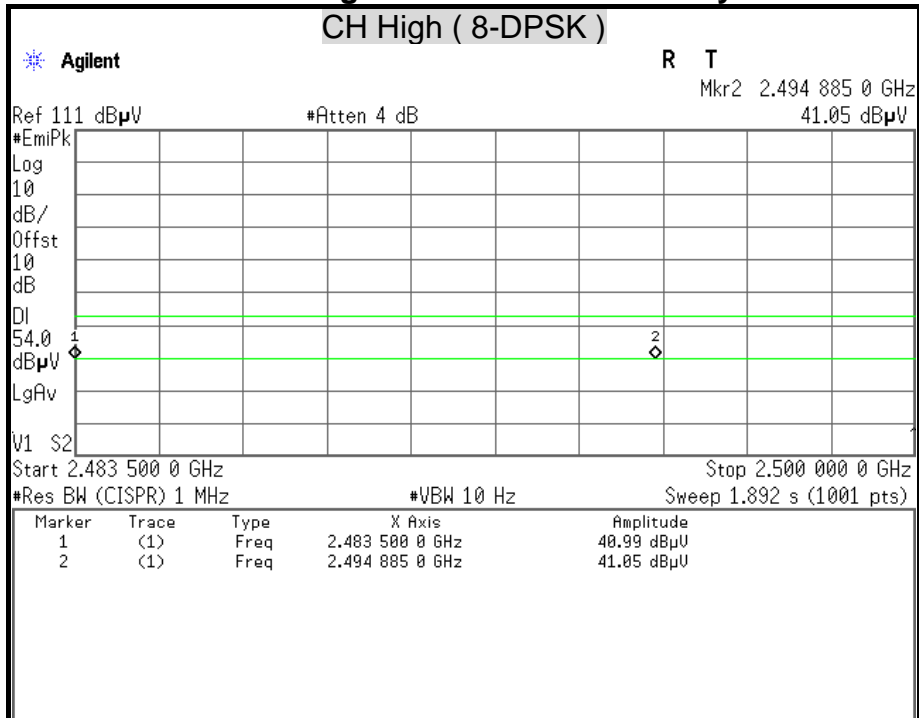

**Detector Mode : Peak** **Polarity : Vertical**

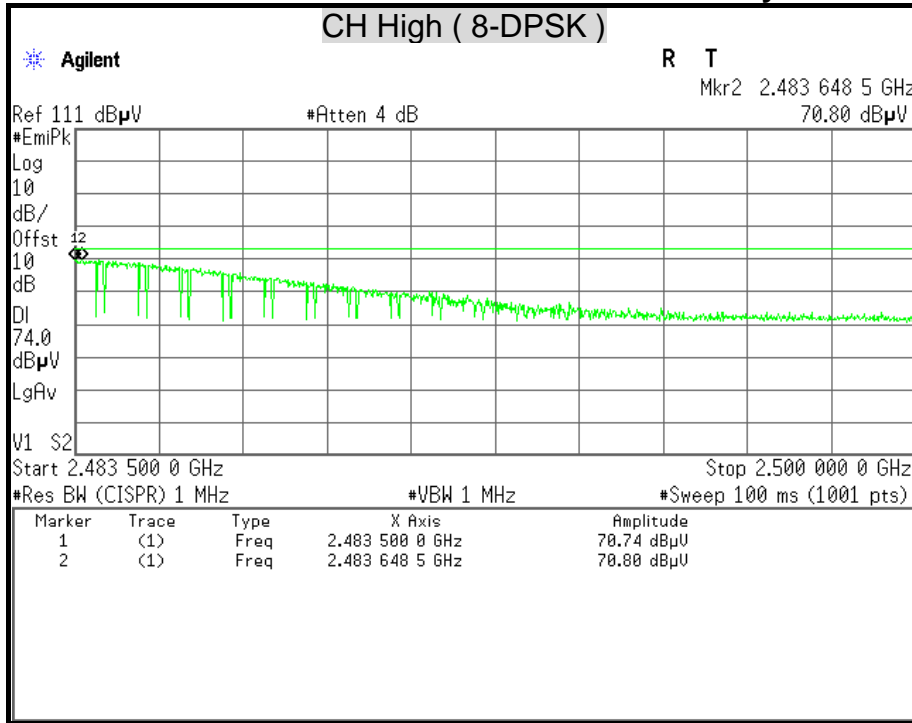

**Detector Mode : Average** **Polarity : Vertical**

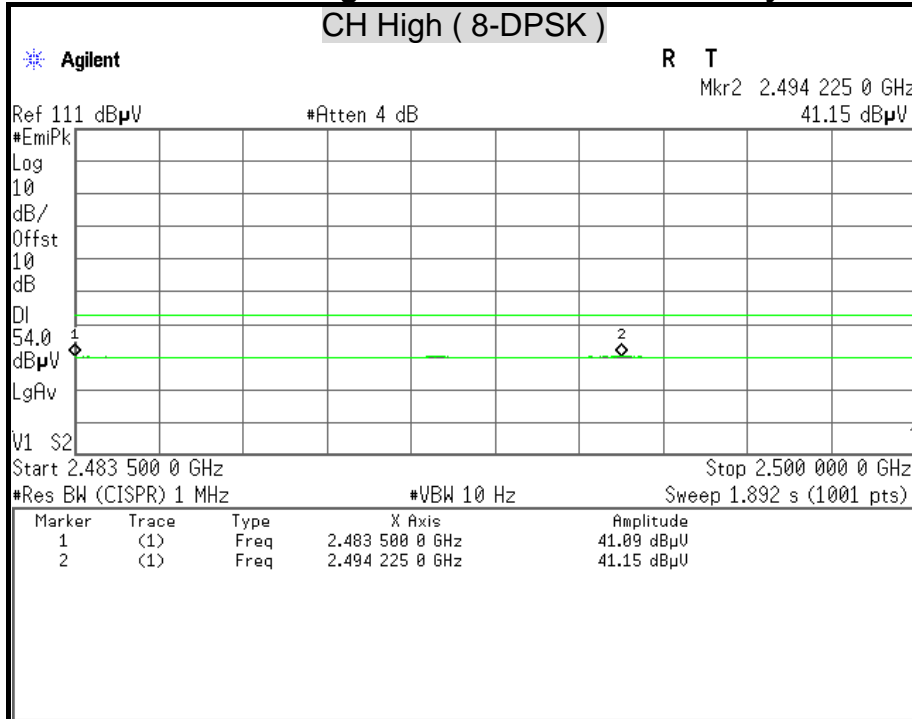

## 7.10 CONDUCTED EMISSION

### LIMITS

§ 15.207 (a) Except as shown in paragraph (b) and (c) this section, for an intentional radiator that is designed to be connected to the public utility (AC) power line, the radio frequency voltage that is conducted back onto the AC power line on any frequency or frequencies within the band 150 kHz to 30 MHz shall not exceed the limits in the following table, as measured using a 50 µH/50 ohms line impedance stabilization network (LISN). Compliance with the provisions of this paragraph shall be based on the measurement of the radio frequency voltage between each power line and ground at the power terminal. The lower limit applies at the boundary between the frequency ranges.

| Frequency Range<br>(MHz) | Conducted Limit (dBµv) |          |
|--------------------------|------------------------|----------|
|                          | Quasi-peak             | Average  |
| 0.15 - 0.50              | 66 to 56               | 56 to 46 |
| 0.50 - 5.00              | 56                     | 46       |
| 5.00 - 30.0              | 60                     | 50       |

### TEST EQUIPMENT

| Name of Equipment | Manufacturer    | Model     | Serial Number | Calibration Due |
|-------------------|-----------------|-----------|---------------|-----------------|
| L.I.S.N           | SCHWARZBECK     | NSLK 8127 | 8127465       | 08/06/2015      |
| L.I.S.N           | SCHWARZBECK     | NSLK 8127 | 8127473       | 03/09/2016      |
| EMI Test Receiver | ROHDE & SCHWARZ | ESHS 30   | 838550/003    | 11/02/2015      |
| Pulse Limiter     | ROHDE & SCHWARZ | ESH3-Z2   | 100111        | 06/30/2015      |

**Remark:** Each piece of equipment is scheduled for calibration once a year.

**TEST SETUP**

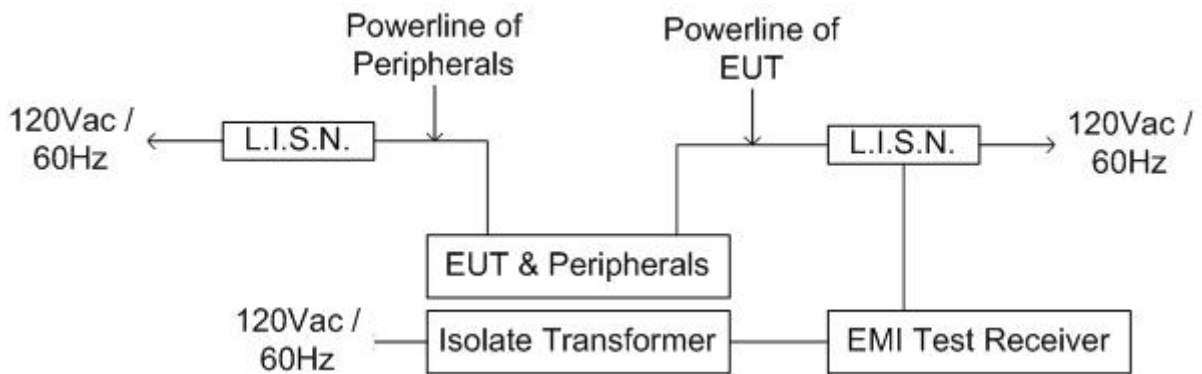
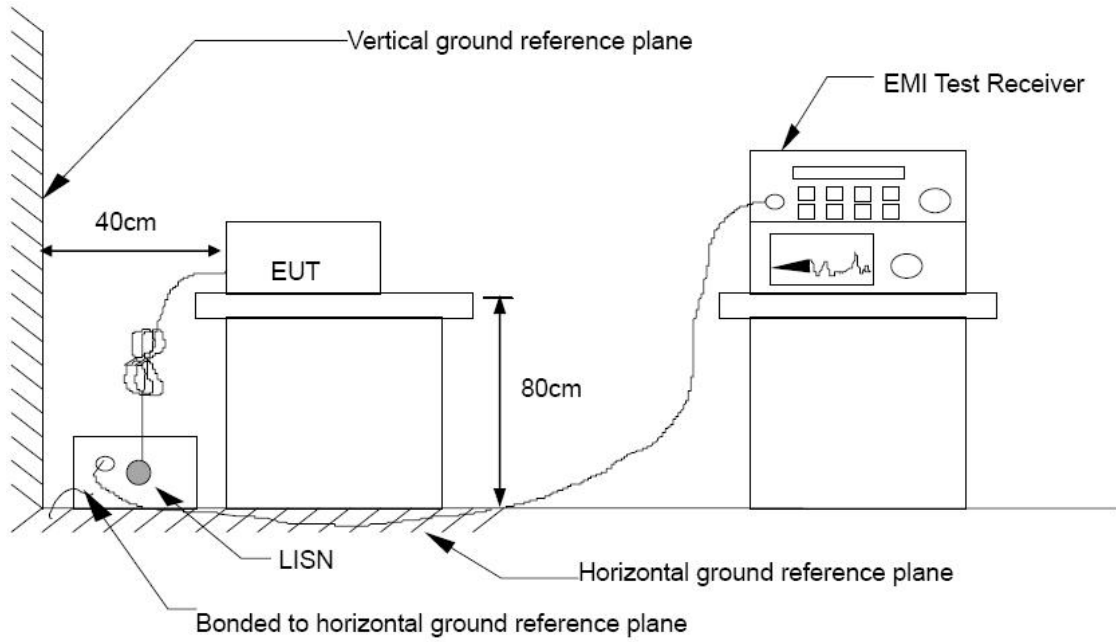

## **TEST PROCEDURE**

The basic test procedure was in accordance with ANSI C63.10:2013.

The test procedure is performed in a 4m x 3m x 2.4m (LxWxH) shielded room.

The EUT along with its peripherals were placed on a 1.0m (W) x 1.5m (L) and 0.8m in height wooden table and the EUT was adjusted to maintain a 0.4 meter space from a vertical reference plane.

The EUT was connected to power mains through a line impedance stabilization network (LISN) which provides 50 ohm coupling impedance for measuring instrument and the chassis ground was bounded to the horizontal ground plane of shielded room. All peripherals were connected to the second LISN and the chassis ground also bounded to the horizontal ground plane of shielded room.

The EUT was located so that the distance between the boundary of the EUT and the closest surface of the LISN is 0.8 m. Where a mains flexible cord was provided by the manufacturer shall be 1 m long, or if in excess of 1 m, the excess cable was folded back and forth as far as possible so as to form a bundle not exceeding 0.4 m in length.

**TEST RESULTS**

|                     |           |                             |             |
|---------------------|-----------|-----------------------------|-------------|
| <b>Product Name</b> | MX-LOCare | <b>Test By</b>              | Crystal Wu  |
| <b>Test Model</b>   | BR1       | <b>Test Date</b>            | 2015/06/16  |
| <b>Test Mode</b>    | Mode 1    | <b>Temp. &amp; Humidity</b> | 22.9°C, 44% |

**LINE**

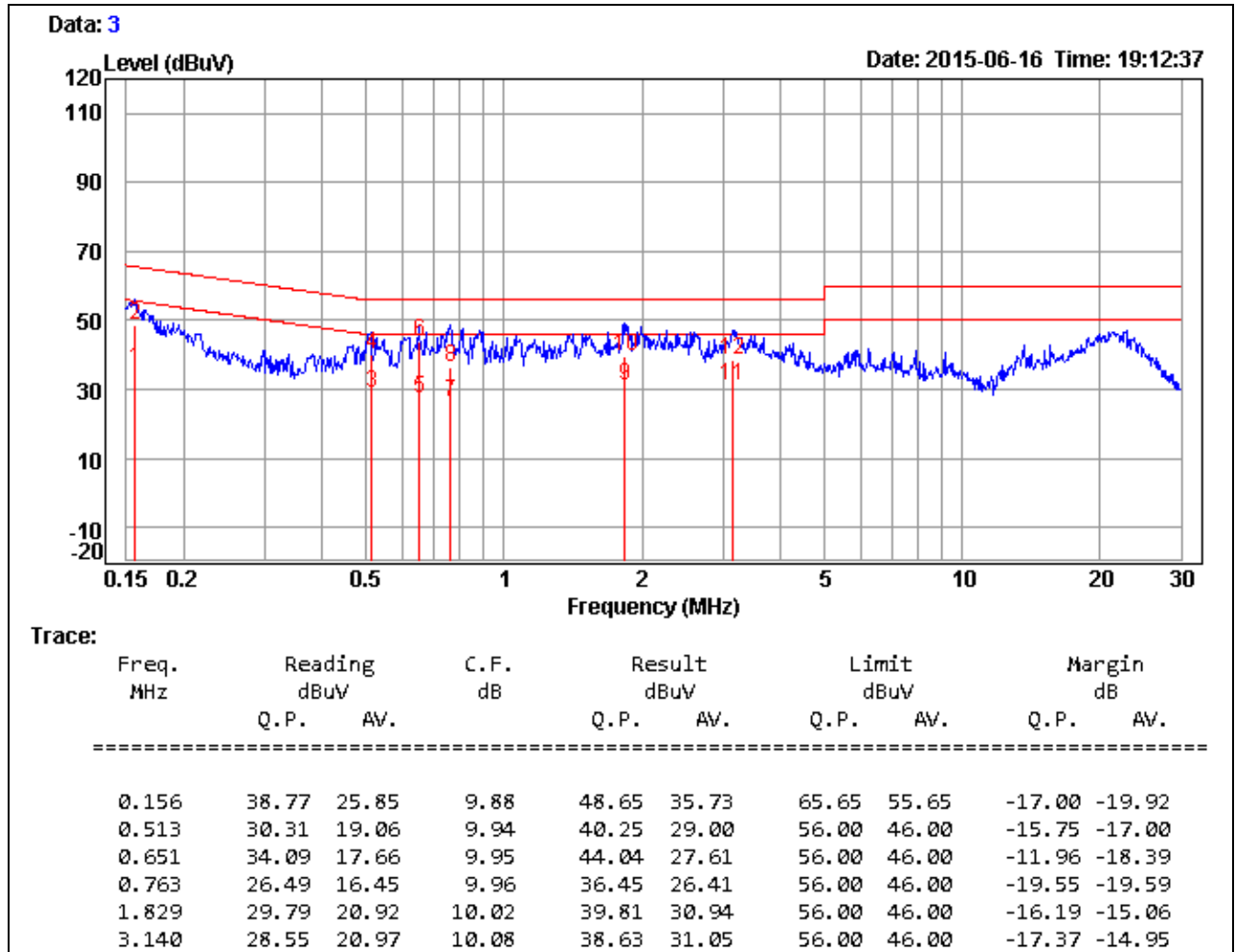

**Remark:**

1. Correction Factor = Insertion loss + Cable loss
2. Emission level = Reading Value + Correction factor
3. Margin value = Emission level – Limit value

|                     |           |                             |             |
|---------------------|-----------|-----------------------------|-------------|
| <b>Product Name</b> | MX-LOCare | <b>Test By</b>              | Crystal Wu  |
| <b>Test Model</b>   | BR1       | <b>Test Date</b>            | 2015/06/16  |
| <b>Test Mode</b>    | Mode 1    | <b>Temp. &amp; Humidity</b> | 22.9°C, 44% |

**NEUTRAL**

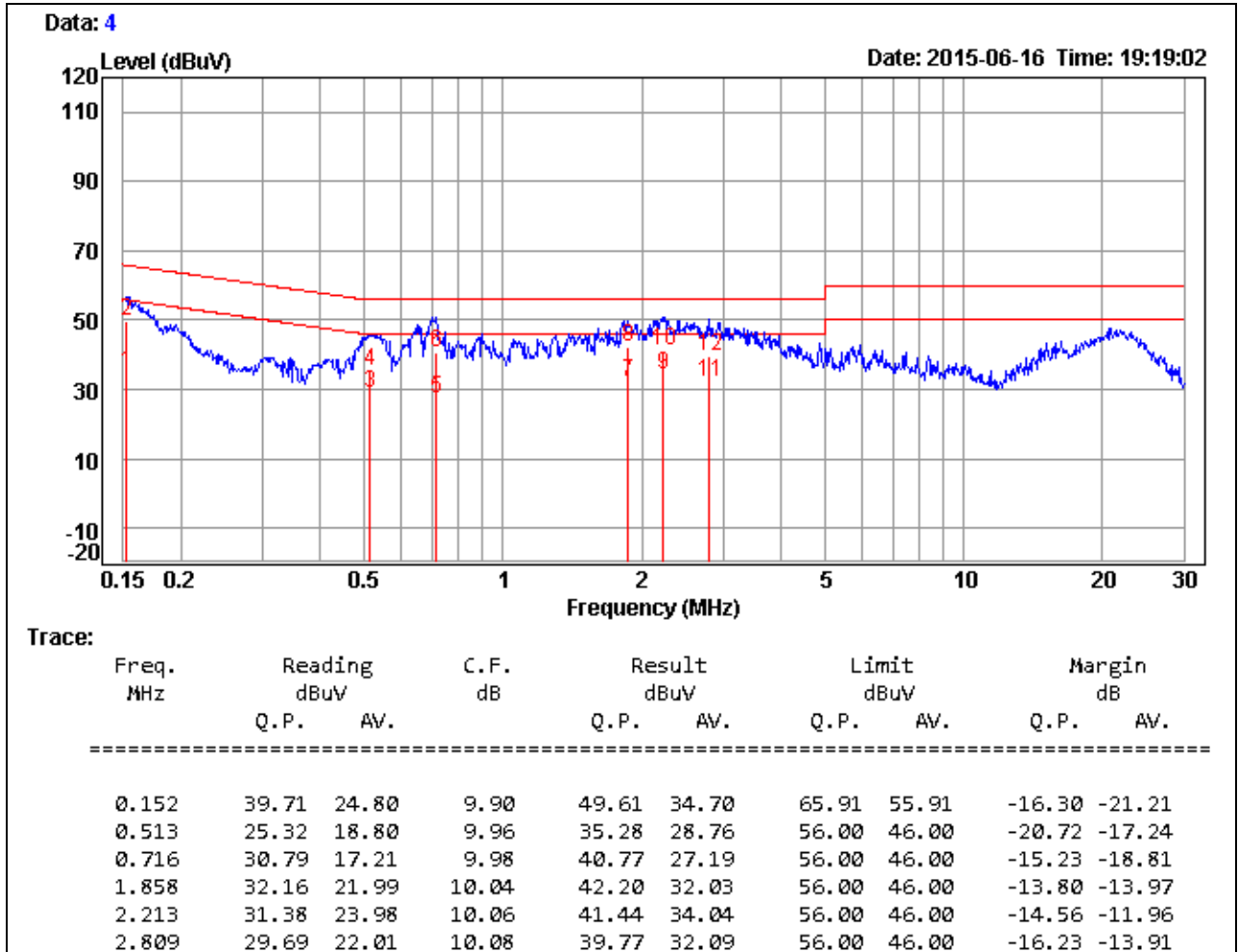

**Remark:**

1. Correction Factor = Insertion loss + Cable loss
2. Emission level = Reading Value + Correction factor
3. Margin value = Emission level – Limit value