

FCC PART 15 SUBPART C MEASUREMENT AND TEST REPORT

For

SHENZHEN HOMELEAD ELECTRONICS CO., LTD.

**6/F Building A, Fengtian Innovation and Technology Industrial Park, Dahe
Road, Longhua, Shenzhen, China**

E.U.T.: Wireless Doorbell

Model Name: HD01, HD02, HD03, HD04, HD05, HD06, HD07, HD08

Brand Name: N/A

FCC ID: 2AAXFHD160108

Report Number: NTC1706408FV00

Test Date(s): June 20, 2017 to July 10, 2017

Report Date(s): July 10, 2017

Prepared by

Dongguan NTC Co., Ltd.

**Building D, Gaosheng Science and Technology Park, Hongtu Road,
Nancheng District, Dongguan City, Guangdong, China**

Tel: +86-769-22022444

Fax: +86-769-22022799

Prepared By

Approved & Authorized Signer



Rose Hu / Engineer



Sunm Lv / Q.A. Director

Note: This test report is for the customer shown above and their specific product only. It may not be duplicated or used in part without prior written consent from Dongguan NTC Co., Ltd. The test results referenced from this report are relevant only to the sample tested.



Table of Contents

1. GENERAL INFORMATION	3
1.1 PRODUCT DESCRIPTION FOR EQUIPMENT UNDER TEST	3
1.2 RELATED SUBMITTAL(S) / GRANT (S).....	4
1.3 TEST METHODOLOGY.....	4
1.4 EQUIPMENT MODIFICATIONS.....	4
1.5 SUPPORT DEVICE	4
1.6 TEST FACILITY AND LOCATION	4
1.7 SUMMARY OF TEST RESULTS.....	5
2. RADIATED EMISSION TEST	6
2.1 TEST SET-UP (BLOCK DIAGRAM OF CONFIGURATION)	6
2.2 MEASUREMENT PROCEDURE.....	7
2.3 LIMIT	8
2.4 MEASUREMENT RESULTS	10
3. OCCUPIED BANDWIDTH	14
3.1 MEASUREMENT PROCEDURE	14
3.2 TEST SET-UP (BLOCK DIAGRAM OF CONFIGURATION).....	14
3.3 LIMIT.....	14
3.4 MEASUREMENT RESULTS	14
4. TRANSMISSION TIME	16
4.1 MEASUREMENT PROCEDURE	16
4.2 TEST SET-UP (BLOCK DIAGRAM OF CONFIGURATION).....	16
4.3 LIMIT	16
4.4 MEASUREMENT RESULTS	16
5. ANTENNA APPLICATION	18
5.1 ANTENNA REQUIREMENT.....	18
5.2 MEASUREMENT RESULTS	18
6. TEST EQUIPMENT LIST.....	19

1. GENERAL INFORMATION

1.1 Product Description for Equipment under Test

This device is a Wireless Doorbell which is powered by 12V battery. For more details features, please refer to User's Manual.

Manufacturer/ Factory	: SHENZHEN HOMELEAD ELECTRONICS CO., LTD.
Address	: 6/F Building A, Fengtian Innovation and Technology Industrial Park, Dahe Road, Longhua, Shenzhen, China
Frequency:	: 433.92MHz
Modulation	: ASK
Antenna Type	: PCB
Antenna Gain	: 2.15dBi
Number of Channels	: 1
Power supply	: DC 12V Battery (Battery's model name is 23A)
Model name	: HD01, HD02, HD03, HD04, HD05, HD06, HD07, HD08 (We prepare HD01 for EMC test.)
Model difference	: These models have the same circuitry, PCB layout, electrical mechanical and physical construction. Their differences in model number due to trading purpose.

1.2 Related Submittal(s) / Grant (s)

This submittal(s) (test report) is intended for FCC ID: 2AAXFHD160108 filing to comply with Section 15.231 of the FCC Part 15 (2014), Subpart C Rule.

1.3 Test Methodology

The radiated emission measurement was performed according to the procedures in ANSI C63.10 (2013). Radiated emission measurement was performed in semi-anechoic chamber. For radiated emission measurement, preliminary scans were performed in the semi-anechoic chamber only to determine the worst case modes. All radiated tests were performed at an antenna to EUT distance of 3 meters.

1.4 Equipment Modifications

Not available for this EUT intended for grant.

1.5 Support Device

None

1.6 Test Facility and Location

Listed by FCC, July 03, 2014
The Certificate Registration Number is 665078.
Listed by Industry Canada, June 18, 2014
The Certificate Registration Number is 9743A.

Dongguan NTC Co., Ltd.
(Full Name: Dongguan Nore Testing Center Co., Ltd.)

Building D, Gaosheng Science and Technology Park, Hongtu Road,
Nancheng District, Dongguan City, Guangdong, China
(Full Name: Building D, Gaosheng Science & Technology Park,
Zhouxi Longxi Road, Nancheng District, Dongguan, Guangdong, China.

1.7 Summary of Test Results

FCC Rules	Description Of Test	Result
§15.207	AC Power Conducted Emission	N/A ^{see note 2}
§15.231&15.209	Radiated Emission	Compliant
§15.231(c)	Occupied bandwidth	Compliant
§15.231(a)	Transmission time	Compliant
§15.203	Antenna Requirement	Compliant

- Note: 1. The EUT has been tested as an independent unit. And Continual transmitting in maximum power (The new battery be used during test)
2. Due to this EUT is powered by battery only, the AC Power Conducted Emission is not applicable.
3. The EUT powered by battery and operating multiple positions, so the EUT shall be performed two or three orthogonal planes. The worst plane is Z.

Example:

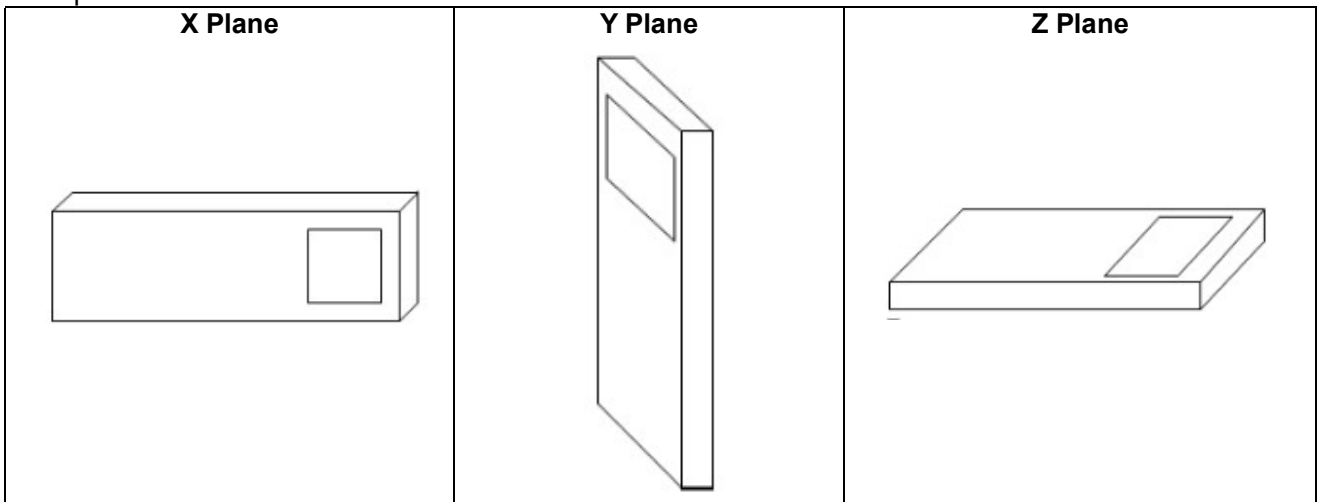

2. Radiated Emission Test

2.1 Test SET-UP (Block Diagram of Configuration)

(1) Radiated Emission Test Set-Up, Frequency Below 30MHz

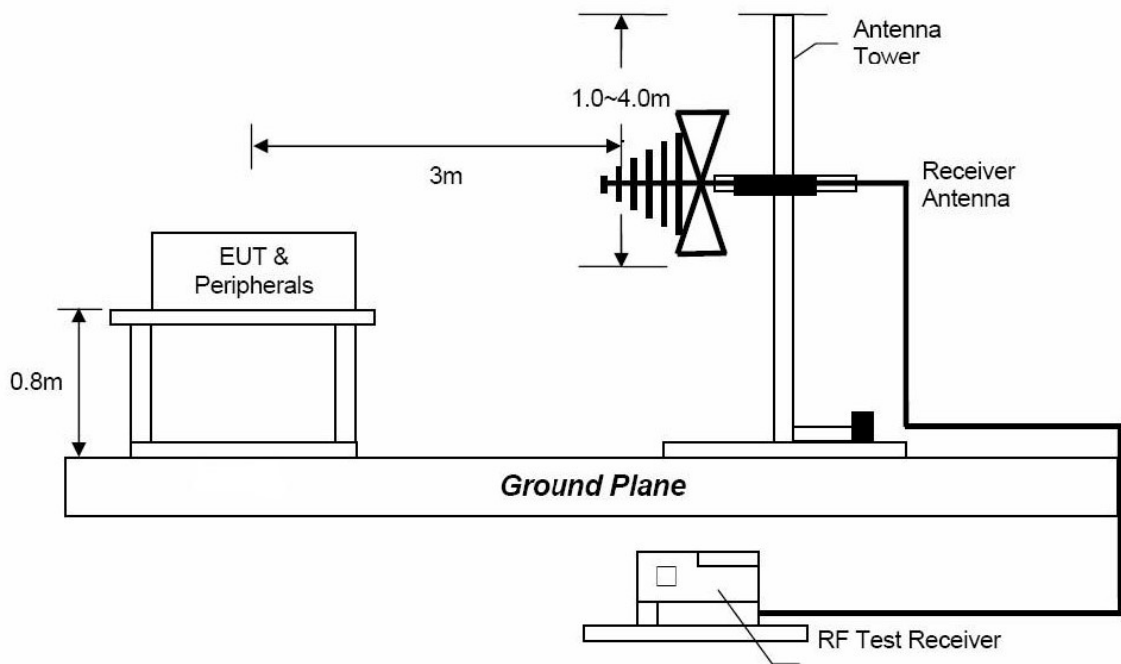
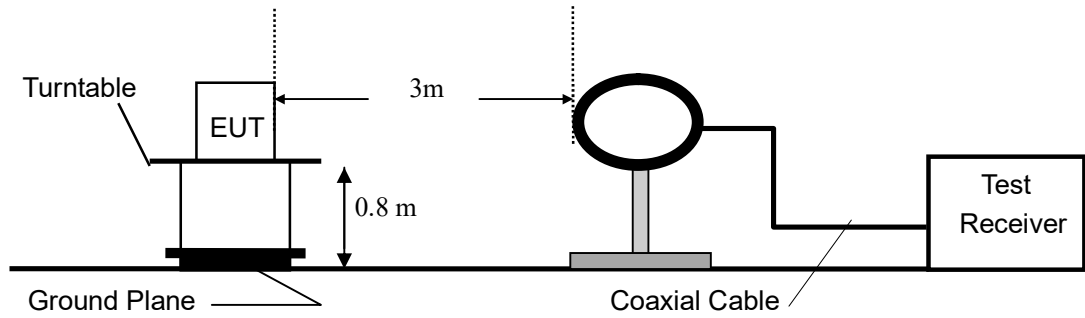

(2) Radiated Emission Test Set-Up, Frequency above 1GHz

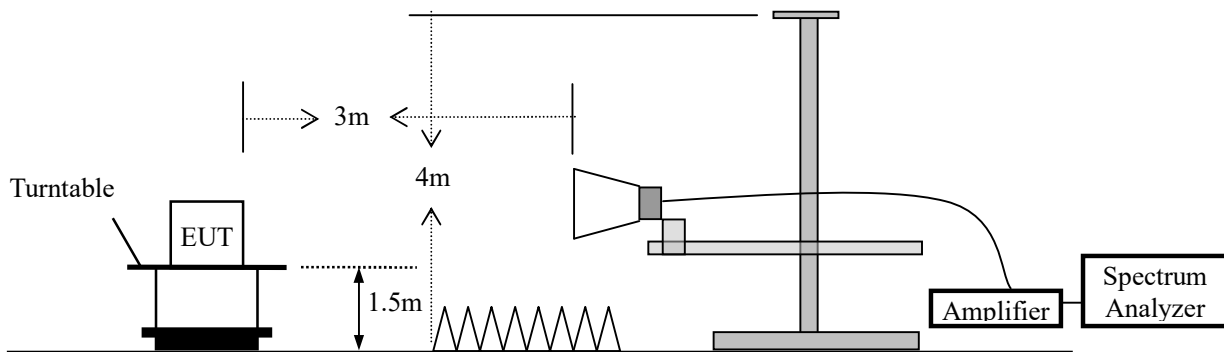

2.2 Measurement Procedure

- Blow 1GHz, the EUT was placed on the top of a rotating table 0.8 meters above the ground at a 3 meter semi- anechoic chamber room. Above 1GHz, the EUT was placed on the top of a rotating table 1.5 meters above the ground at a 3 meter full anechoic chamber room. The table was rotated 360 degrees to determine the position of the highest radiation.
- The EUT was set 3 meters away from the interference-receiving antenna, which was mounted on the top of a variable-height antenna tower.
- The height of antenna is varied from one meter to four meters above the ground to determine the maximum value of the field strength. Both horizontal and vertical polarizations of the antenna are set to make the measurement.
- For each suspected emission, the EUT was arranged to its worst case and then the antenna was tuned to heights from 1 meter to 4 meters and the rotatable table was turned from 0 degrees to 360 degrees to find the maximum reading. The test-receiver system was set to peak detect function and specified bandwidth with maximum hold mode.
- A Quasi-peak measurement was then made for that frequency point for below 1GHz test. PK and AV for above 1GHz emission test.

For 30MHz to 1GHz:

Sept the spectrum analyzer as: RBW=120kHz, VBW=300kHz, Detector=Quasi-Peak

For Above 1GHz:

Set the spectrum analyzer as: RBW=1MHz, VBW=3MHz, Detector=Peak.

Set the spectrum analyzer as: RBW=1MHz, VBW=10Hz, Detector=Peak.

During the radiated emission test, the spectrum analyzer was set with the following configurations:

Frequency Band (MHz)	Level	Resolution Bandwidth	Video Bandwidth
30 to 1000	QP	120 kHz	300 kHz
Above 1000	Peak	1 MHz	3 MHz
	Average	Peak+ AV Factor	

2.3 Limit

Table A [0.009MHz~1GHz]

Frequency range MHz	Distance Meters	Field Strengths Limit (15.209)
		μV/m
0.009 ~ 0.490	300	2400/F(kHz)
0.490 ~ 1.705	30	24000/F(kHz)
1.705 ~ 30	30	30
30 ~ 88	3	100
88 ~ 216	3	150
216 ~ 960	3	200
Above 960	3	500

- Remark :
- (1) Emission level (dB)μV = 20 log Emission level μV/m
 - (2) The smaller limit shall apply at the cross point between two frequency bands.
 - (3) As shown in 15.35(b), for frequencies above 1000MHz, the field strength limits are based on average detector, however, the peak field strength of any emission shall not exceed the maximum permitted average limits, specified above by more than 20dB under any condition of modulation.
 - (4) The frequency range scanned is from the lowest radio frequency signal generated in the device which is greater than 9 kHz to the tenth harmonic of the highest fundamental frequency or 40 GHz, whichever is lower.



Table B

Fundamental Frequency (MHz)	Field Strength of Fundamental		Field Strength of Spurious Emissions	
	$\mu\text{V/m}$	$\text{dB}\mu\text{V/m}$	$\mu\text{V/m}$	$\text{dB}\mu\text{V/m}$
40.66-40.70	2250	67.04	225	47.04
70-130	1250	61.94	125	41.94
130-174	1250-3370**	61.9-70.55	125-375**	41.94-51.48
174-260	3750	71.48	375	51.48
260-470	3750-12500**	71.48-81.94	375-1250**	51.48-61.94
Above 470	12500	81.94	1250	61.94

**) Linear interpolations



2.4 Measurement Results

For Spurious Emission.

Frequency range: 9KHz~1GHz
 Operation Mode: TX
 Test Result: PASS
 Measured Distance: 3m
 Test Date : June 25, 2017

Temperature : 22 °C
 Humidity : 48 %
 Test By: Steven

Freq. (MHz)	Ant.Pol. H/V	Reading Level (dBuV)	Factor (dB/m)	Emission Level (dBuV/m)	Limit 3m (dBuV/m)	Margin (dB)	Note
68.3800	V	38.67	-16.18	22.49	40.00	-17.51	QP
155.5000	V	38.22	-15.22	23.00	43.50	-20.50	QP

80.1400	H	36.33	-16.08	20.25	40.00	-19.75	QP
199.3500	H	39.14	-14.98	24.16	43.50	-19.34	QP

Other emissions are lower than 20dB below the allowable limit. And according to FCC rule, they had not recorded in the report.

- Note:**
- (1) Emission Level= Reading Level + Factor
 - (2) Factor= Antenna Gain + Cable Loss – Amplifier Gain
 - (3) Measurement uncertainty : ±3.4dB
 - (4) Loop antenna used for the emission below 30MHz.
 - (5) Data of measurement within this frequency range shown “ ---” in the table above means the reading of emissions are attenuated more than 10dB below the permissible limits.



For Fundamental radiation, Harmonic radiation.

Frequency range: 30MHz~5GHz
 Operation Mode: TX
 Test Result: PASS
 Measured Distance: 3m
 Test Date : June 25, 2017
 Temperature : 22 °C
 Humidity : 48 %
 Test By: Steven

Freq. (MHz)	Ant.Pol. H/V	Reading Level (dBuV)	Factor (dB/m)	Emission Level (dBuV/m)	Limit 3m (dBuV/m)	Margin (dB)	Note
433.920	V	95.33	-12.05	83.28	100.8	-17.52	peak
433.920	V	--	--	69.98	80.8	-10.82	AV
868.080	V	50.73	-1.13	49.60	80.8	-31.20	peak
868.080	V	--	--	36.30	60.8	-24.50	AV
1736.000	V	59.51	1.60	61.11	80.8	-19.69	peak
1736.000	V	--	--	47.81	60.8	-12.99	AV

433.920	H	81.18	-12.05	69.13	100.8	-31.67	peak
433.920	H	--	--	55.83	80.8	-24.97	AV
868.080	H	45.61	-1.13	44.48	80.8	-36.32	peak
868.080	H	--	--	31.18	60.8	-29.62	AV
1736.000	H	48.55	1.60	50.15	80.8	-30.65	peak
1736.000	H	--	--	36.85	60.8	-23.95	AV

Other emissions are lower than 20dB below the allowable limit. And according to FCC rule, they had not recorded in the report.

- Note:**
- (1) Emission Level= Reading Level+Probe Factor +Cable Loss
 - (2) Factor= Antenna Gain + Cable Loss – Amplifier Gain
 - (3) Measurement uncertainty: ±3.7dB
 - (4) Emission (the row indicated by bold) within the restricted band meets the requirement of FCC part 15 Section 15.205.
 - (5) Horn antenna used for the emission over 1000MHz.

For Duty Cycle

Average should be determined by duty cycle factor.
 The duty cycle is simply the on time by divided by the period:
 The duration of one cycle = 23.0769ms <50ms
 Effective period of the cycle =
 $Ton1 * Number + Ton2 * Number = 0.240 * 11 + 1.362 * 6 = 10.812ms$
 Duty cycle = $10.812ms / 50ms = 0.2162ms$

AV Factor = $20 \log 0.2162 = -13.30$

The value of Average = The value of Peak + AV Factor.

Example: For 433.92MHz, AV = 83.28(Peak) - 13.30(AV factor) = 69.98.
 Details please see the following plots.

The duration of one cycle

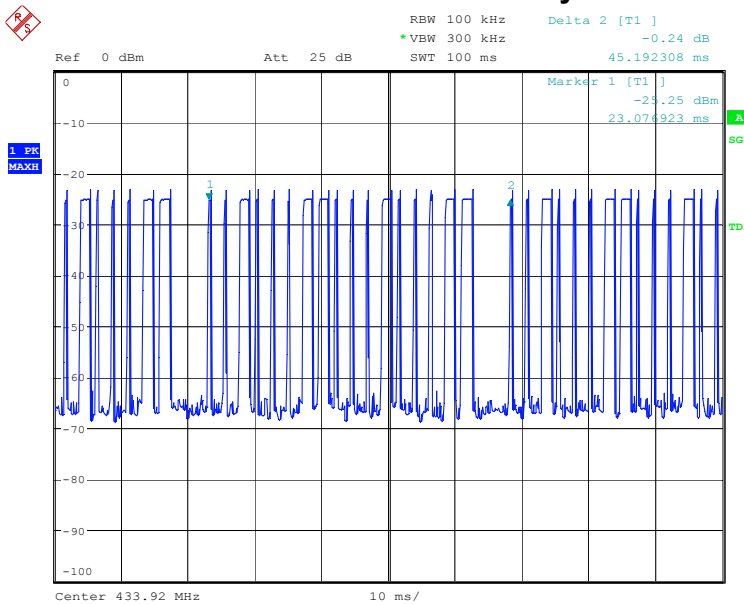

6 long signals

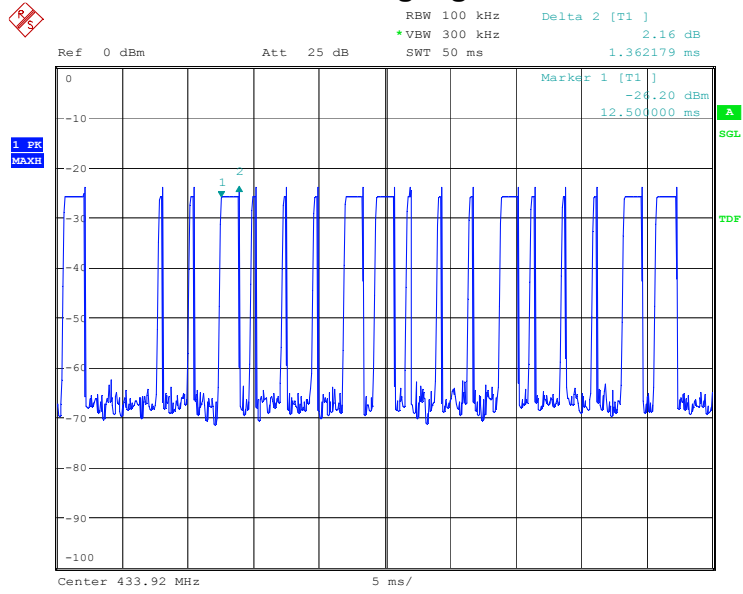

11 short signals

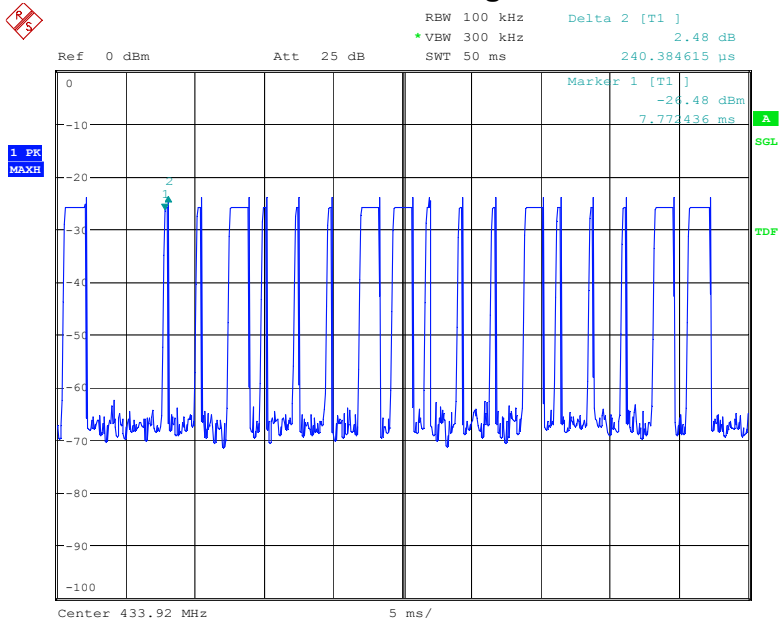



3. Occupied Bandwidth

3.1 Measurement Procedure

Same as section 2.2.

3.2 Test SET-UP (Block Diagram of Configuration)

Same as section 2.1.

3.3 Limit

Please refer section 15.231

According to 15.231(C), the bandwidth of the emission shall be no wider than 0.25% of the center frequency for devices operating above 70MHz and below 900MHz.

$$\text{Limit} = 433.92 * 0.25\% = 1.08 \text{ MHz}$$

3.4 Measurement Results

20dB Bandwidth	Limit
149.04KHz	1.08MHz

Please refer to the following plot.

20dB Bandwidth

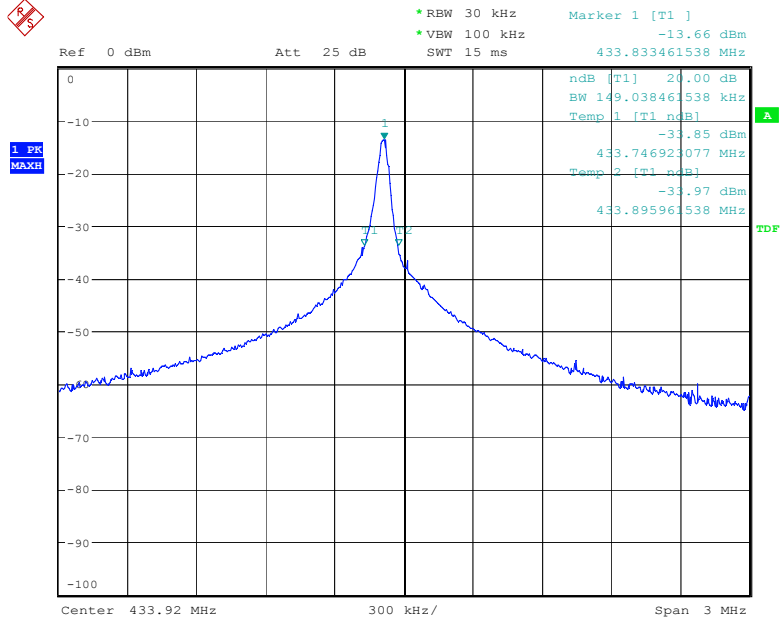

4 Transmission Time

4.1 Measurement Procedure

Same as section 2.2.

4.2 Test SET-UP (Block Diagram of Configuration)

Same as section 2.1.

4.3 Limit

According to 15.231(a)(1), A manually operated transmitter shall employ a switch that will automatically deactivate the transmitter within not more than 5 seconds of being released.

4.4 Measurement Results

Transmission Time	Limit
1.298s	5s

Please refer to the following plot.

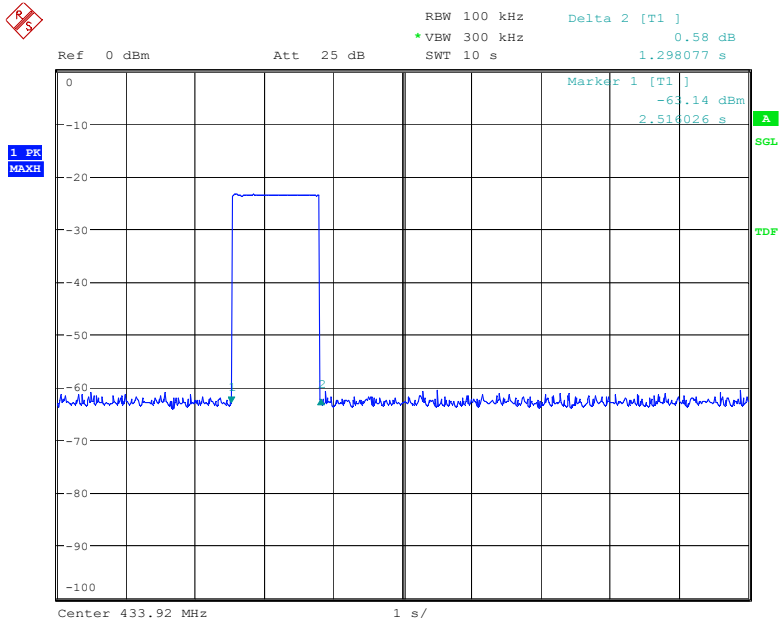

5. Antenna Application

5.1 Antenna requirement

According to of FCC part 15C section 15.203 and 15.240:

An intentional radiator shall be designed to ensure that no antenna other than that furnished by the responsible party shall be used with the device. The use of a permanently attached antenna or of an antenna that uses a unique coupling to the intentional radiator, the manufacturer may design the unit so that a broken antenna can be replaced by the user, but the use of a standard antenna jack or electrical connector is prohibited.

5.2 Measurement Results

The antenna is integrated on the main PCB and no consideration of replacement, and the best case gain of the antenna is 2.15dBi. So, the antenna is consider meet the requirement.

6. Test Equipment List

Description	Manufacturer	Model Number	Serial Number	Characteristics	Calibration Date	Calibration Due Date
Test Receiver	Rohde & Schwarz	ESCI7	100837	9KHz~7GHz	Nov. 23, 2016	Nov. 22, 2017
Antenna	Schwarzbeck	VULB9162	9162-010	30MHz~7GHz	Nov. 26, 2016	Nov. 25, 2017
Positioning Eight keys remote for laser light	UC	UC 3000	N/A	0~360°, 1-4m	N/A	N/A
Color Monitor	SUNSP0	SP-140A	N/A	N/A	N/A	N/A
Single Phase Power Line Filter	SAEMC	PF201A-32	110210	32A	N/A	N/A
3 Phase Power Line Filter	SAEMC	PF401A-200	110318	200A	N/A	N/A
DC Power Filter	SAEMC	PF301A-200	110245	200A	N/A	N/A
Cable	Huber+Suhner	CBL2-NN-1M	22390001	9KHz~7GHz	Nov. 07, 2016	Nov. 06, 2017
Cable	Huber+Suhner	CIL02	N/A	9KHz~7GHz	Nov. 07, 2016	Nov. 06, 2017
RF Cable	Huber+Suhner	SF-104	MY16559/4	9KHz~25GHz	Mar. 06, 2017	Mar. 05, 2018
Power Amplifier	HP	HP 8447D	1145A00203	100KHz~1.3GHz	Nov. 07, 2016	Nov. 06, 2017
Horn Antenna	Com-Power	AH-118	071078	1GHz~18GHz	Nov. 05, 2016	Nov. 04, 2017
Loop antenna	Daze	ZA30900A	0708	9KHz~30MHz	Oct.10, 2016	Oct.09, 2017
Pre-Amplifier	Agilent	8449B	3008A02964	1GHz~26.5GHz	Nov. 03, 2016	Nov. 02, 2017
Temporary antenna connector	TESCOM	SS402	N/A	1G-18GHz	N/A	N/A

Note: The temporary antenna connector is soldered on the PCB board in order to perform conducted tests and this temporary antenna connector is listed in the equipment list.

---End---