

## FCC 47 CFR PART 15 SUBPART E

Product Type : Play-Fi Player  
Applicant : Phorus, Inc.  
Address : 16255 Ventura Boulevard, Suite 310, Encino, United States,  
91436  
Trade Name : Phorus  
Model Number : PS2 Speaker  
Test Specification : FCC 47 CFR PART 15 SUBPART E: Oct., 2012  
Canada RSS-210 ISSUE 8: Dec., 2010  
Canada RSS-Gen ISSUE 3: Dec., 2010  
ANSI C63.4-2009  
Application Purpose : Original  
Receive Date : Apr. 18, 2013  
Test Period : Apr. 29 ~ 03, 2013  
Issue Date : Sep. 03, 2013

### Issue by

A Test Lab Techno Corp.  
No. 140-1, Changan Street, Bade City,  
Taoyuan County 334, Taiwan R.O.C.  
Tel : +86-3-2710188 / Fax : +86-3-2710190



Taiwan Accreditation Foundation accreditation number: 1330

**Note:** This report shall not be reproduced except in full, without the written approval of A Test Lab Techno Corp. This document may be altered or revised by A Test Lab Techno Corp. personnel only, and shall be noted in the revision section of the document. The client should not use it to claim product endorsement by TAF, or any government agencies. The test results in the report only apply to the tested sample.

**Revision History**

<b>Rev.</b>	<b>Issue Date</b>	<b>Revisions</b>	<b>Revised By</b>
00	Sep. 03, 2013	Initial Issue	

## Verification of Compliance

Issued Date: 09/03/2013

Product Type : Play-Fi Player  
Applicant : Phorus, Inc.  
Address : 16255 Ventura Boulevard, Suite 310, Encino, United States, 91436  
Trade Name : Phorus  
Model Number : PS2 Speaker  
FCC ID : 2AAWQ-PS2SPEAKER  
IC : 11138A-PS2SPEAKER  
EUT Rated Voltage : DC 12V, 2A  
Test Voltage : 120 Vac / 60 Hz  
Applicable Standard : FCC 47 CFR PART 15 SUBPART E: Oct., 2012  
Canada RSS-210 ISSUE 8: Dec., 2010  
Canada RSS-Gen ISSUE 3: Dec., 2010  
ANSI C63.4-2009  
Test Result : Complied  
Application Purpose : Original  
Performing Lab. : A Test Lab Techno Corp.

No. 140-1, Changan Street, Bade City,  
Taoyuan County 334, Taiwan R.O.C.

Tel : +86-3-2710188 / Fax : +86-3-2710190

Taiwan Accreditation Foundation accreditation number:  
1330



<http://www.atl-lab.com.tw/e-index.htm>

The above equipment was tested by A Test Lab Techno Corp. The test data, data evaluation, test procedures, and equipment configurations shown in this report were made in accordance with the procedures given in ANSI C63.4: 2009 and the energy emitted by the sample tested as described in this report is in compliance with the requirements of FCC Rules Part 15.203, 15.407 .

The test results of this report relate only to the tested sample identified in this report.

Approved By : 

(Manager)

(Murphy Wang)

Reviewed By : 

(Testing Engineer)

(Fly Lu)

## TABLE OF CONTENTS

1	General Information.....	6
2	EUT Description .....	7
3	Test Methodology .....	8
	3.1. Mode of Operation.....	8
	3.2. EUT Exercise Software .....	9
	3.3. Configuration of Test System Details.....	9
	3.4. Test Site Environment .....	11
4	AC Power Conducted Emission Measurement.....	12
	4.1. Limit.....	12
	4.2. Test Instruments .....	12
	4.3. Test Setup .....	12
	4.4. Test Procedure .....	13
	4.5. Test Result.....	14
5	Radiated Emission Measurement.....	16
	5.1. Limit.....	16
	5.2. Test Instruments .....	16
	5.3. Setup.....	17
	5.4. Test Procedure .....	19
	5.5. Test Result.....	21
6	Maximum Conducted Output Power / EIRP Measurement.....	54
	6.1. Limit.....	54
	6.2. Test Setup .....	54
	6.3. Test Instruments .....	54
	6.4. Test Procedure .....	54
	6.5. Test Result.....	55
7	26dB RF Bandwidth Measurement.....	58
	7.1. Limit.....	58
	7.2. Test Setup .....	58
	7.3. Test Instruments .....	58
	7.4. Test Procedure .....	58
	7.5. Test Result.....	59
	7.6. Test Graphs .....	61

8	Peak Power Excursion Measurement .....	70
8.1.	Limit.....	70
8.2.	Test Setup .....	70
8.3.	Test Instruments .....	70
8.4.	Test Procedure .....	70
8.5.	Test Result.....	71
8.6.	Test Graphs .....	73
9	Peak Power Spectral Density Measurement .....	82
9.1.	Limit.....	82
9.2.	Test Setup .....	82
9.3.	Test Instruments .....	82
9.4.	Test Procedure .....	82
9.5.	Test Result.....	83
9.6.	Test Graphs .....	85
10	Frequency Stability Measurement .....	94
10.1.	Limit.....	94
10.2.	Test Setup .....	94
10.3.	Test Instruments .....	94
10.4.	Test Procedure .....	95
10.5.	Test Result.....	95
11	Antenna Measurement .....	103
11.1.	Limit.....	103
11.2.	Antenna Connector Construction .....	103

## 1 General Information

### 1.1 Summary of Test Result

Standard	Item	Result	Remark
15.407(b)(5)	AC Power Conducted Emission	PASS	Meet the requirement of limit.
15.407(b/1/2/3) (b)(5)	Radiated Emission	PASS	Meet the requirement of limit.
15.407(a/1/2/3)	Maximum Conducted Output Power	PASS	Meet the requirement of limit.
---	26dB RF Bandwidth	Reference	---
15.407(a)(6)	Peak Power Excursion	PASS	Meet the requirement of limit.
15.407(a/1/2/3)	Peak Power Spectral Density	PASS	Meet the requirement of limit.
15.407(g)	Frequency Stability	PASS	Meet the requirement of limit.
15.203	Antenna Requirement	PASS	Meet the requirement of limit.

The test results of this report relate only to the tested sample(s) identified in this report. Manufacturer or whom it may concern should recognize the pass or fail of the test result.

### 1.2 Measurement Uncertainty

#### Conducted Emission

The measurement uncertainty is evaluated as  $\pm 2.02$  dB.

#### Radiated Emission

The measurement uncertainty is evaluated as  $\pm 3.96$  dB for horizontal in 30MHz ~ 1000MHz.

The measurement uncertainty is evaluated as  $\pm 3.57$  dB for vertical in 30MHz ~ 1000MHz.

The measurement uncertainty is evaluated as  $\pm 3.072$  dB for horizontal in 1000MHz ~ 18000MHz.

The measurement uncertainty is evaluated as  $\pm 3.028$  dB for vertical in 1000MHz ~ 18000MHz.

The measurement uncertainty is evaluated as  $\pm 3.622$  dB for horizontal in 18000MHz ~ 40000MHz.

The measurement uncertainty is evaluated as  $\pm 3.506$  dB for vertical in 18000MHz ~ 40000MHz.

This uncertainty represents an expanded uncertainty expressed at approximately the 95% confidence level using a coverage factor of  $k = 2$ .

## 2 EUT Description

Product Type	Play-Fi Player				
Trade Name	Phorus				
Model No.	PS2 Speaker				
Applicant	Phorus, Inc. 16255 Ventura Boulevard, Suite 310, Encino, United States, 91436				
Manufacturer	Wistron InfoComm (Zhongshan) Corporation Linhai Branch Xiyiwei, Ma'an Cun, Zhongshan Torch Development Zone, Zhongshan City, Guangdong, China				
FCC ID	2AAWQ-PS2SPEAKER				
IC	11138A-PS2SPEAKER				
Frequency Range	Band	Mode	Frequency Range (MHz)	Number of Channels	
	U-NII Band I	IEEE 802.11a	5180 – 5240	4 Channels	
		IEEE 802.11n 20 MHz	5180 – 5240	4 Channels	
		IEEE 802.11n 40 MHz	5190 – 5230	2 Channels	
	U-NII Band II	IEEE 802.11a	5260 – 5320	4 Channels	
		IEEE 802.11n 20 MHz	5260 – 5320	4 Channels	
		IEEE 802.11n 40 MHz	5270 – 5310	2 Channels	
	U-NII Band III	IEEE 802.11a	5500 – 5700	11 Channels	
		IEEE 802.11n 20 MHz	5500 – 5700	11 Channels	
IEEE 802.11n 40 MHz		5510 – 5670	5 Channels		
Modulation Type	IEEE 802.11a U-NII Band I/Band II/Band III: OFDM IEEE 802.11n 20MHz U-NII Band I/Band II/Band III: OFDM IEEE 802.11n 40MHz U-NII Band I/Band II/Band III: OFDM				
Antenna Type	PIFA antenna				
Antenna Used	Item	Antenna	Type	Band	Max. Gain
	1	Main ANT (ANTL)	PIFA	IEEE 802.11a / IEEE 802.11n (5GHz) 20MHz / 40MHz	4.07 dBi
	2	Aux ANT (ANTR)	PIFA	IEEE 802.11a / IEEE 802.11n (5GHz) 20MHz / 40MHz	5.38 dBi
Antenna Delivery	1*Tx + 1*Rx				
RF Output Power / EIRP	Band	RF Conducted Output Power (W)		EIRP (W)	
EIRP	IEEE 802.11a U-NII Band I	0.149		0.080	
	IEEE 802.11a U-NII Band II	0.147		0.077	
	IEEE 802.11a U-NII Band III	0.126		0.056	
	IEEE 802.11n 20MHz U-NII Band I	0.116		0.056	
	IEEE 802.11n 20MHz U-NII Band II	0.107		0.051	
	IEEE 802.11n 20MHz U-NII Band III	0.082		0.036	
	IEEE 802.11n 40MHz U-NII Band I	0.110		0.047	
	IEEE 802.11n 40MHz U-NII Band II	0.098		0.046	
	IEEE 802.11n 40MHz U-NII Band III	0.096		0.046	

### 3 Test Methodology

#### 3.1. Mode of Operation

Decision of Test ATL has verified the construction and function in typical operation. All the test modes were carried out with the EUT in normal operation, which was shown in this test report and defined as:

Test Mode
Mode 1: Normal Operation Mode
Mode 2: IEEE 802.11a Link Mode
Mode 3: IEEE 802.11n 20MHz Link Mode
Mode 4: IEEE 802.11n 40MHz Link Mode
Mode 5: Receiver Mode

Software used to control the EUT for staying in continuous transmitting mode was programmed.

After verification, all tests were carried out with the worst case test modes as shown below except radiated spurious emission below 1GHz and power line conducted emissions below 30MHz, which worst case was in normal link mode only.

**IEEE 802.11a mode / 5180 ~ 5240MHz:**

Channel Low (5180MHz), Channel Mid (5220MHz) and Channel High (5240MHz) with 6Mbps data rate were chosen for full testing.

**IEEE 802.11a mode / 5260 ~ 5320MHz:**

Channel Low (5260MHz), Channel Mid (5280MHz) and Channel High (5320MHz) with 6Mbps data rate were chosen for full testing.

**IEEE 802.11a mode / 5500 ~ 5700MHz:**

Channel Low (5500MHz), Channel Mid (5580MHz) and Channel High (5700MHz) with 6Mbps data rate were chosen for full testing.

**IEEE 802.11n 20 MHz Channel mode / 5180 ~ 5240MHz:**

Channel Low (5180MHz), Channel Mid (5220MHz) and Channel High (5240MHz) with 6.5Mbps data rate were chosen for full testing.

**IEEE 802.11n 20 MHz Channel mode / 5260 ~ 5320MHz:**

Channel Low (5260MHz), Channel Mid (5280MHz) and Channel High (5320MHz) with 6.5Mbps data rate were chosen for full testing.

**IEEE 802.11n 20 MHz Channel mode / 5500 ~ 5700MHz:**

Channel Low (5500MHz), Channel Mid (5580MHz) and Channel High (5700MHz) with 6.5Mbps data rate were chosen for full testing.

**IEEE 802.11n 40 MHz Channel mode / 5190 ~ 5230MHz:**

Channel Low (5190MHz) and Channel High (5230MHz) with 6.5Mbps data rate were chosen for full testing.

**IEEE 802.11n 40 MHz Channel mode / 5270 ~ 5310MHz:**

Channel Low (5270MHz) and Channel High (5310MHz) with 6.5Mbps data rate were chosen for full testing.

**IEEE 802.11n 40 MHz Channel mode / 5510 ~ 5670MHz:**

Channel Low (5510MHz), Channel Mid (5590MHz) and Channel High (5670MHz) with 6.5Mbps data rate were chosen for full testing.



### 3.2. EUT Exercise Software

The EUT is operated in the engineering mode to fix the TX frequency for the purposes of measurement. According to its specifications, the EUT must comply with the requirements of Section 15.407 under the FCC Rules Part 15 Subpart E.

1.	Setup the EUT shown on 3.3.
2.	Turn on the power of all equipment.
3.	Turn on Wi-Fi function link to Notebook.
4.	EUT run test program.

### 3.3. Configuration of Test System Details

Conducted Emission

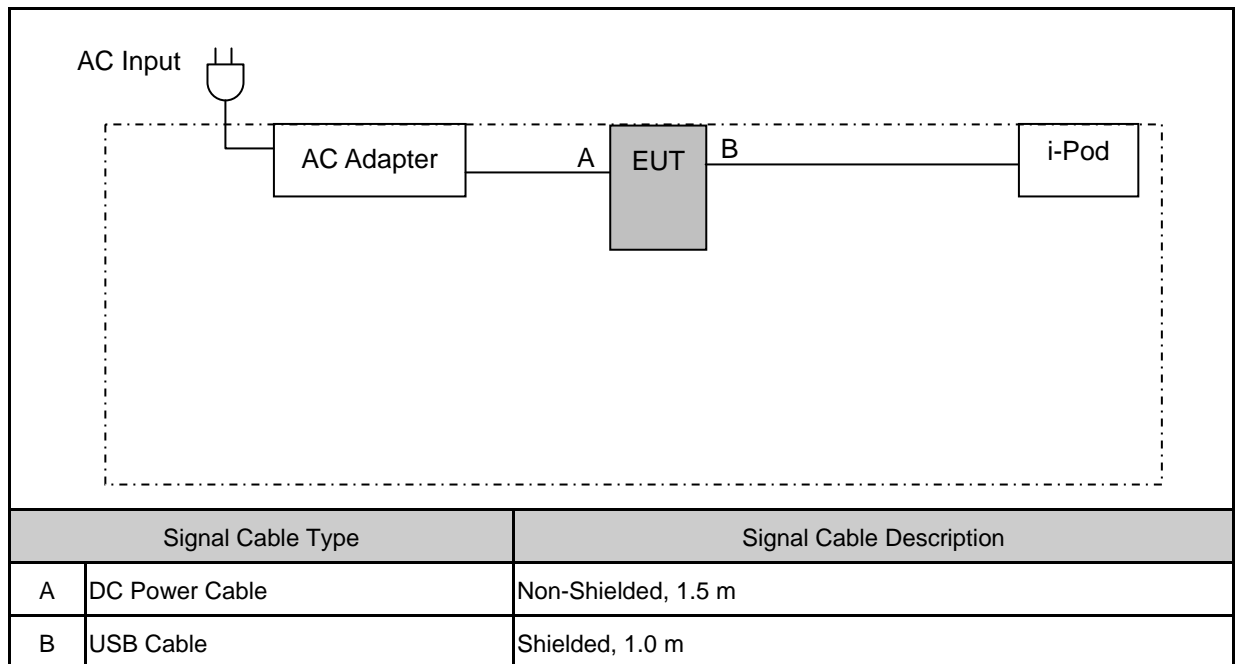

Radiated Emission below 1GHz

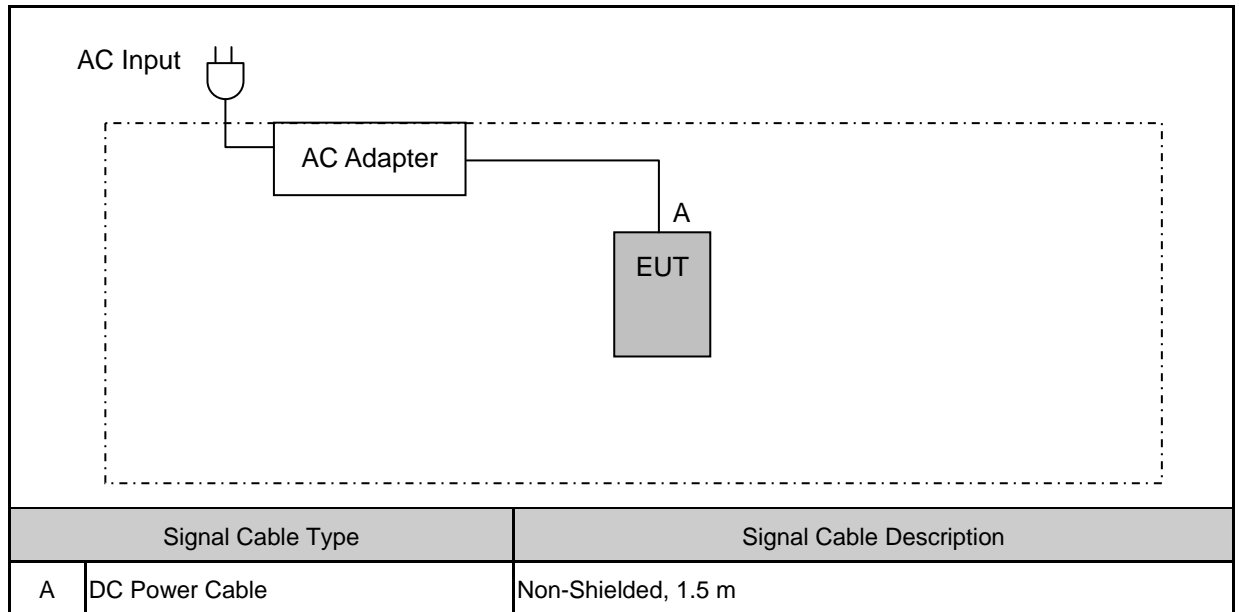

Radiated Emission above 1GHz

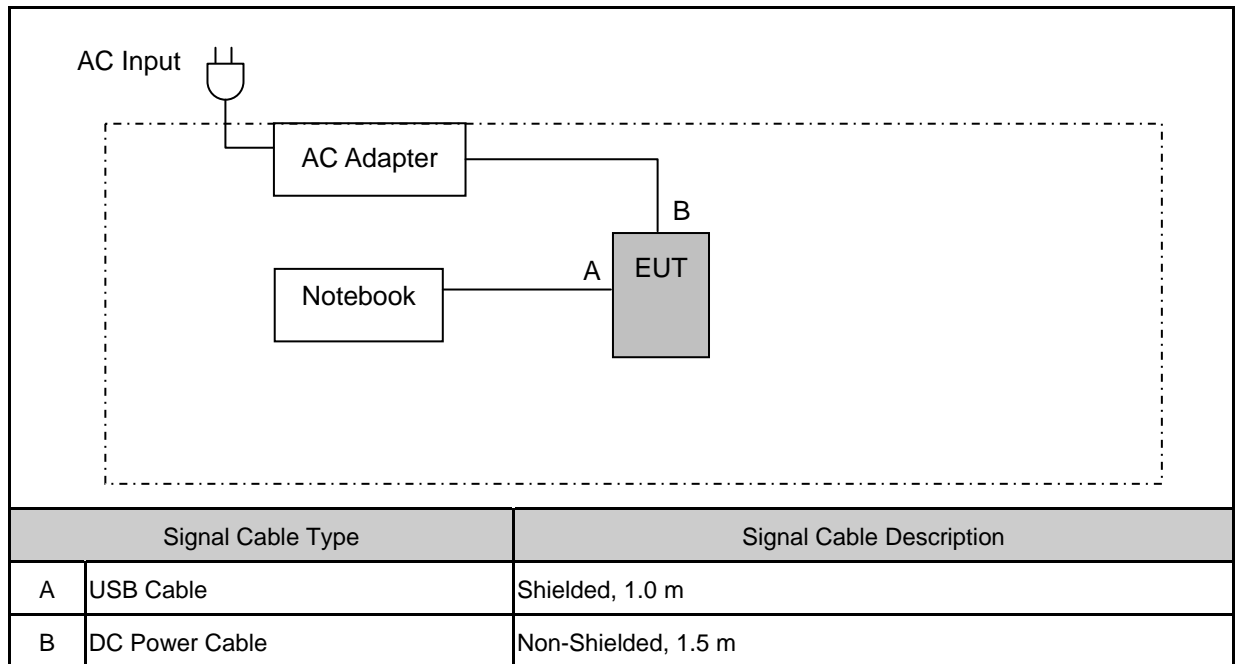

**3.4. Test Site Environment**

Items	Required (IEC 68-1)	Actual
Temperature (°C)	15-35	26
Humidity (%RH)	25-75	60
Barometric pressure (mbar)	860-1060	950

## 4 AC Power Conducted Emission Measurement

### 4.1. Limit

Frequency (MHz)	Quasi-peak	Average
0.15 - 0.5	66 to 56	56 to 46
0.50 - 5.0	56	46
5.0 - 30.0	60	50

### 4.2. Test Instruments

Describe	Manufacturer	Model Number	Serial Number	Cal. Date	Remark
Test Receiver	R&S	ESCI	100367	06/18/2012	(1)
LISN	R&S	ENV216	101040	03/04/2013	(1)
LISN	R&S	ENV216	101041	03/04/2013	(1)
Test Site	ATL	TE05	TE05	N.C.R.	-----

Remark: (1) Calibration period 1 year. (2) Calibration period 2 years.

NOTE: N.C.R. = No Calibration Request.

### 4.3. Test Setup

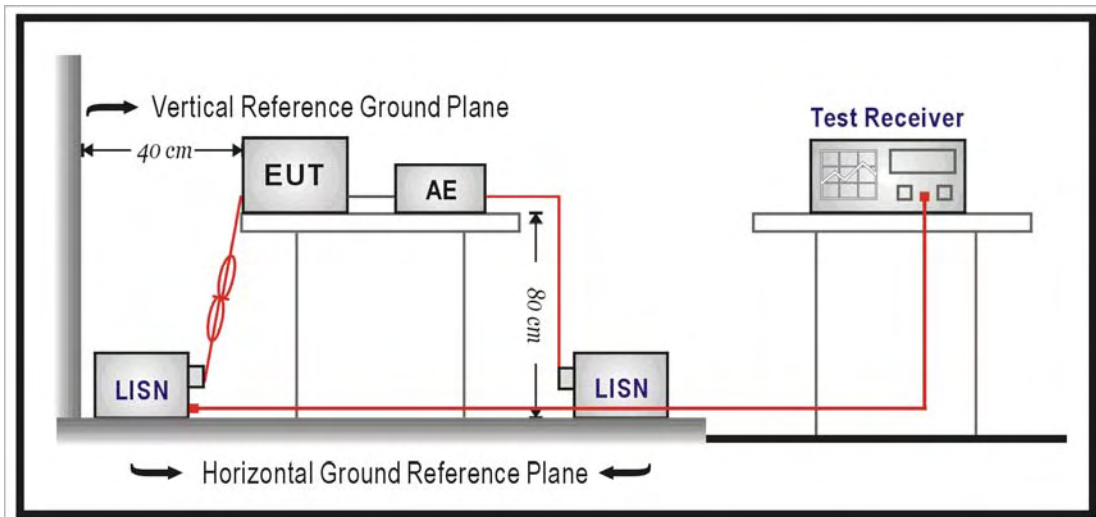

#### **4.4. Test Procedure**

The power line conducted emission measurements were performed in a shielded enclosure. The EUT was assembled on a wooden table which is 80 centimeters high, was placed 40 centimeters from the back wall and at least 1 meter from the sidewall.

Power was fed to the EUT from the public utility power grid through a line filter and EMCO Model 3162/2 SH Line Impedance Stabilization Networks (LISN). The LISN housing, measuring instrumentation case, ground plane, etc., were electrically bonded together at the same RF potential. The Spectrum analyzer was connected to the AC line through an isolation transformer. The 50-ohm output of the LISN was connected to the spectrum analyzer directly. Conducted emission levels were in the CISPR quasi-peak detection mode. The analyzer's 6 dB bandwidth was set to 9 KHz. No post-detector video filter was used.

The spectrum was scanned from 150 KHz to 30 MHz. The physical arrangement of the test system and associated cabling was varied (within the scope of arrangements likely to be encountered in actual use) to determine the effect on the unit's emanations in amplitude and frequency. All spurious emission frequencies were observed. The highest emission amplitudes relative to the appropriate limit were measured and have been recorded in paragraph 4.1.

#### 4.5. Test Result

Standard:	FCC Part 15E	Line:	L1
Test item:	Conducted Emission	Power:	AC 120V/60Hz
Model Number:	PS2 Speaker	Temp.(°C)/Hum.(%RH):	26(°C)/60%RH
Mode:	Mode 1	Date:	05/03/2013
		Test By:	Fly Lu
Description:			

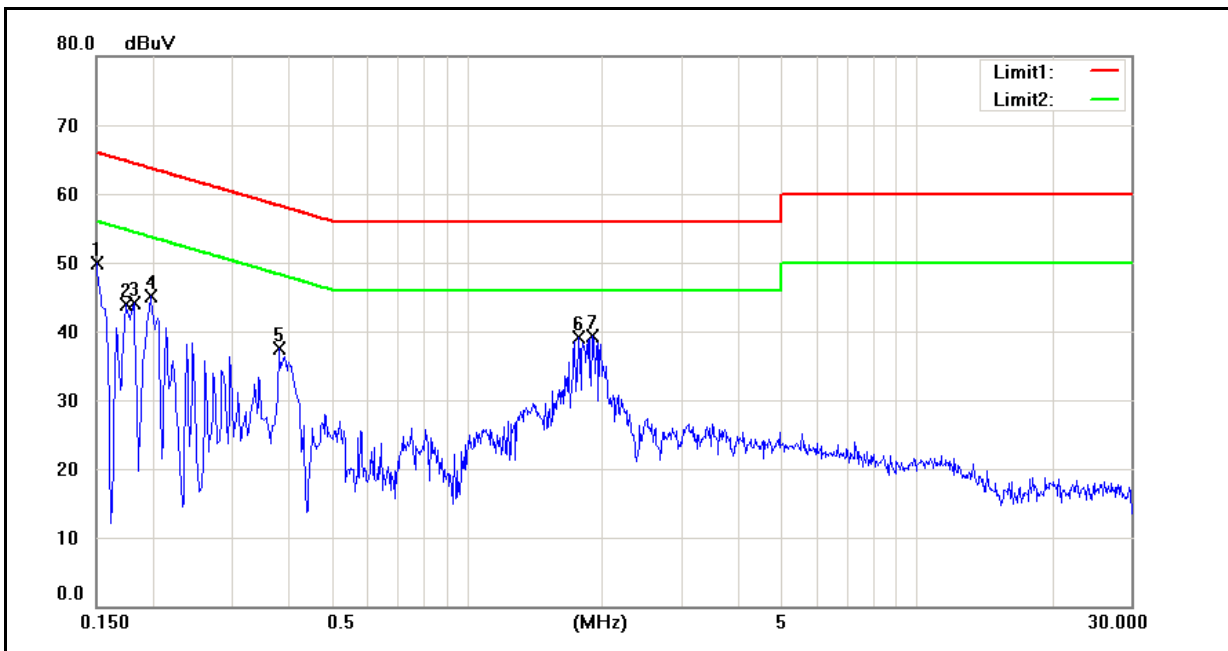

No.	Frequency (MHz)	QP reading (dBuV)	AVG reading (dBuV)	Correction factor (dB)	QP result (dBuV)	AVG result (dBuV)	QP limit (dBuV)	AVG limit (dBuV)	QP margin (dB)	AVG margin (dB)	Remark
1	0.1500	34.53	17.81	9.62	44.15	27.43	66.00	56.00	-21.85	-28.57	Pass
2	0.1740	31.37	16.65	9.62	40.99	26.27	64.77	54.77	-23.78	-28.50	Pass
3	0.1820	28.04	8.64	9.62	37.66	18.26	64.39	54.39	-26.73	-36.13	Pass
4	0.1980	28.72	15.18	9.62	38.34	24.80	63.69	53.69	-25.35	-28.89	Pass
5	0.3820	21.39	14.52	9.62	31.01	24.14	58.24	48.24	-27.23	-24.10	Pass
6	1.7740	20.37	14.81	9.69	30.06	24.50	56.00	46.00	-25.94	-21.50	Pass
7	1.8980	26.94	17.36	9.70	36.64	27.06	56.00	46.00	-19.36	-18.94	Pass

Standard:	FCC Part 15E	Line:	N
Test item:	Conducted Emission	Power:	AC 120V/60Hz
Model Number:	PS2 Speaker	Temp.(°C)/Hum.(%RH):	26(°C)/60%RH
Mode:	Mode 1	Date:	05/03/2013
		Test By:	Fly Lu
Description:			

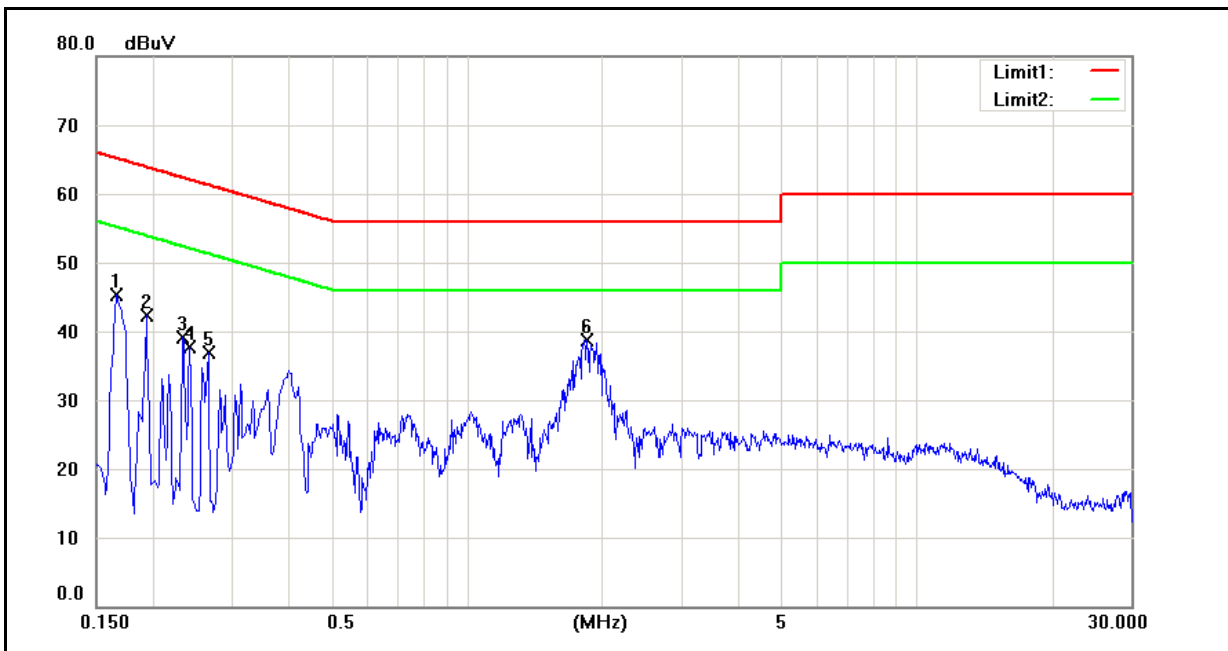

No.	Frequency (MHz)	QP reading (dBuV)	AVG reading (dBuV)	Correction factor (dB)	QP result (dBuV)	AVG result (dBuV)	QP limit (dBuV)	AVG limit (dBuV)	QP margin (dB)	AVG margin (dB)	Remark
1	0.1660	30.84	10.52	9.63	40.47	20.15	65.16	55.16	-24.69	-35.01	Pass
2	0.1940	27.73	9.84	9.63	37.36	19.47	63.86	53.86	-26.50	-34.39	Pass
3	0.2340	21.21	2.27	9.63	30.84	11.90	62.31	52.31	-31.47	-40.41	Pass
4	0.2420	21.26	3.96	9.63	30.89	13.59	62.03	52.03	-31.14	-38.44	Pass
5	0.2660	19.01	2.28	9.63	28.64	11.91	61.24	51.24	-32.60	-39.33	Pass
6	1.8500	27.12	15.76	9.69	36.81	25.45	56.00	46.00	-19.19	-20.55	Pass

## 5 Radiated Emission Measurement

### 5.1. Limit

#### Limits of Radiated Emission Measurement

Emissions radiated outside of the specified bands, shall be according to the general radiated limits in 15.209 as following:

Frequency Range (MHz)	Field Strength (microvolts/meter)	Measurement Distance (meters)
0.009 ~ 0.490	2400/F(kHz)	300
0.490 ~ 1.705	24000/F(kHz)	30
1.705 ~ 30.0	30	30
30 ~ 88	10	3
88 ~ 216	150	3
216 ~ 960	200	3
Above 960	500	3

Note:

1. The lower limit shall apply at the transition frequencies.
2. Emission level (dBuV/m) = 20 log Emission level (uV/m).
3. As shown in 15.35(b), for frequencies above 1000MHz, the field strength limits are based on average detector, however, the peak field strength of any emission shall not exceed the maximum permitted average limits, specified above by more than 20dB under any condition of modulation.

### 5.2. Test Instruments

3 Meter Chamber					
Equipment	Manufacturer	Model Number	Serial Number	Cal. Date	Remark
RF Pre-selector	Agilent	N9039A	MY46520256	01/21/2013	(1)
Spectrum Analyzer	Agilent	E4446A	MY46180578	01/21/2013	(1)
Pre Amplifier	Agilent	8449B	3008A02237	02/21/2013	(1)
Pre Amplifier	Agilent	8447D	2944A10961	02/21/2013	(1)
Broadband Antenna (30MHz~1GHz)	SCHWARZBECK MESS-ELEKTRONIK	VULB9163	9163-270	06/29/2012	(1)
Horn Antenna (1~18GHz)	SCHWARZBECK MESS-ELEKTRONIK	BBHA9120D	9120D-550	06/15/2012	(1)
Horn Antenna (18~40GHz)	SCHWARZBECK MESS-ELEKTRONIK	BBHA9170	9170-320	06/21/2012	(1)
Test Site	ATL	TE01	888001	08/28/2012	(1)

Remark: (1) Calibration period 1 year. (2) Calibration period 2 years.

NOTE: N.C.R. = No Calibration Request.



### 5.3. Setup

9kHz ~ 30MHz

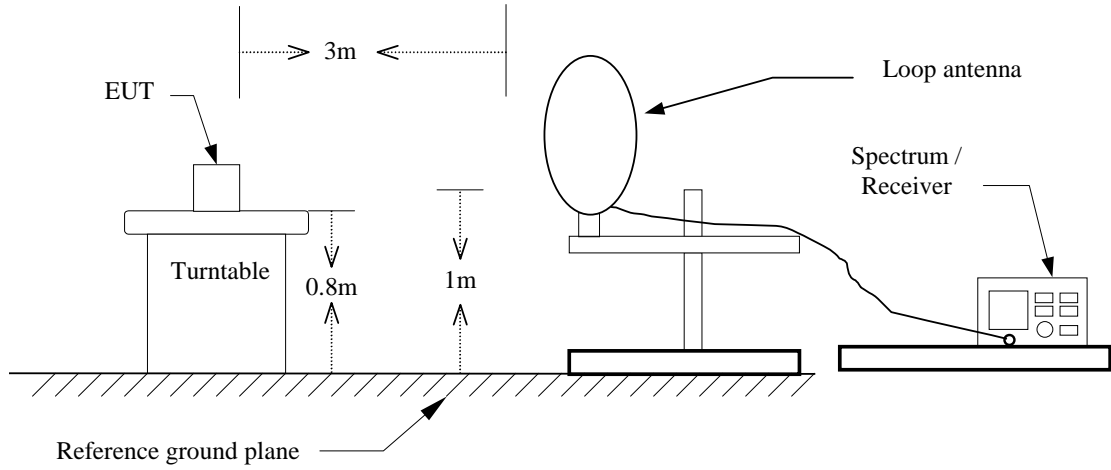

30MHz ~ 1GHz

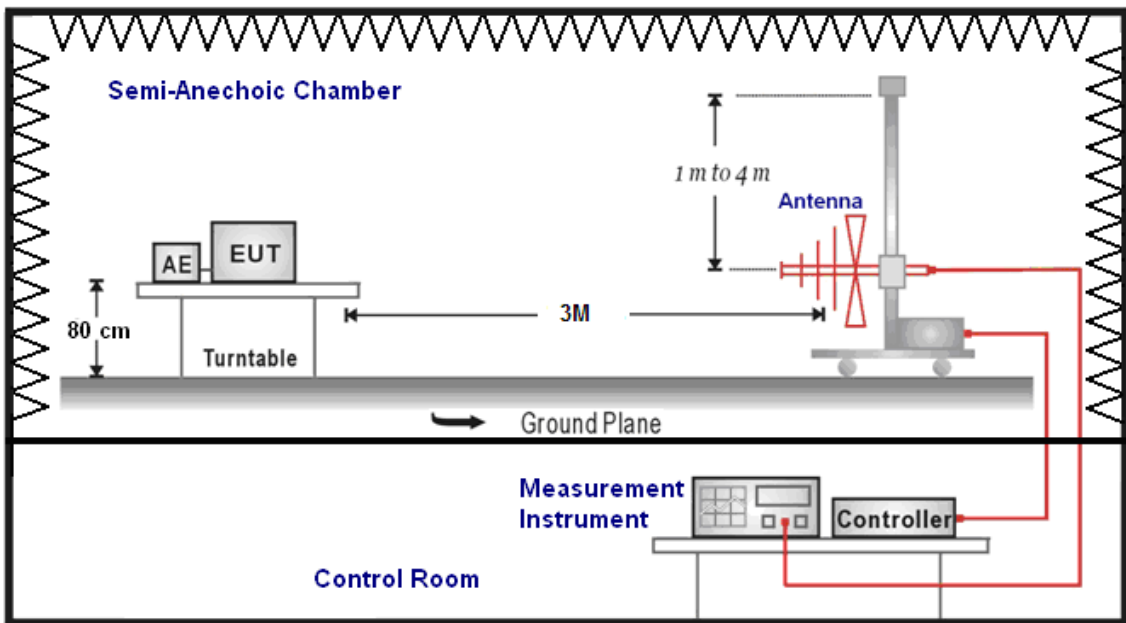

Above 1GHz

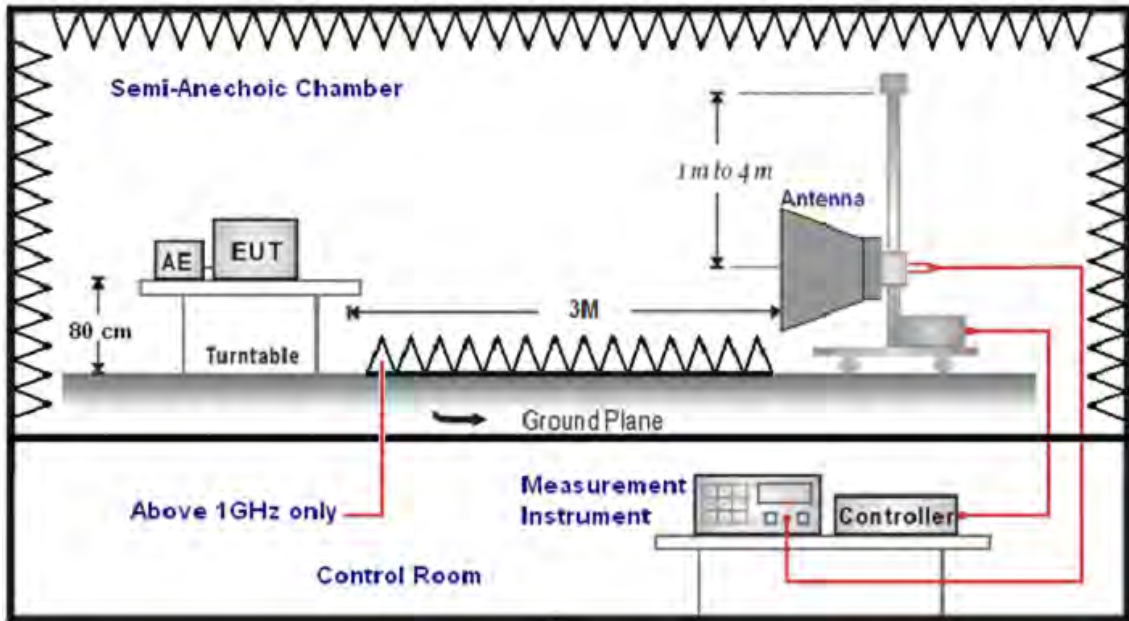

## 5.4. Test Procedure

Final radiation measurements were made on a three-meter, Semi Anechoic Chamber. The EUT system was placed on a nonconductive turntable which is 0.8 meters height, top surface 1.0 x 1.5 meter. The spectrum was examined from 250 MHz to 2.5 GHz in order to cover the whole spectrum below 10th harmonic which could generate from the EUT. During the test, EUT was set to transmit continuously & Measurements spectrum range from 9 kHz to 40 GHz is investigated.

For measurements below 1 GHz the resolution bandwidth is set to 100 kHz for peak detection measurements or 120 kHz for quasi-peak detection measurements. Peak detection is used unless otherwise noted as quasi-peak.

For measurements above 1 GHz the resolution bandwidth is set to 1 MHz, and then the video bandwidth is set to 3 MHz for peak measurements and 3 MHz for average measurements.

A nonconductive material surrounded the EUT to supporting the EUT for standing on three orthogonal planes. At each condition, the EUT was rotated 360 degrees, and the antenna was raised and lowered from one to four meters to find the maximum emission levels. Measurements were taken using both horizontal and vertical antenna polarization.

SCHWARZBECK MESS-ELEKTRONIK Trilog-Broadband Antenna (mode SB AC VULB) at 3 Meter and the ETS-Lindgren Double-Ridged Waveguide Horn antenna (model 3117) Schwarzbeck Mess-Elektronik Broadband Horn Antenna (BBHA 9170) was used in frequencies 1 – 40 GHz at a distance of 1 meter. All test results were extrapolated to equivalent signal at 3 meters utilizing an inverse linear distance extrapolation Factor (20dB/decade).

For testing above 1GHz, the emission level of the EUT in peak mode was 20dB lower than average limit (that means the emission level in peak mode also complies with the limit in average mode), then testing will be stopped and peak values of EUT will be reported, otherwise, the emissions will be measured in average mode again and reported.

Appropriate preamplifiers were used for improving sensitivity and precautions were taken to avoid overloading or desensitizing the spectrum analyzer. No post – detector video filters were used in the test.

The spectrum analyzer's 6 dB bandwidth was set to 1 MHz, and the analyzer was operated in the peak detection mode, for frequencies both below and up 1 GHz. The average levels were obtained by subtracting the duty cycle correction factor from the peak readings.

The following procedures were used to convert the emission levels measured in decibels referenced to 1 microvolt (dBuV) into field intensity in micro volts per meter (uV/m).

The actual field intensity in decibels referenced to 1 microvolt in to field intensity in micro volts per meter (dBuV/m).

The actual field intensity in referenced to 1 microvolt per meter (dBuV/m) is determined by algebraically adding the measured reading in dBuV, the antenna factor (dB), and cable loss (dB) and Subtracting the gain of preamplifier (dB) is auto calculate in spectrum analyzer.

(1) Amplitude (dBuV/m) = FI (dBuV) +AF (dBuV) +CL (dBuV)-Gain (dB)

FI= Reading of the field intensity.

AF= Antenna factor.

CL= Cable loss.

P.S Amplitude is auto calculate in spectrum analyzer.

(2) Actual Amplitude (dBuV/m) = Amplitude (dBuV)-Dis(dB)

The FCC specified emission limits were calculated according the EUT operating frequency and by following linear interpolation equations:

(a) For fundamental frequency : Transmitter Output < +30dBm

(b) For spurious frequency : Spurious emission limits = fundamental emission limit /10

## 5.5. Test Result

### Below 1GHz

Standard:	FCC Part 15E	Test Distance:	3m
Test item:	Radiated Emission	Power:	AC 120V/60Hz
Model Number:	PS2 Speaker	Temp.(°C)/Hum.(%RH):	26(°C)/60%RH
Mode:	Mode 1	Date:	05/03/2013
Ant.Polar.:	Horizontal	Test By:	Fly Lu

No.	Frequency (MHz)	Reading (dBuV)	Correct Factor(dB/m)	Result (dBuV/m)	Limit (dBuV/m)	Margin (dB)	Remark
1	120.0000	45.42	-16.06	29.36	43.50	-14.14	QP
2	204.0000	43.77	-13.97	29.80	43.50	-13.70	QP
3	398.5000	43.01	-8.61	34.40	46.00	-11.60	QP
4	529.5000	28.63	-6.64	21.99	46.00	-24.01	QP
5	750.0000	31.64	-2.46	29.18	46.00	-16.82	QP
6	919.5000	25.35	0.72	26.07	46.00	-19.93	QP

Standard:	FCC Part 15E	Test Distance:	3m
Test item:	Radiated Emission	Power:	AC 120V/60Hz
Model Number:	PS2 Speaker	Temp.(°C)/Hum.(%RH):	26(°C)/60%RH
Mode:	Mode 1	Date:	05/03/2013
Ant.Polar.:	Vertical	Test By:	Fly Lu

No.	Frequency (MHz)	Reading (dBuV)	Correct Factor(dB/m)	Result (dBuV/m)	Limit (dBuV/m)	Margin (dB)	Remark
1	120.0000	42.54	-16.06	26.48	43.50	-17.02	QP
2	201.0000	40.45	-13.90	26.55	43.50	-16.95	QP
3	360.0000	41.85	-8.73	33.12	46.00	-12.88	QP
4	501.0000	39.15	-6.79	32.36	46.00	-13.64	QP
5	673.0000	30.26	-3.90	26.36	46.00	-19.64	QP
6	798.5000	32.27	-1.57	30.70	46.00	-15.30	QP

Note: No emission found between lowest internal used/generated frequency to 30MHz (9kHz~30MHz).

**Above 1GHz**

Standard:	FCC Part 15E			Test Distance:	3m		
Test item:	Radiated Emission			Power:	AC 120V/60Hz		
Model Number:	PS2 Speaker			Temp.(°C)/Hum.(%RH):	26(°C)/60%RH		
Mode:	Mode 2			Date:	05/02/2013		
Frequency:	5180MHz			Test By:	Fly Lu		
Frequency (MHz)	Reading (dBuV)	Correct Factor(dB/m)	Result (dBuV/m)	Limit (dBuV/m)	Margin (dB)	Remark	Ant.Polar. H / V
2799.000	33.66	5.40	39.06	74.00	-34.94	peak	H
4647.000	30.68	11.25	41.93	74.00	-32.07	peak	H
7503.000	27.76	20.81	48.57	74.00	-25.43	peak	H
2722.000	33.26	5.19	38.45	74.00	-35.55	peak	V
4703.000	29.37	11.40	40.77	74.00	-33.23	peak	V
7517.000	27.87	20.82	48.69	74.00	-25.31	peak	V

Standard:	FCC Part 15E			Test Distance:	3m		
Test item:	Radiated Emission			Power:	AC 120V/60Hz		
Model Number:	PS2 Speaker			Temp.(°C)/Hum.(%RH):	26(°C)/60%RH		
Mode:	Mode 2			Date:	05/02/2013		
Frequency:	5220MHz			Test By:	Fly Lu		
Frequency (MHz)	Reading (dBuV)	Correct Factor(dB/m)	Result (dBuV/m)	Limit (dBuV/m)	Margin (dB)	Remark	Ant.Polar. H / V
2757.000	30.36	5.28	35.64	74.00	-38.36	peak	H
4605.000	29.92	11.15	41.07	74.00	-32.93	peak	H
7559.000	26.10	20.84	46.94	74.00	-27.06	peak	H
2778.000	33.71	5.34	39.05	74.00	-34.95	peak	V
4689.000	29.87	11.37	41.24	74.00	-32.76	peak	V
7377.000	27.17	20.57	47.74	74.00	-26.26	peak	V

Standard:	FCC Part 15E			Test Distance:	3m		
Test item:	Radiated Emission			Power:	AC 120V/60Hz		
Model Number:	PS2 Speaker			Temp.(°C)/Hum.(%RH):	26(°C)/60%RH		
Mode:	Mode 2			Date:	05/02/2013		
Frequency:	5240MHz			Test By:	Fly Lu		
Frequency (MHz)	Reading (dBuV)	Correct Factor(dB/m)	Result (dBuV/m)	Limit (dBuV/m)	Margin (dB)	Remark	Ant.Polar. H / V
2757.000	32.51	5.28	37.79	74.00	-36.21	peak	H
4661.000	31.38	11.29	42.67	74.00	-31.33	peak	H
7454.000	28.16	20.73	48.89	74.00	-25.11	peak	H
2785.000	32.31	5.36	37.67	74.00	-36.33	peak	V
4647.000	30.77	11.25	42.02	74.00	-31.98	peak	V
7433.000	27.08	20.69	47.77	74.00	-26.23	peak	V

Standard:	FCC Part 15E			Test Distance:	3m		
Test item:	Radiated Emission			Power:	AC 120V/60Hz		
Model Number:	PS2 Speaker			Temp.(°C)/Hum.(%RH):	26(°C)/60%RH		
Mode:	Mode 2			Date:	05/02/2013		
Frequency:	5260MHz			Test By:	Fly Lu		
Frequency (MHz)	Reading (dBuV)	Correct Factor(dB/m)	Result (dBuV/m)	Limit (dBuV/m)	Margin (dB)	Remark	Ant.Polar. H / V
2743.000	32.58	5.25	37.83	74.00	-36.17	peak	H
4591.000	31.18	11.11	42.29	74.00	-31.71	peak	H
7370.000	27.30	20.57	47.87	74.00	-26.13	peak	H
2792.000	32.82	5.38	38.20	74.00	-35.80	peak	V
4654.000	30.92	11.27	42.19	74.00	-31.81	peak	V
7475.000	27.74	20.76	48.50	74.00	-25.50	peak	V

Standard:	FCC Part 15E			Test Distance:	3m		
Test item:	Radiated Emission			Power:	AC 120V/60Hz		
Model Number:	PS2 Speaker			Temp.(°C)/Hum.(%RH):	26(°C)/60%RH		
Mode:	Mode 2			Date:	05/02/2013		
Frequency:	5280MHz			Test By:	Fly Lu		
Frequency (MHz)	Reading (dBuV)	Correct Factor(dB/m)	Result (dBuV/m)	Limit (dBuV/m)	Margin (dB)	Remark	Ant.Polar. H / V
2785.000	32.55	5.36	37.91	74.00	-36.09	peak	H
4696.000	30.38	11.38	41.76	74.00	-32.24	peak	H
7454.000	28.15	20.73	48.88	74.00	-25.12	peak	H
2743.000	32.73	5.25	37.98	74.00	-36.02	peak	V
4647.000	30.11	11.25	41.36	74.00	-32.64	peak	V
7433.000	28.02	20.69	48.71	74.00	-25.29	peak	V

Standard:	FCC Part 15E			Test Distance:	3m		
Test item:	Radiated Emission			Power:	AC 120V/60Hz		
Model Number:	PS2 Speaker			Temp.(°C)/Hum.(%RH):	26(°C)/60%RH		
Mode:	Mode 2			Date:	05/02/2013		
Frequency:	5320MHz			Test By:	Fly Lu		
Frequency (MHz)	Reading (dBuV)	Correct Factor(dB/m)	Result (dBuV/m)	Limit (dBuV/m)	Margin (dB)	Remark	Ant.Polar. H / V
2806.000	33.13	5.41	38.54	74.00	-35.46	peak	H
4626.000	30.22	11.20	41.42	74.00	-32.58	peak	H
7517.000	26.95	20.82	47.77	74.00	-26.23	peak	H
2841.000	31.70	5.49	37.19	74.00	-36.81	peak	V
4703.000	30.51	11.40	41.91	74.00	-32.09	peak	V
7510.000	26.61	20.82	47.43	74.00	-26.57	peak	V



Standard:	FCC Part 15E			Test Distance:	3m		
Test item:	Radiated Emission			Power:	AC 120V/60Hz		
Model Number:	PS2 Speaker			Temp.(°C)/Hum.(%RH):	26(°C)/60%RH		
Mode:	Mode 2			Date:	05/02/2013		
Frequency:	5500MHz			Test By:	Fly Lu		
Frequency (MHz)	Reading (dBuV)	Correct Factor(dB/m)	Result (dBuV/m)	Limit (dBuV/m)	Margin (dB)	Remark	Ant.Polar. H / V
2771.000	33.91	5.32	39.23	74.00	-34.77	peak	H
4696.000	31.23	11.38	42.61	74.00	-31.39	peak	H
7447.000	28.97	20.71	49.68	74.00	-24.32	peak	H
2743.000	32.01	5.25	37.26	74.00	-36.74	peak	V
4654.000	29.01	11.27	40.28	74.00	-33.72	peak	V
7489.000	29.19	20.79	49.98	74.00	-24.02	peak	V

Standard:	FCC Part 15E			Test Distance:	3m		
Test item:	Radiated Emission			Power:	AC 120V/60Hz		
Model Number:	PS2 Speaker			Temp.(°C)/Hum.(%RH):	26(°C)/60%RH		
Mode:	Mode 2			Date:	05/02/2013		
Frequency:	5580MHz			Test By:	Fly Lu		
Frequency (MHz)	Reading (dBuV)	Correct Factor(dB/m)	Result (dBuV/m)	Limit (dBuV/m)	Margin (dB)	Remark	Ant.Polar. H / V
2729.000	32.99	5.21	38.20	74.00	-35.80	peak	H
4675.000	30.24	11.33	41.57	74.00	-32.43	peak	H
7475.000	28.87	20.76	49.63	74.00	-24.37	peak	H
2757.000	32.65	5.28	37.93	74.00	-36.07	peak	V
4661.000	30.97	11.29	42.26	74.00	-31.74	peak	V
7398.000	28.00	20.63	48.63	74.00	-25.37	peak	V

Standard:	FCC Part 15E			Test Distance:	3m		
Test item:	Radiated Emission			Power:	AC 120V/60Hz		
Model Number:	PS2 Speaker			Temp.(°C)/Hum.(%RH):	26(°C)/60%RH		
Mode:	Mode 2			Date:	05/02/2013		
Frequency:	5700MHz			Test By:	Fly Lu		
Frequency (MHz)	Reading (dBuV)	Correct Factor(dB/m)	Result (dBuV/m)	Limit (dBuV/m)	Margin (dB)	Remark	Ant.Polar. H / V
2757.000	32.86	5.28	38.14	74.00	-35.86	peak	H
4661.000	30.38	11.29	41.67	74.00	-32.33	peak	H
7433.000	27.60	20.69	48.29	74.00	-25.71	peak	H
2750.000	31.98	5.27	37.25	74.00	-36.75	peak	V
4759.000	30.45	11.54	41.99	74.00	-32.01	peak	V
7447.000	28.41	20.71	49.12	74.00	-24.88	peak	V

Standard:	FCC Part 15E			Test Distance:	3m		
Test item:	Radiated Emission			Power:	AC 120V/60Hz		
Model Number:	PS2 Speaker			Temp.(°C)/Hum.(%RH):	26(°C)/60%RH		
Mode:	Mode 3			Date:	05/02/2013		
Frequency:	5180MHz			Test By:	Fly Lu		
Frequency (MHz)	Reading (dBuV)	Correct Factor(dB/m)	Result (dBuV/m)	Limit (dBuV/m)	Margin (dB)	Remark	Ant.Polar. H / V
2729.000	33.46	5.21	38.67	74.00	-35.33	peak	H
4717.000	31.53	11.43	42.96	74.00	-31.04	peak	H
7405.000	29.19	20.63	49.82	74.00	-24.18	peak	H
2722.000	33.34	5.19	38.53	74.00	-35.47	peak	V
4682.000	30.80	11.34	42.14	74.00	-31.86	peak	V
7391.000	27.78	20.61	48.39	74.00	-25.61	peak	V

Standard:	FCC Part 15E			Test Distance:	3m		
Test item:	Radiated Emission			Power:	AC 120V/60Hz		
Model Number:	PS2 Speaker			Temp.(°C)/Hum.(%RH):	26(°C)/60%RH		
Mode:	Mode 3			Date:	05/02/2013		
Frequency:	5220MHz			Test By:	Fly Lu		
Frequency (MHz)	Reading (dBuV)	Correct Factor(dB/m)	Result (dBuV/m)	Limit (dBuV/m)	Margin (dB)	Remark	Ant.Polar. H / V
2778.000	32.48	5.34	37.82	74.00	-36.18	peak	H
4647.000	30.58	11.25	41.83	74.00	-32.17	peak	H
7510.000	28.54	20.82	49.36	74.00	-24.64	peak	H
2806.000	35.06	5.41	40.47	74.00	-33.53	peak	V
4605.000	30.73	11.15	41.88	74.00	-32.12	peak	V
7419.000	28.71	20.66	49.37	74.00	-24.63	peak	V

Standard:	FCC Part 15E			Test Distance:	3m		
Test item:	Radiated Emission			Power:	AC 120V/60Hz		
Model Number:	PS2 Speaker			Temp.(°C)/Hum.(%RH):	26(°C)/60%RH		
Mode:	Mode 3			Date:	05/02/2013		
Frequency:	5240MHz			Test By:	Fly Lu		
Frequency (MHz)	Reading (dBuV)	Correct Factor(dB/m)	Result (dBuV/m)	Limit (dBuV/m)	Margin (dB)	Remark	Ant.Polar. H / V
2806.000	33.14	5.41	38.55	74.00	-35.45	peak	H
4591.000	31.18	11.11	42.29	74.00	-31.71	peak	H
7461.000	28.13	20.73	48.86	74.00	-25.14	peak	H
2806.000	33.14	5.41	38.55	74.00	-35.45	peak	V
4591.000	31.18	11.11	42.29	74.00	-31.71	peak	V
7461.000	28.13	20.73	48.86	74.00	-25.14	peak	V

Standard:	FCC Part 15E			Test Distance:	3m		
Test item:	Radiated Emission			Power:	AC 120V/60Hz		
Model Number:	PS2 Speaker			Temp.(°C)/Hum.(%RH):	26(°C)/60%RH		
Mode:	Mode 3			Date:	05/02/2013		
Frequency:	5260MHz			Test By:	Fly Lu		
Frequency (MHz)	Reading (dBuV)	Correct Factor(dB/m)	Result (dBuV/m)	Limit (dBuV/m)	Margin (dB)	Remark	Ant.Polar. H / V
2771.000	33.78	5.32	39.10	74.00	-34.90	peak	H
4675.000	31.46	11.33	42.79	74.00	-31.21	peak	H
7454.000	29.97	20.73	50.70	74.00	-23.30	peak	H
2771.000	34.63	5.32	39.95	74.00	-34.05	peak	V
4766.000	31.16	11.56	42.72	74.00	-31.28	peak	V
7482.000	28.54	20.78	49.32	74.00	-24.68	peak	V

Standard:	FCC Part 15E			Test Distance:	3m		
Test item:	Radiated Emission			Power:	AC 120V/60Hz		
Model Number:	PS2 Speaker			Temp.(°C)/Hum.(%RH):	26(°C)/60%RH		
Mode:	Mode 3			Date:	05/02/2013		
Frequency:	5280MHz			Test By:	Fly Lu		
Frequency (MHz)	Reading (dBuV)	Correct Factor(dB/m)	Result (dBuV/m)	Limit (dBuV/m)	Margin (dB)	Remark	Ant.Polar. H / V
2729.000	34.80	5.21	40.01	74.00	-33.99	peak	H
4591.000	30.96	11.11	42.07	74.00	-31.93	peak	H
7454.000	28.75	20.73	49.48	74.00	-24.52	peak	H
2869.000	32.90	5.57	38.47	74.00	-35.53	peak	V
4675.000	31.10	11.33	42.43	74.00	-31.57	peak	V
7503.000	28.10	20.81	48.91	74.00	-25.09	peak	V

Standard:	FCC Part 15E			Test Distance:	3m		
Test item:	Radiated Emission			Power:	AC 120V/60Hz		
Model Number:	PS2 Speaker			Temp.(°C)/Hum.(%RH):	26(°C)/60%RH		
Mode:	Mode 3			Date:	05/02/2013		
Frequency:	5320MHz			Test By:	Fly Lu		
Frequency (MHz)	Reading (dBuV)	Correct Factor(dB/m)	Result (dBuV/m)	Limit (dBuV/m)	Margin (dB)	Remark	Ant.Polar. H / V
2729.000	32.99	5.21	38.20	74.00	-35.80	peak	H
4654.000	30.75	11.27	42.02	74.00	-31.98	peak	H
7377.000	28.07	20.57	48.64	74.00	-25.36	peak	H
2771.000	33.63	5.32	38.95	74.00	-35.05	peak	V
4633.000	30.95	11.22	42.17	74.00	-31.83	peak	V
7405.000	28.29	20.63	48.92	74.00	-25.08	peak	V

Standard:	FCC Part 15E			Test Distance:	3m		
Test item:	Radiated Emission			Power:	AC 120V/60Hz		
Model Number:	PS2 Speaker			Temp.(°C)/Hum.(%RH):	26(°C)/60%RH		
Mode:	Mode 3			Date:	05/02/2013		
Frequency:	5500MHz			Test By:	Fly Lu		
Frequency (MHz)	Reading (dBuV)	Correct Factor(dB/m)	Result (dBuV/m)	Limit (dBuV/m)	Margin (dB)	Remark	Ant.Polar. H / V
2785.000	32.64	5.36	38.00	74.00	-36.00	peak	H
4661.000	29.89	11.29	41.18	74.00	-32.82	peak	H
7419.000	27.91	20.66	48.57	74.00	-25.43	peak	H
2750.000	33.21	5.27	38.48	74.00	-35.52	peak	V
4703.000	30.93	11.40	42.33	74.00	-31.67	peak	V
7426.000	28.49	20.67	49.16	74.00	-24.84	peak	V

Standard:	FCC Part 15E			Test Distance:	3m		
Test item:	Radiated Emission			Power:	AC 120V/60Hz		
Model Number:	PS2 Speaker			Temp.(°C)/Hum.(%RH):	26(°C)/60%RH		
Mode:	Mode 3			Date:	05/02/2013		
Frequency:	5580MHz			Test By:	Fly Lu		
Frequency (MHz)	Reading (dBuV)	Correct Factor(dB/m)	Result (dBuV/m)	Limit (dBuV/m)	Margin (dB)	Remark	Ant.Polar. H / V
2799.000	32.67	5.40	38.07	74.00	-35.93	peak	H
4577.000	29.86	11.07	40.93	74.00	-33.07	peak	H
7405.000	27.93	20.63	48.56	74.00	-25.44	peak	H
2785.000	34.00	5.36	39.36	74.00	-34.64	peak	V
4668.000	31.02	11.32	42.34	74.00	-31.66	peak	V
7433.000	29.43	20.69	50.12	74.00	-23.88	peak	V

Standard:	FCC Part 15E			Test Distance:	3m		
Test item:	Radiated Emission			Power:	AC 120V/60Hz		
Model Number:	PS2 Speaker			Temp.(°C)/Hum.(%RH):	26(°C)/60%RH		
Mode:	Mode 3			Date:	05/02/2013		
Frequency:	5700MHz			Test By:	Fly Lu		
Frequency (MHz)	Reading (dBuV)	Correct Factor(dB/m)	Result (dBuV/m)	Limit (dBuV/m)	Margin (dB)	Remark	Ant.Polar. H / V
2771.000	32.07	5.32	37.39	74.00	-36.61	peak	H
4752.000	30.40	11.52	41.92	74.00	-32.08	peak	H
7412.000	28.51	20.64	49.15	74.00	-24.85	peak	H
2827.000	33.09	5.46	38.55	74.00	-35.45	peak	V
4717.000	30.06	11.43	41.49	74.00	-32.51	peak	V
7454.000	29.62	20.73	50.35	74.00	-23.65	peak	V

Standard:	FCC Part 15E			Test Distance:	3m		
Test item:	Radiated Emission			Power:	AC 120V/60Hz		
Model Number:	PS2 Speaker			Temp.(°C)/Hum.(%RH):	26(°C)/60%RH		
Mode:	Mode 4			Date:	05/02/2013		
Frequency:	5190MHz			Test By:	Fly Lu		
Frequency (MHz)	Reading (dBuV)	Correct Factor(dB/m)	Result (dBuV/m)	Limit (dBuV/m)	Margin (dB)	Remark	Ant.Polar. H / V
2701.000	30.98	5.13	36.11	74.00	-37.89	peak	H
4703.000	28.39	11.40	39.79	74.00	-34.21	peak	H
7559.000	29.32	20.84	50.16	74.00	-23.84	peak	H
2778.000	32.33	5.34	37.67	74.00	-36.33	peak	V
4675.000	31.27	11.33	42.60	74.00	-31.40	peak	V
7559.000	27.69	20.84	48.53	74.00	-25.47	peak	V

Standard:	FCC Part 15E			Test Distance:	3m		
Test item:	Radiated Emission			Power:	AC 120V/60Hz		
Model Number:	PS2 Speaker			Temp.(°C)/Hum.(%RH):	26(°C)/60%RH		
Mode:	Mode 4			Date:	05/02/2013		
Frequency:	5210MHz			Test By:	Fly Lu		
Frequency (MHz)	Reading (dBuV)	Correct Factor(dB/m)	Result (dBuV/m)	Limit (dBuV/m)	Margin (dB)	Remark	Ant.Polar. H / V
2778.000	32.29	5.34	37.63	74.00	-36.37	peak	H
4710.000	30.44	11.41	41.85	74.00	-32.15	peak	H
7370.000	28.27	20.57	48.84	74.00	-25.16	peak	H
2645.000	32.74	4.99	37.73	68.20	-30.47	peak	V
4605.000	31.49	11.15	42.64	74.00	-31.36	peak	V
7489.000	29.64	20.79	50.43	74.00	-23.57	peak	V

Standard:	FCC Part 15E			Test Distance:	3m		
Test item:	Radiated Emission			Power:	AC 120V/60Hz		
Model Number:	PS2 Speaker			Temp.(°C)/Hum.(%RH):	26(°C)/60%RH		
Mode:	Mode 4			Date:	05/02/2013		
Frequency:	5230MHz			Test By:	Fly Lu		
Frequency (MHz)	Reading (dBuV)	Correct Factor(dB/m)	Result (dBuV/m)	Limit (dBuV/m)	Margin (dB)	Remark	Ant.Polar. H / V
2827.000	32.31	5.46	37.77	74.00	-36.23	peak	H
4738.000	30.29	11.50	41.79	74.00	-32.21	peak	H
7370.000	28.83	20.57	49.40	74.00	-24.60	peak	H
2743.000	32.44	5.25	37.69	74.00	-36.31	peak	V
4675.000	31.66	11.33	42.99	74.00	-31.01	peak	V
7454.000	28.76	20.73	49.49	74.00	-24.51	peak	V

Standard:	FCC Part 15E			Test Distance:	3m		
Test item:	Radiated Emission			Power:	AC 120V/60Hz		
Model Number:	PS2 Speaker			Temp.(°C)/Hum.(%RH):	26(°C)/60%RH		
Mode:	Mode 4			Date:	05/02/2013		
Frequency:	5270MHz			Test By:	Fly Lu		
Frequency (MHz)	Reading (dBuV)	Correct Factor(dB/m)	Result (dBuV/m)	Limit (dBuV/m)	Margin (dB)	Remark	Ant.Polar. H / V
2757.000	31.71	5.28	36.99	74.00	-37.01	peak	H
4689.000	30.31	11.37	41.68	74.00	-32.32	peak	H
7419.000	28.75	20.66	49.41	74.00	-24.59	peak	H
2785.000	32.24	5.36	37.60	74.00	-36.40	peak	V
4717.000	31.24	11.43	42.67	74.00	-31.33	peak	V
7475.000	28.14	20.76	48.90	74.00	-25.10	peak	V



Standard:	FCC Part 15E			Test Distance:	3m		
Test item:	Radiated Emission			Power:	AC 120V/60Hz		
Model Number:	PS2 Speaker			Temp.(°C)/Hum.(%RH):	26(°C)/60%RH		
Mode:	Mode 4			Date:	05/02/2013		
Frequency:	5310MHz			Test By:	Fly Lu		
Frequency (MHz)	Reading (dBuV)	Correct Factor(dB/m)	Result (dBuV/m)	Limit (dBuV/m)	Margin (dB)	Remark	Ant.Polar. H / V
2785.000	33.83	5.36	39.19	74.00	-34.81	peak	H
4710.000	30.52	11.41	41.93	74.00	-32.07	peak	H
7454.000	27.52	20.73	48.25	74.00	-25.75	peak	H
2736.000	32.59	5.22	37.81	74.00	-36.19	peak	V
4766.000	30.59	11.56	42.15	74.00	-31.85	peak	V
7510.000	27.36	20.82	48.18	74.00	-25.82	peak	V

Standard:	FCC Part 15E			Test Distance:	3m		
Test item:	Radiated Emission			Power:	AC 120V/60Hz		
Model Number:	PS2 Speaker			Temp.(°C)/Hum.(%RH):	26(°C)/60%RH		
Mode:	Mode 4			Date:	05/02/2013		
Frequency:	5510MHz			Test By:	Fly Lu		
Frequency (MHz)	Reading (dBuV)	Correct Factor(dB/m)	Result (dBuV/m)	Limit (dBuV/m)	Margin (dB)	Remark	Ant.Polar. H / V
2750.000	32.39	5.27	37.66	74.00	-36.34	peak	H
4661.000	29.55	11.29	40.84	74.00	-33.16	peak	H
7489.000	29.83	20.79	50.62	74.00	-23.38	peak	H
2806.000	31.51	5.41	36.92	74.00	-37.08	peak	V
4633.000	30.25	11.22	41.47	74.00	-32.53	peak	V
7475.000	27.45	20.76	48.21	74.00	-25.79	peak	V

Standard:	FCC Part 15E			Test Distance:	3m		
Test item:	Radiated Emission			Power:	AC 120V/60Hz		
Model Number:	PS2 Speaker			Temp.(°C)/Hum.(%RH):	26(°C)/60%RH		
Mode:	Mode 4			Date:	05/02/2013		
Frequency:	5590MHz			Test By:	Fly Lu		
Frequency (MHz)	Reading (dBuV)	Correct Factor(dB/m)	Result (dBuV/m)	Limit (dBuV/m)	Margin (dB)	Remark	Ant.Polar. H / V
2743.000	34.01	5.25	39.26	74.00	-34.74	peak	H
4661.000	29.71	11.29	41.00	74.00	-33.00	peak	H
7538.000	27.20	20.83	48.03	74.00	-25.97	peak	H
2750.000	33.00	5.27	38.27	74.00	-35.73	peak	V
4675.000	30.49	11.33	41.82	74.00	-32.18	peak	V
7573.000	28.39	20.84	49.23	74.00	-24.77	peak	V

Standard:	FCC Part 15E			Test Distance:	3m		
Test item:	Radiated Emission			Power:	AC 120V/60Hz		
Model Number:	PS2 Speaker			Temp.(°C)/Hum.(%RH):	26(°C)/60%RH		
Mode:	Mode 4			Date:	05/02/2013		
Frequency:	5670MHz			Test By:	Fly Lu		
Frequency (MHz)	Reading (dBuV)	Correct Factor(dB/m)	Result (dBuV/m)	Limit (dBuV/m)	Margin (dB)	Remark	Ant.Polar. H / V
2771.000	32.01	5.32	37.33	74.00	-36.67	peak	H
4661.000	29.23	11.29	40.52	74.00	-33.48	peak	H
7573.000	27.64	20.84	48.48	74.00	-25.52	peak	H
2799.000	33.91	5.40	39.31	74.00	-34.69	peak	V
4626.000	31.56	11.20	42.76	74.00	-31.24	peak	V
7538.000	28.94	20.83	49.77	74.00	-24.23	peak	V

Standard:	RSS-Gen	Test Distance:	3m
Test item:	Radiated Emission	Power:	AC 120V/60Hz
Model Number:	PS2 Speaker	Temp.(°C)/Hum.(%RH):	26(°C)/60%RH
Mode:	Mode 5	Date:	05/01/2013
Modulation:	IEEE 802.11a	Test By:	Fly Lu
Frequency:	5260 MHz		

Frequency (MHz)	Reading (dBuV)	Correct Factor(dB/m)	Result (dBuV/m)	Peak Limit (dBuV/m)	AVG. Limit (dBuV/m)	Margin (dB)	Remark	Ant.Polar. H / V
2778.000	33.56	5.34	38.90	74.00	54.00	-35.10	peak	H
4759.000	30.47	11.54	42.01	74.00	54.00	-31.99	peak	H
7370.000	27.49	20.57	48.06	74.00	54.00	-25.94	peak	H
2806.000	33.15	5.41	38.56	74.00	54.00	-35.44	peak	V
4626.000	30.59	11.20	41.79	74.00	54.00	-32.21	peak	V
7475.000	27.39	20.76	48.15	74.00	54.00	-25.85	peak	V

**Band Edge**

Standard:	FCC Part 15E	Test Distance:	3m
Test item:	Radiated Emission	Power:	AC 120V/60Hz
Model Number:	PS2 Speaker	Temp.(°C)/Hum.(%RH):	26(°C)/60%RH
Mode:	Mode 2	Date:	05/01/2013
Frequency:	5180 MHz	Test By:	Fly Lu
Ant.Polar.:	Horizontal		

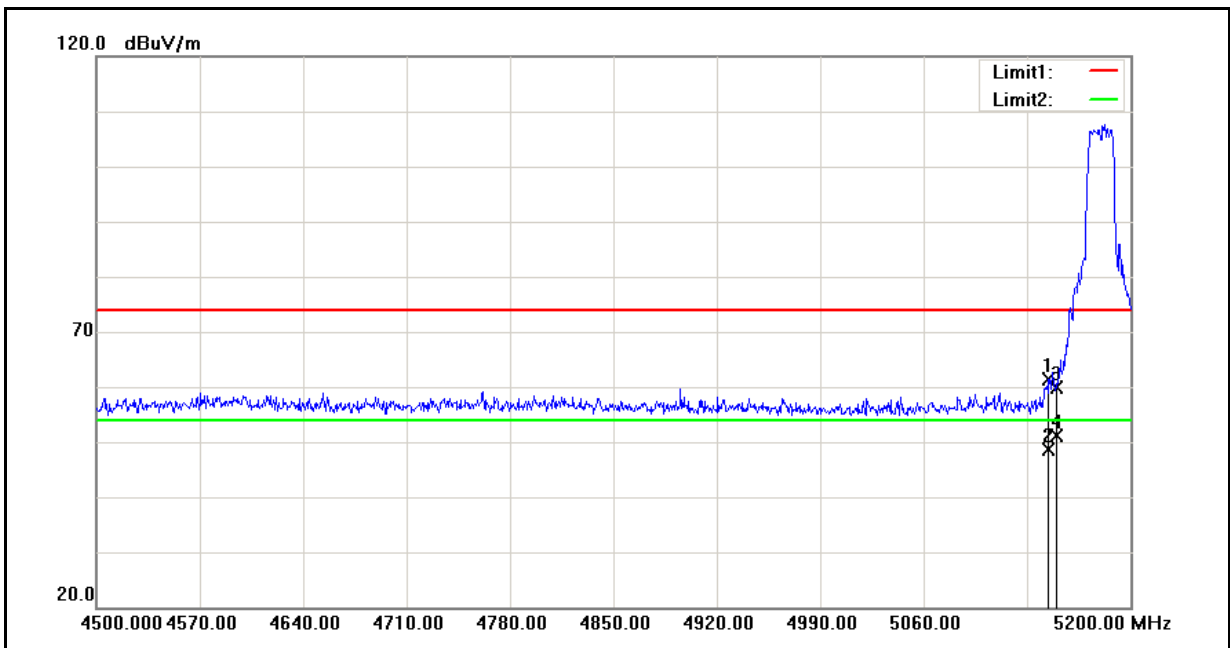

No.	Frequency (MHz)	Reading (dBuV)	Correct Factor(dB/m)	Result (dBuV/m)	Limit (dBuV/m)	Margin (dB)	Remark
1	5144.700	48.59	12.80	61.39	74.00	-12.61	peak
2	5144.700	35.87	12.80	48.67	54.00	-5.33	AVG
3	5150.000	47.17	12.81	59.98	74.00	-14.02	peak
4	5150.000	38.25	12.81	51.06	54.00	-2.94	AVG

Standard:	FCC Part 15E	Test Distance:	3m
Test item:	Radiated Emission	Power:	AC 120V/60Hz
Model Number:	PS2 Speaker	Temp.(°C)/Hum.(%RH):	26(°C)/60%RH
Mode:	Mode 2	Date:	05/01/2013
Frequency:	5180 MHz	Test By:	Fly Lu
Ant.Polar.:	Vertical		

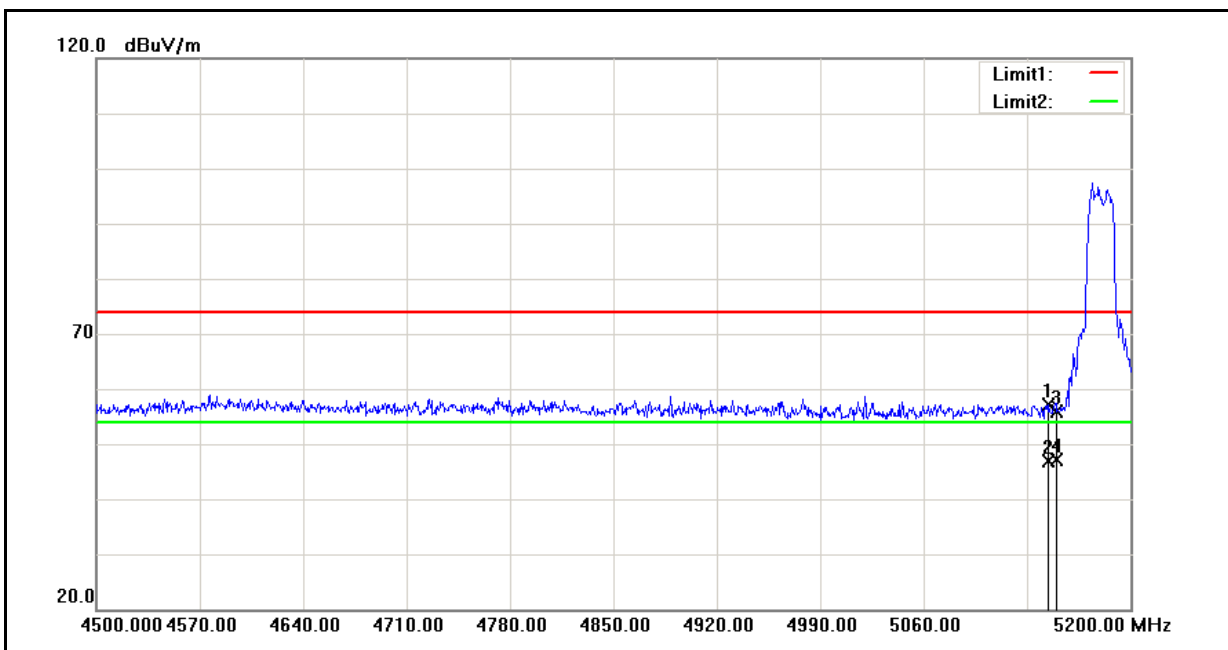

No.	Frequency (MHz)	Reading (dBuV)	Correct Factor(dB/m)	Result (dBuV/m)	Limit (dBuV/m)	Margin (dB)	Remark
1	5144.700	44.22	12.80	57.02	74.00	-16.98	peak
2	5144.700	34.05	12.80	46.85	54.00	-7.15	AVG
3	5150.000	42.97	12.81	55.78	74.00	-18.22	peak
4	5150.000	34.22	12.81	47.03	54.00	-6.97	AVG

Standard:	FCC Part 15E	Test Distance:	3m
Test item:	Radiated Emission	Power:	AC 120V/60Hz
Model Number:	PS2 Speaker	Temp.(°C)/Hum.(%RH):	26(°C)/60%RH
Mode:	Mode 2	Date:	05/01/2013
Frequency:	5320 MHz	Test By:	Fly Lu
Ant.Polar.:	Horizontal		

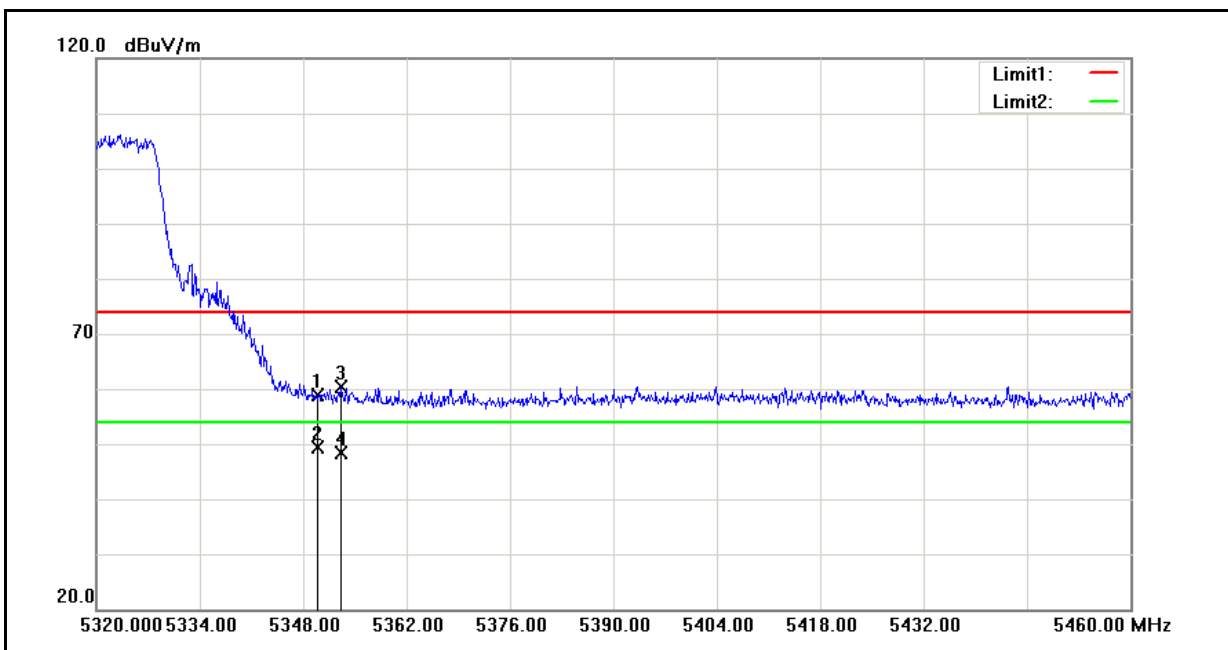

No.	Frequency (MHz)	Reading (dBuV)	Correct Factor(dB/m)	Result (dBuV/m)	Limit (dBuV/m)	Margin (dB)	Remark
1	5350.000	45.30	13.70	59.00	74.00	-15.00	peak
2	5350.000	35.63	13.70	49.33	54.00	-4.67	AVG
3	5353.040	46.63	13.70	60.33	74.00	-13.67	peak
4	5353.040	34.80	13.70	48.50	54.00	-5.50	AVG

Standard:	FCC Part 15E	Test Distance:	3m
Test item:	Radiated Emission	Power:	AC 120V/60Hz
Model Number:	PS2 Speaker	Temp.(°C)/Hum.(%RH):	26(°C)/60%RH
Mode:	Mode 2	Date:	05/01/2013
Frequency:	5320 MHz	Test By:	Fly Lu
Ant.Polar.:	Vertical		

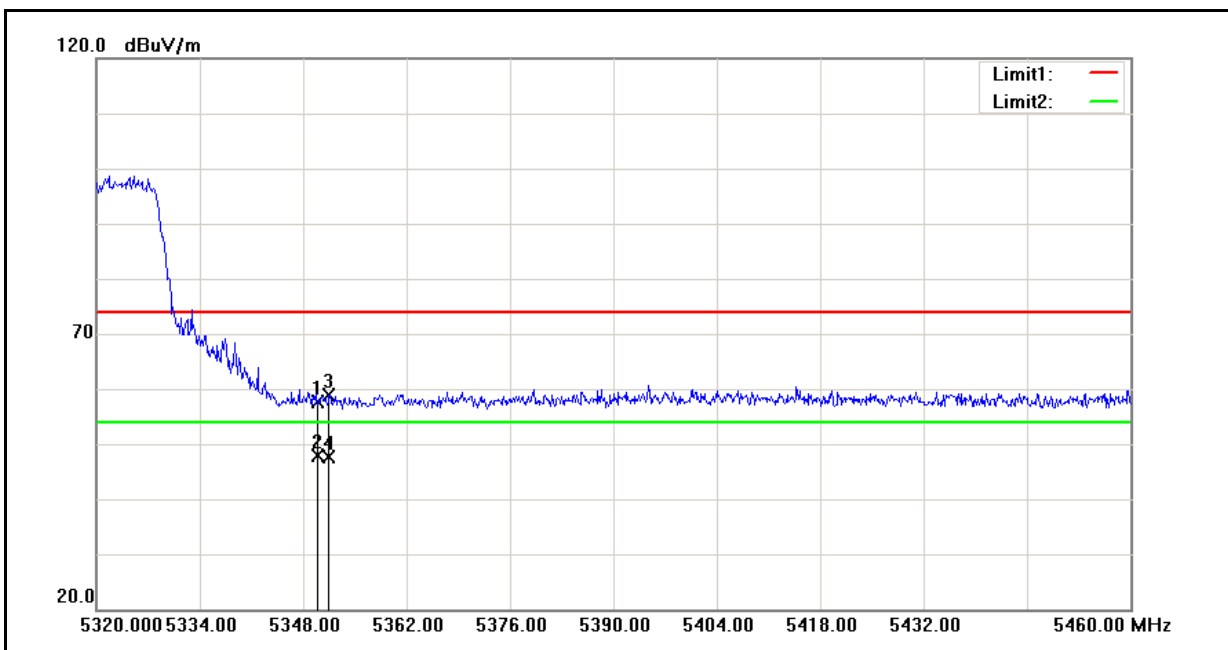

No.	Frequency (MHz)	Reading (dBuV)	Correct Factor(dB/m)	Result (dBuV/m)	Limit (dBuV/m)	Margin (dB)	Remark
1	5350.000	43.84	13.70	57.54	74.00	-16.46	peak
2	5350.000	34.30	13.70	48.00	54.00	-6.00	AVG
3	5351.500	45.21	13.70	58.91	74.00	-15.09	peak
4	5351.500	34.05	13.70	47.75	54.00	-6.25	AVG

Standard:	FCC Part 15E	Test Distance:	3m
Test item:	Radiated Emission	Power:	AC 120V/60Hz
Model Number:	PS2 Speaker	Temp.(°C)/Hum.(%RH):	26(°C)/60%RH
Mode:	Mode 2	Date:	05/01/2013
Frequency:	5500 MHz	Test By:	Fly Lu
Ant.Polar.:	Horizontal		

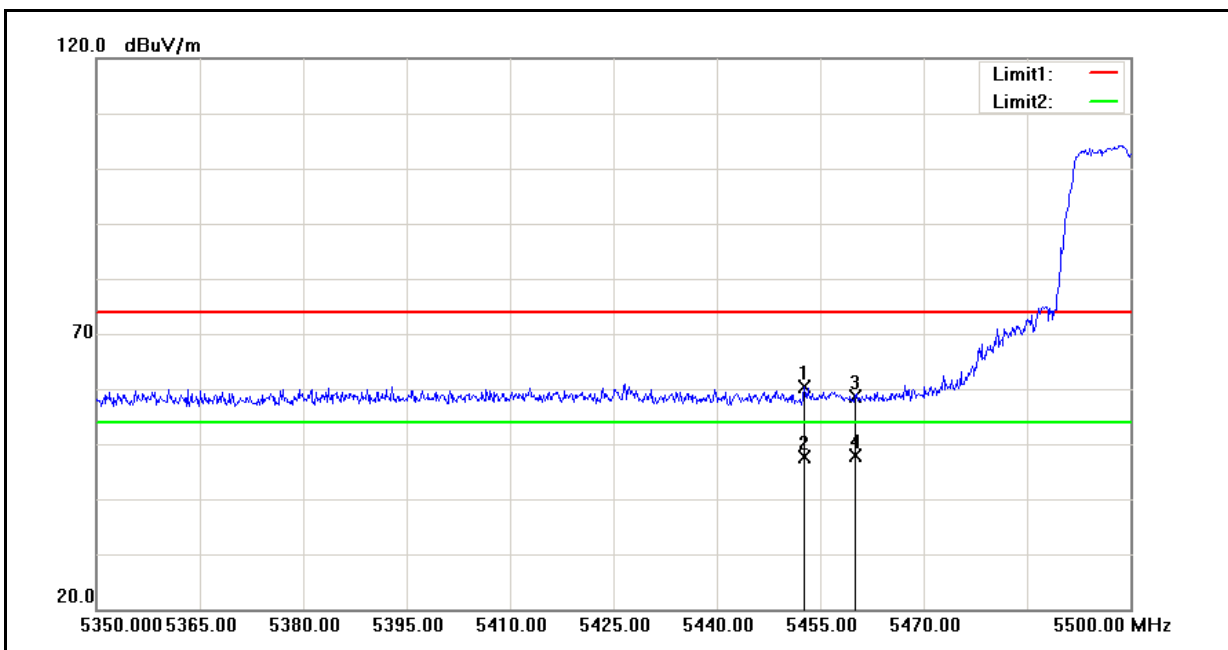

No.	Frequency (MHz)	Reading (dBuV)	Correct Factor(dB/m)	Result (dBuV/m)	Limit (dBuV/m)	Margin (dB)	Remark
1	5452.750	46.17	14.14	60.31	74.00	-13.69	peak
2	5452.750	33.51	14.14	47.65	54.00	-6.35	AVG
3	5460.000	44.40	14.18	58.58	74.00	-15.42	peak
4	5460.000	33.58	14.18	47.76	54.00	-6.24	AVG



Standard:	FCC Part 15E	Test Distance:	3m
Test item:	Radiated Emission	Power:	AC 120V/60Hz
Model Number:	PS2 Speaker	Temp.(°C)/Hum.(%RH):	26(°C)/60%RH
Mode:	Mode 2	Date:	05/01/2013
Frequency:	5500 MHz	Test By:	Fly Lu
Ant.Polar.:	Vertical		

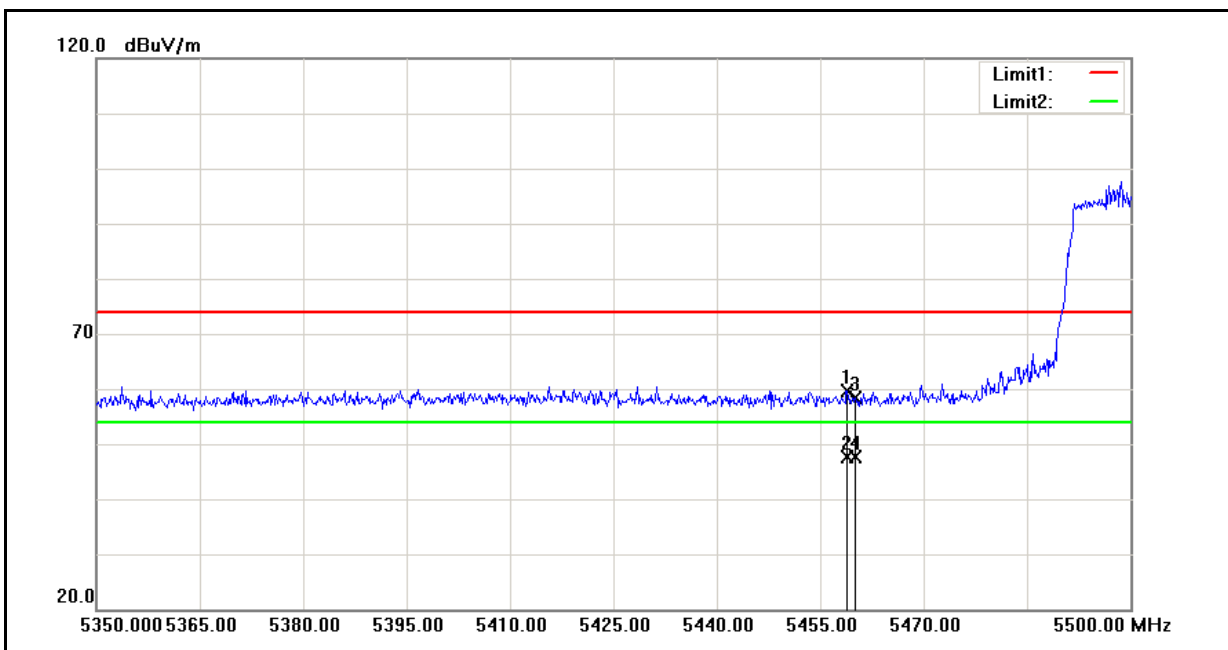

No.	Frequency (MHz)	Reading (dBuV)	Correct Factor(dB/m)	Result (dBuV/m)	Limit (dBuV/m)	Margin (dB)	Remark
1	5458.900	45.41	14.17	59.58	74.00	-14.42	peak
2	5458.900	33.40	14.17	47.57	54.00	-6.43	AVG
3	5460.000	44.12	14.18	58.30	74.00	-15.70	peak
4	5460.000	33.43	14.18	47.61	54.00	-6.39	AVG

Standard:	FCC Part 15E	Test Distance:	3m
Test item:	Radiated Emission	Power:	AC 120V/60Hz
Model Number:	PS2 Speaker	Temp.(°C)/Hum.(%RH):	26(°C)/60%RH
Mode:	Mode 3	Date:	05/01/2013
Frequency:	5180 MHz	Test By:	Fly Lu
Ant.Polar.:	Horizontal		

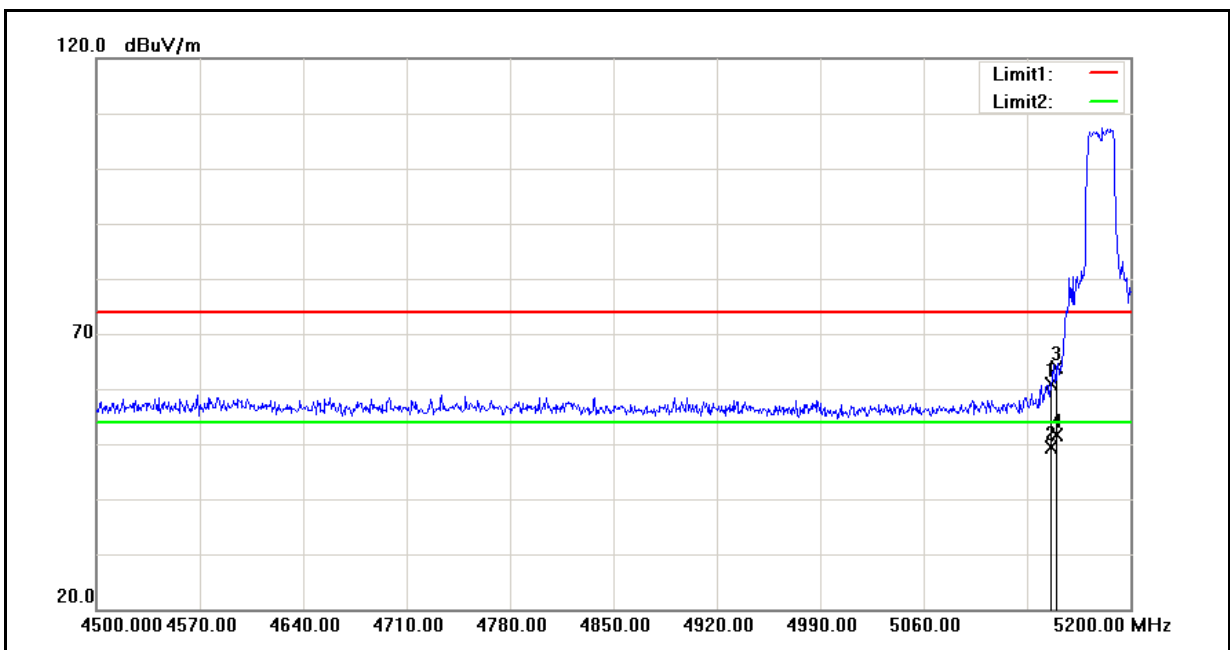

No.	Frequency (MHz)	Reading (dBuV)	Correct Factor(dB/m)	Result (dBuV/m)	Limit (dBuV/m)	Margin (dB)	Remark
1	5146.100	48.02	12.80	60.82	74.00	-13.18	peak
2	5146.100	36.57	12.80	49.37	54.00	-4.63	AVG
3	5150.000	51.01	12.81	63.82	74.00	-10.18	peak
4	5150.000	38.78	12.81	51.59	54.00	-2.41	AVG

Standard:	FCC Part 15E	Test Distance:	3m
Test item:	Radiated Emission	Power:	AC 120V/60Hz
Model Number:	PS2 Speaker	Temp.(°C)/Hum.(%RH):	26(°C)/60%RH
Mode:	Mode 3	Date:	05/01/2013
Frequency:	5180 MHz	Test By:	Fly Lu
Ant.Polar.:	Vertical		

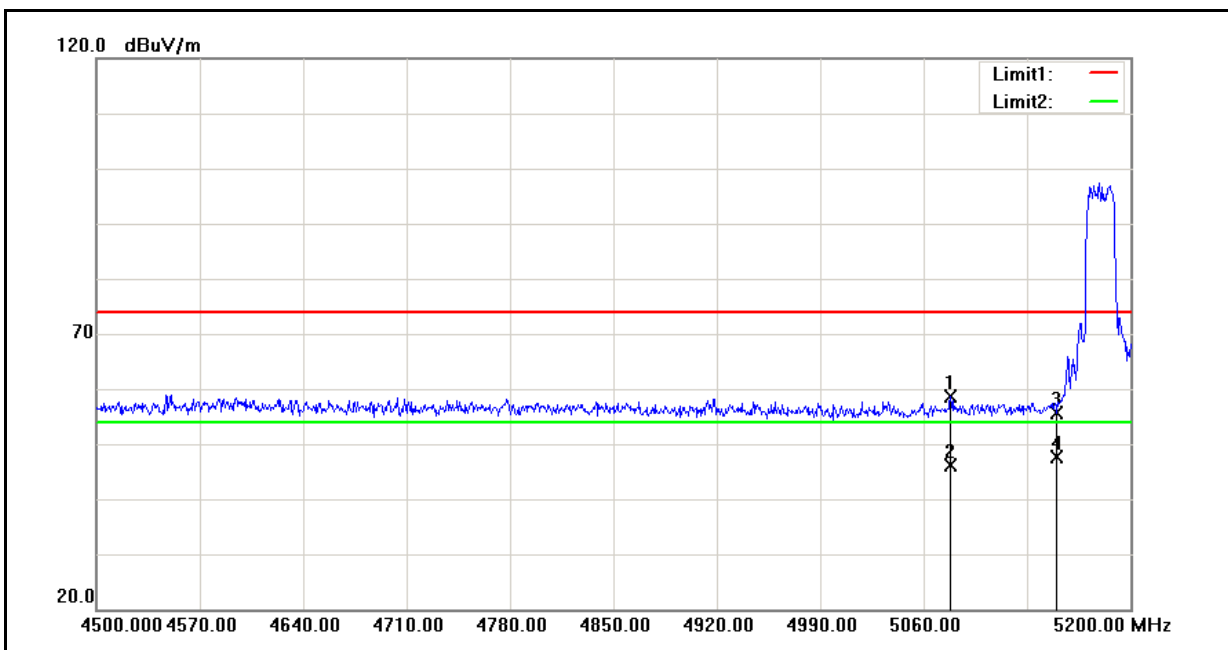

No.	Frequency (MHz)	Reading (dBuV)	Correct Factor(dB/m)	Result (dBuV/m)	Limit (dBuV/m)	Margin (dB)	Remark
1	5078.200	46.21	12.50	58.71	74.00	-15.29	peak
2	5078.200	33.53	12.50	46.03	54.00	-7.97	AVG
3	5150.000	42.91	12.81	55.72	74.00	-18.28	peak
4	5150.000	34.76	12.81	47.57	54.00	-6.43	AVG

Standard:	FCC Part 15E	Test Distance:	3m
Test item:	Radiated Emission	Power:	AC 120V/60Hz
Model Number:	PS2 Speaker	Temp.(°C)/Hum.(%RH):	26(°C)/60%RH
Mode:	Mode 3	Date:	05/01/2013
Frequency:	5320 MHz	Test By:	Fly Lu
Ant.Polar.:	Horizontal		

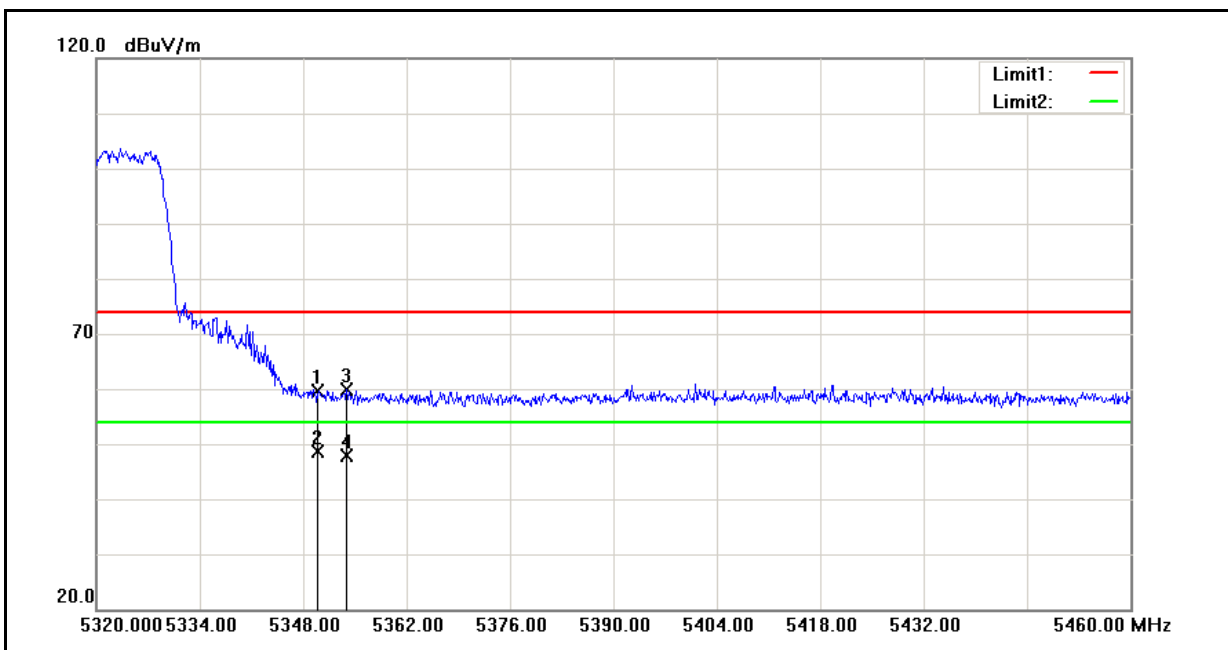

No.	Frequency (MHz)	Reading (dBuV)	Correct Factor(dB/m)	Result (dBuV/m)	Limit (dBuV/m)	Margin (dB)	Remark
1	5350.000	45.98	13.70	59.68	74.00	-14.32	peak
2	5350.000	34.98	13.70	48.68	54.00	-5.32	AVG
3	5353.880	46.20	13.71	59.91	74.00	-14.09	peak
4	5353.880	34.11	13.71	47.82	54.00	-6.18	AVG

Standard:	FCC Part 15E	Test Distance:	3m
Test item:	Radiated Emission	Power:	AC 120V/60Hz
Model Number:	PS2 Speaker	Temp.(°C)/Hum.(%RH):	26(°C)/60%RH
Mode:	Mode 3	Date:	05/01/2013
Frequency:	5320 MHz	Test By:	Fly Lu
Ant.Polar.:	Vertical		

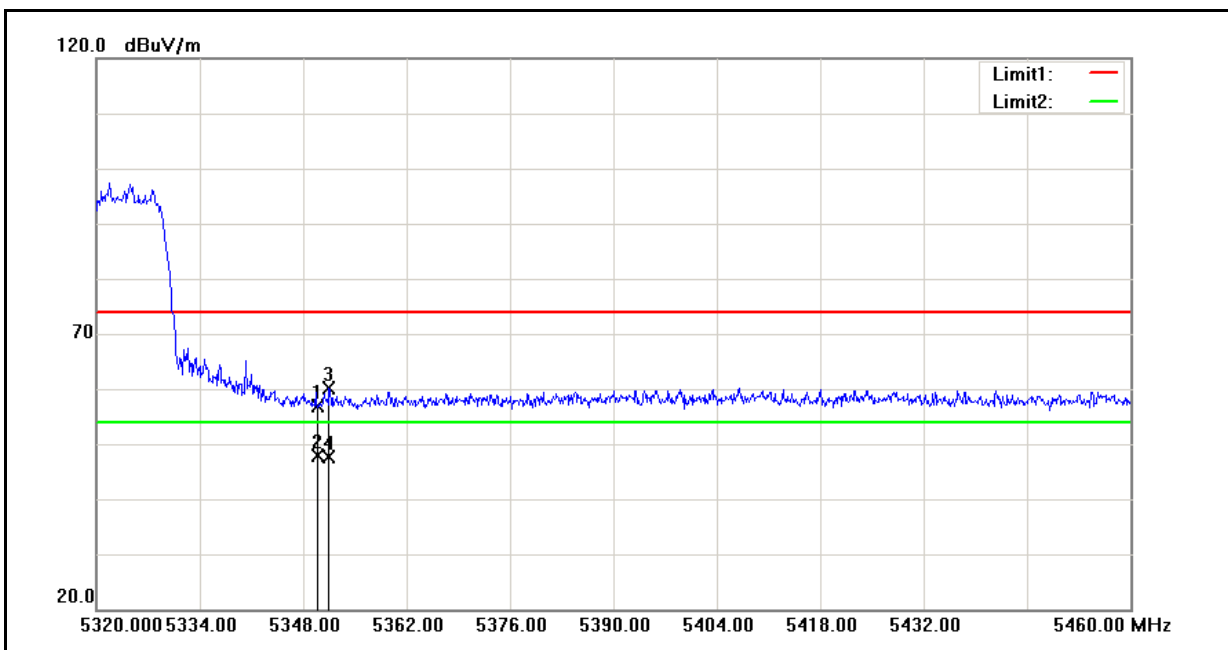

No.	Frequency (MHz)	Reading (dBuV)	Correct Factor(dB/m)	Result (dBuV/m)	Limit (dBuV/m)	Margin (dB)	Remark
1	5350.000	43.21	13.70	56.91	74.00	-17.09	peak
2	5350.000	34.21	13.70	47.91	54.00	-6.09	AVG
3	5351.500	46.45	13.70	60.15	74.00	-13.85	peak
4	5351.500	34.00	13.70	47.70	54.00	-6.30	AVG

Standard:	FCC Part 15E	Test Distance:	3m
Test item:	Radiated Emission	Power:	AC 120V/60Hz
Model Number:	PS2 Speaker	Temp.(°C)/Hum.(%RH):	26(°C)/60%RH
Mode:	Mode 3	Date:	05/01/2013
Frequency:	5500 MHz	Test By:	Fly Lu
Ant.Polar.:	Horizontal		

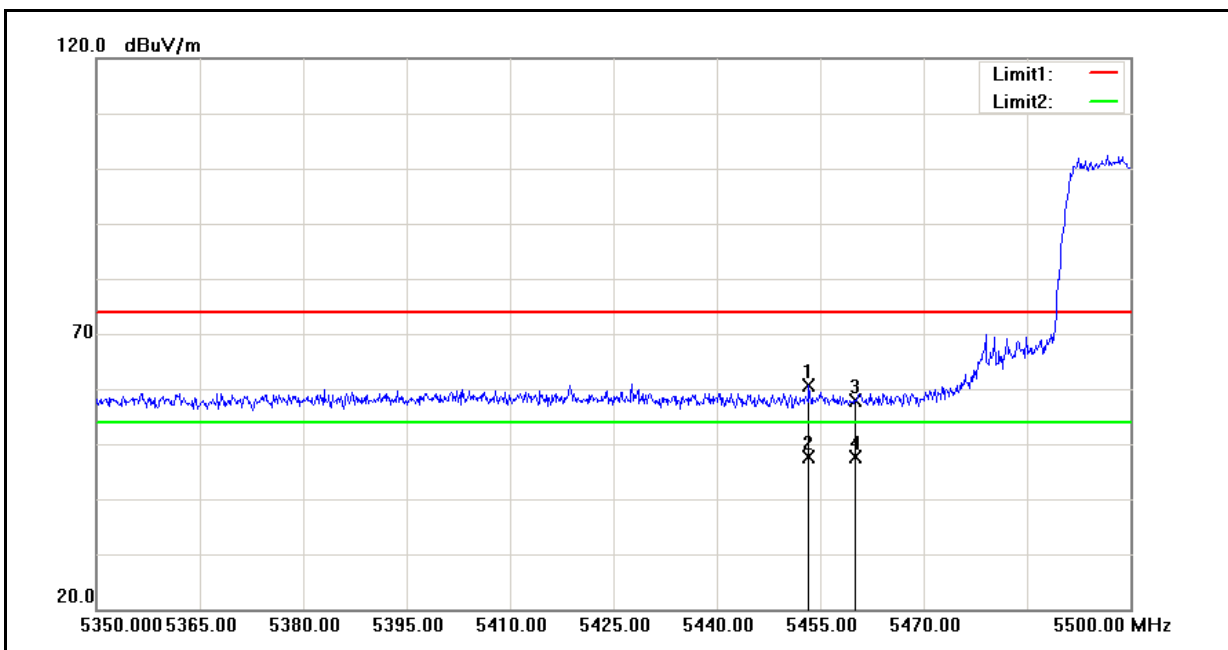

No.	Frequency (MHz)	Reading (dBuV)	Correct Factor(dB/m)	Result (dBuV/m)	Limit (dBuV/m)	Margin (dB)	Remark
1	5453.350	46.48	14.14	60.62	74.00	-13.38	peak
2	5453.350	33.53	14.14	47.67	54.00	-6.33	AVG
3	5460.000	43.77	14.18	57.95	74.00	-16.05	peak
4	5460.000	33.48	14.18	47.66	54.00	-6.34	AVG

Standard:	FCC Part 15E	Test Distance:	3m
Test item:	Radiated Emission	Power:	AC 120V/60Hz
Model Number:	PS2 Speaker	Temp.(°C)/Hum.(%RH):	26(°C)/60%RH
Mode:	Mode 3	Date:	05/01/2013
Frequency:	5500 MHz	Test By:	Fly Lu
Ant.Polar.:	Vertical		

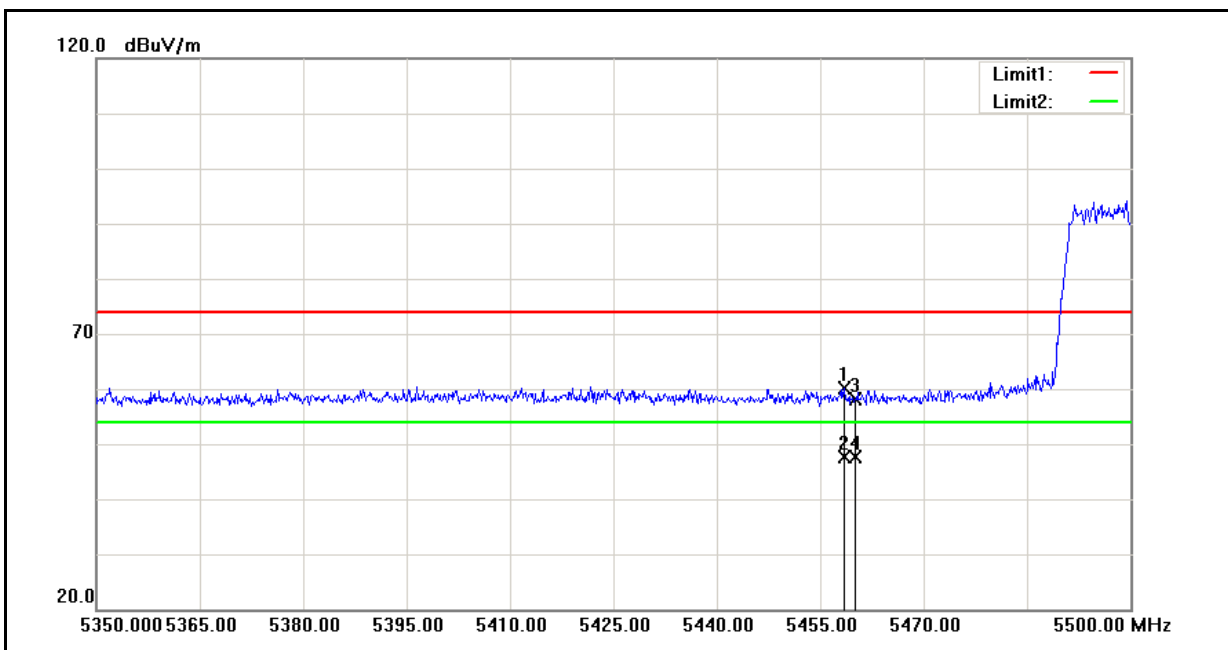

No.	Frequency (MHz)	Reading (dBuV)	Correct Factor(dB/m)	Result (dBuV/m)	Limit (dBuV/m)	Margin (dB)	Remark
1	5458.450	46.05	14.17	60.22	74.00	-13.78	peak
2	5458.450	33.41	14.17	47.58	54.00	-6.42	AVG
3	5460.000	43.95	14.18	58.13	74.00	-15.87	peak
4	5460.000	33.37	14.18	47.55	54.00	-6.45	AVG

Standard:	FCC Part 15E	Test Distance:	3m
Test item:	Radiated Emission	Power:	AC 120V/60Hz
Model Number:	PS2 Speaker	Temp.(°C)/Hum.(%RH):	26(°C)/60%RH
Mode:	Mode 4	Date:	05/01/2013
Frequency:	5190 MHz	Test By:	Fly Lu
Ant.Polar.:	Horizontal		

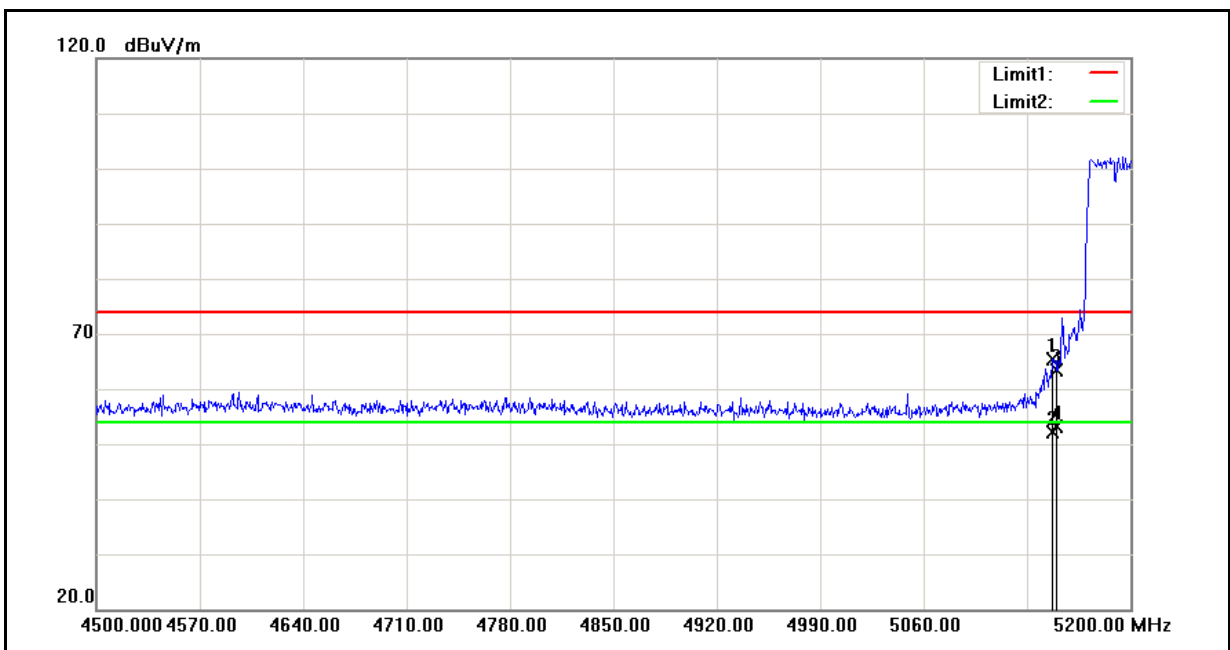

No.	Frequency (MHz)	Reading (dBuV)	Correct Factor(dB/m)	Result (dBuV/m)	Limit (dBuV/m)	Margin (dB)	Remark
1	5147.500	52.47	12.81	65.28	74.00	-8.72	peak
2	5147.500	39.40	12.81	52.21	54.00	-1.79	AVG
3	5150.000	50.56	12.81	63.37	74.00	-10.63	peak
4	5150.000	40.32	12.81	53.13	54.00	-0.87	AVG



Standard:	FCC Part 15E	Test Distance:	3m
Test item:	Radiated Emission	Power:	AC 120V/60Hz
Model Number:	PS2 Speaker	Temp.(°C)/Hum.(%RH):	26(°C)/60%RH
Mode:	Mode 4	Date:	05/01/2013
Frequency:	5190 MHz	Test By:	Fly Lu
Ant.Polar.:	Vertical		

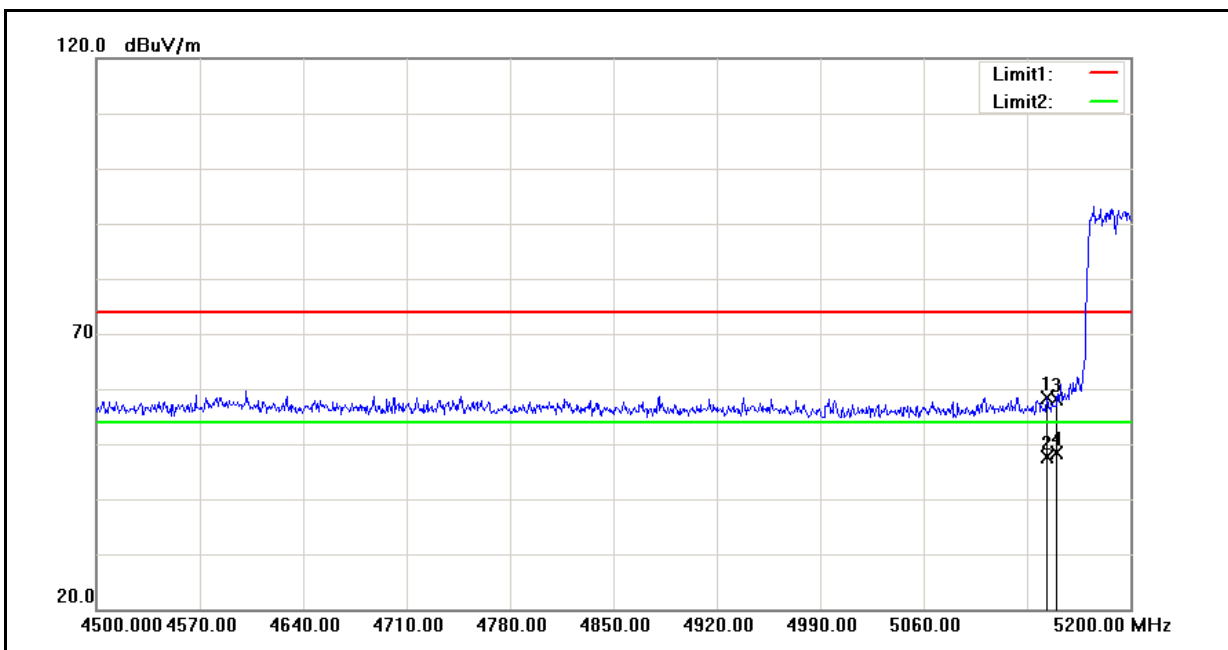

No.	Frequency (MHz)	Reading (dBuV)	Correct Factor(dB/m)	Result (dBuV/m)	Limit (dBuV/m)	Margin (dB)	Remark
1	5143.300	45.66	12.78	58.44	74.00	-15.56	peak
2	5143.300	34.81	12.78	47.59	54.00	-6.41	AVG
3	5150.000	45.22	12.81	58.03	74.00	-15.97	peak
4	5150.000	35.63	12.81	48.44	54.00	-5.56	AVG

Standard:	FCC Part 15E	Test Distance:	3m
Test item:	Radiated Emission	Power:	AC 120V/60Hz
Model Number:	PS2 Speaker	Temp.(°C)/Hum.(%RH):	26(°C)/60%RH
Mode:	Mode 4	Date:	05/01/2013
Frequency:	5310 MHz	Test By:	Fly Lu
Ant.Polar.:	Horizontal		

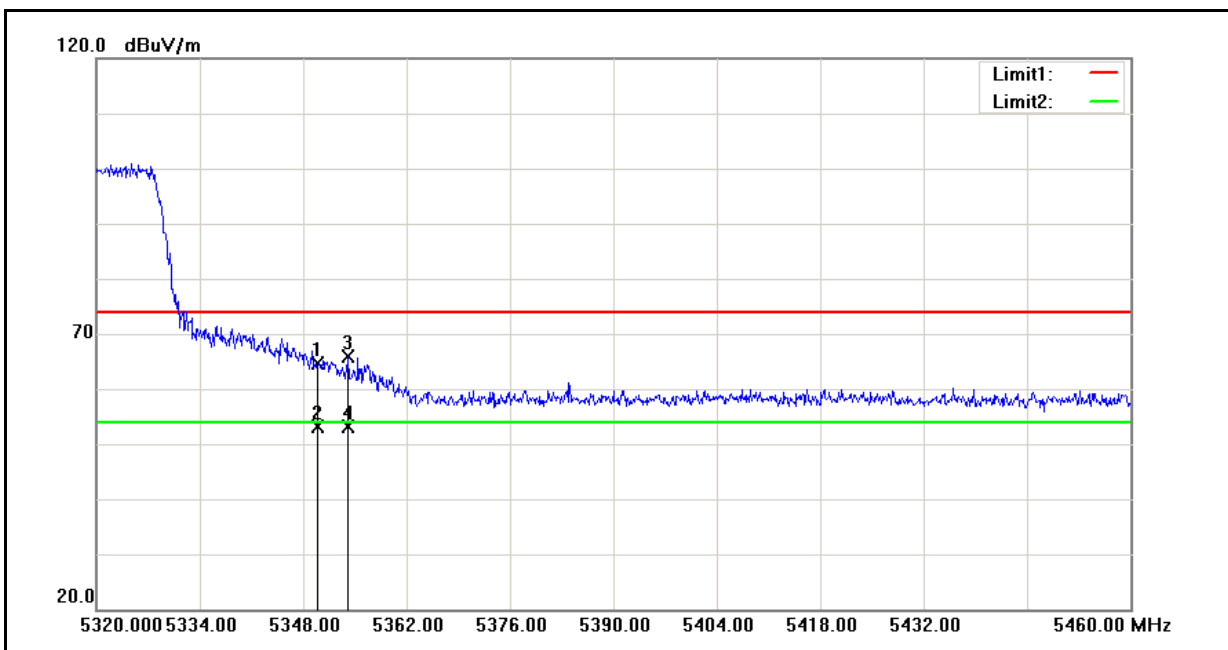

No.	Frequency (MHz)	Reading (dBuV)	Correct Factor(dB/m)	Result (dBuV/m)	Limit (dBuV/m)	Margin (dB)	Remark
1	5350.000	50.84	13.70	64.54	74.00	-9.46	peak
2	5350.000	39.46	13.70	53.16	54.00	-0.84	AVG
3	5354.020	52.05	13.71	65.76	74.00	-8.24	peak
4	5354.020	39.31	13.71	53.02	54.00	-0.98	AVG

Standard:	FCC Part 15E	Test Distance:	3m
Test item:	Radiated Emission	Power:	AC 120V/60Hz
Model Number:	PS2 Speaker	Temp.(°C)/Hum.(%RH):	26(°C)/60%RH
Mode:	Mode 4	Date:	05/01/2013
Frequency:	5310 MHz	Test By:	Fly Lu
Ant.Polar.:	Vertical		

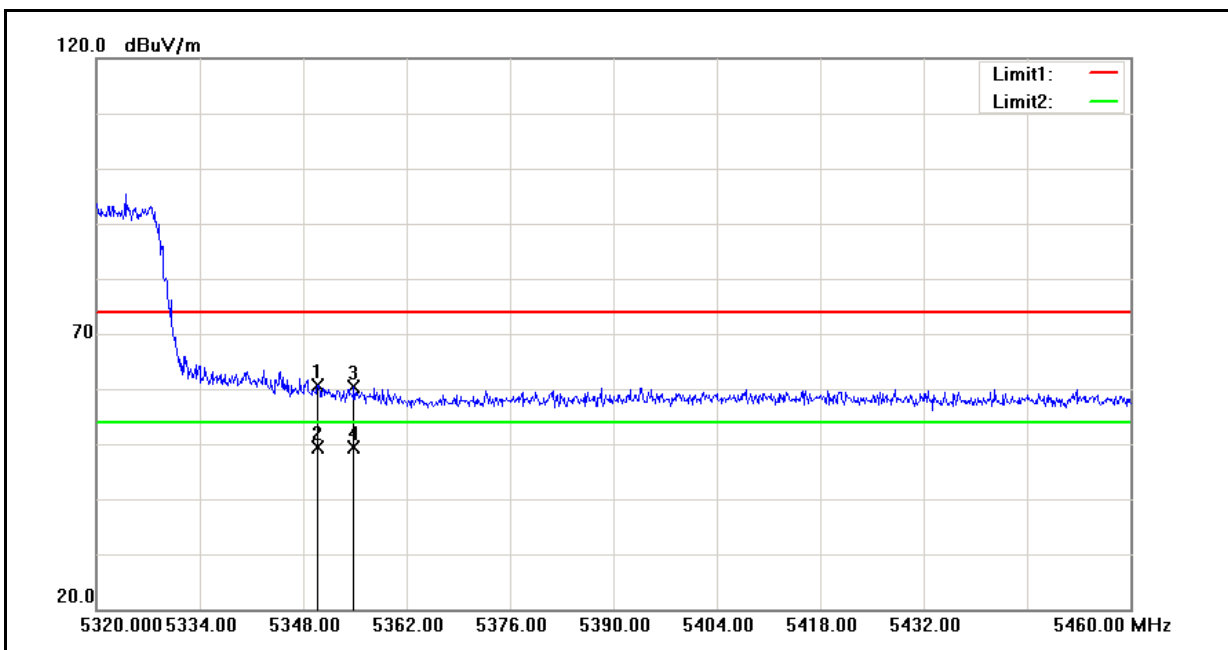

No.	Frequency (MHz)	Reading (dBuV)	Correct Factor(dB/m)	Result (dBuV/m)	Limit (dBuV/m)	Margin (dB)	Remark
1	5350.000	46.83	13.70	60.53	74.00	-13.47	peak
2	5350.000	35.64	13.70	49.34	54.00	-4.66	AVG
3	5354.860	46.63	13.71	60.34	74.00	-13.66	peak
4	5354.860	35.56	13.71	49.27	54.00	-4.73	AVG

Standard:	FCC Part 15E	Test Distance:	3m
Test item:	Radiated Emission	Power:	AC 120V/60Hz
Model Number:	PS2 Speaker	Temp.(°C)/Hum.(%RH):	26(°C)/60%RH
Mode:	Mode 4	Date:	05/01/2013
Frequency:	5510 MHz	Test By:	Fly Lu
Ant.Polar.:	Horizontal		

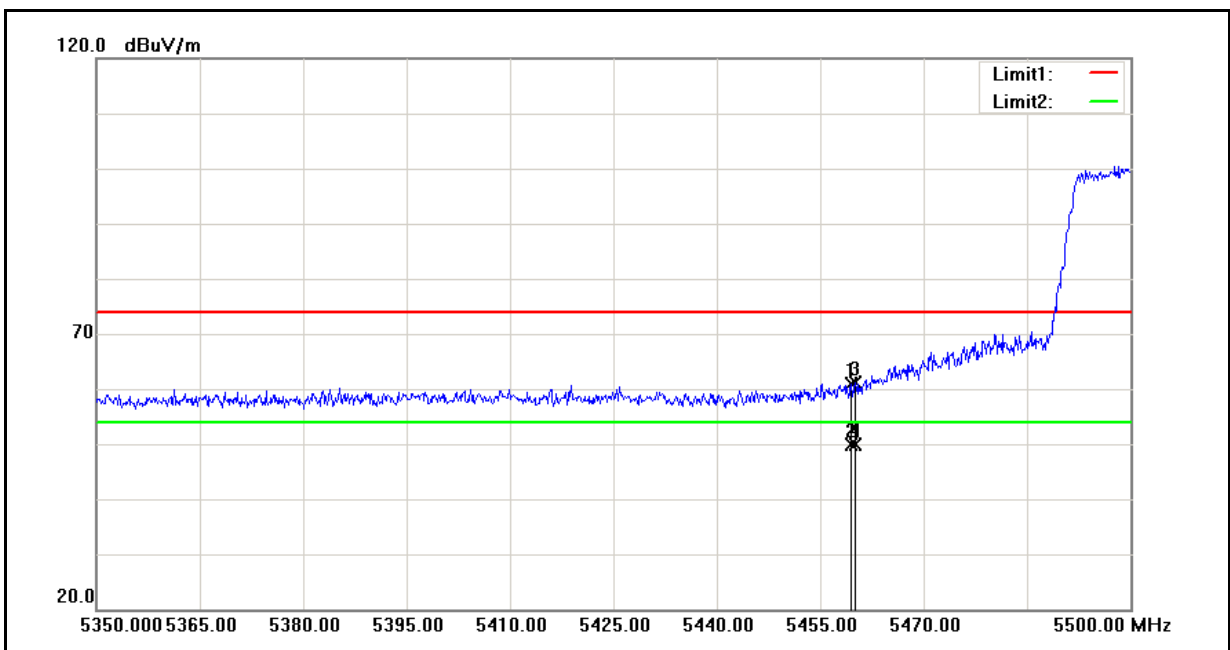

No.	Frequency (MHz)	Reading (dBuV)	Correct Factor(dB/m)	Result (dBuV/m)	Limit (dBuV/m)	Margin (dB)	Remark
1	5459.500	46.75	14.17	60.92	74.00	-13.08	peak
2	5459.500	35.67	14.17	49.84	54.00	-4.16	AVG
3	5460.000	46.87	14.18	61.05	74.00	-12.95	peak
4	5460.000	35.76	14.18	49.94	54.00	-4.06	AVG

Standard:	FCC Part 15E	Test Distance:	3m
Test item:	Radiated Emission	Power:	AC 120V/60Hz
Model Number:	PS2 Speaker	Temp.(°C)/Hum.(%RH):	26(°C)/60%RH
Mode:	Mode 4	Date:	05/01/2013
Frequency:	5510 MHz	Test By:	Fly Lu
Ant.Polar.:	Vertical		

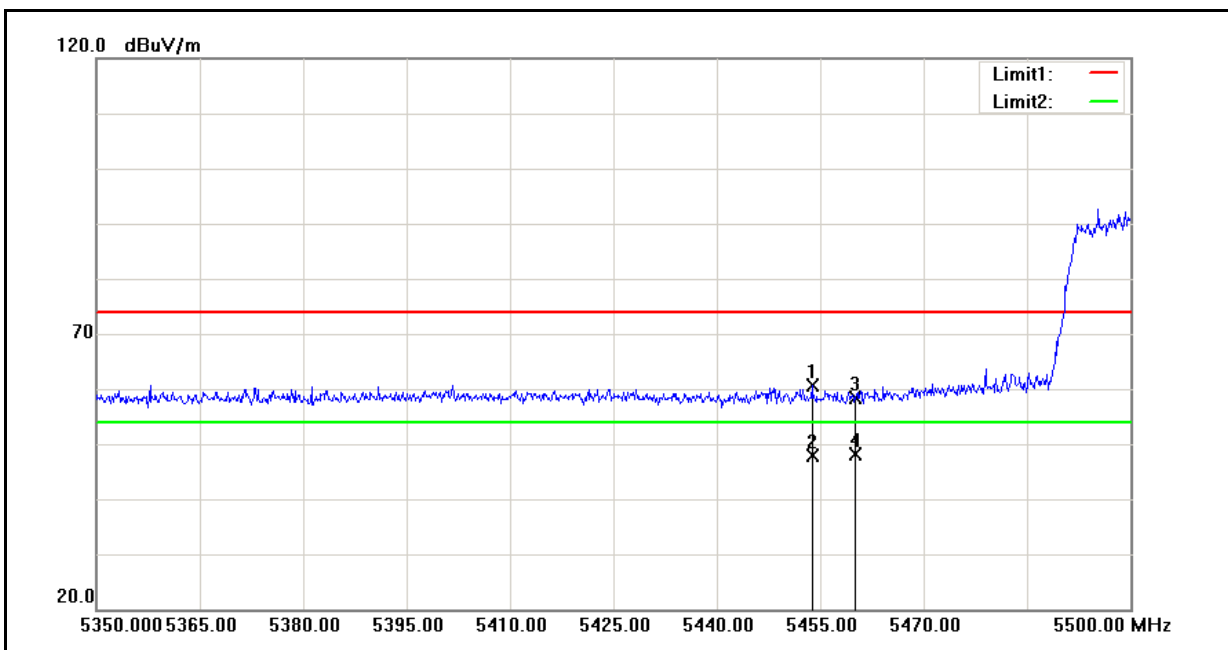

No.	Frequency (MHz)	Reading (dBuV)	Correct Factor(dB/m)	Result (dBuV/m)	Limit (dBuV/m)	Margin (dB)	Remark
1	5453.800	46.50	14.14	60.64	74.00	-13.36	peak
2	5453.800	33.64	14.14	47.78	54.00	-6.22	AVG
3	5460.000	44.25	14.18	58.43	74.00	-15.57	peak
4	5460.000	33.93	14.18	48.11	54.00	-5.89	AVG

## 6 Maximum Conducted Output Power / EIRP Measurement

### 6.1. Limit

#### FCC

Frequency Range (MHz)	Conducted Power Limit
5.150 ~ 5.250 GHz	The lesser of 50mW (17dBm) or 4dBm + 10logB
5.250 ~ 5.350 GHz	The lesser of 250mW (24dBm) or 11dBm + 10logB
5.470 ~ 5.725 GHz	The lesser of 250mW (24dBm) or 11dBm + 10logB

Note: Where B is the 26dB emission bandwidth in MHz.

#### CANADA

Frequency Range (MHz)	EIRP Limit
5.150 ~ 5.250 GHz	The lesser of 200mW (23dBm) or 10 + 10 log <sub>10</sub> B, dBm
5.250 ~ 5.350 GHz	The lesser of 250 mW (24dBm) or 11 + 10 log <sub>10</sub> B, dBm
5.470 ~ 5.725 GHz	The lesser of 250 mW (24dBm) or 11 + 10 log <sub>10</sub> B, dBm

Note: Where B is the 99% emission bandwidth in MHz

### 6.2. Test Setup

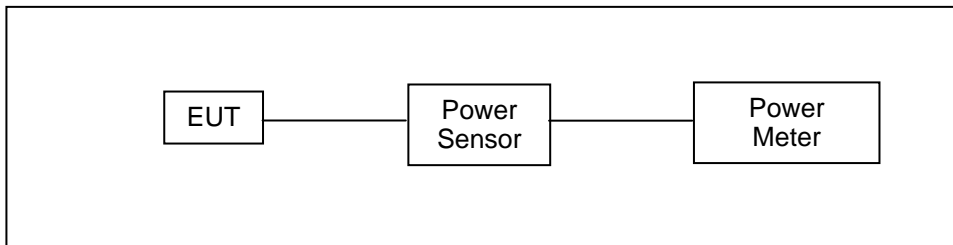

### 6.3. Test Instruments

Equipment	Manufacturer	Model Number	Serial Number	Cal. Date	Remark
Power Sensor	Anritsu	MA2411B	1126022	08/14/2012	(1)
Power Meter	Anritsu	ML2495A	1135009	08/14/2012	(1)
Test Site	ATL	TE02	TE02	N.C.R.	-----

Remark: (1) Calibration period 1 year. (2) Calibration period 2 years.

NOTE: N.C.R. = No Calibration Request.

### 6.4. Test Procedure

The test is performed in accordance with KDB789033: D01 General UNII Test Procedures v01r03, Guidelines for Compliance Testing of Unlicensed National Information Infrastructure (U-NII) Devices - Part 15, Subpart E.

**6.5. Test Result**

Model Number		PS2 Speaker									
Test Item		Maximum Conducted Output Power									
Test Mode		Mode 2: IEEE 802.11a Link Mode									
Date of Test		04/29/2013				Test Site		TE02			
Frequency (MHz)	Data Rate	Average Power				Limit (dBm)	EIRP				Limit (dBm)
		CON 1		CON 2			CON 1		CON 2		
		(dBm)	(W)	(dBm)	(W)		(dBm)	(W)	(dBm)	(W)	
5180.0	6M	13.35	0.022	13.20	0.021	< 17	17.42	0.055	18.58	0.072	< 23
5200.0		13.79	0.024	13.64	0.023	< 17	17.86	0.061	19.02	0.080	< 23
5220.0		13.20	0.021	13.05	0.020	< 17	17.27	0.053	18.43	0.070	< 23
5240.0		13.34	0.022	13.19	0.021	< 17	17.41	0.055	18.57	0.072	< 23
5260.0		13.60	0.023	13.46	0.022	< 24	17.67	0.058	18.84	0.077	< 30
5280.0		13.52	0.022	13.38	0.022	< 24	17.59	0.057	18.76	0.075	< 30
5300.0		13.08	0.020	12.94	0.020	< 24	17.15	0.052	18.32	0.068	< 30
5320.0		12.25	0.017	12.11	0.016	< 24	16.32	0.043	17.49	0.056	< 30
5500.0		12.10	0.016	12.02	0.016	< 24	16.17	0.041	17.40	0.055	< 30
5520.0		12.05	0.016	11.97	0.016	< 24	16.12	0.041	17.35	0.054	< 30
5540.0		12.14	0.016	12.06	0.016	< 24	16.21	0.042	17.44	0.055	< 30
5560.0		12.09	0.016	12.01	0.016	< 24	16.16	0.041	17.39	0.055	< 30
5580.0		12.04	0.016	11.96	0.016	< 24	16.11	0.041	17.34	0.054	< 30
5600.0		11.84	0.015	11.76	0.015	< 24	15.91	0.039	17.14	0.052	< 30
5620.0		11.83	0.015	11.75	0.015	< 24	15.90	0.039	17.13	0.052	< 30
5640.0		11.81	0.015	11.73	0.015	< 24	15.88	0.039	17.11	0.051	< 30
5660.0		11.85	0.015	11.77	0.015	< 24	15.92	0.039	17.15	0.052	< 30
5680.0		11.78	0.015	11.70	0.015	< 24	15.85	0.038	17.08	0.051	< 30
5700.0		12.22	0.017	12.14	0.016	< 24	16.29	0.043	17.52	0.056	< 30
5180.0		54M	13.23	0.021	13.09	0.020	< 17	17.30	0.054	18.47	0.070
5200.0	13.67		0.023	13.53	0.023	< 17	17.74	0.059	18.91	0.078	< 23
5220.0	13.08		0.020	12.94	0.020	< 17	17.15	0.052	18.32	0.068	< 23
5240.0	13.22		0.021	13.08	0.020	< 17	17.29	0.054	18.46	0.070	< 23
5260.0	13.49		0.022	13.35	0.022	< 24	17.56	0.057	18.73	0.075	< 30
5280.0	13.41		0.022	13.27	0.021	< 24	17.48	0.056	18.65	0.073	< 30
5300.0	12.97		0.020	12.83	0.019	< 24	17.04	0.051	18.21	0.066	< 30
5320.0	12.14		0.016	12.00	0.016	< 24	16.21	0.042	17.38	0.055	< 30
5500.0	11.97		0.016	11.91	0.016	< 24	16.04	0.040	17.29	0.054	< 30
5520.0	11.92		0.016	11.86	0.015	< 24	15.99	0.040	17.24	0.053	< 30
5540.0	12.01		0.016	11.95	0.016	< 24	16.08	0.041	17.33	0.054	< 30
5560.0	12.01		0.016	11.90	0.015	< 24	16.08	0.041	17.28	0.053	< 30
5580.0	11.96		0.016	11.85	0.015	< 24	16.03	0.040	17.23	0.053	< 30
5600.0	11.76		0.015	11.65	0.015	< 24	15.83	0.038	17.03	0.050	< 30
5620.0	11.75		0.015	11.64	0.015	< 24	15.82	0.038	17.02	0.050	< 30
5640.0	11.73		0.015	11.62	0.015	< 24	15.80	0.038	17.00	0.050	< 30
5660.0	11.77		0.015	11.66	0.015	< 24	15.84	0.038	17.04	0.051	< 30
5680.0	11.70		0.015	11.59	0.014	< 24	15.77	0.038	16.97	0.050	< 30
5700.0	12.09		0.016	12.03	0.016	< 24	16.16	0.041	17.41	0.055	< 30

EIRP = Conducted Average Power + Antenna Gain

Model Number		PS2 Speaker									
Test Item		Maximum Conducted Output Power									
Test Mode		Mode 3: IEEE 802.11n 20MHz Link Mode									
Date of Test		04/29/2013					Test Site		TE02		
Frequency (MHz)	Data Rate	Average Power				Limit (dBm)	EIRP				Limit (dBm)
		CON 1		CON 2			CON 1		CON 2		
		(dBm)	(W)	(dBm)	(W)		(dBm)	(W)	(dBm)	(W)	
5180.0	6.5M	11.68	0.015	11.61	0.014	< 17	15.75	0.038	16.99	0.050	< 23
5200.0		12.16	0.016	12.09	0.016	< 17	16.23	0.042	17.47	0.056	< 23
5220.0		12.01	0.016	11.94	0.016	< 17	16.08	0.041	17.32	0.054	< 23
5240.0		11.89	0.015	11.82	0.015	< 17	15.96	0.039	17.20	0.052	< 23
5260.0		11.82	0.015	11.72	0.015	< 24	15.89	0.039	17.10	0.051	< 30
5280.0		11.74	0.015	11.64	0.015	< 24	15.81	0.038	17.02	0.050	< 30
5300.0		10.58	0.011	10.48	0.011	< 24	14.65	0.029	15.86	0.039	< 30
5320.0		10.23	0.011	10.13	0.010	< 24	14.30	0.027	15.51	0.036	< 30
5500.0		10.22	0.011	10.13	0.010	< 24	14.29	0.027	15.51	0.036	< 30
5520.0		10.13	0.010	10.04	0.010	< 24	14.20	0.026	15.42	0.035	< 30
5540.0		10.18	0.010	10.09	0.010	< 24	14.25	0.027	15.47	0.035	< 30
5560.0		10.08	0.010	9.99	0.010	< 24	14.15	0.026	15.37	0.034	< 30
5580.0		9.76	0.009	9.67	0.009	< 24	13.83	0.024	15.05	0.032	< 30
5600.0		10.18	0.010	10.09	0.010	< 24	14.25	0.027	15.47	0.035	< 30
5620.0		10.09	0.010	10.00	0.010	< 24	14.16	0.026	15.38	0.035	< 30
5640.0		10.12	0.010	10.03	0.010	< 24	14.19	0.026	15.41	0.035	< 30
5660.0		9.99	0.010	9.90	0.010	< 24	14.06	0.025	15.28	0.034	< 30
5680.0		9.72	0.009	9.63	0.009	< 24	13.79	0.024	15.01	0.032	< 30
5700.0		9.61	0.009	9.56	0.009	< 24	13.68	0.023	14.94	0.031	< 30
5180.0		65M	11.58	0.014	11.51	0.014	< 17	15.65	0.037	16.89	0.049
5200.0	12.06		0.016	11.99	0.016	< 17	16.13	0.041	17.37	0.055	< 23
5220.0	11.91		0.016	11.84	0.015	< 17	15.98	0.040	17.22	0.053	< 23
5240.0	11.79		0.015	11.72	0.015	< 17	15.86	0.039	17.10	0.051	< 23
5260.0	11.69		0.015	11.59	0.014	< 24	15.76	0.038	16.97	0.050	< 30
5280.0	11.61		0.014	11.51	0.014	< 24	15.68	0.037	16.89	0.049	< 30
5300.0	10.45		0.011	10.35	0.011	< 24	14.52	0.028	15.73	0.037	< 30
5320.0	10.10		0.010	10.00	0.010	< 24	14.17	0.026	15.38	0.035	< 30
5500.0	10.10		0.010	10.07	0.010	< 24	14.17	0.026	15.45	0.035	< 30
5520.0	10.01		0.010	9.98	0.010	< 24	14.08	0.026	15.36	0.034	< 30
5540.0	10.06		0.010	10.03	0.010	< 24	14.13	0.026	15.41	0.035	< 30
5560.0	9.96		0.010	9.93	0.010	< 24	14.03	0.025	15.31	0.034	< 30
5580.0	9.64		0.009	9.61	0.009	< 24	13.71	0.023	14.99	0.032	< 30
5600.0	10.06		0.010	10.03	0.010	< 24	14.13	0.026	15.41	0.035	< 30
5620.0	9.97		0.010	9.94	0.010	< 24	14.04	0.025	15.32	0.034	< 30
5640.0	10.00		0.010	9.97	0.010	< 24	14.07	0.026	15.35	0.034	< 30
5660.0	9.87		0.010	9.84	0.010	< 24	13.94	0.025	15.22	0.033	< 30
5680.0	9.60		0.009	9.57	0.009	< 24	13.67	0.023	14.95	0.031	< 30
5700.0	9.59		0.009	9.52	0.009	< 24	13.66	0.023	14.90	0.031	< 30

EIRP = Conducted Average Power + Antenna Gain



Model Number		PS2 Speaker									
Test Item		Maximum Conducted Output Power									
Test Mode		Mode 4: IEEE 802.11n 40MHz Link Mode									
Date of Test		04/29/2013					Test Site		TE02		
Frequency (MHz)	Data Rate	Average Power				Limit (dBm)	EIRP				Limit (dBm)
		CON 1		CON 2			CON 1		CON 2		
		(dBm)	(W)	(dBm)	(W)		(dBm)	(W)	(dBm)	(W)	
5190.0	6.5M	11.10	0.013	10.99	0.013	< 17	15.17	0.033	16.37	0.043	< 23
5230.0		11.47	0.014	11.36	0.014	< 17	15.54	0.036	16.74	0.047	< 23
5270.0		11.39	0.014	11.26	0.013	< 24	15.46	0.035	16.64	0.046	< 30
5310.0		10.13	0.010	10.00	0.010	< 24	14.20	0.026	15.38	0.035	< 30
5510.0		11.11	0.013	10.98	0.013	< 24	15.18	0.033	16.36	0.043	< 30
5550.0		11.41	0.014	11.28	0.013	< 24	15.48	0.035	16.66	0.046	< 30
5590.0		10.87	0.012	10.74	0.012	< 24	14.94	0.031	16.12	0.041	< 30
5630.0		11.05	0.013	10.92	0.012	< 24	15.12	0.033	16.30	0.043	< 30
5670.0		10.84	0.012	10.71	0.012	< 24	14.91	0.031	16.09	0.041	< 30
5190.0		65M	10.99	0.013	10.91	0.012	< 17	15.06	0.032	16.29	0.043
5230.0	11.36		0.014	11.28	0.013	< 17	15.43	0.035	16.66	0.046	< 30
5270.0	11.26		0.013	11.15	0.013	< 24	15.33	0.034	16.53	0.045	< 30
5310.0	10.00		0.010	9.89	0.010	< 24	14.07	0.026	15.27	0.034	< 30
5510.0	11.00		0.013	10.89	0.012	< 24	15.07	0.032	16.27	0.042	< 30
5550.0	11.30		0.013	11.19	0.013	< 24	15.37	0.034	16.57	0.045	< 30
5590.0	10.76		0.012	10.65	0.012	< 24	14.83	0.030	16.03	0.040	< 30
5630.0	10.94		0.012	10.83	0.012	< 24	15.01	0.032	16.21	0.042	< 30
5670.0	10.73		0.012	10.62	0.012	< 24	14.80	0.030	16.00	0.040	< 30

EIRP = Conducted Average Power + Antenna Gain

## 7 26dB RF Bandwidth Measurement

### 7.1. Limit

N/A

### 7.2. Test Setup

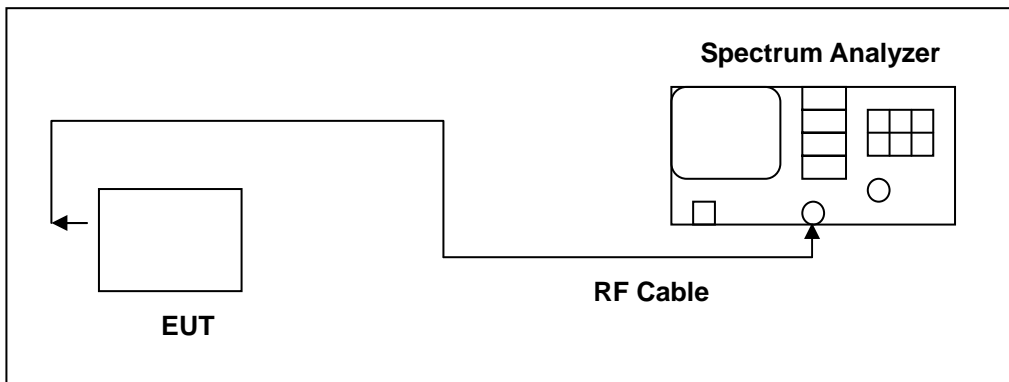

### 7.3. Test Instruments

Equipment	Manufacturer	Model Number	Serial Number	Cal. Date	Remark
Spectrum Analyzer	Agilent	E4445A	MY45300744	12/19/2012	(1)
Test Site	ATL	TE02	TE02	N.C.R.	-----

Remark: (1) Calibration period 1 year. (2) Calibration period 2 years.

NOTE: N.C.R. = No Calibration Request.

### 7.4. Test Procedure

The test is performed in accordance with KDB789033: D01 General UNII Test Procedures v01r03, Guidelines for Compliance Testing of Unlicensed National Information Infrastructure (U-NII) Devices - Part 15, Subpart E.

**7.5. Test Result**

Model Number	PS2 Speaker		
Test Item	26dB RF Bandwidth		
Test Mode	Mode 2: IEEE 802.11a Link Mode		
Date of Test	04/29/2013	Test Site	TE02
	Frequency (MHz)	Measurement (MHz)	
	5180	34.850	
	5220	35.385	
	5240	34.309	
	5260	33.226	
	5280	35.617	
	5320	24.099	
	5500	21.796	
	5580	21.778	
	5700	25.691	

Model Number	PS2 Speaker		
Test Item	26dB RF Bandwidth		
Test Mode	Mode 3: IEEE 802.11n 20MHz Link Mode		
Date of Test	04/29/2013	Test Site	TE02
	Frequency (MHz)	Measurement (MHz)	
	5180	28.797	
	5220	26.893	
	5240	27.602	
	5260	28.434	
	5280	26.316	
	5320	22.749	
	5500	21.208	
	5580	21.125	
	5700	21.211	

Model Number	PS2 Speaker		
Test Item	26dB RF Bandwidth		
Test Mode	Mode 4: IEEE 802.11n 40MHz Link Mode		
Date of Test	04/29/2013	Test Site	TE06
	Frequency (MHz)		Measurement (MHz)
	5190		57.141
	5230		51.491
	5270		42.113
	5310		41.581
	5510		41.521
	5590		41.553
	5670		41.732

7.6. Test Graphs

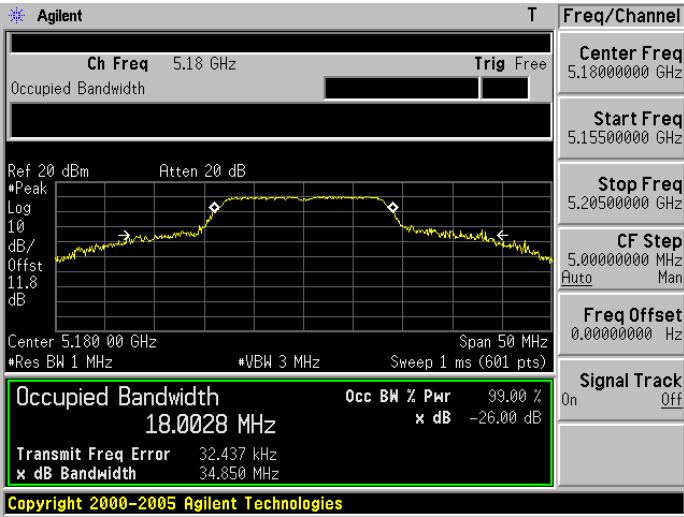
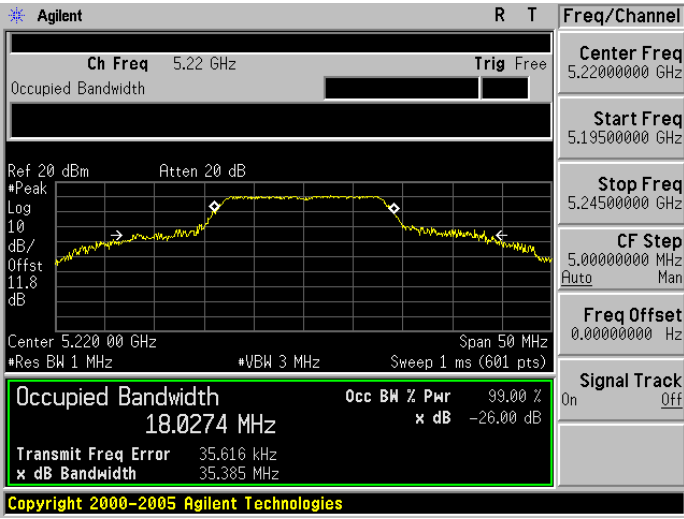
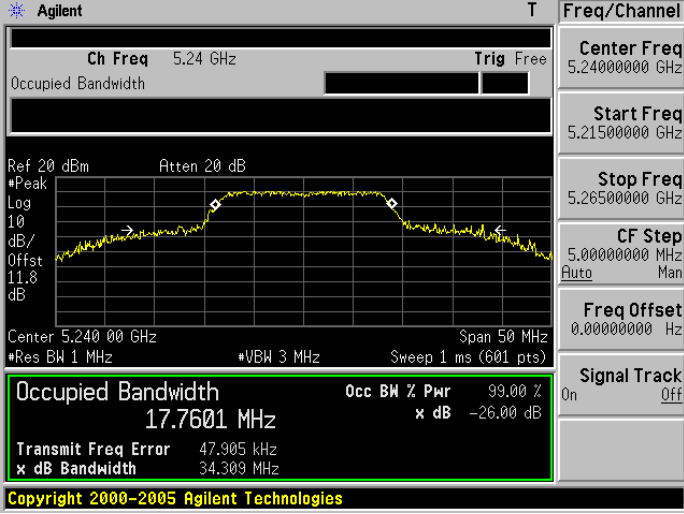
Mode 2: IEEE 802.11a Link Mode	
5180	 <p>Agilent T</p> <p>Ch Freq 5.18 GHz Trig Free</p> <p>Occupied Bandwidth</p> <p>Ref 20 dBm Atten 20 dB</p> <p>#Peak Log 10 dB/Offst 11.8 dB</p> <p>Center 5.180 00 GHz Span 50 MHz</p> <p>#Res BW 1 MHz *VBW 3 MHz Sweep 1 ms (601 pts)</p> <p><b>Occupied Bandwidth 18.0028 MHz</b></p> <p>Occ BN % Pwr 99.00 % x dB -26.00 dB</p> <p>Transmit Freq Error 32.437 kHz x dB Bandwidth 34.850 MHz</p> <p>Copyright 2000-2005 Agilent Technologies</p> <p>Freq/Channel</p> <p>Center Freq 5.18000000 GHz</p> <p>Start Freq 5.15500000 GHz</p> <p>Stop Freq 5.20500000 GHz</p> <p>CF Step 5.00000000 MHz Auto Man</p> <p>Freq Offset 0.00000000 Hz</p> <p>Signal Track On Off</p>
5220	 <p>Agilent R T</p> <p>Ch Freq 5.22 GHz Trig Free</p> <p>Occupied Bandwidth</p> <p>Ref 20 dBm Atten 20 dB</p> <p>#Peak Log 10 dB/Offst 11.8 dB</p> <p>Center 5.220 00 GHz Span 50 MHz</p> <p>#Res BW 1 MHz *VBW 3 MHz Sweep 1 ms (601 pts)</p> <p><b>Occupied Bandwidth 18.0274 MHz</b></p> <p>Occ BN % Pwr 99.00 % x dB -26.00 dB</p> <p>Transmit Freq Error 35.616 kHz x dB Bandwidth 35.385 MHz</p> <p>Copyright 2000-2005 Agilent Technologies</p> <p>Freq/Channel</p> <p>Center Freq 5.22000000 GHz</p> <p>Start Freq 5.19500000 GHz</p> <p>Stop Freq 5.24500000 GHz</p> <p>CF Step 5.00000000 MHz Auto Man</p> <p>Freq Offset 0.00000000 Hz</p> <p>Signal Track On Off</p>
5240	 <p>Agilent T</p> <p>Ch Freq 5.24 GHz Trig Free</p> <p>Occupied Bandwidth</p> <p>Ref 20 dBm Atten 20 dB</p> <p>#Peak Log 10 dB/Offst 11.8 dB</p> <p>Center 5.240 00 GHz Span 50 MHz</p> <p>#Res BW 1 MHz *VBW 3 MHz Sweep 1 ms (601 pts)</p> <p><b>Occupied Bandwidth 17.7601 MHz</b></p> <p>Occ BN % Pwr 99.00 % x dB -26.00 dB</p> <p>Transmit Freq Error 47.905 kHz x dB Bandwidth 34.309 MHz</p> <p>Copyright 2000-2005 Agilent Technologies</p> <p>Freq/Channel</p> <p>Center Freq 5.24000000 GHz</p> <p>Start Freq 5.21500000 GHz</p> <p>Stop Freq 5.26500000 GHz</p> <p>CF Step 5.00000000 MHz Auto Man</p> <p>Freq Offset 0.00000000 Hz</p> <p>Signal Track On Off</p>

Mode 2: IEEE 802.11a Link Mode	
5260	<p>Agilent T Freq/Channel</p> <p>Ch Freq 5.26 GHz Trig Free</p> <p>Center Freq 5.26000000 GHz</p> <p>Start Freq 5.23500000 GHz</p> <p>Stop Freq 5.28500000 GHz</p> <p>CF Step 5.00000000 MHz Auto Man</p> <p>Freq Offset 0.00000000 Hz</p> <p>Signal Track On Off</p> <p>Ref 20 dBm Atten 20 dB</p> <p>#Peak Log 10 dB/Offst 11.8 dB</p> <p>Center 5.260 00 GHz Span 50 MHz</p> <p>#Res BW 1 MHz *VBW 3 MHz Sweep 1 ms (601 pts)</p> <p><b>Occupied Bandwidth 17.9496 MHz</b></p> <p>Occ BW % Pwr 99.00 %</p> <p>x dB -26.00 dB</p> <p>Transmit Freq Error 29.170 kHz</p> <p>x dB Bandwidth 33.226 MHz</p> <p>Copyright 2000-2005 Agilent Technologies</p>
5280	<p>Agilent T Freq/Channel</p> <p>Ch Freq 5.28 GHz Trig Free</p> <p>Center Freq 5.28000000 GHz</p> <p>Start Freq 5.25500000 GHz</p> <p>Stop Freq 5.30500000 GHz</p> <p>CF Step 5.00000000 MHz Auto Man</p> <p>Freq Offset 0.00000000 Hz</p> <p>Signal Track On Off</p> <p>Ref 20 dBm Atten 20 dB</p> <p>#Peak Log 10 dB/Offst 11.8 dB</p> <p>Center 5.280 00 GHz Span 50 MHz</p> <p>#Res BW 1 MHz *VBW 3 MHz Sweep 1 ms (601 pts)</p> <p><b>Occupied Bandwidth 17.8244 MHz</b></p> <p>Occ BW % Pwr 99.00 %</p> <p>x dB -26.00 dB</p> <p>Transmit Freq Error -15.852 kHz</p> <p>x dB Bandwidth 35.617 MHz</p> <p>Copyright 2000-2005 Agilent Technologies</p>
5320	<p>Agilent T Freq/Channel</p> <p>Ch Freq 5.32 GHz Trig Free</p> <p>Center Freq 5.32000000 GHz</p> <p>Start Freq 5.29500000 GHz</p> <p>Stop Freq 5.34500000 GHz</p> <p>CF Step 5.00000000 MHz Auto Man</p> <p>Freq Offset 0.00000000 Hz</p> <p>Signal Track On Off</p> <p>Ref 20 dBm Atten 20 dB</p> <p>#Peak Log 10 dB/Offst 11.8 dB</p> <p>Center 5.320 00 GHz Span 50 MHz</p> <p>#Res BW 1 MHz *VBW 3 MHz Sweep 1 ms (601 pts)</p> <p><b>Occupied Bandwidth 17.4702 MHz</b></p> <p>Occ BW % Pwr 99.00 %</p> <p>x dB -26.00 dB</p> <p>Transmit Freq Error -8.193 kHz</p> <p>x dB Bandwidth 24.099 MHz</p> <p>Copyright 2000-2005 Agilent Technologies</p>

Mode 2: IEEE 802.11a Link Mode	
5500	<p>Agilent T Freq/Channel</p> <p>Ch Freq 5.5 GHz Trig Free</p> <p>Center Freq 5,50000000 GHz</p> <p>Start Freq 5,47500000 GHz</p> <p>Stop Freq 5,52500000 GHz</p> <p>CF Step 5,00000000 MHz Auto Man</p> <p>Freq Offset 0,00000000 Hz</p> <p>Signal Track On Off</p> <p>Ref 20 dBm Atten 20 dB</p> <p>#Peak Log 10 dB/ Offst 11.8 dB</p> <p>Center 5,500 00 GHz Span 50 MHz</p> <p>#Res BW 1 MHz *VBW 3 MHz Sweep 1 ms (601 pts)</p> <p><b>Occupied Bandwidth 17.4969 MHz</b></p> <p>Occ BN % Pwr 99.00 %</p> <p>x dB -26.00 dB</p> <p>Transmit Freq Error 28.553 kHz</p> <p>x dB Bandwidth 21.796 MHz</p> <p>Copyright 2000-2005 Agilent Technologies</p>
5580	<p>Agilent T Freq/Channel</p> <p>Ch Freq 5.58 GHz Trig Free</p> <p>Center Freq 5,58000000 GHz</p> <p>Start Freq 5,55500000 GHz</p> <p>Stop Freq 5,60500000 GHz</p> <p>CF Step 5,00000000 MHz Auto Man</p> <p>Freq Offset 0,00000000 Hz</p> <p>Signal Track On Off</p> <p>Ref 20 dBm Atten 20 dB</p> <p>#Peak Log 10 dB/ Offst 11.8 dB</p> <p>Center 5,580 00 GHz Span 50 MHz</p> <p>#Res BW 1 MHz *VBW 3 MHz Sweep 1 ms (601 pts)</p> <p><b>Occupied Bandwidth 17.5231 MHz</b></p> <p>Occ BN % Pwr 99.00 %</p> <p>x dB -26.00 dB</p> <p>Transmit Freq Error -46.976 kHz</p> <p>x dB Bandwidth 21.778 MHz</p> <p>Copyright 2000-2005 Agilent Technologies</p>
5700	<p>Agilent T Freq/Channel</p> <p>Ch Freq 5.7 GHz Trig Free</p> <p>Center Freq 5,70000000 GHz</p> <p>Start Freq 5,67500000 GHz</p> <p>Stop Freq 5,72500000 GHz</p> <p>CF Step 5,00000000 MHz Auto Man</p> <p>Freq Offset 0,00000000 Hz</p> <p>Signal Track On Off</p> <p>Ref 20 dBm Atten 20 dB</p> <p>#Peak Log 10 dB/ Offst 11.8 dB</p> <p>Center 5,700 00 GHz Span 50 MHz</p> <p>#Res BW 1 MHz *VBW 3 MHz Sweep 1 ms (601 pts)</p> <p><b>Occupied Bandwidth 17.6168 MHz</b></p> <p>Occ BN % Pwr 99.00 %</p> <p>x dB -26.00 dB</p> <p>Transmit Freq Error -47.631 kHz</p> <p>x dB Bandwidth 25.691 MHz</p> <p>Copyright 2000-2005 Agilent Technologies</p>

Mode 3: IEEE 802.11n 20MHz Link Mode	
5180	<p><b>Agilent</b> T</p> <p>Ch Freq 5.18 GHz Trig Free</p> <p>Occupied Bandwidth</p> <p>Ref 20 dBm Atten 20 dB</p> <p>#Peak Log 10 dB/Offst 11.8 dB</p> <p>Center 5.180 00 GHz Span 50 MHz</p> <p>#Res BW 1 MHz *VBW 3 MHz Sweep 1 ms (601 pts)</p> <p><b>Occupied Bandwidth</b> 18.3619 MHz</p> <p>Occ BW % Pwr 99.00 %</p> <p>x dB -26.00 dB</p> <p>Transmit Freq Error 62.442 kHz</p> <p>x dB Bandwidth 28.797 MHz</p> <p>Copyright 2000-2005 Agilent Technologies</p> <p><b>Freq/Channel</b></p> <p>Center Freq 5.18000000 GHz</p> <p>Start Freq 5.15500000 GHz</p> <p>Stop Freq 5.20500000 GHz</p> <p>CF Step 5.00000000 MHz</p> <p>Auto Man</p> <p>Freq Offset 0.00000000 Hz</p> <p>Signal Track On Off</p>
5220	<p><b>Agilent</b> T</p> <p>Ch Freq 5.22 GHz Trig Free</p> <p>Occupied Bandwidth</p> <p>Ref 20 dBm Atten 20 dB</p> <p>#Peak Log 10 dB/Offst 11.8 dB</p> <p>Center 5.220 00 GHz Span 50 MHz</p> <p>#Res BW 1 MHz *VBW 3 MHz Sweep 1 ms (601 pts)</p> <p><b>Occupied Bandwidth</b> 18.3974 MHz</p> <p>Occ BW % Pwr 99.00 %</p> <p>x dB -26.00 dB</p> <p>Transmit Freq Error 9.231 kHz</p> <p>x dB Bandwidth 26.893 MHz</p> <p>Copyright 2000-2005 Agilent Technologies</p> <p><b>Freq/Channel</b></p> <p>Center Freq 5.22000000 GHz</p> <p>Start Freq 5.19500000 GHz</p> <p>Stop Freq 5.24500000 GHz</p> <p>CF Step 5.00000000 MHz</p> <p>Auto Man</p> <p>Freq Offset 0.00000000 Hz</p> <p>Signal Track On Off</p>
5240	<p><b>Agilent</b> T</p> <p>Ch Freq 5.24 GHz Trig Free</p> <p>Occupied Bandwidth</p> <p>Ref 20 dBm Atten 20 dB</p> <p>#Peak Log 10 dB/Offst 11.8 dB</p> <p>Center 5.240 00 GHz Span 50 MHz</p> <p>#Res BW 1 MHz *VBW 3 MHz Sweep 1 ms (601 pts)</p> <p><b>Occupied Bandwidth</b> 18.4393 MHz</p> <p>Occ BW % Pwr 99.00 %</p> <p>x dB -26.00 dB</p> <p>Transmit Freq Error 37.680 kHz</p> <p>x dB Bandwidth 27.602 MHz</p> <p>Copyright 2000-2005 Agilent Technologies</p> <p><b>Freq/Channel</b></p> <p>Center Freq 5.24000000 GHz</p> <p>Start Freq 5.21500000 GHz</p> <p>Stop Freq 5.26500000 GHz</p> <p>CF Step 5.00000000 MHz</p> <p>Auto Man</p> <p>Freq Offset 0.00000000 Hz</p> <p>Signal Track On Off</p>



Mode 3: IEEE 802.11n 20MHz Link Mode	
5260	<p><b>Agilent</b> T</p> <p>Ch Freq 5.26 GHz Trig Free</p> <p>Occupied Bandwidth</p> <p>Ref 20 dBm Atten 20 dB</p> <p>#Peak 10 dB/Offst 11.8 dB</p> <p>Center 5.260 00 GHz Span 50 MHz</p> <p>#Res BW 1 MHz *VBW 3 MHz Sweep 1 ms (601 pts)</p> <p><b>Occupied Bandwidth</b> 18.3908 MHz</p> <p>Occ BW % Pwr 99.00 % x dB -26.00 dB</p> <p>Transmit Freq Error 14.275 kHz x dB Bandwidth 28.434 MHz</p> <p>Copyright 2000-2005 Agilent Technologies</p> <p>Freq/Channel</p> <p>Center Freq 5.26000000 GHz</p> <p>Start Freq 5.23500000 GHz</p> <p>Stop Freq 5.28500000 GHz</p> <p>CF Step 5.00000000 MHz Auto Man</p> <p>Freq Offset 0.00000000 Hz</p> <p>Signal Track On Off</p>
5280	<p><b>Agilent</b> T</p> <p>Ch Freq 5.28 GHz Trig Free</p> <p>Occupied Bandwidth</p> <p>Ref 20 dBm Atten 20 dB</p> <p>#Peak 10 dB/Offst 11.8 dB</p> <p>Center 5.280 00 GHz Span 50 MHz</p> <p>#Res BW 1 MHz *VBW 3 MHz Sweep 1 ms (601 pts)</p> <p><b>Occupied Bandwidth</b> 18.4337 MHz</p> <p>Occ BW % Pwr 99.00 % x dB -26.00 dB</p> <p>Transmit Freq Error -41.124 kHz x dB Bandwidth 26.316 MHz</p> <p>Copyright 2000-2005 Agilent Technologies</p> <p>Freq/Channel</p> <p>Center Freq 5.28000000 GHz</p> <p>Start Freq 5.25500000 GHz</p> <p>Stop Freq 5.30500000 GHz</p> <p>CF Step 5.00000000 MHz Auto Man</p> <p>Freq Offset 0.00000000 Hz</p> <p>Signal Track On Off</p>
5320	<p><b>Agilent</b> T</p> <p>Ch Freq 5.32 GHz Trig Free</p> <p>Occupied Bandwidth</p> <p>Ref 20 dBm Atten 20 dB</p> <p>#Peak 10 dB/Offst 11.8 dB</p> <p>Center 5.320 00 GHz Span 50 MHz</p> <p>#Res BW 1 MHz *VBW 3 MHz Sweep 1 ms (601 pts)</p> <p><b>Occupied Bandwidth</b> 17.5638 MHz</p> <p>Occ BW % Pwr 99.00 % x dB -26.00 dB</p> <p>Transmit Freq Error -38.150 kHz x dB Bandwidth 22.749 MHz</p> <p>Copyright 2000-2005 Agilent Technologies</p> <p>Freq/Channel</p> <p>Center Freq 5.32000000 GHz</p> <p>Start Freq 5.29500000 GHz</p> <p>Stop Freq 5.34500000 GHz</p> <p>CF Step 5.00000000 MHz Auto Man</p> <p>Freq Offset 0.00000000 Hz</p> <p>Signal Track On Off</p>

Mode 3: IEEE 802.11n 20MHz Link Mode	
5500	<p><b>Agilent</b> T Freq/Channel</p> <p>Ch Freq 5.5 GHz Trig Free</p> <p>Center Freq 5,50000000 GHz</p> <p>Start Freq 5,47500000 GHz</p> <p>Stop Freq 5,52500000 GHz</p> <p>CF Step 5,00000000 MHz Auto Man</p> <p>Freq Offset 0,00000000 Hz</p> <p>Signal Track On Off</p> <p>Ref 20 dBm Atten 20 dB</p> <p>#Peak Log 10 dB/Offst 11.8 dB</p> <p>Center 5,500 00 GHz Span 50 MHz</p> <p>#Res BW 1 MHz *VBW 3 MHz Sweep 1 ms (601 pts)</p> <p><b>Occupied Bandwidth 18.2510 MHz</b></p> <p>Occ BW % Pwr 99.00 %</p> <p>x dB -26.00 dB</p> <p>Transmit Freq Error 10.143 kHz</p> <p>x dB Bandwidth 21.208 MHz</p> <p>Copyright 2000-2005 Agilent Technologies</p>
5580	<p><b>Agilent</b> T Freq/Channel</p> <p>Ch Freq 5.58 GHz Trig Free</p> <p>Center Freq 5,58000000 GHz</p> <p>Start Freq 5,55500000 GHz</p> <p>Stop Freq 5,60500000 GHz</p> <p>CF Step 5,00000000 MHz Auto Man</p> <p>Freq Offset 0,00000000 Hz</p> <p>Signal Track On Off</p> <p>Ref 20 dBm Atten 20 dB</p> <p>#Peak Log 10 dB/Offst 11.8 dB</p> <p>Center 5,580 00 GHz Span 50 MHz</p> <p>#Res BW 1 MHz *VBW 3 MHz Sweep 1 ms (601 pts)</p> <p><b>Occupied Bandwidth 18.2944 MHz</b></p> <p>Occ BW % Pwr 99.00 %</p> <p>x dB -26.00 dB</p> <p>Transmit Freq Error -35.407 kHz</p> <p>x dB Bandwidth 21.125 MHz</p> <p>Copyright 2000-2005 Agilent Technologies</p>
5700	<p><b>Agilent</b> T Freq/Channel</p> <p>Ch Freq 5.7 GHz Trig Free</p> <p>Center Freq 5,70000000 GHz</p> <p>Start Freq 5,67500000 GHz</p> <p>Stop Freq 5,72500000 GHz</p> <p>CF Step 5,00000000 MHz Auto Man</p> <p>Freq Offset 0,00000000 Hz</p> <p>Signal Track On Off</p> <p>Ref 20 dBm Atten 20 dB</p> <p>#Peak Log 10 dB/Offst 11.8 dB</p> <p>Center 5,700 00 GHz Span 50 MHz</p> <p>#Res BW 1 MHz *VBW 3 MHz Sweep 1 ms (601 pts)</p> <p><b>Occupied Bandwidth 18.3292 MHz</b></p> <p>Occ BW % Pwr 99.00 %</p> <p>x dB -26.00 dB</p> <p>Transmit Freq Error -34.740 kHz</p> <p>x dB Bandwidth 21.211 MHz</p> <p>Copyright 2000-2005 Agilent Technologies</p>

Mode 4: IEEE 802.11n 40MHz Link Mode

<p>5190</p>	<p>Agilent T</p> <p>Ch Freq 5.19 GHz Trig Free</p> <p>Occupied Bandwidth</p> <p>Ref 20 dBm Atten 20 dB</p> <p>#Peak 10</p> <p>Log dB/Offst 11.8 dB</p> <p>Center 5.190 0 GHz Span 100 MHz</p> <p>#Res BW 1 MHz *VBW 3 MHz Sweep 1 ms (601 pts)</p> <p><b>Occupied Bandwidth 36.9100 MHz</b></p> <p>Occ BN % Pwr 99.00 %</p> <p>x dB -26.00 dB</p> <p>Transmit Freq Error 101.662 kHz</p> <p>x dB Bandwidth 57.141 MHz</p> <p>Copyright 2000-2005 Agilent Technologies</p> <p>Freq/Channel</p> <p>Center Freq 5.19000000 GHz</p> <p>Start Freq 5.14000000 GHz</p> <p>Stop Freq 5.24000000 GHz</p> <p>CF Step 10.0000000 MHz</p> <p>Auto Man</p> <p>Freq Offset 0.00000000 Hz</p> <p>Signal Track On Off</p>
<p>5230</p>	<p>Agilent R T</p> <p>Ch Freq 5.23 GHz Trig Free</p> <p>Occupied Bandwidth</p> <p>Ref 20 dBm Atten 20 dB</p> <p>#Peak 10</p> <p>Log dB/Offst 11.8 dB</p> <p>Center 5.230 0 GHz Span 100 MHz</p> <p>#Res BW 1 MHz *VBW 3 MHz Sweep 1 ms (601 pts)</p> <p><b>Occupied Bandwidth 36.9699 MHz</b></p> <p>Occ BN % Pwr 99.00 %</p> <p>x dB -26.00 dB</p> <p>Transmit Freq Error 142.258 kHz</p> <p>x dB Bandwidth 51.491 MHz</p> <p>Copyright 2000-2005 Agilent Technologies</p> <p>Freq/Channel</p> <p>Center Freq 5.23000000 GHz</p> <p>Start Freq 5.18000000 GHz</p> <p>Stop Freq 5.28000000 GHz</p> <p>CF Step 10.0000000 MHz</p> <p>Auto Man</p> <p>Freq Offset 0.00000000 Hz</p> <p>Signal Track On Off</p>

Mode 4: IEEE 802.11n 40MHz Link Mode

5270	<p>Agilent T Freq/Channel</p> <p>Ch Freq 5.27 GHz Trig Free</p> <p>Center Freq 5.27000000 GHz</p> <p>Start Freq 5.22000000 GHz</p> <p>Stop Freq 5.32000000 GHz</p> <p>CF Step 10.00000000 MHz Auto Man</p> <p>Freq Offset 0.00000000 Hz</p> <p>Signal Track On Off</p> <p>Ref 20 dBm Atten 20 dB</p> <p>#Peak Log 10 dB/ Offst 11.8 dB</p> <p>Center 5.270 0 GHz Span 100 MHz</p> <p>#Res BW 1 MHz *VBW 3 MHz Sweep 1 ms (601 pts)</p> <p><b>Occupied Bandwidth 36.7956 MHz</b></p> <p>Occ BW % Pwr 99.00 %</p> <p>x dB -26.00 dB</p> <p>Transmit Freq Error -46.910 kHz</p> <p>x dB Bandwidth 42.113 MHz</p> <p>Copyright 2000-2005 Agilent Technologies</p>
5310	<p>Agilent T Freq/Channel</p> <p>Ch Freq 5.31 GHz Trig Free</p> <p>Center Freq 5.31000000 GHz</p> <p>Start Freq 5.26000000 GHz</p> <p>Stop Freq 5.36000000 GHz</p> <p>CF Step 10.00000000 MHz Auto Man</p> <p>Freq Offset 0.00000000 Hz</p> <p>Signal Track On Off</p> <p>Ref 20 dBm Atten 20 dB</p> <p>#Peak Log 10 dB/ Offst 11.8 dB</p> <p>Center 5.310 0 GHz Span 100 MHz</p> <p>#Res BW 1 MHz *VBW 3 MHz Sweep 1 ms (601 pts)</p> <p><b>Occupied Bandwidth 36.8418 MHz</b></p> <p>Occ BW % Pwr 99.00 %</p> <p>x dB -26.00 dB</p> <p>Transmit Freq Error 31.746 kHz</p> <p>x dB Bandwidth 41.581 MHz</p> <p>Copyright 2000-2005 Agilent Technologies</p>

Mode 4: IEEE 802.11n 40MHz Link Mode	
5510	<p>Agilent T Freq/Channel</p> <p>Ch Freq 5.51 GHz Trig Free</p> <p>Center Freq 5,51000000 GHz</p> <p>Start Freq 5,46000000 GHz</p> <p>Stop Freq 5,56000000 GHz</p> <p>CF Step 10,0000000 MHz Auto Man</p> <p>Freq Offset 0,00000000 Hz</p> <p>Signal Track On Off</p> <p>Occupied Bandwidth 36.8736 MHz Occ BW % Pwr 99.00 % x dB -26.00 dB</p> <p>Transmit Freq Error 94.494 kHz x dB Bandwidth 41.521 MHz</p> <p>Copyright 2000-2005 Agilent Technologies</p>
5590	<p>Agilent T Freq/Channel</p> <p>Ch Freq 5.59 GHz Trig Free</p> <p>Center Freq 5,59000000 GHz</p> <p>Start Freq 5,54000000 GHz</p> <p>Stop Freq 5,64000000 GHz</p> <p>CF Step 10,0000000 MHz Auto Man</p> <p>Freq Offset 0,00000000 Hz</p> <p>Signal Track On Off</p> <p>Occupied Bandwidth 36.7884 MHz Occ BW % Pwr 99.00 % x dB -26.00 dB</p> <p>Transmit Freq Error 4,014 kHz x dB Bandwidth 41.553 MHz</p> <p>Copyright 2000-2005 Agilent Technologies</p>
5670	<p>Agilent T Freq/Channel</p> <p>Ch Freq 5.67 GHz Trig Free</p> <p>Center Freq 5,67000000 GHz</p> <p>Start Freq 5,62000000 GHz</p> <p>Stop Freq 5,72000000 GHz</p> <p>CF Step 10,0000000 MHz Auto Man</p> <p>Freq Offset 0,00000000 Hz</p> <p>Signal Track On Off</p> <p>Occupied Bandwidth 36.7393 MHz Occ BW % Pwr 99.00 % x dB -26.00 dB</p> <p>Transmit Freq Error -15,449 kHz x dB Bandwidth 41.732 MHz</p> <p>Copyright 2000-2005 Agilent Technologies</p>

## 8 Peak Power Excursion Measurement

### 8.1. Limit

Frequency Range (MHz)	Limit
5.150 ~ 5.250 GHz	13 dB
5.250 ~ 5.350 GHz	13 dB
5.470 ~ 5.725 GHz	13 dB

### 8.2. Test Setup

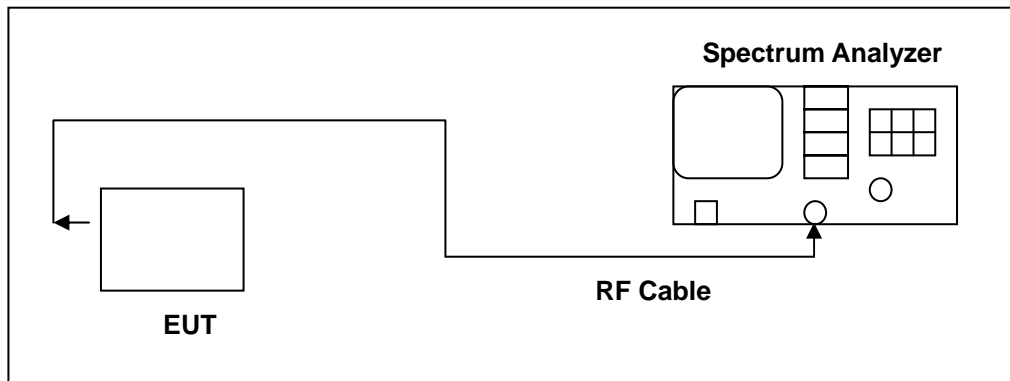

### 8.3. Test Instruments

Equipment	Manufacturer	Model Number	Serial Number	Cal. Date	Remark
Spectrum Analyzer	Agilent	E4445A	MY45300744	12/19/2012	(1)
Test Site	ATL	TE02	TE02	N.C.R.	-----

Remark: (1) Calibration period 1 year. (2) Calibration period 2 years.

NOTE: N.C.R. = No Calibration Request.

### 8.4. Test Procedure

The test is performed in accordance with KDB789033: D01 General UNII Test Procedures v01r03, Guidelines for Compliance Testing of Unlicensed National Information Infrastructure (U-NII) Devices - Part 15, Subpart E.

**8.5. Test Result**

Model Number	PS2 Speaker		
Test Item	Peak Power Excursion		
Test Mode	Mode 2: IEEE 802.11a Link Mode		
Date of Test	04/29/2013	Test Site	TE02
Frequency (MHz)	Measurement (dB)	Limit (dB)	
5180	-7.190	< 13	
5220	-8.011	< 13	
5240	-8.061	< 13	
5260	-8.275	< 13	
5280	-7.925	< 13	
5320	-7.692	< 13	
5500	-7.722	< 13	
5580	-7.875	< 13	
5700	-7.741	< 13	

Model Number	PS2 Speaker		
Test Item	Peak Power Excursion		
Test Mode	Mode 3: IEEE 802.11n 20MHz Link Mode		
Date of Test	04/29/2013	Test Site	TE02
Frequency (MHz)	Measurement (dB)	Limit (dB)	
5180	-8.069	< 13	
5220	-7.897	< 13	
5240	-7.743	< 13	
5260	-7.813	< 13	
5280	-8.267	< 13	
5320	-7.795	< 13	
5500	-7.766	< 13	
5580	-8.128	< 13	
5700	-8.207	< 13	

Model Number	PS2 Speaker		
Test Item	Peak Power Excursion		
Test Mode	Mode 4: IEEE 802.11n 40MHz Link Mode		
Date of Test	04/29/2013	Test Site	TE06
Frequency (MHz)	Measurement (dB)	Limit (dB)	
5190	-7.876	< 13	
5230	-8.021	< 13	
5270	-8.023	< 13	
5310	-8.104	< 13	
5510	-8.089	< 13	
5590	-7.920	< 13	
5670	-8.113	< 13	

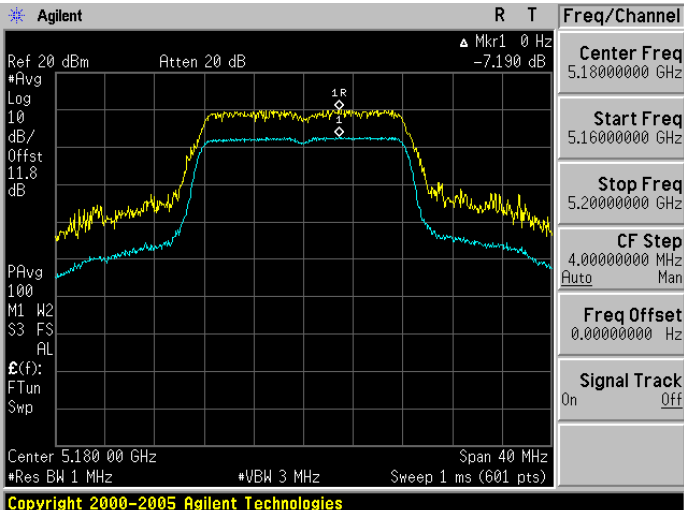
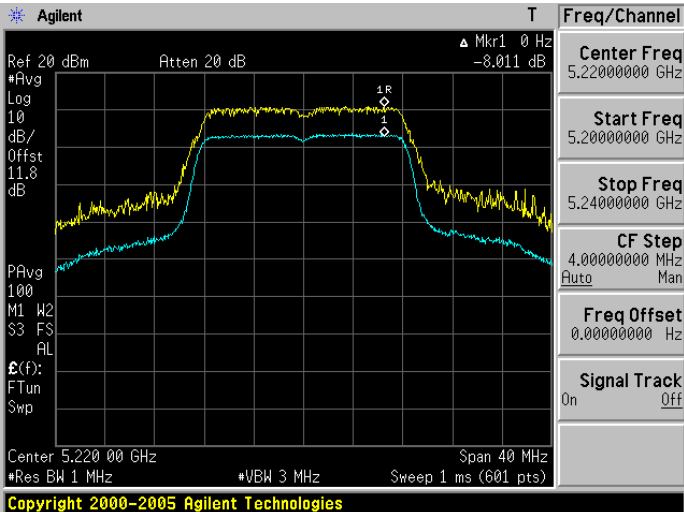
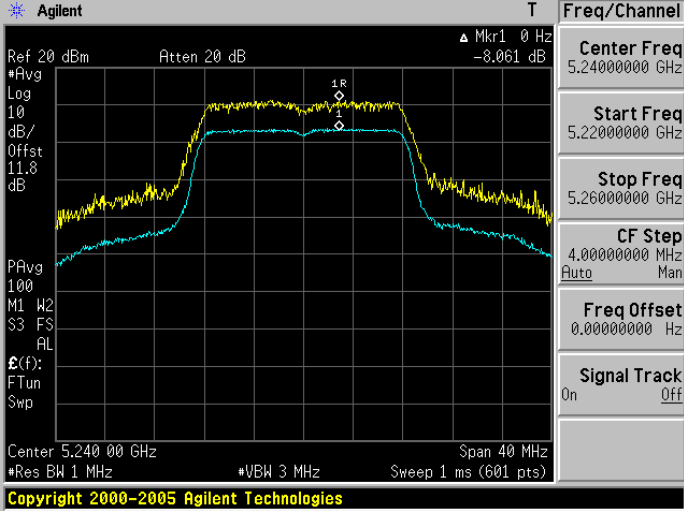

8.6. Test Graphs

Mode 2: IEEE 802.11a Link Mode	
5180	 <p>Copyright 2000-2005 Agilent Technologies</p>
5220	 <p>Copyright 2000-2005 Agilent Technologies</p>
5240	 <p>Copyright 2000-2005 Agilent Technologies</p>

Mode 2: IEEE 802.11a Link Mode	
5260	<p>Agilent T Freq/Channel</p> <p>Ref 20 dBm Atten 20 dB Δ Mkr1 0 Hz -8.275 dB</p> <p>#Avg Log 10 dB/Offst 11.8 dB</p> <p>PAvg 100 M1 W2 S3 FS AL</p> <p>Ⓔ(f): FTun Swp</p> <p>Center 5.260 00 GHz Span 40 MHz #Res BN 1 MHz *VBW 3 MHz Sweep 1 ms (601 pts)</p> <p>Copyright 2000-2005 Agilent Technologies</p> <p>Center Freq 5.26000000 GHz</p> <p>Start Freq 5.24000000 GHz</p> <p>Stop Freq 5.28000000 GHz</p> <p>CF Step 4.00000000 MHz Auto Man</p> <p>Freq Offset 0.00000000 Hz</p> <p>Signal Track On Off</p>
5280	<p>Agilent T Freq/Channel</p> <p>Ref 20 dBm Atten 20 dB Δ Mkr1 0 Hz -7.925 dB</p> <p>#Avg Log 10 dB/Offst 11.8 dB</p> <p>PAvg 100 M1 W2 S3 FS AL</p> <p>Ⓔ(f): FTun Swp</p> <p>Center 5.280 00 GHz Span 40 MHz #Res BN 1 MHz *VBW 3 MHz Sweep 1 ms (601 pts)</p> <p>Copyright 2000-2005 Agilent Technologies</p> <p>Center Freq 5.28000000 GHz</p> <p>Start Freq 5.26000000 GHz</p> <p>Stop Freq 5.30000000 GHz</p> <p>CF Step 4.00000000 MHz Auto Man</p> <p>Freq Offset 0.00000000 Hz</p> <p>Signal Track On Off</p>
5320	<p>Agilent T Freq/Channel</p> <p>Ref 20 dBm Atten 20 dB Δ Mkr1 0 Hz -7.692 dB</p> <p>#Avg Log 10 dB/Offst 11.8 dB</p> <p>PAvg 100 M1 W2 S3 FS AL</p> <p>Ⓔ(f): FTun Swp</p> <p>Center 5.320 00 GHz Span 40 MHz #Res BN 1 MHz *VBW 3 MHz Sweep 1 ms (601 pts)</p> <p>Copyright 2000-2005 Agilent Technologies</p> <p>Center Freq 5.32000000 GHz</p> <p>Start Freq 5.30000000 GHz</p> <p>Stop Freq 5.34000000 GHz</p> <p>CF Step 4.00000000 MHz Auto Man</p> <p>Freq Offset 0.00000000 Hz</p> <p>Signal Track On Off</p>

Mode 2: IEEE 802.11a Link Mode	
5500	<p>Agilent T Freq/Channel</p> <p>Ref 20 dBm Atten 20 dB <math>\Delta</math> Mkr1 0 Hz -7.722 dB</p> <p>#Avg Log 10 dB/Offst 11.8 dB</p> <p>PAvg 100 M1 W2 S3 FS AL <math>\mathcal{E}(f)</math>: FTun Swp</p> <p>Center 5.500 00 GHz Span 28 MHz #Res BW 1 MHz *VBW 3 MHz Sweep 1 ms (601 pts)</p> <p>Copyright 2000-2005 Agilent Technologies</p> <p>Center Freq: 5,50000000 GHz Start Freq: 5,48600000 GHz Stop Freq: 5,51400000 GHz CF Step: 2,80000000 MHz (Auto/Man) Freq Offset: 0,00000000 Hz Signal Track: On/Off</p>
5580	<p>Agilent T Freq/Channel</p> <p>Ref 20 dBm Atten 20 dB <math>\Delta</math> Mkr1 0 Hz -7.875 dB</p> <p>#Avg Log 10 dB/Offst 11.8 dB</p> <p>PAvg 100 M1 W2 S3 FS AL <math>\mathcal{E}(f)</math>: FTun Swp</p> <p>Center 5.580 00 GHz Span 28 MHz #Res BW 1 MHz *VBW 3 MHz Sweep 1 ms (601 pts)</p> <p>Copyright 2000-2005 Agilent Technologies</p> <p>Center Freq: 5,58000000 GHz Start Freq: 5,56600000 GHz Stop Freq: 5,59400000 GHz CF Step: 2,80000000 MHz (Auto/Man) Freq Offset: 0,00000000 Hz Signal Track: On/Off</p>
5700	<p>Agilent T Freq/Channel</p> <p>Ref 20 dBm Atten 20 dB <math>\Delta</math> Mkr1 0 Hz -7.741 dB</p> <p>#Avg Log 10 dB/Offst 11.8 dB</p> <p>PAvg 100 M1 W2 S3 FS AL <math>\mathcal{E}(f)</math>: FTun Swp</p> <p>Center 5.700 00 GHz Span 28 MHz #Res BW 1 MHz *VBW 3 MHz Sweep 1 ms (601 pts)</p> <p>Copyright 2000-2005 Agilent Technologies</p> <p>Center Freq: 5,70000000 GHz Start Freq: 5,68600000 GHz Stop Freq: 5,71400000 GHz CF Step: 2,80000000 MHz (Auto/Man) Freq Offset: 0,00000000 Hz Signal Track: On/Off</p>

Mode 3: IEEE 802.11n 20MHz Link Mode	
5180	<p>Agilent T Freq/Channel</p> <p>Ref 20 dBm Atten 20 dB Δ Mkr1 0 Hz -8.069 dB</p> <p>Center Freq 5.1800000 GHz</p> <p>Start Freq 5.16450000 GHz</p> <p>Stop Freq 5.19550000 GHz</p> <p>CF Step 3.10000000 MHz Auto Man</p> <p>Freq Offset 0.00000000 Hz</p> <p>Signal Track On Off</p> <p>Center 5.180 00 GHz Span 31 MHz</p> <p>#Res BW 1 MHz *VBW 3 MHz Sweep 1 ms (601 pts)</p> <p>Copyright 2000-2005 Agilent Technologies</p>
5220	<p>Agilent T Freq/Channel</p> <p>Ref 20 dBm Atten 20 dB Δ Mkr1 0 Hz -7.837 dB</p> <p>Center Freq 5.2200000 GHz</p> <p>Start Freq 5.20450000 GHz</p> <p>Stop Freq 5.23550000 GHz</p> <p>CF Step 3.10000000 MHz Auto Man</p> <p>Freq Offset 0.00000000 Hz</p> <p>Signal Track On Off</p> <p>Center 5.220 00 GHz Span 31 MHz</p> <p>#Res BW 1 MHz *VBW 3 MHz Sweep 1 ms (601 pts)</p> <p>Copyright 2000-2005 Agilent Technologies</p>
5240	<p>Agilent T Freq/Channel</p> <p>Ref 20 dBm Atten 20 dB Δ Mkr1 0 Hz -7.743 dB</p> <p>Center Freq 5.2400000 GHz</p> <p>Start Freq 5.22450000 GHz</p> <p>Stop Freq 5.25550000 GHz</p> <p>CF Step 3.10000000 MHz Auto Man</p> <p>Freq Offset 0.00000000 Hz</p> <p>Signal Track On Off</p> <p>Center 5.240 00 GHz Span 31 MHz</p> <p>#Res BW 1 MHz *VBW 3 MHz Sweep 1 ms (601 pts)</p> <p>Copyright 2000-2005 Agilent Technologies</p>

Mode 3: IEEE 802.11n 20MHz Link Mode															
5260	<p>Copyright 2000-2005 Agilent Technologies</p> <table border="1"> <thead> <tr> <th colspan="2">Freq/Channel</th> </tr> </thead> <tbody> <tr> <td>Center Freq</td> <td>5.26000000 GHz</td> </tr> <tr> <td>Start Freq</td> <td>5.24450000 GHz</td> </tr> <tr> <td>Stop Freq</td> <td>5.27550000 GHz</td> </tr> <tr> <td>CF Step</td> <td>3.10000000 MHz Auto Man</td> </tr> <tr> <td>Freq Offset</td> <td>0.00000000 Hz</td> </tr> <tr> <td>Signal Track</td> <td>On Off</td> </tr> </tbody> </table>	Freq/Channel		Center Freq	5.26000000 GHz	Start Freq	5.24450000 GHz	Stop Freq	5.27550000 GHz	CF Step	3.10000000 MHz Auto Man	Freq Offset	0.00000000 Hz	Signal Track	On Off
Freq/Channel															
Center Freq	5.26000000 GHz														
Start Freq	5.24450000 GHz														
Stop Freq	5.27550000 GHz														
CF Step	3.10000000 MHz Auto Man														
Freq Offset	0.00000000 Hz														
Signal Track	On Off														
5280	<p>Copyright 2000-2005 Agilent Technologies</p> <table border="1"> <thead> <tr> <th colspan="2">Freq/Channel</th> </tr> </thead> <tbody> <tr> <td>Center Freq</td> <td>5.28000000 GHz</td> </tr> <tr> <td>Start Freq</td> <td>5.26450000 GHz</td> </tr> <tr> <td>Stop Freq</td> <td>5.29550000 GHz</td> </tr> <tr> <td>CF Step</td> <td>3.10000000 MHz Auto Man</td> </tr> <tr> <td>Freq Offset</td> <td>0.00000000 Hz</td> </tr> <tr> <td>Signal Track</td> <td>On Off</td> </tr> </tbody> </table>	Freq/Channel		Center Freq	5.28000000 GHz	Start Freq	5.26450000 GHz	Stop Freq	5.29550000 GHz	CF Step	3.10000000 MHz Auto Man	Freq Offset	0.00000000 Hz	Signal Track	On Off
Freq/Channel															
Center Freq	5.28000000 GHz														
Start Freq	5.26450000 GHz														
Stop Freq	5.29550000 GHz														
CF Step	3.10000000 MHz Auto Man														
Freq Offset	0.00000000 Hz														
Signal Track	On Off														
5320	<p>Copyright 2000-2005 Agilent Technologies</p> <table border="1"> <thead> <tr> <th colspan="2">Freq/Channel</th> </tr> </thead> <tbody> <tr> <td>Center Freq</td> <td>5.32000000 GHz</td> </tr> <tr> <td>Start Freq</td> <td>5.30450000 GHz</td> </tr> <tr> <td>Stop Freq</td> <td>5.33550000 GHz</td> </tr> <tr> <td>CF Step</td> <td>3.10000000 MHz Auto Man</td> </tr> <tr> <td>Freq Offset</td> <td>0.00000000 Hz</td> </tr> <tr> <td>Signal Track</td> <td>On Off</td> </tr> </tbody> </table>	Freq/Channel		Center Freq	5.32000000 GHz	Start Freq	5.30450000 GHz	Stop Freq	5.33550000 GHz	CF Step	3.10000000 MHz Auto Man	Freq Offset	0.00000000 Hz	Signal Track	On Off
Freq/Channel															
Center Freq	5.32000000 GHz														
Start Freq	5.30450000 GHz														
Stop Freq	5.33550000 GHz														
CF Step	3.10000000 MHz Auto Man														
Freq Offset	0.00000000 Hz														
Signal Track	On Off														

Mode 3: IEEE 802.11n 20MHz Link Mode

5500	
5580	
5700	

Mode 4: IEEE 802.11n 40MHz Link Mode

5190	<p>Agilent T Freq/Channel</p> <p>Ref 20 dBm Atten 20 dB Δ Mkr1 0 Hz -7.876 dB</p> <p>#Avg Log 10 dB/Offst 11.8 dB</p> <p>PAvg 100 M1 W2 S3 FS AL</p> <p>Center 5.190 00 GHz Span 60 MHz</p> <p>#Res BW 1 MHz *VBW 3 MHz Sweep 1 ms (601 pts)</p> <p>Copyright 2000-2005 Agilent Technologies</p> <p>Center Freq: 5.19000000 GHz</p> <p>Start Freq: 5.16000000 GHz</p> <p>Stop Freq: 5.22000000 GHz</p> <p>CF Step: 6.00000000 MHz (Auto/Man)</p> <p>Freq Offset: 0.00000000 Hz</p> <p>Signal Track: On (Off)</p>
5230	<p>Agilent T Freq/Channel</p> <p>Ref 20 dBm Atten 20 dB Δ Mkr1 0 Hz -8.021 dB</p> <p>#Avg Log 10 dB/Offst 11.8 dB</p> <p>PAvg 100 M1 W2 S3 FS AL</p> <p>Center 5.230 00 GHz Span 60 MHz</p> <p>#Res BW 1 MHz *VBW 3 MHz Sweep 1 ms (601 pts)</p> <p>Copyright 2000-2005 Agilent Technologies</p> <p>Center Freq: 5.23000000 GHz</p> <p>Start Freq: 5.20000000 GHz</p> <p>Stop Freq: 5.26000000 GHz</p> <p>CF Step: 6.00000000 MHz (Auto/Man)</p> <p>Freq Offset: 0.00000000 Hz</p> <p>Signal Track: On (Off)</p>

Mode 4: IEEE 802.11n 40MHz Link Mode

5270	<p>Agilent T Freq/Channel</p> <p>Ref 20 dBm Atten 20 dB Δ Mkr1 0 Hz -8.023 dB</p> <p>#Avg Log 10 dB/ Offst 11.8 dB</p> <p>PAvg 100 M1 W2 S3 FS AL</p> <p>Ⓔ(f): FTun Swp</p> <p>Center 5.270 00 GHz Span 45 MHz #Res BW 1 MHz *VBW 3 MHz Sweep 1 ms (601 pts)</p> <p>Copyright 2000-2005 Agilent Technologies</p> <p>Center Freq: 5.2700000 GHz Start Freq: 5.2475000 GHz Stop Freq: 5.2925000 GHz CF Step: 4.5000000 MHz (Auto/Man) Freq Offset: 0.0000000 Hz Signal Track: On/Off</p>
5310	<p>Agilent T Freq/Channel</p> <p>Ref 20 dBm Atten 20 dB Δ Mkr1 0 Hz -8.104 dB</p> <p>#Avg Log 10 dB/ Offst 11.8 dB</p> <p>PAvg 100 M1 W2 S3 FS AL</p> <p>Ⓔ(f): FTun Swp</p> <p>Center 5.310 00 GHz Span 45 MHz #Res BW 1 MHz *VBW 3 MHz Sweep 1 ms (601 pts)</p> <p>Copyright 2000-2005 Agilent Technologies</p> <p>Center Freq: 5.3100000 GHz Start Freq: 5.2875000 GHz Stop Freq: 5.3325000 GHz CF Step: 4.5000000 MHz (Auto/Man) Freq Offset: 0.0000000 Hz Signal Track: On/Off</p>



Mode 4: IEEE 802.11n 40MHz Link Mode	
5510	<p>Agilent T Freq/Channel</p> <p>Ref 20 dBm Atten 20 dB <math>\Delta</math> Mkr1 0 Hz -8.089 dB</p> <p>#Avg Log 10 dB/Offst 11.8 dB</p> <p>PAvg 100 M1 W2 S3 FS AL <math>\mathcal{E}(f)</math>: FTun Swp</p> <p>Center 5.510 00 GHz Span 45 MHz #Res BW 1 MHz *VBW 3 MHz Sweep 1 ms (601 pts)</p> <p>Copyright 2000-2005 Agilent Technologies</p> <p>Center Freq 5.5100000 GHz</p> <p>Start Freq 5.4875000 GHz</p> <p>Stop Freq 5.5325000 GHz</p> <p>CF Step 4.5000000 MHz Auto Man</p> <p>Freq Offset 0.0000000 Hz</p> <p>Signal Track On Off</p>
5590	<p>Agilent T Freq/Channel</p> <p>Ref 20 dBm Atten 20 dB <math>\Delta</math> Mkr1 0 Hz -7.920 dB</p> <p>#Avg Log 10 dB/Offst 11.8 dB</p> <p>PAvg 100 M1 W2 S3 FS AL <math>\mathcal{E}(f)</math>: FTun Swp</p> <p>Center 5.590 00 GHz Span 45 MHz #Res BW 1 MHz *VBW 3 MHz Sweep 1 ms (601 pts)</p> <p>Copyright 2000-2005 Agilent Technologies</p> <p>Center Freq 5.5900000 GHz</p> <p>Start Freq 5.5675000 GHz</p> <p>Stop Freq 5.6125000 GHz</p> <p>CF Step 4.5000000 MHz Auto Man</p> <p>Freq Offset 0.0000000 Hz</p> <p>Signal Track On Off</p>
5670	<p>Agilent T Freq/Channel</p> <p>Ref 20 dBm Atten 20 dB <math>\Delta</math> Mkr1 0 Hz -8.113 dB</p> <p>#Avg Log 10 dB/Offst 11.8 dB</p> <p>PAvg 100 M1 W2 S3 FS AL <math>\mathcal{E}(f)</math>: FTun Swp</p> <p>Center 5.670 00 GHz Span 45 MHz #Res BW 1 MHz *VBW 3 MHz Sweep 1 ms (601 pts)</p> <p>Copyright 2000-2005 Agilent Technologies</p> <p>Center Freq 5.6700000 GHz</p> <p>Start Freq 5.6475000 GHz</p> <p>Stop Freq 5.6925000 GHz</p> <p>CF Step 4.5000000 MHz Auto Man</p> <p>Freq Offset 0.0000000 Hz</p> <p>Signal Track On Off</p>

## 9 Peak Power Spectral Density Measurement

### 9.1. Limit

Frequency Range (MHz)	FCC Limit	CANADA EIRP Limit
5.150 ~ 5.250 GHz	4 dBm	10 dBm
5.250 ~ 5.350 GHz	11 dBm	11 dBm
5.470 ~ 5.725 GHz	11 dBm	11 dBm

### 9.2. Test Setup

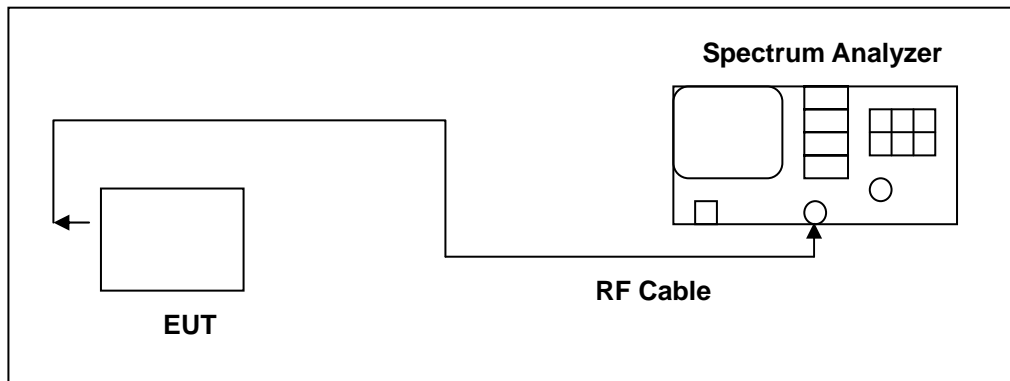

### 9.3. Test Instruments

Equipment	Manufacturer	Model Number	Serial Number	Cal. Date	Remark
Spectrum Analyzer	Agilent	E4445A	MY45300744	12/19/2012	(1)
Test Site	ATL	TE02	TE02	N.C.R.	-----

Remark: (1) Calibration period 1 year. (2) Calibration period 2 years.

NOTE: N.C.R. = No Calibration Request.

### 9.4. Test Procedure

The test is performed in accordance with KDB789033: D01 General UNII Test Procedures v01r03, Guidelines for Compliance Testing of Unlicensed National Information Infrastructure (U-NII) Devices - Part 15, Subpart E.

**9.5. Test Result**

Model Number	PS2 Speaker				
Test Item	Peak Power Spectral Density				
Test Mode	Mode 2: IEEE 802.11a Link Mode				
Date of Test	04/29/2013			Test Site	TE02
Frequency (MHz)	FCC		CANADA		
	Measurement (dBm)	Limit (dBm)	EIRP (dBm)	Limit (dBm)	
5180	2.288	< 4	7.668	< 10	
5220	2.879	< 4	8.259	< 10	
5240	2.766	< 4	8.146	< 10	
5260	2.672	< 11	8.052	< 11	
5280	2.495	< 11	7.875	< 11	
5320	1.372	< 11	6.752	< 11	
5500	1.077	< 11	6.457	< 11	
5580	1.395	< 11	6.775	< 11	
5700	2.243	< 11	7.623	< 11	

Model Number	PS2 Speaker				
Test Item	Peak Power Spectral Density				
Test Mode	Mode 3: IEEE 802.11n 20MHz Link Mode				
Date of Test	04/29/2013			Test Site	TE02
Frequency (MHz)	FCC		CANADA		
	Measurement (dBm)	Limit (dBm)	EIRP (dBm)	Limit (dBm)	
5180	0.026	< 4	5.406	< 10	
5220	0.747	< 4	6.127	< 10	
5240	0.390	< 4	5.770	< 10	
5260	0.264	< 11	5.644	< 11	
5280	0.043	< 11	5.423	< 11	
5320	-1.181	< 11	4.199	< 11	
5500	-1.476	< 11	3.904	< 11	
5580	-1.129	< 11	4.251	< 11	
5700	-1.952	< 11	3.428	< 11	

EIRP = Peak Power Spectral Density + Antenna Gain

Model Number	PS2 Speaker				
Test Item	Peak Power Spectral Density				
Test Mode	Mode 4: IEEE 802.11n 40MHz Link Mode				
Date of Test	04/29/2013			Test Site	TE02
Frequency (MHz)	FCC		CANADA		
	Measurement (dBm)	Limit (dBm)	EIRP (dBm)	Limit (dBm)	
5190	-2.190	< 4	3.190	< 10	
5230	-2.265	< 4	3.115	< 10	
5270	-2.582	< 11	2.798	< 11	
5310	-3.901	< 11	1.479	< 11	
5510	-2.684	< 11	2.696	< 11	
5590	-2.813	< 11	2.567	< 11	
5670	-3.203	< 11	2.177	< 11	

EIRP = Peak Power Spectral Density + Antenna Gain

**9.6. Test Graphs**

Mode 2: IEEE 802.11a Link Mode	
5180	
5220	
5240	

Mode 2: IEEE 802.11a Link Mode	
5260	
5280	
5320	

Mode 2: IEEE 802.11a Link Mode	
5500	<p>Agilent T</p> <p>Ref 20 dBm Atten 20 dB Mkr1 5.50247 GHz #Avg 1.077 dBm</p> <p>Log 10 dB/Offst 11.8 dB</p> <p>PAvg 100 W1 S2 S3 FS AL</p> <p>Ⓔ(f): FTun Swp</p> <p>Center 5.500 00 GHz Span 28 MHz #Res BW 1 MHz *VBW 3 MHz Sweep 1 ms (601 pts)</p> <p>Copyright 2000-2005 Agilent Technologies</p> <p><b>Freq/Channel</b></p> <p>Center Freq 5,50000000 GHz</p> <p>Start Freq 5,48600000 GHz</p> <p>Stop Freq 5,51400000 GHz</p> <p>CF Step 2,80000000 MHz Auto Man</p> <p>Freq Offset 0,00000000 Hz</p> <p>Signal Track On Off</p>
5580	<p>Agilent R T</p> <p>Ref 20 dBm Atten 20 dB Mkr1 5.58126 GHz #Avg 1.395 dBm</p> <p>Log 10 dB/Offst 11.8 dB</p> <p>PAvg 100 W1 S2 S3 FS AL</p> <p>Ⓔ(f): FTun Swp</p> <p>Start 5,566 00 GHz Stop 5,594 00 GHz #Res BW 1 MHz *VBW 3 MHz Sweep 1 ms (601 pts)</p> <p>Copyright 2000-2005 Agilent Technologies</p> <p><b>Freq/Channel</b></p> <p>Center Freq 5,58000000 GHz</p> <p>Start Freq 5,56600000 GHz</p> <p>Stop Freq 5,59400000 GHz</p> <p>CF Step 2,80000000 MHz Auto Man</p> <p>Freq Offset 0,00000000 Hz</p> <p>Signal Track On Off</p>
5700	<p>Agilent T</p> <p>Ref 20 dBm Atten 20 dB Mkr1 5.69543 GHz #Avg 2.243 dBm</p> <p>Log 10 dB/Offst 11.8 dB</p> <p>PAvg 100 W1 S2 S3 FS AL</p> <p>Ⓔ(f): FTun Swp</p> <p>Center 5,700 00 GHz Span 28 MHz #Res BW 1 MHz *VBW 3 MHz Sweep 1 ms (601 pts)</p> <p>Copyright 2000-2005 Agilent Technologies</p> <p><b>Freq/Channel</b></p> <p>Center Freq 5,70000000 GHz</p> <p>Start Freq 5,68600000 GHz</p> <p>Stop Freq 5,71400000 GHz</p> <p>CF Step 2,80000000 MHz Auto Man</p> <p>Freq Offset 0,00000000 Hz</p> <p>Signal Track On Off</p>

Mode 3: IEEE 802.11n 20MHz Link Mode	
5180	<p>Agilent T Freq/Channel</p> <p>Ref 20 dBm Atten 20 dB Mkr1 5.178 92 GHz 0.026 dBm</p> <p>#Avg Log 10 dB/ Offst 11.8 dB</p> <p>PAvg 100 W1 S2 S3 FS AL</p> <p>£(f): FTun Swp</p> <p>Center 5.180 00 GHz Span 31 MHz #Res BW 1 MHz *VBW 3 MHz Sweep 1 ms (601 pts)</p> <p>Copyright 2000-2005 Agilent Technologies</p> <p>Center Freq 5.18000000 GHz</p> <p>Start Freq 5.16450000 GHz</p> <p>Stop Freq 5.19550000 GHz</p> <p>CF Step 3.10000000 MHz Auto Man</p> <p>Freq Offset 0.00000000 Hz</p> <p>Signal Track On Off</p>
5220	<p>Agilent T Freq/Channel</p> <p>Ref 20 dBm Atten 20 dB Mkr1 5.227 08 GHz 0.747 dBm</p> <p>#Avg Log 10 dB/ Offst 11.8 dB</p> <p>PAvg 100 W1 S2 S3 FS AL</p> <p>£(f): FTun Swp</p> <p>Center 5.220 00 GHz Span 31 MHz #Res BW 1 MHz *VBW 3 MHz Sweep 1 ms (601 pts)</p> <p>Copyright 2000-2005 Agilent Technologies</p> <p>Center Freq 5.22000000 GHz</p> <p>Start Freq 5.20450000 GHz</p> <p>Stop Freq 5.23550000 GHz</p> <p>CF Step 3.10000000 MHz Auto Man</p> <p>Freq Offset 0.00000000 Hz</p> <p>Signal Track On Off</p>
5240	<p>Agilent T Freq/Channel</p> <p>Ref 20 dBm Atten 20 dB Mkr1 5.241 14 GHz 0.390 dBm</p> <p>#Avg Log 10 dB/ Offst 11.8 dB</p> <p>PAvg 100 W1 S2 S3 FS AL</p> <p>£(f): FTun Swp</p> <p>Center 5.240 00 GHz Span 31 MHz #Res BW 1 MHz *VBW 3 MHz Sweep 1 ms (601 pts)</p> <p>Copyright 2000-2005 Agilent Technologies</p> <p>Center Freq 5.24000000 GHz</p> <p>Start Freq 5.22450000 GHz</p> <p>Stop Freq 5.25550000 GHz</p> <p>CF Step 3.10000000 MHz Auto Man</p> <p>Freq Offset 0.00000000 Hz</p> <p>Signal Track On Off</p>



Mode 3: IEEE 802.11n 20MHz Link Mode	
5260	<p>Agilent T Freq/Channel</p> <p>Ref 20 dBm Atten 20 dB Mkr1 5.261 81 GHz #Avg 0.264 dBm</p> <p>Log 10 dB/Offst 11.8 dB</p> <p>PAvg 100 W1 S2 S3 FS AL</p> <p>£(f): FTun Swp</p> <p>Center 5.260 00 GHz Span 31 MHz #Res BW 1 MHz *VBW 3 MHz Sweep 1 ms (601 pts)</p> <p>Copyright 2000-2005 Agilent Technologies</p> <p>Center Freq 5.26000000 GHz Start Freq 5.24450000 GHz Stop Freq 5.27550000 GHz CF Step 3.10000000 MHz Auto Man Freq Offset 0.00000000 Hz Signal Track On Off</p>
5280	<p>Agilent T Freq/Channel</p> <p>Ref 20 dBm Atten 20 dB Mkr1 5.272 35 GHz #Avg 0.043 dBm</p> <p>Log 10 dB/Offst 11.8 dB</p> <p>PAvg 100 W1 S2 S3 FS AL</p> <p>£(f): FTun Swp</p> <p>Center 5.280 00 GHz Span 31 MHz #Res BW 1 MHz *VBW 3 MHz Sweep 1 ms (601 pts)</p> <p>Copyright 2000-2005 Agilent Technologies</p> <p>Center Freq 5.28000000 GHz Start Freq 5.26450000 GHz Stop Freq 5.29550000 GHz CF Step 3.10000000 MHz Auto Man Freq Offset 0.00000000 Hz Signal Track On Off</p>
5320	<p>Agilent T Freq/Channel</p> <p>Ref 20 dBm Atten 20 dB Mkr1 5.314 63 GHz #Avg -1.181 dBm</p> <p>Log 10 dB/Offst 11.8 dB</p> <p>PAvg 100 W1 S2 S3 FS AL</p> <p>£(f): FTun Swp</p> <p>Center 5.320 00 GHz Span 31 MHz #Res BW 1 MHz *VBW 3 MHz Sweep 1 ms (601 pts)</p> <p>Copyright 2000-2005 Agilent Technologies</p> <p>Center Freq 5.32000000 GHz Start Freq 5.30450000 GHz Stop Freq 5.33550000 GHz CF Step 3.10000000 MHz Auto Man Freq Offset 0.00000000 Hz Signal Track On Off</p>

Mode 3: IEEE 802.11n 20MHz Link Mode															
5500	<p>Agilent T</p> <p>Ref 20 dBm Atten 20 dB Mkr1 5.502 92 GHz -1.476 dBm</p> <p>#Avg Log 10 dB/ Offst 11.8 dB</p> <p>PAvg 100 W1 S2 S3 FS AL</p> <p>£(f): FTun Swp</p> <p>Center 5.500 00 GHz Span 24 MHz #Res BN 1 MHz *VBW 3 MHz Sweep 1 ms (601 pts)</p> <p>Copyright 2000-2005 Agilent Technologies</p> <table border="1"> <tr><th colspan="2">Freq/Channel</th></tr> <tr><td>Center Freq</td><td>5,50000000 GHz</td></tr> <tr><td>Start Freq</td><td>5,48800000 GHz</td></tr> <tr><td>Stop Freq</td><td>5,51200000 GHz</td></tr> <tr><td>CF Step</td><td>2,40000000 MHz Auto Man</td></tr> <tr><td>Freq Offset</td><td>0,00000000 Hz</td></tr> <tr><td>Signal Track</td><td>On Off</td></tr> </table>	Freq/Channel		Center Freq	5,50000000 GHz	Start Freq	5,48800000 GHz	Stop Freq	5,51200000 GHz	CF Step	2,40000000 MHz Auto Man	Freq Offset	0,00000000 Hz	Signal Track	On Off
Freq/Channel															
Center Freq	5,50000000 GHz														
Start Freq	5,48800000 GHz														
Stop Freq	5,51200000 GHz														
CF Step	2,40000000 MHz Auto Man														
Freq Offset	0,00000000 Hz														
Signal Track	On Off														
5580	<p>Agilent R T</p> <p>Ref 20 dBm Atten 20 dB Mkr1 5.583 40 GHz -1.129 dBm</p> <p>#Avg Log 10 dB/ Offst 11.8 dB</p> <p>PAvg 100 W1 S2 S3 FS AL</p> <p>£(f): FTun Swp</p> <p>Center 5.580 00 GHz Span 24 MHz #Res BN 1 MHz *VBW 3 MHz Sweep 1 ms (601 pts)</p> <p>Copyright 2000-2005 Agilent Technologies</p> <table border="1"> <tr><th colspan="2">Freq/Channel</th></tr> <tr><td>Center Freq</td><td>5,58000000 GHz</td></tr> <tr><td>Start Freq</td><td>5,56800000 GHz</td></tr> <tr><td>Stop Freq</td><td>5,59200000 GHz</td></tr> <tr><td>CF Step</td><td>2,40000000 MHz Auto Man</td></tr> <tr><td>Freq Offset</td><td>0,00000000 Hz</td></tr> <tr><td>Signal Track</td><td>On Off</td></tr> </table>	Freq/Channel		Center Freq	5,58000000 GHz	Start Freq	5,56800000 GHz	Stop Freq	5,59200000 GHz	CF Step	2,40000000 MHz Auto Man	Freq Offset	0,00000000 Hz	Signal Track	On Off
Freq/Channel															
Center Freq	5,58000000 GHz														
Start Freq	5,56800000 GHz														
Stop Freq	5,59200000 GHz														
CF Step	2,40000000 MHz Auto Man														
Freq Offset	0,00000000 Hz														
Signal Track	On Off														
5700	<p>Agilent T</p> <p>Ref 20 dBm Atten 20 dB Mkr1 5.696 76 GHz -1.952 dBm</p> <p>#Avg Log 10 dB/ Offst 11.8 dB</p> <p>PAvg 100 W1 S2 S3 FS AL</p> <p>£(f): FTun Swp</p> <p>Center 5.700 00 GHz Span 24 MHz #Res BN 1 MHz *VBW 3 MHz Sweep 1 ms (601 pts)</p> <p>Copyright 2000-2005 Agilent Technologies</p> <table border="1"> <tr><th colspan="2">Freq/Channel</th></tr> <tr><td>Center Freq</td><td>5,70000000 GHz</td></tr> <tr><td>Start Freq</td><td>5,68800000 GHz</td></tr> <tr><td>Stop Freq</td><td>5,71200000 GHz</td></tr> <tr><td>CF Step</td><td>2,40000000 MHz Auto Man</td></tr> <tr><td>Freq Offset</td><td>0,00000000 Hz</td></tr> <tr><td>Signal Track</td><td>On Off</td></tr> </table>	Freq/Channel		Center Freq	5,70000000 GHz	Start Freq	5,68800000 GHz	Stop Freq	5,71200000 GHz	CF Step	2,40000000 MHz Auto Man	Freq Offset	0,00000000 Hz	Signal Track	On Off
Freq/Channel															
Center Freq	5,70000000 GHz														
Start Freq	5,68800000 GHz														
Stop Freq	5,71200000 GHz														
CF Step	2,40000000 MHz Auto Man														
Freq Offset	0,00000000 Hz														
Signal Track	On Off														

Mode 4: IEEE 802.11n 40MHz Link Mode

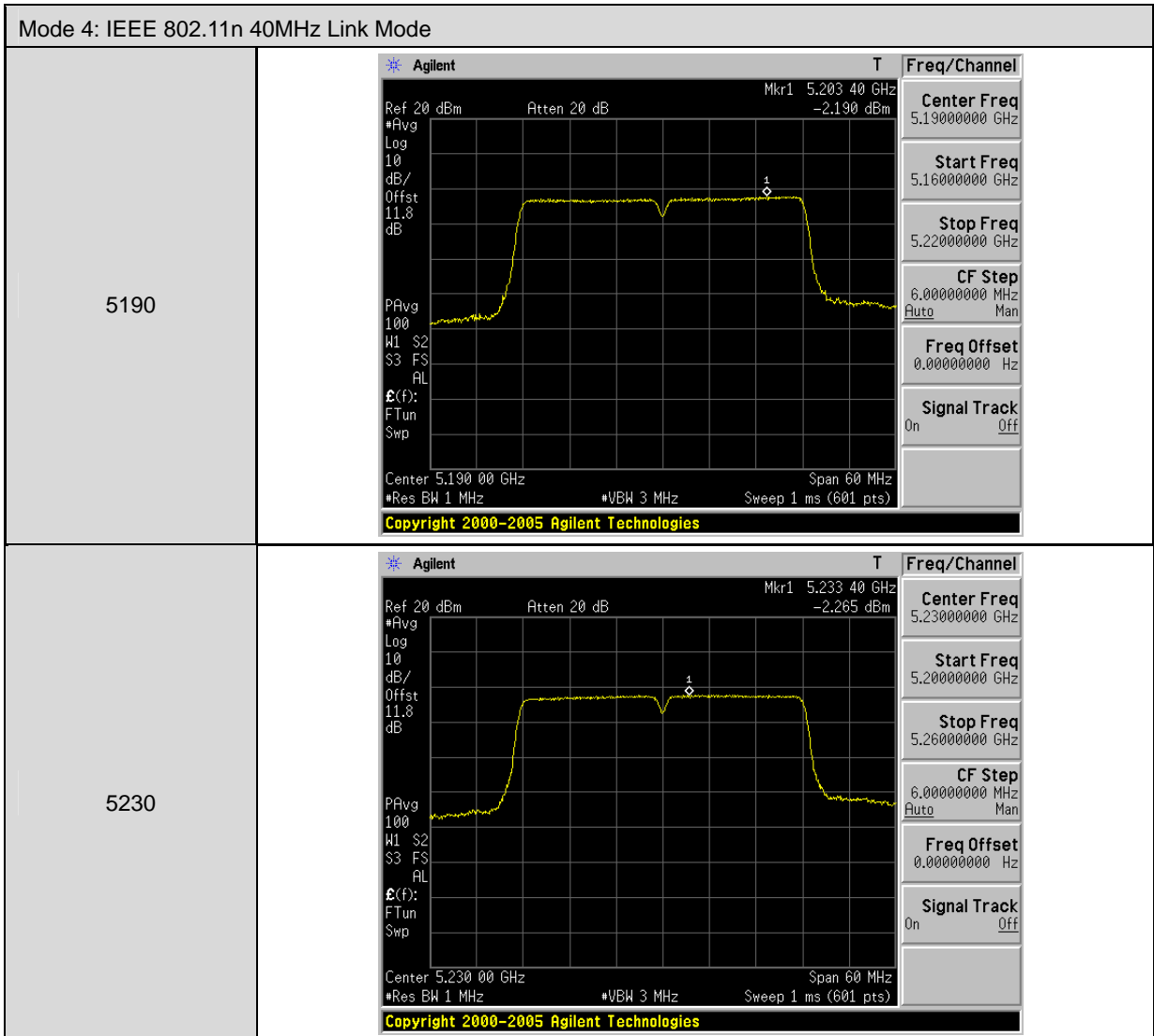

Mode 4: IEEE 802.11n 40MHz Link Mode

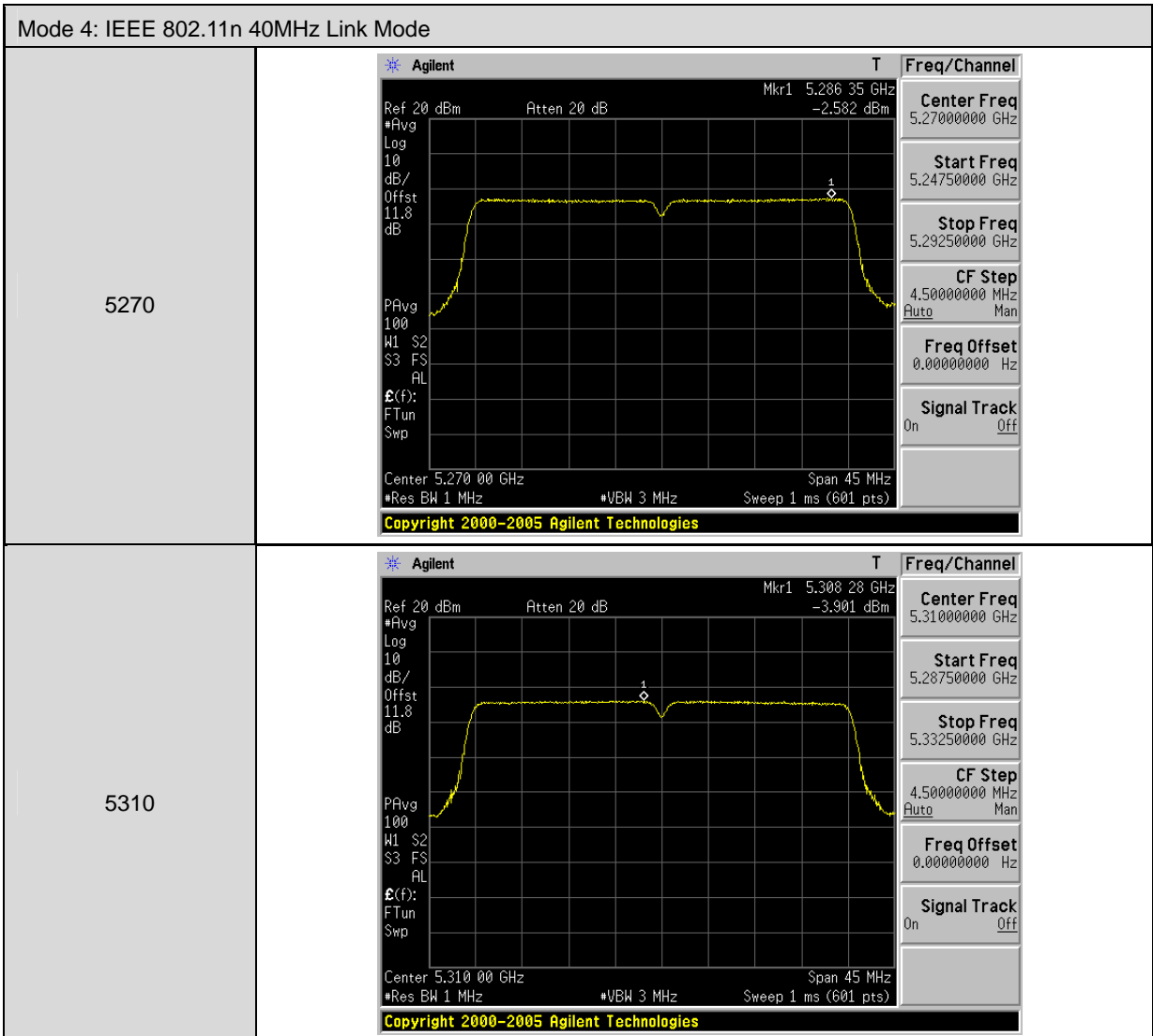

Mode 4: IEEE 802.11n 40MHz Link Mode	
5510	<p>Agilent T Freq/Channel</p> <p>Ref 20 dBm Atten 20 dB Mkr1 5.526 95 GHz -2.684 dBm</p> <p>#Avg Log 10 dB/ Offst 11.8 dB</p> <p>PAvg 100 W1 S2 S3 FS AL</p> <p>£(f): FTun Swp</p> <p>Center 5.510 00 GHz Span 45 MHz #Res BW 1 MHz *VBW 3 MHz Sweep 1 ms (601 pts)</p> <p>Copyright 2000-2005 Agilent Technologies</p> <p>Center Freq 5.5100000 GHz Start Freq 5.48750000 GHz Stop Freq 5.53250000 GHz CF Step 4.50000000 MHz Auto Man Freq Offset 0.00000000 Hz Signal Track On Off</p>
5590	<p>Agilent T Freq/Channel</p> <p>Ref 20 dBm Atten 20 dB Mkr1 5.588 50 GHz -2.813 dBm</p> <p>#Avg Log 10 dB/ Offst 11.8 dB</p> <p>PAvg 100 W1 S2 S3 FS AL</p> <p>£(f): FTun Swp</p> <p>Center 5.590 00 GHz Span 45 MHz #Res BW 1 MHz *VBW 3 MHz Sweep 1 ms (601 pts)</p> <p>Copyright 2000-2005 Agilent Technologies</p> <p>Center Freq 5.5900000 GHz Start Freq 5.56750000 GHz Stop Freq 5.61250000 GHz CF Step 4.50000000 MHz Auto Man Freq Offset 0.00000000 Hz Signal Track On Off</p>
5670	<p>Agilent T Freq/Channel</p> <p>Ref 20 dBm Atten 20 dB Mkr1 5.672 78 GHz -3.203 dBm</p> <p>#Avg Log 10 dB/ Offst 11.8 dB</p> <p>PAvg 100 W1 S2 S3 FS AL</p> <p>£(f): FTun Swp</p> <p>Center 5.670 00 GHz Span 45 MHz #Res BW 1 MHz *VBW 3 MHz Sweep 1 ms (601 pts)</p> <p>Copyright 2000-2005 Agilent Technologies</p> <p>Center Freq 5.6700000 GHz Start Freq 5.64750000 GHz Stop Freq 5.69250000 GHz CF Step 4.50000000 MHz Auto Man Freq Offset 0.00000000 Hz Signal Track On Off</p>

## 10 Frequency Stability Measurement

### 10.1. Limit

The frequency tolerance of the carrier signal shall be maintained within the band of operation frequency over a temperature variation of  $-30$  degrees to  $50$  degrees C at normal supply voltage, and for a variation in the primary supply voltage from 85% to 115% of the rated supply voltage at a temperature of  $20$  degrees C.

### 10.2. Test Setup

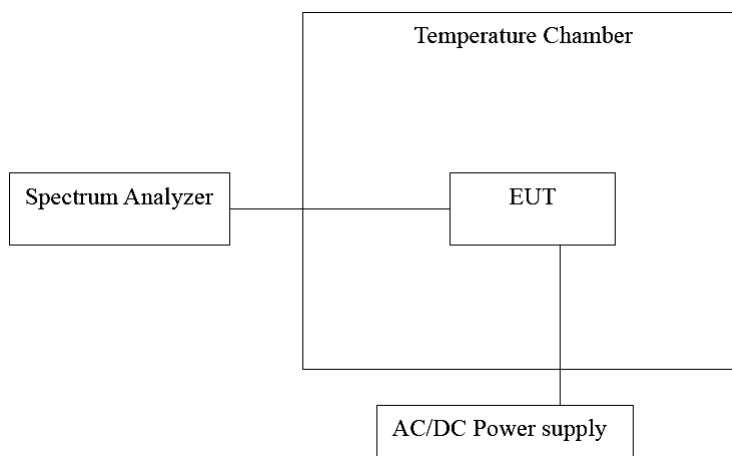

### 10.3. Test Instruments

Equipment	Manufacturer	Model Number	Serial Number	Cal. Date	Remark
Spectrum Analyzer	Agilent	E4408B	MY45107753	07/09/2012	(1)
Temperature & Humidity Chamber	TAICHY	MHU-225LA	980729	08/07/2012	(1)
Test Site	ATL	TE02	TE02	N.C.R.	-----

Remark: <sup>(1)</sup> Calibration period 1 year. <sup>(2)</sup> Calibration period 2 years.

NOTE: N.C.R. = No Calibration Request.

### 10.4. Test Procedure

1. The EUT was placed inside the environmental test chamber and powered by nominal DC voltage.
2. Turn the EUT on and couple its output to a spectrum analyzer.
3. Turn the EUT off and set the chamber to the highest temperature specified.
4. Allow sufficient time (approximately 30 min) for the temperature of the chamber to stabilize.
5. Repeat step 2 and 3 with the temperature chamber set to the lowest temperature.
6. The test chamber was allowed to stabilize at +20 degree C for a minimum of 30 minutes. The supply voltage was then adjusted on the EUT from 85% to 115% and the frequency record.

### 10.5. Test Result

#### Temperature Variations

Model Number	PS2 Speaker				
Mode	Mode 2				
Frequency	5220 MHz				
Date of Test	04/29/2013			Test Site	TE02
Temp. (°C)	Voltage (Vac)	Measured Frequency (MHz)	Delta Frequency (Hz)	Tolerance (ppm)	Result (Pass/Fail)
-30	120	5219.9583	-41700	7.989	Pass
-20		5219.9697	-30300	5.805	Pass
-10		5220.0096	9600	-1.839	Pass
0		5219.9632	-36800	7.050	Pass
10		5220.0394	39400	-7.548	Pass
20		5219.9909	-9100	1.743	Pass
30		5219.9744	-25600	4.904	Pass
40		5219.9762	-23800	4.559	Pass
50		5220.0048	4800	-0.920	Pass

Model Number	PS2 Speaker				
Mode	Mode 2				
Frequency	5280 MHz				
Date of Test	04/29/2013			Test Site	TE02
Temp. (°C)	Voltage (Vac)	Measured Frequency (MHz)	Delta Frequency (Hz)	Tolerance (ppm)	Result (Pass/Fail)
-30	120	5280.0212	21200	-4.015	Pass
-20		5279.9554	-44600	8.447	Pass
-10		5279.9576	-42400	8.030	Pass
0		5280.0245	24500	-4.640	Pass
10		5279.9627	-37300	7.064	Pass
20		5280.0086	8600	-1.629	Pass
30		5279.9551	-44900	8.504	Pass
40		5279.9766	-23400	4.432	Pass
50		5280.0238	23800	-4.508	Pass

Model Number	PS2 Speaker				
Mode	Mode 2				
Frequency	5580 MHz				
Date of Test	04/29/2013			Test Site	TE02
Temp. (°C)	Voltage (Vac)	Measured Frequency (MHz)	Delta Frequency (Hz)	Tolerance (ppm)	Result (Pass/Fail)
-30	120	5579.9538	-46200	8.280	Pass
-20		5579.9932	-6800	1.219	Pass
-10		5580.0288	28800	-5.161	Pass
0		5580.0371	37100	-6.649	Pass
10		5580.0064	6400	-1.147	Pass
20		5580.0119	11900	-2.133	Pass
30		5580.0399	39900	-7.151	Pass
40		5579.9959	-4100	0.735	Pass
50		5579.9813	-18700	3.351	Pass



Model Number	PS2 Speaker				
Mode	Mode 3				
Frequency	5220 MHz				
Date of Test	04/29/2013			Test Site	TE02
Temp. (°C)	Voltage (Vac)	Measured Frequency (MHz)	Delta Frequency (Hz)	Tolerance (ppm)	Result (Pass/Fail)
-30	120	5220.0115	11500	-2.203	Pass
-20		5220.0015	1500	-0.287	Pass
-10		5219.9597	-40300	7.720	Pass
0		5220.0481	48100	-9.215	Pass
10		5219.9698	-30200	5.785	Pass
20		5220.0398	39800	-7.625	Pass
30		5219.9835	-16500	3.161	Pass
40		5220.0017	1700	-0.326	Pass
50		5219.9872	-12800	2.452	Pass

Model Number	PS2 Speaker				
Mode	Mode 3				
Frequency	5280 MHz				
Date of Test	04/29/2013			Test Site	TE02
Temp. (°C)	Voltage (Vac)	Measured Frequency (MHz)	Delta Frequency (Hz)	Tolerance (ppm)	Result (Pass/Fail)
-30	120	5279.9884	-11600	2.197	Pass
-20		5280.0259	25900	-4.905	Pass
-10		5279.9577	-42300	8.011	Pass
0		5280.0015	1500	-0.284	Pass
10		5279.9672	-32800	6.212	Pass
20		5279.9504	-49600	9.394	Pass
30		5280.0237	23700	-4.489	Pass
40		5279.9597	-40300	7.633	Pass
50		5280.0096	9600	-1.818	Pass

Model Number	PS2 Speaker				
Mode	Mode 3				
Frequency	5580 MHz				
Date of Test	04/29/2013			Test Site	TE02
Temp. (°C)	Voltage (Vac)	Measured Frequency (MHz)	Delta Frequency (Hz)	Tolerance (ppm)	Result (Pass/Fail)
-30	120	5579.9859	-14100	2.527	Pass
-20		5580.0287	28700	-5.143	Pass
-10		5579.9806	-19400	3.477	Pass
0		5580.0363	36300	-6.505	Pass
10		5580.0179	17900	-3.208	Pass
20		5580.0262	26200	-4.695	Pass
30		5579.9797	-20300	3.638	Pass
40		5580.0068	6800	-1.219	Pass
50		5579.9661	-33900	6.075	Pass

Model Number	PS2 Speaker				
Mode	Mode 4				
Frequency	5190 MHz				
Date of Test	04/29/2013			Test Site	TE02
Temp. (°C)	Voltage (Vac)	Measured Frequency (MHz)	Delta Frequency (Hz)	Tolerance (ppm)	Result (Pass/Fail)
-30	120	5190.0498	49800	-9.595	Pass
-20		5190.0228	22800	-4.393	Pass
-10		5189.9504	-49600	9.557	Pass
0		5189.9580	-42000	8.092	Pass
10		5190.0174	17400	-3.353	Pass
20		5189.9830	-17000	3.276	Pass
30		5189.9657	-34300	6.609	Pass
40		5190.0079	7900	-1.522	Pass
50		5190.0091	9100	-1.753	Pass

Model Number	PS2 Speaker				
Mode	Mode 4				
Frequency	5270 MHz				
Date of Test	04/29/2013			Test Site	TE02
Temp. (°C)	Voltage (Vac)	Measured Frequency (MHz)	Delta Frequency (Hz)	Tolerance (ppm)	Result (Pass/Fail)
-30	120	5270.0495	49500	-9.393	Pass
-20		5270.0173	17300	-3.283	Pass
-10		5269.9857	-14300	2.713	Pass
0		5269.9541	-45900	8.710	Pass
10		5270.0130	13000	-2.467	Pass
20		5269.9502	-49800	9.450	Pass
30		5269.9994	-600	0.114	Pass
40		5269.9934	-6600	1.252	Pass
50		5269.9664	-33600	6.376	Pass

Model Number	PS2 Speaker				
Mode	Mode 4				
Frequency	5590 MHz				
Date of Test	04/29/2013			Test Site	TE02
Temp. (°C)	Voltage (Vac)	Measured Frequency (MHz)	Delta Frequency (Hz)	Tolerance (ppm)	Result (Pass/Fail)
-30	120	5589.9739	-26100	4.669	Pass
-20		5590.0040	4000	-0.716	Pass
-10		5590.0342	34200	-6.118	Pass
0		5590.0094	9400	-1.682	Pass
10		5589.9544	-45600	8.157	Pass
20		5590.0191	19100	-3.417	Pass
30		5589.9884	-11600	2.075	Pass
40		5590.0055	5500	-0.984	Pass
50		5590.0259	25900	-4.633	Pass

**Voltage Variations**

Model Number	PS2 Speaker				
Mode	Mode 2				
Frequency	5220 MHz				
Date of Test	04/29/2013			Test Site	TE02
Temp. (°C)	Voltage (Vac)	Measured Frequency (MHz)	Delta Frequency (Hz)	Tolerance (ppm)	Result (Pass/Fail)
20	138.00	5220.0364	36400	-6.973	Pass
	120.00	5220.0239	23900	-4.579	Pass
	102.00	5220.0039	3900	-0.747	Pass

Model Number	PS2 Speaker				
Mode	Mode 2				
Frequency	5280 MHz				
Date of Test	04/29/2013			Test Site	TE02
Temp. (°C)	Voltage (Vac)	Measured Frequency (MHz)	Delta Frequency (Hz)	Tolerance (ppm)	Result (Pass/Fail)
20	138.00	5279.9892	-10800	2.045	Pass
	120.00	5279.9893	-10700	2.027	Pass
	102.00	5279.9837	-16300	3.087	Pass

Model Number	PS2 Speaker				
Mode	Mode 2				
Frequency	5580 MHz				
Date of Test	04/29/2013			Test Site	TE02
Temp. (°C)	Voltage (Vac)	Measured Frequency (MHz)	Delta Frequency (Hz)	Tolerance (ppm)	Result (Pass/Fail)
20	138.00	5579.9782	-21800	3.907	Pass
	120.00	5579.9863	-13700	2.455	Pass
	102.00	5579.9546	-45400	8.136	Pass

Model Number	PS2 Speaker				
Mode	Mode 3				
Frequency	5220 MHz				
Date of Test	04/29/2013			Test Site	TE02
Temp. (°C)	Voltage (Vac)	Measured Frequency (MHz)	Delta Frequency (Hz)	Tolerance (ppm)	Result (Pass/Fail)
20	138.00	5219.9943	-5700	1.092	Pass
	120.00	5219.9558	-44200	8.467	Pass
	102.00	5220.0267	26700	-5.115	Pass

Model Number	PS2 Speaker				
Mode	Mode 3				
Frequency	5280 MHz				
Date of Test	04/29/2013			Test Site	TE02
Temp. (°C)	Voltage (Vac)	Measured Frequency (MHz)	Delta Frequency (Hz)	Tolerance (ppm)	Result (Pass/Fail)
20	138.00	5279.9576	-42400	8.030	Pass
	120.00	5280.0291	29100	-5.511	Pass
	102.00	5279.9759	-24100	4.564	Pass

Model Number	PS2 Speaker				
Mode	Mode 3				
Frequency	5580 MHz				
Date of Test	04/29/2013			Test Site	TE02
Temp. (°C)	Voltage (Vac)	Measured Frequency (MHz)	Delta Frequency (Hz)	Tolerance (ppm)	Result (Pass/Fail)
20	138.00	5579.9562	-43800	7.849	Pass
	120.00	5580.0209	20900	-3.746	Pass
	102.00	5579.9633	-36700	6.577	Pass

Model Number	PS2 Speaker				
Mode	Mode 4				
Frequency	5190 MHz				
Date of Test	04/29/2013			Test Site	TE02
Temp. (°C)	Voltage (Vac)	Measured Frequency (MHz)	Delta Frequency (Hz)	Tolerance (ppm)	Result (Pass/Fail)
20	138.00	5190.0472	47200	-9.094	Pass
	120.00	5189.9811	-18900	3.642	Pass
	102.00	5189.9698	-30200	5.819	Pass

Model Number	PS2 Speaker				
Mode	Mode 4				
Frequency	5270 MHz				
Date of Test	04/29/2013			Test Site	TE02
Temp. (°C)	Voltage (Vac)	Measured Frequency (MHz)	Delta Frequency (Hz)	Tolerance (ppm)	Result (Pass/Fail)
20	138.00	5270.0135	13500	-2.562	Pass
	120.00	5270.0018	1800	-0.342	Pass
	102.00	5270.0275	27500	-5.218	Pass

Model Number	PS2 Speaker				
Mode	Mode 4				
Frequency	5590 MHz				
Date of Test	04/29/2013			Test Site	TE02
Temp. (°C)	Voltage (Vac)	Measured Frequency (MHz)	Delta Frequency (Hz)	Tolerance (ppm)	Result (Pass/Fail)
20	138.00	5589.9917	-8300	1.485	Pass
	120.00	5590.0158	15800	-2.826	Pass
	102.00	5589.9855	-14500	2.594	Pass

## 11 Antenna Measurement

### 11.1.Limit

For intentional device, according to 15.203, an intentional radiator shall be designed to ensure that no antenna other than that furnished by the responsible party shall be used with the device.

And According to 15.407 (a), if transmitting antennas of directional gain greater than 6 dBi are used, the power shall be reduced by the amount in dB that the directional gain of the antenna exceeds 6dBi.

### 11.2.Antenna Connector Construction

The antenna used in this product is PIFA antenna. And the maximum gain of the antenna is listed below.

Frequency Band	ANTL	ANTR
IEEE 802.11a / IEEE 802.11n (5GHz) 20MHz / 40MHz	4.07 dBi	5.38 dBi