

FCC 47 CFR PART 15 SUBPART C

Product Type : Play-Fi Player
Applicant : Phorus, Inc.
Address : 16255 Ventura Boulevard, Suite 310, Encino, United States, 91436
Trade Name : Phorus
Model Number : PS2 Speaker
Test Specification : FCC 47 CFR PART 15 SUBPART C: Oct., 2012
Canada RSS-210 ISSUE 8: Dec., 2010
Canada RSS-Gen ISSUE 3: Dec., 2010
ANSI C63.4-2009
Receive Date : Apr. 18, 2013
Test Period : Apr. 30~May 16, 2013
Issue Date : Sep. 04, 2013

Issue by

A Test Lab Techno Corp.
No. 140-1, Changan Street, Bade City,
Taoyuan County 334, Taiwan R.O.C.
Tel : +886-3-2710188 / Fax : +886-3-2710190



Taiwan Accreditation Foundation accreditation number: 1330

Note: This report shall not be reproduced except in full, without the written approval of A Test Lab Techno Corp. This document may be altered or revised by A Test Lab Techno Corp. personnel only, and shall be noted in the revision section of the document. The client should not use it to claim product endorsement by TAF, or any government agencies. The test results in the report only apply to the tested sample.

Revision History

Rev.	Issue Date	Revisions	Revised By
00	Sep. 04, 2013	Initial Issue	

Verification of Compliance

Issued Date: 09/04/2013

Product Type : Play-Fi Player
Applicant : Phorus, Inc.
Address : 16255 Ventura Boulevard, Suite 310, Encino, United States,
91436
Trade Name : Phorus
Model Number : PS2 Speaker
FCC ID : 2AAWQ-PS2SPEAKER
IC : 11138A-PS2SPEAKER
EUT Rated Voltage : DC 12.0V, 2A
Test Voltage : 120 Vac / 60 Hz
Applicable Standard : FCC 47 CFR PART 15 SUBPART C: Oct., 2012
Canada RSS-210 ISSUE 8: Dec., 2010
Canada RSS-Gen ISSUE 3: Dec., 2010
ANSI C63.4-2009
Test Result : Complied
Performing Lab. : A Test Lab Techno Corp.

No. 140-1, Changan Street, Bade City,
Taoyuan County 334, Taiwan R.O.C.
Tel : +886-3-2710188 / Fax : +886-3-2710190



Taiwan Accreditation Foundation accreditation number: 1330
<http://www.atl-lab.com.tw/e-index.htm>

The above equipment was tested by A Test Lab Techno Corp. The test data, data evaluation, test procedures, and equipment configurations shown in this report were made in accordance with the procedures given in ANSI C63.4: 2009 and the energy emitted by the sample tested as described in this report is in compliance with the requirements of FCC Rules Part 15.207, 15.209, 15.247 .

The test results of this report relate only to the tested sample identified in this report.

Approved By



(Manager)

(Murphy Wang)

Reviewed By



(Testing Engineer)

(Fly Lu)

TABLE OF CONTENTS

1	General Information	6
2	EUT Description.....	7
3	Test Methodology.....	8
	3.1. Mode of Operation.....	8
	3.2. EUT Exercise Software	9
	3.3. Configuration of Test System Details.....	9
	3.4. Test Site Environment.....	10
4	Conducted Emission Measurement.....	11
	4.1. Limit.....	11
	4.2. Test Instruments	11
	4.3. Test Setup	11
	4.4. Test Procedure	12
	4.5. Test Result.....	13
5	Radiated Emission Measurement	15
	5.1. Limit.....	15
	5.2. Test Instruments	15
	5.3. Setup	16
	5.4. Test Procedure	17
	5.5. Test Result.....	19
6	Maximum Conducted Output Power Measurement.....	31
	6.1. Limit.....	31
	6.2. Test Setup	31
	6.3. Test Instruments	31
	6.4. Test Procedure	31
	6.5. Test Result.....	32
7	6dB RF Bandwidth & 99 % Occupied Bandwidth Measurement	38
	7.1. Limit.....	38
	7.2. Test Setup	38
	7.3. Test Instruments	38
	7.4. Test Procedure	39
	7.5. Test Result.....	40
	7.6. Test Graphs	42
8	Maximum Power Density Measurement	49
	8.1. Limit.....	49
	8.2. Test Setup	49
	8.3. Test Instruments	49
	8.4. Test Procedure	49
	8.5. Test Result.....	50
	8.6. Test Graphs	52

9	Out of Band Conducted Emissions Measurement	59
9.1.	Limit.....	59
9.2.	Test Setup	59
9.3.	Test Instruments	59
9.4.	Test Procedure	59
9.5.	Test Graphs	60
10	Band Edges Measurement.....	67
10.1.	Limit.....	67
10.2.	Test Setup	67
10.3.	Test Instruments	67
10.4.	Test Procedure	68
10.5.	Test Result.....	69
11	Antenna Measurement	85
11.1.	Limit.....	85
11.2.	Antenna Connector Construction	85

1 General Information

1.1 Summary of Test Result

Standard		Item	Result	Remark
15.247	RSS-GEN			
15.207	7.2.2	AC Power Conducted Emission	PASS	-----
-----	6	Receiver Radiated Emissions	PASS	-----
Standard		Item	Result	Remark
15.247	RSS-210			
15.247(d)	A8.5	Transmitter Radiated Emissions	PASS	-----
15.247(b)(3)	A8.4	Max. Output Power	PASS	-----
15.247(a)(2)	A8.2 (a)	6dB RF Bandwidth	PASS	-----
15.247(e)	A8.2 (b)	Power Spectral Density	PASS	-----
15.247(c)	A8.5	Out of Band Conducted Spurious Emission	PASS	-----
15.247(d)	A8.5	Band Edge Measurement	PASS	-----
15.247(c)	A8.5	Occupied Bandwidth Measurement	PASS	-----
15.203	-	Antenna Requirement	PASS	-----

The test results of this report relate only to the tested sample(s) identified in this report. Manufacturer or whom it may concern should recognize the pass or fail of the test result.

1.2 Measurement Uncertainty

Conducted Emission

The measurement uncertainty is evaluated as ± 2.24 dB.

Radiated Emission

The measurement uncertainty is evaluated as ± 3.072 dB.

2 EUT Description

Product	Play-Fi Player				
Trade Name	Phorus				
Model No.	PS2 Speaker				
Applicant	Phorus, Inc. 16255 Ventura Boulevard, Suite 310, Encino, United States, 91436				
Manufacturer	Wistron InfoComm (Zhongshan) Corporation Linhai Branch Xiyiwei, Ma'an Cun, Zhongshan Torch Development Zone, Zhongshan City, Guangdong, China				
FCC ID	2AAWQ-PS2SPEAKER				
IC	11138A-PS2SPEAKER				
Frequency Range	IEEE 802.11b / 802.11g / 802.11n 2.4GHz 20MHz: 2412 ~ 2462 MHz IEEE 802.11n 2.4GHz 40MHz: 2422 ~ 2452 MHz IEEE 802.11a / IEEE 802.11n 5 GHz U-NII Band IV: 5745 ~ 5825 MHz				
Modulation Type	IEEE 802.11b:DSSS IEEE 802.11g:DSSS + OFDM IEEE 802.11n 2.4GHz / IEEE 802.11a / IEEE 802.11n 5 GHz U-NII Band IV: OFDM				
Antenna used	Item	Antenna	Type	Band	Max. Gain
	1	Main ANT (ANTL)	PIFA	IEEE 802.11b / 802.11g IEEE 802.11n (2.4GHz) 20MHz / 40MHz	2.78 dBi
				IEEE 802.11a IEEE 802.11n (5GHz) 20MHz / 40MHz U-NII Band IV	3.69 dBi
	2	Aux ANT (ANTR)	PIFA	IEEE 802.11b / 802.11g IEEE 802.11n (2.4GHz) 20MHz / 40MHz	3.37 dBi
IEEE 802.11a IEEE 802.11n (5GHz) 20MHz / 40MHz U-NII Band IV				5.36 dBi	
Antenna Delivery	1*Tx + 1*Rx				
RF Output Power	IEEE 802.11b: 0.050 W / 16.99 dBm IEEE 802.11g: 0.198 W / 22.97 dBm IEEE 802.11n 2.4GHz 20MHz: 0.140 W / 21.46 dBm IEEE 802.11n 2.4GHz 40MHz: 0.129 W / 21.10 dBm IEEE 802.11a U-NII Band IV: 0.098 W / 19.93 dBm IEEE 802.11n U-NII Band IV 20MHz: 0.069 W / 18.38 dBm IEEE 802.11n U-NII Band IV 40MHz: 0.075 W / 18.74 dBm				
EIRP	IEEE 802.11a U-NII Band IV: 0.328 W / 25.16 dBm IEEE 802.11n U-NII Band IV 20MHz: 0.230 W / 23.62 dBm IEEE 802.11n U-NII Band IV 40MHz: 0.248 W / 23.95 dBm				

3 Test Methodology

3.1. Mode of Operation

Decision of Test ATL has verified the construction and function in typical operation. All the test modes were carried out with the EUT in normal operation, which was shown in this test report and defined as:

Test Mode
Mode 1: Normal Operation Mode
Mode 2: IEEE 802.11b Link Mode
Mode 3: IEEE 802.11g Link Mode
Mode 4: IEEE 802.11n 2.4GHz 20MHz Link Mode
Mode 5: IEEE 802.11n 2.4GHz 40MHz Link Mode
Mode 6: IEEE 802.11a U-NII Band IV Link Mode
Mode 7: IEEE 802.11n U-NII Band IV 20MHz Link Mode
Mode 8: IEEE 802.11n U-NII Band IV 40MHz Link Mode
Mode 9: Receiver Mode

Software used to control the EUT for staying in continuous transmitting mode was programmed.

After verification, all tests were carried out with the worst case test modes as shown below except radiated spurious emission below 1GHz and power line conducted emissions below 30MHz, which worst case was in normal link mode only.

IEEE 802.11b mode:

Channel Low (2412MHz), Channel Mid (2437MHz) and Channel High (2462MHz) with 1Mbps data rate were chosen for full testing.

IEEE 802.11g mode:

Channel Low (2412MHz), Channel Mid (2437MHz) and Channel High (2462MHz) with 6Mbps data rate were chosen for full testing.

IEEE 802.11n 2.4GHz 20MHz mode :

Channel Low (2412MHz), Channel Mid (2437MHz) and Channel High (2462MHz) with 6.5Mbps data rate were chosen for full testing.

IEEE 802.11n 2.4GHz 40MHz mode :

Channel Low (2422MHz), Channel Mid (2437MHz) and Channel High (2452MHz) with 13.5Mbps data rate were chosen for full testing.

IEEE 802.11a mode / 5745 ~ 5825MHz:

Channel Low (5745MHz), Channel Mid (5785MHz) and Channel High (5825MHz) with 6Mbps data rate were chosen for full testing.

IEEE 802.11n U-NII Band IV 20MHz mode / 5745 ~ 5825MHz :

Channel Low (5745MHz), Channel Mid (5785MHz) and Channel High (5825MHz) with 6.5Mbps data rate were chosen for full testing.

IEEE 802.11n U-NII Band IV 40MHz mode / 5755 ~ 5795MHz :

Channel Low (5755MHz) and Channel High (5795MHz) with 6.5Mbps data rate were chosen for full testing.

3.2. EUT Exercise Software

1.	Setup the EUT shown on 3.3.
2.	Turn on the power of all equipment.
3.	The EUT LAN port connects to the Notebook and data will communicate between Notebook through EUT.
4.	The EUT will start to operate function.

3.3. Configuration of Test System Details

Conducted Emission

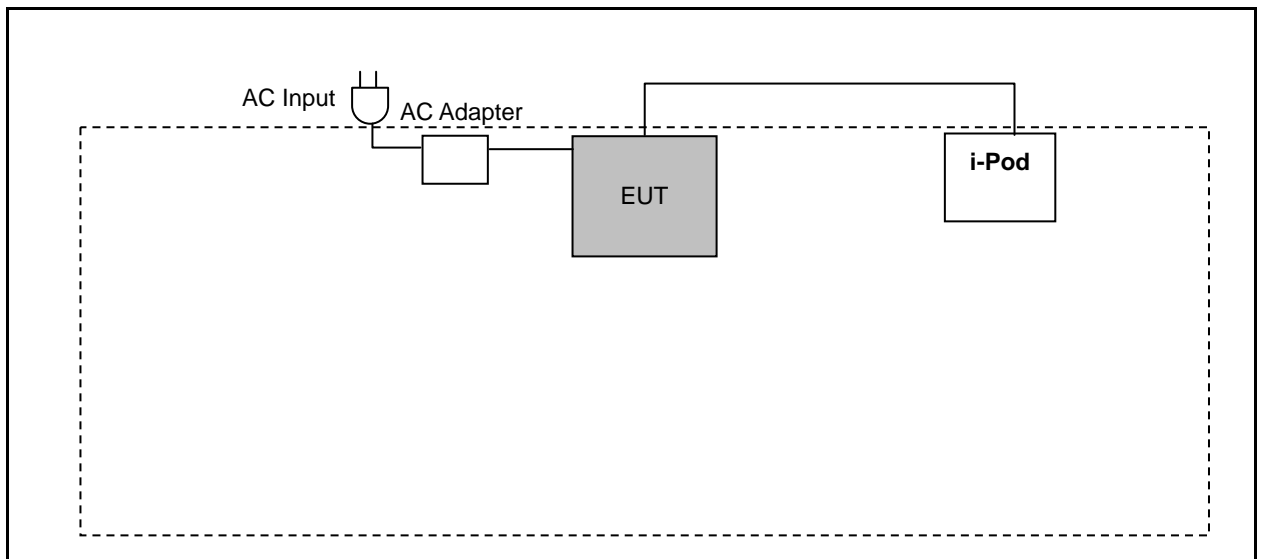

Radiated Emission (Below 1Ghz)

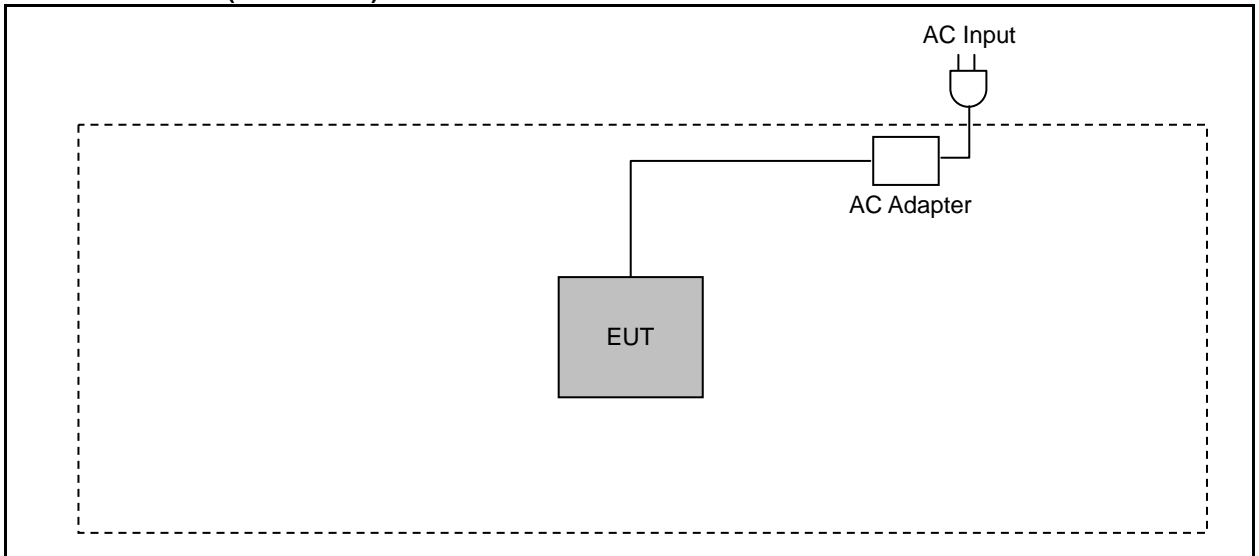

Radiated Emission (Above 1Ghz)

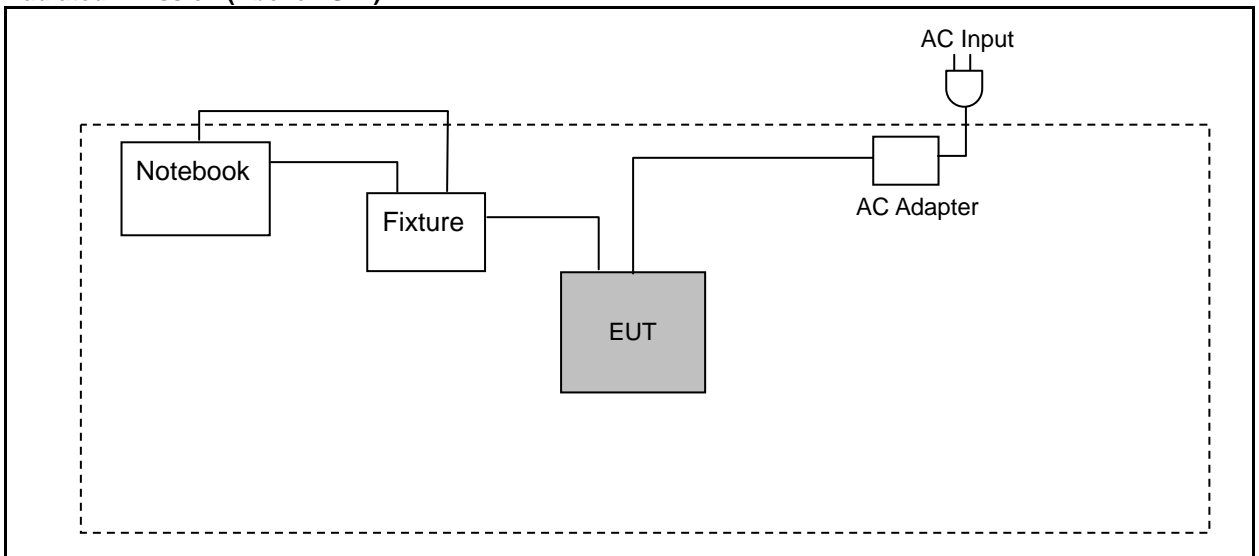

3.4. Test Site Environment

Items	Required (IEC 68-1)	Actual
Temperature (°C)	15-35	26
Humidity (%RH)	25-75	60
Barometric pressure (mbar)	860-1060	950

4 Conducted Emission Measurement

4.1. Limit

Frequency (MHz)	Quasi-peak	Average
0.15 - 0.5	66 to 56	56 to 46
0.50 - 5.0	56	46
5.0 - 30.0	60	50

4.2. Test Instruments

Describe	Manufacturer	Model Number	Serial Number	Cal. Date	Remark
Test Receiver	R&S	ESCI	100367	06/18/2012	(1)
LISN	R&S	ENV216	101040	03/04/2013	(1)
LISN	R&S	ENV216	101041	03/04/2013	(1)
Test Site	ATL	TE02	TE02	N.C.R.	-----

Remark: (1) Calibration period 1 year. (2) Calibration period 2 years. (3) Calibration period 3 years.

Note: N.C.R. = No Calibration Request.

4.3. Test Setup

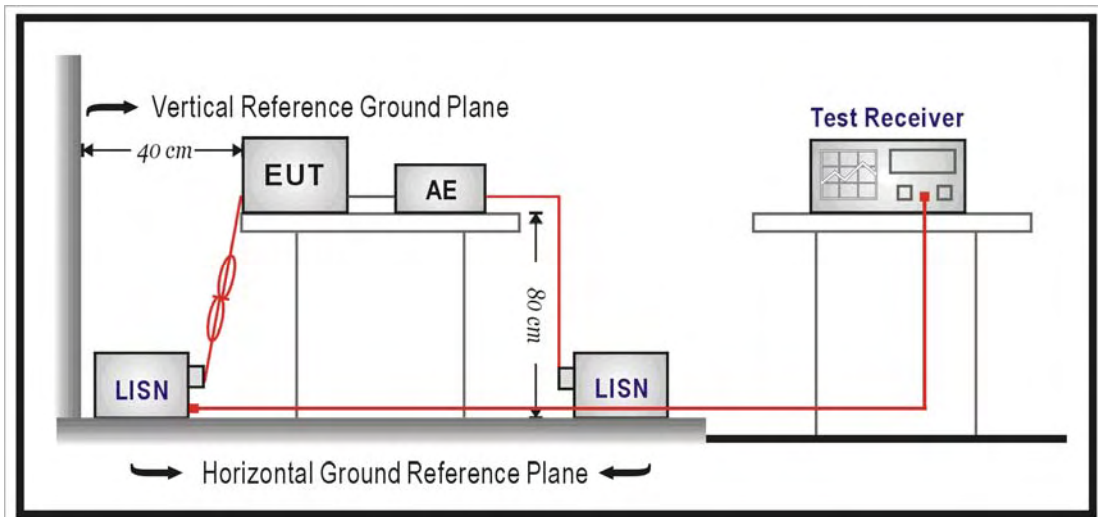

4.4. Test Procedure

The power line conducted emission measurements were performed in a shielded enclosure. The EUT was assembled on a wooden table which is 80 centimeters high, was placed 40 centimeters from the back wall and at least 1 meter from the sidewall.

Power was fed to the EUT from the public utility power grid through a line filter and EMCO Model 3162/2 SH Line Impedance Stabilization Networks (LISN). The LISN housing, measuring instrumentation case, ground plane, etc., were electrically bonded together at the same RF potential. The Spectrum analyzer was connected to the AC line through an isolation transformer. The 50-ohm output of the LISN was connected to the spectrum analyzer directly. Conducted emission levels were in the CISPR quasi-peak detection mode. The analyzer's 6 dB bandwidth was set to 9 KHz. No post-detector video filter was used.

The spectrum was scanned from 150 KHz to 30 MHz. The physical arrangement of the test system and associated cabling was varied (within the scope of arrangements likely to be encountered in actual use) to determine the effect on the unit's emanations in amplitude and frequency. All spurious emission frequencies were observed. The highest emission amplitudes relative to the appropriate limit were measured and have been recorded in paragraph 4.1.

4.5. Test Result

Standard:	FCC Part 15C	Line:	L1
Test item:	Conducted Emission	Power:	AC 120V/60Hz
Model Number:	PS2 Speaker	Temp.(°C)/Hum.(%RH):	26(°C)/60%RH
Mode:	1	Date:	05/03/2013
		Test By:	Fly Lu
Description:			

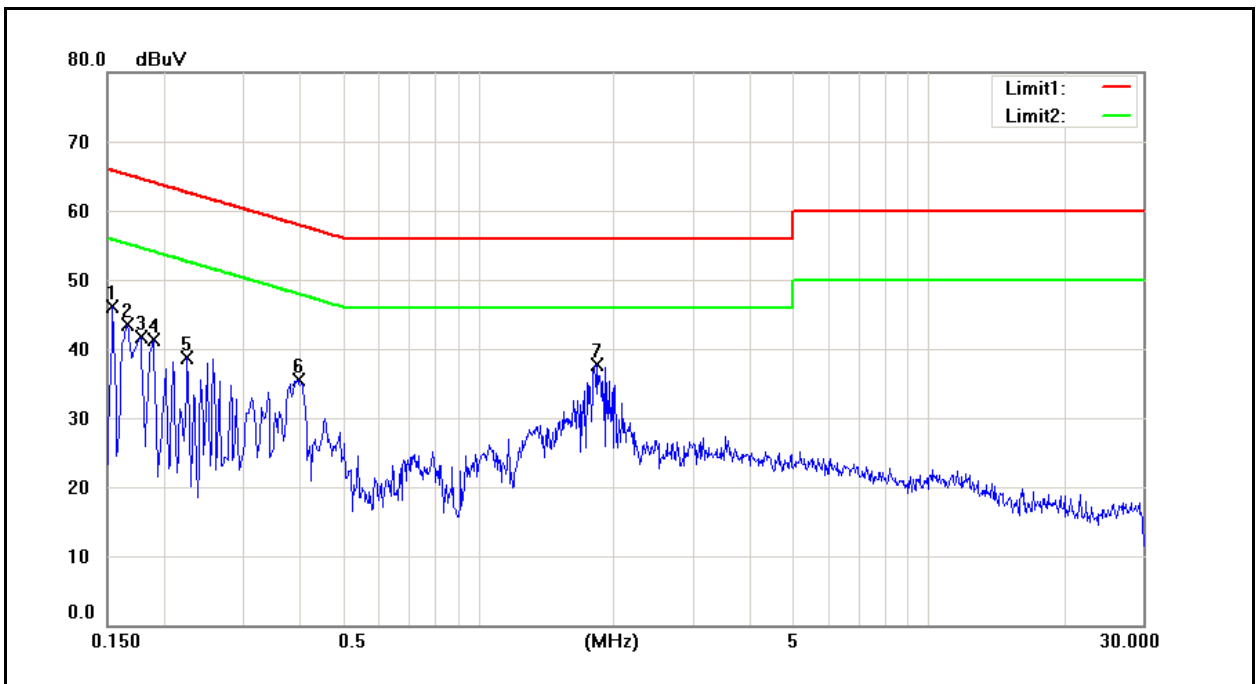

No.	Frequency (MHz)	QP reading (dBuV)	AVG reading (dBuV)	Correction factor (dB)	QP result (dBuV)	AVG result (dBuV)	QP limit (dBuV)	AVG limit (dBuV)	QP margin (dB)	AVG margin (dB)	Remark
1	0.1540	34.04	18.02	9.62	43.66	27.64	65.78	55.78	-22.12	-28.14	Pass
2	0.1660	29.37	7.22	9.62	38.99	16.84	65.16	55.16	-26.17	-38.32	Pass
3	0.1780	30.78	16.61	9.62	40.40	26.23	64.58	54.58	-24.18	-28.35	Pass
4	0.1900	27.11	6.91	9.62	36.73	16.53	64.04	54.04	-27.31	-37.51	Pass
5	0.2260	23.76	7.96	9.62	33.38	17.58	62.60	52.60	-29.22	-35.02	Pass
6	0.3980	25.56	17.96	9.62	35.18	27.58	57.90	47.90	-22.72	-20.32	Pass
7	1.8420	24.54	15.84	9.69	34.23	25.53	56.00	46.00	-21.77	-20.47	Pass

Standard:	FCC Part 15C	Line:	N
Test item:	Conducted Emission	Power:	AC 120V/60Hz
Model Number:	PS2 Speaker	Temp.(°C)/Hum.(%RH):	26(°C)/60%RH
Mode:	1	Date:	05/03/2013
		Test By:	Fly Lu
Description:			

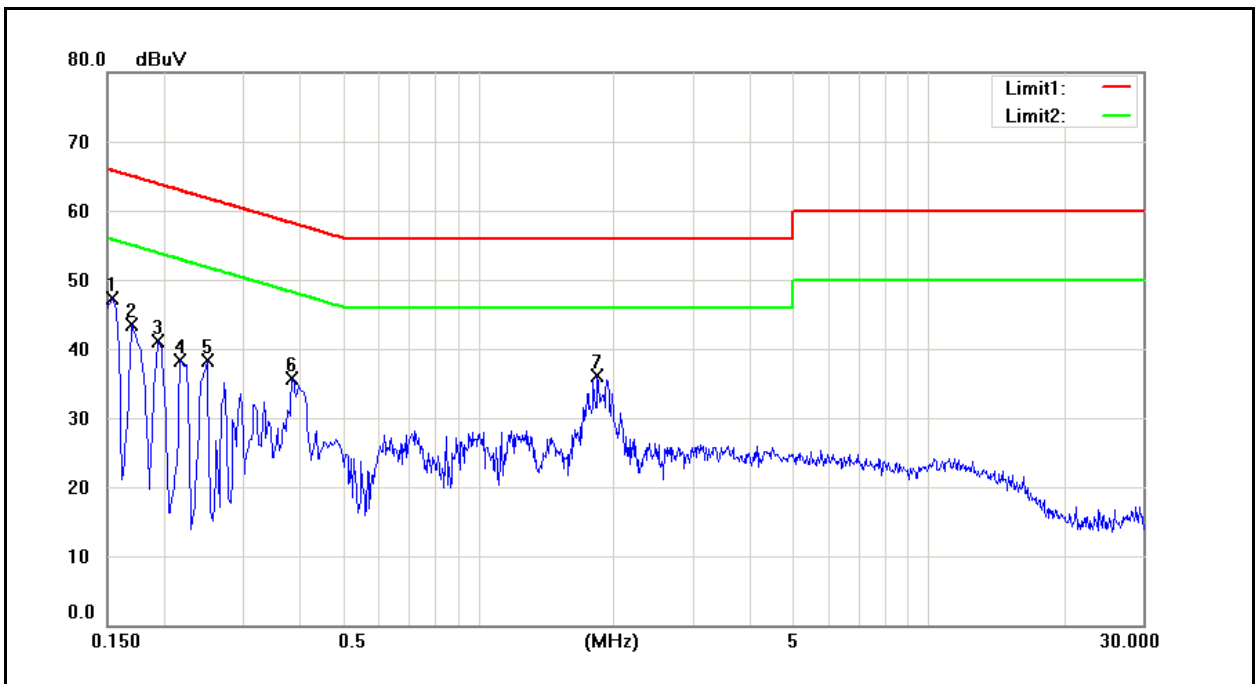

No.	Frequency (MHz)	QP reading (dBuV)	AVG reading (dBuV)	Correction factor (dB)	QP result (dBuV)	AVG result (dBuV)	QP limit (dBuV)	AVG limit (dBuV)	QP margin (dB)	AVG margin (dB)	Remark
1	0.1540	34.13	16.79	9.63	43.76	26.42	65.78	55.78	-22.02	-29.36	Pass
2	0.1700	29.86	9.55	9.63	39.49	19.18	64.96	54.96	-25.47	-35.78	Pass
3	0.1940	26.22	5.69	9.63	35.85	15.32	63.86	53.86	-28.01	-38.54	Pass
4	0.2180	23.23	3.34	9.63	32.86	12.97	62.89	52.89	-30.03	-39.92	Pass
5	0.2500	20.53	3.16	9.63	30.16	12.79	61.76	51.76	-31.60	-38.97	Pass
6	0.3860	23.45	15.43	9.63	33.08	25.06	58.15	48.15	-25.07	-23.09	Pass
7	1.8420	23.21	14.29	9.69	32.90	23.98	56.00	46.00	-23.10	-22.02	Pass

5 Radiated Emission Measurement

5.1. Limit

According to §15.209(a), except as provided elsewhere in this subpart, the emissions from an intentional radiator shall not exceed the field strength levels specified in the following table:

Frequency (MHz)	Field Strength ($\mu\text{V}/\text{m}$ at meter)	Measurement Distance (meters)
0.009 – 0.490	2400 / F (kHz)	300
0.490 – 1.705	24000 / F (kHz)	30
1.705 – 30.0	30	30
30 - 88	100**	3
88-216	150**	3
216-960	200**	3
Above 960	500	3

** Except as provided in paragraph (g), fundamental emissions from intentional radiators operating under this Section shall not be located in the frequency bands 54-72 MHz, 76-88 MHz, 174-216 MHz or 470-806 MHz. However, operation within these frequency bands is permitted under other sections of this Part, e.g., Sections 15.231 and 15.241.

5.2. Test Instruments

3 Meter Chamber					
Equipment	Manufacturer	Model Number	Serial Number	Cal. Date	Remark
RF Pre-selector	Agilent	N9039A	MY46520256	01/16/2012	(2)
Spectrum Analyzer	Agilent	E4446A	MY46180578	01/21/2013	(1)
Pre Amplifier	Agilent	8449B	3008A02237	02/21/2013	(1)
Pre Amplifier	Agilent	8447D	2944A10961	02/21/2013	(1)
Broadband Antenna (30MHz~1GHz)	SCHWARZBECK MESS-ELEKTRONIK	VULB9163	9163-270	06/29/2012	(1)
Horn Antenna (1~18GHz)	SCHWARZBECK MESS-ELEKTRONIK	BBHA9120D	9120D-550	06/15/2012	(1)
Horn Antenna (18~40GHz)	SCHWARZBECK MESS-ELEKTRONIK	BBHA9170	9170-320	06/21/2012	(1)
Loop Antenna	COM-POWER CORPORATION	AL-130	121014	08/14/2012	(3)
Test Site	ATL	TE01	888001	08/28/2012	(1)

Remark: (1) Calibration period 1 year. (2) Calibration period 2 years. (3) Calibration period 3 years.

Note: N.C.R. = No Calibration Request.

5.3. Setup

Below 1GHz

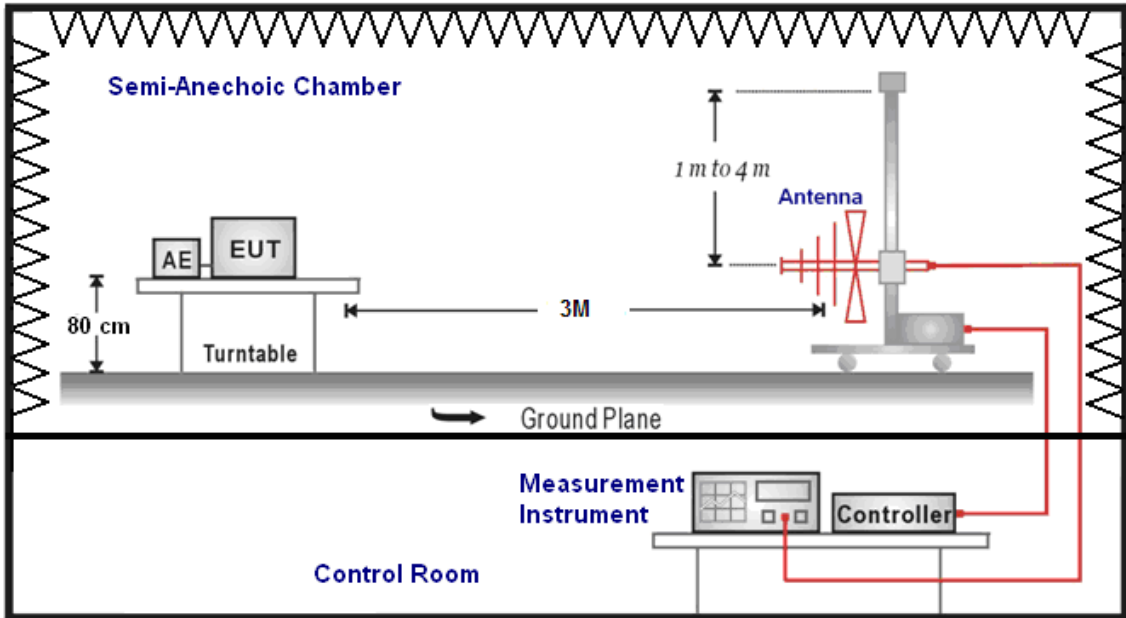

Above 1GHz

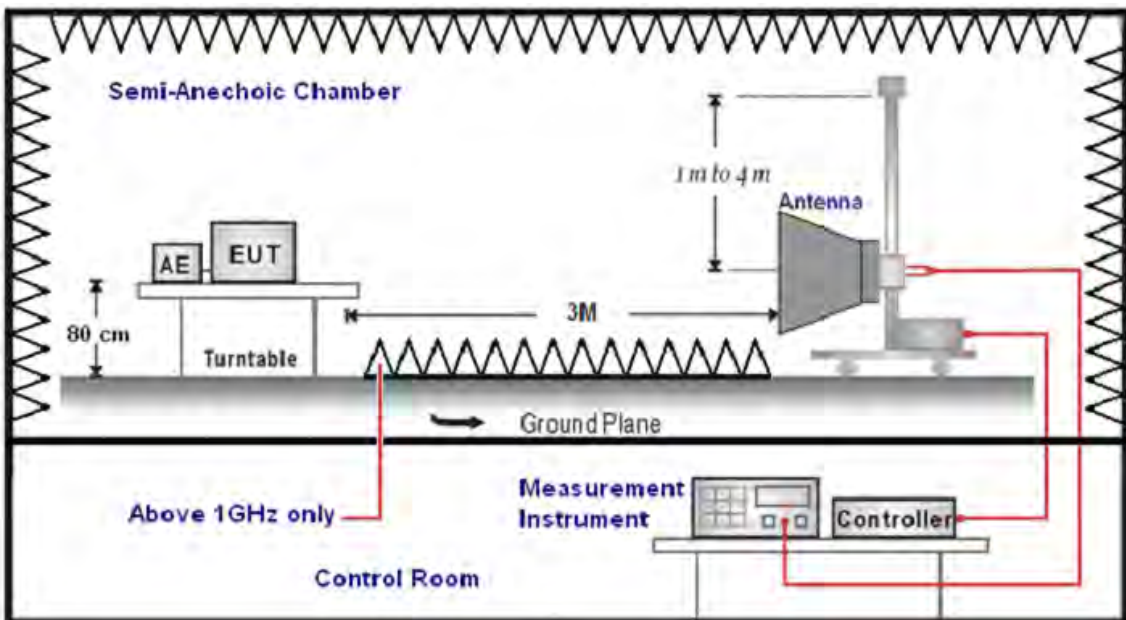

5.4. Test Procedure

Final radiation measurements were made on a three-meter, Semi Anechoic Chamber. The EUT system was placed on a nonconductive turntable which is 0.8 meters height, top surface 1.0 x 1.5 meter. The spectrum was examined from 250 MHz to 2.5 GHz in order to cover the whole spectrum below 10th harmonic which could generate from the EUT. During the test, EUT was set to transmit continuously & Measurements spectrum range from 9 kHz to 26.5 GHz is investigated.

For measurements below 1 GHz the resolution bandwidth is set to 100 kHz for peak detection measurements or 120 kHz for quasi-peak detection measurements. Peak detection is used unless otherwise noted as quasi-peak.

For measurements above 1 GHz the resolution bandwidth is set to 1 MHz, and then the video bandwidth is set to 1 MHz for peak measurements and 10 Hz for average measurements.

A nonconductive material surrounded the EUT to supporting the EUT for standing on three orthogonal planes. At each condition, the EUT was rotated 360 degrees, and the antenna was raised and lowered from one to four meters to find the maximum emission levels. Measurements were taken using both horizontal and vertical antenna polarization.

SCHWARZBECK MESS-ELEKTRONIK Biconilog Antenna (mode VULB9163) at 3 Meter and the SCHWARZBECK Double Ridged Guide Antenna (model BBHA9120D&9170) was used in frequencies 1 – 26.5 GHz at a distance of 1 meter. All test results were extrapolated to equivalent signal at 3 meters utilizing an inverse linear distance extrapolation Factor (20dB/decade).

For testing above 1GHz, the emission level of the EUT in peak mode was 20dB lower than average limit (that means the emission level in peak mode also complies with the limit in average mode), then testing will be stopped and peak values of EUT will be reported, otherwise, the emissions will be measured in average mode again and reported.

Appropriate preamplifiers were used for improving sensitivity and precautions were taken to avoid overloading or desensitizing the spectrum analyzer. No post – detector video filters were used in the test.

The spectrum analyzer's 6 dB bandwidth was set to 1 MHz, and the analyzer was operated in the peak detection mode, for frequencies both below and up 1 GHz. The average levels were obtained by subtracting the duty cycle correction factor from the peak readings.

The following procedures were used to convert the emission levels measured in decibels referenced to 1 microvolt (dBuV) into field intensity in micro volts pre meter (uV/m).

The actual field intensity in decibels referenced to 1 microvolt in to field intensity in micro volts per meter (dBuV/m).

The actual field intensity in referenced to 1 microvolt per meter (dBuV/m) is determined by algebraically adding the measured reading in dBuV, the antenna factor (dB), and cable loss (dB) and Subtracting the gain of preamplifier (dB) is auto calculate in spectrum analyzer.

(1) $\text{Amplitude (dBuV/m)} = \text{FI (dBuV)} + \text{AF (dBuV)} + \text{CL (dBuV)} - \text{Gain (dB)}$

FI= Reading of the field intensity.

AF= Antenna factor.

CL= Cable loss.

P.S Amplitude is auto calculate in spectrum analyzer.

(2) $\text{Actual Amplitude (dBuV/m)} = \text{Amplitude (dBuV)} - \text{Dis(dB)}$

The FCC specified emission limits were calculated according the EUT operating frequency and by following linear interpolation equations:

(a) For fundamental frequency : Transmitter Output < +30dBm

(b) For spurious frequency : Spurious emission limits = fundamental emission limit /10

Data of measurement within this frequency range without mark in the table above means the reading of emissions are attenuated more than 20dB below the permissible limits or the field strength is too small to be measured.

5.5. Test Result

Below 1GHz

Standard:	FCC Part 15C	Test Distance:	3m
Test item:	Radiated Emission	Power:	AC 120V/60Hz
Model Number:	PS2 Speaker	Temp.(°C)/Hum.(%RH):	26(°C)/60%RH
Mode:	1	Date:	05/03/2013
		Test By:	Fly Lu

Frequency (MHz)	Reading (dBuV)	Correct Factor (dB/m)	Result (dBuV/m)	Limit (dBuV/m)	Margin (dB)	Remark	Ant.Polar. H / V
120.0000	45.99	-16.06	29.93	43.50	-13.57	QP	H
240.0000	37.02	-12.25	24.77	46.00	-21.23	QP	H
399.5000	42.34	-8.60	33.74	46.00	-12.26	QP	H
587.0000	27.20	-5.43	21.77	46.00	-24.23	QP	H
799.0000	30.71	-1.57	29.14	46.00	-16.86	QP	H
936.0000	28.54	0.88	29.42	46.00	-16.58	QP	H
120.0000	43.09	-16.06	27.03	43.50	-16.47	QP	V
205.5000	42.75	-13.99	28.76	43.50	-14.74	QP	V
360.0000	40.28	-8.73	31.55	46.00	-14.45	QP	V
501.0000	39.70	-6.79	32.91	46.00	-13.09	QP	V
673.0000	30.47	-3.90	26.57	46.00	-19.43	QP	V
796.5000	33.38	-1.62	31.76	46.00	-14.24	QP	V

Note: No emission found between lowest internal used/generated frequency to 30MHz (9kHz~30MHz).

Above 1GHz

Standard:	FCC Part 15C			Test Distance:	3m		
Test item:	Radiated Emission			Power:	AC 120V/60Hz		
Model Number:	PS2 Speaker			Temp.(°C)/Hum.(%RH):	26(°C)/60%RH		
Mode:	2			Date:	04/30/2013		
Frequency:	2412MHz			Test By:	Fly Lu		
Frequency (MHz)	Reading (dBuV)	Correct Factor (dB/m)	Result (dBuV/m)	Limit (dBuV/m)	Margin (dB)	Remark	Ant.Polar. H / V
2869.000	38.37	5.57	43.94	74.00	-30.06	peak	H
4521.000	36.15	10.93	47.08	74.00	-26.92	peak	H
6005.000	33.52	15.90	49.42	74.00	-24.58	peak	H
2925.000	37.11	5.73	42.84	74.00	-31.16	peak	V
4500.000	35.35	10.88	46.23	74.00	-27.77	peak	V
5872.000	34.27	15.49	49.76	74.00	-24.24	peak	V

Standard:	FCC Part 15C			Test Distance:	3m		
Test item:	Radiated Emission			Power:	AC 120V/60Hz		
Model Number:	PS2 Speaker			Temp.(°C)/Hum.(%RH):	26(°C)/60%RH		
Mode:	2			Date:	04/30/2013		
Frequency:	2437MHz			Test By:	Fly Lu		
Frequency (MHz)	Reading (dBuV)	Correct Factor (dB/m)	Result (dBuV/m)	Limit (dBuV/m)	Margin (dB)	Remark	Ant.Polar. H / V
3065.000	36.92	6.06	42.98	74.00	-31.02	peak	H
4874.000	42.14	11.84	53.98	74.00	-20.02	peak	H
4874.000	41.35	11.84	53.19	54.00	-0.81	AVG	H
6194.000	32.85	16.47	49.32	74.00	-24.68	peak	H
3002.000	38.72	5.91	44.63	74.00	-29.37	peak	V
4465.000	35.78	10.75	46.53	74.00	-27.47	peak	V
6005.000	33.96	15.90	49.86	74.00	-24.14	peak	V

Standard:	FCC Part 15C	Test Distance:	3m
Test item:	Radiated Emission	Power:	AC 120V/60Hz
Model Number:	PS2 Speaker	Temp.(°C)/Hum.(%RH):	26(°C)/60%RH
Mode:	2	Date:	04/30/2013
Frequency:	2462MHz	Test By:	Fly Lu

Frequency (MHz)	Reading (dBuV)	Correct Factor (dB/m)	Result (dBuV/m)	Limit (dBuV/m)	Margin (dB)	Remark	Ant.Polar. H / V
2953.000	38.43	5.79	44.22	74.00	-29.78	peak	H
4924.000	39.34	11.97	51.31	74.00	-22.69	peak	H
6047.000	33.68	16.03	49.71	74.00	-24.29	peak	H
2995.000	38.26	5.90	44.16	74.00	-29.84	peak	V
4493.000	35.37	10.86	46.23	74.00	-27.77	peak	V
6082.000	33.49	16.13	49.62	74.00	-24.38	peak	V

Standard:	FCC Part 15C	Test Distance:	3m
Test item:	Radiated Emission	Power:	AC 120V/60Hz
Model Number:	PS2 Speaker	Temp.(°C)/Hum.(%RH):	26(°C)/60%RH
Mode:	3	Date:	04/30/2013
Frequency:	2412MHz	Test By:	Fly Lu

Frequency (MHz)	Reading (dBuV)	Correct Factor (dB/m)	Result (dBuV/m)	Limit (dBuV/m)	Margin (dB)	Remark	Ant.Polar. H / V
3002.000	38.20	5.91	44.11	74.00	-29.89	peak	H
4542.000	36.47	10.99	47.46	74.00	-26.54	peak	H
6215.000	34.09	16.54	50.63	74.00	-23.37	peak	H
3002.000	38.79	5.91	44.70	74.00	-29.30	peak	V
4493.000	35.16	10.86	46.02	74.00	-27.98	peak	V
5998.000	33.66	15.88	49.54	74.00	-24.46	peak	V

Standard:	FCC Part 15C		Test Distance:	3m			
Test item:	Radiated Emission		Power:	AC 120V/60Hz			
Model Number:	PS2 Speaker		Temp.(°C)/Hum.(%RH):	26(°C)/60%RH			
Mode:	3		Date:	04/30/2013			
Frequency:	2437MHz		Test By:	Fly Lu			
Frequency (MHz)	Reading (dBuV)	Correct Factor (dB/m)	Result (dBuV/m)	Limit (dBuV/m)	Margin (dB)	Remark	Ant.Polar. H / V
3079.000	38.88	6.08	44.96	74.00	-29.04	peak	H
4874.000	39.63	11.84	51.47	74.00	-22.53	peak	H
6061.000	33.76	16.07	49.83	74.00	-24.17	peak	H
3072.000	38.33	6.07	44.40	74.00	-29.60	peak	V
4472.000	36.57	10.79	47.36	74.00	-26.64	peak	V
5984.000	34.78	15.83	50.61	74.00	-23.39	peak	V

Standard:	FCC Part 15C		Test Distance:	3m			
Test item:	Radiated Emission		Power:	AC 120V/60Hz			
Model Number:	PS2 Speaker		Temp.(°C)/Hum.(%RH):	26(°C)/60%RH			
Mode:	3		Date:	04/30/2013			
Frequency:	2462MHz		Test By:	Fly Lu			
Frequency (MHz)	Reading (dBuV)	Correct Factor (dB/m)	Result (dBuV/m)	Limit (dBuV/m)	Margin (dB)	Remark	Ant.Polar. H / V
2939.000	39.57	5.75	45.32	74.00	-28.68	peak	H
4535.000	35.95	10.97	46.92	74.00	-27.08	peak	H
5683.000	35.03	14.91	49.94	74.00	-24.06	peak	H
2890.000	36.89	5.63	42.52	74.00	-31.48	peak	V
4542.000	34.65	10.99	45.64	74.00	-28.36	peak	V
6166.000	33.32	16.39	49.71	74.00	-24.29	peak	V

Standard:	FCC Part 15C			Test Distance:	3m		
Test item:	Radiated Emission			Power:	AC 120V/60Hz		
Model Number:	PS2 Speaker			Temp.(°C)/Hum.(%RH):	26(°C)/60%RH		
Mode:	4			Date:	04/30/2013		
Frequency:	2412MHz			Test By:	Fly Lu		
Frequency (MHz)	Reading (dBuV)	Correct Factor (dB/m)	Result (dBuV/m)	Limit (dBuV/m)	Margin (dB)	Remark	Ant.Polar. H / V
3051.000	38.82	6.02	44.84	74.00	-29.16	peak	H
4493.000	36.68	10.86	47.54	74.00	-26.46	peak	H
5921.000	34.71	15.63	50.34	74.00	-23.66	peak	H
2981.000	39.67	5.86	45.53	74.00	-28.47	peak	V
4479.000	36.94	10.81	47.75	74.00	-26.25	peak	V
5914.000	35.28	15.61	50.89	74.00	-23.11	peak	V

Standard:	FCC Part 15C			Test Distance:	3m		
Test item:	Radiated Emission			Power:	AC 120V/60Hz		
Model Number:	PS2 Speaker			Temp.(°C)/Hum.(%RH):	26(°C)/60%RH		
Mode:	4			Date:	04/30/2013		
Frequency:	2437MHz			Test By:	Fly Lu		
Frequency (MHz)	Reading (dBuV)	Correct Factor (dB/m)	Result (dBuV/m)	Limit (dBuV/m)	Margin (dB)	Remark	Ant.Polar. H / V
3044.000	37.51	6.00	43.51	74.00	-30.49	peak	H
4871.000	39.66	11.83	51.49	74.00	-22.51	peak	H
5998.000	34.49	15.88	50.37	74.00	-23.63	peak	H
2953.000	38.04	5.79	43.83	74.00	-30.17	peak	V
4451.000	36.12	10.71	46.83	74.00	-27.17	peak	V
5991.000	33.98	15.85	49.83	74.00	-24.17	peak	V

Standard:	FCC Part 15C			Test Distance:	3m		
Test item:	Radiated Emission			Power:	AC 120V/60Hz		
Model Number:	PS2 Speaker			Temp.(°C)/Hum.(%RH):	26(°C)/60%RH		
Mode:	4			Date:	04/30/2013		
Frequency:	2462MHz			Test By:	Fly Lu		
Frequency (MHz)	Reading (dBuV)	Correct Factor (dB/m)	Result (dBuV/m)	Limit (dBuV/m)	Margin (dB)	Remark	Ant.Polar. H / V
3009.000	37.97	5.93	43.90	74.00	-30.10	peak	H
4924.000	38.06	11.97	50.03	74.00	-23.97	peak	H
6257.000	32.43	16.66	49.09	74.00	-24.91	peak	H
3023.000	37.05	5.96	43.01	74.00	-30.99	peak	V
4563.000	35.31	11.05	46.36	74.00	-27.64	peak	V
6110.000	32.64	16.21	48.85	74.00	-25.15	peak	V

Standard:	FCC Part 15C			Test Distance:	3m		
Test item:	Radiated Emission			Power:	AC 120V/60Hz		
Model Number:	PS2 Speaker			Temp.(°C)/Hum.(%RH):	26(°C)/60%RH		
Mode:	5			Date:	04/30/2013		
Frequency:	2422MHz			Test By:	Fly Lu		
Frequency (MHz)	Reading (dBuV)	Correct Factor (dB/m)	Result (dBuV/m)	Limit (dBuV/m)	Margin (dB)	Remark	Ant.Polar. H / V
2890.000	37.58	5.63	43.21	74.00	-30.79	peak	H
4844.000	39.66	11.77	51.43	74.00	-22.57	peak	H
6145.000	33.30	16.32	49.62	74.00	-24.38	peak	H
3016.000	38.25	5.95	44.20	74.00	-29.80	peak	V
4563.000	35.86	11.05	46.91	74.00	-27.09	peak	V
5921.000	34.34	15.63	49.97	74.00	-24.03	peak	V

Standard:	FCC Part 15C	Test Distance:	3m
Test item:	Radiated Emission	Power:	AC 120V/60Hz
Model Number:	PS2 Speaker	Temp.(°C)/Hum.(%RH):	26(°C)/60%RH
Mode:	5	Date:	04/30/2013
Frequency:	2437MHz	Test By:	Fly Lu

Frequency (MHz)	Reading (dBuV)	Correct Factor (dB/m)	Result (dBuV/m)	Limit (dBuV/m)	Margin (dB)	Remark	Ant.Polar. H / V
2974.000	37.51	5.84	43.35	74.00	-30.65	peak	H
4874.000	38.04	11.84	49.88	74.00	-24.12	peak	H
6229.000	33.53	16.58	50.11	74.00	-23.89	peak	H
3037.000	37.92	5.99	43.91	74.00	-30.09	peak	V
4514.000	35.45	10.92	46.37	74.00	-27.63	peak	V
6250.000	33.95	16.64	50.59	74.00	-23.41	peak	V

Standard:	FCC Part 15C	Test Distance:	3m
Test item:	Radiated Emission	Power:	AC 120V/60Hz
Model Number:	PS2 Speaker	Temp.(°C)/Hum.(%RH):	26(°C)/60%RH
Mode:	5	Date:	04/30/2013
Frequency:	2452MHz	Test By:	Fly Lu

Frequency (MHz)	Reading (dBuV)	Correct Factor (dB/m)	Result (dBuV/m)	Limit (dBuV/m)	Margin (dB)	Remark	Ant.Polar. H / V
3149.000	38.13	6.24	44.37	74.00	-29.63	peak	H
4535.000	36.33	10.97	47.30	74.00	-26.70	peak	H
6201.000	33.89	16.49	50.38	74.00	-23.62	peak	H
2967.000	37.88	5.82	43.70	74.00	-30.30	peak	V
4591.000	35.93	11.11	47.04	74.00	-26.96	peak	V
6040.000	34.59	16.00	50.59	74.00	-23.41	peak	V

Standard:	FCC Part 15C		Test Distance:	3m			
Test item:	Radiated Emission		Power:	AC 120V/60Hz			
Model Number:	PS2 Speaker		Temp.(°C)/Hum.(%RH):	26(°C)/60%RH			
Mode:	6		Date:	05/01/2013			
Frequency:	5745MHz		Test By:	Fly Lu			
Frequency (MHz)	Reading (dBuV)	Correct Factor (dB/m)	Result (dBuV/m)	Limit (dBuV/m)	Margin (dB)	Remark	Ant.Polar. H / V
2533.000	38.99	4.71	43.70	74.00	-30.30	peak	H
4486.000	36.51	10.83	47.34	74.00	-26.66	peak	H
6110.000	34.64	16.21	50.85	74.00	-23.15	peak	H
2631.000	36.74	4.96	41.70	74.00	-32.30	peak	V
4458.000	34.05	10.73	44.78	74.00	-29.22	peak	V
6026.000	33.20	15.95	49.15	74.00	-24.85	peak	V

Standard:	FCC Part 15C		Test Distance:	3m			
Test item:	Radiated Emission		Power:	AC 120V/60Hz			
Model Number:	PS2 Speaker		Temp.(°C)/Hum.(%RH):	26(°C)/60%RH			
Mode:	6		Date:	05/01/2013			
Frequency:	5785MHz		Test By:	Fly Lu			
Frequency (MHz)	Reading (dBuV)	Correct Factor (dB/m)	Result (dBuV/m)	Limit (dBuV/m)	Margin (dB)	Remark	Ant.Polar. H / V
2603.000	36.67	4.89	41.56	74.00	-32.44	peak	H
4549.000	34.68	11.01	45.69	74.00	-28.31	peak	H
6495.000	33.34	17.39	50.73	74.00	-23.27	peak	H
2694.000	37.69	5.12	42.81	74.00	-31.19	peak	V
4535.000	33.51	10.97	44.48	74.00	-29.52	peak	V
6467.000	33.82	17.31	51.13	74.00	-22.87	peak	V

Standard:	FCC Part 15C			Test Distance:	3m		
Test item:	Radiated Emission			Power:	AC 120V/60Hz		
Model Number:	PS2 Speaker			Temp.(°C)/Hum.(%RH):	26(°C)/60%RH		
Mode:	6			Date:	05/01/2013		
Frequency:	5825MHz			Test By:	Fly Lu		
Frequency (MHz)	Reading (dBuV)	Correct Factor (dB/m)	Result (dBuV/m)	Limit (dBuV/m)	Margin (dB)	Remark	Ant.Polar. H / V
2715.000	37.29	5.17	42.46	74.00	-31.54	peak	H
4535.000	34.58	10.97	45.55	74.00	-28.45	peak	H
6390.000	33.70	17.08	50.78	74.00	-23.22	peak	H
2589.000	36.32	4.85	41.17	74.00	-32.83	peak	V
4493.000	35.12	10.86	45.98	74.00	-28.02	peak	V
6257.000	33.24	16.66	49.90	74.00	-24.10	peak	V

Standard:	FCC Part 15C			Test Distance:	3m		
Test item:	Radiated Emission			Power:	AC 120V/60Hz		
Model Number:	PS2 Speaker			Temp.(°C)/Hum.(%RH):	26(°C)/60%RH		
Mode:	7			Date:	05/01/2013		
Frequency:	5745MHz			Test By:	Fly Lu		
Frequency (MHz)	Reading (dBuV)	Correct Factor (dB/m)	Result (dBuV/m)	Limit (dBuV/m)	Margin (dB)	Remark	Ant.Polar. H / V
2533.000	37.83	4.71	42.54	74.00	-31.46	peak	H
4521.000	34.91	10.93	45.84	74.00	-28.16	peak	H
6257.000	33.55	16.66	50.21	74.00	-23.79	peak	H
2673.000	37.73	5.07	42.80	74.00	-31.20	peak	V
4458.000	34.43	10.73	45.16	74.00	-28.84	peak	V
6019.000	32.97	15.94	48.91	74.00	-25.09	peak	V

Standard:	FCC Part 15C			Test Distance:	3m		
Test item:	Radiated Emission			Power:	AC 120V/60Hz		
Model Number:	PS2 Speaker			Temp.(°C)/Hum.(%RH):	26(°C)/60%RH		
Mode:	7			Date:	05/01/2013		
Frequency:	5785MHz			Test By:	Fly Lu		
Frequency (MHz)	Reading (dBuV)	Correct Factor (dB/m)	Result (dBuV/m)	Limit (dBuV/m)	Margin (dB)	Remark	Ant.Polar. H / V
2757.000	37.29	5.28	42.57	74.00	-31.43	peak	H
4521.000	35.03	10.93	45.96	74.00	-28.04	peak	H
6257.000	33.81	16.66	50.47	74.00	-23.53	peak	H
2666.000	37.15	5.05	42.20	74.00	-31.80	peak	V
4535.000	34.58	10.97	45.55	74.00	-28.45	peak	V
6362.000	33.60	16.99	50.59	74.00	-23.41	peak	V

Standard:	FCC Part 15C			Test Distance:	3m		
Test item:	Radiated Emission			Power:	AC 120V/60Hz		
Model Number:	PS2 Speaker			Temp.(°C)/Hum.(%RH):	26(°C)/60%RH		
Mode:	7			Date:	05/01/2013		
Frequency:	5825MHz			Test By:	Fly Lu		
Frequency (MHz)	Reading (dBuV)	Correct Factor (dB/m)	Result (dBuV/m)	Limit (dBuV/m)	Margin (dB)	Remark	Ant.Polar. H / V
2883.000	37.60	5.61	43.21	74.00	-30.79	peak	H
4626.000	35.99	11.20	47.19	74.00	-26.81	peak	H
6369.000	33.02	17.00	50.02	74.00	-23.98	peak	H
3023.000	36.00	5.96	41.96	74.00	-32.04	peak	V
4542.000	34.40	10.99	45.39	74.00	-28.61	peak	V
6306.000	32.80	16.82	49.62	74.00	-24.38	peak	V

Standard:	FCC Part 15C			Test Distance:	3m		
Test item:	Radiated Emission			Power:	AC 120V/60Hz		
Model Number:	PS2 Speaker			Temp.(°C)/Hum.(%RH):	26(°C)/60%RH		
Mode:	8			Date:	05/01/2013		
Frequency:	5755MHz			Test By:	Fly Lu		
Frequency (MHz)	Reading (dBuV)	Correct Factor (dB/m)	Result (dBuV/m)	Limit (dBuV/m)	Margin (dB)	Remark	Ant.Polar. H / V
2687.000	37.58	5.11	42.69	74.00	-31.31	peak	H
4535.000	33.95	10.97	44.92	74.00	-29.08	peak	H
6397.000	33.25	17.10	50.35	74.00	-23.65	peak	H
2757.000	37.52	5.28	42.80	74.00	-31.20	peak	V
4479.000	33.93	10.81	44.74	74.00	-29.26	peak	V
6397.000	33.31	17.10	50.41	74.00	-23.59	peak	V

Standard:	FCC Part 15C			Test Distance:	3m		
Test item:	Radiated Emission			Power:	AC 120V/60Hz		
Model Number:	PS2 Speaker			Temp.(°C)/Hum.(%RH):	26(°C)/60%RH		
Mode:	8			Date:	05/01/2013		
Frequency:	5795MHz			Test By:	Fly Lu		
Frequency (MHz)	Reading (dBuV)	Correct Factor (dB/m)	Result (dBuV/m)	Limit (dBuV/m)	Margin (dB)	Remark	Ant.Polar. H / V
2631.000	38.30	4.96	43.26	74.00	-30.74	peak	H
4535.000	34.56	10.97	45.53	74.00	-28.47	peak	H
6418.000	32.94	17.16	50.10	74.00	-23.90	peak	H
2715.000	37.16	5.17	42.33	74.00	-31.67	peak	V
4542.000	35.22	10.99	46.21	74.00	-27.79	peak	V
6222.000	33.83	16.56	50.39	74.00	-23.61	peak	V

Standard:	RSS-Gen	Test Distance:	3m
Test item:	Radiated Emission	Power:	AC 120V/60Hz
Model Number:	PS2 Speaker	Temp.(°C)/Hum.(%RH):	26(°C)/60%RH
Mode:	9	Date:	04/30/2013
Modulation:	IEEE 802.11b	Test By:	Fly Lu
Frequency:	2437MHz		

Frequency (MHz)	Reading (dBuV)	Correct Factor (dB/m)	Result (dBuV/)	Peak Limit (dBuV/m)	AVG. Limit (dBuV/m)	Margin (dB)	Remark	Ant.Pola H / V
2974.000	37.65	5.84	43.49	74.00	54.00	-30.51	peak	H
4521.000	35.13	10.93	46.06	74.00	54.00	-27.94	peak	H
6159.000	33.73	16.37	50.10	74.00	54.00	-23.90	peak	H
3058.000	37.99	6.04	44.03	74.00	54.00	-29.97	peak	V
4535.000	34.77	10.97	45.74	74.00	54.00	-28.26	peak	V
6145.000	32.95	16.32	49.27	74.00	54.00	-24.73	peak	V

Standard:	RSS-Gen	Test Distance:	3m
Test item:	Radiated Emission	Power:	AC 120V/60Hz
Model Number:	PS2 Speaker	Temp.(°C)/Hum.(%RH):	26(°C)/60%RH
Mode:	9	Date:	05/16/2013
Modulation:	IEEE 802.11a	Test By:	Fly Lu
Frequency:	5745MHz		

Frequency (MHz)	Reading (dBuV)	Correct Factor (dB/m)	Result (dBuV/)	Peak Limit (dBuV/m)	AVG. Limit (dBuV/m)	Margin (dB)	Remark	Ant.Pola H / V
3107.000	36.08	6.14	42.22	74.00	54.00	-31.78	peak	H
4535.000	32.25	10.97	43.22	74.00	54.00	-30.78	peak	H
6586.000	32.25	17.84	50.09	74.00	54.00	-23.91	peak	H
3163.000	35.42	6.27	41.69	74.00	54.00	-32.31	peak	V
4563.000	32.95	11.05	44.00	74.00	54.00	-30.00	peak	V
6411.000	33.03	17.14	50.17	74.00	54.00	-23.83	peak	V

6 Maximum Conducted Output Power Measurement

6.1. Limit

For systems using digital modulation in the 2400-2483.5MHz, the limit for peak output power is 30dBm.

6.2. Test Setup

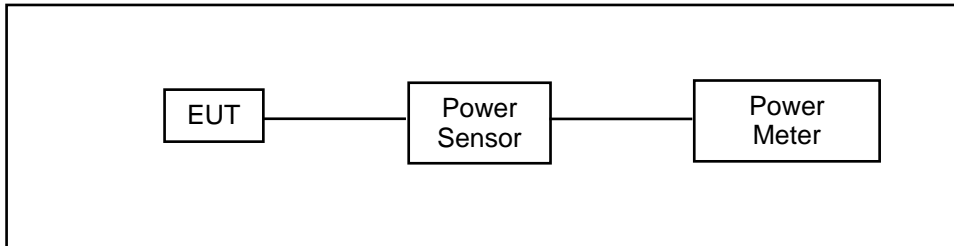

6.3. Test Instruments

Equipment	Manufacturer	Model Number	Serial Number	Cal. Date	Remark
Single Channel PK Power Sensor	Agilent	N1911A	MY45101619	12/19/2012	(1)
Wideband Power Meter	Agilent	N1921A	MY45241957	12/19/2012	(1)
Test Site	ATL	TE05	TE05	N.C.R.	-----

Remark: (1) Calibration period 1 year. (2) Calibration period 2 years. (3) Calibration period 3 years.

Note: N.C.R. = No Calibration Request.

6.4. Test Procedure

The tests below are run with the EUT's transmitter set at high power in TX mode. The EUT is needed to force selection of output power level and channel number. While testing, EUT was set to transmit continuously. Remove the Subjective device's antenna and connect the RF output port to power sensor. The maximum peak output power shall not exceed 1 watt.

Use a direct connection between the antenna port of transmitter and the power sensor, for prevent the power sensor input attenuation 40-50 dB. Set the RBW Bandwidth of the emission or use a channel power meter mode.

For antennas with gains of 6 dBi or less, maximum allowed transmitter output is 1 watt (+30 dBm). For antennas with gains greater than 6 dBi, transmitter output level must be decreased by an amount equal to $(\text{GAIN} - 6)/3$ dBm.

The antenna port of the EUT was connected to the input of a power sensor. Power was read directly and cable loss correction was added to the reading to obtain power at the EUT antenna terminals.

6.5. Test Result

Model Number	PS2 Speaker										
Test Item	Maximum Conducted Output Power										
Test Mode	Mode 2: IEEE 802.11b Link Mode										
Date of Test	04/30/2013							Test Site		TE05	
Frequency (MHz)	Data Rate	Average Power				Peak Power				Limit (dBm)	
		AN TL		AN TR		AN TL		AN TR			
		(dBm)	(W)	(dBm)	(W)	(dBm)	(W)	(dBm)	(W)		
2412	1 M	14.40	0.028	14.30	0.027	16.99	0.050	16.86	0.049	< 30	
2437		13.71	0.023	13.61	0.023	16.38	0.043	16.25	0.042	< 30	
2462		13.75	0.024	13.65	0.023	16.45	0.044	16.32	0.043	< 30	
2437	2 M	13.66	0.023	13.57	0.023	16.31	0.043	16.18	0.041	< 30	
2437	5.5 M	13.62	0.023	13.55	0.023	16.27	0.042	16.14	0.041	< 30	
2437	11 M	13.59	0.023	13.53	0.023	16.22	0.042	16.09	0.041	< 30	

Model Number	PS2 Speaker										
Test Item	Maximum Conducted Output Power										
Test Mode	Mode 3: IEEE 802.11g Link Mode										
Date of Test	04/30/2013							Test Site		TE05	
Frequency (MHz)	Data Rate	Average Power				Peak Power				Limit (dBm)	
		AN TL		AN TR		AN TL		AN TR			
		(dBm)	(W)	(dBm)	(W)	(dBm)	(W)	(dBm)	(W)		
2412	6 M	13.06	0.020	12.93	0.020	22.73	0.187	22.59	0.182	< 30	
2437		13.73	0.024	13.60	0.023	22.97	0.198	22.83	0.192	< 30	
2462		13.37	0.022	13.24	0.021	22.81	0.191	22.67	0.185	< 30	
2437	9 M	13.69	0.023	13.56	0.023	22.87	0.194	22.73	0.187	< 30	
2437	12 M	13.63	0.023	13.50	0.022	22.72	0.187	22.58	0.181	< 30	
2437	18 M	13.57	0.023	13.44	0.022	22.57	0.181	22.43	0.175	< 30	
2437	24 M	13.51	0.022	13.38	0.022	22.42	0.175	22.28	0.169	< 30	
2437	36 M	13.43	0.022	13.30	0.021	22.22	0.167	22.08	0.161	< 30	
2437	48 M	13.35	0.022	13.22	0.021	22.02	0.159	21.88	0.154	< 30	
2437	54 M	13.31	0.021	13.18	0.021	21.92	0.156	21.78	0.151	< 30	

Model Number	PS2 Speaker										
Test Item	Maximum Conducted Output Power										
Test Mode	Mode 4: IEEE 802.11n 2.4GHz 20MHz Link Mode										
Date of Test	04/30/2013							Test Site		TE05	
Frequency (MHz)	Data Rate	Average Power				Peak Power				Limit (dBm)	
		ANTL		ANTR		ANTL		ANTR			
		(dBm)	(W)	(dBm)	(W)	(dBm)	(W)	(dBm)	(W)		
2412	6.5 M	12.47	0.018	12.33	0.017	21.46	0.140	21.33	0.136	< 30	
2437		12.19	0.017	12.05	0.016	21.14	0.130	21.01	0.126	< 30	
2462		12.42	0.017	12.28	0.017	21.29	0.135	21.16	0.131	< 30	
2437	13 M	12.15	0.016	12.01	0.016	21.10	0.129	20.97	0.125	< 30	
2437	19.5 M	12.07	0.016	11.93	0.016	21.02	0.126	20.89	0.123	< 30	
2437	26 M	11.99	0.016	11.85	0.015	20.94	0.124	20.81	0.121	< 30	
2437	39 M	11.93	0.016	11.79	0.015	20.88	0.122	20.75	0.119	< 30	
2437	52 M	11.87	0.015	11.73	0.015	20.82	0.121	20.69	0.117	< 30	
2437	58.5 M	11.81	0.015	11.67	0.015	20.76	0.119	20.63	0.116	< 30	
2437	65 M	11.77	0.015	11.63	0.015	20.72	0.118	20.59	0.115	< 30	

Model Number	PS2 Speaker										
Test Item	Maximum Conducted Output Power										
Test Mode	Mode 5: IEEE 802.11n 2.4GHz 40MHz Link Mode										
Date of Test	04/30/2013							Test Site		TE05	
Frequency (MHz)	Data Rate	Average Power				Peak Power				Limit (dBm)	
		ANTL		ANTR		ANTL		ANTR			
		(dBm)	(W)	(dBm)	(W)	(dBm)	(W)	(dBm)	(W)		
2422	13.5 M	11.88	0.015	11.72	0.015	21.10	0.129	20.92	0.124	< 30	
2437		11.68	0.015	11.52	0.014	20.93	0.124	20.75	0.119	< 30	
2452		11.20	0.013	11.04	0.013	20.52	0.113	20.34	0.108	< 30	
2437	27 M	11.64	0.015	11.48	0.014	20.91	0.123	20.73	0.118	< 30	
2437	40.5 M	11.56	0.014	11.40	0.014	20.87	0.122	20.69	0.117	< 30	
2437	54 M	11.50	0.014	11.34	0.014	20.84	0.121	20.66	0.116	< 30	
2437	81 M	11.42	0.014	11.26	0.013	20.80	0.120	20.62	0.115	< 30	
2437	108 M	11.34	0.014	11.18	0.013	20.76	0.119	20.58	0.114	< 30	
2437	121.5 M	11.28	0.013	11.12	0.013	20.73	0.118	20.55	0.114	< 30	
2437	135 M	11.24	0.013	11.08	0.013	20.71	0.118	20.53	0.113	< 30	

Model Number	PS2 Speaker									
Test Item	Maximum Conducted Output Power									
Test Mode	Mode 6: IEEE 802.11a U-NII Band IV Link Mode									
Date of Test	04/30/2013							Test Site	TE05	
Frequency (MHz)	Data Rate	Average Power				Peak Power				Limit (dBm)
		ANTL		ANTR		ANTL		ANTR		
		(dBm)	(W)	(dBm)	(W)	(dBm)	(W)	(dBm)	(W)	
5745	6 M	11.81	0.015	11.67	0.015	19.76	0.095	19.63	0.092	< 30
5765		12.00	0.016	11.86	0.015	19.82	0.096	19.69	0.093	< 30
5785		12.49	0.018	12.35	0.017	19.93	0.098	19.80	0.095	< 30
5805		11.76	0.015	11.62	0.015	19.73	0.094	19.60	0.091	< 30
5825		11.66	0.015	11.52	0.014	19.78	0.095	19.65	0.092	< 30
5745	54 M	11.70	0.015	11.54	0.014	19.63	0.092	19.49	0.089	< 30
5765		11.89	0.015	11.73	0.015	19.69	0.093	19.55	0.090	< 30
5785		12.38	0.017	12.22	0.017	19.80	0.095	19.66	0.092	< 30
5805		11.65	0.015	11.59	0.014	19.60	0.091	19.46	0.088	< 30
5825		11.55	0.014	11.51	0.014	19.65	0.092	19.54	0.090	< 30

Model Number	PS2 Speaker									
Test Item	Maximum Conducted Output Power									
Test Mode	Mode 7: IEEE 802.11n U-NII Band IV 20MHz Link Mode									
Date of Test	04/30/2013							Test Site	TE05	
Frequency (MHz)	Data Rate	Average Power				Peak Power				Limit (dBm)
		ANTL		ANTR		ANTL		ANTR		
		(dBm)	(W)	(dBm)	(W)	(dBm)	(W)	(dBm)	(W)	
5745	6.5 M	9.67	0.009	9.61	0.009	17.69	0.059	17.57	0.057	< 30
5765		9.88	0.010	9.82	0.010	17.88	0.061	17.76	0.060	< 30
5785		9.92	0.010	9.86	0.010	18.02	0.063	17.90	0.062	< 30
5805		10.11	0.010	10.05	0.010	18.22	0.066	18.10	0.065	< 30
5825		10.35	0.011	10.29	0.011	18.38	0.069	18.26	0.067	< 30
5745	65 M	9.57	0.009	9.55	0.009	17.56	0.057	17.48	0.056	< 30
5765		9.78	0.010	9.76	0.009	17.75	0.060	17.67	0.058	< 30
5785		9.82	0.010	9.80	0.010	17.89	0.062	17.81	0.060	< 30
5805		10.01	0.010	9.99	0.010	18.09	0.064	18.01	0.063	< 30
5825		10.25	0.011	10.23	0.011	18.25	0.067	18.17	0.066	< 30

Model Number	PS2 Speaker										
Test Item	Maximum Conducted Output Power										
Test Mode	Mode 8: IEEE 802.11n U-NII Band IV 40MHz Link Mode										
Date of Test	04/30/2013							Test Site	TE05		
Frequency (MHz)	Data Rate	Average Power				Peak Power				Limit (dBm)	
		ANTL		ANTR		ANTL		ANTR			
		(dBm)	(W)	(dBm)	(W)	(dBm)	(W)	(dBm)	(W)		
5755	6.5 M	10.14	0.010	10.01	0.010	18.14	0.065	17.99	0.063	< 30	
5795		10.35	0.011	10.22	0.011	18.74	0.075	18.59	0.072	< 30	
5755	65 M	10.02	0.010	9.93	0.010	18.00	0.063	17.88	0.061	< 30	
5795		10.23	0.011	10.14	0.010	18.60	0.072	18.48	0.070	< 30	

Model Number	PS2 Speaker					
Test Item	EIRP					
Test Mode	Mode 6: IEEE 802.11a U-NII Band IV Link Mode					
Date of Test	04/30/2013				Test Site	TE05
Frequency (MHz)	Data Rate	EIRP				Limit (dBm)
		ANTL		ANTR		
		(dBm)	(W)	(dBm)	(W)	
5745	6 M	23.45	0.221	24.99	0.316	< 36
5765		23.51	0.224	25.05	0.320	< 36
5785		23.62	0.230	25.16	0.328	< 36
5805		23.42	0.220	24.96	0.313	< 36
5825		23.47	0.222	25.01	0.317	< 36
5745	54 M	23.32	0.215	24.85	0.305	< 36
5765		23.38	0.218	24.91	0.310	< 36
5785		23.49	0.223	25.02	0.318	< 36
5805		23.29	0.213	24.82	0.303	< 36
5825		23.34	0.216	24.90	0.309	< 36

Model Number	PS2 Speaker					
Test Item	EIRP					
Test Mode	Mode 7: IEEE 802.11n U-NII Band IV 20MHz Link Mode					
Date of Test	04/30/2013				Test Site	TE05
Frequency (MHz)	Data Rate	EIRP				Limit (dBm)
		ANTL		ANTR		
		(dBm)	(W)	(dBm)	(W)	
5745	6 M	21.38	0.137	22.93	0.196	< 36
5765		21.57	0.144	23.12	0.205	< 36
5785		21.71	0.148	23.26	0.212	< 36
5805		21.91	0.155	23.46	0.222	< 36
5825		22.07	0.161	23.62	0.230	< 36
5745	54 M	21.25	0.133	22.84	0.192	< 36
5765		21.44	0.139	23.03	0.201	< 36
5785		21.58	0.144	23.17	0.207	< 36
5805		21.78	0.151	23.37	0.217	< 36
5825		21.94	0.156	23.53	0.225	< 36

EIRP = Conducted Peak Power + Antenna Gain

Model Number	PS2 Speaker					
Test Item	EIRP					
Test Mode	Mode 8: IEEE 802.11n U-NII Band IV 40MHz Link Mode					
Date of Test	04/30/2013				Test Site	TE05
Frequency (MHz)	Data Rate	EIRP				Limit (dBm)
		ANTL		ANTR		
		(dBm)	(W)	(dBm)	(W)	
5755	6.5 M	21.83	0.152	23.35	0.216	< 36
5795		22.43	0.175	23.95	0.248	< 36
5755	65 M	21.69	0.148	23.24	0.211	< 36
5795		22.29	0.169	23.84	0.242	< 36

EIRP = Conducted Peak Power + Antenna Gain

7 6dB RF Bandwidth & 99 % Occupied Bandwidth Measurement

7.1. Limit

6dB RF Bandwidth

Systems using digital modulation techniques may operate in the 2400–2483.5 MHz bands. The minimum 6 dB band-width shall be at least 500 kHz.

99 % Occupied Bandwidth

N/A

7.2. Test Setup

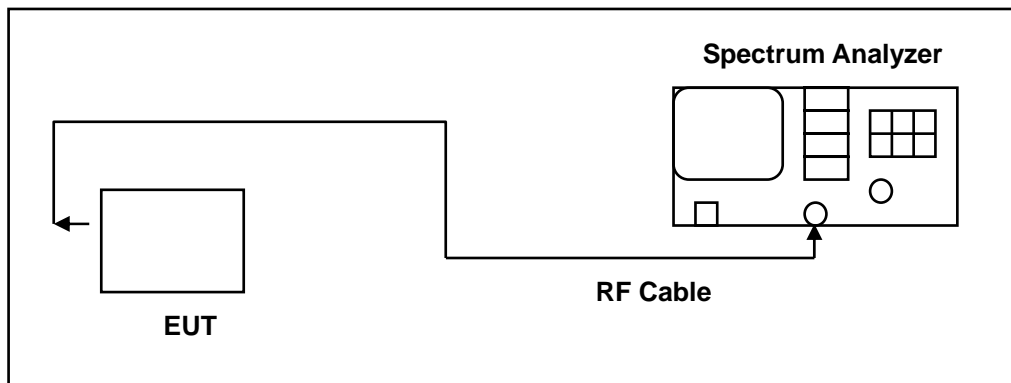

7.3. Test Instruments

Equipment	Manufacturer	Model Number	Serial Number	Cal. Date	Remark
Spectrum Analyzer	Agilent	E4445A	MY45300744	12/21/2011	(2)
Test Site	ATL	TE05	TE05	N.C.R.	-----

dRemark: (1) Calibration period 1 year. (2) Calibration period 2 years. (3) Calibration period 3 years.

Note: N.C.R. = No Calibration Request.

7.4. Test Procedure

6dB RF Bandwidth

The EUT was setup to ANSI C63.4, 2009; tested to DTS test procedure of Oct 2012 KDB558074 for compliance to FCC 47CFR 15.247 requirements.

The antenna port of the EUT was connected to the input of a spectrum analyzer. Analyzer RES BW was set to 100 kHz. For each RF output channel investigated, the spectrum analyzer center frequency was set to the channel carrier. A peak output reading was taken, a DISPLAY line was drawn 6 dB lower than peak level. The 6 dB bandwidth was determined from where the channel output spectrum intersected the display line.

The test was performed at 3 channels (Channel 1, 6, 11)

99 % Occupied Bandwidth

The transmitter shall be operated at its maximum carrier power measured under normal test conditions.

The span of the analyzer shall be set to capture all products of the modulation process, including the emission skirts.

The resolution bandwidth shall be set to as close to 1% of the selected span as is possible without being below 1%.

The video bandwidth shall be set to 3 times the resolution bandwidth. Video averaging is not permitted. Where practical, a sampling detector shall be used since a peak or, peak hold, may produce a wider bandwidth than actual.

The trace data points are recovered and are directly summed in linear terms. The recovered amplitude data points, beginning at the lowest frequency, are placed in a running sum until 0.5% of the total is reached and that frequency recorded. The process is repeated for the highest frequency data points. This frequency is recorded.

7.5. Test Result

Model Number	PS2 Speaker		
Test Item	6dB RF Bandwidth & 99 % Occupied Bandwidth		
Test Mode	Mode 2: IEEE 802.11b Link Mode		
Date of Test	05/02/2013	Test Site	TE05
Frequency (MHz)	6dB Bandwidth (kHz)	99% Occupied Bandwidth (kHz)	Limit (kHz)
2412	10051	136885	> 500
2437	10041	136555	> 500
2462	10036	136827	> 500

Model Number	PS2 Speaker		
Test Item	6dB RF Bandwidth & 99 % Occupied Bandwidth		
Test Mode	Mode 3: IEEE 802.11g Link Mode		
Date of Test	05/02/2013	Test Site	TE05
Frequency (MHz)	6dB Bandwidth (kHz)	99% Occupied Bandwidth (kHz)	Limit (kHz)
2412	16603	164375	> 500
2437	16448	164374	> 500
2462	16603	164421	> 500

Model Number	PS2 Speaker		
Test Item	6dB RF Bandwidth & 99 % Occupied Bandwidth		
Test Mode	Mode 4: IEEE 802.11n 2.4GHz 20MHz Link Mode		
Date of Test	05/02/2013	Test Site	TE05
Frequency (MHz)	6dB Bandwidth (kHz)	99% Occupied Bandwidth (kHz)	Limit (kHz)
2412	17837	176691	> 500
2437	17839	176776	> 500
2462	17858	176799	> 500

Model Number	PS2 Speaker		
Test Item	6dB RF Bandwidth & 99 % Occupied Bandwidth		
Test Mode	Mode 5: IEEE 802.11n 2.4GHz 40MHz Link Mode		
Date of Test	05/02/2013	Test Site	TE05
Frequency (MHz)	6dB Bandwidth (kHz)	99% Occupied Bandwidth (kHz)	Limit (kHz)
2422	36660	362666	> 500
2437	36652	362276	> 500
2452	36650	362283	> 500

Model Number	PS2 Speaker		
Test Item	6dB RF Bandwidth & 99 % Occupied Bandwidth		
Test Mode	Mode 6: IEEE 802.11a U-NII Band IV Link Mode		
Date of Test	05/02/2013	Test Site	TE05
Frequency (MHz)	6dB Bandwidth (kHz)	99% Occupied Bandwidth (kHz)	Limit (kHz)
5745	16611	164861	> 500
5785	16588	164936	> 500
5825	16362	164629	> 500

Model Number	PS2 Speaker		
Test Item	6dB RF Bandwidth & 99 % Occupied Bandwidth		
Test Mode	Mode 7: IEEE 802.11n U-NII Band IV 20MHz Link Mode		
Date of Test	05/02/2013	Test Site	TE05
Frequency (MHz)	6dB Bandwidth (kHz)	99% Occupied Bandwidth (kHz)	Limit (kHz)
5745	17826	176846	> 500
5785	17802	176781	> 500
5825	17853	176837	> 500

Model Number	PS2 Speaker		
Test Item	6dB RF Bandwidth & 99 % Occupied Bandwidth		
Test Mode	Mode 8: IEEE 802.11n U-NII Band IV 40MHz Link Mode		
Date of Test	05/02/2013	Test Site	TE05
Frequency (MHz)	6dB Bandwidth (kHz)	99% Occupied Bandwidth (kHz)	Limit (kHz)
5755	36646	362641	> 500
5795	36603	362140	> 500

7.6. Test Graphs

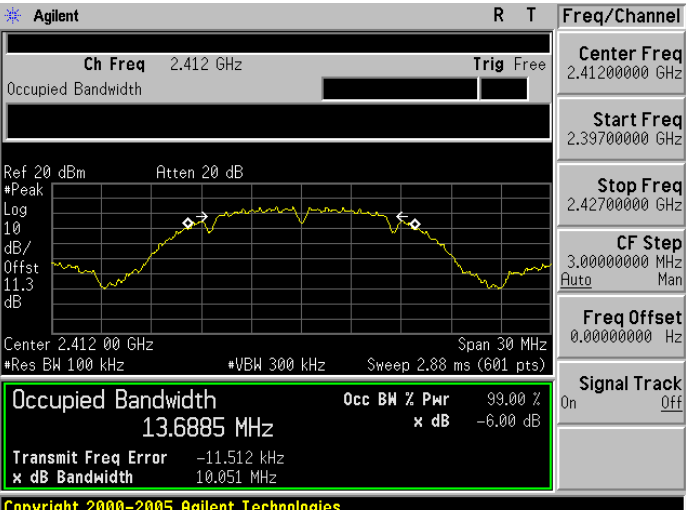
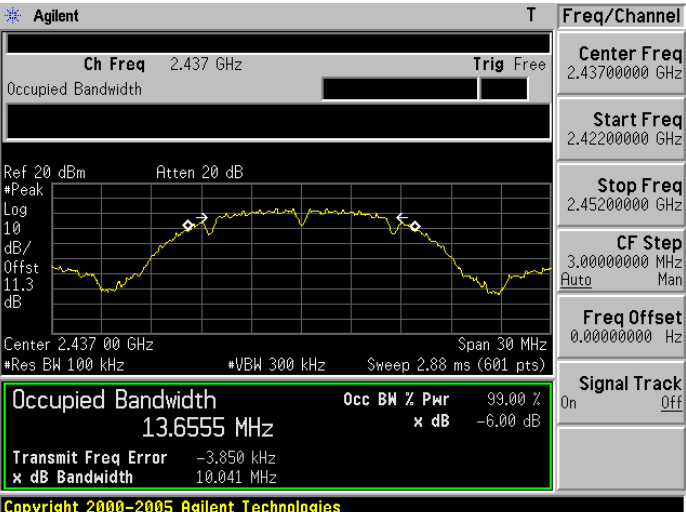
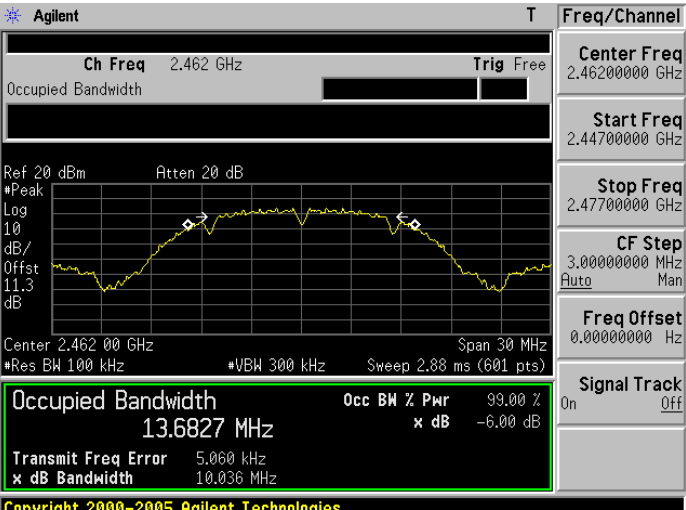
Mode 2: IEEE 802.11b Link Mode	
2412	
2437	
2462	

Mode 3: IEEE 802.11g Link Mode	
2412	<p>Agilent T</p> <p>Ch Freq 2.412 GHz Trig Free</p> <p>Center Freq 2.41200000 GHz</p> <p>Start Freq 2.39700000 GHz</p> <p>Stop Freq 2.42700000 GHz</p> <p>CF Step 3.00000000 MHz Auto Man</p> <p>Freq Offset 0.00000000 Hz</p> <p>Signal Track On Off</p> <p>Ref 20 dBm Atten 20 dB</p> <p>#Peak Log 10 dB/Offst 11.3 dB</p> <p>Center 2.412 00 GHz Span 30 MHz</p> <p>#Res BW 100 kHz #VBW 300 kHz Sweep 2.88 ms (601 pts)</p> <p>Occupied Bandwidth 16.4375 MHz</p> <p>Occ BW % Pwr 99.00 % x dB -6.00 dB</p> <p>Transmit Freq Error 1.184 kHz</p> <p>x dB Bandwidth 16.603 MHz</p> <p>Copyright 2000-2005 Agilent Technologies</p>
2437	<p>Agilent T</p> <p>Ch Freq 2.437 GHz Trig Free</p> <p>Center Freq 2.43700000 GHz</p> <p>Start Freq 2.42200000 GHz</p> <p>Stop Freq 2.45200000 GHz</p> <p>CF Step 3.00000000 MHz Auto Man</p> <p>Freq Offset 0.00000000 Hz</p> <p>Signal Track On Off</p> <p>Ref 20 dBm Atten 20 dB</p> <p>#Peak Log 10 dB/Offst 11.3 dB</p> <p>Center 2.437 00 GHz Span 30 MHz</p> <p>#Res BW 100 kHz #VBW 300 kHz Sweep 2.88 ms (601 pts)</p> <p>Occupied Bandwidth 16.4374 MHz</p> <p>Occ BW % Pwr 99.00 % x dB -6.00 dB</p> <p>Transmit Freq Error 1.663 kHz</p> <p>x dB Bandwidth 16.448 MHz</p> <p>Copyright 2000-2005 Agilent Technologies</p>
2462	<p>Agilent T</p> <p>Ch Freq 2.462 GHz Trig Free</p> <p>Center Freq 2.46200000 GHz</p> <p>Start Freq 2.44700000 GHz</p> <p>Stop Freq 2.47700000 GHz</p> <p>CF Step 3.00000000 MHz Auto Man</p> <p>Freq Offset 0.00000000 Hz</p> <p>Signal Track On Off</p> <p>Ref 20 dBm Atten 20 dB</p> <p>#Peak Log 10 dB/Offst 11.3 dB</p> <p>Center 2.462 00 GHz Span 30 MHz</p> <p>#Res BW 100 kHz #VBW 300 kHz Sweep 2.88 ms (601 pts)</p> <p>Occupied Bandwidth 16.4421 MHz</p> <p>Occ BW % Pwr 99.00 % x dB -6.00 dB</p> <p>Transmit Freq Error -2.326 kHz</p> <p>x dB Bandwidth 16.603 MHz</p> <p>Copyright 2000-2005 Agilent Technologies</p>

Mode 4: IEEE 802.11n 2.4GHz 20MHz Link Mode	
2412	<p>Agilent T Freq/Channel</p> <p>Ch Freq 2.412 GHz Trig Free</p> <p>Center Freq 2.41200000 GHz</p> <p>Start Freq 2.39700000 GHz</p> <p>Stop Freq 2.42700000 GHz</p> <p>CF Step 3.00000000 MHz Auto Man</p> <p>Freq Offset 0.00000000 Hz</p> <p>Signal Track On Off</p> <p>Ref 20 dBm Atten 20 dB</p> <p>#Peak Log 10 dB/Offst 11.3 dB</p> <p>Center 2.412 00 GHz Span 30 MHz</p> <p>#Res BW 100 kHz #VBW 300 kHz Sweep 2.88 ms (601 pts)</p> <p>Occupied Bandwidth 17.6691 MHz</p> <p>Occ BW % Pwr 99.00 % x dB -6.00 dB</p> <p>Transmit Freq Error 8.516 kHz</p> <p>x dB Bandwidth 17.837 MHz</p> <p>Copyright 2000-2005 Agilent Technologies</p>
2437	<p>Agilent T Freq/Channel</p> <p>Ch Freq 2.437 GHz Trig Free</p> <p>Center Freq 2.43700000 GHz</p> <p>Start Freq 2.42200000 GHz</p> <p>Stop Freq 2.45200000 GHz</p> <p>CF Step 3.00000000 MHz Auto Man</p> <p>Freq Offset 0.00000000 Hz</p> <p>Signal Track On Off</p> <p>Ref 20 dBm Atten 20 dB</p> <p>#Peak Log 10 dB/Offst 11.3 dB</p> <p>Center 2.437 00 GHz Span 30 MHz</p> <p>#Res BW 100 kHz #VBW 300 kHz Sweep 2.88 ms (601 pts)</p> <p>Occupied Bandwidth 17.6776 MHz</p> <p>Occ BW % Pwr 99.00 % x dB -6.00 dB</p> <p>Transmit Freq Error 12.037 kHz</p> <p>x dB Bandwidth 17.839 MHz</p> <p>Copyright 2000-2005 Agilent Technologies</p>
2462	<p>Agilent T Freq/Channel</p> <p>Ch Freq 2.462 GHz Trig Free</p> <p>Center Freq 2.46200000 GHz</p> <p>Start Freq 2.44700000 GHz</p> <p>Stop Freq 2.47700000 GHz</p> <p>CF Step 3.00000000 MHz Auto Man</p> <p>Freq Offset 0.00000000 Hz</p> <p>Signal Track On Off</p> <p>Ref 20 dBm Atten 20 dB</p> <p>#Peak Log 10 dB/Offst 11.3 dB</p> <p>Center 2.462 00 GHz Span 30 MHz</p> <p>#Res BW 100 kHz #VBW 300 kHz Sweep 2.88 ms (601 pts)</p> <p>Occupied Bandwidth 17.6799 MHz</p> <p>Occ BW % Pwr 99.00 % x dB -6.00 dB</p> <p>Transmit Freq Error 12.986 kHz</p> <p>x dB Bandwidth 17.858 MHz</p> <p>Copyright 2000-2005 Agilent Technologies</p>

Mode 5: IEEE 802.11n 2.4GHz 40MHz Link Mode	
2422	<p>Agilent T</p> <p>Ch Freq 2.422 GHz Trig Free</p> <p>Center Freq 2.42200000 GHz</p> <p>Start Freq 2.39200000 GHz</p> <p>Stop Freq 2.45200000 GHz</p> <p>CF Step 6.00000000 MHz</p> <p>Freq Offset 0.00000000 Hz</p> <p>Signal Track On</p> <p>Ref 20 dBm Atten 20 dB</p> <p>#Peak 10</p> <p>Log dB/Offst 11.3 dB</p> <p>Center 2.422 00 GHz Span 60 MHz</p> <p>#Res BW 100 kHz #VBW 300 kHz Sweep 5.76 ms (601 pts)</p> <p>Occupied Bandwidth 36.2666 MHz</p> <p>Occ BW % Pwr 99.00 %</p> <p>x dB -6.00 dB</p> <p>Transmit Freq Error 10.621 kHz</p> <p>x dB Bandwidth 36.660 MHz</p> <p>Copyright 2000-2005 Agilent Technologies</p>
2437	<p>Agilent T</p> <p>Ch Freq 2.437 GHz Trig Free</p> <p>Center Freq 2.43700000 GHz</p> <p>Start Freq 2.40700000 GHz</p> <p>Stop Freq 2.46700000 GHz</p> <p>CF Step 6.00000000 MHz</p> <p>Freq Offset 0.00000000 Hz</p> <p>Signal Track On</p> <p>Ref 20 dBm Atten 20 dB</p> <p>#Peak 10</p> <p>Log dB/Offst 11.3 dB</p> <p>Center 2.437 00 GHz Span 60 MHz</p> <p>#Res BW 100 kHz #VBW 300 kHz Sweep 5.76 ms (601 pts)</p> <p>Occupied Bandwidth 36.2276 MHz</p> <p>Occ BW % Pwr 99.00 %</p> <p>x dB -6.00 dB</p> <p>Transmit Freq Error 12.394 kHz</p> <p>x dB Bandwidth 36.652 MHz</p> <p>Copyright 2000-2005 Agilent Technologies</p>
2452	<p>Agilent T</p> <p>Ch Freq 2.452 GHz Trig Free</p> <p>Center Freq 2.45200000 GHz</p> <p>Start Freq 2.42200000 GHz</p> <p>Stop Freq 2.48200000 GHz</p> <p>CF Step 6.00000000 MHz</p> <p>Freq Offset 0.00000000 Hz</p> <p>Signal Track On</p> <p>Ref 20 dBm Atten 20 dB</p> <p>#Peak 10</p> <p>Log dB/Offst 11.3 dB</p> <p>Start 2.422 00 GHz Stop 2.482 00 GHz</p> <p>#Res BW 100 kHz #VBW 300 kHz Sweep 5.76 ms (601 pts)</p> <p>Occupied Bandwidth 36.2283 MHz</p> <p>Occ BW % Pwr 99.00 %</p> <p>x dB -6.00 dB</p> <p>Transmit Freq Error 4.611 kHz</p> <p>x dB Bandwidth 36.650 MHz</p> <p>Copyright 2000-2005 Agilent Technologies</p>

Mode 6: IEEE 802.11a U-NII Band IV Link Mode	
5745	<p>Agilent R T Freq/Channel</p> <p>Ch Freq 5.745 GHz Trig Free</p> <p>Center Freq 5.74500000 GHz</p> <p>Start Freq 5.73000000 GHz</p> <p>Stop Freq 5.76000000 GHz</p> <p>CF Step 3.00000000 MHz Auto Man</p> <p>Freq Offset 0.00000000 Hz</p> <p>Signal Track On Off</p> <p>Ref 20 dBm Atten 20 dB</p> <p>#Peak Log 10 dB/Offst 11.8 dB</p> <p>Center 5.745 00 GHz Span 30 MHz</p> <p>#Res BW 100 kHz #VBW 300 kHz Sweep 2.88 ms (601 pts)</p> <p>Occupied Bandwidth 16.4861 MHz</p> <p>Occ BW % Pwr 99.00 % x dB -6.00 dB</p> <p>Transmit Freq Error -1.344 kHz</p> <p>x dB Bandwidth 16.611 MHz</p> <p>Copyright 2000-2005 Agilent Technologies</p>
5785	<p>Agilent T Freq/Channel</p> <p>Ch Freq 5.785 GHz Trig Free</p> <p>Center Freq 5.78500000 GHz</p> <p>Start Freq 5.77000000 GHz</p> <p>Stop Freq 5.80000000 GHz</p> <p>CF Step 3.00000000 MHz Auto Man</p> <p>Freq Offset 0.00000000 Hz</p> <p>Signal Track On Off</p> <p>Ref 20 dBm Atten 20 dB</p> <p>#Peak Log 10 dB/Offst 11.8 dB</p> <p>Center 5.785 00 GHz Span 30 MHz</p> <p>#Res BW 100 kHz #VBW 300 kHz Sweep 2.88 ms (601 pts)</p> <p>Occupied Bandwidth 16.4936 MHz</p> <p>Occ BW % Pwr 99.00 % x dB -6.00 dB</p> <p>Transmit Freq Error 6.181 kHz</p> <p>x dB Bandwidth 16.588 MHz</p> <p>Copyright 2000-2005 Agilent Technologies</p>
5825	<p>Agilent T Freq/Channel</p> <p>Ch Freq 5.825 GHz Trig Free</p> <p>Center Freq 5.82500000 GHz</p> <p>Start Freq 5.81000000 GHz</p> <p>Stop Freq 5.84000000 GHz</p> <p>CF Step 3.00000000 MHz Auto Man</p> <p>Freq Offset 0.00000000 Hz</p> <p>Signal Track On Off</p> <p>Ref 20 dBm Atten 20 dB</p> <p>#Peak Log 10 dB/Offst 11.8 dB</p> <p>Center 5.825 00 GHz Span 30 MHz</p> <p>#Res BW 100 kHz #VBW 300 kHz Sweep 2.88 ms (601 pts)</p> <p>Occupied Bandwidth 16.4629 MHz</p> <p>Occ BW % Pwr 99.00 % x dB -6.00 dB</p> <p>Transmit Freq Error 15.903 kHz</p> <p>x dB Bandwidth 16.362 MHz</p> <p>Copyright 2000-2005 Agilent Technologies</p>

Mode 7: IEEE 802.11n U-NII Band IV 20MHz Link Mode	
5745	
5785	
5825	

Mode 8: IEEE 802.11n U-NII Band IV 40MHz Link Mode

<p>5755</p>	<p>Agilent T Freq/Channel</p> <p>Ch Freq 5.755 GHz Trig Free</p> <p>Center Freq 5.7550000 GHz</p> <p>Start Freq 5.7250000 GHz</p> <p>Stop Freq 5.7850000 GHz</p> <p>CF Step 6.0000000 MHz Auto Man</p> <p>Freq Offset 0.0000000 Hz</p> <p>Signal Track On Off</p> <p>Ref 20 dBm Atten 20 dB</p> <p>#Peak Log 10 dB/ Offst 11.8 dB</p> <p>Center 5.755 00 GHz Span 60 MHz</p> <p>#Res BW 100 kHz #VBW 300 kHz Sweep 5.76 ms (601 pts)</p> <p>Occupied Bandwidth 36.2641 MHz</p> <p>Occ BW % Pwr 99.00 %</p> <p>x dB -6.00 dB</p> <p>Transmit Freq Error -2.312 kHz</p> <p>x dB Bandwidth 36.646 MHz</p> <p>Copyright 2000-2005 Agilent Technologies</p>
<p>5795</p>	<p>Agilent T Freq/Channel</p> <p>Ch Freq 5.795 GHz Trig Free</p> <p>Center Freq 5.7950000 GHz</p> <p>Start Freq 5.7650000 GHz</p> <p>Stop Freq 5.8250000 GHz</p> <p>CF Step 6.0000000 MHz Auto Man</p> <p>Freq Offset 0.0000000 Hz</p> <p>Signal Track On Off</p> <p>Ref 20 dBm Atten 20 dB</p> <p>#Peak Log 10 dB/ Offst 11.8 dB</p> <p>Center 5.795 00 GHz Span 60 MHz</p> <p>#Res BW 100 kHz #VBW 300 kHz Sweep 5.76 ms (601 pts)</p> <p>Occupied Bandwidth 36.2140 MHz</p> <p>Occ BW % Pwr 99.00 %</p> <p>x dB -6.00 dB</p> <p>Transmit Freq Error 18.677 kHz</p> <p>x dB Bandwidth 36.603 MHz</p> <p>Copyright 2000-2005 Agilent Technologies</p>

8 Maximum Power Density Measurement

8.1. Limit

For digitally modulated systems, the power spectral density conducted from the intentional radiator to the antenna shall not be greater than 8 dBm in any 3 kHz band during any time interval of continuous transmission.

8.2. Test Setup

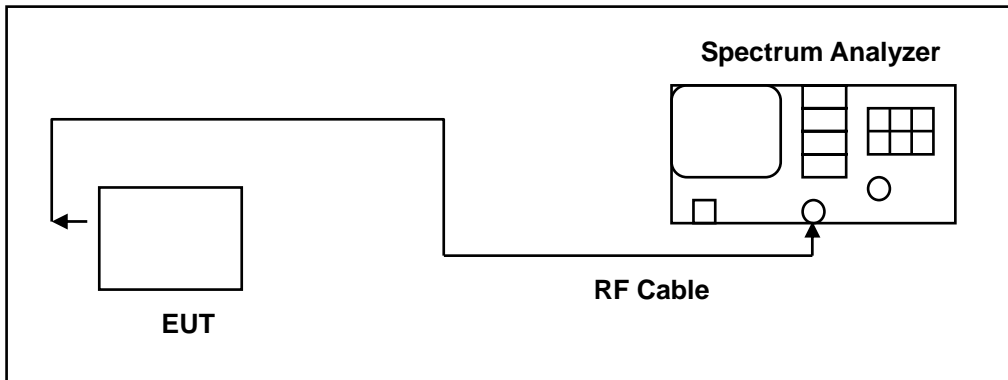

8.3. Test Instruments

Equipment	Manufacturer	Model Number	Serial Number	Cal. Date	Remark
Spectrum Analyzer	Agilent	E4445A	MY45300744	12/21/2011	(2)
Test Site	ATL	TE05	TE05	N.C.R.	-----

Remark: (1) Calibration period 1 year. (2) Calibration period 2 years. (3) Calibration period 3 years.

Note: N.C.R. = No Calibration Request.

8.4. Test Procedure

The EUT was setup to ANSI C63.4, 2009; tested to DTS test procedure of KDB558074D01 for compliance to FCC 47CFR 15.247 requirements.

- 1) The EUT was directly connect to the spectrum analyzer and antenna output port as show in the block diagram below,
- 2) Spectrum Setting: RBW=100KHz, VBW=300KHz, Sweep time=Auto. Span to 5-30% greater than EBW
- 3) Scale the observed power level to an equivalent value in 3kHz by adjusting(reducing) the measured power by a bandwidth correction factor(BWCF) where $BWCF=10\log(3\text{kHz}/100\text{kHz}=-15.3\text{dB})$.
- 4) Use peak detector+BWCF.
- 5) The resulting peak PSD level must be $\leq 8\text{dBm}$.

8.5. Test Result

Model Number	PS2 Speaker			
Test Item	Maximum Power Density			
Test Mode	Mode 2: IEEE 802.11b Link Mode			
Date of Test	05/02/2013		Test Site	TE05
Frequency (MHz)	Reading (dBm/100KHz)	BWCF (dB)	Results (dBm/3KHz)	Limit (dBm)
2412	4.08	-15.30	-11.22	< 8
2437	3.38	-15.30	-11.92	< 8
2462	3.68	-15.30	-11.62	< 8

Model Number	PS2 Speaker			
Test Item	Maximum Power Density			
Test Mode	Mode 3: IEEE 802.11g Link Mode			
Date of Test	05/02/2013		Test Site	TE05
Frequency (MHz)	Reading (dBm/100KHz)	BWCF (dB)	Results (dBm/3KHz)	Limit (dBm)
2412	-0.71	-15.30	-16.01	< 8
2437	-0.53	-15.30	-15.83	< 8
2462	-0.28	-15.30	-15.58	< 8

Model Number	PS2 Speaker			
Test Item	Maximum Power Density			
Test Mode	Mode 4: IEEE 802.11n 2.4GHz 20MHz Link Mode			
Date of Test	05/02/2013		Test Site	TE05
Frequency (MHz)	Reading (dBm/100KHz)	BWCF (dB)	Results (dBm/3KHz)	Limit (dBm)
2412	-1.28	-15.30	-16.58	< 8
2437	-1.30	-15.30	-16.60	< 8
2462	-1.11	-15.30	-16.41	< 8

Model Number	PS2 Speaker			
Test Item	Maximum Power Density			
Test Mode	Mode 5: IEEE 802.11n 2.4GHz 40MHz Link Mode			
Date of Test	05/02/2013		Test Site	TE05
Frequency (MHz)	Reading (dBm/100KHz)	BWCF (dB)	Results (dBm/3KHz)	Limit (dBm)
2422	-5.24	-15.30	-20.54	< 8
2437	-5.45	-15.30	-20.75	< 8
2452	-6.11	-15.30	-21.41	< 8

Model Number	PS2 Speaker			
Test Item	Maximum Power Density			
Test Mode	Mode 6: IEEE 802.11a U-NII Band IV Link Mode			
Date of Test	05/02/2013		Test Site	TE05
Frequency (MHz)	Reading (dBm/100KHz)	BWCF (dB)	Results (dBm/3KHz)	Limit (dBm)
5745	-1.28	-15.30	-16.58	< 8
5785	-1.17	-15.30	-16.47	< 8
5825	-2.70	-15.30	-18.00	< 8

Model Number	PS2 Speaker			
Test Item	Maximum Power Density			
Test Mode	Mode 7: IEEE 802.11n U-NII Band IV 20MHz Link Mode			
Date of Test	05/02/2013		Test Site	TE05
Frequency (MHz)	Reading (dBm/100KHz)	BWCF (dB)	Results (dBm/3KHz)	Limit (dBm)
5745	-3.45	-15.30	-18.75	< 8
5785	-3.54	-15.30	-18.84	< 8
5825	-4.27	-15.30	-19.57	< 8

Model Number	PS2 Speaker			
Test Item	Maximum Power Density			
Test Mode	Mode 8: IEEE 802.11n U-NII Band IV 40MHz Link Mode			
Date of Test	05/02/2013		Test Site	TE05
Frequency (MHz)	Reading (dBm/100KHz)	BWCF (dB)	Results (dBm/3KHz)	Limit (dBm)
5755	-6.78	-15.30	-22.08	< 8
5795	-6.68	-15.30	-21.98	< 8

8.6. Test Graphs

Mode 2: IEEE 802.11b Link Mode	
2412	<p>Agilent T Freq/Channel</p> <p>Ref 20 dBm Atten 20 dB Mkr1 2.411 50 GHz #Peak 4.08 dBm Log 10 dB/ Offst 11.3 dB LgAv M1 S2 S3 FC AL E(f): FTun Swp</p> <p>Center 2.412 00 GHz Span 15 MHz #Res BW 100 kHz #VBW 300 kHz Sweep 1.44 ms (601 pts)</p> <p>Copyright 2000-2005 Agilent Technologies</p> <p>Center Freq 2.41200000 GHz Start Freq 2.40450000 GHz Stop Freq 2.41950000 GHz CF Step 1.50000000 MHz Auto Man Freq Offset 0.00000000 Hz Signal Track On Off</p>
2437	<p>Agilent T Freq/Channel</p> <p>Ref 20 dBm Atten 20 dB Mkr1 2.435 50 GHz #Peak 3.38 dBm Log 10 dB/ Offst 11.3 dB LgAv M1 S2 S3 FC AL E(f): FTun Swp</p> <p>Center 2.437 00 GHz Span 15 MHz #Res BW 100 kHz #VBW 300 kHz Sweep 1.44 ms (601 pts)</p> <p>Copyright 2000-2005 Agilent Technologies</p> <p>Center Freq 2.43700000 GHz Start Freq 2.42950000 GHz Stop Freq 2.44450000 GHz CF Step 1.50000000 MHz Auto Man Freq Offset 0.00000000 Hz Signal Track On Off</p>
2462	<p>Agilent T Freq/Channel</p> <p>Ref 20 dBm Atten 20 dB Mkr1 2.461 50 GHz #Peak 3.68 dBm Log 10 dB/ Offst 11.3 dB LgAv M1 S2 S3 FC AL E(f): FTun Swp</p> <p>Center 2.462 00 GHz Span 15 MHz #Res BW 100 kHz #VBW 300 kHz Sweep 1.44 ms (601 pts)</p> <p>Copyright 2000-2005 Agilent Technologies</p> <p>Center Freq 2.46200000 GHz Start Freq 2.45450000 GHz Stop Freq 2.46950000 GHz CF Step 1.50000000 MHz Auto Man Freq Offset 0.00000000 Hz Signal Track On Off</p>

Mode 3: IEEE 802.11g Link Mode

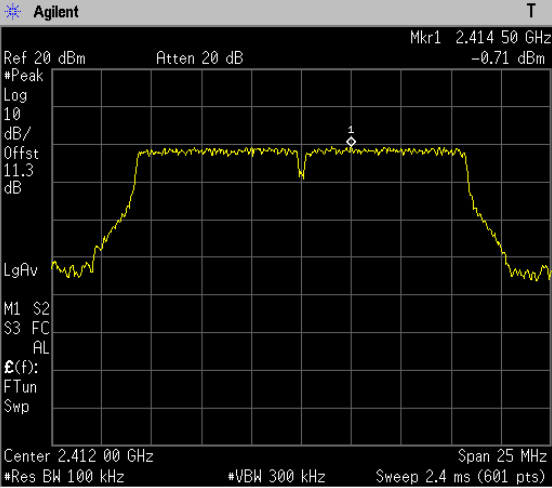
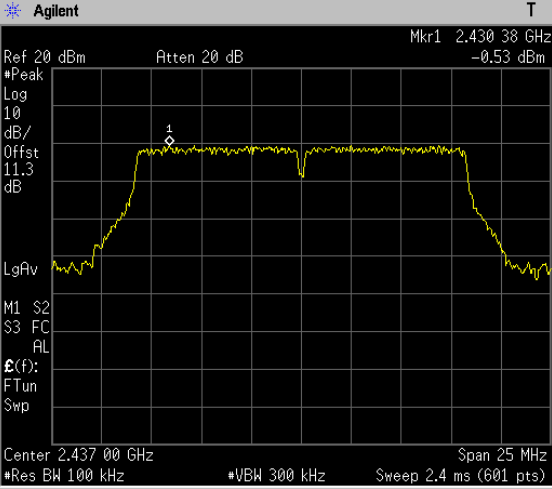
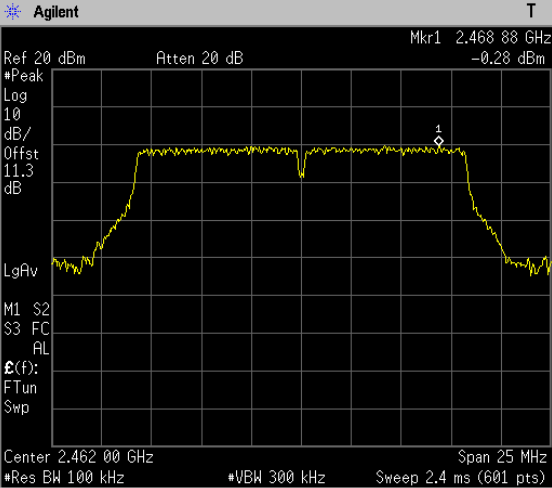
2412	 <p>Agilent T Freq/Channel</p> <p>Ref 20 dBm Atten 20 dB Mkr1 2.414 50 GHz #Peak -0.71 dBm Log 10 dB/ Offst 11.3 dB LgAv</p> <p>M1 S2 S3 FC AL E(f): FTun Swp</p> <p>Center 2.412 00 GHz Span 25 MHz #Res BW 100 kHz #VBW 300 kHz Sweep 2.4 ms (601 pts)</p> <p>Center Freq 2.41200000 GHz Start Freq 2.39950000 GHz Stop Freq 2.42450000 GHz CF Step 2.50000000 MHz Auto Man Freq Offset 0.00000000 Hz Signal Track On Off</p> <p>Copyright 2000-2005 Agilent Technologies</p>
2437	 <p>Agilent T Freq/Channel</p> <p>Ref 20 dBm Atten 20 dB Mkr1 2.430 38 GHz #Peak -0.53 dBm Log 10 dB/ Offst 11.3 dB LgAv</p> <p>M1 S2 S3 FC AL E(f): FTun Swp</p> <p>Center 2.437 00 GHz Span 25 MHz #Res BW 100 kHz #VBW 300 kHz Sweep 2.4 ms (601 pts)</p> <p>Center Freq 2.43700000 GHz Start Freq 2.42450000 GHz Stop Freq 2.44950000 GHz CF Step 2.50000000 MHz Auto Man Freq Offset 0.00000000 Hz Signal Track On Off</p> <p>Copyright 2000-2005 Agilent Technologies</p>
2462	 <p>Agilent T Freq/Channel</p> <p>Ref 20 dBm Atten 20 dB Mkr1 2.468 88 GHz #Peak -0.28 dBm Log 10 dB/ Offst 11.3 dB LgAv</p> <p>M1 S2 S3 FC AL E(f): FTun Swp</p> <p>Center 2.462 00 GHz Span 25 MHz #Res BW 100 kHz #VBW 300 kHz Sweep 2.4 ms (601 pts)</p> <p>Center Freq 2.46200000 GHz Start Freq 2.44950000 GHz Stop Freq 2.47450000 GHz CF Step 2.50000000 MHz Auto Man Freq Offset 0.00000000 Hz Signal Track On Off</p> <p>Copyright 2000-2005 Agilent Technologies</p>

Mode 4: IEEE 802.11n 2.4GHz 20MHz Link Mode

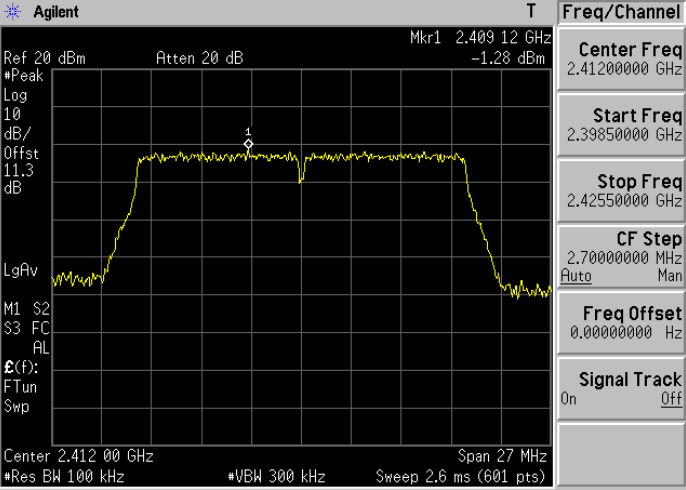
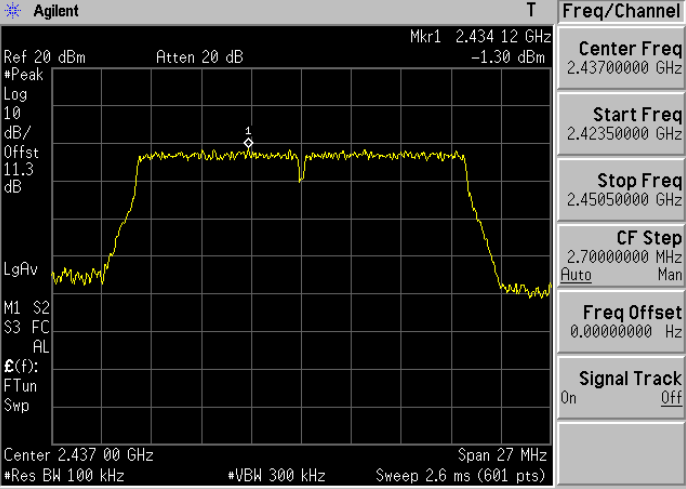
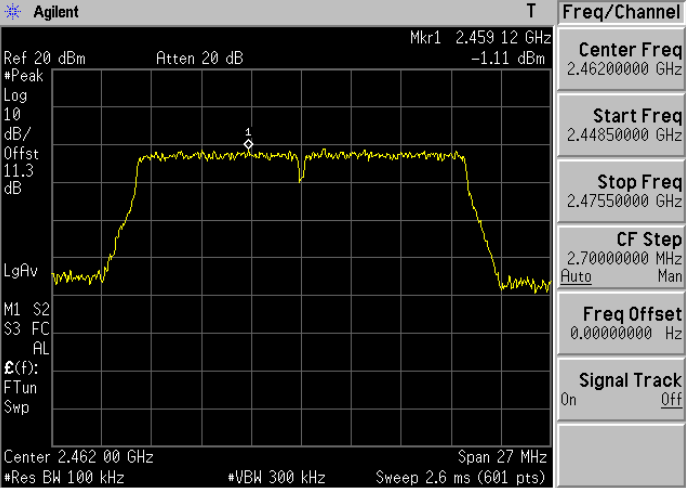
2412	 <p>Agilent T Freq/Channel</p> <p>Ref 20 dBm Atten 20 dB Mkr1 2.409 12 GHz #Peak -1.28 dBm Log 10 dB/Offst 11.3 dB LgAv M1 S2 S3 FC AL E(f): FTun Swp</p> <p>Center 2.412 00 GHz Span 27 MHz #Res BW 100 kHz #VBW 300 kHz Sweep 2.6 ms (601 pts)</p> <p>Copyright 2000-2005 Agilent Technologies</p> <table border="1"> <tr><td>Center Freq</td><td>2.41200000 GHz</td></tr> <tr><td>Start Freq</td><td>2.39850000 GHz</td></tr> <tr><td>Stop Freq</td><td>2.42550000 GHz</td></tr> <tr><td>CF Step</td><td>2.70000000 MHz Auto Man</td></tr> <tr><td>Freq Offset</td><td>0.00000000 Hz</td></tr> <tr><td>Signal Track</td><td>On Off</td></tr> </table>	Center Freq	2.41200000 GHz	Start Freq	2.39850000 GHz	Stop Freq	2.42550000 GHz	CF Step	2.70000000 MHz Auto Man	Freq Offset	0.00000000 Hz	Signal Track	On Off
Center Freq	2.41200000 GHz												
Start Freq	2.39850000 GHz												
Stop Freq	2.42550000 GHz												
CF Step	2.70000000 MHz Auto Man												
Freq Offset	0.00000000 Hz												
Signal Track	On Off												
2437	 <p>Agilent T Freq/Channel</p> <p>Ref 20 dBm Atten 20 dB Mkr1 2.434 12 GHz #Peak -1.30 dBm Log 10 dB/Offst 11.3 dB LgAv M1 S2 S3 FC AL E(f): FTun Swp</p> <p>Center 2.437 00 GHz Span 27 MHz #Res BW 100 kHz #VBW 300 kHz Sweep 2.6 ms (601 pts)</p> <p>Copyright 2000-2005 Agilent Technologies</p> <table border="1"> <tr><td>Center Freq</td><td>2.43700000 GHz</td></tr> <tr><td>Start Freq</td><td>2.42350000 GHz</td></tr> <tr><td>Stop Freq</td><td>2.45050000 GHz</td></tr> <tr><td>CF Step</td><td>2.70000000 MHz Auto Man</td></tr> <tr><td>Freq Offset</td><td>0.00000000 Hz</td></tr> <tr><td>Signal Track</td><td>On Off</td></tr> </table>	Center Freq	2.43700000 GHz	Start Freq	2.42350000 GHz	Stop Freq	2.45050000 GHz	CF Step	2.70000000 MHz Auto Man	Freq Offset	0.00000000 Hz	Signal Track	On Off
Center Freq	2.43700000 GHz												
Start Freq	2.42350000 GHz												
Stop Freq	2.45050000 GHz												
CF Step	2.70000000 MHz Auto Man												
Freq Offset	0.00000000 Hz												
Signal Track	On Off												
2462	 <p>Agilent T Freq/Channel</p> <p>Ref 20 dBm Atten 20 dB Mkr1 2.459 12 GHz #Peak -1.11 dBm Log 10 dB/Offst 11.3 dB LgAv M1 S2 S3 FC AL E(f): FTun Swp</p> <p>Center 2.462 00 GHz Span 27 MHz #Res BW 100 kHz #VBW 300 kHz Sweep 2.6 ms (601 pts)</p> <p>Copyright 2000-2005 Agilent Technologies</p> <table border="1"> <tr><td>Center Freq</td><td>2.46200000 GHz</td></tr> <tr><td>Start Freq</td><td>2.44850000 GHz</td></tr> <tr><td>Stop Freq</td><td>2.47550000 GHz</td></tr> <tr><td>CF Step</td><td>2.70000000 MHz Auto Man</td></tr> <tr><td>Freq Offset</td><td>0.00000000 Hz</td></tr> <tr><td>Signal Track</td><td>On Off</td></tr> </table>	Center Freq	2.46200000 GHz	Start Freq	2.44850000 GHz	Stop Freq	2.47550000 GHz	CF Step	2.70000000 MHz Auto Man	Freq Offset	0.00000000 Hz	Signal Track	On Off
Center Freq	2.46200000 GHz												
Start Freq	2.44850000 GHz												
Stop Freq	2.47550000 GHz												
CF Step	2.70000000 MHz Auto Man												
Freq Offset	0.00000000 Hz												
Signal Track	On Off												

Mode 5: IEEE 802.11n 2.4GHz 40MHz Link Mode

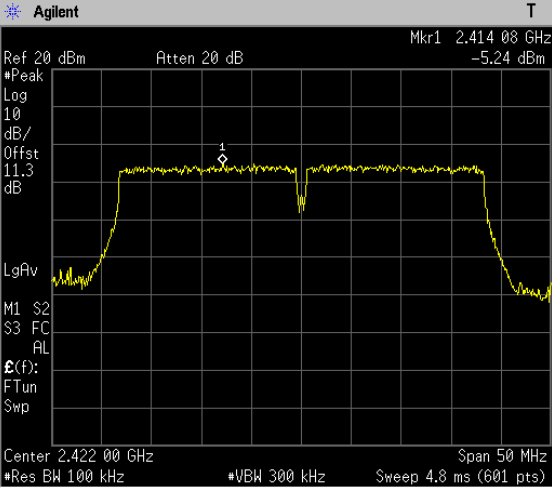
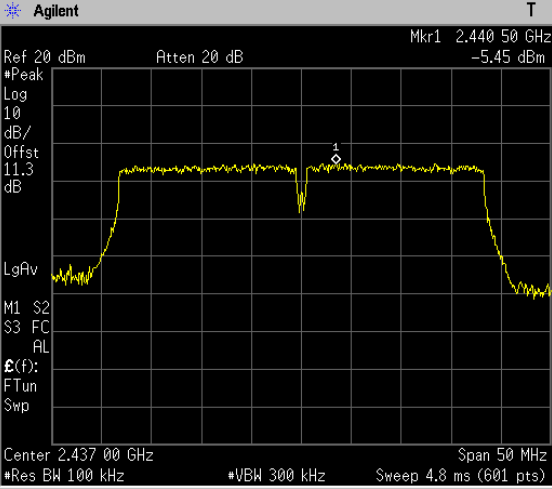
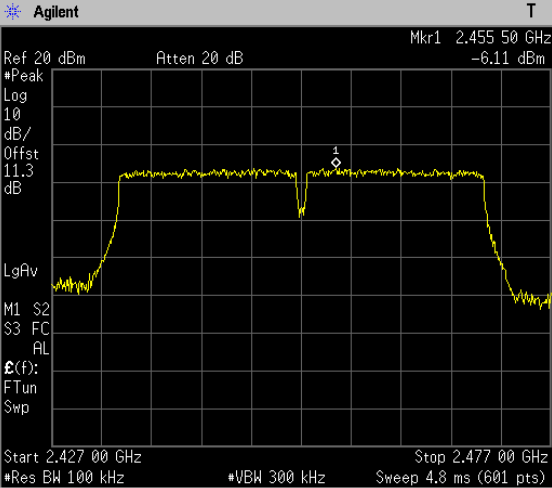
<p>2422</p>	 <p>Agilent T Freq/Channel</p> <p>Ref 20 dBm Atten 20 dB Mkr1 2.414 08 GHz -5.24 dBm</p> <p>#Peak 2.42200000 GHz</p> <p>Log 10 dB/dB/ Offst 11.3 dB</p> <p>LgAv</p> <p>M1 S2 S3 FC AL</p> <p>Ⓔ(f): FTun Swp</p> <p>Center 2.422 00 GHz Span 50 MHz #Res BW 100 kHz #VBW 300 kHz Sweep 4.8 ms (601 pts)</p> <p>Center Freq 2.42200000 GHz</p> <p>Start Freq 2.39700000 GHz</p> <p>Stop Freq 2.44700000 GHz</p> <p>CF Step 5.00000000 MHz Auto Man</p> <p>Freq Offset 0.00000000 Hz</p> <p>Signal Track On Off</p> <p>Copyright 2000-2005 Agilent Technologies</p>
<p>2437</p>	 <p>Agilent T Freq/Channel</p> <p>Ref 20 dBm Atten 20 dB Mkr1 2.440 50 GHz -5.45 dBm</p> <p>#Peak 2.43700000 GHz</p> <p>Log 10 dB/dB/ Offst 11.3 dB</p> <p>LgAv</p> <p>M1 S2 S3 FC AL</p> <p>Ⓔ(f): FTun Swp</p> <p>Center 2.437 00 GHz Span 50 MHz #Res BW 100 kHz #VBW 300 kHz Sweep 4.8 ms (601 pts)</p> <p>Center Freq 2.43700000 GHz</p> <p>Start Freq 2.41200000 GHz</p> <p>Stop Freq 2.46200000 GHz</p> <p>CF Step 5.00000000 MHz Auto Man</p> <p>Freq Offset 0.00000000 Hz</p> <p>Signal Track On Off</p> <p>Copyright 2000-2005 Agilent Technologies</p>
<p>2452</p>	 <p>Agilent T Freq/Channel</p> <p>Ref 20 dBm Atten 20 dB Mkr1 2.455 50 GHz -6.11 dBm</p> <p>#Peak 2.45200000 GHz</p> <p>Log 10 dB/dB/ Offst 11.3 dB</p> <p>LgAv</p> <p>M1 S2 S3 FC AL</p> <p>Ⓔ(f): FTun Swp</p> <p>Start 2.427 00 GHz Stop 2.477 00 GHz</p> <p>#Res BW 100 kHz #VBW 300 kHz Sweep 4.8 ms (601 pts)</p> <p>Center Freq 2.45200000 GHz</p> <p>Start Freq 2.42700000 GHz</p> <p>Stop Freq 2.47700000 GHz</p> <p>CF Step 5.00000000 MHz Auto Man</p> <p>Freq Offset 0.00000000 Hz</p> <p>Signal Track On Off</p> <p>Copyright 2000-2005 Agilent Technologies</p>

Mode 6: IEEE 802.11a U-NII Band IV Link Mode

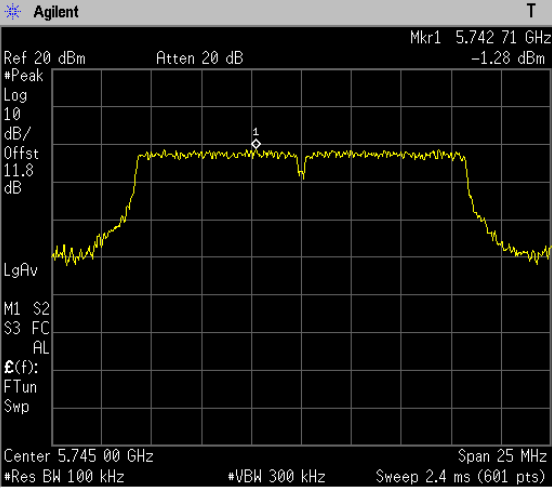
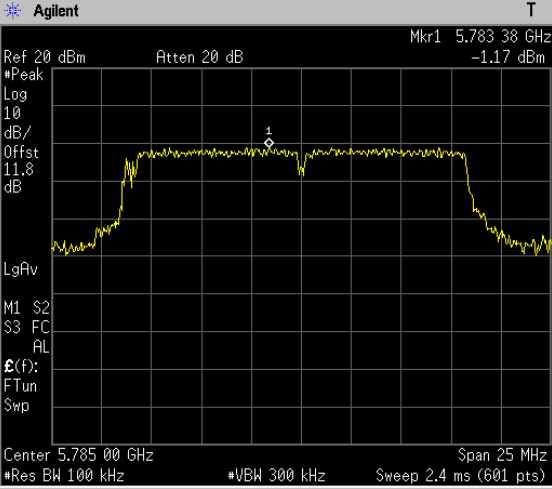
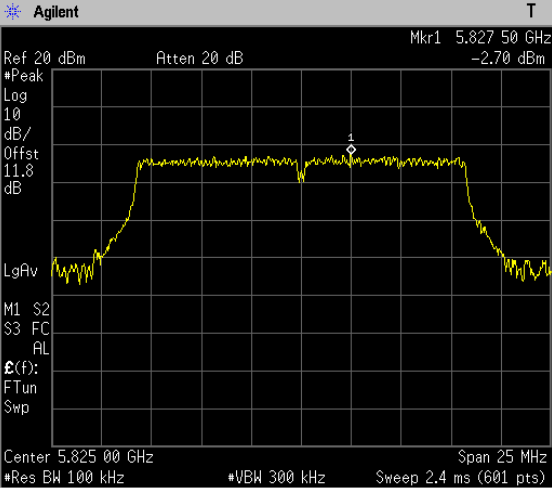
5745	 <p>Agilent T Freq/Channel</p> <p>Ref 20 dBm Atten 20 dB Mkr1 5.742 71 GHz #Peak -1.28 dBm Log 10 dB/ Offst 11.8 dB LgAv</p> <p>M1 S2 S3 FC AL</p> <p>Ⓔ(f): FTun Swp</p> <p>Center 5.745 00 GHz Span 25 MHz #Res BW 100 kHz #VBW 300 kHz Sweep 2.4 ms (601 pts)</p> <p>Copyright 2000-2005 Agilent Technologies</p> <p>Center Freq 5.74500000 GHz Start Freq 5.73250000 GHz Stop Freq 5.75750000 GHz CF Step 2.50000000 MHz Auto Man Freq Offset 0.00000000 Hz Signal Track On Off</p>
5785	 <p>Agilent T Freq/Channel</p> <p>Ref 20 dBm Atten 20 dB Mkr1 5.783 38 GHz #Peak -1.17 dBm Log 10 dB/ Offst 11.8 dB LgAv</p> <p>M1 S2 S3 FC AL</p> <p>Ⓔ(f): FTun Swp</p> <p>Center 5.785 00 GHz Span 25 MHz #Res BW 100 kHz #VBW 300 kHz Sweep 2.4 ms (601 pts)</p> <p>Copyright 2000-2005 Agilent Technologies</p> <p>Center Freq 5.78500000 GHz Start Freq 5.77250000 GHz Stop Freq 5.79750000 GHz CF Step 2.50000000 MHz Auto Man Freq Offset 0.00000000 Hz Signal Track On Off</p>
5825	 <p>Agilent T Freq/Channel</p> <p>Ref 20 dBm Atten 20 dB Mkr1 5.827 50 GHz #Peak -2.70 dBm Log 10 dB/ Offst 11.8 dB LgAv</p> <p>M1 S2 S3 FC AL</p> <p>Ⓔ(f): FTun Swp</p> <p>Center 5.825 00 GHz Span 25 MHz #Res BW 100 kHz #VBW 300 kHz Sweep 2.4 ms (601 pts)</p> <p>Copyright 2000-2005 Agilent Technologies</p> <p>Center Freq 5.82500000 GHz Start Freq 5.81250000 GHz Stop Freq 5.83750000 GHz CF Step 2.50000000 MHz Auto Man Freq Offset 0.00000000 Hz Signal Track On Off</p>

Mode 7: IEEE 802.11n U-NII Band IV 20MHz Link Mode

5745	<p>Agilent R T Freq/Channel</p> <p>Ref 20 dBm Atten 20 dB Mkr1 5.742 12 GHz -3.45 dBm</p> <p>#Peak Log 10 dB/ Offst 11.8 dB</p> <p>LgAv</p> <p>M1 S2 S3 FC AL</p> <p>Ⓔ(f): FTun Swp</p> <p>Center 5.745 00 GHz Span 27 MHz #Res BW 100 kHz #VBW 300 kHz Sweep 2.6 ms (601 pts)</p> <p>Copyright 2000-2005 Agilent Technologies</p> <p>Center Freq 5.74500000 GHz Start Freq 5.73150000 GHz Stop Freq 5.75850000 GHz CF Step 2.70000000 MHz Auto Man Freq Offset 0.00000000 Hz Signal Track On Off</p>
5785	<p>Agilent T Freq/Channel</p> <p>Ref 20 dBm Atten 20 dB Mkr1 5.782 12 GHz -3.54 dBm</p> <p>#Peak Log 10 dB/ Offst 11.8 dB</p> <p>LgAv</p> <p>M1 S2 S3 FC AL</p> <p>Ⓔ(f): FTun Swp</p> <p>Center 5.785 00 GHz Span 27 MHz #Res BW 100 kHz #VBW 300 kHz Sweep 2.6 ms (601 pts)</p> <p>Copyright 2000-2005 Agilent Technologies</p> <p>Center Freq 5.78500000 GHz Start Freq 5.77150000 GHz Stop Freq 5.79850000 GHz CF Step 2.70000000 MHz Auto Man Freq Offset 0.00000000 Hz Signal Track On Off</p>
5825	<p>Agilent T Freq/Channel</p> <p>Ref 20 dBm Atten 20 dB Mkr1 5.819 64 GHz -4.27 dBm</p> <p>#Peak Log 10 dB/ Offst 11.8 dB</p> <p>LgAv</p> <p>M1 S2 S3 FC AL</p> <p>Ⓔ(f): FTun Swp</p> <p>Center 5.825 00 GHz Span 27 MHz #Res BW 100 kHz #VBW 300 kHz Sweep 2.6 ms (601 pts)</p> <p>Copyright 2000-2005 Agilent Technologies</p> <p>Center Freq 5.82500000 GHz Start Freq 5.81150000 GHz Stop Freq 5.83850000 GHz CF Step 2.70000000 MHz Auto Man Freq Offset 0.00000000 Hz Signal Track On Off</p>

Mode 8: IEEE 802.11n U-NII Band IV 40MHz Link Mode

5755	<p>Agilent T Freq/Channel</p> <p>Ref 20 dBm Atten 20 dB Mkr1 5.74333 GHz #Peak -6.78 dBm Log 10 dB/Offst 11.8 dB LgAv M1 S2 S3 FC AL E(f): FTun Swp</p> <p>Center 5.75500 GHz Span 50 MHz #Res BW 100 kHz #VBW 300 kHz Sweep 4.8 ms (601 pts)</p> <p>Copyright 2000-2005 Agilent Technologies</p> <p>Center Freq 5.75500000 GHz Start Freq 5.73000000 GHz Stop Freq 5.78000000 GHz CF Step 5.00000000 MHz Auto Man Freq Offset 0.00000000 Hz Signal Track On Off</p>
5795	<p>Agilent T Freq/Channel</p> <p>Ref 20 dBm Atten 20 dB Mkr1 5.79708 GHz #Peak -6.68 dBm Log 10 dB/Offst 11.8 dB LgAv M1 S2 S3 FC AL E(f): FTun Swp</p> <p>Center 5.79500 GHz Span 50 MHz #Res BW 100 kHz #VBW 300 kHz Sweep 4.8 ms (601 pts)</p> <p>Copyright 2000-2005 Agilent Technologies</p> <p>Center Freq 5.79500000 GHz Start Freq 5.77000000 GHz Stop Freq 5.82000000 GHz CF Step 5.00000000 MHz Auto Man Freq Offset 0.00000000 Hz Signal Track On Off</p>

9 Out of Band Conducted Emissions Measurement

9.1. Limit

In any 100 kHz bandwidth outside the frequency band in which the spread spectrum or digitally modulated intentional radiator is operating, the radio frequency power that is produced by the intentional radiator shall be at least 20 dB below that in the 100 kHz bandwidth within the band that contains the highest level of the desired power

9.2. Test Setup

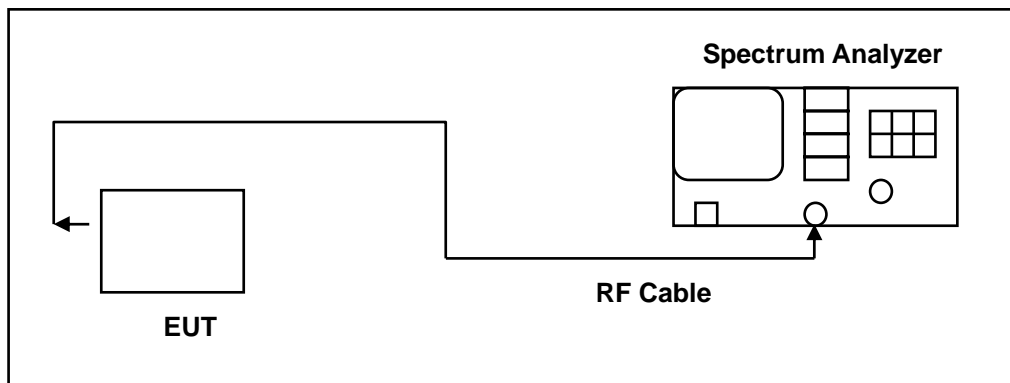

9.3. Test Instruments

Equipment	Manufacturer	Model Number	Serial Number	Cal. Date	Remark
Spectrum Analyzer	Agilent	E4445A	MY45300744	12/21/2011	(2)
Spectrum Analyzer	Agilent	E4408B	MY45107753	07/09/2012	(1)
Test Site	ATL	TE05	TE05	N.C.R.	-----

Remark: (1) Calibration period 1 year. (2) Calibration period 2 years. (3) Calibration period 3 years.

Note: N.C.R. = No Calibration Request.

9.4. Test Procedure

In any 100 kHz bandwidth outside the EUT pass band, the RF power produced by the modulation products of the spreading sequence, the information sequence, and the carrier frequency shall be at least 20 dB below that of the maximum in-band 100 kHz emission, antenna output of the EUT was coupled directly to spectrum analyzer; if an external attenuator and/or cable was used, these losses are compensated for with the analyzer OFFSET function.

All other types of emissions from the EUT shall meet the general limits for radiated frequencies outside the pass band.

The test was performed at 3 channels (Channel 1, 6, 11)

9.5. Test Graphs

Mode 2: IEEE 802.11b Link Mode

2412



2437



2462



Mode 3: IEEE 802.11g Link Mode

2412

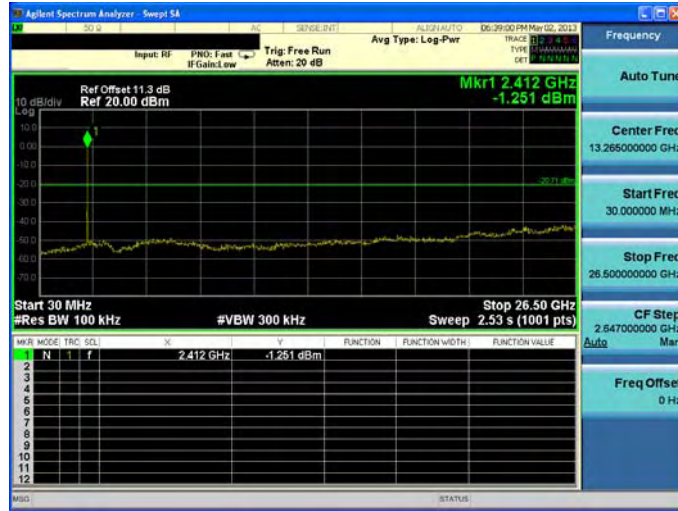

2437



2462



Mode 4: IEEE 802.11n 2.4GHz 20MHz Link Mode

2412



2437



2462

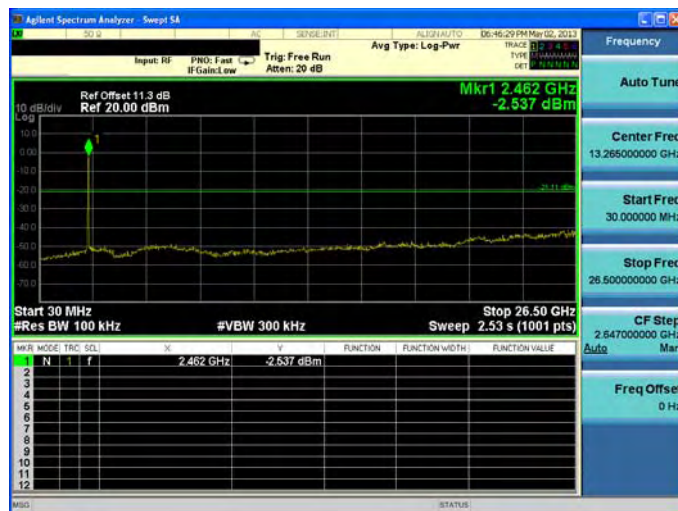

Mode 5: IEEE 802.11n 2.4GHz 40MHz Link Mode

2422

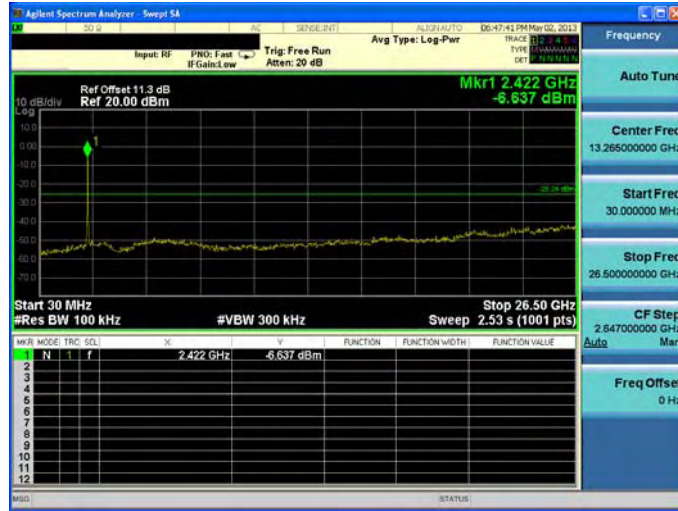

2437



2452



Mode 6: IEEE 802.11a U-NII Band IV Link Mode

5745	<p>Copyright 2000-2007 Agilent Technologies</p>
5785	<p>Copyright 2000-2007 Agilent Technologies</p>
5825	<p>Copyright 2000-2007 Agilent Technologies</p>

Mode 7: IEEE 802.11n U-NII Band IV 20MHz Link Mode

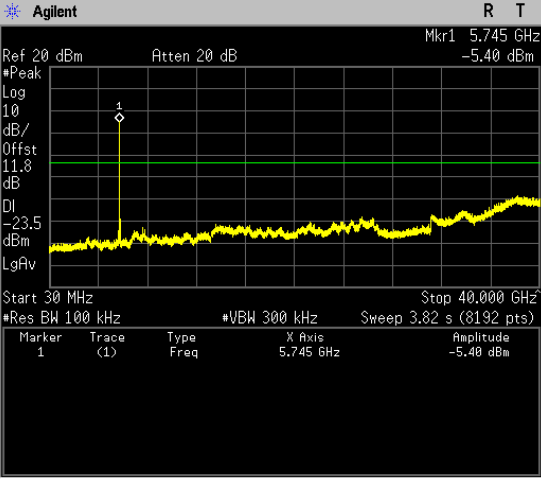
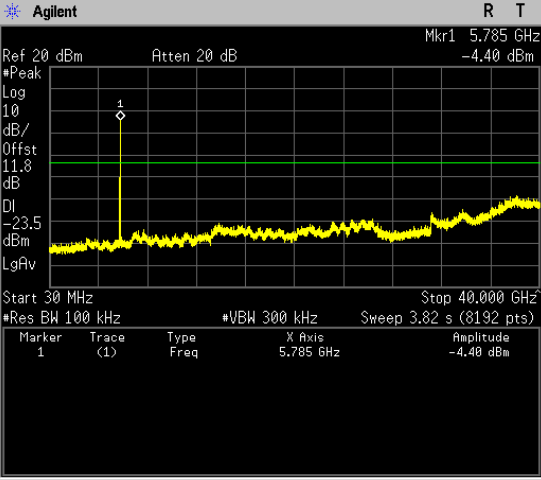
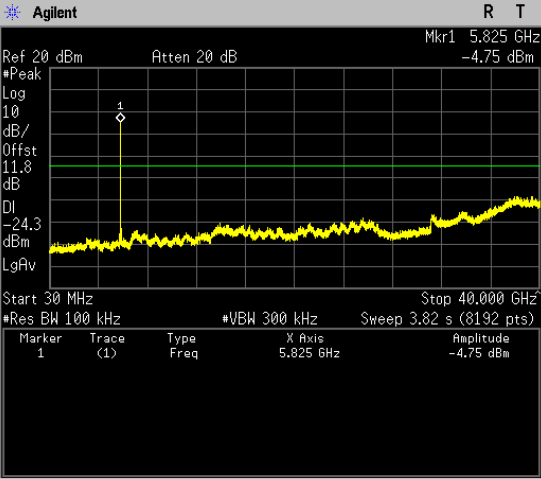
<p>5745</p>	 <p>Copyright 2000-2007 Agilent Technologies</p>
<p>5785</p>	 <p>Copyright 2000-2007 Agilent Technologies</p>
<p>5825</p>	 <p>Copyright 2000-2007 Agilent Technologies</p>

Mode 8: IEEE 802.11n U-NII Band IV 40MHz Link Mode

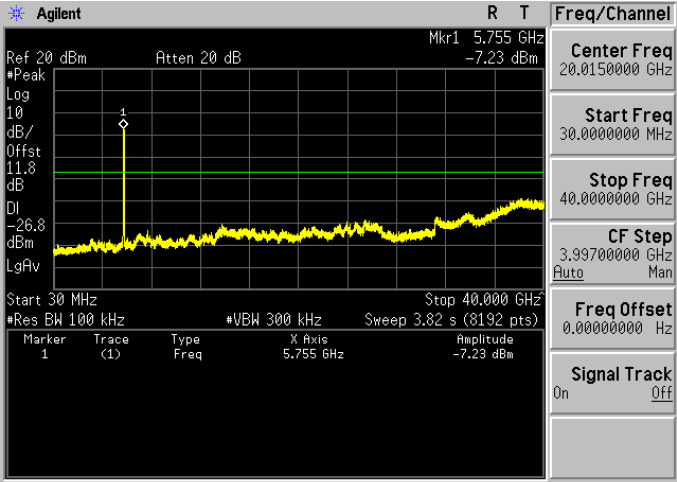
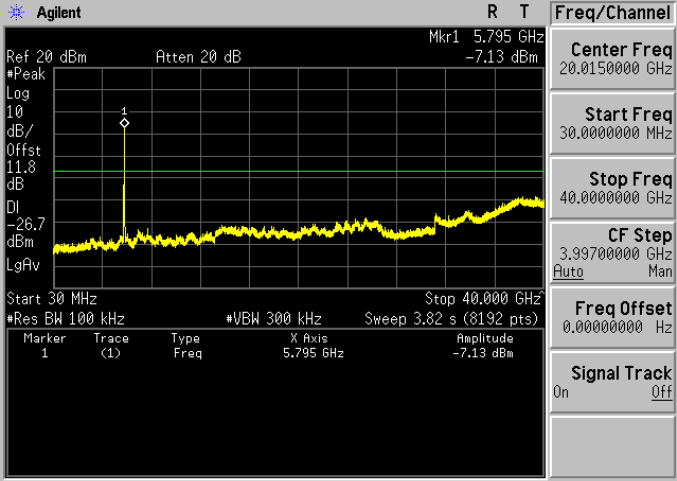
5755	 <p>Copyright 2000-2007 Agilent Technologies</p>
5795	 <p>Copyright 2000-2007 Agilent Technologies</p>

10 Band Edges Measurement

10.1.Limit

In any 100 kHz bandwidth outside the intentional radiation frequency band, the radio frequency power shall be at least 20 dB below the highest level of the radiated power. In addition, radiated emissions which fall in the restricted bands must also comply with the radiated emission limits.

10.2.Test Setup

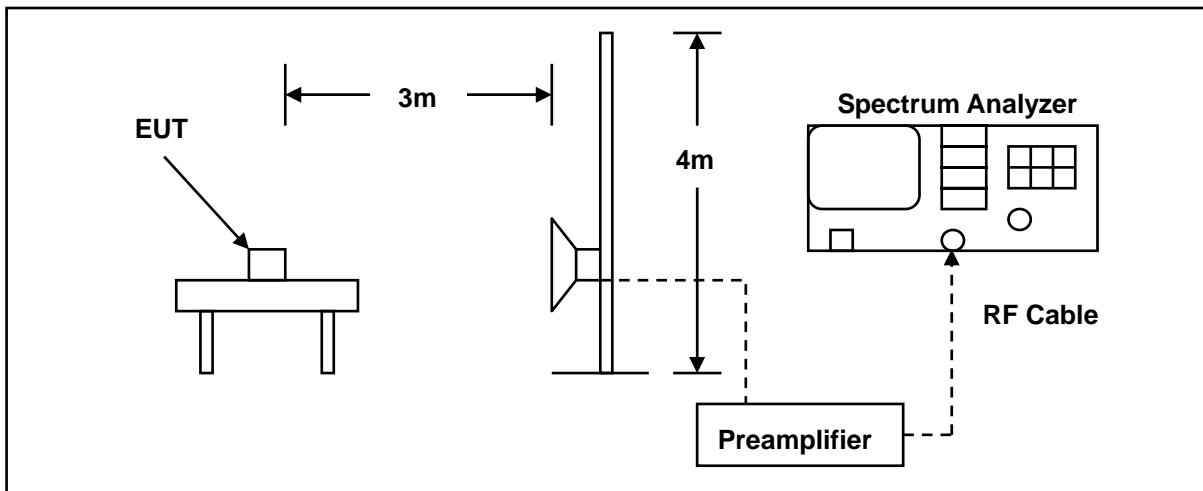

10.3.Test Instruments

3 Meter Chamber					
Equipment	Manufacturer	Model Number	Serial Number	Cal. Date	Remark
RF Pre-selector	Agilent	N9039A	MY46520256	01/16/2012	(2)
Spectrum Analyzer	Agilent	E4446A	MY46180578	01/21/2013	(1)
Pre Amplifier	Agilent	8449B	3008A02237	02/21/2013	(1)
Pre Amplifier	Agilent	8447D	2944A10961	02/21/2013	(1)
Broadband Antenna (30MHz~1GHz)	SCHWARZBECK MESS-ELEKTRONIK	VULB9163	9163-270	06/29/2012	(1)
Horn Antenna (1~18GHz)	SCHWARZBECK MESS-ELEKTRONIK	BBHA9120D	9120D-550	06/15/2012	(1)
Test Site	ATL	TE01	888001	08/28/2012	(1)

Remark: (1) Calibration period 1 year. (2) Calibration period 2 years. (3) Calibration period 3 years.

Note: N.C.R. = No Calibration Request.

10.4. Test Procedure

The EUT was setup to ANSI C63.4, 2009; tested to DTS test procedure of Oct 2012 KDB558074 for compliance to FCC 47CFR 15.247 requirements.

The emissions on the harmonics frequencies, the limits, and the margin of compliance are presented. These tests were made when the transmitter was in full radiated power. The additional test was performed to show compliance with the requirement at the band-edge frequency 2483.5 MHz and up to 2500 MHz and at 2390.0 MHz.

The transmitter was configured with the worst case antenna and setup to transmit at the highest channel. Then the field strength was measured at 2483.5 MHz.

The transmitter was then configured with the worst case antenna and setup to transmit at the lowest channel. Then the field strength was measured at 2390.0 MHz. These tests were performed at 4 different bit rates.

For measurements the resolution bandwidth is set to 1 MHz, and then the video bandwidth is set to 1 MHz for peak measurements and 10 Hz for average measurements.

10.5. Test Result

Standard:	FCC Part 15C	Test Distance:	3m
Test item:	Radiated Emission	Power:	AC 120V/60Hz
Model Number:	PS2 Speaker	Temp.(°C)/Hum.(%RH):	26(°C)/60%RH
Mode:	2	Date:	04/30/2013
Frequency:	2412 MHz	Test By:	Fly Lu
Ant.Polar.:	Horizontal		

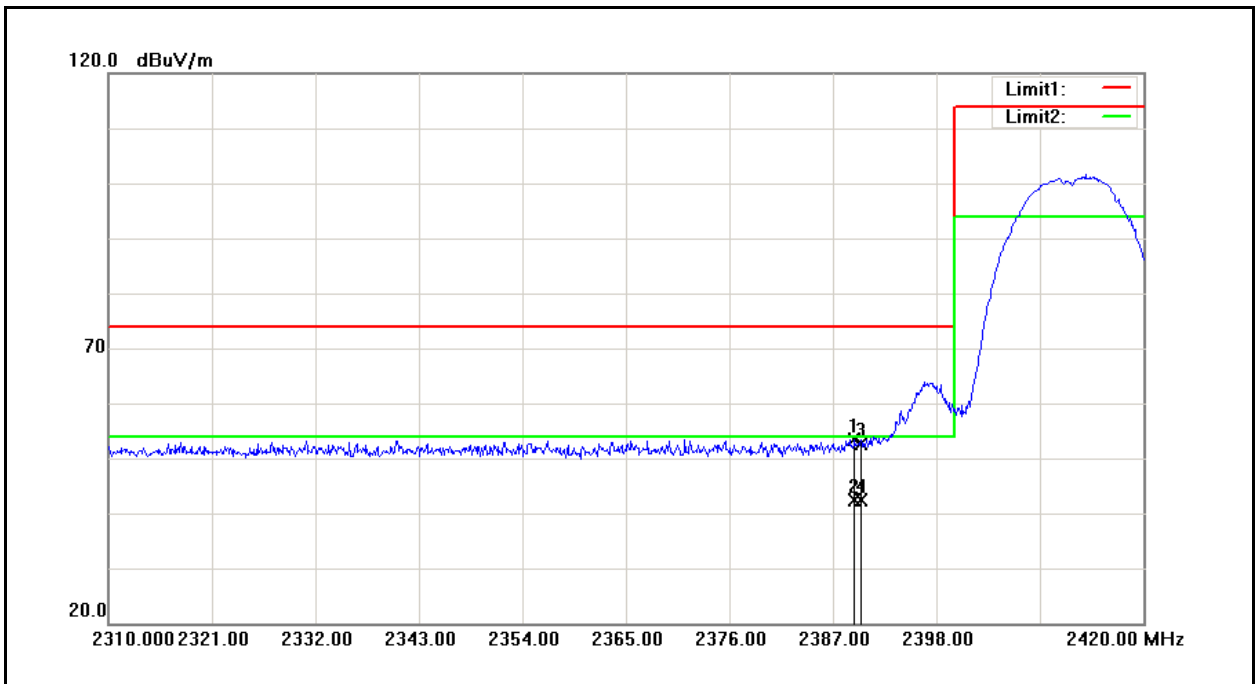

No.	Frequency (MHz)	Reading (dBuV)	Correct Factor (dB/m)	Result (dBuV/m)	Limit (dBuV/m)	Margin (dB)	Remark
1	2389.310	49.47	3.88	53.35	74.00	-20.65	peak
2	2389.310	38.39	3.88	42.27	54.00	-11.73	AVG
3	2390.000	48.76	3.88	52.64	74.00	-21.36	peak
4	2390.000	38.41	3.88	42.29	54.00	-11.71	AVG

Standard:	FCC Part 15C	Test Distance:	3m
Test item:	Radiated Emission	Power:	AC 120V/60Hz
Model Number:	PS2 Speaker	Temp.(°C)/Hum.(%RH):	26(°C)/60%RH
Mode:	2	Date:	04/30/2013
Frequency:	2412 MHz	Test By:	Fly Lu
Ant.Polar.:	Vertical		

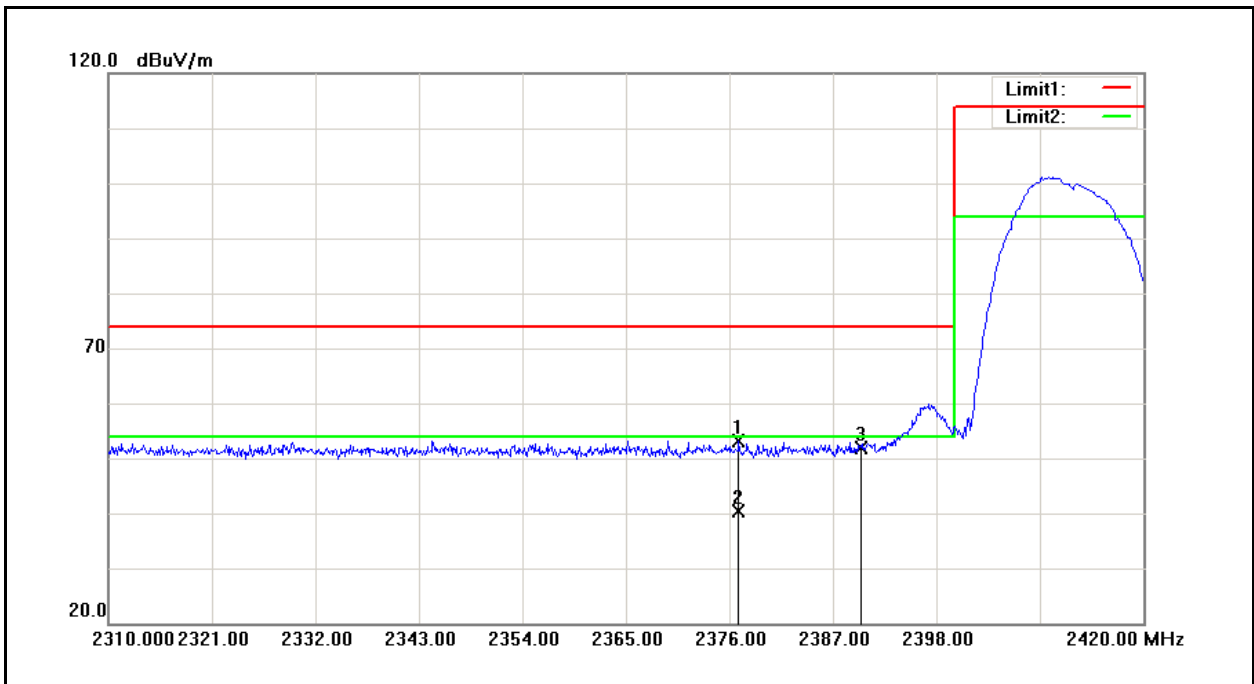

No.	Frequency (MHz)	Reading (dBuV)	Correct Factor (dB/m)	Result (dBuV/m)	Limit (dBuV/m)	Margin (dB)	Remark
1	2376.990	49.37	3.79	53.16	74.00	-20.84	peak
2	2376.990	36.55	3.79	40.34	54.00	-13.66	AVG
3	2390.000	47.95	3.88	51.83	74.00	-22.17	peak

Standard:	FCC Part 15C	Test Distance:	3m
Test item:	Radiated Emission	Power:	AC 120V/60Hz
Model Number:	PS2 Speaker	Temp.(°C)/Hum.(%RH):	26(°C)/60%RH
Mode:	2	Date:	04/30/2013
Frequency:	2462 MHz	Test By:	Fly Lu
Ant.Polar.:	Horizontal		

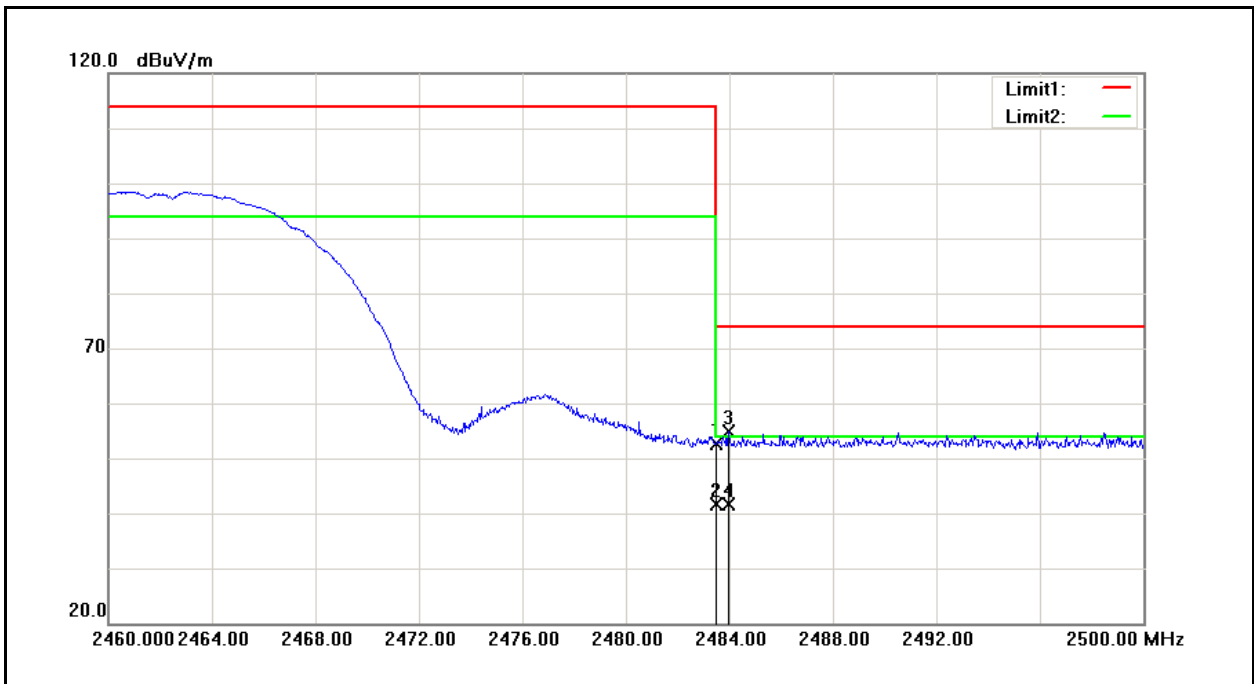

No.	Frequency (MHz)	Reading (dBuV)	Correct Factor (dB/m)	Result (dBuV/m)	Limit (dBuV/m)	Margin (dB)	Remark
1	2483.500	48.25	4.50	52.75	74.00	-21.25	peak
2	2483.500	37.08	4.50	41.58	54.00	-12.42	AVG
3	2483.960	50.26	4.51	54.77	74.00	-19.23	peak
4	2483.960	37.01	4.51	41.52	54.00	-12.48	AVG

Standard:	FCC Part 15C	Test Distance:	3m
Test item:	Radiated Emission	Power:	AC 120V/60Hz
Model Number:	PS2 Speaker	Temp.(°C)/Hum.(%RH):	26(°C)/60%RH
Mode:	2	Date:	04/30/2013
Frequency:	2462 MHz	Test By:	Fly Lu
Ant.Polar.:	Vertical		

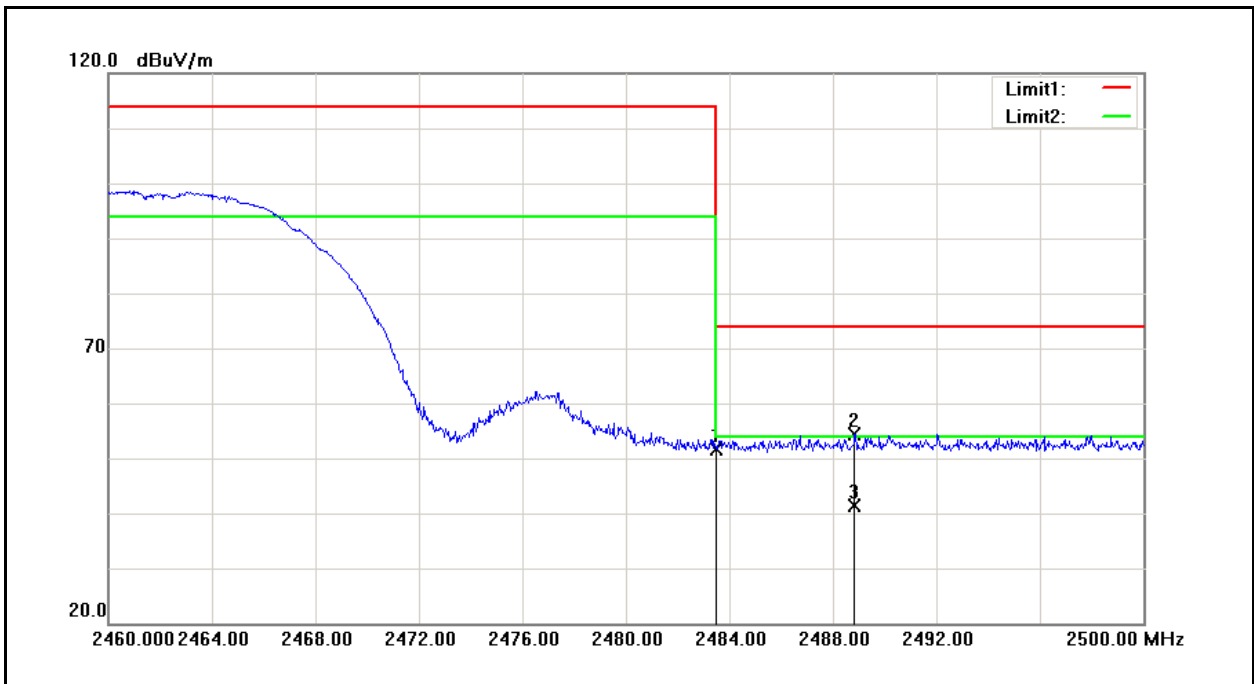

No.	Frequency (MHz)	Reading (dBuV)	Correct Factor (dB/m)	Result (dBuV/m)	Limit (dBuV/m)	Margin (dB)	Remark
1	2483.500	47.08	4.50	51.58	74.00	-22.42	peak
2	2488.840	49.81	4.55	54.36	74.00	-19.64	peak
3	2488.840	36.87	4.55	41.42	54.00	-12.58	AVG

Standard:	FCC Part 15C	Test Distance:	3m
Test item:	Radiated Emission	Power:	AC 120V/60Hz
Model Number:	PS2 Speaker	Temp.(°C)/Hum.(%RH):	26(°C)/60%RH
Mode:	3	Date:	04/30/2013
Frequency:	2412 MHz	Test By:	Fly Lu
Ant.Polar.:	Horizontal		

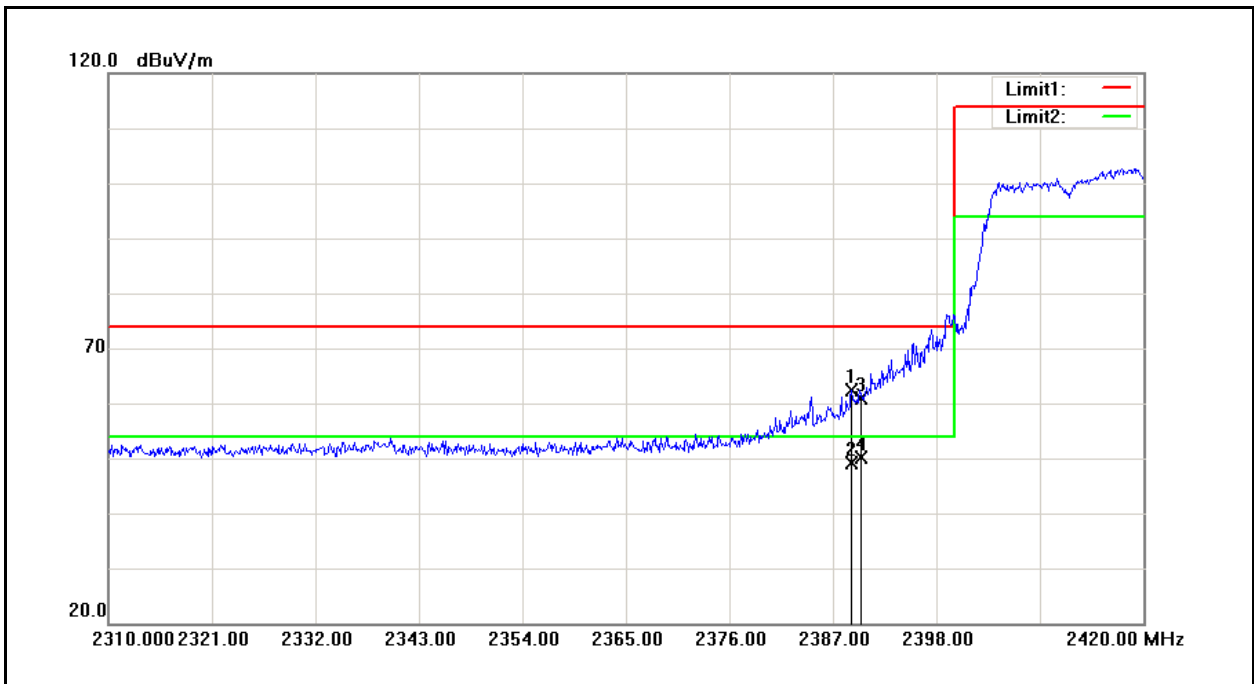

No.	Frequency (MHz)	Reading (dBuV)	Correct Factor (dB/m)	Result (dBuV/m)	Limit (dBuV/m)	Margin (dB)	Remark
1	2388.980	58.38	3.88	62.26	74.00	-11.74	peak
2	2388.980	45.26	3.88	49.14	54.00	-4.86	AVG
3	2390.000	56.89	3.88	60.77	74.00	-13.23	peak
4	2390.000	46.28	3.88	50.16	54.00	-3.84	AVG

Standard:	FCC Part 15C	Test Distance:	3m
Test item:	Radiated Emission	Power:	AC 120V/60Hz
Model Number:	PS2 Speaker	Temp.(°C)/Hum.(%RH):	26(°C)/60%RH
Mode:	3	Date:	04/30/2013
Frequency:	2412 MHz	Test By:	Fly Lu
Ant.Polar.:	Vertical		

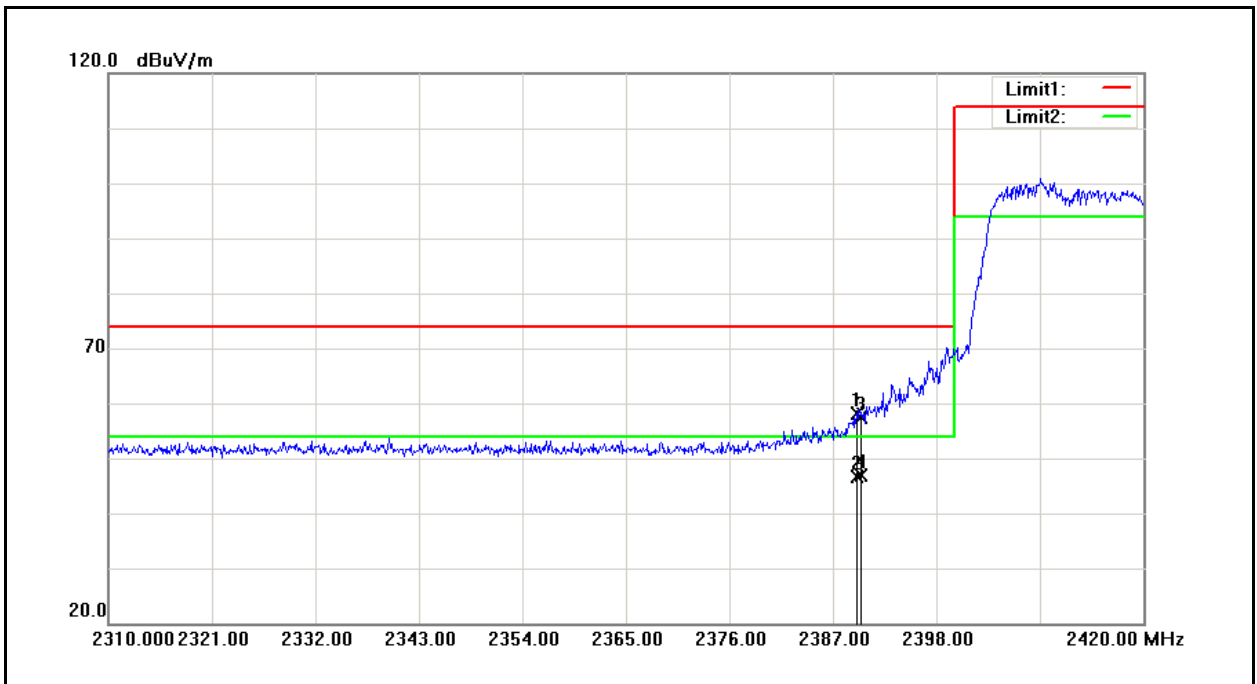

No.	Frequency (MHz)	Reading (dBuV)	Correct Factor (dB/m)	Result (dBuV/m)	Limit (dBuV/m)	Margin (dB)	Remark
1	2389.530	54.36	3.88	58.24	74.00	-15.76	peak
2	2389.530	42.73	3.88	46.61	54.00	-7.39	AVG
3	2390.000	53.61	3.88	57.49	74.00	-16.51	peak
4	2390.000	43.07	3.88	46.95	54.00	-7.05	AVG

Standard:	FCC Part 15C	Test Distance:	3m
Test item:	Radiated Emission	Power:	AC 120V/60Hz
Model Number:	PS2 Speaker	Temp.(°C)/Hum.(%RH):	26(°C)/60%RH
Mode:	3	Date:	04/30/2013
Frequency:	2462 MHz	Test By:	Fly Lu
Ant.Polar.:	Horizontal		

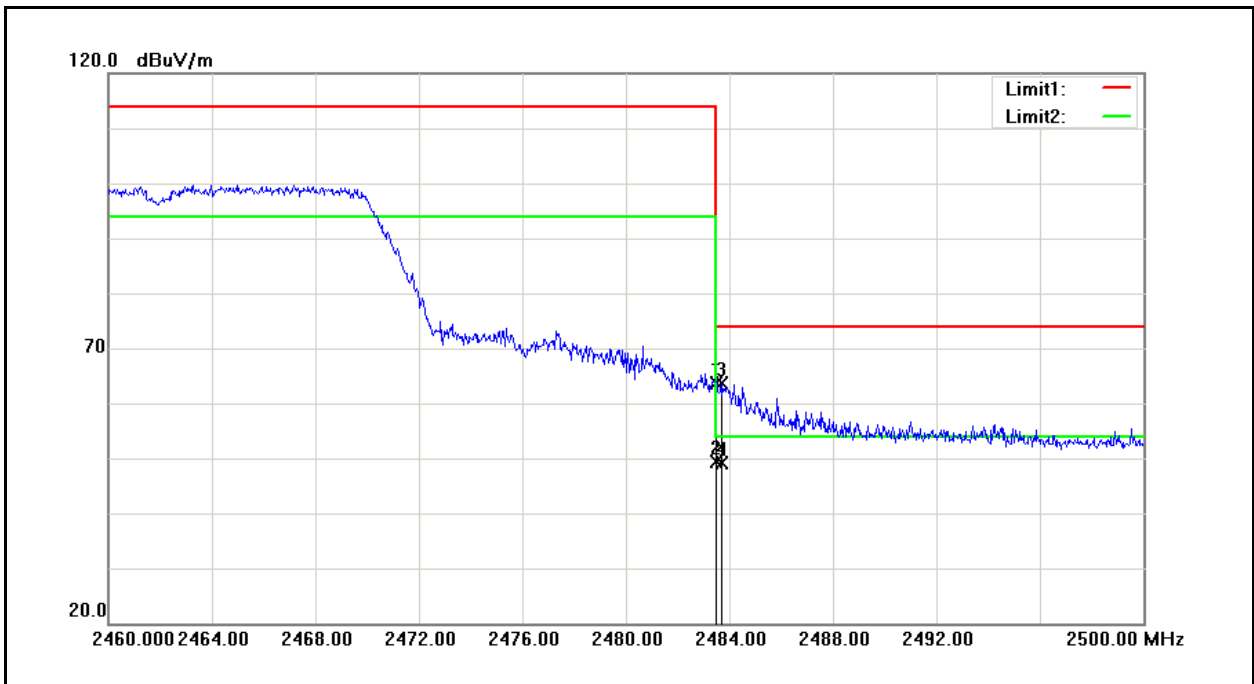

No.	Frequency (MHz)	Reading (dBuV)	Correct Factor (dB/m)	Result (dBuV/m)	Limit (dBuV/m)	Margin (dB)	Remark
1	2483.500	59.15	4.50	63.65	74.00	-10.35	peak
2	2483.500	44.98	4.50	49.48	54.00	-4.52	AVG
3	2483.680	59.09	4.50	63.59	74.00	-10.41	peak
4	2483.680	44.74	4.50	49.24	54.00	-4.76	AVG

Standard:	FCC Part 15C	Test Distance:	3m
Test item:	Radiated Emission	Power:	AC 120V/60Hz
Model Number:	PS2 Speaker	Temp.(°C)/Hum.(%RH):	26(°C)/60%RH
Mode:	3	Date:	04/30/2013
Frequency:	2462 MHz	Test By:	Fly Lu
Ant.Polar.:	Vertical		

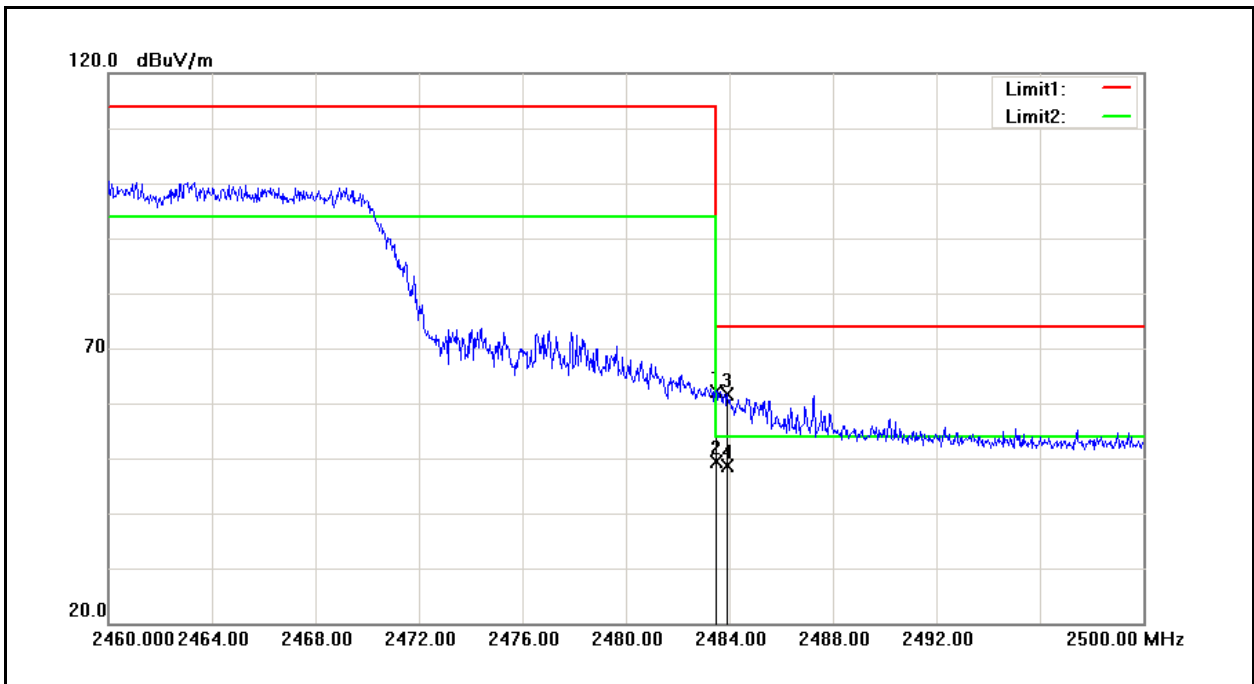

No.	Frequency (MHz)	Reading (dBuV)	Correct Factor (dB/m)	Result (dBuV/m)	Limit (dBuV/m)	Margin (dB)	Remark
1	2483.500	57.53	4.50	62.03	74.00	-11.97	peak
2	2483.500	44.97	4.50	49.47	54.00	-4.53	AVG
3	2483.920	57.13	4.51	61.64	74.00	-12.36	peak
4	2483.920	44.11	4.51	48.62	54.00	-5.38	AVG

Standard:	FCC Part 15C	Test Distance:	3m
Test item:	Radiated Emission	Power:	AC 120V/60Hz
Model Number:	PS2 Speaker	Temp.(°C)/Hum.(%RH):	26(°C)/60%RH
Mode:	4	Date:	04/30/2013
Frequency:	2412 MHz	Test By:	Fly Lu
Ant.Polar.:	Horizontal		

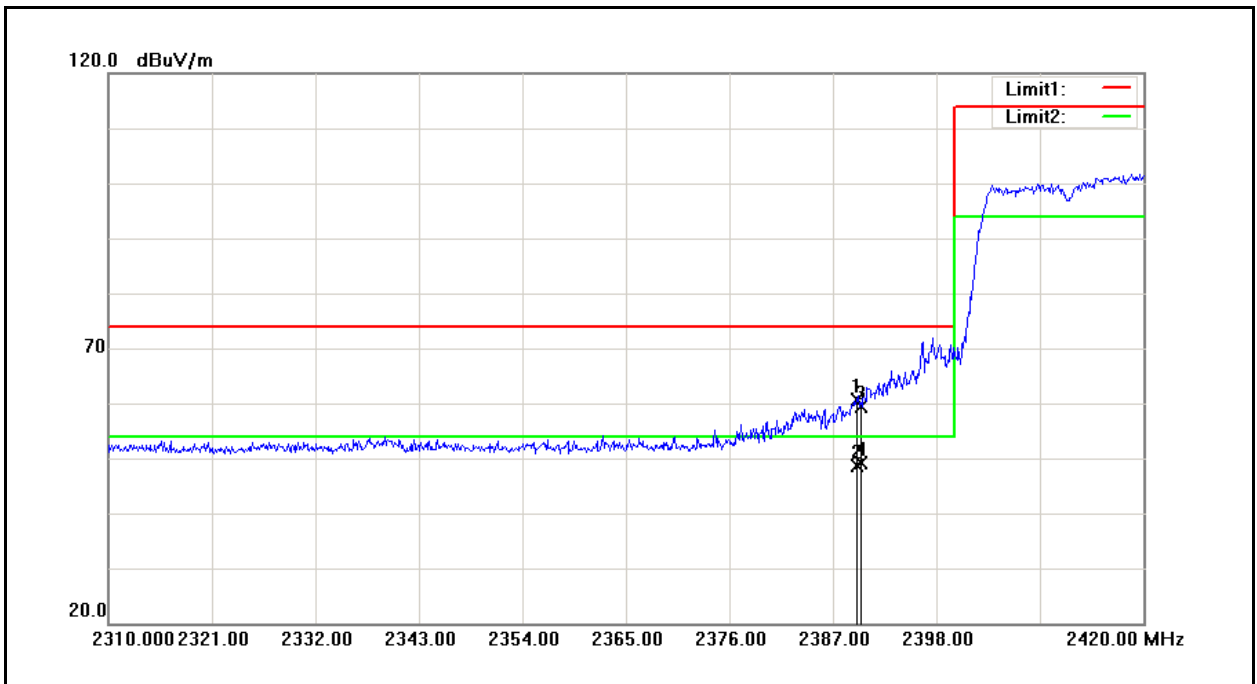

No.	Frequency (MHz)	Reading (dBuV)	Correct Factor (dB/m)	Result (dBuV/m)	Limit (dBuV/m)	Margin (dB)	Remark
1	2389.530	56.65	3.88	60.53	74.00	-13.47	peak
2	2389.530	44.63	3.88	48.51	54.00	-5.49	AVG
3	2390.000	55.45	3.88	59.33	74.00	-14.67	peak
4	2390.000	45.20	3.88	49.08	54.00	-4.92	AVG

Standard:	FCC Part 15C	Test Distance:	3m
Test item:	Radiated Emission	Power:	AC 120V/60Hz
Model Number:	PS2 Speaker	Temp.(°C)/Hum.(%RH):	26(°C)/60%RH
Mode:	4	Date:	04/30/2013
Frequency:	2412 MHz	Test By:	Fly Lu
Ant.Polar.:	Vertical		

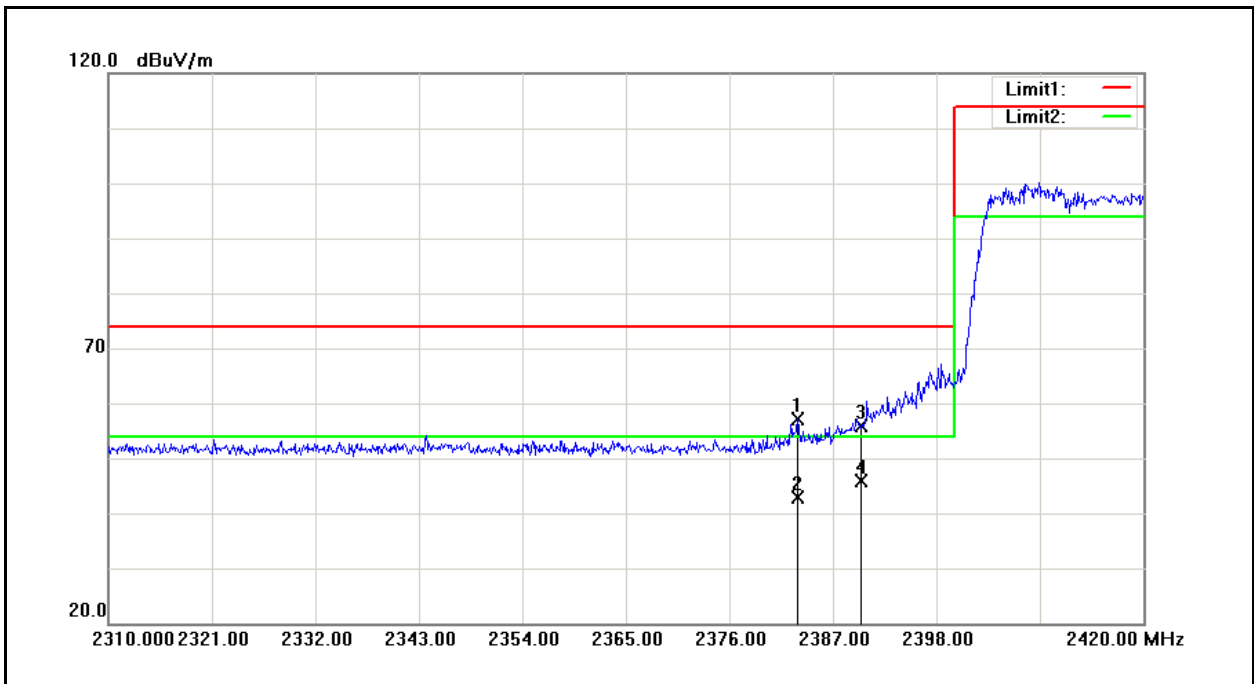

No.	Frequency (MHz)	Reading (dBuV)	Correct Factor (dB/m)	Result (dBuV/m)	Limit (dBuV/m)	Margin (dB)	Remark
1	2383.260	53.22	3.83	57.05	74.00	-16.95	peak
2	2383.260	39.09	3.83	42.92	54.00	-11.08	AVG
3	2390.000	52.05	3.88	55.93	74.00	-18.07	peak
4	2390.000	41.91	3.88	45.79	54.00	-8.21	AVG

Standard:	FCC Part 15C	Test Distance:	3m
Test item:	Radiated Emission	Power:	AC 120V/60Hz
Model Number:	PS2 Speaker	Temp.(°C)/Hum.(%RH):	26(°C)/60%RH
Mode:	4	Date:	04/30/2013
Frequency:	2462 MHz	Test By:	Fly Lu
Ant.Polar.:	Horizontal		

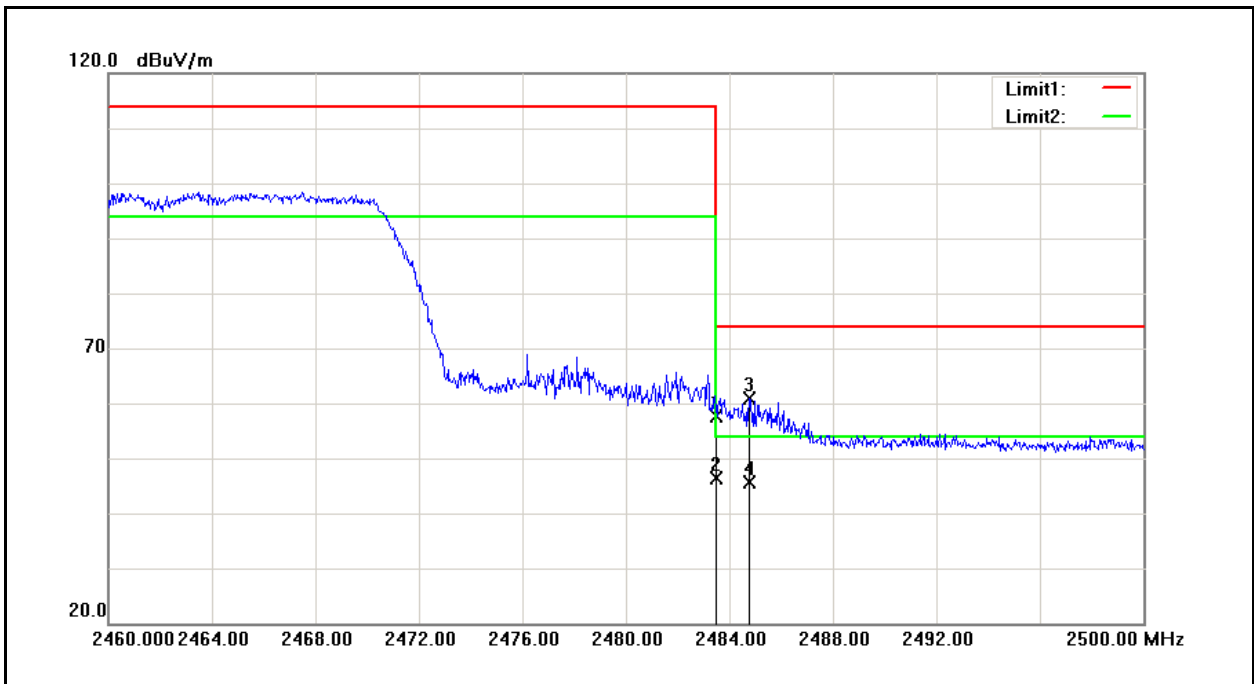

No.	Frequency (MHz)	Reading (dBuV)	Correct Factor (dB/m)	Result (dBuV/m)	Limit (dBuV/m)	Margin (dB)	Remark
1	2483.500	53.10	4.50	57.60	74.00	-16.40	peak
2	2483.500	42.00	4.50	46.50	54.00	-7.50	AVG
3	2484.760	56.48	4.51	60.99	74.00	-13.01	peak
4	2484.760	41.21	4.51	45.72	54.00	-8.28	AVG

Standard:	FCC Part 15C	Test Distance:	3m
Test item:	Radiated Emission	Power:	AC 120V/60Hz
Model Number:	PS2 Speaker	Temp.(°C)/Hum.(%RH):	26(°C)/60%RH
Mode:	4	Date:	04/30/2013
Frequency:	2462 MHz	Test By:	Fly Lu
Ant.Polar.:	Vertical		

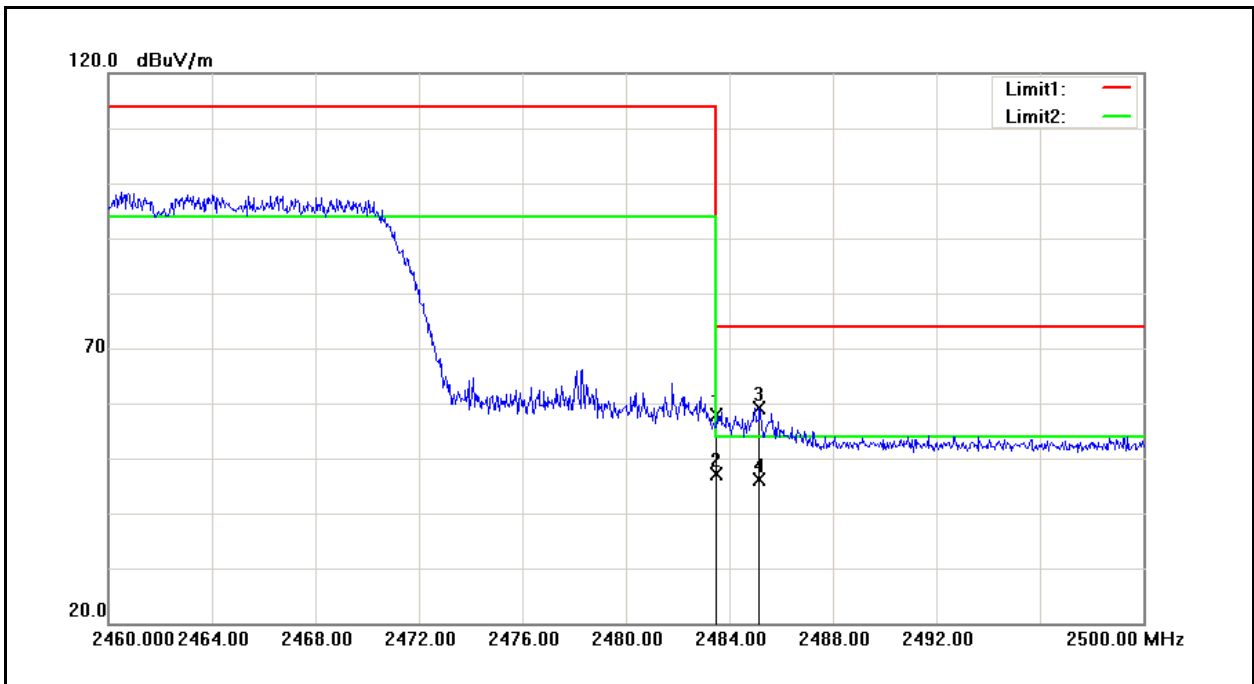

No.	Frequency (MHz)	Reading (dBuV)	Correct Factor (dB/m)	Result (dBuV/m)	Limit (dBuV/m)	Margin (dB)	Remark
1	2483.500	53.49	4.50	57.99	74.00	-16.01	peak
2	2483.500	42.69	4.50	47.19	54.00	-6.81	AVG
3	2485.160	54.61	4.52	59.13	74.00	-14.87	peak
4	2485.160	41.59	4.52	46.11	54.00	-7.89	AVG

Standard:	FCC Part 15C	Test Distance:	3m
Test item:	Radiated Emission	Power:	AC 120V/60Hz
Model Number:	PS2 Speaker	Temp.(°C)/Hum.(%RH):	26(°C)/60%RH
Mode:	5	Date:	04/30/2013
Frequency:	2422 MHz	Test By:	Fly Lu
Ant.Polar.:	Horizontal		

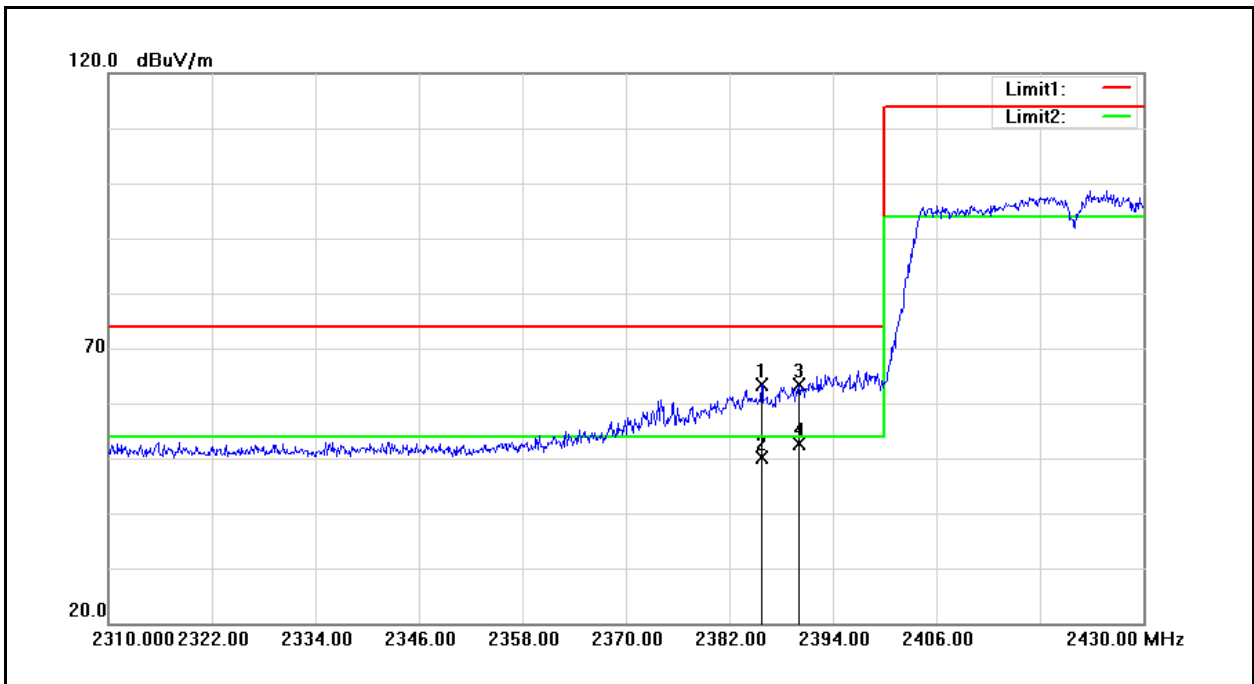

No.	Frequency (MHz)	Reading (dBuV)	Correct Factor (dB/m)	Result (dBuV/m)	Limit (dBuV/m)	Margin (dB)	Remark
1	2385.720	59.57	3.85	63.42	74.00	-10.58	peak
2	2385.720	46.26	3.85	50.11	54.00	-3.89	AVG
3	2390.000	59.43	3.88	63.31	74.00	-10.69	peak
4	2390.000	48.86	3.88	52.74	54.00	-1.26	AVG

Standard:	FCC Part 15C	Test Distance:	3m
Test item:	Radiated Emission	Power:	AC 120V/60Hz
Model Number:	PS2 Speaker	Temp.(°C)/Hum.(%RH):	26(°C)/60%RH
Mode:	5	Date:	04/30/2013
Frequency:	2422 MHz	Test By:	Fly Lu
Ant.Polar.:	Vertical		

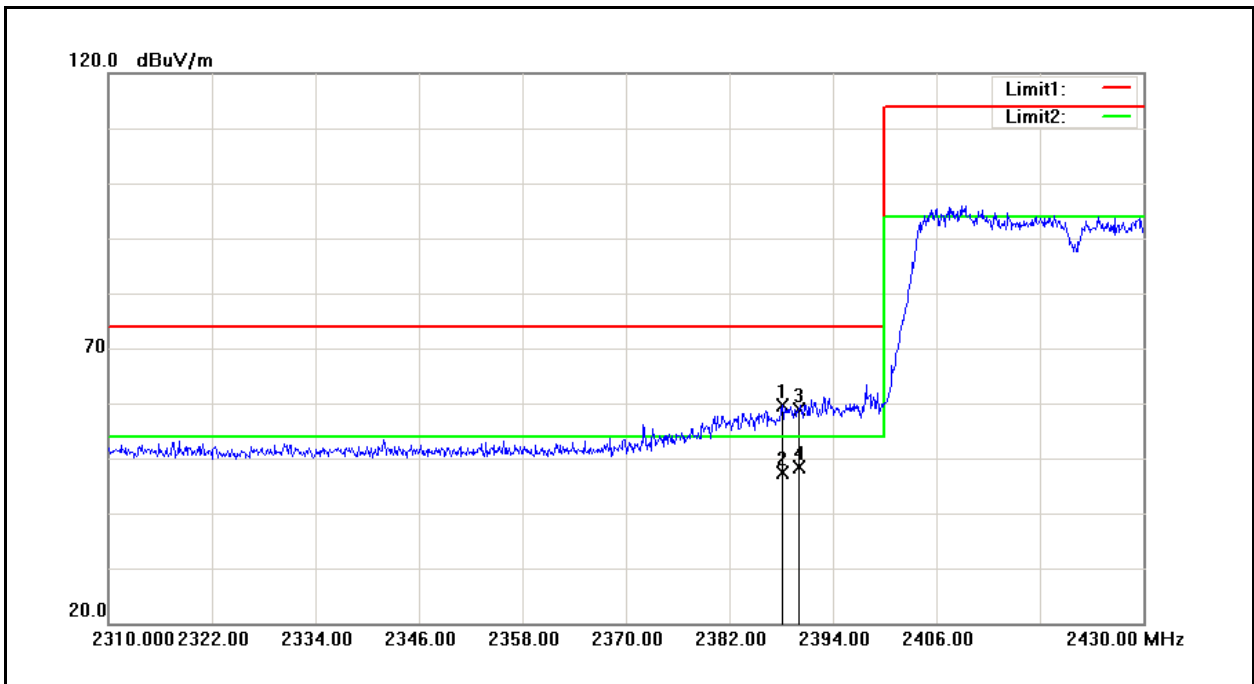

No.	Frequency (MHz)	Reading (dBuV)	Correct Factor (dB/m)	Result (dBuV/m)	Limit (dBuV/m)	Margin (dB)	Remark
1	2388.120	55.72	3.86	59.58	74.00	-14.42	peak
2	2388.120	43.60	3.86	47.46	54.00	-6.54	AVG
3	2390.000	54.89	3.88	58.77	74.00	-15.23	peak
4	2390.000	44.61	3.88	48.49	54.00	-5.51	AVG

Standard:	FCC Part 15C	Test Distance:	3m
Test item:	Radiated Emission	Power:	AC 120V/60Hz
Model Number:	PS2 Speaker	Temp.(°C)/Hum.(%RH):	26(°C)/60%RH
Mode:	5	Date:	04/30/2013
Frequency:	2452 MHz	Test By:	Fly Lu
Ant.Polar.:	Horizontal		

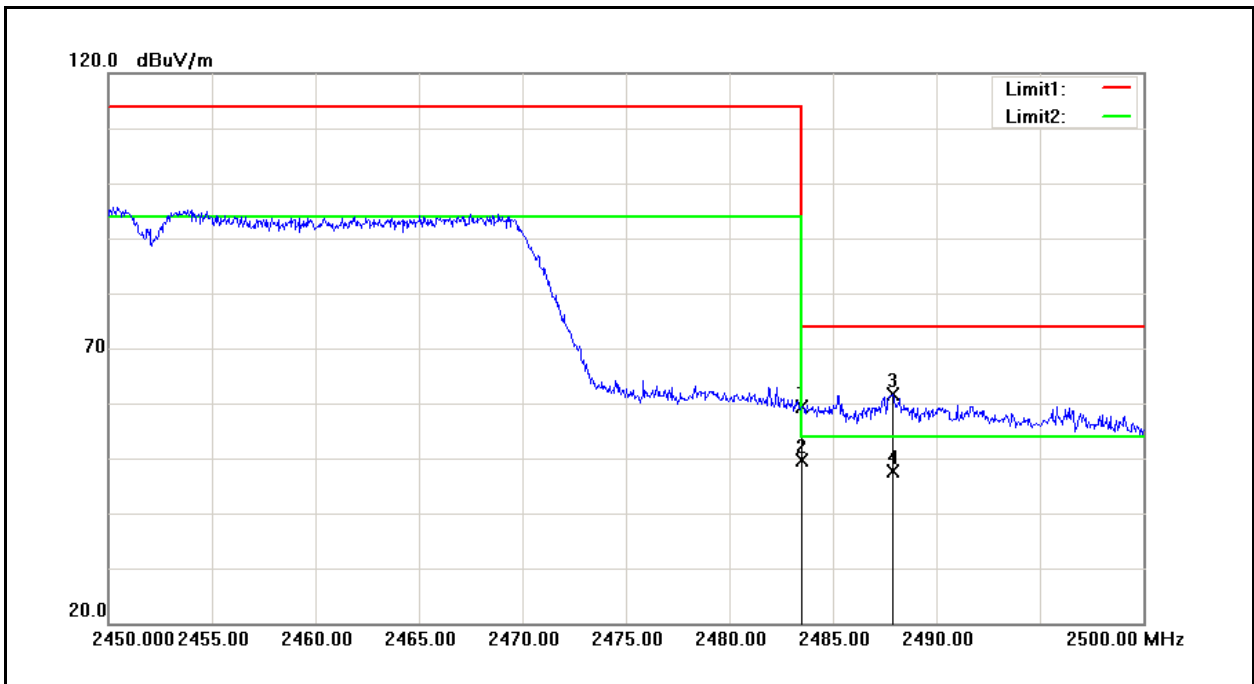

No.	Frequency (MHz)	Reading (dBuV)	Correct Factor (dB/m)	Result (dBuV/m)	Limit (dBuV/m)	Margin (dB)	Remark
1	2483.500	54.85	4.50	59.35	74.00	-14.65	peak
2	2483.500	45.03	4.50	49.53	54.00	-4.47	AVG
3	2487.900	57.03	4.53	61.56	74.00	-12.44	peak
4	2487.900	42.99	4.53	47.52	54.00	-6.48	AVG

Standard:	FCC Part 15C	Test Distance:	3m
Test item:	Radiated Emission	Power:	AC 120V/60Hz
Model Number:	PS2 Speaker	Temp.(°C)/Hum.(%RH):	26(°C)/60%RH
Mode:	5	Date:	04/30/2013
Frequency:	2452 MHz	Test By:	Fly Lu
Ant.Polar.:	Vertical		

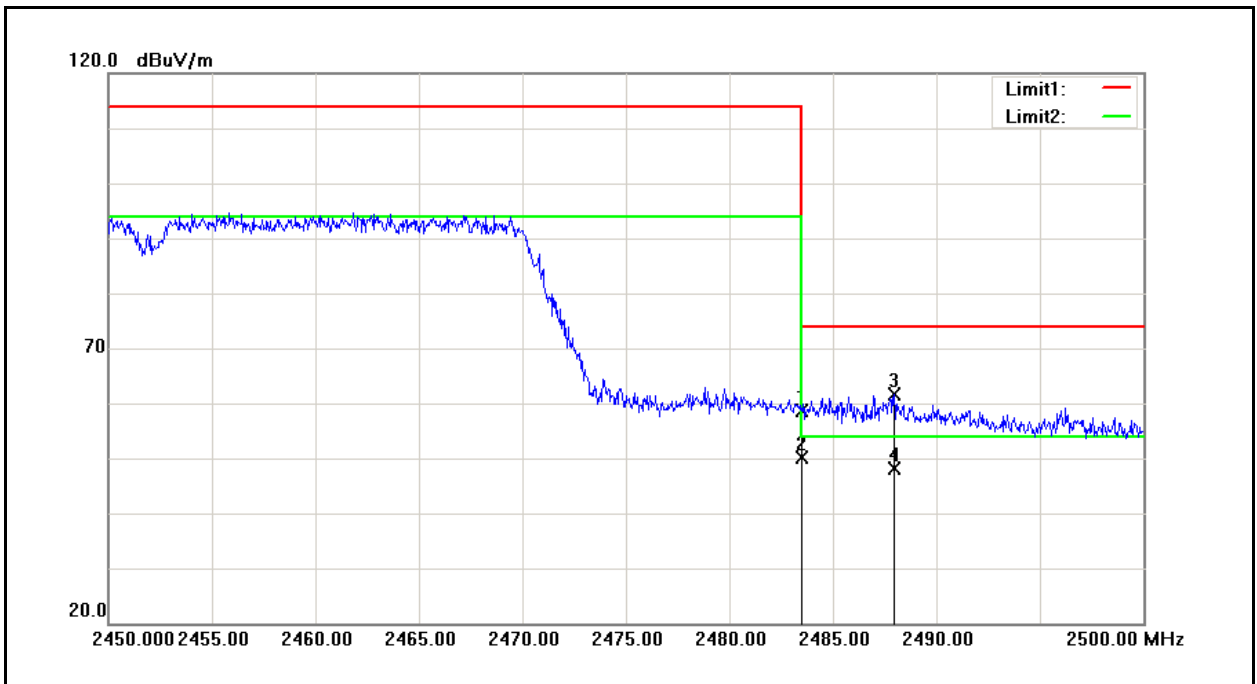

No.	Frequency (MHz)	Reading (dBuV)	Correct Factor (dB/m)	Result (dBuV/m)	Limit (dBuV/m)	Margin (dB)	Remark
1	2483.500	54.22	4.50	58.72	74.00	-15.28	peak
2	2483.500	45.60	4.50	50.10	54.00	-3.90	AVG
3	2487.950	57.10	4.53	61.63	74.00	-12.37	peak
4	2487.950	43.72	4.53	48.25	54.00	-5.75	AVG

11 Antenna Measurement

11.1.Limit

For intentional device, according to 15.203, an intentional radiator shall be designed to ensure that no antenna other than that furnished by the responsible party shall be used with the device.

And According to 15.247 (b), if transmitting antennas of directional gain greater than 6 dBi are used, the power shall be reduced by the amount in dB that the directional gain of the antenna exceeds 6dBi.

11.2.Antenna Connector Construction

The antenna used in this product is PIFA antenna. And the maximum gain of the antenna is listed below.

Frequency Band	ANTL	ANTR
IEEE 802.11b / 802.11g IEEE 802.11n (2.4GHz) 20MHz / 40MHz	2.78 dBi	3.37 dBi
IEEE 802.11a IEEE 802.11n (5GHz) 20MHz / 40MHz U-NII Band IV	3.69 dBi	5.36 dBi