

FCC Test Report

Report No.: RF180918C26-2

FCC ID: 2AAWQ-CAPRICA5

Test Model: Caprica5

Received Date: Sep. 18, 2018

Test Date: Jun. 18 ~ Oct. 03, 2019

Issued Date: Oct. 18, 2019

Applicant: Phorus, Inc.

Address: 5220 Las Virgenes Road Calabasas California United States 91302

Issued By: Bureau Veritas Consumer Products Services (H.K.) Ltd., Taoyuan Branch
Lin Kou Laboratories

Lab Address: No. 47-2, 14th Ling, Chia Pau Vil., Lin Kou Dist., New Taipei City, Taiwan

Test Location: B2F., No.215, Sec. 3, Beixin Rd., Xindian Dist., New Taipei City 231, Taiwan

**FCC Registration /
Designation Number:** 427177 / TW0011



This report is for your exclusive use. Any copying or replication of this report to or for any other person or entity, or use of our name or trademark, is permitted only with our prior written permission. This report sets forth our findings solely with respect to the test samples identified herein. The results set forth in this report are not indicative or representative of the quality or characteristics of the lot from which a test sample was taken or any similar or identical product unless specifically and expressly noted. Our report includes all of the tests requested by you and the results thereof based upon the information that you provided to us. You have 60 days from date of issuance of this report to notify us of any material error or omission caused by our negligence, provided, however, that such notice shall be in writing and shall specifically address the issue you wish to raise. A failure to raise such issue within the prescribed time shall constitute your unqualified acceptance of the completeness of this report, the tests conducted and the correctness of the report contents. Unless specific mention, the uncertainty of measurement has been explicitly taken into account to declare the compliance or non-compliance to the specification. The report must not be used by the client to claim product certification, approval, or endorsement by TAF or any government agencies.

Table of Contents

Release Control Record	4
1 Certificate of Conformity	5
2 Summary of Test Results	6
2.1 Measurement Uncertainty	6
2.2 Modification Record	6
3 General Information	7
3.1 General Description of EUT	7
3.2 Description of Test Modes	8
3.2.1 Test Mode Applicability and Tested Channel Detail	9
3.3 Duty Cycle of Test Signal	11
3.4 Description of Support Units	12
3.4.1 Configuration of System under Test	12
3.5 General Description of Applied Standards	12
4 Test Types and Results	13
4.1 Radiated Emission and Bandedge Measurement	13
4.1.1 Limits of Radiated Emission and Bandedge Measurement	13
4.1.2 Test Instruments	14
4.1.3 Test Procedures	15
4.1.4 Deviation from Test Standard	16
4.1.5 Test Set Up	16
4.1.6 EUT Operating Conditions	17
4.1.7 Test Results	18
4.2 Conducted Emission Measurement	46
4.2.1 Limits of Conducted Emission Measurement	46
4.2.2 Test Instruments	46
4.2.3 Test Procedures	47
4.2.4 Deviation from Test Standard	47
4.2.5 Test Setup	47
4.2.6 EUT Operating Conditions	47
4.2.7 Test Results	48
4.3 6 dB Bandwidth Measurement	52
4.3.1 Limits of 6 dB Bandwidth Measurement	52
4.3.2 Test Setup	52
4.3.3 Test Instruments	52
4.3.4 Test Procedure	52
4.3.5 Deviation from Test Standard	52
4.3.6 EUT Operating Conditions	52
4.3.7 Test Results	53
4.4 Occupied Bandwidth Measurement	55
4.4.1 Test Setup	55
4.4.2 Test Instruments	55
4.4.3 Test Procedure	55
4.4.4 Deviation from Test Standard	55
4.4.5 EUT Operating Conditions	55
4.4.6 Test Results	56
4.5 Conducted Output Power Measurement	58
4.5.1 Limits of Conducted Output Power Measurement	58
4.5.2 Test Setup	58
4.5.3 Test Instruments	58
4.5.4 Test Procedures	58
4.5.5 Deviation from Test Standard	58
4.5.6 EUT Operating Conditions	58
4.5.7 Test Results	59

4.6	Power Spectral Density Measurement	60
4.6.1	Limits of Power Spectral Density Measurement.....	60
4.6.2	Test Setup.....	60
4.6.3	Test Instruments	60
4.6.4	Test Procedure	60
4.6.5	Deviation from Test Standard	60
4.6.6	EUT Operating Condition	60
4.6.7	Test Results	61
4.7	Conducted Out of Band Emission Measurement	63
4.7.1	Limits of Conducted Out of Band Emission Measurement.....	63
4.7.2	Test Setup.....	63
4.7.3	Test Instruments	63
4.7.4	Test Procedure	63
4.7.5	Deviation from Test Standard	63
4.7.6	EUT Operating Condition	63
4.7.7	Test Results	64
5	Pictures of Test Arrangements.....	68
	Appendix – Information of the Testing Laboratories	69

Release Control Record

Issue No.	Description	Date Issued
RF180918C26-2	Original Release	Oct. 18, 2019

1 Certificate of Conformity

Product: Wireless module

Brand: XPERI

Test Model: Caprica5

Sample Status: Engineering Sample

Applicant: Phorus, Inc.

Test Date: Jun. 18 ~ Oct. 03, 2019

Standards: 47 CFR FCC Part 15, Subpart C (Section 15.247)
ANSI C63.10:2013

The above equipment has been tested by **Bureau Veritas Consumer Products Services (H.K.) Ltd., Taoyuan Branch**, and found compliance with the requirement of the above standards. The test record, data evaluation & Equipment Under Test (EUT) configurations represented herein are true and accurate accounts of the measurements of the sample's RF characteristics under the conditions specified in this report.

Prepared by : Gina Liu, **Date:** Oct. 18, 2019
Gina Liu / Specialist

Approved by : Dylan Chiou, **Date:** Oct. 18, 2019
Dylan Chiou / Project Engineer

2 Summary of Test Results

47 CFR FCC Part 15, Subpart C (Section 15.247)			
FCC Clause	Test Item	Result	Remarks
15.207	AC Power Conducted Emission	Pass	Meet the requirement of limit. Minimum passing margin is -13.35 dB at 0.15391 MHz.
15.205 / 15.209 / 15.247(d)	Radiated Emissions and Band Edge Measurement	Pass	Meet the requirement of limit. Minimum passing margin is -5.37 dB at 750.1 MHz.
15.247(d)	Antenna Port Emission	Pass	Meet the requirement of limit.
15.247(a)(2)	6 dB Bandwidth	Pass	Meet the requirement of limit.
---	Occupied Bandwidth Measurement	Pass	Reference only
15.247(b)	Conducted power	Pass	Meet the requirement of limit.
15.247(e)	Power Spectral Density	Pass	Meet the requirement of limit.
15.203	Antenna Requirement	Pass	No antenna connector is used.

Note: Determining compliance based on the results of the compliance measurement, not taking into account measurement instrumentation uncertainty.

2.1 Measurement Uncertainty

Where relevant, the following measurement uncertainty levels have been estimated for tests performed on the EUT as specified in CISPR 16-4-2:

Measurement	Frequency	Expanded Uncertainty (k=2) (±)
Conducted Emissions at mains ports	150 kHz ~ 30 MHz	2.44 dB
Radiated Emissions up to 1 GHz	9 kHz ~ 30 MHz	3.04 dB
	30 MHz ~ 200 MHz	2.0153 dB
	200 MHz ~ 1000 MHz	2.0224 dB
Radiated Emissions above 1 GHz	1 GHz ~ 18 GHz	1.0121 dB
	18 GHz ~ 40 GHz	1.1508 dB

2.2 Modification Record

There were no modifications required for compliance.

3 General Information

3.1 General Description of EUT

Product	Wireless module
Brand	XPERI
Test Model	Caprica5
Status of EUT	Engineering Sample
Power Supply Rating	18 Vdc (adapter) 3.3 Vdc (Host equipment)
Modulation Type	CCK, DQPSK, DBPSK for DSSS 256QAM, 64QAM, 16QAM, QPSK, BPSK for OFDM
Modulation Technology	DSSS, OFDM
Transfer Rate	802.11b: 11.0 / 5.5 / 2.0 / 1.0 Mbps 802.11g: 54.0 / 48.0 / 36.0 / 24.0 / 18.0 / 12.0 / 9.0 / 6.0 Mbps 802.11n: up to 150 Mbps 802.11ac: up to 200 Mbps
Operating Frequency	2412 ~ 2462 MHz
Number of Channel	11 for 802.11b, 802.11g, 802.11n (HT20), 802.11ac (VHT20) 7 for 802.11n (HT40), 802.11ac (VHT40)
Output Power	392.645 mW
Antenna Type	PIFA antenna with 4.8 dBi gain / Dipole antenna with 5 dBi gain
Antenna Connector	IPEX Compatible
Accessory Device	Refer to Note as below
Data Cable Supplied	Refer to Note as below

Note:

- The EUT incorporates a SISO function. Physically, the EUT provides one completed transmitter and one receiver.

Modulation Mode	TX Function
802.11b	1TX (SISO)
802.11g	1TX (SISO)
802.11n (HT20)	1TX (SISO)
802.11n (HT40)	1TX (SISO)
802.11ac (VHT20)	1TX (SISO)
802.11ac (VHT40)	1TX (SISO)

* The modulation and bandwidth are similar for 802.11n mode for HT20 / HT40 and 802.11ac mode for VHT20 / VHT40, therefore investigated worst case to representative mode in test report. (Final test mode refer section 3.2.1)

- The EUT contains following accessory devices. (Not for sale together)

Product	Brand	Model	Description
Adapter	ADAPTER TECH.	ATS090T-P180	I/P: 100-240 Vac, 50-60 Hz, 1.2A MAX. O/P: 18Vdc, 5.0A, 90W MAX. 1.5m non-shielded cable with 1 core

- The above EUT information is declared by manufacturer and for more detailed features description, please refers to the manufacturer's specifications or user's manual.

3.2 Description of Test Modes

11 channels are provided for 802.11b, 802.11g, 802.11n (HT20) and 802.11ac (VHT20):

Channel	Frequency (MHz)	Channel	Frequency (MHz)
1	2412	7	2442
2	2417	8	2447
3	2422	9	2452
4	2427	10	2457
5	2432	11	2462
6	2437		

7 channels are provided for 802.11n (HT40) and 802.11ac (VHT40):

Channel	Frequency (MHz)	Channel	Frequency (MHz)
3	2422	7	2442
4	2427	8	2447
5	2432	9	2452
6	2437		

3.2.1 Test Mode Applicability and Tested Channel Detail

EUT Configure Mode	Applicable To				Description
	RE \geq 1G	RE<1G	PLC	APCM	
A	√	√	√	√	EUT with Dipole Antenna
B	√	√	√	-	EUT with PIFA Antenna

Where **RE \geq 1G**: Radiated Emission above 1 GHz **RE<1G**: Radiated Emission below 1 GHz
PLC: Power Line Conducted Emission **APCM**: Antenna Port Conducted Measurement

NOTE: The EUT had been pre-tested on the positioned of each 3 axis. The worst case was found when positioned on **X-plane**.
NOTE: "-" means no effect.

Radiated Emission Test (Above 1 GHz):

- Pre-Scan has been conducted to determine the worst-case mode from all possible combinations between available modulations, data rates and antenna ports (if EUT with antenna diversity architecture).
- Following channel(s) was (were) selected for the final test as listed below.

EUT Configure Mode	Mode	Available Channel	Tested Channel	Modulation Technology	Modulation Type	Data Rate (Mbps)
A, B	802.11b	1 to 11	1, 6, 11	DSSS	DBPSK	1.0
	802.11g	1 to 11	1, 6, 11	OFDM	BPSK	6.0
	802.11n (HT20)	1 to 11	1, 6, 11	OFDM	BPSK	6.5
	802.11n (HT40)	3 to 9	3, 6, 9	OFDM	BPSK	13.5

Radiated Emission Test (Below 1 GHz):

- Pre-Scan has been conducted to determine the worst-case mode from all possible combinations between available modulations, data rates and antenna ports (if EUT with antenna diversity architecture).
- Following channel(s) was (were) selected for the final test as listed below.

EUT Configure Mode	Mode	Available Channel	Tested Channel	Modulation Technology	Modulation Type	Data Rate (Mbps)
A	802.11g	1 to 11	1	OFDM	BPSK	6.0
B	802.11g	1 to 11	11	OFDM	BPSK	6.0

Power Line Conducted Emission Test:

- Pre-Scan has been conducted to determine the worst-case mode from all possible combinations between available modulations, data rates and antenna ports (if EUT with antenna diversity architecture).
- Following channel(s) was (were) selected for the final test as listed below.

EUT Configure Mode	Mode	Available Channel	Tested Channel	Modulation Technology	Modulation Type	Data Rate (Mbps)
A, B	802.11g	1 to 11	1	OFDM	BPSK	6.0

Bandedge Measurement:

- Pre-Scan has been conducted to determine the worst-case mode from all possible combinations between available modulations, data rates and antenna ports (if EUT with antenna diversity architecture).
- Following channel(s) was (were) selected for the final test as listed below.

EUT Configure Mode	Mode	Available Channel	Tested Channel	Modulation Technology	Modulation Type	Data Rate (Mbps)
-	802.11b	1 to 11	1, 11	DSSS	DBPSK	1.0
-	802.11g	1 to 11	1, 11	OFDM	BPSK	6.0
-	802.11n (HT20)	1 to 11	1, 11	OFDM	BPSK	6.5
-	802.11n (HT40)	3 to 9	3, 9	OFDM	BPSK	13.5

Antenna Port Conducted Measurement:

- This item includes all test value of each mode, but only includes spectrum plot of worst value of each mode.
- Pre-Scan has been conducted to determine the worst-case mode from all possible combinations between available modulations, data rates and antenna ports (if EUT with antenna diversity architecture).
- Following channel(s) was (were) selected for the final test as listed below.

EUT Configure Mode	Mode	Available Channel	Tested Channel	Modulation Technology	Modulation Type	Data Rate (Mbps)
-	802.11b	1 to 11	1, 6, 11	DSSS	DBPSK	1.0
-	802.11g	1 to 11	1, 6, 11	OFDM	BPSK	6.0
-	802.11n (HT20)	1 to 11	1, 6, 11	OFDM	BPSK	6.5
-	802.11n (HT40)	3 to 9	3, 6, 9	OFDM	BPSK	13.5

Test Condition:

Applicable To	Environmental Conditions	Input Power	Tested by
RE \geq 1G	25 deg. C, 65 % RH	120 Vac, 60 Hz	Charles Hsiao, Harry Hsueh, Karl Lee
RE<1G	25 deg. C, 65 % RH	120 Vac, 60 Hz	Karl Lee
PLC	25 deg. C, 65 % RH	120 Vac, 60 Hz	Thomas Wei
APCM	25 deg. C, 65 % RH	120 Vac, 60 Hz	Wayne Lin

3.3 Duty Cycle of Test Signal

802.11b: Duty cycle of test signal is $\geq 98\%$, duty factor is not required.

802.11g: Duty cycle = $2.063/2.342 = 0.881$, Duty factor = $10 * \log(1/0.881) = 0.55$

802.11n (HT20): Duty cycle = $1.919/2.042 = 0.940$, Duty factor = $10 * \log(1/0.940) = 0.27$

802.11n (HT40): Duty cycle = $0.942/1.261 = 0.747$, Duty factor = $10 * \log(1/0.747) = 1.27$

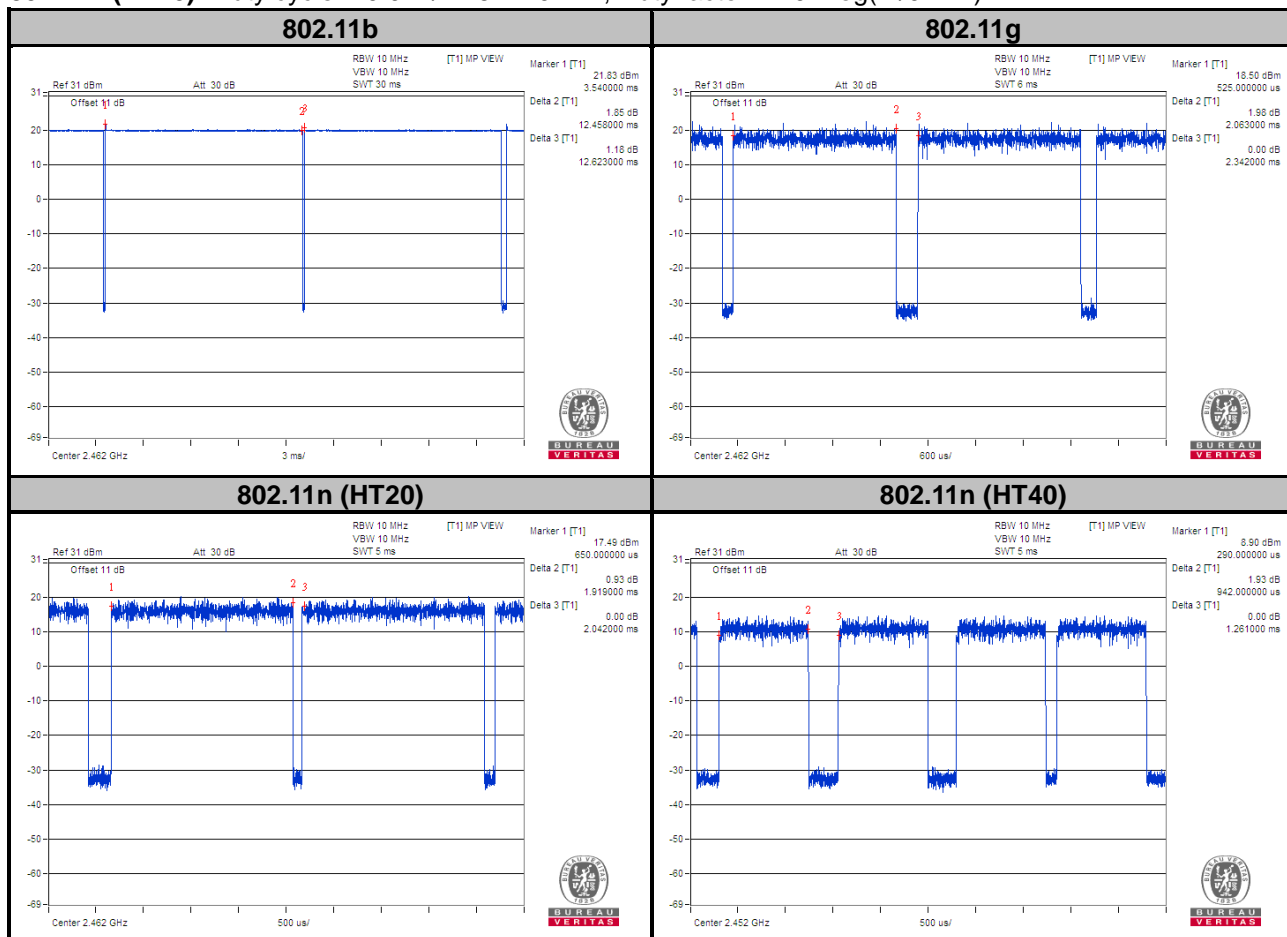

3.4 Description of Support Units

The EUT has been tested as an independent unit together with other necessary accessories or support units. The following support units or accessories were used to form a representative test configuration during the tests.

No.	Product	Brand	Model No.	Serial No.	FCC ID
1.	Notebook	DELL	E5410	1HC2XM1	N/A

Note:

1. All power cords of the above support units are non-shielded (1.8m).

3.4.1 Configuration of System under Test

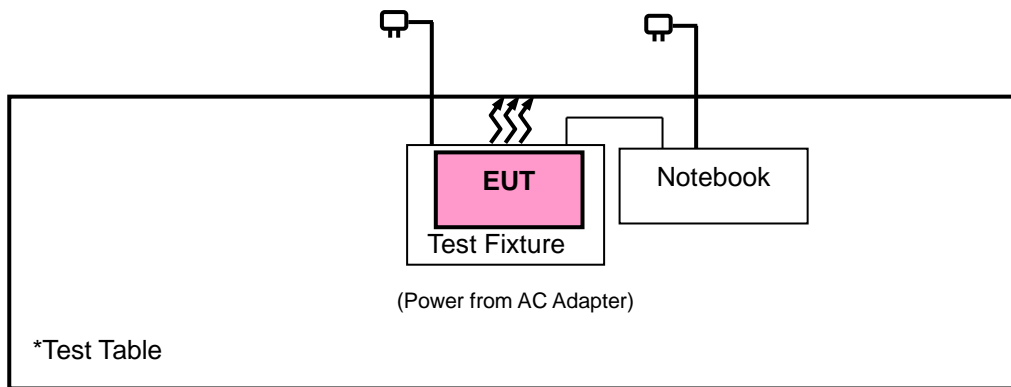

3.5 General Description of Applied Standards

The EUT is a RF Product. According to the specifications of the manufacturer, it must comply with the requirements of the following standards:

FCC Part 15, Subpart C (15.247)

KDB 558074 D01 15.247 Meas Guidance v05r02

ANSI C63.10-2013

All test items have been performed and recorded as per the above standards.

4 Test Types and Results

4.1 Radiated Emission and Bandedge Measurement

4.1.1 Limits of Radiated Emission and Bandedge Measurement

Radiated emissions which fall in the restricted bands must comply with the radiated emission limits specified as below table. Other emissions shall be at least 20 dB below the highest level of the desired power:

Frequencies (MHz)	Field Strength (microvolts/meter)	Measurement Distance (meters)
0.009 ~ 0.490	2400/F (kHz)	300
0.490 ~ 1.705	24000/F (kHz)	30
1.705 ~ 30.0	30	30
30 ~ 88	100	3
88 ~ 216	150	3
216 ~ 960	200	3
Above 960	500	3

NOTE:

1. The lower limit shall apply at the transition frequencies.
2. Emission level (dBuV/m) = 20 log Emission level (uV/m).
3. For frequencies above 1000 MHz, the field strength limits are based on average detector, however, the peak field strength of any emission shall not exceed the maximum permitted average limits, specified above by more than 20 dB under any condition of modulation.

4.1.2 Test Instruments

Description & Manufacturer	Model No.	Serial No.	Date of Calibration	Due Date of Calibration
Test Receiver Agilent Technologies	N9038A	MY52260177	Aug. 20, 2018	Aug. 19, 2019
Spectrum Analyzer ROHDE & SCHWARZ	FSP40	100040	Sep. 25, 2018	Sep. 24, 2019
BILOG Antenna SCHWARZBECK	VULB 9168	9168-616	Nov. 27, 2018	Nov. 26, 2019
HORN Antenna ETS-Lindgren	3117	00143293	Nov. 25, 2018	Nov. 24, 2019
HORN Antenna SCHWARZBECK	BBHA 9170	9170-480	Nov. 25, 2018	Nov. 24, 2019
Fixed Attenuator Mini-Circuits	MDCS18N-10	MDCS18N-10-01	Apr. 15, 2019	Apr. 14, 2020
Loop Antenna	EM-6879	269	Sep. 07, 2018	Sep. 06, 2019
Preamplifier Agilent	310N	187226	Jun. 18, 2019	Jun. 17, 2020
Preamplifier Agilent	83017A	MY39501357	Jun. 18, 2019	Jun. 17, 2020
Power Meter Anritsu	ML2495A	1012010	Sep. 05, 2018	Sep. 04, 2019
Power Sensor Anritsu	MA2411B	1315050	Sep. 04, 2018	Sep. 03, 2019
RF signal cable ETS-LINDGREN	5D-FB	Cable-CH1-01(RFC -SMS-100-SMS-12 0+RFC-SMS-100-S MS-400)	Jun. 18, 2019	Jun. 17, 2020
RF signal cable ETS-LINDGREN	8D-FB	Cable-CH1-02(RFC -SMS-100-SMS-24)	Jun. 18, 2019	Jun. 17, 2020
Software BV ADT	E3 8.130425b	NA	NA	NA
Antenna Tower MF	NA	NA	NA	NA
Turn Table MF	NA	NA	NA	NA
Antenna Tower & Turn Table Controller MF	MF-7802	NA	NA	NA

- Note: 1. The calibration interval of the above test instruments is 12 months and the calibrations are traceable to NML/ROC and NIST/USA.
2. The test was performed in HsinTien Chamber 1.

4.1.3 Test Procedures

For Radiated Emission below 30 MHz

- a. The EUT was placed on the top of a rotating table 0.8 meters above the ground at a 3 meter chamber room. The table was rotated 360 degrees to determine the position of the highest radiation.
- b. The EUT was set 3 meters away from the interference-receiving antenna, which was mounted on the top of a variable-height antenna tower.
- c. Parallel, perpendicular, and ground-parallel orientations of the antenna are set to make the measurement.
- d. For each suspected emission, the EUT was arranged to its worst case and the rotatable table was turned from 0 degrees to 360 degrees to find the maximum reading.
- e. The test-receiver system was set to Quasi-Peak Detect Function and Specified Bandwidth with Maximum Hold Mode.

Note:

1. The resolution bandwidth and video bandwidth of test receiver/spectrum analyzer is 9 kHz at frequency below 30 MHz.

For Radiated Emission above 30 MHz

- a. The EUT was placed on the top of a rotating table 0.8 meters (for 30 MHz ~ 1 GHz) / 1.5 meters (for above 1 GHz) above the ground at 3 meter chamber room for test. The table was rotated 360 degrees to determine the position of the highest radiation.
- b. The EUT was set 3 meters away from the interference-receiving antenna, which was mounted on the top of a variable-height antenna tower.
- c. The height of antenna is varied from one meter to four meters above the ground to determine the maximum value of the field strength. Both horizontal and vertical polarizations of the antenna are set to make the measurement.
- d. For each suspected emission, the EUT was arranged to its worst case and then the antenna was tuned to heights from 1 meter to 4 meters and the rotatable table was turned from 0 degrees to 360 degrees to find the maximum reading.
- e. The test-receiver system was set to quasi-peak detect function and specified bandwidth with maximum hold mode when the test frequency is below 1 GHz.
- f. The test-receiver system was set to peak and average detected function and specified bandwidth with maximum hold mode when the test frequency is above 1 GHz. If the peak reading value also meets average limit, measurement with the average detector is unnecessary.

Note:

1. The resolution bandwidth and video bandwidth of test receiver/spectrum analyzer is 120 kHz for Quasi-peak detection (QP) or Peak detection (PK) at frequency below 1 GHz.
2. The resolution bandwidth of test receiver/spectrum analyzer is 1 MHz and the video bandwidth is 3 MHz for Peak detection (PK) at frequency above 1 GHz.
3. The resolution bandwidth of test receiver/spectrum analyzer is 1 MHz and the video bandwidth is $\geq 1/T$ (Duty cycle < 98 %) or 10 Hz (Duty cycle ≥ 98 %) for Average detection (AV) at frequency above 1 GHz.
(11b: RBW = 1 MHz, VBW = 10 Hz ; 11g: RBW = 1 MHz, VBW = 1 kHz ;
11n (HT20): RBW = 1 MHz, VBW = 1 kHz ; 11n (HT40): RBW = 1 MHz, VBW = 0 kHz)
4. All modes of operation were investigated and the worst-case emissions are reported.

4.1.4 Deviation from Test Standard

No deviation.

4.1.5 Test Set Up

<Radiated Emission below 30 MHz>

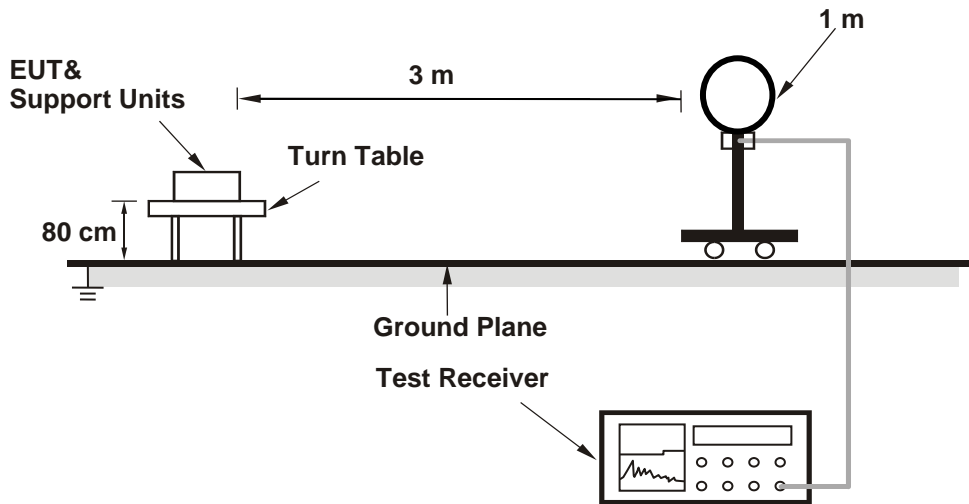

<Radiated Emission 30 MHz to 1 GHz>

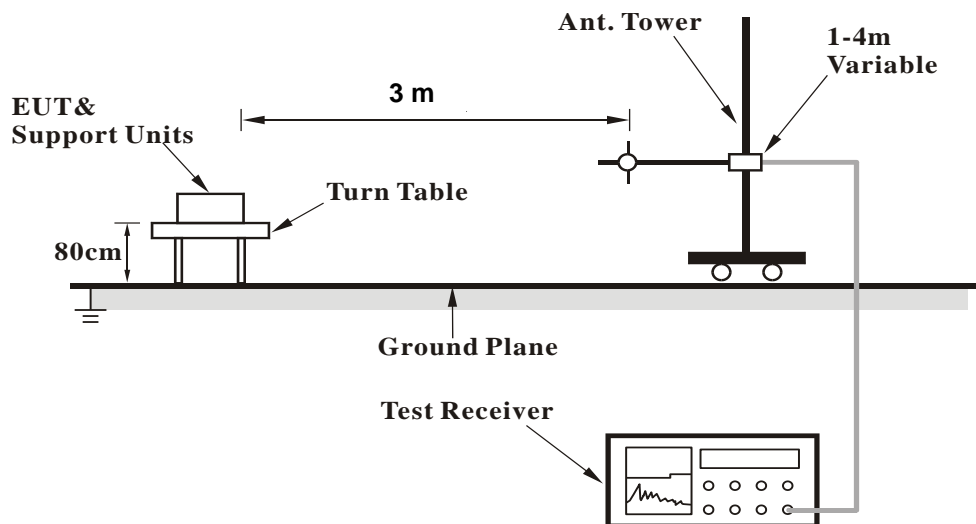

<Radiated Emission above 1 GHz>

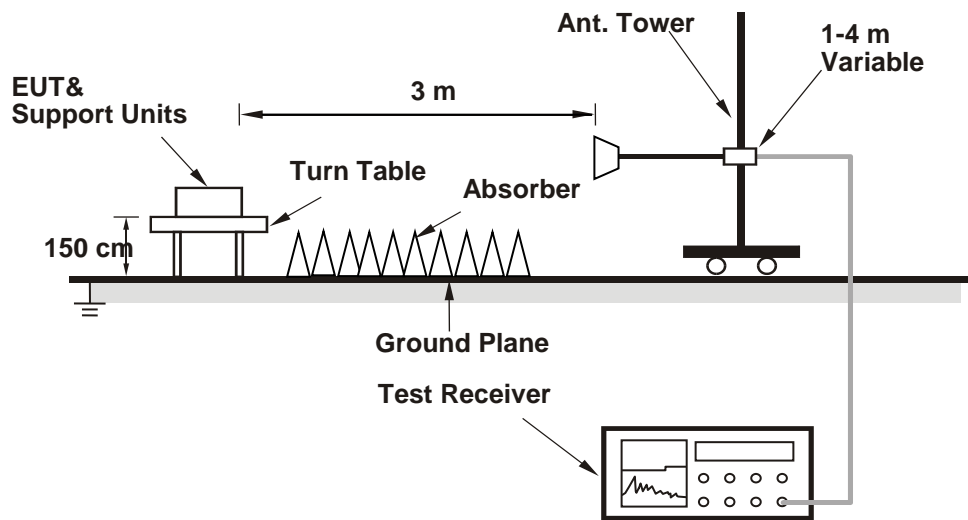

For the actual test configuration, please refer to the attached file (Test Setup Photo).

4.1.6 EUT Operating Conditions

- a. Placed the EUT on a testing table.
- b. Use the software to control the EUT under transmission condition continuously at specific channel frequency.

4.1.7 Test Results

Mode A

Above 1 GHz Data :

802.11b

EUT Test Condition		Measurement Detail	
Channel	Channel 1	Frequency Range	1 GHz ~ 25 GHz
Input Power	120 Vac, 60 Hz	Detector Function	Peak (PK) Average (AV)
Environmental Conditions	25 deg. C, 65 % RH	Tested By	Charles Hsiao

Antenna Polarity & Test Distance: Horizontal at 3 m								
Frequency (MHz)	Emission Level (dBuV/m)	Read Level (dBuV)	Factor (dB/m)	Limit (dBuV/m)	Margin (dB)	Antenna Height (cm)	Table Angle (Degree)	Remark
2386.59	43.48	41.77	1.71	54	-10.52	131	92	Average
2386.59	53.28	51.57	1.71	74	-20.72	131	92	Peak
2412	97.77	96	1.77			131	92	Average
2412	101.01	99.24	1.77			131	92	Peak
4824	37.91	29.78	8.13	54	-16.09	156	211	Average
4824	46.4	38.27	8.13	74	-27.6	156	211	Peak
Antenna Polarity & Test Distance: Vertical at 3 m								
Frequency (MHz)	Emission Level (dBuV/m)	Read Level (dBuV)	Factor (dB/m)	Limit (dBuV/m)	Margin (dB)	Antenna Height (cm)	Table Angle (Degree)	Remark
2386.23	52.27	50.56	1.71	54	-1.73	140	92	Average
2386.23	59.04	57.33	1.71	74	-14.96	140	92	Peak
2412	108.03	106.26	1.77			140	92	Average
2412	111.1	109.33	1.77			140	92	Peak
4824	38.16	30.03	8.13	54	-15.84	145	52	Average
4824	45.95	37.82	8.13	74	-28.05	145	52	Peak

Remarks:

- Emission Level = Read Level + Factor
Margin value = Emission level – Limit value
- 2412 MHz: Fundamental frequency.
- The emission levels of other frequencies were very low against the limit.

EUT Test Condition		Measurement Detail	
Channel	Channel 6	Frequency Range	1 GHz ~ 25 GHz
Input Power	120 Vac, 60 Hz	Detector Function	Peak (PK) Average (AV)
Environmental Conditions	25 deg. C, 65 % RH	Tested By	Charles Hsiao

Antenna Polarity & Test Distance: Horizontal at 3 m								
Frequency (MHz)	Emission Level (dBuV/m)	Read Level (dBuV)	Factor (dB/m)	Limit (dBuV/m)	Margin (dB)	Antenna Height (cm)	Table Angle (Degree)	Remark
2389.65	42.85	41.14	1.71	54	-11.15	144	43	Average
2389.65	52.55	50.84	1.71	74	-21.45	144	43	Peak
2437	102.88	101.03	1.85			144	43	Average
2437	106.57	104.72	1.85			144	43	Peak
2484.56	43.71	41.72	1.99	54	-10.29	144	43	Average
2484.56	53.46	51.47	1.99	74	-20.54	144	43	Peak
4874	47.41	39.22	8.19	54	-6.59	118	106	Average
4874	50.37	42.18	8.19	74	-23.63	118	106	Peak

Antenna Polarity & Test Distance: Vertical at 3 m								
Frequency (MHz)	Emission Level (dBuV/m)	Read Level (dBuV)	Factor (dB/m)	Limit (dBuV/m)	Margin (dB)	Antenna Height (cm)	Table Angle (Degree)	Remark
2389.47	50.85	49.14	1.71	54	-3.15	140	92	Average
2389.47	57.73	56.02	1.71	74	-16.27	140	92	Peak
2437	112.86	75.55	37.31			140	92	Average
2437	115.56	78.25	37.31			140	92	Peak
2484.84	52.91	50.92	1.99	54	-1.09	140	92	Average
2484.84	58.99	57	1.99	74	-15.01	140	92	Peak
4874	52.88	44.69	8.19	54	-1.12	206	203	Average
4874	55.96	47.77	8.19	74	-18.04	206	203	Peak

Remarks:

- Emission Level = Read Level + Factor
Margin value = Emission level – Limit value
- 2437 MHz: Fundamental frequency.
- The emission levels of other frequencies were very low against the limit.

EUT Test Condition		Measurement Detail	
Channel	Channel 11	Frequency Range	1 GHz ~ 25 GHz
Input Power	120 Vac, 60 Hz	Detector Function	Peak (PK) Average (AV)
Environmental Conditions	25 deg. C, 65 % RH	Tested By	Charles Hsiao

Antenna Polarity & Test Distance: Horizontal at 3 m								
Frequency (MHz)	Emission Level (dBuV/m)	Read Level (dBuV)	Factor (dB/m)	Limit (dBuV/m)	Margin (dB)	Antenna Height (cm)	Table Angle (Degree)	Remark
2462	97.54	95.61	1.93			144	43	Average
2462	100.32	98.39	1.93			144	43	Peak
2487.52	43.03	41.02	2.01	54	-10.97	144	43	Average
2487.52	53.23	51.22	2.01	74	-20.77	144	43	Peak
4924	37.24	28.99	8.25	54	-16.76	145	52	Average
4924	45.72	37.47	8.25	74	-28.28	145	52	Peak
Antenna Polarity & Test Distance: Vertical at 3 m								
Frequency (MHz)	Emission Level (dBuV/m)	Read Level (dBuV)	Factor (dB/m)	Limit (dBuV/m)	Margin (dB)	Antenna Height (cm)	Table Angle (Degree)	Remark
2462	106.88	69.51	37.37			140	92	Average
2462	109.07	71.7	37.37			140	92	Peak
2487.76	52.84	50.83	2.01	54	-1.16	140	92	Average
2487.76	59.6	57.59	2.01	74	-14.4	140	92	Peak
4924	37.8	29.55	8.25	54	-16.2	133	254	Average
4924	45.92	37.67	8.25	74	-28.08	133	254	Peak

Remarks:

- Emission Level = Read Level + Factor
Margin value = Emission level – Limit value
- 2462 MHz: Fundamental frequency.
- The emission levels of other frequencies were very low against the limit.

802.11g

EUT Test Condition		Measurement Detail	
Channel	Channel 1	Frequency Range	1 GHz ~ 25 GHz
Input Power	120 Vac, 60 Hz	Detector Function	Peak (PK) Average (AV)
Environmental Conditions	25 deg. C, 65 % RH	Tested By	Charles Hsiao

Antenna Polarity & Test Distance: Horizontal at 3 m								
Frequency (MHz)	Emission Level (dBuV/m)	Read Level (dBuV)	Factor (dB/m)	Limit (dBuV/m)	Margin (dB)	Antenna Height (cm)	Table Angle (Degree)	Remark
2389.92	44.15	42.42	1.73	54	-9.85	131	92	Average
2389.92	57.18	55.45	1.73	74	-16.82	131	92	Peak
2412	93.58	91.81	1.77			131	92	Average
2412	102.07	100.3	1.77			131	92	Peak
4824	38.38	30.25	8.13	54	-15.62	159	99	Average
4824	46.55	38.42	8.13	74	-27.45	159	99	Peak
Antenna Polarity & Test Distance: Vertical at 3 m								
Frequency (MHz)	Emission Level (dBuV/m)	Read Level (dBuV)	Factor (dB/m)	Limit (dBuV/m)	Margin (dB)	Antenna Height (cm)	Table Angle (Degree)	Remark
2389.92	52.99	51.26	1.73	54	-1.01	140	92	Average
2389.92	69.41	67.68	1.73	74	-4.59	140	92	Peak
2412	103.82	66.58	37.24			140	92	Average
2412	112.5	75.26	37.24			140	92	Peak
4824	38.38	30.25	8.13	54	-15.62	133	285	Average
4824	46.25	38.12	8.13	74	-27.75	133	285	Peak

Remarks:

- Emission Level = Read Level + Factor
Margin value = Emission level – Limit value
- 2412 MHz: Fundamental frequency.
- The emission levels of other frequencies were very low against the limit.

EUT Test Condition		Measurement Detail	
Channel	Channel 6	Frequency Range	1 GHz ~ 25 GHz
Input Power	120 Vac, 60 Hz	Detector Function	Peak (PK) Average (AV)
Environmental Conditions	25 deg. C, 65 % RH	Tested By	Charles Hsiao

Antenna Polarity & Test Distance: Horizontal at 3 m								
Frequency (MHz)	Emission Level (dBuV/m)	Read Level (dBuV)	Factor (dB/m)	Limit (dBuV/m)	Margin (dB)	Antenna Height (cm)	Table Angle (Degree)	Remark
2389.65	42.61	40.9	1.71	54	-11.39	144	43	Average
2389.65	54.64	52.93	1.71	74	-19.36	144	43	Peak
2437	98.21	96.36	1.85			144	43	Average
2437	106.94	105.09	1.85			144	43	Peak
2484.56	42.19	40.2	1.99	54	-11.81	144	43	Average
2484.56	55.42	53.43	1.99	74	-18.58	144	43	Peak
4874	38.19	30	8.19	54	-15.81	118	106	Average
4874	47.71	39.52	8.19	74	-26.29	118	106	Peak

Antenna Polarity & Test Distance: Vertical at 3 m								
Frequency (MHz)	Emission Level (dBuV/m)	Read Level (dBuV)	Factor (dB/m)	Limit (dBuV/m)	Margin (dB)	Antenna Height (cm)	Table Angle (Degree)	Remark
2389.92	49.82	48.09	1.73	54	-4.18	140	92	Average
2389.92	63.08	61.35	1.73	74	-10.92	140	92	Peak
2437	108.56	106.71	1.85			140	92	Average
2437	117.15	115.3	1.85			140	92	Peak
2483.76	49.18	47.22	1.96	54	-4.82	140	92	Average
2483.76	65.04	63.08	1.96	74	-8.96	140	92	Peak
4874	43.03	34.84	8.19	54	-10.97	198	202	Average
4874	51.02	42.83	8.19	74	-22.98	198	202	Peak

Remarks:

- Emission Level = Read Level + Factor
Margin value = Emission level – Limit value
- 2437 MHz: Fundamental frequency.
- The emission levels of other frequencies were very low against the limit.

EUT Test Condition		Measurement Detail	
Channel	Channel 11	Frequency Range	1 GHz ~ 25 GHz
Input Power	120 Vac, 60 Hz	Detector Function	Peak (PK) Average (AV)
Environmental Conditions	25 deg. C, 65 % RH	Tested By	Charles Hsiao

Antenna Polarity & Test Distance: Horizontal at 3 m								
Frequency (MHz)	Emission Level (dBuV/m)	Read Level (dBuV)	Factor (dB/m)	Limit (dBuV/m)	Margin (dB)	Antenna Height (cm)	Table Angle (Degree)	Remark
2462	93.59	91.66	1.93			144	43	Average
2462	100.48	98.55	1.93			144	43	Peak
2483.6	43.81	41.85	1.96	54	-10.19	144	43	Average
2483.6	59.97	58.01	1.96	74	-14.03	144	43	Peak
4924	38.87	30.62	8.25	54	-15.13	185	197	Average
4924	45.72	37.47	8.25	74	-28.28	185	197	Peak
Antenna Polarity & Test Distance: Vertical at 3 m								
Frequency (MHz)	Emission Level (dBuV/m)	Read Level (dBuV)	Factor (dB/m)	Limit (dBuV/m)	Margin (dB)	Antenna Height (cm)	Table Angle (Degree)	Remark
2462	102.58	100.65	1.93			140	92	Average
2462	109.75	107.82	1.93			140	92	Peak
2483.52	52.89	50.93	1.96	54	-1.11	140	92	Average
2483.52	71.29	69.33	1.96	74	-2.71	140	92	Peak
4924	38.53	30.28	8.25	54	-15.47	152	56	Average
4924	46.11	37.86	8.25	74	-27.89	152	56	Peak

Remarks:

- Emission Level = Read Level + Factor
Margin value = Emission level – Limit value
- 2462 MHz: Fundamental frequency.
- The emission levels of other frequencies were very low against the limit.

802.11n (HT20)

EUT Test Condition		Measurement Detail	
Channel	Channel 1	Frequency Range	1 GHz ~ 25 GHz
Input Power	120 Vac, 60 Hz	Detector Function	Peak (PK) Average (AV)
Environmental Conditions	25 deg. C, 65 % RH	Tested By	Charles Hsiao

Antenna Polarity & Test Distance: Horizontal at 3 m

Frequency (MHz)	Emission Level (dBuV/m)	Read Level (dBuV)	Factor (dB/m)	Limit (dBuV/m)	Margin (dB)	Antenna Height (cm)	Table Angle (Degree)	Remark
2389.92	43.4	41.67	1.73	54	-10.6	131	92	Average
2389.92	56.25	54.52	1.73	74	-17.75	131	92	Peak
2412	92.3	90.53	1.77			131	92	Average
2412	100.79	99.02	1.77			131	92	Peak
4824	38.55	30.42	8.13	54	-15.45	185	87	Average
4824	45.88	37.75	8.13	74	-28.12	185	87	Peak

Antenna Polarity & Test Distance: Vertical at 3 m

Frequency (MHz)	Emission Level (dBuV/m)	Read Level (dBuV)	Factor (dB/m)	Limit (dBuV/m)	Margin (dB)	Antenna Height (cm)	Table Angle (Degree)	Remark
2389.92	52.46	50.73	1.73	54	-1.54	140	92	Average
2389.92	66.35	64.62	1.73	74	-7.65	140	92	Peak
2412	102.61	100.84	1.77			140	92	Average
2412	111.44	109.67	1.77			140	92	Peak
4824	38.38	30.25	8.13	54	-15.62	133	325	Average
4824	45.98	37.85	8.13	74	-28.02	133	325	Peak

Remarks:

- Emission Level = Read Level + Factor
Margin value = Emission level – Limit value
- 2412 MHz: Fundamental frequency.
- The emission levels of other frequencies were very low against the limit.

EUT Test Condition		Measurement Detail	
Channel	Channel 6	Frequency Range	1 GHz ~ 25 GHz
Input Power	120 Vac, 60 Hz	Detector Function	Peak (PK) Average (AV)
Environmental Conditions	25 deg. C, 65 % RH	Tested By	Charles Hsiao

Antenna Polarity & Test Distance: Horizontal at 3 m								
Frequency (MHz)	Emission Level (dBuV/m)	Read Level (dBuV)	Factor (dB/m)	Limit (dBuV/m)	Margin (dB)	Antenna Height (cm)	Table Angle (Degree)	Remark
2389.74	43.32	41.61	1.71	54	-10.68	144	43	Average
2389.74	56.17	54.46	1.71	74	-17.83	144	43	Peak
2437	97.76	95.91	1.85			144	43	Average
2437	106.52	104.67	1.85			144	43	Peak
2483.68	42.7	40.74	1.96	54	-11.3	144	43	Average
2483.68	56.2	54.24	1.96	74	-17.8	144	43	Peak
4874	38.96	30.77	8.19	54	-15.04	113	106	Average
4874	46.78	38.59	8.19	74	-27.22	113	106	Peak

Antenna Polarity & Test Distance: Vertical at 3 m								
Frequency (MHz)	Emission Level (dBuV/m)	Read Level (dBuV)	Factor (dB/m)	Limit (dBuV/m)	Margin (dB)	Antenna Height (cm)	Table Angle (Degree)	Remark
2389.92	50.09	48.36	1.73	54	-3.91	140	92	Average
2389.92	64.49	62.76	1.73	74	-9.51	140	92	Peak
2437	108.41	106.56	1.85			140	92	Average
2437	117.02	115.17	1.85			140	92	Peak
2483.96	51.13	49.17	1.96	54	-2.87	140	92	Average
2483.96	70.86	68.9	1.96	74	-3.14	140	92	Peak
4874	42.77	34.58	8.19	54	-11.23	198	202	Average
4874	50.95	42.76	8.19	74	-23.05	198	202	Peak

Remarks:

- Emission Level = Read Level + Factor
Margin value = Emission level – Limit value
- 2437 MHz: Fundamental frequency.
- The emission levels of other frequencies were very low against the limit.

EUT Test Condition		Measurement Detail	
Channel	Channel 11	Frequency Range	1 GHz ~ 25 GHz
Input Power	120 Vac, 60 Hz	Detector Function	Peak (PK) Average (AV)
Environmental Conditions	25 deg. C, 65 % RH	Tested By	Charles Hsiao

Antenna Polarity & Test Distance: Horizontal at 3 m								
Frequency (MHz)	Emission Level (dBuV/m)	Read Level (dBuV)	Factor (dB/m)	Limit (dBuV/m)	Margin (dB)	Antenna Height (cm)	Table Angle (Degree)	Remark
2462	91.36	89.43	1.93			144	43	Average
2462	98.04	96.11	1.93			144	43	Peak
2483.52	43.38	41.42	1.96	54	-10.62	144	43	Average
2483.52	57.37	55.41	1.96	74	-16.63	144	43	Peak
4924	38.25	30	8.25	54	-15.75	132	75	Average
4924	45.89	37.64	8.25	74	-28.11	132	75	Peak
Antenna Polarity & Test Distance: Vertical at 3 m								
Frequency (MHz)	Emission Level (dBuV/m)	Read Level (dBuV)	Factor (dB/m)	Limit (dBuV/m)	Margin (dB)	Antenna Height (cm)	Table Angle (Degree)	Remark
2462	101.47	99.54	1.93			140	92	Average
2462	108.23	106.3	1.93			140	92	Peak
2483.56	52.79	50.83	1.96	54	-1.21	140	92	Average
2483.56	68.58	66.62	1.96	74	-5.42	140	92	Peak
4924	39.02	30.77	8.25	54	-14.98	132	225	Average
4924	46.32	38.07	8.25	74	-27.68	132	225	Peak

Remarks:

- Emission Level = Read Level + Factor
Margin value = Emission level – Limit value
- 2462 MHz: Fundamental frequency.
- The emission levels of other frequencies were very low against the limit.

802.11n (HT40)

EUT Test Condition		Measurement Detail	
Channel	Channel 3	Frequency Range	1 GHz ~ 25 GHz
Input Power	120 Vac, 60 Hz	Detector Function	Peak (PK) Average (AV)
Environmental Conditions	25 deg. C, 65 % RH	Tested By	Charles Hsiao

Antenna Polarity & Test Distance: Horizontal at 3 m								
Frequency (MHz)	Emission Level (dBuV/m)	Read Level (dBuV)	Factor (dB/m)	Limit (dBuV/m)	Margin (dB)	Antenna Height (cm)	Table Angle (Degree)	Remark
2386.14	43.85	42.14	1.71	54	-10.15	131	92	Average
2386.14	57.15	55.44	1.71	74	-16.85	131	92	Peak
2422	88.79	86.99	1.8			131	92	Average
2422	96.05	94.25	1.8			131	92	Peak
2484.36	41.06	39.07	1.99	54	-12.94	131	92	Average
2484.36	52.12	50.13	1.99	74	-21.88	131	92	Peak
4844	38.74	30.59	8.15	54	-15.26	185	178	Average
4844	46.02	37.87	8.15	74	-27.98	185	178	Peak
Antenna Polarity & Test Distance: Vertical at 3 m								
Frequency (MHz)	Emission Level (dBuV/m)	Read Level (dBuV)	Factor (dB/m)	Limit (dBuV/m)	Margin (dB)	Antenna Height (cm)	Table Angle (Degree)	Remark
2389.56	52.96	51.25	1.71	54	-1.04	131	92	Average
2389.56	67.99	66.28	1.71	74	-6.01	131	92	Peak
2422	98.5	96.7	1.8			131	92	Average
2422	106.51	104.71	1.8			131	92	Peak
2484.28	44	42.01	1.99	54	-10	131	92	Average
2484.28	56.02	54.03	1.99	74	-17.98	131	92	Peak
4844	38.56	30.41	8.15	54	-15.44	189	197	Average
4844	45.37	37.22	8.15	74	-28.63	189	197	Peak

Remarks:

- Emission Level = Read Level + Factor
Margin value = Emission level – Limit value
- 2422 MHz: Fundamental frequency.
- The emission levels of other frequencies were very low against the limit.

EUT Test Condition		Measurement Detail	
Channel	Channel 6	Frequency Range	1 GHz ~ 25 GHz
Input Power	120 Vac, 60 Hz	Detector Function	Peak (PK) Average (AV)
Environmental Conditions	25 deg. C, 65 % RH	Tested By	Charles Hsiao

Antenna Polarity & Test Distance: Horizontal at 3 m								
Frequency (MHz)	Emission Level (dBuV/m)	Read Level (dBuV)	Factor (dB/m)	Limit (dBuV/m)	Margin (dB)	Antenna Height (cm)	Table Angle (Degree)	Remark
2389.83	45.4	43.67	1.73	54	-8.6	144	43	Average
2389.83	57.94	56.21	1.73	74	-16.06	144	43	Peak
2437	90.54	88.69	1.85			144	43	Average
2437	97.74	95.89	1.85			144	43	Peak
2483.68	45.03	43.07	1.96	54	-8.97	144	43	Average
2483.68	58.47	56.51	1.96	74	-15.53	144	43	Peak
4874	38.36	30.17	8.19	54	-15.64	187	145	Average
4874	45.87	37.68	8.19	74	-28.13	187	145	Peak

Antenna Polarity & Test Distance: Vertical at 3 m								
Frequency (MHz)	Emission Level (dBuV/m)	Read Level (dBuV)	Factor (dB/m)	Limit (dBuV/m)	Margin (dB)	Antenna Height (cm)	Table Angle (Degree)	Remark
2389.92	51.27	49.54	1.73	54	-2.73	144	43	Average
2389.92	64.9	63.17	1.73	74	-9.1	144	43	Peak
2437	99.58	97.73	1.85			144	43	Average
2437	106.49	104.64	1.85			144	43	Peak
2483.52	52.89	50.93	1.96	54	-1.11	144	43	Average
2483.52	67.95	65.99	1.96	74	-6.05	144	43	Peak
4874	39.99	31.8	8.19	54	-14.01	195	200	Average
4874	46.55	38.36	8.19	74	-27.45	195	200	Peak

Remarks:

- Emission Level = Read Level + Factor
Margin value = Emission level – Limit value
- 2437 MHz: Fundamental frequency.
- The emission levels of other frequencies were very low against the limit.

EUT Test Condition		Measurement Detail	
Channel	Channel 9	Frequency Range	1 GHz ~ 25 GHz
Input Power	120 Vac, 60 Hz	Detector Function	Peak (PK) Average (AV)
Environmental Conditions	25 deg. C, 65 % RH	Tested By	Charles Hsiao

Antenna Polarity & Test Distance: Horizontal at 3 m								
Frequency (MHz)	Emission Level (dBuV/m)	Read Level (dBuV)	Factor (dB/m)	Limit (dBuV/m)	Margin (dB)	Antenna Height (cm)	Table Angle (Degree)	Remark
2388.57	41.51	39.8	1.71	54	-12.49	144	43	Average
2388.57	52.04	50.33	1.71	74	-21.96	144	43	Peak
2452	88.58	86.71	1.87			144	43	Average
2452	95.3	93.43	1.87			144	43	Peak
2483.76	43.61	41.65	1.96	54	-10.39	144	43	Average
2483.76	54.4	52.44	1.96	74	-19.6	144	43	Peak
4904	39.8	31.58	8.22	54	-14.2	135	264	Average
4904	46.68	38.46	8.22	74	-27.32	135	264	Peak

Antenna Polarity & Test Distance: Vertical at 3 m								
Frequency (MHz)	Emission Level (dBuV/m)	Read Level (dBuV)	Factor (dB/m)	Limit (dBuV/m)	Margin (dB)	Antenna Height (cm)	Table Angle (Degree)	Remark
2334.57	43.79	42.24	1.55	54	-10.21	140	92	Average
2334.57	54.68	53.13	1.55	74	-19.32	140	92	Peak
2452	97.49	95.62	1.87			140	92	Average
2452	104.46	102.59	1.87			140	92	Peak
2483.52	52.7	50.74	1.96	54	-1.3	140	92	Average
2483.52	64.41	62.45	1.96	74	-9.59	140	92	Peak
4904	39.22	31	8.22	54	-14.78	190	198	Average
4904	46.19	37.97	8.22	74	-27.81	190	198	Peak

Remarks:

- Emission Level = Read Level + Factor
Margin value = Emission level – Limit value
- 2452 MHz: Fundamental frequency.
- The emission levels of other frequencies were very low against the limit.

9 kHz ~ 30 MHz Data:

The amplitude of spurious emissions attenuated more than 20 dB below the permissible value is not required to be report.

30 MHz ~ 1 GHz Worst-Case Data:

802.11g

EUT Test Condition		Measurement Detail	
Channel	Channel 1	Frequency Range	30 MHz ~ 1 GHz
Input Power	120 Vac, 60 Hz	Detector Function	Peak (PK) Quasi-peak (QP)
Environmental Conditions	25 deg. C, 65 % RH	Tested By	Karl Lee

Horizontal

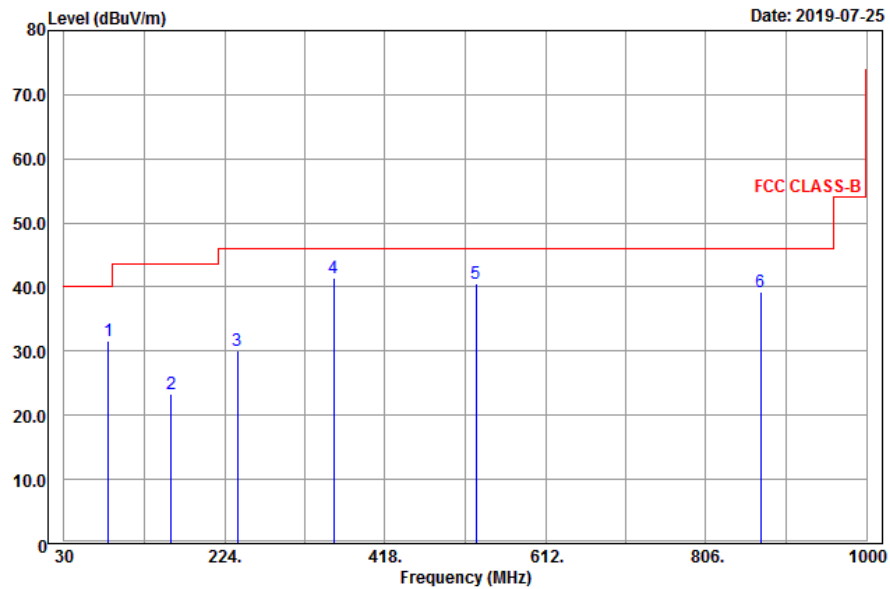

Vertical

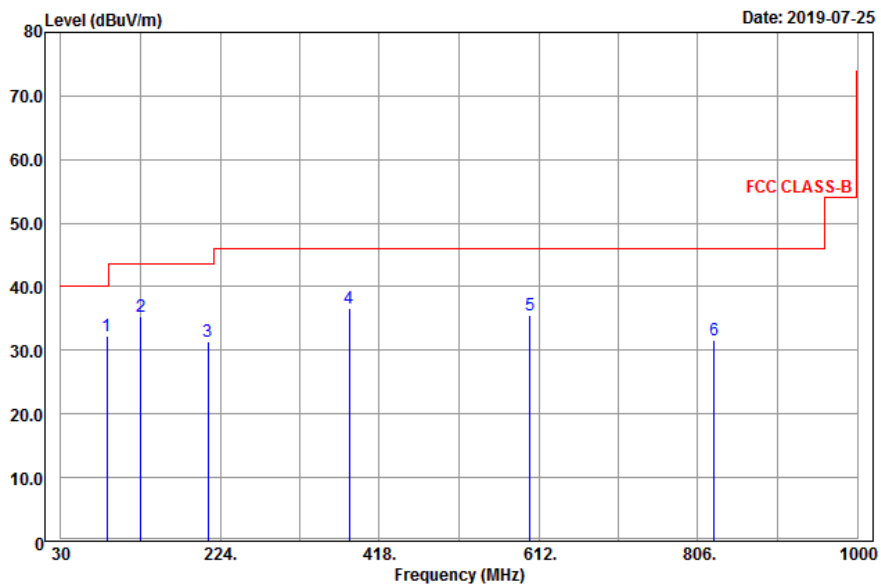

Antenna Polarity & Test Distance: Horizontal at 3 m								
Frequency (MHz)	Emission Level (dBuV/m)	Read Level (dBuV)	Factor (dB/m)	Limit (dBuV/m)	Margin (dB)	Antenna Height (cm)	Table Angle (Degree)	Remark
83.73	31.71	52.46	-20.75	40	-8.29	172	257	Peak
159.6	23.37	43.96	-20.59	43.5	-20.13	108	159	Peak
239.79	30.13	47.18	-17.05	46	-15.87	136	226	Peak
356	41.38	56.02	-14.64	46	-4.62	186	219	Peak
528.2	40.64	52.54	-11.9	46	-5.36	174	106	Peak
872.6	39.18	45.48	-6.3	46	-6.82	105	23	Peak
Antenna Polarity & Test Distance: Vertical at 3 m								
Frequency (MHz)	Emission Level (dBuV/m)	Read Level (dBuV)	Factor (dB/m)	Limit (dBuV/m)	Margin (dB)	Antenna Height (cm)	Table Angle (Degree)	Remark
85.89	32.26	52.35	-20.09	40	-7.74	133	106	Peak
127.47	35.42	55.61	-20.19	43.5	-8.08	196	287	Peak
209.01	31.44	49.59	-18.15	43.5	-12.06	190	214	Peak
381.2	36.64	50.86	-14.22	46	-9.36	175	24	Peak
601.7	35.43	45.97	-10.54	46	-10.57	132	68	Peak
825.7	31.65	38.88	-7.23	46	-14.35	187	151	Peak

Remarks:

- Emission Level = Read Level + Factor
Margin value = Emission level – Limit value.
- The emission levels of other frequencies were very low against the limit.

Mode B

Above 1 GHz Data :

802.11b

EUT Test Condition		Measurement Detail	
Channel	Channel 1	Frequency Range	1 GHz ~ 25 GHz
Input Power	120 Vac, 60 Hz	Detector Function	Peak (PK) Average (AV)
Environmental Conditions	25 deg. C, 65 % RH	Tested By	Karl Lee

Antenna Polarity & Test Distance: Horizontal at 3 m								
Frequency (MHz)	Emission Level (dBuV/m)	Read Level (dBuV)	Factor (dB/m)	Limit (dBuV/m)	Margin (dB)	Antenna Height (cm)	Table Angle (Degree)	Remark
2387.31	44.75	40.26	4.49	54	-9.25	129	261	Average
2387.31	53.92	49.43	4.49	74	-20.08	129	261	Peak
2412	100.12	95.57	4.55			129	261	Average
2412	103	98.45	4.55			129	261	Peak
4824	52.87	42.58	10.29	54	-1.13	237	81	Average
4824	56.67	46.38	10.29	74	-17.33	237	81	Peak
Antenna Polarity & Test Distance: Vertical at 3 m								
Frequency (MHz)	Emission Level (dBuV/m)	Read Level (dBuV)	Factor (dB/m)	Limit (dBuV/m)	Margin (dB)	Antenna Height (cm)	Table Angle (Degree)	Remark
2385.96	41.89	37.4	4.49	54	-12.11	262	358	Average
2385.96	52.46	47.97	4.49	74	-21.54	262	358	Peak
2412	95.05	90.5	4.55			262	358	Average
2412	98.75	94.2	4.55			262	358	Peak
4824	47.82	37.53	10.29	54	-6.18	310	43	Average
4824	53.66	43.37	10.29	74	-20.34	310	43	Peak

Remarks:

- Emission Level = Read Level + Factor
Margin value = Emission level – Limit value
- 2412 MHz: Fundamental frequency.
- The emission levels of other frequencies were very low against the limit.

EUT Test Condition		Measurement Detail	
Channel	Channel 6	Frequency Range	1 GHz ~ 25 GHz
Input Power	120 Vac, 60 Hz	Detector Function	Peak (PK) Average (AV)
Environmental Conditions	25 deg. C, 65 % RH	Tested By	Harry Hsueh

Antenna Polarity & Test Distance: Horizontal at 3 m								
Frequency (MHz)	Emission Level (dBuV/m)	Read Level (dBuV)	Factor (dB/m)	Limit (dBuV/m)	Margin (dB)	Antenna Height (cm)	Table Angle (Degree)	Remark
2388.57	41.22	36.73	4.49	54	-12.78	274	215	Average
2388.57	52.06	47.57	4.49	74	-21.94	274	215	Peak
2437	100.47	95.88	4.59			274	215	Average
2437	104.25	99.66	4.59			274	215	Peak
2485.32	41.44	36.78	4.66	54	-12.56	274	215	Average
2485.32	52.42	47.76	4.66	74	-21.58	274	215	Peak
4874	52.35	42.14	10.21	54	-1.65	238	85	Average
4874	55.73	45.52	10.21	74	-18.27	238	85	Peak

Antenna Polarity & Test Distance: Vertical at 3 m								
Frequency (MHz)	Emission Level (dBuV/m)	Read Level (dBuV)	Factor (dB/m)	Limit (dBuV/m)	Margin (dB)	Antenna Height (cm)	Table Angle (Degree)	Remark
2385.42	40.9	36.43	4.47	54	-13.1	280	358	Average
2385.42	51.93	47.46	4.47	74	-22.07	280	358	Peak
2437	95.28	90.69	4.59			280	358	Average
2437	98.47	93.88	4.59			280	358	Peak
2487.36	41	36.34	4.66	54	-13	280	358	Average
2487.36	51.88	47.22	4.66	74	-22.12	280	358	Peak
4874	48.21	38	10.21	54	-5.79	283	43	Average
4874	51.77	41.56	10.21	74	-22.23	283	43	Peak

Remarks:

- Emission Level = Read Level + Factor
Margin value = Emission level – Limit value
- 2437 MHz: Fundamental frequency.
- The emission levels of other frequencies were very low against the limit.

EUT Test Condition		Measurement Detail	
Channel	Channel 11	Frequency Range	1 GHz ~ 25 GHz
Input Power	120 Vac, 60 Hz	Detector Function	Peak (PK) Average (AV)
Environmental Conditions	25 deg. C, 65 % RH	Tested By	Harry Hsueh

Antenna Polarity & Test Distance: Horizontal at 3 m								
Frequency (MHz)	Emission Level (dBuV/m)	Read Level (dBuV)	Factor (dB/m)	Limit (dBuV/m)	Margin (dB)	Antenna Height (cm)	Table Angle (Degree)	Remark
2462	101.89	97.27	4.62			102	215	Average
2462	105.59	100.97	4.62			102	215	Peak
2483.52	44.25	39.59	4.66	54	-9.75	102	215	Average
2483.52	53.59	48.93	4.66	74	-20.41	102	215	Peak
4924	52.77	42.52	10.25	54	-1.23	234	84	Average
4924	54.13	43.88	10.25	74	-19.87	234	84	Peak
Antenna Polarity & Test Distance: Vertical at 3 m								
Frequency (MHz)	Emission Level (dBuV/m)	Read Level (dBuV)	Factor (dB/m)	Limit (dBuV/m)	Margin (dB)	Antenna Height (cm)	Table Angle (Degree)	Remark
2462	97.41	92.79	4.62			229	358	Average
2462	100.23	95.61	4.62			229	358	Peak
2483.36	42.41	37.75	4.66	54	-11.59	229	358	Average
2483.36	53.3	48.64	4.66	74	-20.7	229	358	Peak
4924	47.23	36.98	10.25	54	-6.77	283	43	Average
4924	50.08	39.83	10.25	74	-23.92	283	43	Peak

Remarks:

- Emission Level = Read Level + Factor
Margin value = Emission level – Limit value
- 2462 MHz: Fundamental frequency.
- The emission levels of other frequencies were very low against the limit.

802.11g

EUT Test Condition		Measurement Detail	
Channel	Channel 1	Frequency Range	1 GHz ~ 25 GHz
Input Power	120 Vac, 60 Hz	Detector Function	Peak (PK) Average (AV)
Environmental Conditions	25 deg. C, 65 % RH	Tested By	Karl Lee

Antenna Polarity & Test Distance: Horizontal at 3 m								
Frequency (MHz)	Emission Level (dBuV/m)	Read Level (dBuV)	Factor (dB/m)	Limit (dBuV/m)	Margin (dB)	Antenna Height (cm)	Table Angle (Degree)	Remark
2389.92	52.81	48.31	4.5	54	-1.19	129	261	Average
2389.92	69.86	65.36	4.5	74	-4.14	129	261	Peak
2412	95.68	91.13	4.55			129	261	Average
2412	103.68	99.13	4.55			129	261	Peak
4824	48.13	37.84	10.29	54	-5.87	237	81	Average
4824	54.43	44.14	10.29	74	-19.57	237	81	Peak
Antenna Polarity & Test Distance: Vertical at 3 m								
Frequency (MHz)	Emission Level (dBuV/m)	Read Level (dBuV)	Factor (dB/m)	Limit (dBuV/m)	Margin (dB)	Antenna Height (cm)	Table Angle (Degree)	Remark
2389.92	47.75	43.25	4.5	54	-6.25	262	358	Average
2389.92	64.41	59.91	4.5	74	-9.59	262	358	Peak
2412	90.42	85.87	4.55			262	358	Average
2412	97.83	93.28	4.55			262	358	Peak
4824	40.01	29.72	10.29	54	-13.99	310	43	Average
4824	51.63	41.34	10.29	74	-22.37	310	43	Peak

Remarks:

- Emission Level = Read Level + Factor
Margin value = Emission level – Limit value
- 2412 MHz: Fundamental frequency.
- The emission levels of other frequencies were very low against the limit.

EUT Test Condition		Measurement Detail	
Channel	Channel 6	Frequency Range	1 GHz ~ 25 GHz
Input Power	120 Vac, 60 Hz	Detector Function	Peak (PK) Average (AV)
Environmental Conditions	25 deg. C, 65 % RH	Tested By	Karl Lee

Antenna Polarity & Test Distance: Horizontal at 3 m								
Frequency (MHz)	Emission Level (dBuV/m)	Read Level (dBuV)	Factor (dB/m)	Limit (dBuV/m)	Margin (dB)	Antenna Height (cm)	Table Angle (Degree)	Remark
2389.65	46.89	42.4	4.49	54	-7.11	274	215	Average
2389.65	64.77	60.28	4.49	74	-9.23	274	215	Peak
2437	100.87	96.28	4.59			274	215	Average
2437	108.95	104.36	4.59			274	215	Peak
2483.64	45.76	41.1	4.66	54	-8.24	274	215	Average
2483.64	68.1	63.44	4.66	74	-5.9	274	215	Peak
4874	51.62	41.41	10.21	54	-2.38	237	81	Average
4874	62.75	52.54	10.21	74	-11.25	237	81	Peak

Antenna Polarity & Test Distance: Vertical at 3 m								
Frequency (MHz)	Emission Level (dBuV/m)	Read Level (dBuV)	Factor (dB/m)	Limit (dBuV/m)	Margin (dB)	Antenna Height (cm)	Table Angle (Degree)	Remark
2389.92	44.47	39.97	4.5	54	-9.53	280	358	Average
2389.92	62.69	58.19	4.5	74	-11.31	280	358	Peak
2437	95.62	91.03	4.59			280	358	Average
2437	104.18	99.59	4.59			280	358	Peak
2483.76	42.95	38.29	4.66	54	-11.05	280	358	Average
2483.76	62.66	58	4.66	74	-11.34	280	358	Peak
4874	47.34	37.13	10.21	54	-6.66	283	43	Average
4874	58.49	48.28	10.21	74	-15.51	283	43	Peak

Remarks:

- Emission Level = Read Level + Factor
Margin value = Emission level – Limit value
- 2437 MHz: Fundamental frequency.
- The emission levels of other frequencies were very low against the limit.

EUT Test Condition		Measurement Detail	
Channel	Channel 11	Frequency Range	1 GHz ~ 25 GHz
Input Power	120 Vac, 60 Hz	Detector Function	Peak (PK) Average (AV)
Environmental Conditions	25 deg. C, 65 % RH	Tested By	Karl Lee

Antenna Polarity & Test Distance: Horizontal at 3 m								
Frequency (MHz)	Emission Level (dBuV/m)	Read Level (dBuV)	Factor (dB/m)	Limit (dBuV/m)	Margin (dB)	Antenna Height (cm)	Table Angle (Degree)	Remark
2462	96.17	91.55	4.62			102	219	Average
2462	104.67	100.05	4.62			102	219	Peak
2483.52	52.96	48.3	4.66	54	-1.04	102	219	Average
2483.52	69.48	64.82	4.66	74	-4.52	102	219	Peak
4924	39.89	29.64	10.25	54	-14.11	237	81	Average
4924	51.22	40.97	10.25	74	-22.78	237	81	Peak
Antenna Polarity & Test Distance: Vertical at 3 m								
Frequency (MHz)	Emission Level (dBuV/m)	Read Level (dBuV)	Factor (dB/m)	Limit (dBuV/m)	Margin (dB)	Antenna Height (cm)	Table Angle (Degree)	Remark
2462	92.71	88.09	4.62			229	358	Average
2462	100.04	95.42	4.62			229	358	Peak
2483.52	48.86	44.2	4.66	54	-5.14	229	358	Average
2483.52	64.04	59.38	4.66	74	-9.96	229	358	Peak
4924	39.34	29.09	10.25	54	-14.66	283	43	Average
4924	49.82	39.57	10.25	74	-24.18	283	43	Peak

Remarks:

- Emission Level = Read Level + Factor
Margin value = Emission level – Limit value
- 2462 MHz: Fundamental frequency.
- The emission levels of other frequencies were very low against the limit.

802.11n (HT20)

EUT Test Condition		Measurement Detail	
Channel	Channel 1	Frequency Range	1 GHz ~ 25 GHz
Input Power	120 Vac, 60 Hz	Detector Function	Peak (PK) Average (AV)
Environmental Conditions	25 deg. C, 65 % RH	Tested By	Karl Lee

Antenna Polarity & Test Distance: Horizontal at 3 m

Frequency (MHz)	Emission Level (dBuV/m)	Read Level (dBuV)	Factor (dB/m)	Limit (dBuV/m)	Margin (dB)	Antenna Height (cm)	Table Angle (Degree)	Remark
2389.92	52.29	47.79	4.5	54	-1.71	129	261	Average
2389.92	66.41	61.91	4.5	74	-7.59	129	261	Peak
2412	94.61	90.06	4.55			129	261	Average
2412	102.81	98.26	4.55			129	261	Peak
4824	41.87	31.58	10.29	54	-12.13	146	66	Average
4824	49.33	39.04	10.29	74	-24.67	146	66	Peak

Antenna Polarity & Test Distance: Vertical at 3 m

Frequency (MHz)	Emission Level (dBuV/m)	Read Level (dBuV)	Factor (dB/m)	Limit (dBuV/m)	Margin (dB)	Antenna Height (cm)	Table Angle (Degree)	Remark
2389.92	46.96	42.46	4.5	54	-7.04	262	358	Average
2389.92	60.65	56.15	4.5	74	-13.35	262	358	Peak
2412	89.42	84.87	4.55			262	358	Average
2412	97.45	92.9	4.55			262	358	Peak
4824	42.54	32.25	10.29	54	-11.46	154	145	Average
4824	48.21	37.92	10.29	74	-25.79	154	145	Peak

Remarks:

- Emission Level = Read Level + Factor
Margin value = Emission level – Limit value
- 2412 MHz: Fundamental frequency.
- The emission levels of other frequencies were very low against the limit.

EUT Test Condition		Measurement Detail	
Channel	Channel 6	Frequency Range	1 GHz ~ 25 GHz
Input Power	120 Vac, 60 Hz	Detector Function	Peak (PK) Average (AV)
Environmental Conditions	25 deg. C, 65 % RH	Tested By	Karl Lee

Antenna Polarity & Test Distance: Horizontal at 3 m								
Frequency (MHz)	Emission Level (dBuV/m)	Read Level (dBuV)	Factor (dB/m)	Limit (dBuV/m)	Margin (dB)	Antenna Height (cm)	Table Angle (Degree)	Remark
2389.83	47.77	43.27	4.5	54	-6.23	274	215	Average
2389.83	63.16	58.66	4.5	74	-10.84	274	215	Peak
2437	100.64	96.05	4.59			274	215	Average
2437	109.78	105.19	4.59			274	215	Peak
2483.6	46.91	42.25	4.66	54	-7.09	274	215	Average
2483.6	62.86	58.2	4.66	74	-11.14	274	215	Peak
4874	50.82	40.61	10.21	54	-3.18	237	81	Average
4874	61.56	51.35	10.21	74	-12.44	237	81	Peak

Antenna Polarity & Test Distance: Vertical at 3 m								
Frequency (MHz)	Emission Level (dBuV/m)	Read Level (dBuV)	Factor (dB/m)	Limit (dBuV/m)	Margin (dB)	Antenna Height (cm)	Table Angle (Degree)	Remark
2389.92	45.65	41.15	4.5	54	-8.35	280	358	Average
2389.92	60.99	56.49	4.5	74	-13.01	280	358	Peak
2437	95.14	90.55	4.59			280	358	Average
2437	103.12	98.53	4.59			280	358	Peak
2483.52	43.73	39.07	4.66	54	-10.27	280	358	Average
2483.52	57.81	53.15	4.66	74	-16.19	280	358	Peak
4874	46.92	36.71	10.21	54	-7.08	283	43	Average
4874	57.5	47.29	10.21	74	-16.5	283	43	Peak

Remarks:

- Emission Level = Read Level + Factor
Margin value = Emission level – Limit value
- 2437 MHz: Fundamental frequency.
- The emission levels of other frequencies were very low against the limit.

EUT Test Condition		Measurement Detail	
Channel	Channel 11	Frequency Range	1 GHz ~ 25 GHz
Input Power	120 Vac, 60 Hz	Detector Function	Peak (PK) Average (AV)
Environmental Conditions	25 deg. C, 65 % RH	Tested By	Karl Lee

Antenna Polarity & Test Distance: Horizontal at 3 m								
Frequency (MHz)	Emission Level (dBuV/m)	Read Level (dBuV)	Factor (dB/m)	Limit (dBuV/m)	Margin (dB)	Antenna Height (cm)	Table Angle (Degree)	Remark
2462	95.02	90.4	4.62			102	219	Average
2462	103.84	99.22	4.62			102	219	Peak
2483.56	52.42	47.76	4.66	54	-1.58	102	219	Average
2483.56	68.24	63.58	4.66	74	-5.76	102	219	Peak
4924	42.1	31.85	10.25	54	-11.9	148	99	Average
4924	47.93	37.68	10.25	74	-26.07	148	99	Peak
Antenna Polarity & Test Distance: Vertical at 3 m								
Frequency (MHz)	Emission Level (dBuV/m)	Read Level (dBuV)	Factor (dB/m)	Limit (dBuV/m)	Margin (dB)	Antenna Height (cm)	Table Angle (Degree)	Remark
2462	91.46	86.84	4.62			229	358	Average
2462	100.28	95.66	4.62			229	358	Peak
2483.52	47.57	42.91	4.66	54	-6.43	229	358	Average
2483.52	62.7	58.04	4.66	74	-11.3	229	358	Peak
4924	41.51	31.26	10.25	54	-12.49	145	55	Average
4924	48.65	38.4	10.25	74	-25.35	145	55	Peak

Remarks:

- Emission Level = Read Level + Factor
Margin value = Emission level – Limit value
- 2462 MHz: Fundamental frequency.
- The emission levels of other frequencies were very low against the limit.

802.11n (HT40)

EUT Test Condition		Measurement Detail	
Channel	Channel 3	Frequency Range	1 GHz ~ 25 GHz
Input Power	120 Vac, 60 Hz	Detector Function	Peak (PK) Average (AV)
Environmental Conditions	25 deg. C, 65 % RH	Tested By	Karl Lee

Antenna Polarity & Test Distance: Horizontal at 3 m								
Frequency (MHz)	Emission Level (dBuV/m)	Read Level (dBuV)	Factor (dB/m)	Limit (dBuV/m)	Margin (dB)	Antenna Height (cm)	Table Angle (Degree)	Remark
2389.02	52.49	15.54	36.95	54	-1.51	127	213	Average
2389.02	67.04	62.55	4.49	74	-6.96	127	213	Peak
2422	91.2	86.64	4.56			127	213	Average
2422	98.74	94.18	4.56			127	213	Peak
2489.64	41.26	36.58	4.68	54	-12.74	127	213	Average
2489.64	52.71	48.03	4.68	74	-21.29	127	213	Peak
4844	42.58	32.35	10.23	54	-11.42	153	266	Average
4844	48.08	37.85	10.23	74	-25.92	153	266	Peak
Antenna Polarity & Test Distance: Vertical at 3 m								
Frequency (MHz)	Emission Level (dBuV/m)	Read Level (dBuV)	Factor (dB/m)	Limit (dBuV/m)	Margin (dB)	Antenna Height (cm)	Table Angle (Degree)	Remark
2389.29	49.02	44.53	4.49	54	-4.98	262	358	Average
2389.29	63.22	58.73	4.49	74	-10.78	262	358	Peak
2422	87.16	82.6	4.56			262	358	Average
2422	94.57	90.01	4.56			262	358	Peak
2484.52	40.97	36.31	4.66	54	-13.03	262	358	Average
2484.52	52.06	47.4	4.66	74	-21.94	262	358	Peak
4844	42.28	32.05	10.23	54	-11.72	185	77	Average
4844	48.01	37.78	10.23	74	-25.99	185	77	Peak

Remarks:

- Emission Level = Read Level + Factor
Margin value = Emission level – Limit value
- 2422 MHz: Fundamental frequency.
- The emission levels of other frequencies were very low against the limit.

EUT Test Condition		Measurement Detail	
Channel	Channel 6	Frequency Range	1 GHz ~ 25 GHz
Input Power	120 Vac, 60 Hz	Detector Function	Peak (PK) Average (AV)
Environmental Conditions	25 deg. C, 65 % RH	Tested By	Karl Lee

Antenna Polarity & Test Distance: Horizontal at 3 m								
Frequency (MHz)	Emission Level (dBuV/m)	Read Level (dBuV)	Factor (dB/m)	Limit (dBuV/m)	Margin (dB)	Antenna Height (cm)	Table Angle (Degree)	Remark
2389.92	52.78	48.28	4.5	54	-1.22	274	215	Average
2389.92	67	62.5	4.5	74	-7	274	215	Peak
2437	93.01	88.42	4.59			274	215	Average
2437	101.9	97.31	4.59			274	215	Peak
2483.52	51.85	47.19	4.66	54	-2.15	274	215	Average
2483.52	68.52	63.86	4.66	74	-5.48	274	215	Peak
4874	42.64	32.43	10.21	54	-11.36	163	349	Average
4874	57.85	47.64	10.21	74	-16.15	163	349	Peak

Antenna Polarity & Test Distance: Vertical at 3 m								
Frequency (MHz)	Emission Level (dBuV/m)	Read Level (dBuV)	Factor (dB/m)	Limit (dBuV/m)	Margin (dB)	Antenna Height (cm)	Table Angle (Degree)	Remark
2389.83	49.48	44.98	4.5	54	-4.52	280	358	Average
2389.83	63.26	58.76	4.5	74	-10.74	280	358	Peak
2437	87.2	82.61	4.59			280	358	Average
2437	95.09	90.5	4.59			280	358	Peak
2483.52	46.91	42.25	4.66	54	-7.09	280	358	Average
2483.52	62.48	57.82	4.66	74	-11.52	280	358	Peak
4874	43.45	33.24	10.21	54	-10.55	154	185	Average
4874	51.54	41.33	10.21	74	-22.46	154	185	Peak

Remarks:

- Emission Level = Read Level + Factor
Margin value = Emission level – Limit value
- 2437 MHz: Fundamental frequency.
- The emission levels of other frequencies were very low against the limit.

EUT Test Condition		Measurement Detail	
Channel	Channel 9	Frequency Range	1 GHz ~ 25 GHz
Input Power	120 Vac, 60 Hz	Detector Function	Peak (PK) Average (AV)
Environmental Conditions	25 deg. C, 65 % RH	Tested By	Karl Lee

Antenna Polarity & Test Distance: Horizontal at 3 m								
Frequency (MHz)	Emission Level (dBuV/m)	Read Level (dBuV)	Factor (dB/m)	Limit (dBuV/m)	Margin (dB)	Antenna Height (cm)	Table Angle (Degree)	Remark
2381.73	41.33	36.86	4.47	54	-12.67	102	219	Average
2381.73	52.29	47.82	4.47	74	-21.71	102	219	Peak
2452	90.22	85.62	4.6			102	219	Average
2452	99.52	94.92	4.6			102	219	Peak
2484.08	52.34	47.68	4.66	54	-1.66	102	219	Average
2484.08	66.47	61.81	4.66	74	-7.53	102	219	Peak
4904	42.55	32.41	10.14	54	-11.45	185	244	Average
4904	48.33	38.19	10.14	74	-25.67	185	244	Peak

Antenna Polarity & Test Distance: Vertical at 3 m								
Frequency (MHz)	Emission Level (dBuV/m)	Read Level (dBuV)	Factor (dB/m)	Limit (dBuV/m)	Margin (dB)	Antenna Height (cm)	Table Angle (Degree)	Remark
2376.15	40.9	36.43	4.47	54	-13.1	229	358	Average
2376.15	52.45	47.98	4.47	74	-21.55	229	358	Peak
2452	86.32	81.72	4.6			229	358	Average
2452	94.43	89.83	4.6			229	358	Peak
2483.84	46.96	42.3	4.66	54	-7.04	229	358	Average
2483.84	60.79	56.13	4.66	74	-13.21	229	358	Peak
4904	42.4	32.26	10.14	54	-11.6	144	186	Average
4904	48.29	38.15	10.14	74	-25.71	144	186	Peak

Remarks:

- Emission Level = Read Level + Factor
Margin value = Emission level – Limit value
- 2452 MHz: Fundamental frequency.
- The emission levels of other frequencies were very low against the limit.

9 kHz ~ 30 MHz Data:

The amplitude of spurious emissions attenuated more than 20 dB below the permissible value is not required to be report.

30 MHz ~ 1 GHz Worst-Case Data:

802.11g

EUT Test Condition		Measurement Detail	
Channel	Channel 11	Frequency Range	30 MHz ~ 1 GHz
Input Power	120 Vac, 60 Hz	Detector Function	Peak (PK) Quasi-peak (QP)
Environmental Conditions	25 deg. C, 65 % RH	Tested By	Karl Lee

Horizontal

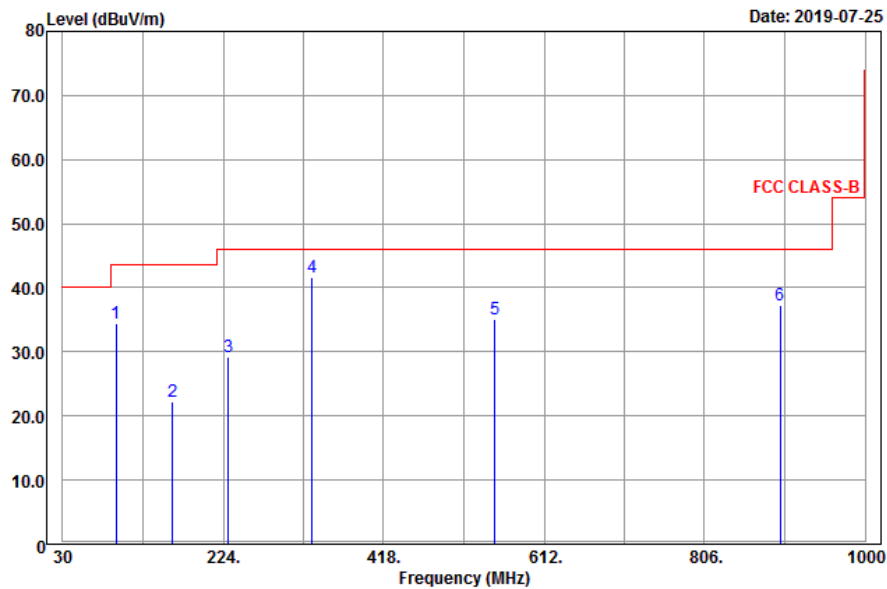

Vertical

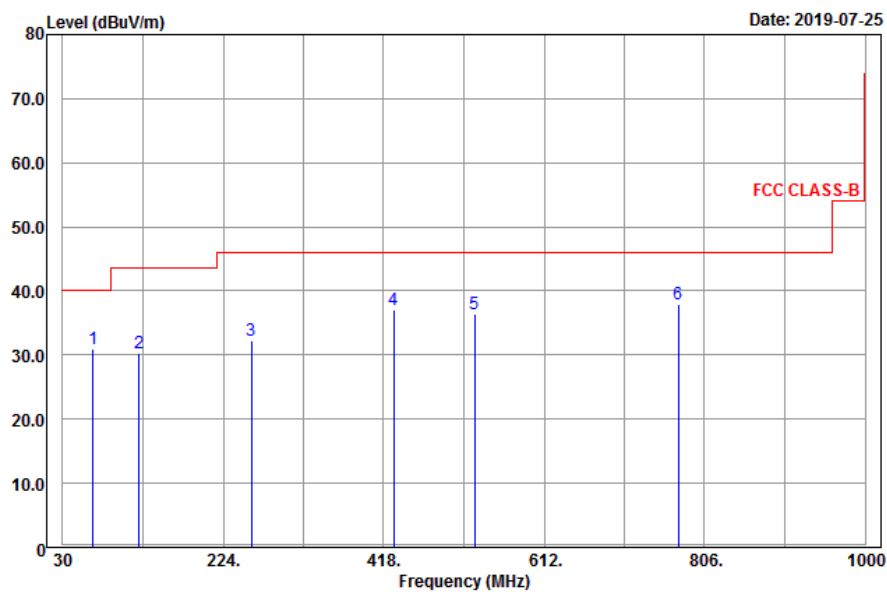

Antenna Polarity & Test Distance: Horizontal at 3 m								
Frequency (MHz)	Emission Level (dBuV/m)	Read Level (dBuV)	Factor (dB/m)	Limit (dBuV/m)	Margin (dB)	Antenna Height (cm)	Table Angle (Degree)	Remark
94.53	34.41	52.26	-17.85	43.5	-9.09	126	108	Peak
163.11	22.26	42.79	-20.53	43.5	-21.24	184	135	Peak
230.61	29.3	46.66	-17.36	46	-16.7	172	262	Peak
331.5	41.56	56.78	-15.22	46	-4.44	125	133	Peak
552.7	35.13	46.65	-11.52	46	-10.87	168	137	Peak
897.1	37.38	43.35	-5.97	46	-8.62	172	116	Peak
Antenna Polarity & Test Distance: Vertical at 3 m								
Frequency (MHz)	Emission Level (dBuV/m)	Read Level (dBuV)	Factor (dB/m)	Limit (dBuV/m)	Margin (dB)	Antenna Height (cm)	Table Angle (Degree)	Remark
66.99	31.06	49.39	-18.33	40	-8.94	162	138	Peak
122.61	30.34	49.99	-19.65	43.5	-13.16	176	45	Peak
258.15	32.22	48.92	-16.7	46	-13.78	193	28	Peak
430.2	36.98	50.5	-13.52	46	-9.02	182	133	Peak
528.2	36.44	48.34	-11.9	46	-9.56	187	126	Peak
774.6	37.96	46.15	-8.19	46	-8.04	140	310	Peak

Remarks:

- Emission Level = Read Level + Factor
Margin value = Emission level – Limit value.
- The emission levels of other frequencies were very low against the limit.

4.2 Conducted Emission Measurement

4.2.1 Limits of Conducted Emission Measurement

Frequency (MHz)	Conducted Limit (dBuV)	
	Quasi-Peak	Average
0.15 - 0.5	66 - 56	56 - 46
0.50 - 5.0	56	46
5.0 - 30.0	60	50

- Note: 1. The lower limit shall apply at the transition frequencies.
 2. The limit decreases in line with the logarithm of the frequency in the range of 0.15 to 0.50 MHz.

4.2.2 Test Instruments

Description & Manufacturer	Model No.	Serial No.	Date of Calibration	Due Date of Calibration
Test Receiver ROHDE & SCHWARZ	ESCI	100613	Dec. 10, 2018	Dec. 09, 2019
RF signal cable Woken	5D-FB	Cable-cond1-01	Sep. 05, 2019	Sep. 04, 2020
LISN ROHDE & SCHWARZ (EUT)	ENV216	101826	Feb. 21, 2019	Feb. 20, 2020
LISN ROHDE & SCHWARZ (Peripheral)	ESH3-Z5	100311	Aug. 22, 2019	Aug. 21, 2020
Software ADT	BV ADT_Cond_ V7.3.7.4	NA	NA	NA

- Note: 1. The calibration interval of the above test instruments is 12 months and the calibrations are traceable to NML/ROC and NIST/USA.
 2. The test was performed in HwaYa Shielded Room 1.
 3. The VCCI Site Registration No. is C-12040.

4.2.3 Test Procedures

- a. The EUT was placed 0.4 meters from the conducting wall of the shielded room with EUT being connected to the power mains through a line impedance stabilization network (LISN). Other support units were connected to the power mains through another LISN. The two LISNs provide 50 ohm/50 uH of coupling impedance for the measuring instrument.
- b. Both lines of the power mains connected to the EUT were checked for maximum conducted interference.
- c. The frequency range from 150 kHz to 30 MHz was searched. Emission levels under (Limit – 20 dB) was not recorded.

Note: The resolution bandwidth and video bandwidth of test receiver is 9 kHz for quasi-peak detection (QP) and average detection (AV) at frequency 0.15 MHz – 30 MHz.

4.2.4 Deviation from Test Standard

No deviation.

4.2.5 Test Setup

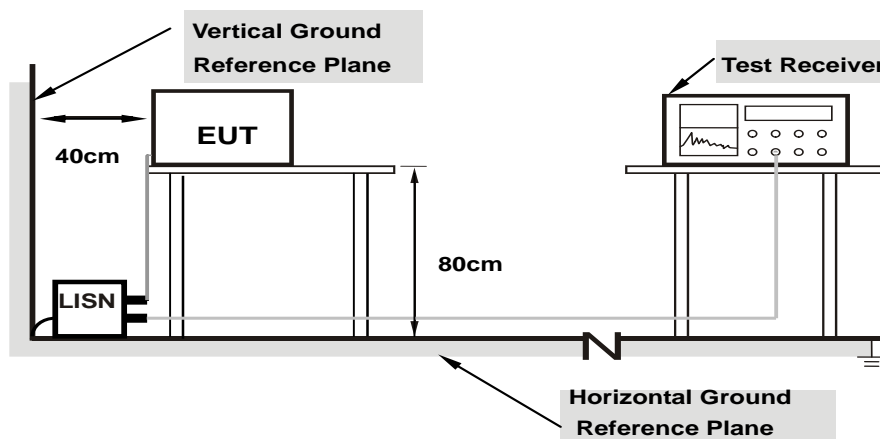

Note: 1.Support units were connected to second LISN.

For the actual test configuration, please refer to the attached file (Test Setup Photo).

4.2.6 EUT Operating Conditions

- a. Placed the EUT on a testing table.
- b. Use the software to control the EUT under transmission condition continuously at specific channel frequency.

4.2.7 Test Results

Mode A

Frequency Range	150kHz ~ 30MHz	Detector Function & Resolution Bandwidth	Quasi-Peak (QP) / Average (AV), 9kHz
Input Power	120Vac, 60Hz	Environmental Conditions	25°C, 65%RH
Tested by	Thomas Wei	Test Date	2019/10/3

Phase Of Power : Line (L)										
No	Frequency (MHz)	Correction Factor (dB)	Reading Value (dBuV)		Emission Level (dBuV)		Limit (dBuV)		Margin (dB)	
			Q.P.	AV.	Q.P.	AV.	Q.P.	AV.	Q.P.	AV.
1	0.15782	9.67	39.43	25.66	49.10	35.33	65.58	55.58	-16.48	-20.25
2	0.17737	9.66	39.98	25.88	49.64	35.54	64.61	54.61	-14.97	-19.07
3	0.20084	9.66	30.31	15.28	39.97	24.94	63.58	53.58	-23.61	-28.64
4	0.22820	9.66	29.36	16.98	39.02	26.64	62.51	52.51	-23.49	-25.87
5	0.24775	9.67	26.25	15.16	35.92	24.83	61.83	51.83	-25.91	-27.00
6	22.41745	9.99	19.20	7.63	29.19	17.62	60.00	50.00	-30.81	-32.38

Remarks:

1. Q.P. and AV. are abbreviations of quasi-peak and average individually.
2. The emission levels of other frequencies were very low against the limit.
3. Margin value = Emission level – Limit value
4. Correction factor = Insertion loss + Cable loss
5. Emission Level = Correction Factor + Reading Value

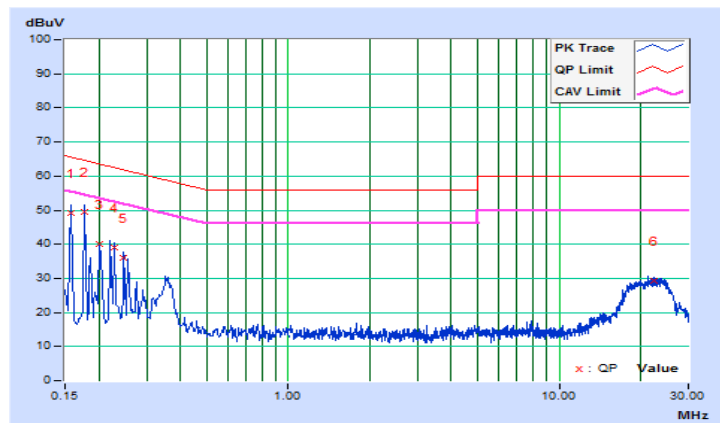

Frequency Range	150kHz ~ 30MHz	Detector Function & Resolution Bandwidth	Quasi-Peak (QP) / Average (AV), 9kHz
Input Power	120Vac, 60Hz	Environmental Conditions	25°C, 65%RH
Tested by	Thomas Wei	Test Date	2019/10/3

Phase Of Power : Neutral (N)										
No	Frequency (MHz)	Correction Factor (dB)	Reading Value (dBuV)		Emission Level (dBuV)		Limit (dBuV)		Margin (dB)	
			Q.P.	AV.	Q.P.	AV.	Q.P.	AV.	Q.P.	AV.
1	0.15391	9.64	32.75	25.51	42.39	35.15	65.79	55.79	-23.40	-20.64
2	0.18122	9.64	30.54	22.02	40.18	31.66	64.43	54.43	-24.25	-22.77
3	0.22082	9.64	29.66	18.51	39.30	28.15	62.79	52.79	-23.49	-24.64
4	0.25166	9.65	24.11	17.05	33.76	26.70	61.70	51.70	-27.94	-25.00
5	0.34926	9.65	17.67	5.44	27.32	15.09	58.98	48.98	-31.66	-33.89
6	22.17503	10.07	18.79	7.20	28.86	17.27	60.00	50.00	-31.14	-32.73

Remarks:

1. Q.P. and AV. are abbreviations of quasi-peak and average individually.
2. The emission levels of other frequencies were very low against the limit.
3. Margin value = Emission level – Limit value
4. Correction factor = Insertion loss + Cable loss
5. Emission Level = Correction Factor + Reading Value

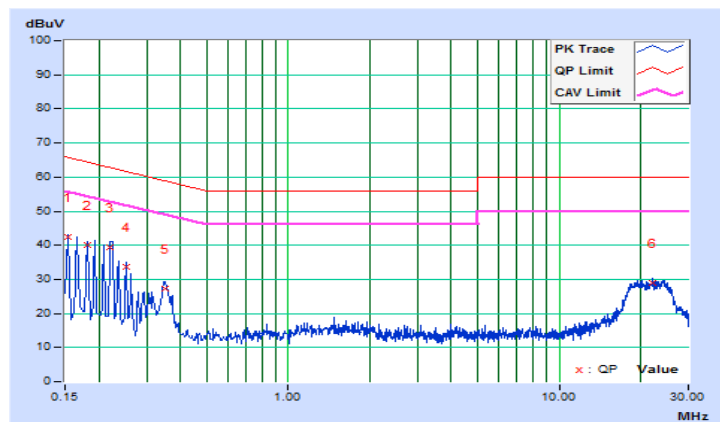

Mode B

Frequency Range	150kHz ~ 30MHz	Detector Function & Resolution Bandwidth	Quasi-Peak (QP) / Average (AV), 9kHz
Input Power	120Vac, 60Hz	Environmental Conditions	25°C, 65%RH
Tested by	Thomas Wei	Test Date	2019/10/3

Phase Of Power : Line (L)										
No	Frequency (MHz)	Correction Factor (dB)	Reading Value (dBuV)		Emission Level (dBuV)		Limit (dBuV)		Margin (dB)	
			Q.P.	AV.	Q.P.	AV.	Q.P.	AV.	Q.P.	AV.
1	0.15391	9.67	40.77	32.77	50.44	42.44	65.79	55.79	-15.35	-13.35
2	0.18128	9.66	39.30	28.64	48.96	38.30	64.43	54.43	-15.47	-16.13
3	0.20865	9.66	34.52	24.12	44.18	33.78	63.26	53.26	-19.08	-19.48
4	0.22434	9.66	31.48	23.65	41.14	33.31	62.66	52.66	-21.52	-19.35
5	0.36048	9.68	18.96	9.23	28.64	18.91	58.72	48.72	-30.08	-29.81
6	24.04010	10.00	18.17	7.90	28.17	17.90	60.00	50.00	-31.83	-32.10

Remarks:

1. Q.P. and AV. are abbreviations of quasi-peak and average individually.
2. The emission levels of other frequencies were very low against the limit.
3. Margin value = Emission level – Limit value
4. Correction factor = Insertion loss + Cable loss
5. Emission Level = Correction Factor + Reading Value

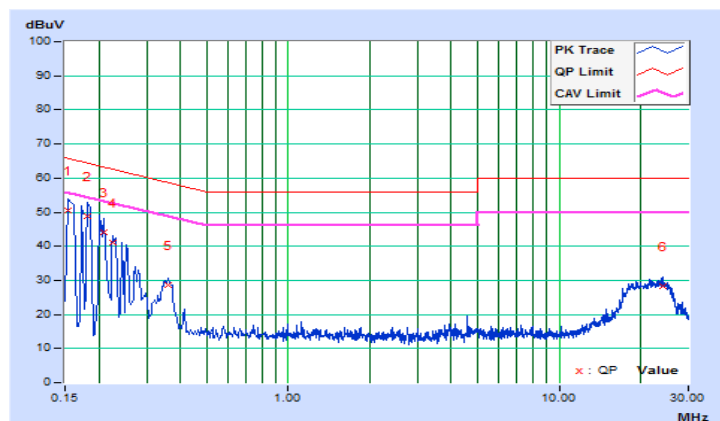

Frequency Range	150kHz ~ 30MHz	Detector Function & Resolution Bandwidth	Quasi-Peak (QP) / Average (AV), 9kHz
Input Power	120Vac, 60Hz	Environmental Conditions	25°C, 65%RH
Tested by	Thomas Wei	Test Date	2019/10/3

Phase Of Power : Neutral (N)										
No	Frequency (MHz)	Correction Factor (dB)	Reading Value (dBuV)		Emission Level (dBuV)		Limit (dBuV)		Margin (dB)	
			Q.P.	AV.	Q.P.	AV.	Q.P.	AV.	Q.P.	AV.
1	0.16955	9.64	39.46	30.52	49.10	40.16	64.98	54.98	-15.88	-14.82
2	0.18519	9.64	31.18	23.52	40.82	33.16	64.25	54.25	-23.43	-21.09
3	0.21256	9.64	28.92	20.71	38.56	30.35	63.10	53.10	-24.54	-22.75
4	0.23993	9.64	28.40	21.17	38.04	30.81	62.10	52.10	-24.06	-21.29
5	0.34941	9.65	16.80	5.68	26.45	15.33	58.98	48.98	-32.53	-33.65
6	23.86024	10.08	18.86	7.58	28.94	17.66	60.00	50.00	-31.06	-32.34

Remarks:

1. Q.P. and AV. are abbreviations of quasi-peak and average individually.
2. The emission levels of other frequencies were very low against the limit.
3. Margin value = Emission level – Limit value
4. Correction factor = Insertion loss + Cable loss
5. Emission Level = Correction Factor + Reading Value

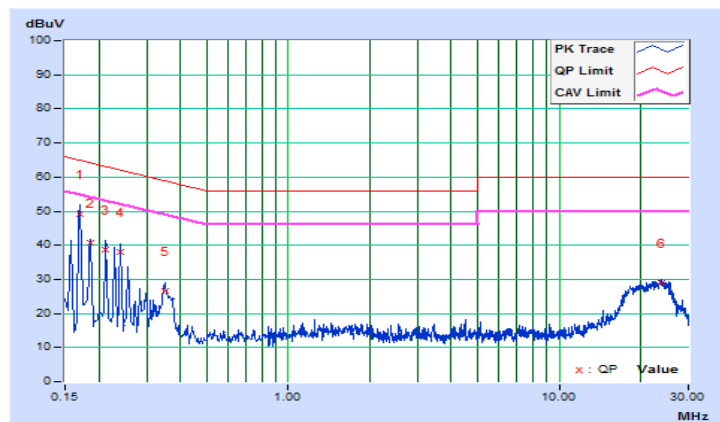

4.3 6 dB Bandwidth Measurement

4.3.1 Limits of 6 dB Bandwidth Measurement

The minimum of 6 dB Bandwidth Measurement is 0.5 MHz.

4.3.2 Test Setup

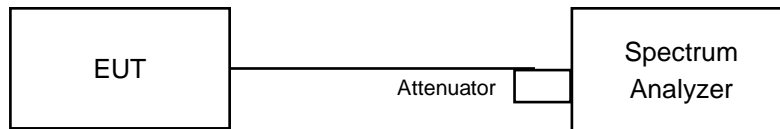

4.3.3 Test Instruments

Refer to section 4.1.2 to get information of above instrument.

4.3.4 Test Procedure

- Set resolution bandwidth (RBW) = 100 kHz
- Set the video bandwidth (VBW) $\geq 3 \times$ RBW, Detector = Peak.
- Trace mode = max hold.
- Sweep = auto couple.
- Measure the maximum width of the emission that is constrained by the frequencies associated with the two amplitude points (upper and lower) that are attenuated by 6 dB relative to the maximum level measured in the fundamental emission

4.3.5 Deviation from Test Standard

No deviation.

4.3.6 EUT Operating Conditions

The software provided by client to enable the EUT under transmission condition continuously at lowest, middle and highest channel frequencies individually.

4.3.7 Test Results

802.11b

Channel	Frequency (MHz)	6 dB Bandwidth (MHz)	Minimum Limit (MHz)	Pass / Fail
1	2412	10.12	0.5	Pass
6	2437	10.16	0.5	Pass
11	2462	10.10	0.5	Pass

802.11g

Channel	Frequency (MHz)	6 dB Bandwidth (MHz)	Minimum Limit (MHz)	Pass / Fail
1	2412	16.34	0.5	Pass
6	2437	16.33	0.5	Pass
11	2462	16.56	0.5	Pass

802.11n (HT20)

Channel	Frequency (MHz)	6 dB Bandwidth (MHz)	Minimum Limit (MHz)	Pass / Fail
1	2412	17.30	0.5	Pass
6	2437	16.59	0.5	Pass
11	2462	17.66	0.5	Pass

802.11n (HT40)

Channel	Frequency (MHz)	6 dB Bandwidth (MHz)	Minimum Limit (MHz)	Pass / Fail
3	2422	35.57	0.5	Pass
6	2437	35.26	0.5	Pass
9	2452	36.54	0.5	Pass

Spectrum Plot of Worst Value

802.11b

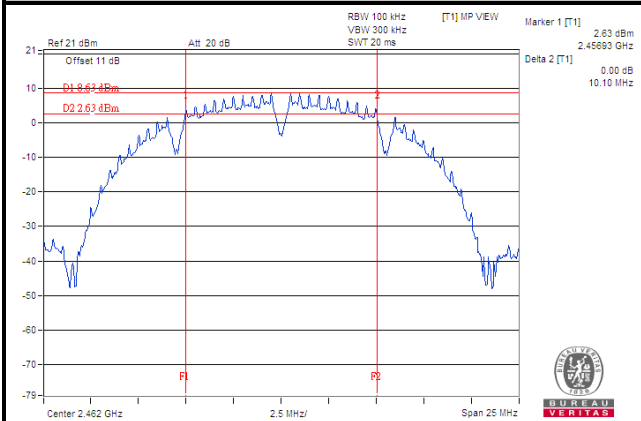

802.11g

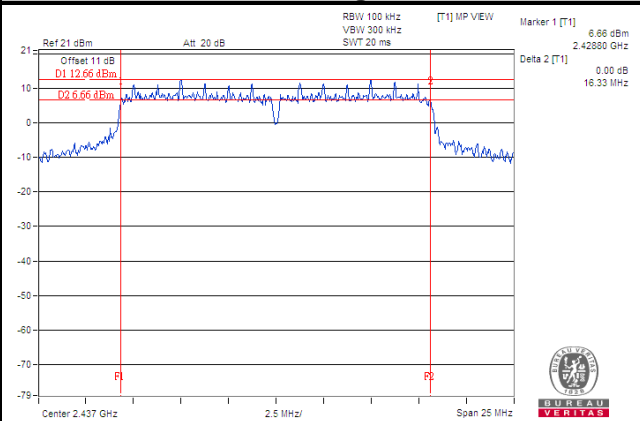

802.11n (HT20)

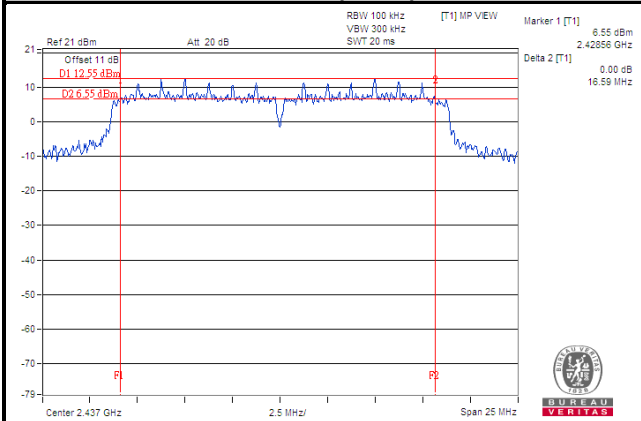

802.11n (HT40)

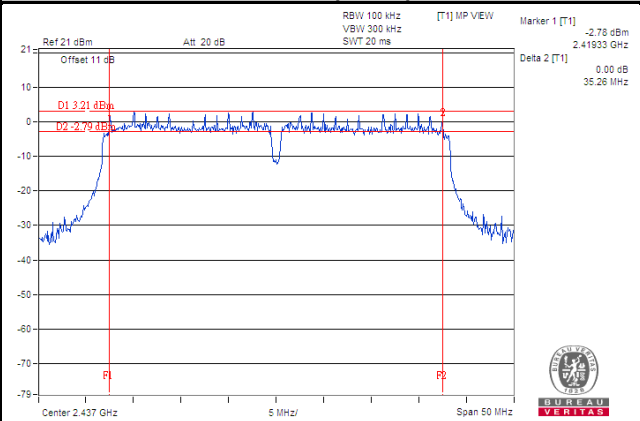

4.4 Occupied Bandwidth Measurement

4.4.1 Test Setup

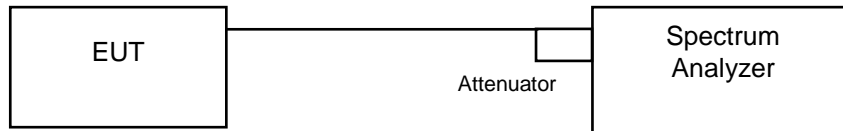

4.4.2 Test Instruments

Refer to section 4.1.2 to get information of above instrument.

4.4.3 Test Procedure

The transmitter output was connected to the spectrum analyzer through an attenuator. The bandwidth of the fundamental frequency was measured by spectrum analyzer with resolution bandwidth in the range of 1 % to 5 % of the anticipated emission bandwidth, and a video bandwidth at least 3x the resolution bandwidth and set the detector to PEAK. The width of a frequency band such that, below the lower and above the upper frequency limits, the mean powers emitted are each equal to a specified percentage 0.5 % of the total mean power of a given emission.

4.4.4 Deviation from Test Standard

No deviation.

4.4.5 EUT Operating Conditions

The software provided by client to enable the EUT under transmission condition continuously at lowest, middle and highest channel frequencies individually.

4.4.6 Test Results

802.11b

Channel	Frequency (MHz)	Occupied Bandwidth (MHz)	Pass / Fail
1	2412	15.10	Pass
6	2437	15.10	Pass
11	2462	15.00	Pass

802.11g

Channel	Frequency (MHz)	Occupied Bandwidth (MHz)	Pass / Fail
1	2412	16.93	Pass
6	2437	25.86	Pass
11	2462	16.73	Pass

802.11n (HT20)

Channel	Frequency (MHz)	Occupied Bandwidth (MHz)	Pass / Fail
1	2412	17.98	Pass
6	2437	26.16	Pass
11	2462	17.79	Pass

802.11n (HT40)

Channel	Frequency (MHz)	Occupied Bandwidth (MHz)	Pass / Fail
3	2422	36.83	Pass
6	2437	36.92	Pass
9	2452	36.73	Pass

Spectrum Plot of Worst Value

802.11b

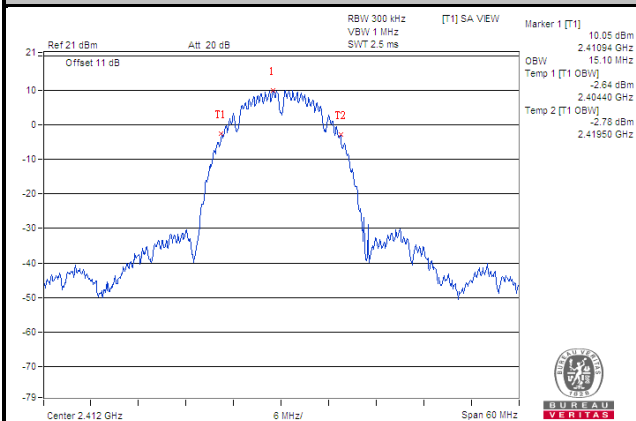

802.11g

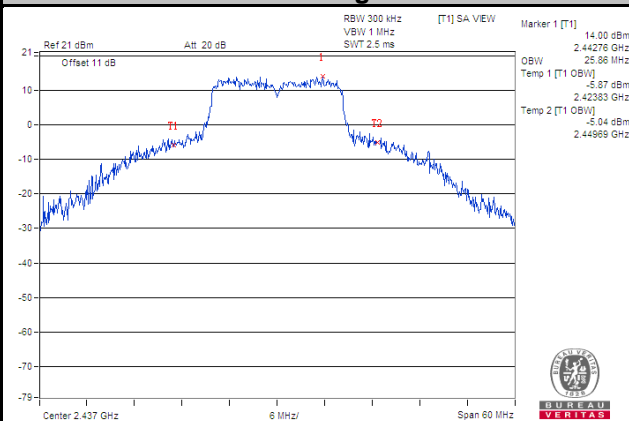

802.11n (HT20)

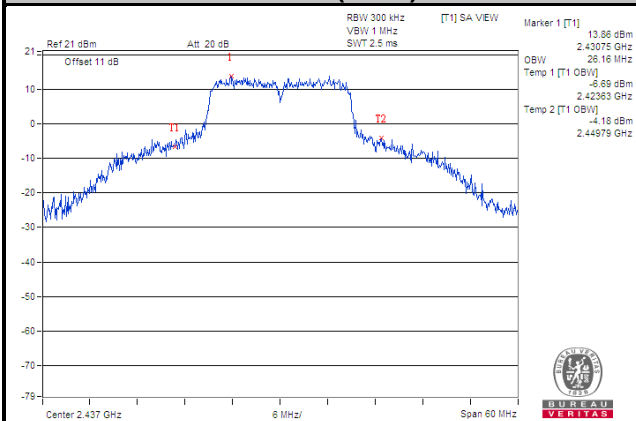

802.11n (HT40)

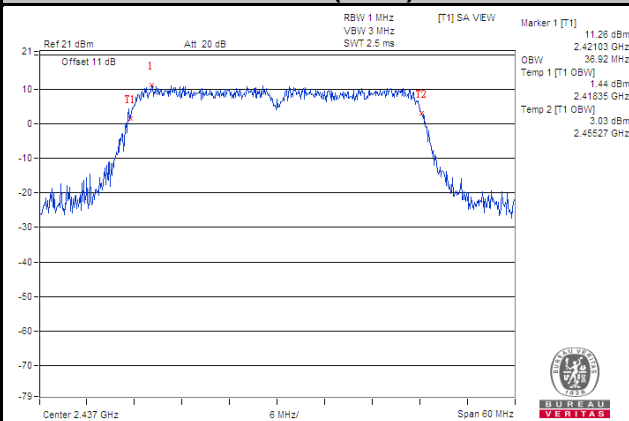

4.5 Conducted Output Power Measurement

4.5.1 Limits of Conducted Output Power Measurement

For systems using digital modulation in the 2400–2483.5 MHz bands: 1 Watt (30 dBm)

4.5.2 Test Setup

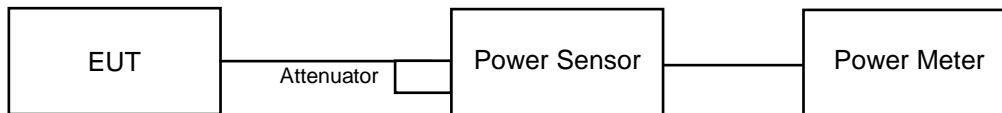

4.5.3 Test Instruments

Refer to section 4.1.2 to get information of above instrument.

4.5.4 Test Procedures

A peak power sensor was used on the output port of the EUT. A power meter was used to read the response of the peak power sensor. Record the power level.

4.5.5 Deviation from Test Standard

No deviation.

4.5.6 EUT Operating Conditions

The software provided by client to enable the EUT under transmission condition continuously at lowest, middle and highest channel frequencies individually.

4.5.7 Test Results

802.11b

Channel	Frequency (MHz)	Peak Power (mW)	Peak Power (dBm)	Limit (dBm)	Pass / Fail
1	2412	108.893	20.37	30	Pass
6	2437	142.889	21.55	30	Pass
11	2462	115.345	20.62	30	Pass

802.11g

Channel	Frequency (MHz)	Peak Power (mW)	Peak Power (dBm)	Limit (dBm)	Pass / Fail
1	2412	201.372	23.04	30	Pass
6	2437	392.645	25.94	30	Pass
11	2462	229.087	23.60	30	Pass

802.11n (HT20)

Channel	Frequency (MHz)	Peak Power (mW)	Peak Power (dBm)	Limit (dBm)	Pass / Fail
1	2412	252.348	24.02	30	Pass
6	2437	388.15	25.89	30	Pass
11	2462	211.349	23.25	30	Pass

802.11n (HT40)

Channel	Frequency (MHz)	Peak Power (mW)	Peak Power (dBm)	Limit (dBm)	Pass / Fail
3	2422	253.513	24.04	30	Pass
6	2437	240.436	23.81	30	Pass
9	2452	138.038	21.40	30	Pass

4.6 Power Spectral Density Measurement

4.6.1 Limits of Power Spectral Density Measurement

The Maximum of Power Spectral Density Measurement is 8 dBm in any 3 kHz band during any time interval of continuous transmission.

4.6.2 Test Setup

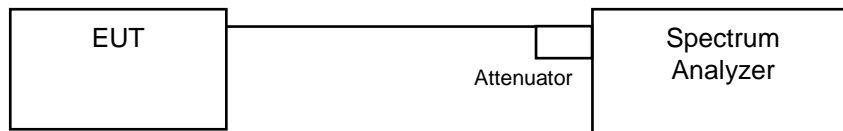

4.6.3 Test Instruments

Refer to section 4.1.2 to get information of above instrument.

4.6.4 Test Procedure

- a. Set analyzer center frequency to DTS channel center frequency.
- b. Set the span to 1.5 times the DTS bandwidth.
- c. Set the RBW to: $3 \text{ kHz} \leq \text{RBW} \leq 100 \text{ kHz}$.
- d. Set the VBW $\geq 3 \times \text{RBW}$.
- e. Detector = peak.
- f. Sweep time = auto couple.
- g. Trace mode = max hold.
- h. Allow trace to fully stabilize.
- i. Use the peak marker function to determine the maximum amplitude level within the RBW.

4.6.5 Deviation from Test Standard

No deviation.

4.6.6 EUT Operating Condition

The software provided by client to enable the EUT under transmission condition continuously at lowest, middle and highest channel frequencies individually.

4.6.7 Test Results

802.11b

Channel	Frequency (MHz)	PSD (dBm/3 kHz)	Limit (dBm/3 kHz)	Pass / Fail
1	2412	-4.20	8	Pass
6	2437	-3.40	8	Pass
11	2462	-5.41	8	Pass

802.11g

Channel	Frequency (MHz)	PSD (dBm/3 kHz)	Limit (dBm/3 kHz)	Pass / Fail
1	2412	-8.05	8	Pass
6	2437	-3.43	8	Pass
11	2462	-9.77	8	Pass

802.11n (HT20)

Channel	Frequency (MHz)	PSD (dBm/3 kHz)	Limit (dBm/3 kHz)	Pass / Fail
1	2412	-10.18	8	Pass
6	2437	-4.62	8	Pass
11	2462	-11.00	8	Pass

802.11n (HT40)

Channel	Frequency (MHz)	PSD (dBm/3 kHz)	Limit (dBm/3 kHz)	Pass / Fail
3	2422	-15.34	8	Pass
6	2437	-12.84	8	Pass
9	2452	-17.66	8	Pass

Spectrum Plot of Worst Value

802.11b

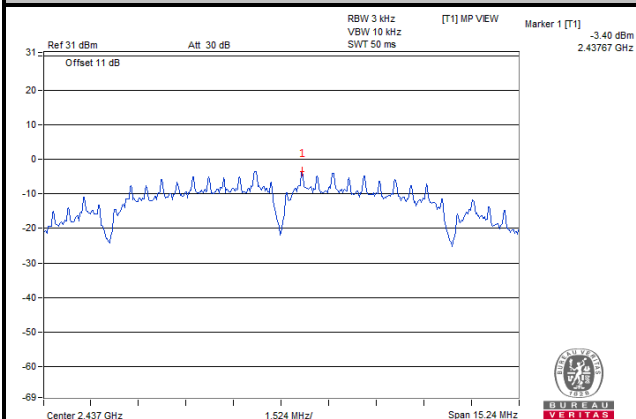

802.11g

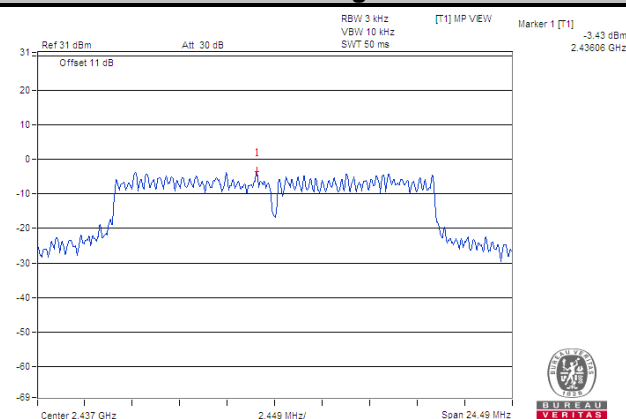

802.11n (HT20)

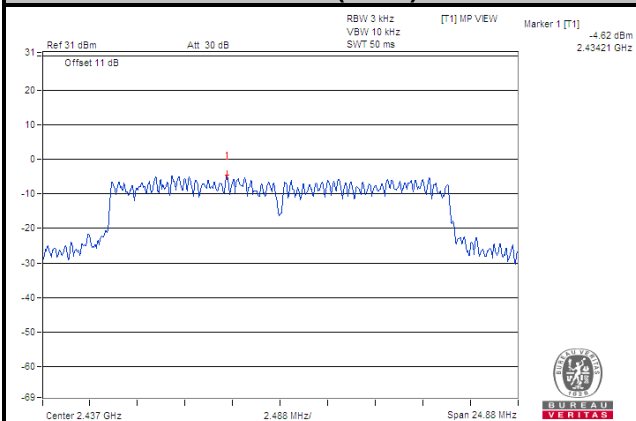

802.11n (HT40)

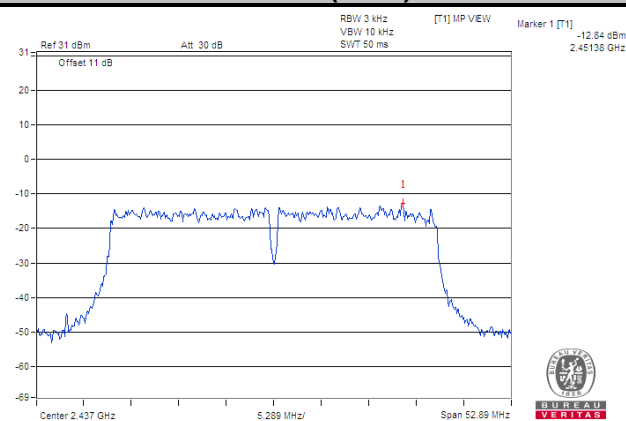

4.7 Conducted Out of Band Emission Measurement

4.7.1 Limits of Conducted Out of Band Emission Measurement

Below -20 dB of the highest emission level of operating band (in 100 kHz Resolution Bandwidth).

4.7.2 Test Setup

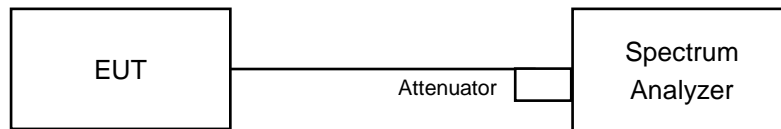

4.7.3 Test Instruments

Refer to section 4.1.2 to get information of above instrument.

4.7.4 Test Procedure

MEASUREMENT PROCEDURE REF

1. Set the RBW = 100 kHz.
2. Set the VBW \geq 300 kHz.
3. Detector = peak.
4. Sweep time = auto couple.
5. Trace mode = max hold.
6. Allow trace to fully stabilize.
7. Use the peak marker function to determine the maximum power level in any 100 kHz band segment within the fundamental EBW.

MEASUREMENT PROCEDURE OOB

1. Set RBW = 100 kHz.
2. Set VBW \geq 300 kHz.
3. Detector = peak.
4. Sweep = auto couple.
5. Trace Mode = max hold.
6. Allow trace to fully stabilize.
7. Use the peak marker function to determine the maximum amplitude level.

4.7.5 Deviation from Test Standard

No deviation.

4.7.6 EUT Operating Condition

The software provided by client to enable the EUT under transmission condition continuously at lowest, middle and highest channel frequencies individually.

4.7.7 Test Results

The spectrum plots are attached on the following images. D1 line indicates the highest level, and D2 line indicates the 20 dB offset below D1. It shows compliance with the requirement.

802.11b

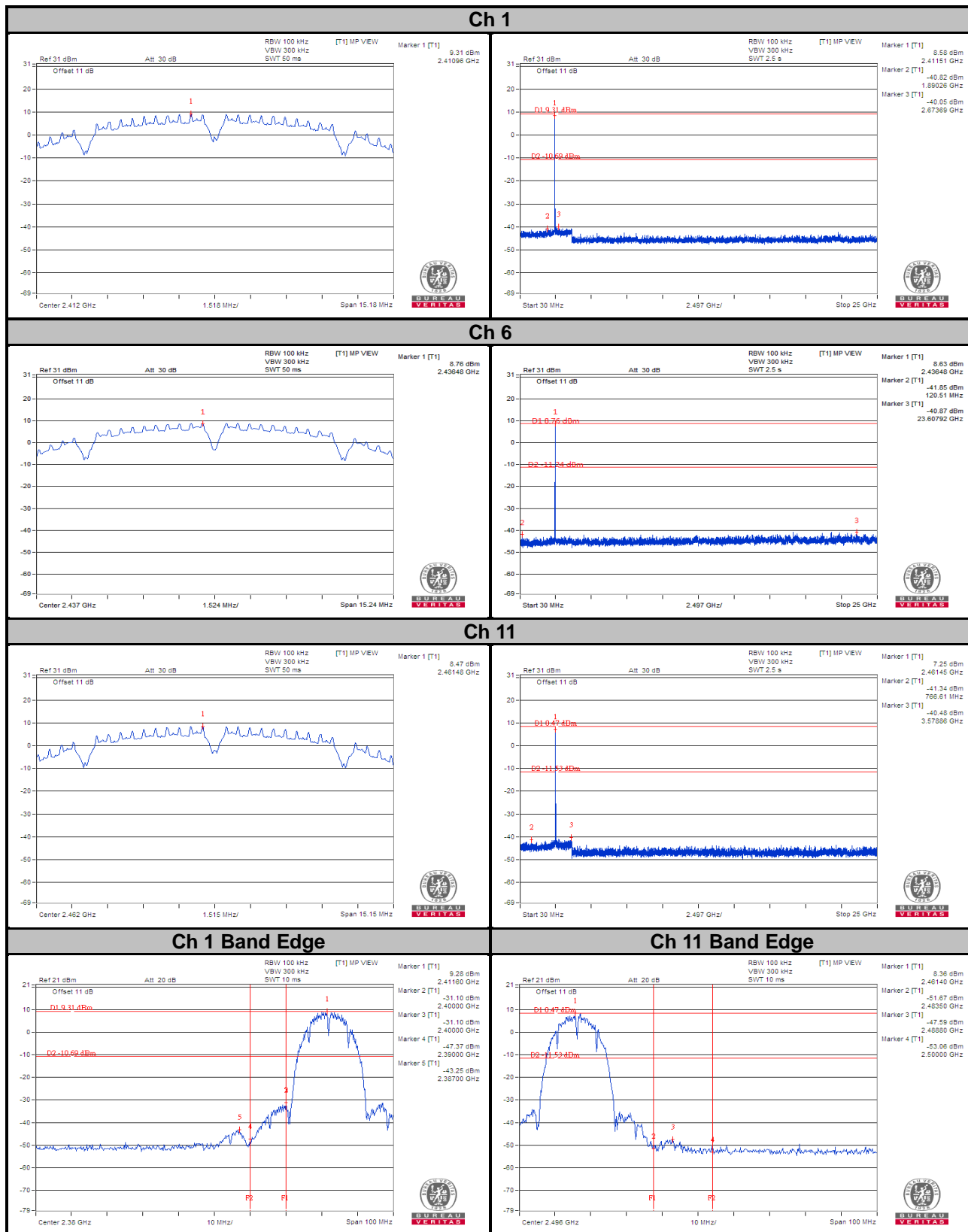

802.11g

Ch 1

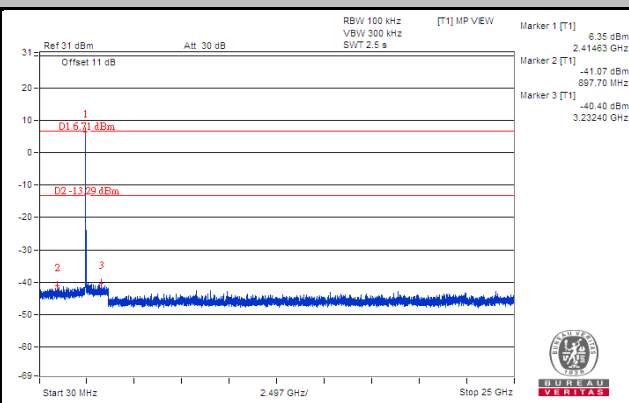
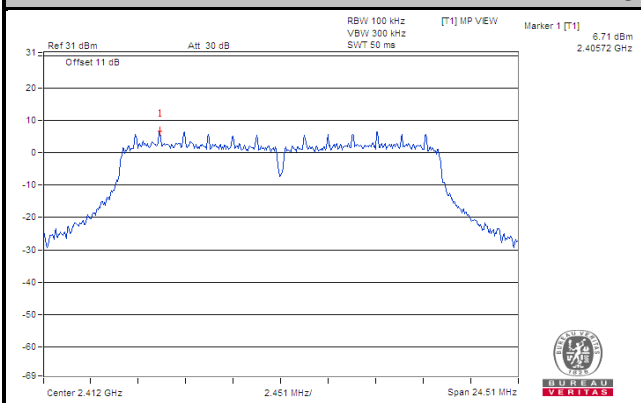

Ch 6

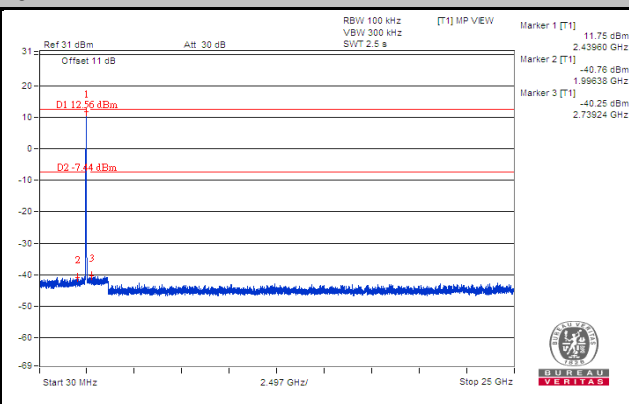
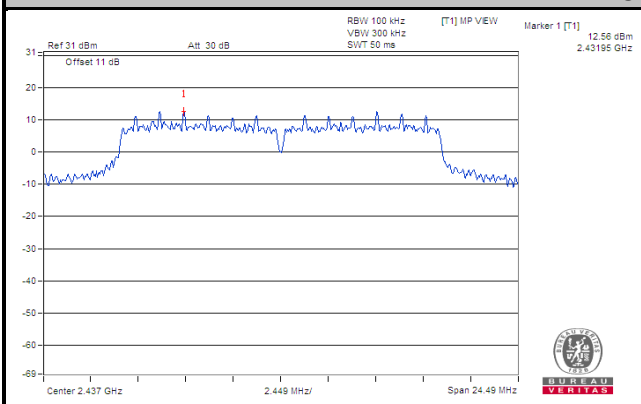

Ch 11

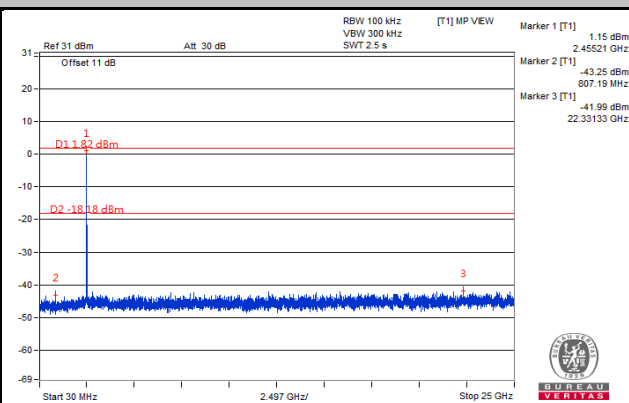
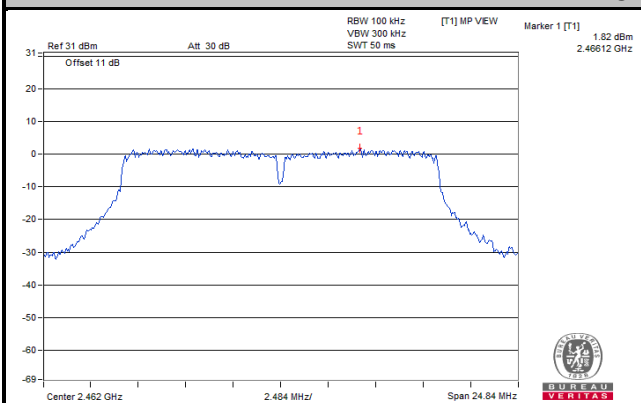

Ch 1 Band Edge

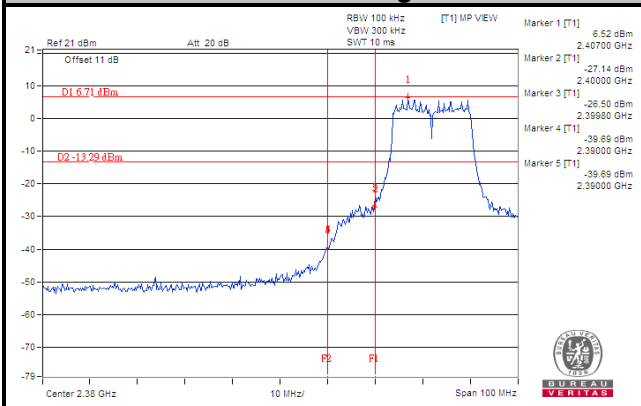

Ch 11 Band Edge

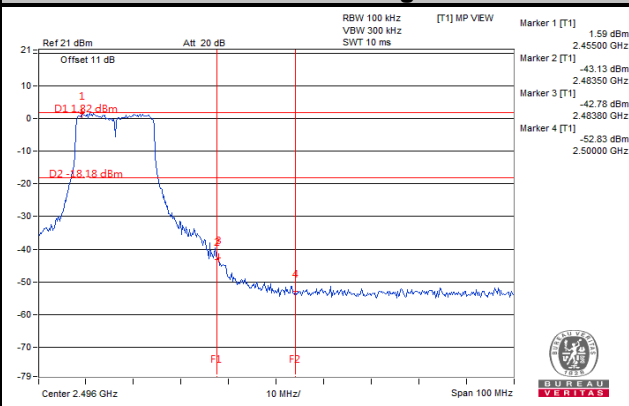

802.11n (HT20)

Ch 1

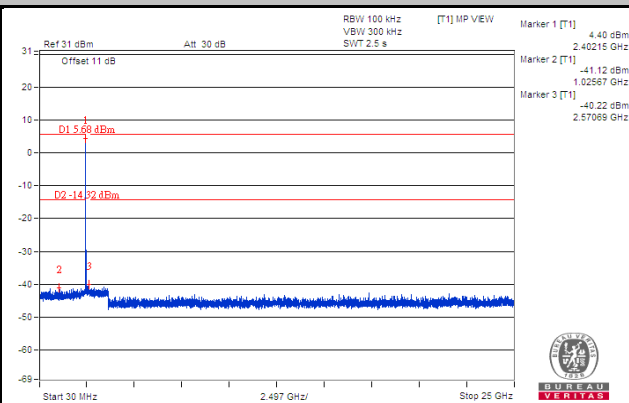
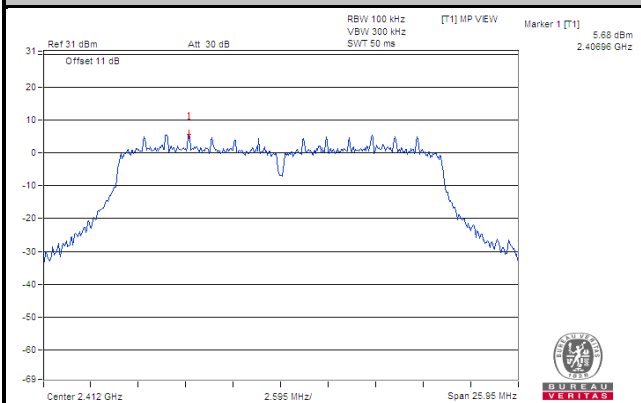

Ch 6

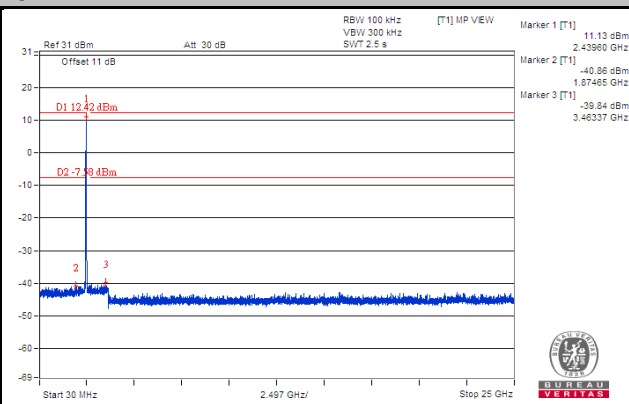
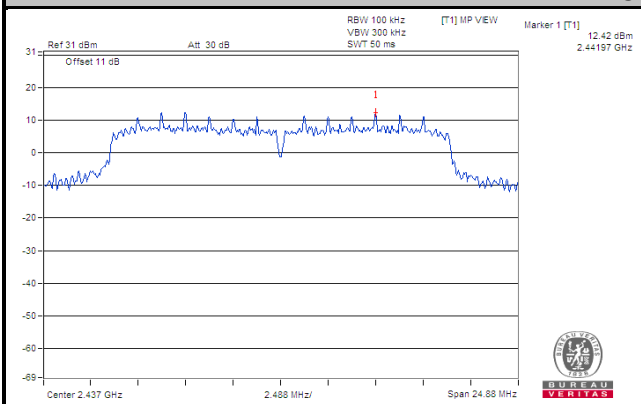

Ch 11

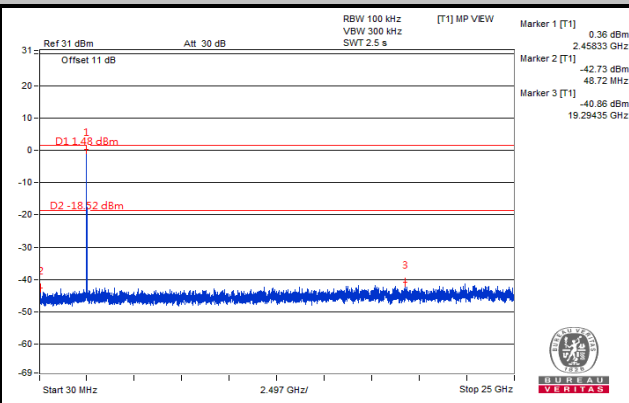
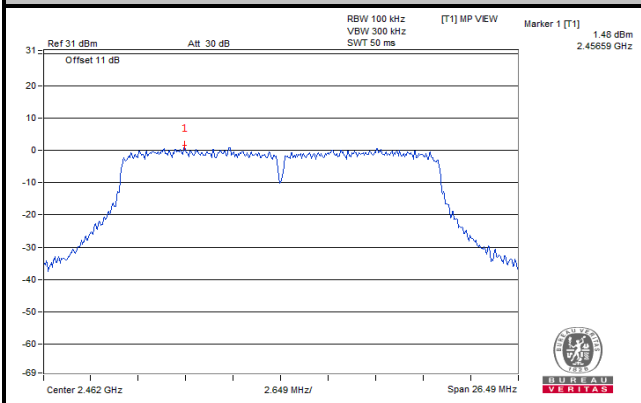

Ch 1 Band Edge

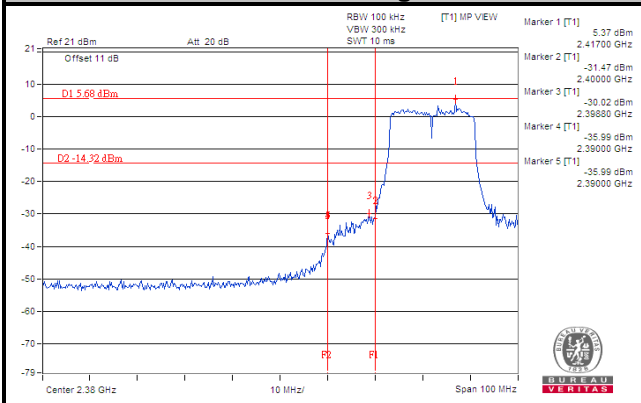

Ch 11 Band Edge

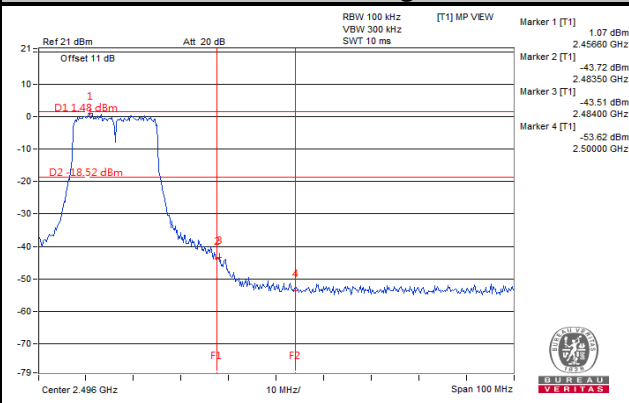

802.11n (HT40)

Ch 3

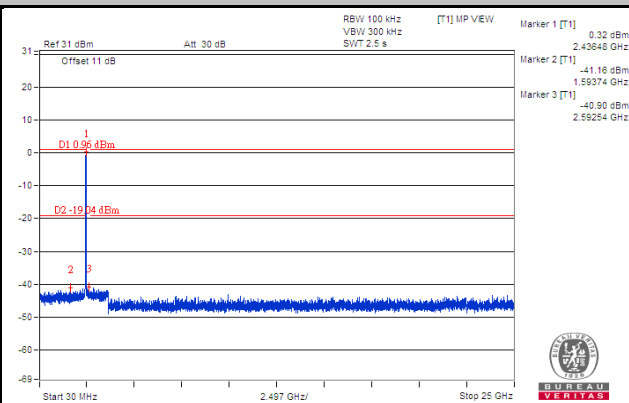
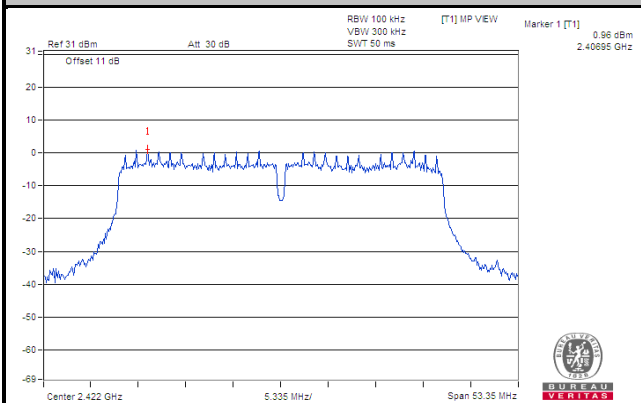

Ch 6

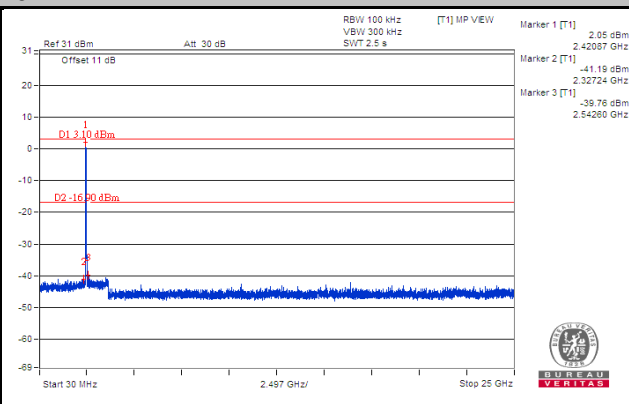
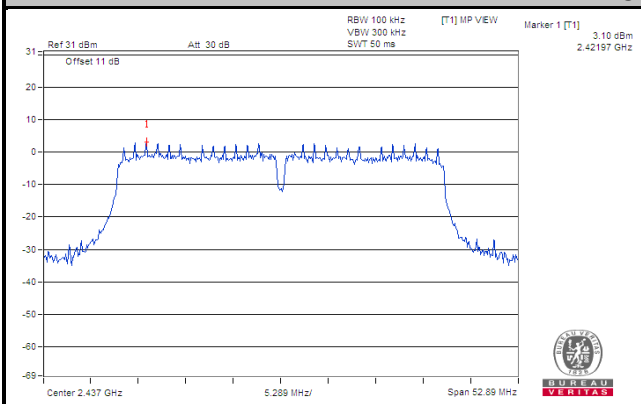

Ch 9

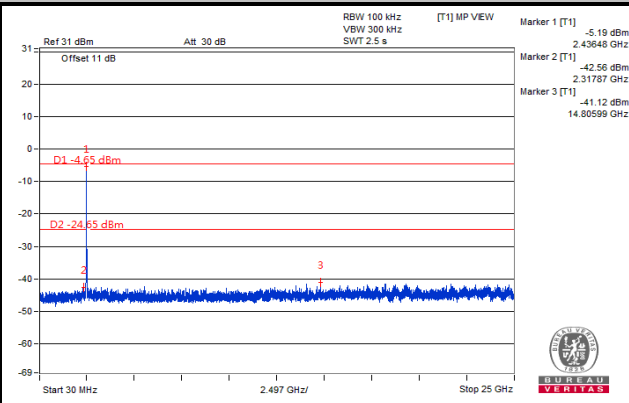
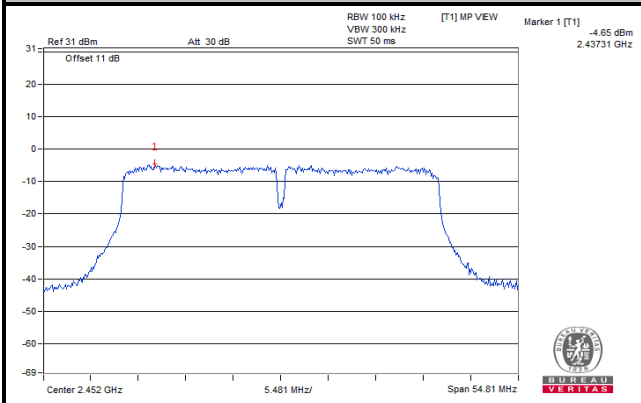

Ch 3 Band Edge

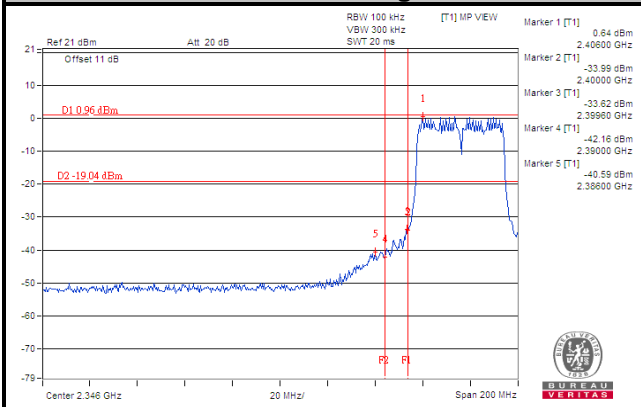

Ch 9 Band Edge

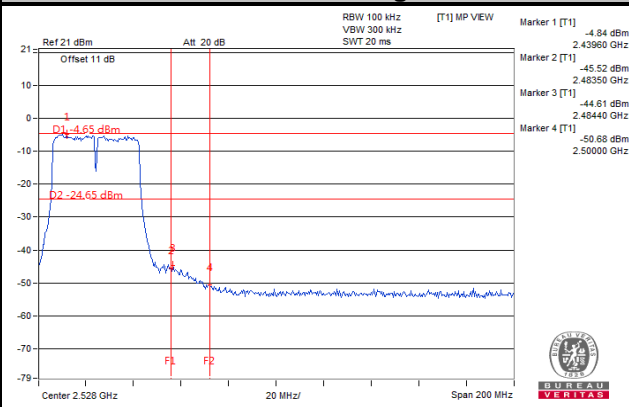

5 Pictures of Test Arrangements

Please refer to the attached file (Test Setup Photo).

Appendix – Information of the Testing Laboratories

We, Bureau Veritas Consumer Products Services (H.K.) Ltd., Taoyuan Branch, were founded in 1988 to provide our best service in EMC, Radio, Telecom and Safety consultation. Our laboratories are FCC recognized accredited test firms and accredited according to ISO/IEC 17025.

If you have any comments, please feel free to contact us at the following:

Lin Kou EMC/RF Lab

Tel: 886-2-26052180

Fax: 886-2-26051924

Hsin Chu EMC/RF/Telecom Lab

Tel: 886-3-6668565

Fax: 886-3-6668323

Hwa Ya EMC/RF/Safety Lab

Tel: 886-3-3183232

Fax: 886-3-3270892

Email: service.adt@tw.bureauveritas.com

Web Site: www.bureauveritas-adt.com

The address and road map of all our labs can be found in our web site also.

--- END ---