





**DATE: 17 December 2019**

**I.T.L. (PRODUCT TESTING) LTD.  
FCC Radio Test Report  
for  
Orcam Technologies Ltd.**

**Equipment under test:  
Portable, Pocket- Sized Smart Pen  
Scanner**

**Orcam Read**

Tested by:   
M. Zohar

Approved by:   
D. Shidlow

This report must not be reproduced, except in full, without the written permission of I.T.L. (Product Testing) Ltd.  
This report relates only to items tested.





# TABLE OF CONTENTS

<b>1.</b>	<b>GENERAL INFORMATION</b>	<b>5</b>
1.1	Administrative Information	5
1.2	List of Accreditations	6
1.3	Product Description	7
1.4	Test Methodology	7
1.5	Test Facility	7
1.6	Measurement Uncertainty	8
<b>2.</b>	<b>SYSTEM TEST CONFIGURATION</b>	<b>9</b>
2.1	Justification	9
2.2	EUT Exercise Software	10
2.3	Special Accessories	10
2.4	Equipment Modifications	10
2.5	Configuration of Tested System	10
<b>3.</b>	<b>CONDUCTED &amp; RADIATED MEASUREMENT TEST SET-UP PHOTOS</b>	<b>12</b>
<b>4.</b>	<b>CONDUCTED EMISSION FROM AC MAINS</b>	<b>16</b>
4.1	Test Specification	16
4.2	Test Procedure	16
4.3	Test Limit	16
4.4	Test Results	17
4.5	Test Equipment Used; Conducted Emission from AC Mains	22
<b>5.</b>	<b>6 DB MINIMUM BANDWIDTH</b>	<b>23</b>
5.1	Test Specification	23
5.2	Test Procedure	23
5.3	Test Limit	23
5.4	Test Results	24
5.5	Test Equipment Used; 6dB Bandwidth	27
<b>6.</b>	<b>MAXIMUM CONDUCTED OUTPUT POWER</b>	<b>28</b>
6.1	Test Specification	28
6.2	Test Procedure	28
6.3	Test Limit	28
6.4	Test Results	28
6.5	Test Equipment Used; Maximum Peak Power Output	31
<b>7.</b>	<b>BAND EDGE SPECTRUM</b>	<b>32</b>
7.1	Test Specification	32
7.2	Test Procedure	32
7.3	Test Limit	32
7.4	Test Results	33
7.5	Test Equipment Used; Band Edge	39
<b>8.</b>	<b>TRANSMITTED POWER DENSITY</b>	<b>40</b>
8.1	Test Specification	40
8.2	Test Procedure	40
8.3	Test Limit	40
8.4	Test Results	41
8.5	Test Equipment Used; Transmitted Power Density	45
<b>9.</b>	<b>OCCUPIED BANDWIDTH</b>	<b>46</b>
9.1	Test Specification	46
9.2	Test Procedure	46
9.3	Test Limit	46
9.4	Test Results	47
9.5	Test Equipment Used; Occupied Bandwidth	51



<b>10.</b>	<b>EMISSIONS IN NON-RESTRICTED FREQUENCY BANDS</b>	<b>52</b>
10.1	Test Specification	52
10.2	Test Procedure	52
10.3	Test Limit	52
10.4	Test Results	52
10.5	Test Instrumentation Used, Emissions in Non Restricted Frequency Bands	58
<b>11.</b>	<b>EMISSIONS IN RESTRICTED FREQUENCY BANDS</b>	<b>59</b>
11.1	Test Specification	59
11.2	Test Procedure	59
11.3	Test Limit	60
11.4	Test Results for BLE	60
11.5	Test Results for WiFi	61
11.6	Test Instrumentation Used; Emissions in Restricted Frequency Bands	67
<b>12.</b>	<b>ANTENNA GAIN/INFORMATION</b>	<b>68</b>
<b>13.</b>	<b>R.F EXPOSURE/SAFETY</b>	<b>69</b>
<b>14.</b>	<b>APPENDIX A - CORRECTION FACTORS</b>	<b>71</b>
14.1	Correction factors for RF OATS Cable 35m ITL #1911	71
14.2	Correction factor for RF CABLE for Semi Anechoic Chamber	72
14.3	Correction factors for Active Loop Antenna ITL # 1075:	73
14.4	Correction factors for biconical antenna ITL # 1356	74
14.5	Correction factors for log periodic antenna ITL # 1349	75
14.6	Correction factors for Double –Ridged Waveguide Horn ANTENNA ITL # 1352	76
14.7	Correction factors for Horn Antenna ITL #:1353	77



# 1. General Information

## 1.1 Administrative Information

Manufacturer: Orcam Technologies Ltd.

Manufacturer's Address: 3 Kiryat Mada St.  
P.O. Box 45157  
Jerusalem, 9777603, Israel  
Tel: +972-2-591-7805  
Fax: +972-2-586-0121

Manufacturer's Representative: Ram Ben-Yehuda

Equipment Under Test (E.U.T): Portable, Pocket- Sized Smart Pen Scanner

Equipment PMN: Orcam Read

Equipment Serial No.: 19350053

Date of Receipt of E.U.T: November 10, 2019

Start of Test: November 10, 2019

End of Test: November 28, 2019

Test Laboratory Location: I.T.L (Product Testing) Ltd.  
1 Batsheva St.,  
Lod  
ISRAEL 7120101

Test Specifications: FCC Part 15, Subpart C, Section 15.247



## **1.2 List of Accreditations**

The EMC laboratory of I.T.L. is accredited by the following bodies:

1. The American Association for Laboratory Accreditation (A2LA) (U.S.A.), Certificate No. 1152.01.
2. The Federal Communications Commission (FCC) (U.S.A.), FCC Designation No. IL1005.
3. The Israel Ministry of the Environment (Israel), Registration No. 1104/01.
4. Department of Innovation, Science and Economic Development (ISED) Canada, CAB identifier: IL1002

I.T.L. Product Testing Ltd. is accredited by the American Association for Laboratory Accreditation (A2LA) and the results shown in this test report have been determined in accordance with I.T.L.'s terms of accreditation unless stated otherwise in the report.



### 1.3 **Product Description**

Orcam Read is a portable, pocket- sized smart pen scanner.  
Orcam Read provides the most advanced solution for those who suffer from reading difficulties such as dyslexia.

Working voltage	5.0VDC Rechargeable battery
Mode of operation	Transceiver
Modulations	For Wi-Fi/g: OFDM(BPSK,QPSK,16QAM ,64QAM) For Wi-Fi/n: OFDM(BPSK,QPSK,16QAM ,64QAM) For BLE: GFSK
Assigned Frequency Range	2400.0-2483.5MHz
Operating Frequency Range	For Wi-Fi/g/n: 2412.0-2462.0MHz For BLE: 2402.0-2480.0MHz
Conducted power	~ 15dBm
Antenna Gain	-0.87dBi
Modulation BW	For Wi-Fi/g/n: 20MHz For BLE: 2MHz
Bit rate (Mbit/s)	For Wi-Fi/g: 6, 9, 12, 18, 24, 36, 48, 54 For Wi-Fi/n: 6.5,13,19.5,26,39,52,58.5,65 For BLE: 1,2,3

### 1.4 **Test Methodology**

Both conducted and radiated testing was performed according to the procedures in KDB 558074 D01 v05 r02 and ANSI C63.10: 2013. Radiated testing was performed at an antenna to EUT distance of 3 meters.

### 1.5 **Test Facility**

Emissions tests were performed at I.T.L.'s testing facility in Lod, Israel. I.T.L.'s EMC Laboratory is accredited by A2LA, certificate No. 1152.01 and its FCC Designation Number is IL1005.



## 1.6 **Measurement Uncertainty**

### **Conducted Emission**

Conducted Emission (CISPR 11, EN 55011, CISPR 22, EN 55022, ANSI C63.4)

0.15 – 30 MHz:

Expanded Uncertainty (95% Confidence, K=2):

± 3.44 dB

### **Radiated Emission**

Radiated Emission (CISPR 11, EN 55011, CISPR 22, EN 55022, ANSI C63.4) for open site:

30-1000MHz:

Expanded Uncertainty (95% Confidence, K=2):

± 4.96 dB

1 GHz to 6 GHz

Expanded Uncertainty (95% Confidence, K=2):

±5.19 dB

>6 GHz

Expanded Uncertainty (95% Confidence, K=2):

±5.51 dB



## 2. System Test Configuration

### 2.1 Justification

1. The E.U.T contains 2 optional transceivers: IEEE 802.15.1 standard (BLE) or IEEE 802.11g/n standard (Wi-Fi/g/n) with only 20MHz CBW.
2. For BLE - The unit was evaluated while transmitting at the low channel (2402MHz), the mid channel (2440MHz) and the high channel (2480MHz).  
For Wi-Fi /g/n - The unit was evaluated while transmitting at the low channel (2412MHz), the mid channel (2437MHz) and the high channel (2462MHz).
3. The evaluation was performed while the E.U.T was connected to an AC/DC power supply in charge mode as the “worst case”.
4. Conducted emission tests were performed with the E.U.T. antenna terminal connected by a RF cable to the Spectrum Analyzer through a 30dB external attenuator.
5. Final radiated emission for Wi-Fi g/n modes tests were performed using the lowest and highest bit rates for each different protocol type. The bit rates for each protocol are shown in the table below:

Protocol Type	“Worst Case” Bit Rate
Wi-Fi/g	6,54 Mbit/s
Wi-Fi/n	6.5,65 Mbit/s (MCS0,MCS7)

7. Final radiated emission tests was performed after exploratory emission testing that was performed in 3 orthogonal polarities to determine the “worst case” radiation. According to below results the worst case was at the X axis

Orientation	Frequency	2 <sup>nd</sup> Harmonic	3 <sup>rd</sup> Harmonic	Band Edge
	(MHz)	(dBuV/m)	(dBuV/m)	(dBuV/m)
X axis	2412.0	47.4	55.2	61.2
	2437.0	48.0	55.9	-
	2462.0	47.1	55.6	73.8
Y axis	2412.0	47.0	53.8	59.8
	2437.0	47.1	54.2	-
	2462.0	46.9	54.0	73.5
Z axis	2412.0	45.2	47.6	57.4
	2437.0	45.1	48.0-	-
	2462.0	45.5	50.0	71.3

Figure 1. Screening Results

**2.2 EUT Exercise Software**

No special exercise software was used.

**2.3 Special Accessories**

Equipment	Manufacturer	Part Number	Serial Number
AC/DC power supply	Shenzhen Super Eagle Technology Co. Ltd	CH06-050200-EU	N/A

**2.4 Equipment Modifications**

Initially the E.U.T failed in the high band edge testing at the high channel (2462MHz).

The customer reduced the fundamental power until the E.U.T passed the specified limit. Power was reduced by using the value code 8 for the power configuration script.

**2.5 Configuration of Tested System**

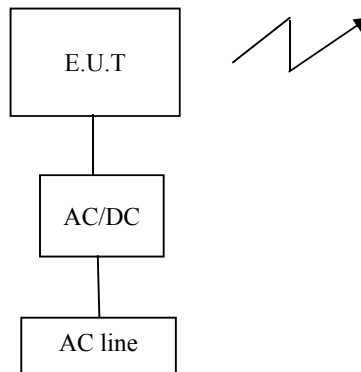

**Figure 2. Configuration of Tested System – Radiated**

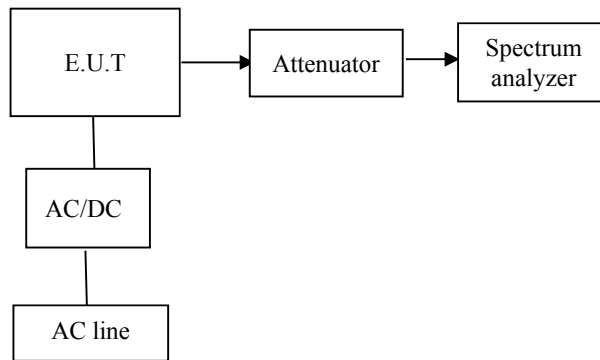

**Figure 3. Configuration of Tested System - Conducted**



### 3. Conducted & Radiated Measurement Test Set-Up Photos



Figure 4. Conducted Emission Test from AC Line Test

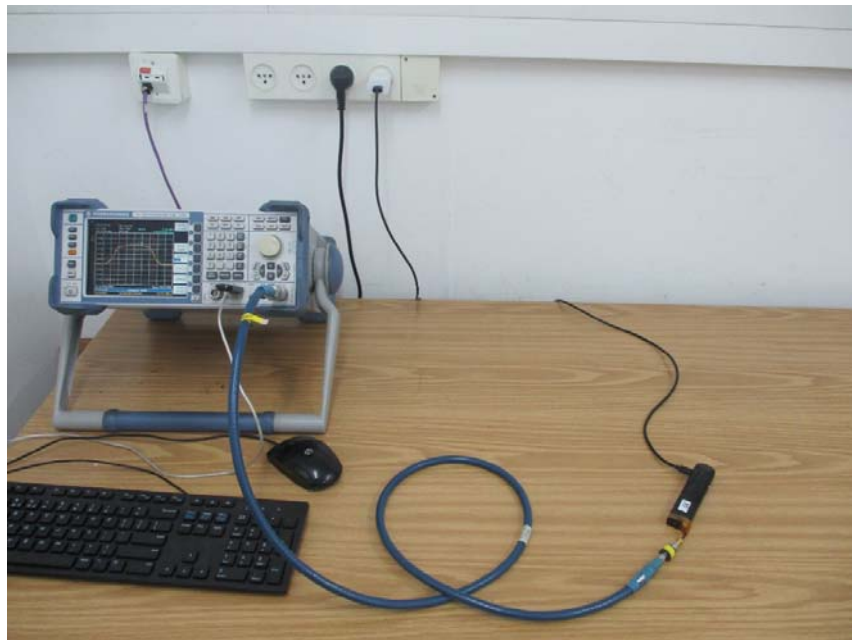

Figure 5. Conducted Emission Test



**Figure 6. Radiated Emission Test, 0.009-30MHz**



**Figure 7. Radiated Emission Test, 30-200MHz**



**Figure 8. Radiated Emission Test, 200-1000MHz**



**Figure 9. Radiated Emission Test, 1-18GHz**



**Figure 10. Radiated Emission Test, 18-26.5GHz**

## 4. Conducted Emission From AC Mains

### 4.1 Test Specification

FCC Part 15, Subpart C, Section 15.207

### 4.2 Test Procedure

(Temperature (20°C)/ Humidity (45%RH))

The E.U.T operation mode and test setup are as described in Section 2 of this report. In order to minimize background noise interference, the conducted emission testing was performed inside a shielded room, with the E.U.T placed on a 0.8 meter high wooden table, 0.4 meter from the room's vertical wall. In the case of a floor-standing E.U.T., it was placed on the horizontal ground plane.

The E.U.T was powered from 115 V AC / 60 Hz via 50 Ohm / 50  $\mu$ Hn Line Impedance Stabilization Network (LISN) on the phase and neutral lines. The LISN's were grounded to the shielded room ground plane (floor), and were kept at least 0.8 meters from the nearest boundary of the E.U.T.

The center of the E.U.T.'s AC cable was folded back and forth, in order to form a bundle less than 0.40 meters and a total cable length of 1 meter.

The effect of varying the position of the cables was investigated to find the configuration that produces maximum emission. The configurations tested are shown in the photographs, *Figure 4* and *Figure 5*.

The emission voltages at the LISN's outputs were measured using a computerized receiver, complying with CISPR 16 requirements. The specification limits are loaded to the receiver and are displayed on the receiver's spectrum display.

The E.U.T was evaluated in TX operation mode (WI-FI/g 6Mbps)

A frequency scan between 0.15 and 30 MHz was performed at 9 kHz I.F. band width, using peak detection.

The spectral components having the highest level on each line were measured using a quasi-peak and average detector.

### 4.3 Test Limit

Frequency of emission (MHz)	Conducted limit (dB $\mu$ V)	
	Quasi-peak	Average
0.15-0.5	66 to 56*	56 to 46*
0.5-5	56	46
5-30	60	50

\* Decreases with the logarithm of the frequency.





#### 4.4 **Test Results**

JUDGEMENT: Passed by 4.94 dB

The margin between the emission levels and the specification limit is, in the worst case, -19.06 dB for the phase line at 0.578 MHz and -4.94 dB at 0.578 MHz for the neutral line.

The EUT met the F.C.C. Part 15, Subpart C specification requirements.

The details of the highest emissions are given in *Figure 11* to ***Error! Reference source not found.***



## Conducted Emission

E.U.T Description      Portable, Pocket- Sized Smart Pen Scanner  
Type                      Orcam Read  
Serial Number:         19350053

Specification:         FCC Part 15, Subpart C  
Lead:                    Phase  
Detectors: :            Peak, Quasi-peak, Average  
Power Operation       AC/DC power supply

EDIT PEAK LIST (Final Measurement Results)			
TRACE	FREQUENCY	LEVEL dBμV	DELTA LIMIT dB
Trace1:	CE22BQP		
Trace2:	CE22BAP		
Trace3:	---		
1 Quasi Peak	182 kHz	39.89	-24.49
2 Average	242 kHz	19.49	-32.53
1 Quasi Peak	402 kHz	37.42	-20.38
2 Average	426 kHz	24.20	-23.12
2 Average	578 kHz	26.93	-19.06
1 Quasi Peak	582 kHz	35.75	-20.24
1 Quasi Peak	886 kHz	33.52	-22.47
2 Average	1.042 MHz	25.76	-20.23
1 Quasi Peak	1.382 MHz	21.92	-34.07
2 Average	1.582 MHz	18.49	-27.50
1 Quasi Peak	2.51 MHz	27.88	-28.11
2 Average	2.51 MHz	18.59	-27.41
1 Quasi Peak	4.01 MHz	22.23	-33.76
2 Average	4.45 MHz	12.22	-33.77
2 Average	9.126 MHz	17.23	-32.76
1 Quasi Peak	9.166 MHz	27.16	-32.83
2 Average	13.418 MHz	21.10	-28.89
1 Quasi Peak	17.378 MHz	26.79	-33.20
1 Quasi Peak	17.694 MHz	30.71	-29.28
2 Average	17.694 MHz	24.80	-25.19

Date: 24.NOV.2019 16:03:45

**Figure 11. Detectors: Peak, Quasi-peak, Average**

*Note: QP Delta/Av Delta refers to the test results obtained minus specified requirement; thus a positive number indicates failure, and a negative result indicates that the product passes the test.*



# Conducted Emission

E.U.T Description     Portable, Pocket- Sized Smart Pen Scanner  
Type                     Orcam Read  
Serial Number:         19350053

Specification:         FCC Part 15, Subpart C  
Lead:                    Phase  
Detectors:             Peak, Quasi-peak, Average  
Power Operation       AC/DC power supply

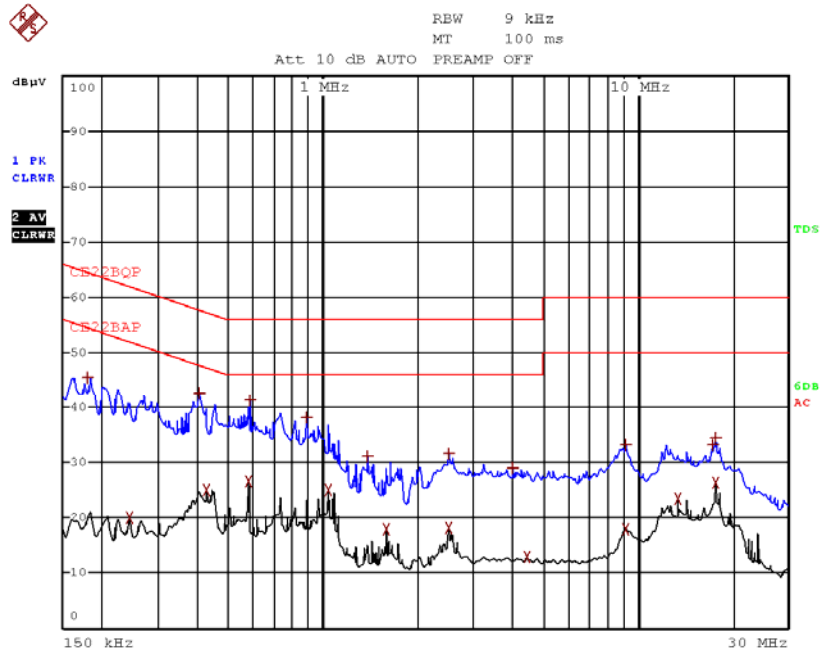

Date: 24.NOV.2019 15:58:24

Figure 12. Detectors: Peak, Quasi-peak, Average



## Conducted Emission

E.U.T Description      Portable, Pocket- Sized Smart Pen Scanner  
 Type                      Orcam Read  
 Serial Number:         19350053

Specification:         FCC Part 15, Subpart C  
 Lead:                     Neutral  
 Detectors:              Peak, Quasi-peak, Average  
 Power Operation       AC/DC power supply

EDIT PEAK LIST (Final Measurement Results)			
Trace1:	CE22BQP		
Trace2:	CE22BAP		
Trace3:	---		
TRACE	FREQUENCY	LEVEL dB $\mu$ V	DELTA LIMIT dB
2 Average	194 kHz	32.55	-21.30
1 Quasi Peak	198 kHz	38.07	-25.62
1 Quasi Peak	426 kHz	39.94	-17.38
2 Average	426 kHz	32.05	-15.27
1 Quasi Peak	578 kHz	50.75	-5.24
2 Average	578 kHz	41.05	-4.94
1 Quasi Peak	1.042 MHz	50.33	-5.66
2 Average	1.042 MHz	34.78	-11.21
1 Quasi Peak	1.582 MHz	41.55	-14.44
2 Average	1.582 MHz	26.15	-19.85
1 Quasi Peak	2.51 MHz	39.40	-16.59
2 Average	2.51 MHz	26.52	-19.47
2 Average	4.014 MHz	14.18	-31.81
1 Quasi Peak	4.03 MHz	23.76	-32.23
2 Average	9.11 MHz	17.92	-32.08
1 Quasi Peak	9.158 MHz	26.48	-33.51
1 Quasi Peak	12.438 MHz	27.70	-32.29
2 Average	13.358 MHz	22.64	-27.35
1 Quasi Peak	17.694 MHz	29.66	-30.33
2 Average	17.694 MHz	24.79	-25.20

Date: 24.NOV.2019 15:52:36

**Figure 13. Detectors: Peak, Quasi-peak, Average**

*Note: QP Delta/Av Delta refers to the test results obtained minus specified requirement; thus a positive number indicates failure, and a negative result indicates that the product passes the test.*



# Conducted Emission

E.U.T Description     Portable, Pocket- Sized Smart Pen Scanner  
Type                     Orcam Read  
Serial Number:        19350053

Specification:        FCC Part 15, Subpart C  
Lead:                   Neutral  
Detectors:             Peak, Quasi-peak, Average  
Power Operation      AC/DC power supply

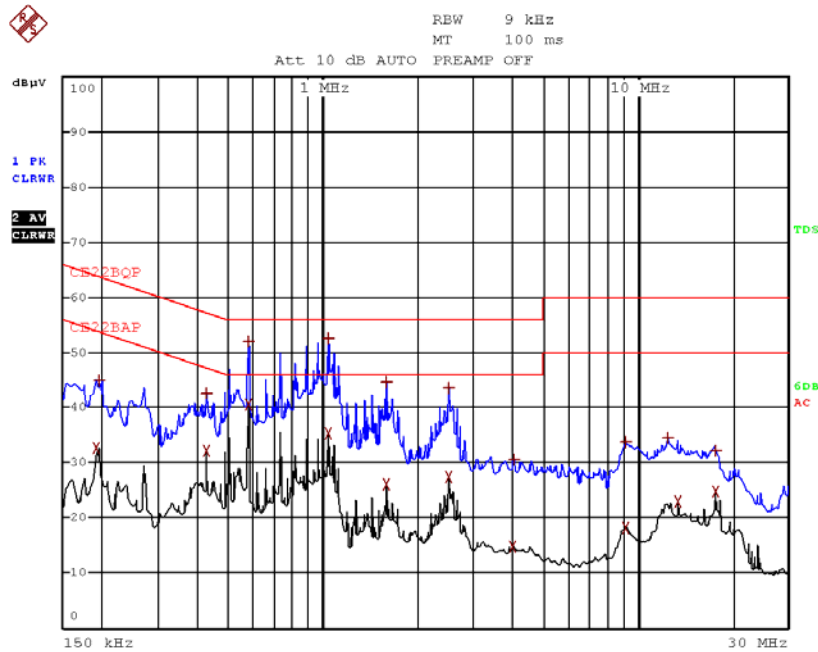

Date: 24.NOV.2019 15:50:37

Figure 14 Detectors: Peak, Quasi-peak, Average



#### 4.5 Test Equipment Used; Conducted Emission from AC Mains

<b>Instrument</b>	<b>Manufacturer</b>	<b>Model</b>	<b>Serial No.</b>	<b>Last Calibration Date</b>	<b>Next Calibration Due</b>
LISN	Fischer	FCC-LISN-25A	127	September 8, 2019	September 30, 2020
Transient Limiter	HP	11947A	3107A03041	September 16, 2019	September 30, 2020
EMI Receiver	Rohde & Schwarz	ESCI7	100724	February 27, 2019	February 28, 2020
Cable CE Chamber 3M + 3M	Testline 18 + RJ214	11556	-	March 31, 2019	March 31, 2020

Figure 15 Test Equipment Used



## 5. 6 dB Minimum Bandwidth

### 5.1 *Test Specification*

FCC Part 15, Subpart C, Section 247(a)(2)

### 5.2 *Test Procedure*

(Temperature (20°C)/ Humidity (52%RH))

The E.U.T operation mode and test set-up are as described in Section 2 of this report.

The E.U.T. antenna terminal was connected to the Spectrum Analyzer through an external attenuator and an appropriate coaxial cable. Special attention was taken to prevent Spectrum Analyzer RF input overload.

The spectrum bandwidth of the E.U.T. at the point of 6 dB below maximum peak power was measured and recorded. The RBW was set to 100 kHz.

### 5.3 *Test Limit*

Systems using digital modulation techniques may operate in the 902-928 MHz, 2400-2483.5 MHz, and 5725-5850 MHz bands. The minimum 6 dB bandwidth shall be at least 500 kHz.

#### 5.4 Test Results

Protocol Type	Operation Frequency	Reading	Limit
	(MHz)	(kHz)	(kHz)
BLE	2402.0	719.0	>500.0
	2440.0	719.0	>500.0
	2480.0	709.0	>500.0
Wi-fi/g(6Mbit/s)	2412.0	15,729.0	>500.0
	2437.0	16,208.0	>500.0
	2462.0	15,649.0	>500.0
Wi-fi/g(54Mbit/s)	2412.0	15,968.0	>500.0
	2437.0	16,457.0	>500.0
	2462.0	16,208.0	>500.0
Wi-fi/n(6.5Mbit/s)	2412.0	16,926.0	>500.0
	2437.0	16,607.0	>500.0
	2462.0	15,888.0	>500.0
Wi-fi/n(65Mbit/s)	2412.0	17,405.0	>500.0
	2437.0	17,166.0	>500.0
	2462.0	16,926.0	>500.0

**Figure 16 6 dB Minimum Bandwidth**

JUDGEMENT: Passed

For additional information see *Figure 17* to *Figure 31*.



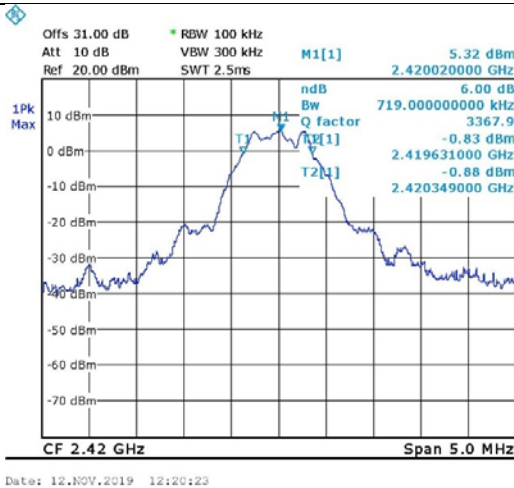

Figure 17. 2402.0 MHz, BLE

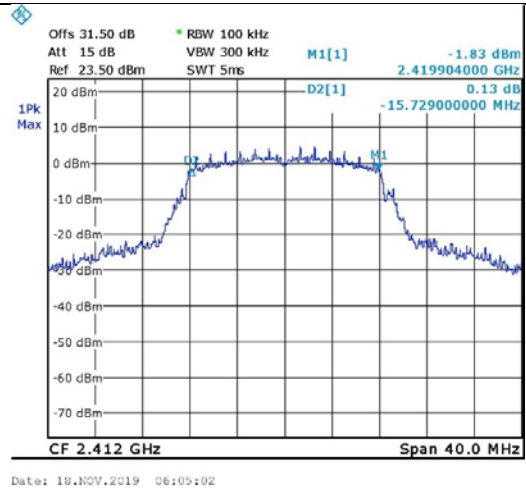

Figure 18. 2412.0 MHz, Wi-fi/g(6Mbit/s)

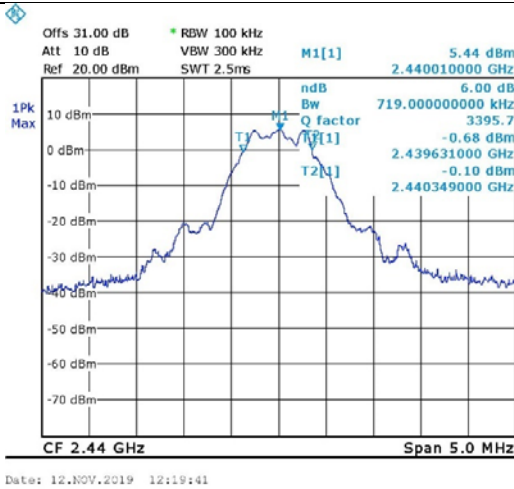

Figure 19. 2440.0 MHz, BLE

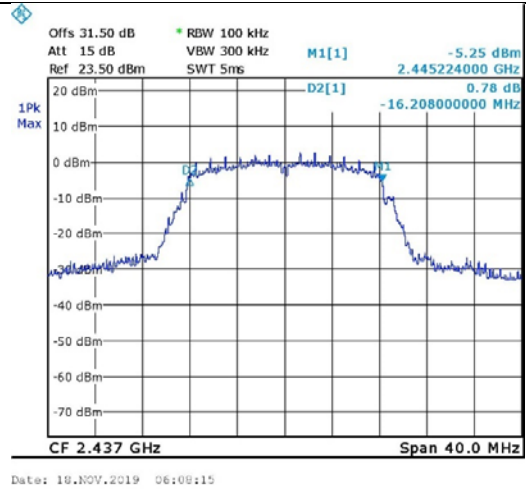

Figure 20. 2437.0 MHz, Wi-fi/g(6Mbit/s)

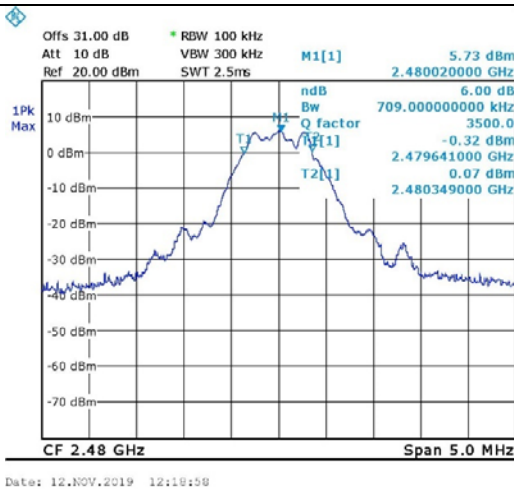

Figure 21. 2480.0 MHz, BLE

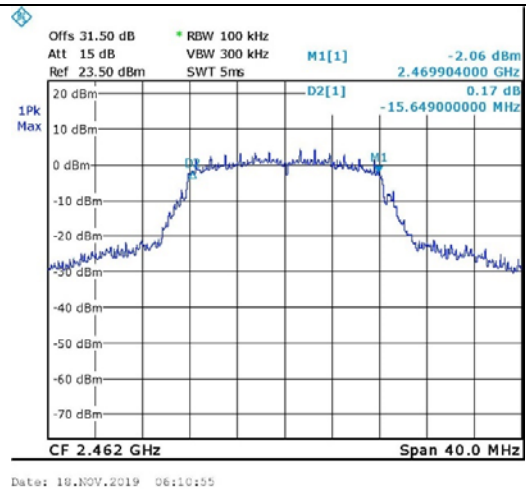

Figure 22. 2462.0 MHz, Wi-fi/g(6Mbit/s)

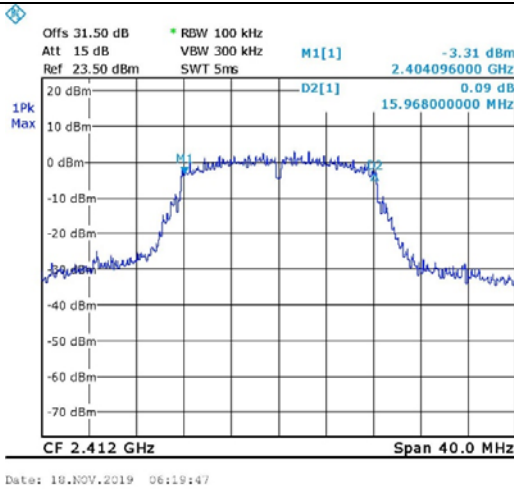

Figure 23. 2412.0 MHz, Wi-fi/g(54Mbit/s)

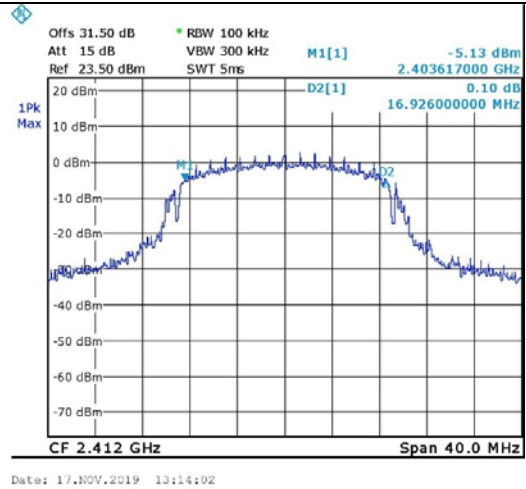

Figure 24. 2412.0 MHz, Wi-fi/n(6.5Mbit/s)

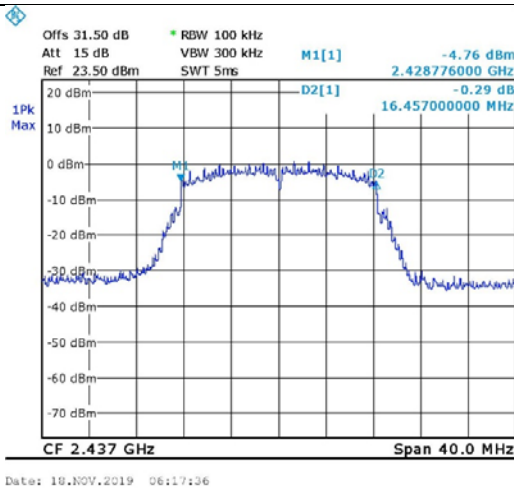

Figure 25. 2437.0 MHz, Wi-fi/g(54Mbit/s)

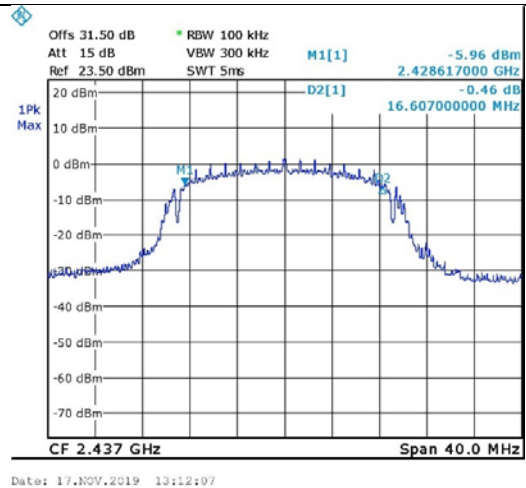

Figure 26. 2437.0 MHz, Wi-fi/n(6.5Mbit/s)

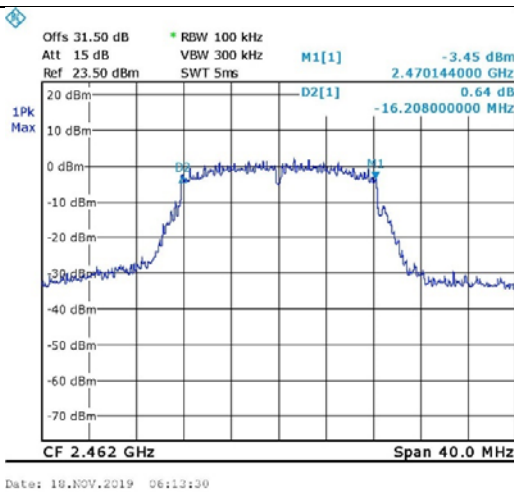

Figure 27. 2462.0 MHz, Wi-fi/g(54Mbit/s)

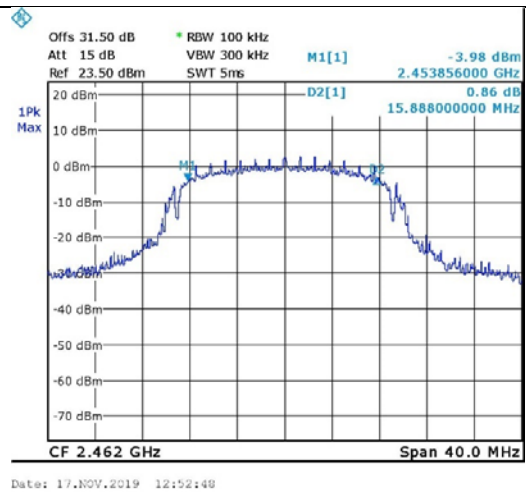

Figure 28. 2462.0 MHz, Wi-fi/n(6.5Mbit/s)

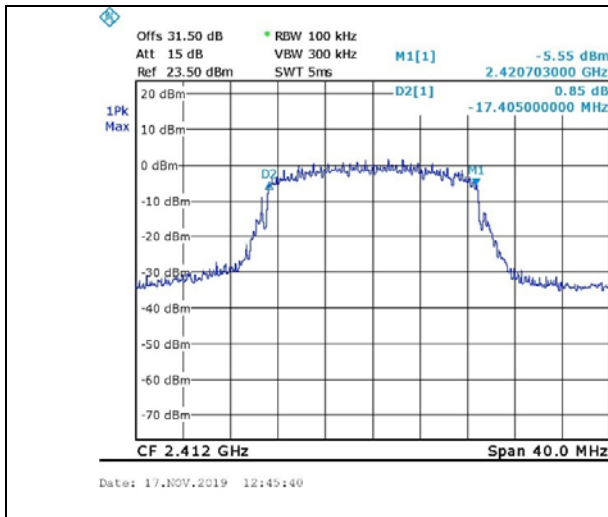

Figure 29. 2412.0 MHz, Wi-fi/n(65Mbit/s)

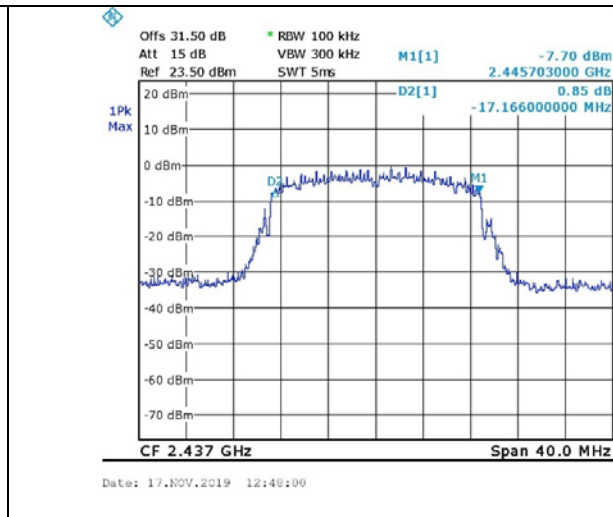

Figure 30. 2437.0 MHz, Wi-fi/n(65Mbit/s)

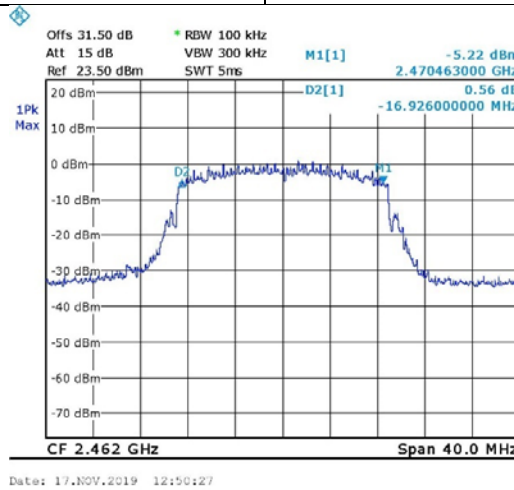

Figure 31. 2462.0 MHz, Wi-fi/n(65Mbit/s)

### 5.5 Test Equipment Used; 6dB Bandwidth

Instrument	Manufacturer	Model	Serial No.	Last Calibration Date	Next Calibration Due
Spectrum Analyzer	R&S	FSL6	100194	March 24, 2019	March 31, 2020
30dB Attenuator	MCL	BW-S30W5	533	December 24, 2018	December 31, 2019
RF Cable	Huber Suner	Sucofelex	27502/4PEA	December 24, 2018	December 31, 2019
RF Cable	Itl 1846				

Figure 32 Test Equipment Used

## 6. Maximum Conducted Output Power

### 6.1 Test Specification

FCC, Part 15, Subpart C, Section 247(b)(3)

### 6.2 Test Procedure

(Temperature (20°C)/ Humidity (58%RH))

The E.U.T operation mode and test set-up are as described in Section 2 of this report.

The E.U.T. antenna terminal was connected to the Spectrum Analyzer through an external attenuator and an appropriate coaxial cable. Special attention was taken to prevent Spectrum Analyzer RF input overload.

### 6.3 Test Limit

The maximum peak conducted output power of the intentional radiator for systems using digital modulation in the 902-928 MHz, 2400-2483.5 MHz, and 5725-5850 MHz bands: 1 Watt.

### 6.4 Test Results

Protocol Type	Operation Frequency	Power	Power	Limit	Margin
	(MHz)	(dBm)	(mW)	(mW)	(mW)
BLE	2402.0	6.7	4.7	1000.0	-995.3
	2440.0	6.5	4.5	1000.0	-995.5
	2480.0	6.8	4.8	1000.0	-995.2
Wi-fi/g(6Mbit/s)	2412.0	15.6	36.3	1000.0	-963.7
	2437.0	13.9	24.5	1000.0	-975.5
	2462.0	14.9	30.9	1000.0	-969.1
Wi-fi/g(54Mbit/s)	2412.0	15.2	33.1	1000.0	-966.9
	2437.0	13.5	22.4	1000.0	-977.6
	2462.0	14.7	29.5	1000.0	-970.5
Wi-fi/n(6.5Mbit/s)	2412.0	14.9	30.9	1000.0	-969.1
	2437.0	13.3	21.3	1000.0	-978.7
	2462.0	14.3	26.9	1000.0	-973.1
Wi-fi/n(65Mbit/s)	2412.0	14.9	30.9	1000.0	-969.1
	2437.0	12.5	17.8	1000.0	-982.2
	2462.0	13.5	22.4	1000.0	-977.6

Figure 33 Maximum Peak Power Output

JUDGEMENT: Passed by 963.7 mW

For additional information see *Figure 34* to *Figure 48*.

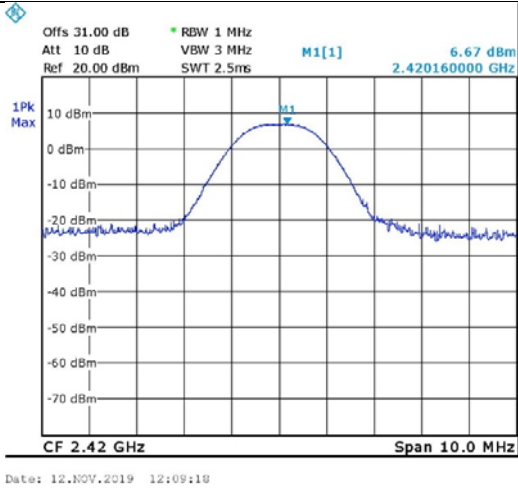

Figure 34. 2402.0 MHz, BLE

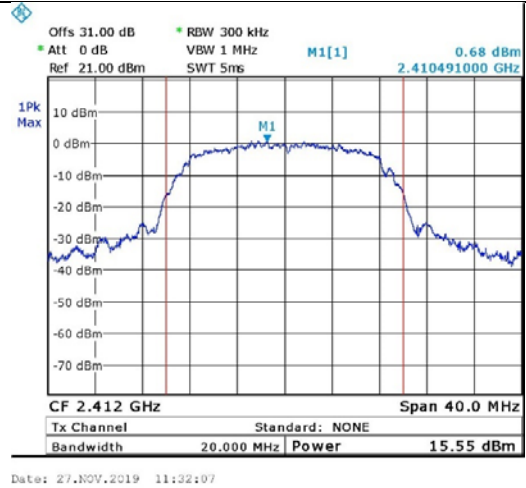

Figure 35. 2412.0 MHz, Wi-fi/g(6Mbit/s)

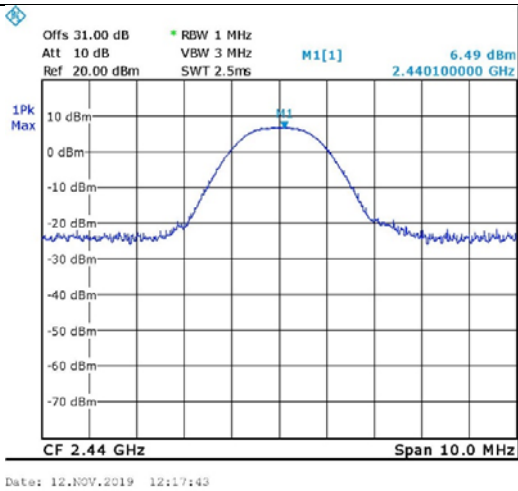

Figure 36. 2440.0 MHz, BLE

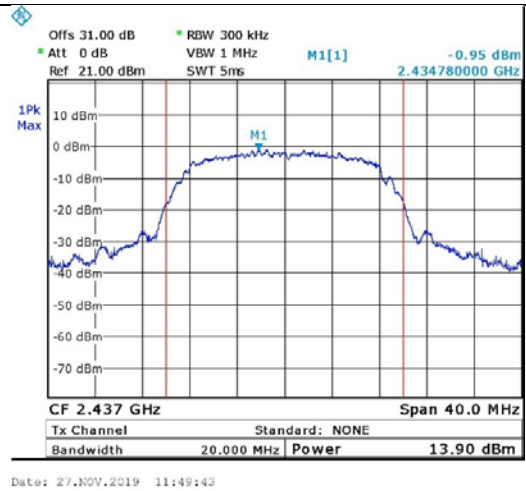

Figure 37. 2437.0 MHz, Wi-fi/g(6Mbit/s)

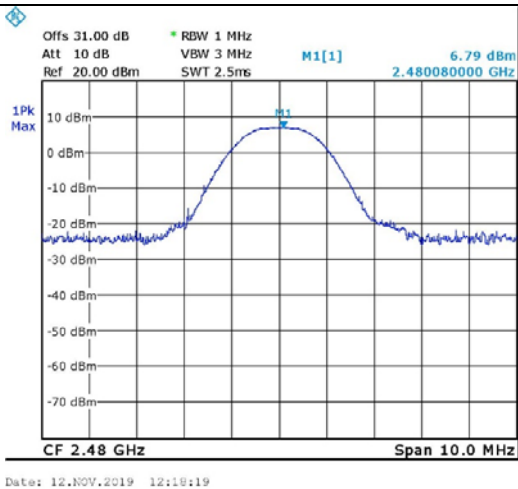

Figure 38. 2480.0 MHz, BLE

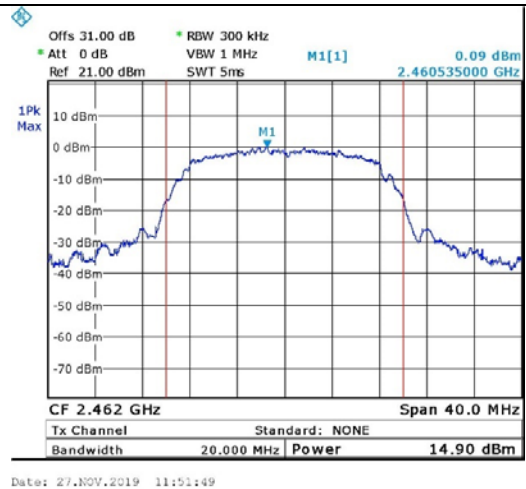

Figure 39. 2462.0 MHz, Wi-fi/g(6Mbit/s)

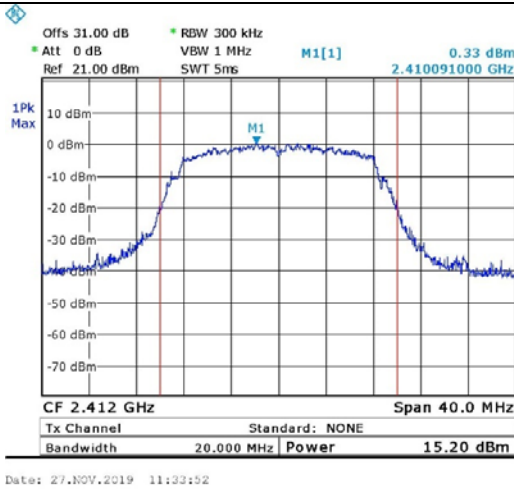

Figure 40. 2412.0 MHz, Wi-fi/g(54Mbit/s)

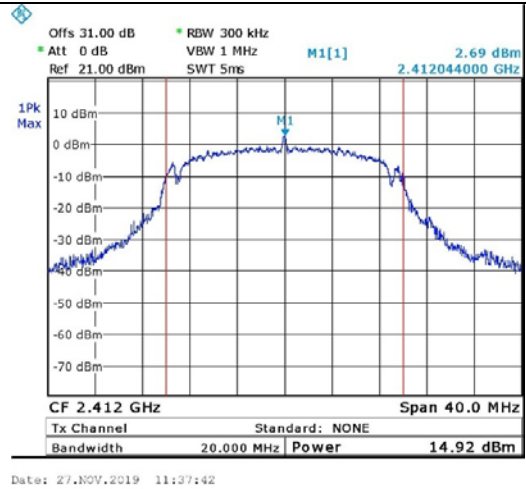

Figure 41. 2412.0 MHz, Wi-fi/n(6.5Mbit/s)

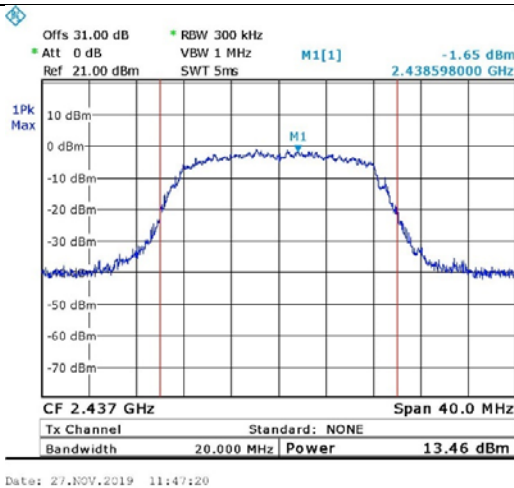

Figure 42. 2437.0 MHz, Wi-fi/g(54Mbit/s)

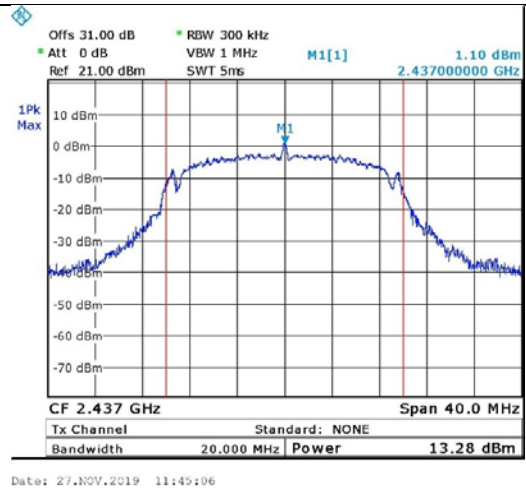

Figure 43. 2437.0 MHz, Wi-fi/n(6.5Mbit/s)

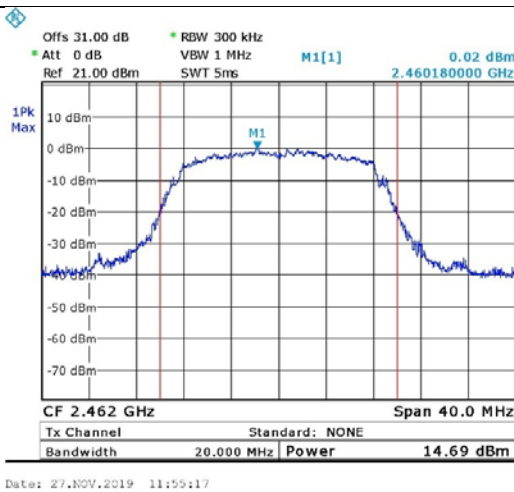

Figure 44. 2462.0 MHz, Wi-fi/g(54Mbit/s)

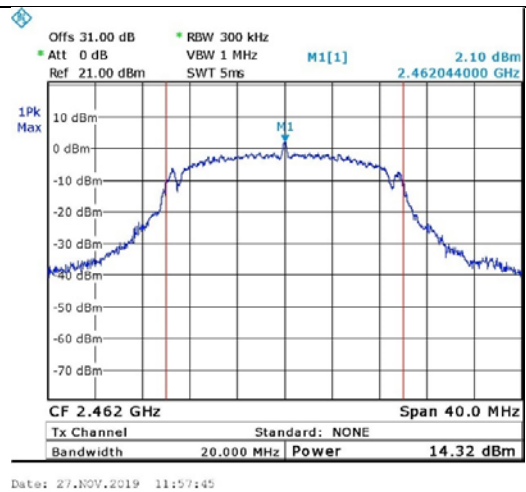

Figure 45. 2462.0 MHz, Wi-fi/n(6.5Mbit/s)

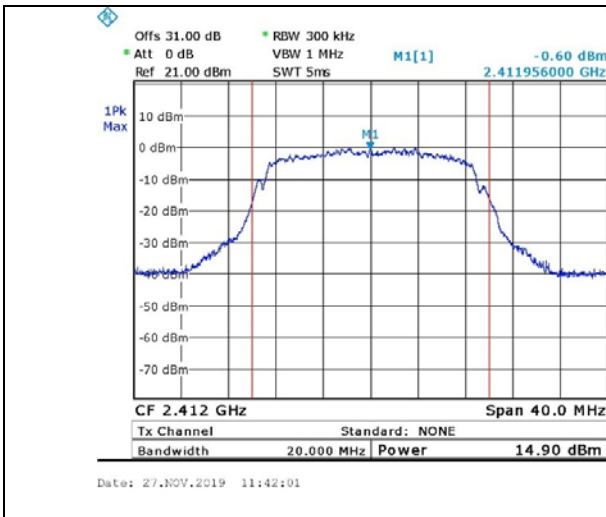

Figure 46. 2412.0 MHz, Wi-fi/n(65Mbit/s)

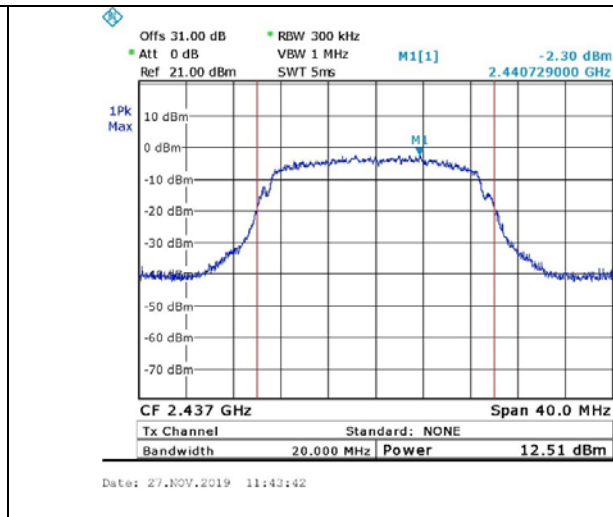

Figure 47. 2437.0 MHz, Wi-fi/n(65Mbit/s)

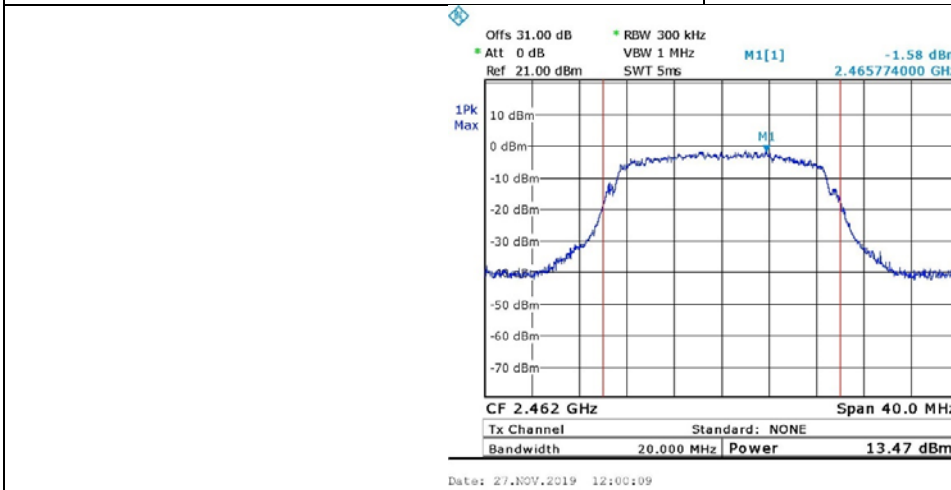

Figure 48. 2462.0 MHz, Wi-fi/n(65Mbit/s)

### 6.5 Test Equipment Used; Maximum Peak Power Output

Instrument	Manufacturer	Model	Serial No.	Last Calibration Date	Next Calibration Due
Spectrum Analyzer	R&S	FSL6	100194	March 24, 2019	March 31, 2020
30dB Attenuator	MCL	BW-S30W5	533	December 24, 2018	December 31, 2019
RF Cable	Huber Suner	Sucoflex	27502/4PEA	December 24, 2018	December 31, 2019
RF Cable	EIM	705A009301 EIM	-	December 24, 2018	December 31, 2019

Figure 49 Test Equipment Used



## 7. Band Edge Spectrum

### 7.1 Test Specification

FCC, Part 15, Subpart C, Section 247(d)

### 7.2 Test Procedure

(Temperature (20°C)/ Humidity (62%RH))

The E.U.T operation mode and test set-up are as described in Section 2 of this report.

The E.U.T. antenna terminal was connected to the Spectrum Analyzer through an external attenuator and an appropriate coaxial cable. Special attention was taken to prevent Spectrum Analyzer RF input overload.

The RBW was set to 100 kHz.

### 7.3 Test Limit

In any 100 kHz bandwidth outside the frequency band in which the spread spectrum or digitally modulated intentional radiator is operating, the radio frequency power that is produced by the intentional radiator shall be at least 20 dB below that in the 100 kHz bandwidth within the band that contains the highest level of the desired power.



#### 7.4 Test Results

Protocol Type	Operation Frequency	Band Edge Frequency	Spectrum Level	Limit	Margin
	(MHz)	(MHz)	(dBm)	(dBm)	(dB)
BLE	2402.0	2400.0	-38.0	-14.9	-23.1
	2480.0	2483.5	-38.9	-14.3	-24.6
Wi-fi/g(6Mbit/s)	2412.0	2400.0	-23.7	-15.5	-8.2
	2462.0	2483.5	-34.5	-16.4	-18.1
Wi-Fi/g(54Mbit/s)	2412.0	2400.0	-27.6	-17.0	-10.6
	2462.0	2483.5	-37.1	-18.5	-18.6
Wi-Fi/n(6.5Mbit/s)	2412.0	2400.0	-22.6	-17.2	-5.4
	2462.0	2483.5	-35.2	-16.9	-18.3
Wi-fi/n(65Mbit/s)	2412.0	2400.0	-29.5	-18.2	-11.3
	2462.0	2483.5	-44.1	-19.2	-24.9

**Figure 50 Band Edge Spectrum**

JUDGEMENT: Passed by 5.4 dB

For additional information see *Figure 51* and *Figure 60*.

## Band Edge Spectrum

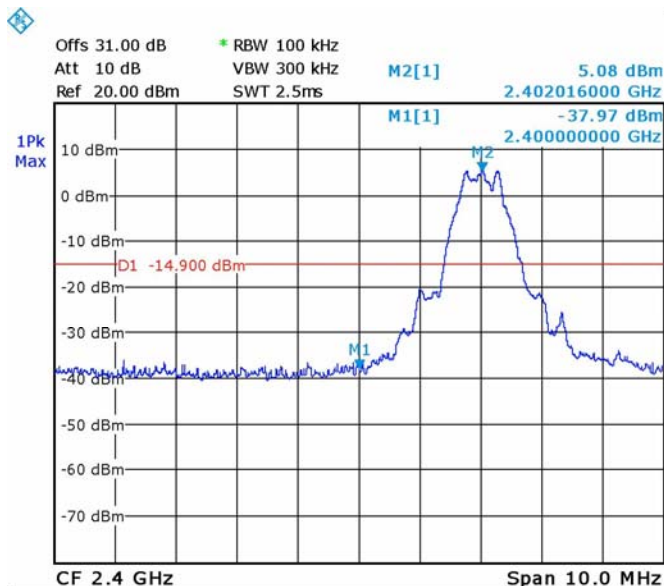

Date: 12.NOV.2019 12:25:18

Figure 51 Band Edge Low, BLE

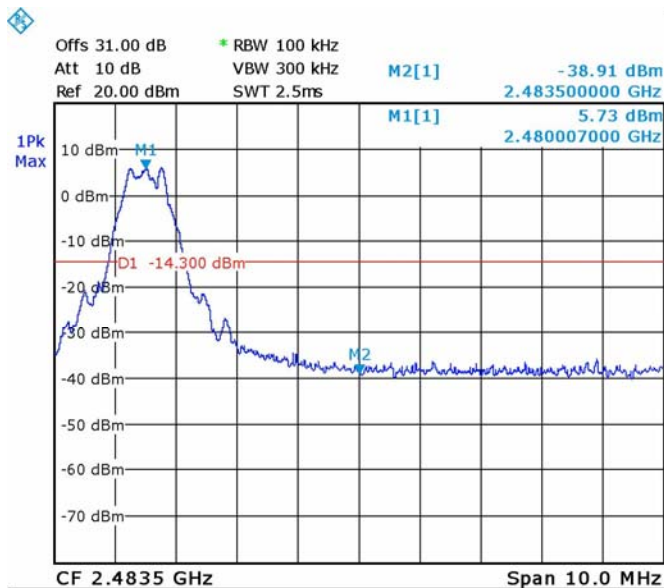

Date: 12.NOV.2019 12:24:09

Figure 52 Band Edge High, BLE

# Band Edge Spectrum

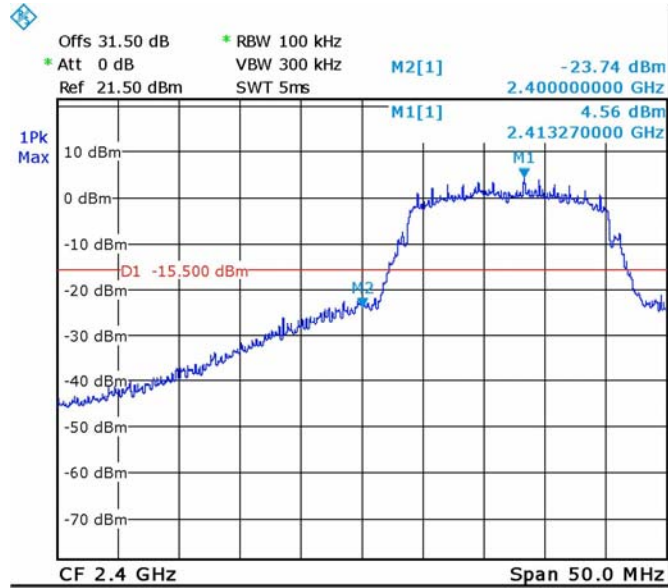

Date: 18.NOV.2019 06:42:28

Figure 53 Band Edge Low, Wi-fi/g(6Mbit/s)

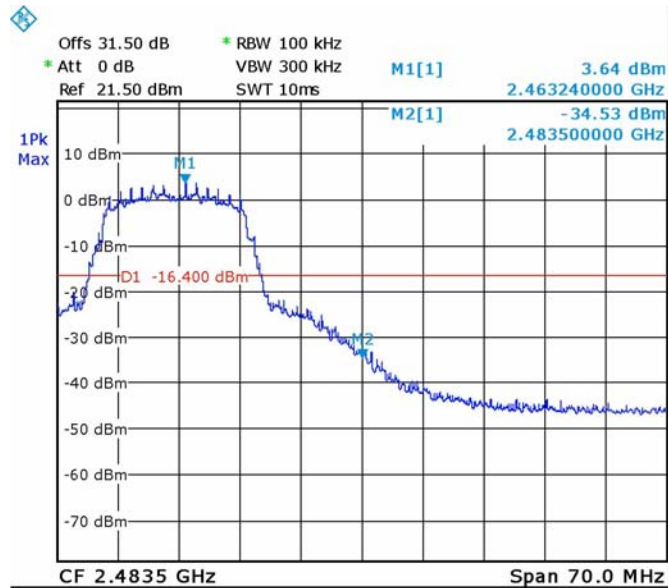

Date: 18.NOV.2019 07:18:53

Figure 54 Band Edge High, Wi-fi/g(6Mbit/s)

# Band Edge Spectrum

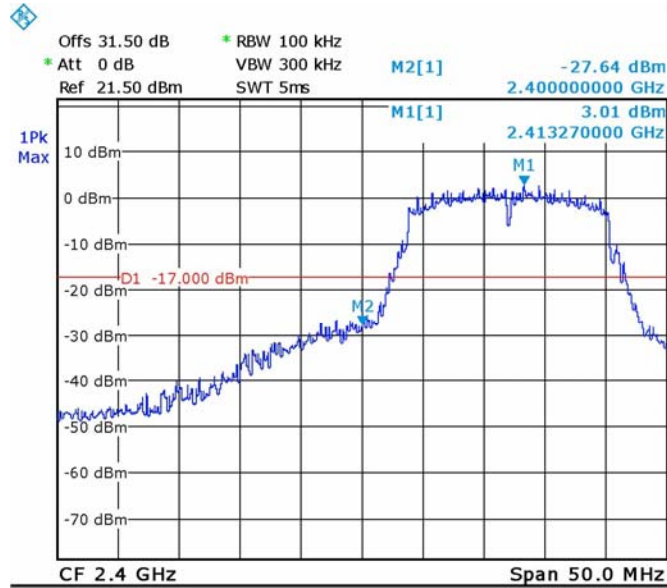

Date: 18.NOV.2019 06:21:49

Figure 55 Band Edge Low, Wi-fi/g(54Mbit/s)

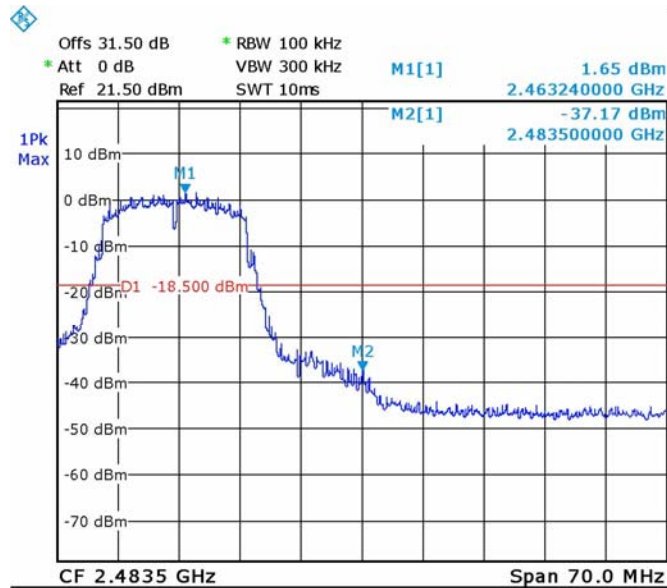

Date: 18.NOV.2019 07:22:42

Figure 56 Band Edge High, Wi-fi/g(54Mbit/s)

## Band Edge Spectrum

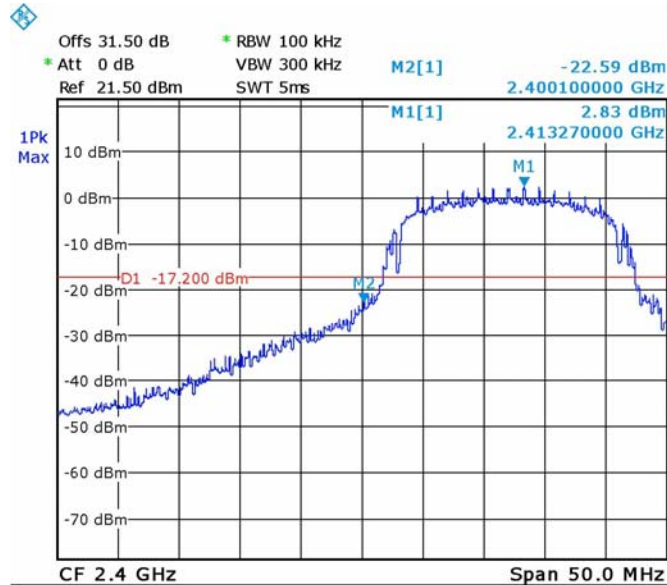

Date: 18.NOV.2019 06:45:05

Figure 57 Band Edge Low, Wi-fi/n(6.5Mbit/s)

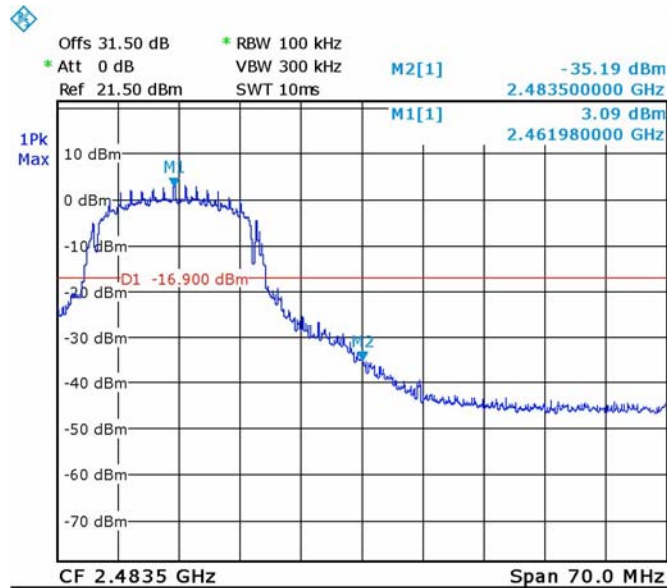

Date: 18.NOV.2019 07:05:44

Figure 58 Band Edge High, Wi-fi/n(6.5Mbit/s)

## Band Edge Spectrum

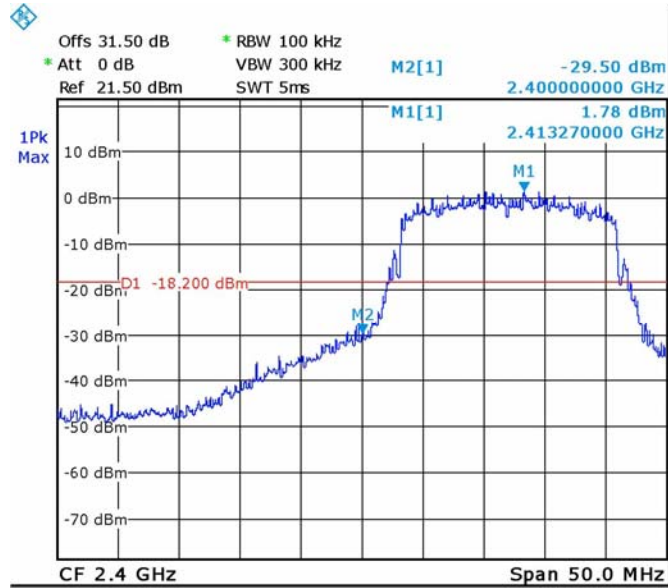

Date: 18.NOV.2019 06:48:48

Figure 59 Band Edge Low, Wi-fi/n(65Mbit/s)

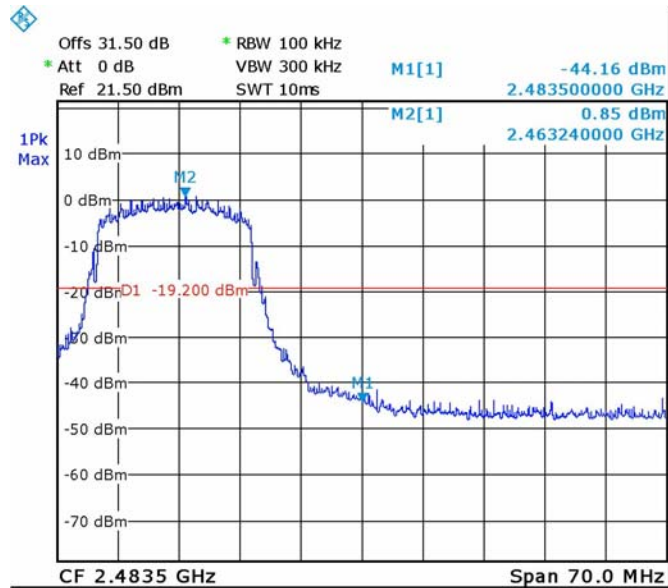

Date: 18.NOV.2019 06:57:50

Figure 60 Band Edge High, Wi-fi/n(65Mbit/s)



### 7.5 Test Equipment Used; Band Edge

<b>Instrument</b>	<b>Manufacturer</b>	<b>Model</b>	<b>Serial No.</b>	<b>Last Calibration Date</b>	<b>Next Calibration Due</b>
Spectrum Analyzer	R&S	FSL6	100194	March 24, 2019	March 31, 2020
30dB Attenuator	MCL	BW-S30W5	533	December 24, 2018	December 31, 2019
RF Cable	Huber Suner	Sucofelex	27502/4PEA	December 24, 2018	December 31, 2019
RF Cable	EIM	705A00930 1EIM	-	December 24, 2018	December 31, 2019

**Figure 61 Test Equipment Used**