



DATE: 31 December 2020

**I.T.L. (PRODUCT TESTING) LTD.
FCC Radio Test Report
for
Orcam Technologies Ltd.**

Equipment under test:

**Wearable Assistive Technology
Device for People With Hearing
Impairment**

**Orcam Hear
Wifi/BLE**

Tested by: _____

M. Zohar

Approved by: _____

D. Shidlowky

This report must not be reproduced, except in full, without the written permission of I.T.L. (Product Testing) Ltd.

This report relates only to items tested.



Measurement/Technical Report for Orcam Technologies Ltd.

Wearable Assistive Technology Device for People With Hearing Impairment

Orcam Hear

FCC ID: 2AAWI-HEAR

This report concerns:	Original Grant: X
	Class I Change:
	Class II Change:
Equipment type:	FCC: (DTS) Digital Transmission System
Limits used:	47CFR15 Section 15.247

Measurement procedure used is KDB 558074 D01 v05r02 and ANSI C63.10:2013

Application for Certification
prepared by:

R. Pinchuck
ITL (Product Testing) Ltd.
1 Bat Sheva St.
Lod 7116002
e-mail Rpinchuck@itlglobal.org

Applicant for this device:
(different from "prepared by")

Bar Massad
3 Kiryat Mada St.
PO Box 45157
Jerusalem, 9777603, Israel
Tel: +972-2-591-7805
Fax: +972-2-586-0121
e-mail: : Bar.Massad@orcaml.com



TABLE OF CONTENTS

1.	GENERAL INFORMATION	5
1.1	Administrative Information	5
1.2	List of Accreditations	6
1.3	Product Description	7
1.4	Test Methodology	7
1.5	Test Facility	7
1.6	Measurement Uncertainty	8
2.	SYSTEM TEST CONFIGURATION	9
2.1	Justification	9
2.2	EUT Exercise Software	10
2.3	Special Accessories	10
2.4	Equipment Modifications	10
2.5	Configuration of Tested System	10
3.	CONDUCTED & RADIATED MEASUREMENT TEST SET-UP PHOTOS	11
4.	CONDUCTED EMISSION FROM AC MAINS	15
4.1	Test Specification	15
4.2	Test Procedure	15
4.3	Test Limit	15
4.4	Test Results	16
4.5	Test Equipment Used; Conducted Emission from AC Mains	21
5.	6 DB MINIMUM BANDWIDTH	22
5.1	Test Specification	22
5.2	Test Procedure	22
5.3	Test Limit	22
5.4	Test Results	23
5.5	Test Equipment Used; 6dB Bandwidth	26
6.	MAXIMUM CONDUCTED OUTPUT POWER	27
6.1	Test Specification	27
6.2	Test Procedure	27
6.3	Test Limit	27
6.4	Test Results	27
6.5	Test Equipment Used; Maximum Peak Power Output	30
7.	BAND EDGE SPECTRUM	31
7.1	Test Specification	31
7.2	Test Procedure	31
7.3	Test Limit	31
7.4	Test Results	32
7.5	Test Equipment Used; Band Edge	38
8.	TRANSMITTED POWER DENSITY	39
8.1	Test Specification	39
8.2	Test Procedure	39
8.3	Test Limit	39
8.4	Test Results	40
8.5	Test Equipment Used; Transmitted Power Density	44
9.	OCCUPIED BANDWIDTH	45
9.1	Test Specification	45
9.2	Test Procedure	45
9.3	Test Limit	45
9.4	Test Results	46
9.5	Test Equipment Used; Occupied Bandwidth	50



10.	EMISSIONS IN NON-RESTRICTED FREQUENCY BANDS-----	51
10.1	Test Specification	51
10.2	Test Procedure	51
10.3	Test Limit	51
10.4	Test Results.....	51
10.5	Test Instrumentation Used, Emissions in Non Restricted Frequency Bands	57
11.	EMISSIONS IN RESTRICTED FREQUENCY BANDS -----	58
11.1	Test Specification	58
11.2	Test Procedure	58
11.3	Test Limit	59
11.4	Test Results for BLE	59
11.5	Test Results for WiFi	60
11.6	Test Instrumentation Used; Emissions in Restricted Frequency Bands ...	66
12.	ANTENNA GAIN/INFORMATION-----	67
13.	R.F EXPOSURE/SAFETY-----	68
14.	APPENDIX A - CORRECTION FACTORS -----	70
14.1	Correction factors for RF OATS Cable 35m ITL #1911	70
14.2	Correction factor for RF cable for Anechoic Chamber	71
14.3	Correction factors for Active Loop Antenna ITL # 1075:	72
14.4	Correction factors for biconical antenna ITL #1356	73
14.5	Correction factors for log periodic antenna ITL # 1349.....	74
14.6	Correction factors for Double –Ridged Waveguide Horn ANTENNA ITL # 1352.....	75
14.7	Correction factors for Horn Antenna Model: SWH-28.....	76



1. General Information

1.1 Administrative Information

Manufacturer:	Orcam Technologies Ltd.
Manufacturer's Address:	3 Kiryat Mada St. P.O. Box 45157 Jerusalem, 9777603, Israel Tel: +972-2-591-7805 Fax: +972-2-586-0121
Manufacturer's Representative:	Bar Massad
Equipment Under Test (E.U.T):	Wearable Assistive Technology Device for People With Hearing Impairment
Equipment PMN:	Orcam Hear
Equipment Serial No.:	19491402
Date of Receipt of E.U.T:	August 09, 2020
Start of Test:	August 09, 2020
End of Test:	December 08, 2020
Test Laboratory Location:	I.T.L (Product Testing) Ltd. 1 Batsheva St., Lod ISRAEL 7120101
Test Specifications:	FCC Part 15, Subpart C, Section 15.247



1.2 **List of Accreditations**

The EMC laboratory of I.T.L. is accredited by the following bodies:

1. The American Association for Laboratory Accreditation (A2LA) (U.S.A.), Certificate No. 1152.01.
2. The Federal Communications Commission (FCC) (U.S.A.), FCC Designation No. IL1005.
3. The Israel Ministry of the Environment (Israel), Registration No. 1104/01.
4. Department of Innovation, Science and Economic Development (ISED) Canada, CAB identifier: IL1002; ISED File# 4025A.

I.T.L. Product Testing Ltd. is accredited by the American Association for Laboratory Accreditation (A2LA) and the results shown in this test report have been determined in accordance with I.T.L.'s terms of accreditation unless stated otherwise in the report.



1.3 **Product Description**

OrCam Hear is an AI-driven, wearable assistive technology device for people with hearing impairment. It makes hearing aids smart by identifying and isolating a speaker's voice from among multiple speakers – and then instantly relaying the clear speech to hearing aids or destined earphones.

Working voltage	5.0VDC Rechargeable battery via AC/DC adapter
Mode of operation	Transceiver
Modulations	For Wi-Fi/g: OFDM(BPSK,QPSK,16QAM ,64QAM) For Wi-Fi/n: OFDM(BPSK,QPSK,16QAM ,64QAM) For BLE: GFSK
Assigned Frequency Range	2400.0-2483.5MHz
Operating Frequency Range	For Wi-Fi/g/n: 2412.0-2462.0MHz For BLE: 2402.0-2480.0MHz
Conducted power	~ 22.0dBm (Wi-Fi mode)
Antenna Gain	-3.66 dBi
Modulation BW	For Wi-Fi/g/n: 20MHz For BLE: 2MHz
Bit rate (Mbit/s)	For Wi-Fi/g: 6, 9, 12, 18, 24, 36, 48, 54 For Wi-Fi/n: 6.5,13,19.5,26,39,52,58.5,65 For BLE: 1,2,3

1.4 **Test Methodology**

Both conducted and radiated testing was performed according to the procedures in KDB 558074 D01 v05 r02 and ANSI C63.10: 2013. Radiated testing was performed at an antenna to EUT distance of 3 meters.

1.5 **Test Facility**

Emissions tests were performed at I.T.L.'s testing facility in Lod, Israel. I.T.L.'s EMC Laboratory is accredited by A2LA, certificate No. 1152. 01. Its FCC Designation Number is IL1005 and (ISED) Canada, CAB identifier: IL1002; ISED File# 4025A.



1.6 **Measurement Uncertainty**

Conducted Emission

Conducted Emission (CISPR 11, EN 55011, CISPR 22, EN 55022, ANSI C63.4)

0.15 – 30 MHz:

Expanded Uncertainty (95% Confidence, K=2):

± 3.44 dB

Radiated Emission

Radiated Emission (CISPR 11, EN 55011, CISPR 22, EN 55022, ANSI C63.4) for open site:

30-1000MHz:

Expanded Uncertainty (95% Confidence, K=2):

± 4.96 dB

1 GHz to 6 GHz

Expanded Uncertainty (95% Confidence, K=2):

±5.19 dB

>6 GHz

Expanded Uncertainty (95% Confidence, K=2):

±5.51 dB

2. System Test Configuration

2.1 Justification

1. The E.U.T contains 2 optional transceivers: IEEE 802.15.1 standard (BLE) or IEEE 802.11g/n standard (Wi-Fi/g/n) with only 20MHz CBW.
2. For BLE - The unit was evaluated while transmitting at the low channel (2402MHz), the mid channel (2440MHz) and the high channel (2480MHz).
For Wi-Fi /g/n - The unit was evaluated while transmitting at the low channel (2412MHz), the mid channel (2437MHz) and the high channel (2462MHz).
3. The evaluation was performed while the E.U.T was connected to an AC/DC power supply in charge mode as the “worst case”.
4. Conducted emission tests were performed with the E.U.T. antenna terminal connected by a RF cable to the Spectrum Analyzer through a 30dB external attenuator.
5. Final radiated emission for Wi-Fi g/n modes tests were performed using the lowest and highest bit rates for each different protocol type. The bit rates for each protocol are shown in the table below:

Protocol Type	“Worst Case” Bit Rate
Wi-Fi/g	6,54 Mbit/s
Wi-Fi/n	6.5,65 Mbit/s (MCS0,MCS7)

7. Final radiated emission tests were performed after exploratory emission testing that was performed in 3 orthogonal polarities to determine the “worst case” radiation. According to below results the worst case was at the Z axis for band edge and at Y axis for spurious emission.

Orientation	Frequency	2 nd Harmonic	3 rd Harmonic	Band Edge
	(MHz)	(dBuV/m)	(dBuV/m)	(dBuV/m)
X axis	2412.0	59.8	62.4	63.0
	2437.0	55.2	57.8	-
	2462.0	60.4	63.4	61.4
Y axis	2412.0	61.0	67.0	58.5
	2437.0	56.0	61.2	-
	2462.0	62.3	66.3	61.5
Z axis	2412.0	60.4	66.1	63.4
	2437.0	54.6	60.6	-
	2462.0	62.0	65.4	64.1

Figure 1. Screening Results

2.2 EUT Exercise Software

No special exercise software was used.

2.3 Special Accessories

Equipment	Manufacturer	Part Number	Serial Number
AC/DC power supply	Shenzhen Super Eagle Technology Co. Ltd	CH06-050200-EU	N/A

2.4 Equipment Modifications

No modifications were needed in order to achieve compliance.

2.5 Configuration of Tested System

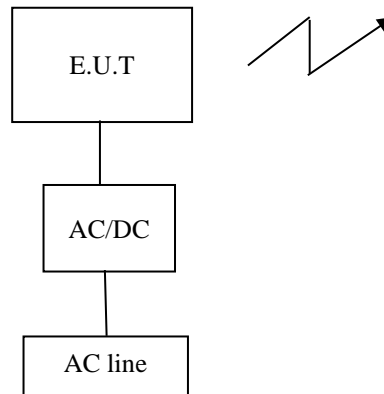

Figure 2. Configuration of Tested System – Radiated

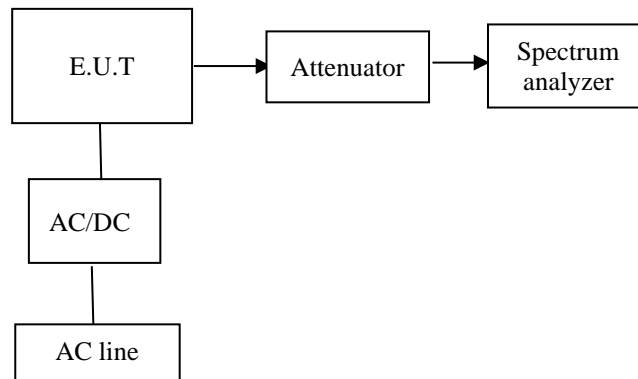

Figure 3. Configuration of Tested System - Conducted

3. Conducted & Radiated Measurement Test Set-Up Photos



Figure 4. Conducted Emission Test from AC Line Test

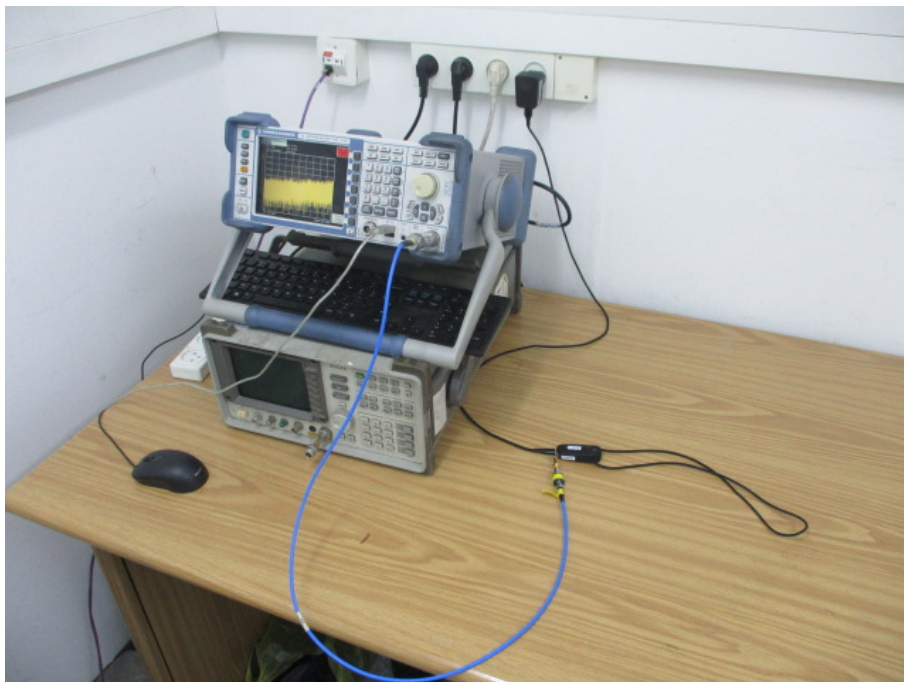

Figure 5. Conducted Test Set-Up



Figure 6. Radiated Emission Test, 0.009-30MHz

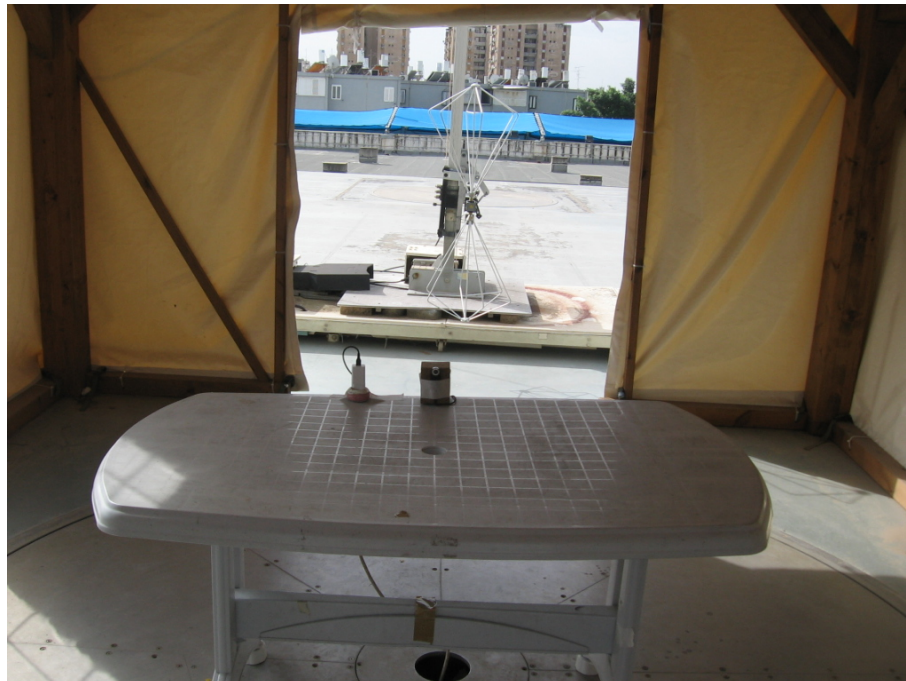

Figure 7. Radiated Emission Test, 30-200MHz



Figure 8. Radiated Emission Test, 200-1000MHz



Figure 9. Radiated Emission Test, 1-18GHz



Figure 10. Radiated Emission Test, 18-26.5GHz

4. Conducted Emission From AC Mains

4.1 Test Specification

FCC Part 15, Subpart C, Section 15.207

4.2 Test Procedure

(Temperature (20°C)/ Humidity (55%RH))

The E.U.T operation mode and test setup are as described in Section 2 of this report. In order to minimize background noise interference, the conducted emission testing was performed inside a shielded room, with the E.U.T placed on a 0.8 meter high wooden table, 0.4 meter from the room's vertical wall. In the case of a floor-standing E.U.T., it was placed on the horizontal ground plane.

The E.U.T was powered from 115 V AC / 60 Hz via 50 Ohm / 50 μ Hn Line Impedance Stabilization Network (LISN) on the phase and neutral lines. The LISN's were grounded to the shielded room ground plane (floor), and were kept at least 0.8 meters from the nearest boundary of the E.U.T.

The center of the E.U.T.'s AC cable was folded back and forth, in order to form a bundle less than 0.40 meters and a total cable length of 1 meter.

The effect of varying the position of the cables was investigated to find the configuration that produces maximum emission. The configurations tested are shown in the photographs, *Figure 4* and *Figure 5*.

The emission voltages at the LISN's outputs were measured using a computerized receiver, complying with CISPR 16 requirements. The specification limits are loaded to the receiver and are displayed on the receiver's spectrum display.

The E.U.T was evaluated in TX operation mode (WI-FI/g 6Mbps)

A frequency scan between 0.15 and 30 MHz was performed at 9 kHz I.F. band width, using peak detection.

The spectral components having the highest level on each line were measured using a quasi-peak and average detector.

4.3 Test Limit

Frequency of emission (MHz)	Conducted limit (dB μ V)	
	Quasi-peak	Average
0.15-0.5	66 to 56*	56 to 46*
0.5-5	56	46
5-30	60	50

* Decreases with the logarithm of the frequency.



4.4 Test Results

JUDGEMENT: Passed by 4.94 dB

The margin between the emission levels and the specification limit is, in the worst case, 17.17 dB for the phase line at 24.02 MHz and 17.994 dB at 24.02 MHz for the neutral line.

The EUT met the F.C.C. Part 15, Subpart C specification requirements.

The details of the highest emissions are given in *Figure 11* to *Figure 14*.



Conducted Emission

E.U.T Description Wearable Assistive Technology Device for
People With Hearing Impairment

Type Orcam Hear

Serial Number: 19491402

Specification: FCC Part 15, Subpart C

Lead: Phase

Detectors: : Peak, Quasi-peak, Average

Power Operation AC/DC power supply

EDIT PEAK LIST (Final Measurement Results)				
Trace1:	CE22BQP			
Trace2:	CE22BAP			
Trace3:	---			
	TRACE	FREQUENCY	LEVEL dBuV	DELTA LIMIT dB
1	Quasi Peak	194 kHz	29.88	-33.97
2	Average	194 kHz	16.75	-37.11
1	Quasi Peak	426 kHz	30.27	-27.06
2	Average	426 kHz	21.35	-25.97
2	Average	582 kHz	20.13	-25.86
1	Quasi Peak	598 kHz	29.76	-26.23
2	Average	914 kHz	13.60	-32.39
1	Quasi Peak	922 kHz	22.81	-33.19
1	Quasi Peak	1.274 MHz	26.90	-29.09
2	Average	1.274 MHz	13.00	-32.99
2	Average	2.482 MHz	8.90	-37.09
1	Quasi Peak	3.258 MHz	17.30	-38.69
2	Average	4.002 MHz	10.63	-35.36
1	Quasi Peak	4.042 MHz	15.98	-40.01
1	Quasi Peak	6.342 MHz	14.52	-45.48
2	Average	9.858 MHz	7.77	-42.22
1	Quasi Peak	13.254 MHz	23.83	-36.16
2	Average	13.938 MHz	21.82	-28.17
1	Quasi Peak	24.022 MHz	32.83	-27.16
2	Average	24.022 MHz	32.82	-17.17

Date: 6.DEC.2020 17:14:39

Figure 11. Detectors: Peak, Quasi-peak, Average

Note: QP Delta/Av Delta refers to the test results obtained minus specified requirement; thus a positive number indicates failure, and a negative result indicates that the product passes the test.

Conducted Emission

E.U.T Description Wearable Assistive Technology Device for
People With Hearing Impairment

Type Orcam Hear

Serial Number: 19491402

Specification: FCC Part 15, Subpart C

Lead: Phase

Detectors: Peak, Quasi-peak, Average

Power Operation AC/DC power supply

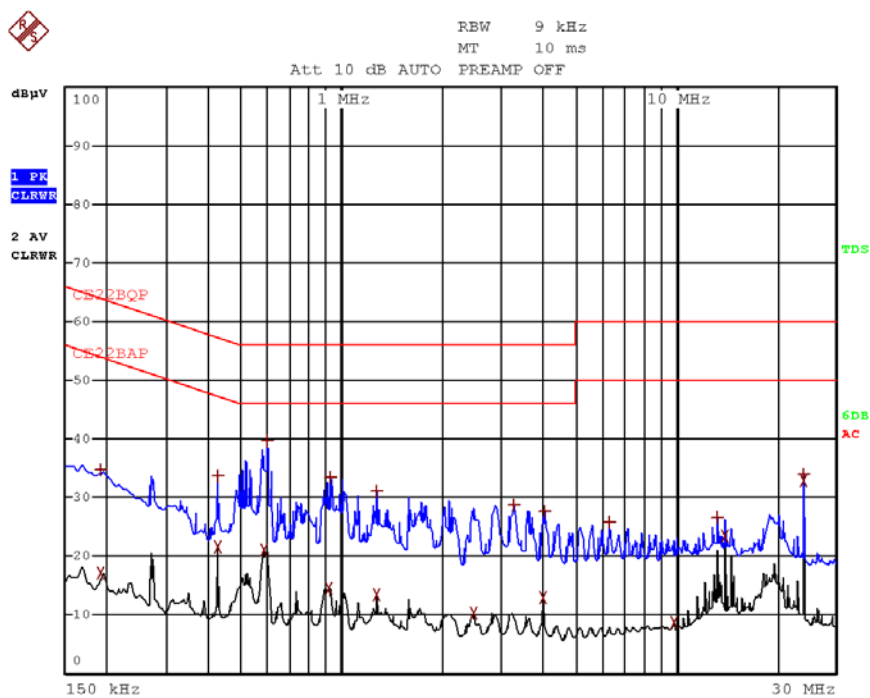

Date: 6.DEC.2020 16:58:33

Figure 12. Detectors: Peak, Quasi-peak, Average



Conducted Emission

E.U.T Description Wearable Assistive Technology Device for
People With Hearing Impairment
Type Orcam Hear
Serial Number: 19491402

Specification: FCC Part 15, Subpart C
Lead: Neutral
Detectors: Peak, Quasi-peak, Average
Power Operation AC/DC power supply

EDIT PEAK LIST (Final Measurement Results)				
Trace1:		CE22BQP		
Trace2:		CE22BAP		
Trace3:		---		
	TRACE	FREQUENCY	LEVEL dBμV	DELTA LIMIT dB
1	Quasi Peak	170 kHz	31.78	-33.17
2	Average	238 kHz	10.99	-41.16
1	Quasi Peak	426 kHz	22.15	-35.17
2	Average	426 kHz	12.00	-35.33
1	Quasi Peak	578 kHz	27.48	-28.51
2	Average	578 kHz	14.78	-31.22
1	Quasi Peak	870 kHz	22.61	-33.39
2	Average	990 kHz	10.92	-35.07
1	Quasi Peak	1.274 MHz	22.95	-33.04
2	Average	1.274 MHz	11.03	-34.96
1	Quasi Peak	2.466 MHz	17.33	-38.67
2	Average	3.282 MHz	7.93	-38.06
2	Average	4.002 MHz	10.15	-35.84
1	Quasi Peak	4.078 MHz	19.08	-36.91
1	Quasi Peak	9.418 MHz	13.30	-46.69
2	Average	9.858 MHz	10.34	-39.65
1	Quasi Peak	13.938 MHz	30.54	-29.45
2	Average	13.938 MHz	28.90	-21.09
1	Quasi Peak	24.022 MHz	32.30	-27.69
2	Average	24.022 MHz	32.00	-17.99

Date: 6.DEC.2020 17:26:47

Figure 13. Detectors: Peak, Quasi-peak, Average

Note: QP Delta/Av Delta refers to the test results obtained minus specified requirement; thus a positive number indicates failure, and a negative result indicates that the product passes the test.

Conducted Emission

E.U.T Description Wearable Assistive Technology Device for
People With Hearing Impairment
Type Orcam Hear
Serial Number: 19491402

Specification: FCC Part 15, Subpart C
Lead: Neutral
Detectors: Peak, Quasi-peak, Average
Power Operation AC/DC power supply

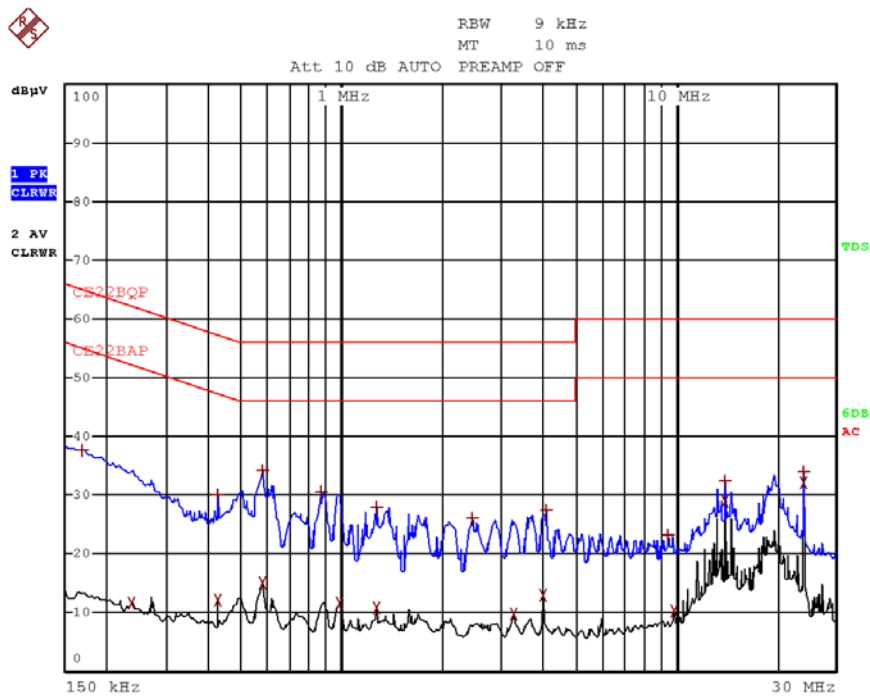

Date: 6.DEC.2020 17:24:55

Figure 14 Detectors: Peak, Quasi-peak, Average



4.5 *Test Equipment Used; Conducted Emission from AC Mains*

Instrument	Manufacturer	Model	Serial No.	Last Calibration Date	Next Calibration Due
LISN	Fischer	FCC-LISN-25A	127	October 28, 2020	October 31, 2021
Transient Limiter	HP	11947A	3107A01308	October 28, 2020	October 31, 2021
EMI Receiver	Rohde & Schwarz	ESCI7	100724	March 9, 2020	March 31, 2021
RF Cable CE Chamber 5M	Telrad	RJ214	-	October 28, 2020	October 31, 2021

Figure 15 Test Equipment Used



5. 6 dB Minimum Bandwidth

5.1 *Test Specification*

FCC Part 15, Subpart C, Section 247(a)(2)

5.2 *Test Procedure*

(Temperature (20°C)/ Humidity (52%RH))

The E.U.T operation mode and test set-up are as described in Section 2 of this report.

The E.U.T. antenna terminal was connected to the Spectrum Analyzer through an external attenuator and an appropriate coaxial cable. Special attention was taken to prevent Spectrum Analyzer RF input overload.

The spectrum bandwidth of the E.U.T. at the point of 6 dB below maximum peak power was measured and recorded. The RBW was set to 100 kHz.

5.3 *Test Limit*

Systems using digital modulation techniques may operate in the 902-928 MHz, 2400-2483.5 MHz, and 5725-5850 MHz bands. The minimum 6 dB bandwidth shall be at least 500 kHz.

5.4 Test Results

Protocol Type	Operation Frequency	Reading	Limit
	(MHz)	(kHz)	(kHz)
BLE	2402.0	719.0	>500.0
	2440.0	709.0	>500.0
	2480.0	709.0	>500.0
Wi-fi/g(6Mbit/s)	2412.0	15,729.0	>500.0
	2437.0	15,569.0	>500.0
	2462.0	15,968.0	>500.0
Wi-fi/g(54Mbit/s)	2412.0	16,048.0	>500.0
	2437.0	16,287.0	>500.0
	2462.0	16,447.0	>500.0
Wi-fi/n(6.5Mbit/s)	2412.0	15,729.0	>500.0
	2437.0	15,968.0	>500.0
	2462.0	15,729.0	>500.0
Wi-fi/n(65Mbit/s)	2412.0	17,405.0	>500.0
	2437.0	17,325.0	>500.0
	2462.0	17,246.0	>500.0

Figure 16 6 dB Minimum Bandwidth

JUDGEMENT: Passed

For additional information see *Figure 17* to *Figure 31*.

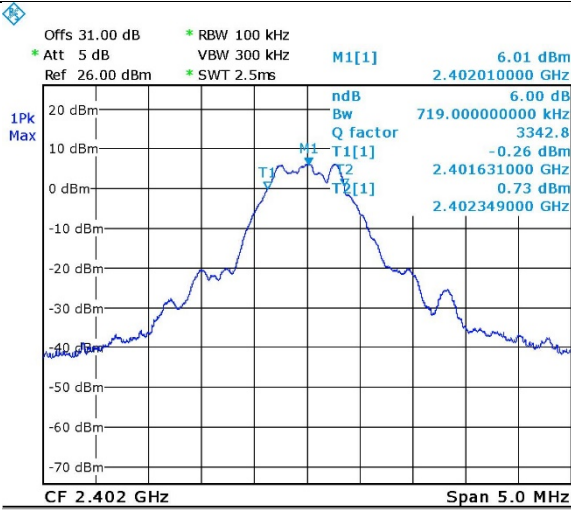

Figure 17. 2402.0 MHz, BLE

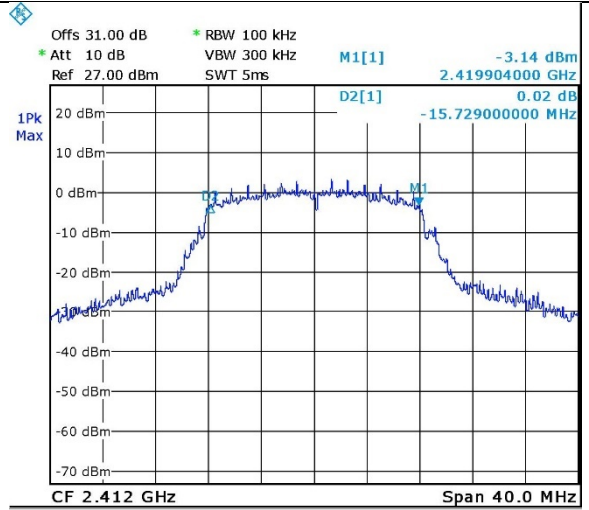

Figure 18. 2412.0 MHz, Wi-fi/g(6Mbit/s)

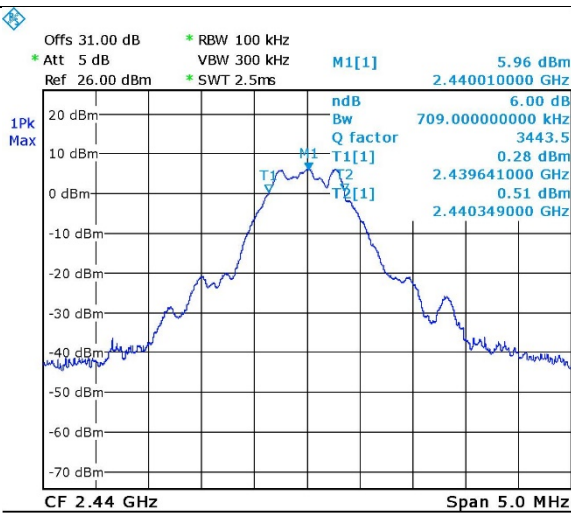

Figure 19. 2440.0 MHz, BLE

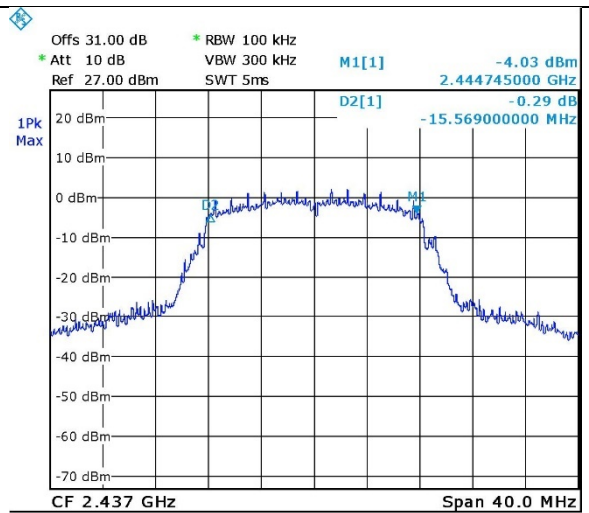

Figure 20. 2437.0 MHz, Wi-fi/g(6Mbit/s)

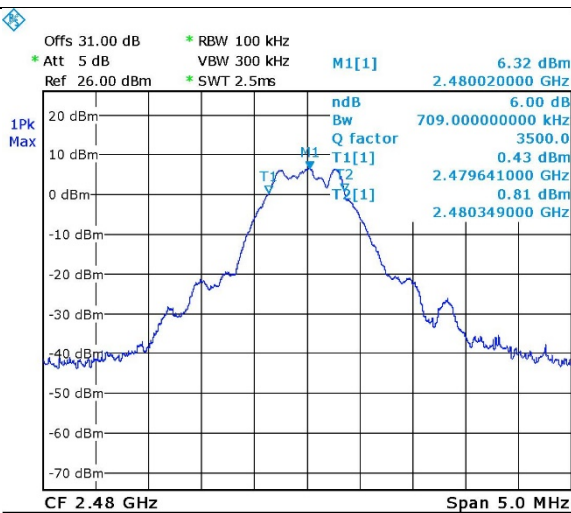

Figure 21. 2480.0 MHz, BLE

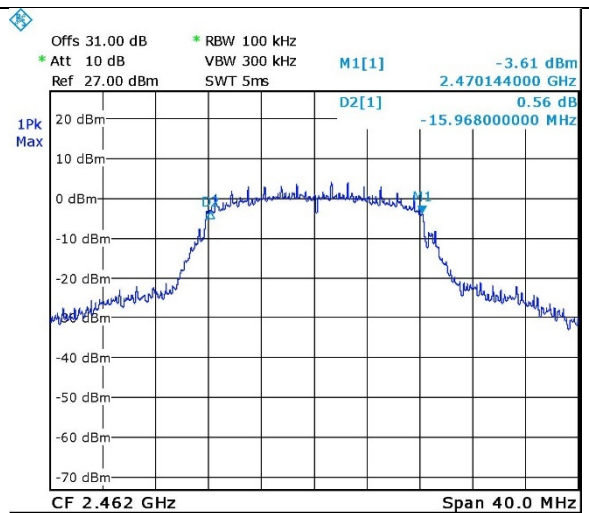

Figure 22. 2462.0 MHz, Wi-fi/g(6Mbit/s)

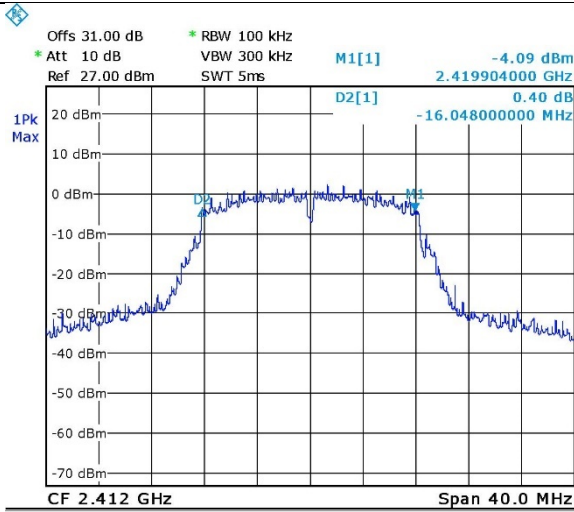

Figure 23. 2412.0 MHz, Wi-fi/g(54Mbit/s)

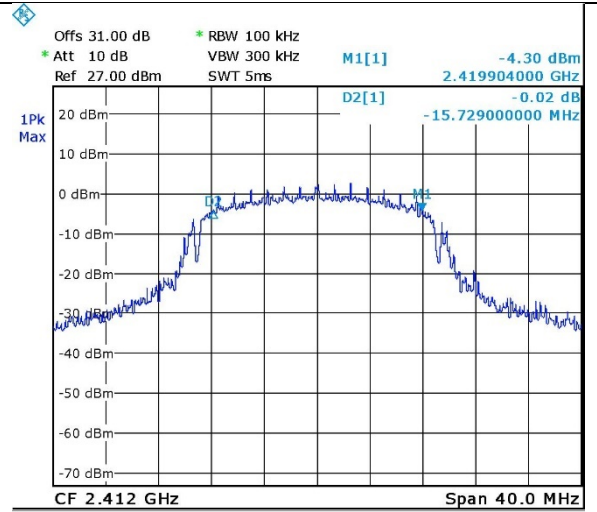

Figure 24. 2412.0 MHz, Wi-fi/n(6.5Mbit/s)

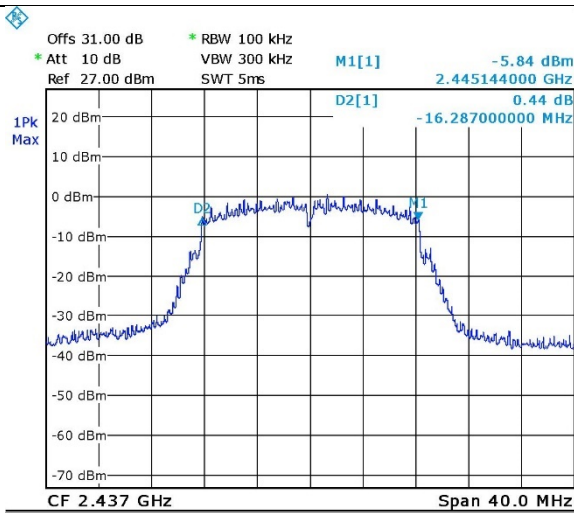

Figure 25. 2437.0 MHz, Wi-fi/g(54Mbit/s)

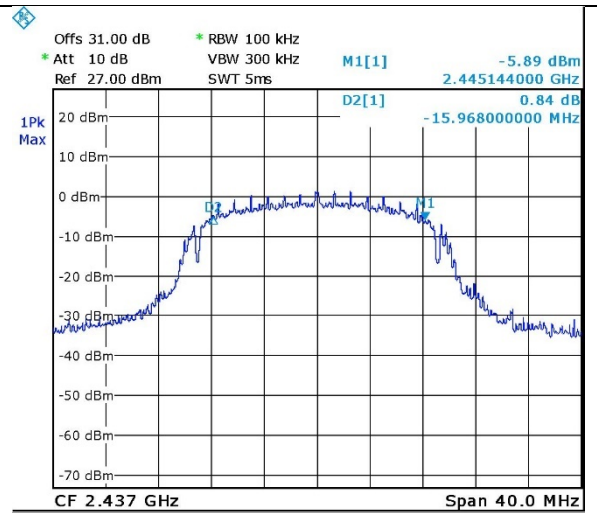

Figure 26. 2437.0 MHz, Wi-fi/n(6.5Mbit/s)

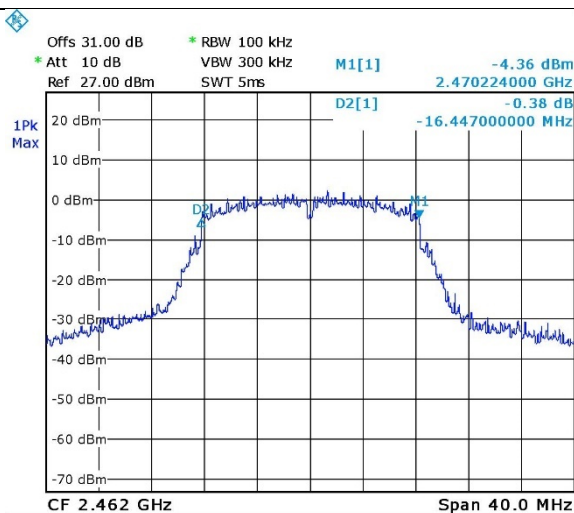

Figure 27. 2462.0 MHz, Wi-fi/g(54Mbit/s)

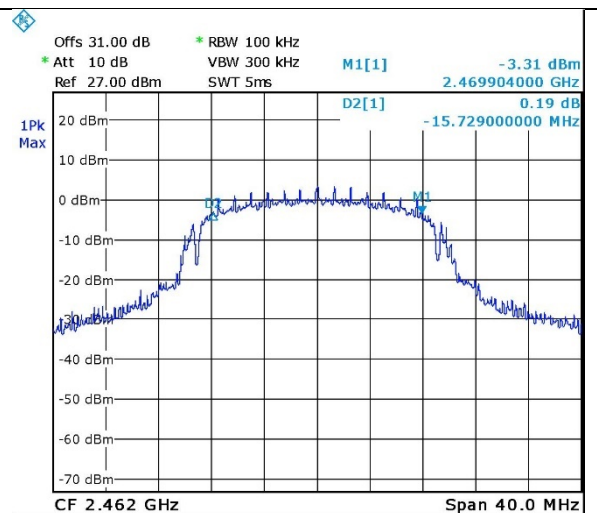

Figure 28. 2462.0 MHz, Wi-fi/n(6.5Mbit/s)

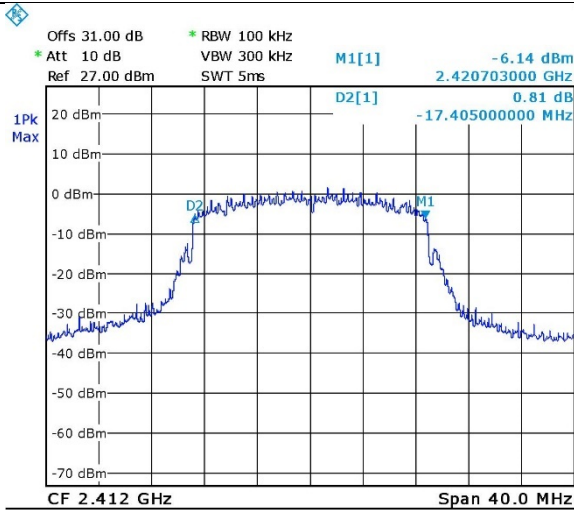

Figure 29. 2412.0 MHz, Wi-fi/n(65Mbit/s)

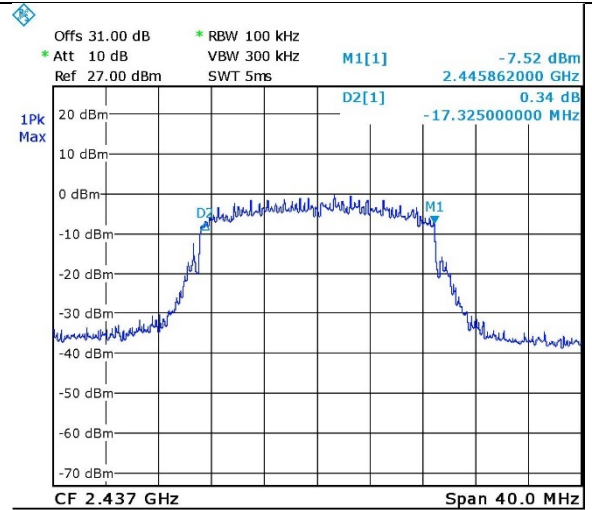

Figure 30. 2437.0 MHz, Wi-fi/n(65Mbit/s)

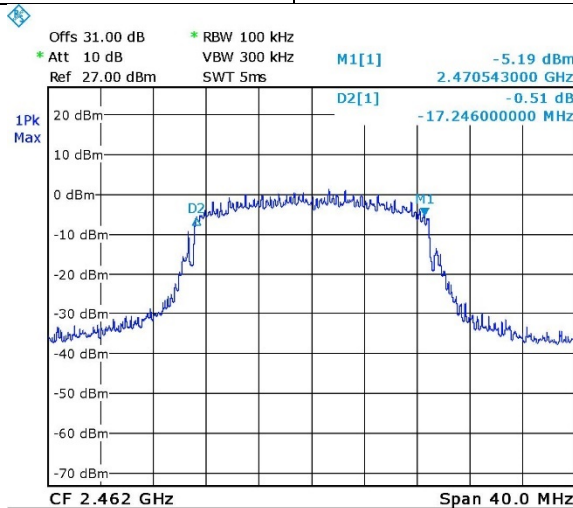

Figure 31. 2462.0 MHz, Wi-fi/n(65Mbit/s)

5.5 Test Equipment Used; 6dB Bandwidth

Instrument	Manufacturer	Model	Serial No.	Last Calibration Date	Next Calibration Due
Spectrum Analyzer	R&S	FSL6	100194	March 10, 2020	March 31, 2021
30dB Attenuator	MCL	BW-S30W5	533	August 1, 2020	August 31, 2021
RF Cable	Huber Suner	Sucofelex	27502/4PEA	August 1, 2020	August 31, 2021

Figure 32 Test Equipment Used

6. Maximum Conducted Output Power

6.1 Test Specification

FCC, Part 15, Subpart C, Section 247(b)(3)

6.2 Test Procedure

(Temperature (20°C)/ Humidity (52%RH))

The E.U.T operation mode and test set-up are as described in Section 2 of this report.

The E.U.T. antenna terminal was connected to the Spectrum Analyzer through an external attenuator and an appropriate coaxial cable. Special attention was taken to prevent Spectrum Analyzer RF input overload.

6.3 Test Limit

The maximum peak conducted output power of the intentional radiator for systems using digital modulation in the 902-928 MHz, 2400-2483.5 MHz, and 5725-5850 MHz bands: 1 Watt.

6.4 Test Results

Protocol Type	Operation Frequency	Power	Power	Limit	Margin
	(MHz)	(dBm)	(mW)	(mW)	(mW)
BLE	2402.0	6.5	4.5	1000.0	-995.5
	2440.0	6.9	4.9	1000.0	-995.1
	2480.0	7.2	5.3	1000.0	-994.7
Wi-fi/g(6Mbit/s)	2412.0	22.0	159.6	1000.0	-840.4
	2437.0	20.7	118.6	1000.0	-881.4
	2462.0	22.3	169.8	1000.0	-830.2
Wi-fi/g(54Mbit/s)	2412.0	21.2	132.7	1000.0	-867.3
	2437.0	19.2	83.0	1000.0	-917.0
	2462.0	21.8	150.0	1000.0	-850.0
Wi-fi/n(6.5Mbit/s)	2412.0	21.5	140.9	1000.0	-859.1
	2437.0	19.9	98.4	1000.0	-901.6
	2462.0	21.7	149.6	1000.0	-850.4
Wi-fi/n(65Mbit/s)	2412.0	20.2	105.9	1000.0	-894.1
	2437.0	18.3	68.1	1000.0	-931.9
	2462.0	19.7	93.8	1000.0	-906.2

Figure 33 Maximum Peak Power Output

JUDGEMENT: Passed by 830.2 mW

For additional information see *Figure 34* to *Figure 48*.

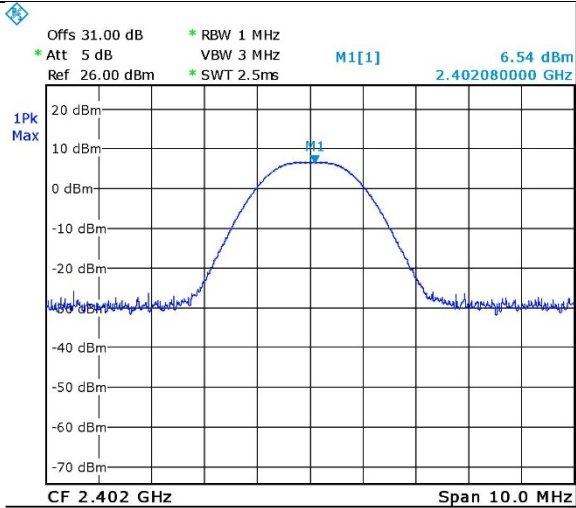

Figure 34. 2402.0 MHz, BLE

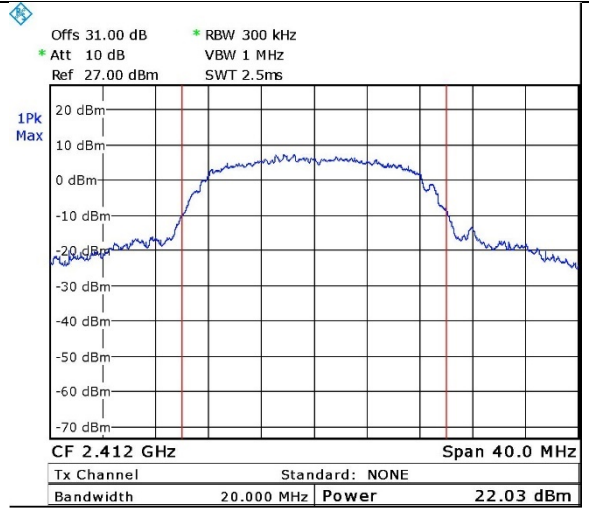

Figure 35. 2412.0 MHz, Wi-fi/g(6Mbit/s)

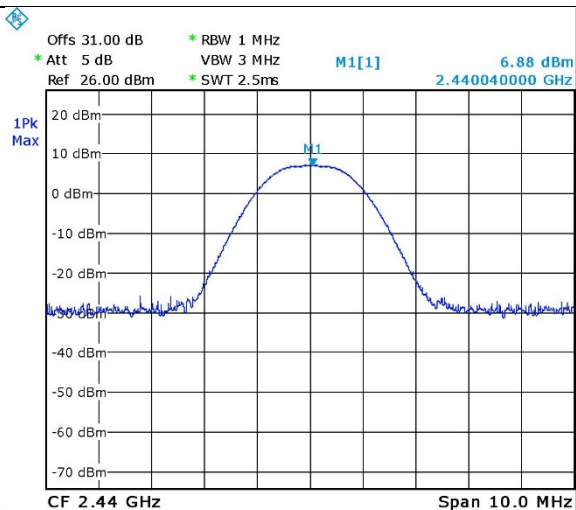

Figure 36. 2440.0 MHz, BLE

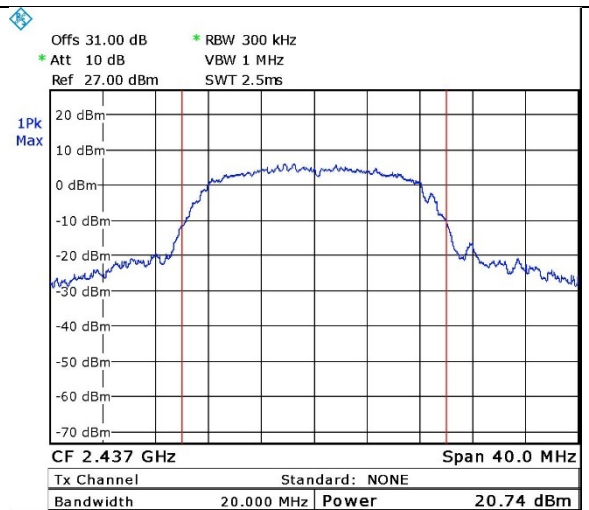

Figure 37. 2437.0 MHz, Wi-fi/g(6Mbit/s)

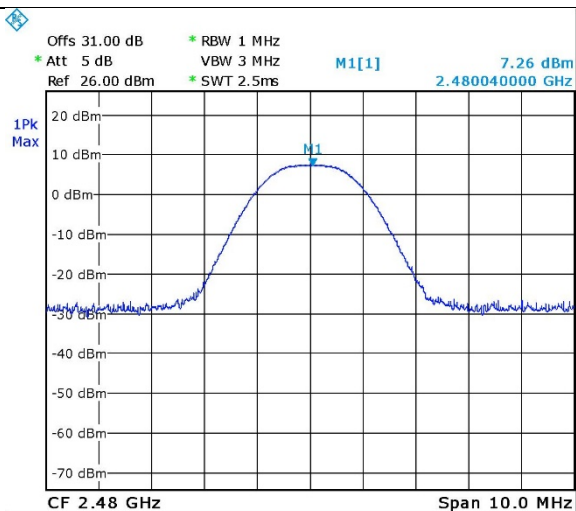

Figure 38. 2480.0 MHz, BLE

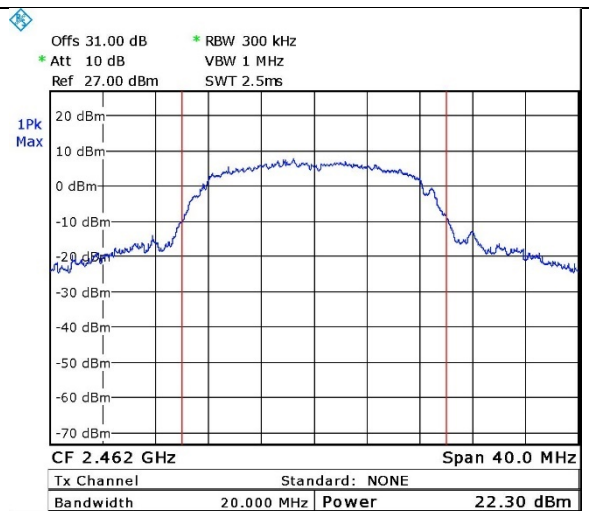

Figure 39. 2462.0 MHz, Wi-fi/g(6Mbit/s)

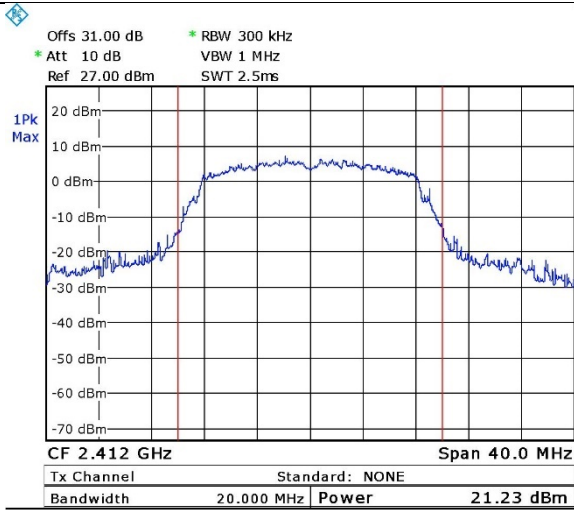

Figure 40. 2412.0 MHz, Wi-fi/g(54Mbit/s)

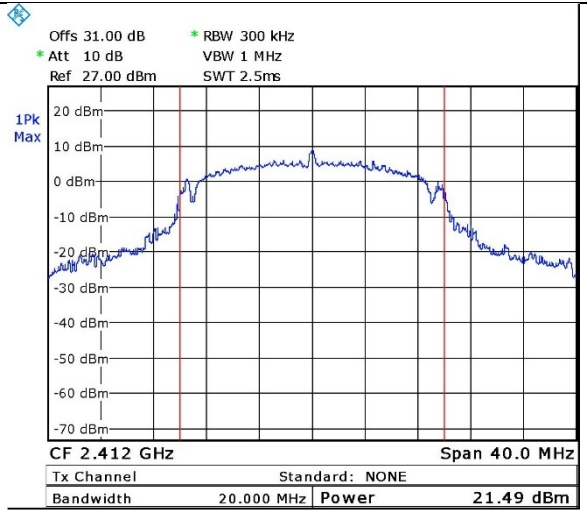

Figure 41. 2412.0 MHz, Wi-fi/n(6.5Mbit/s)

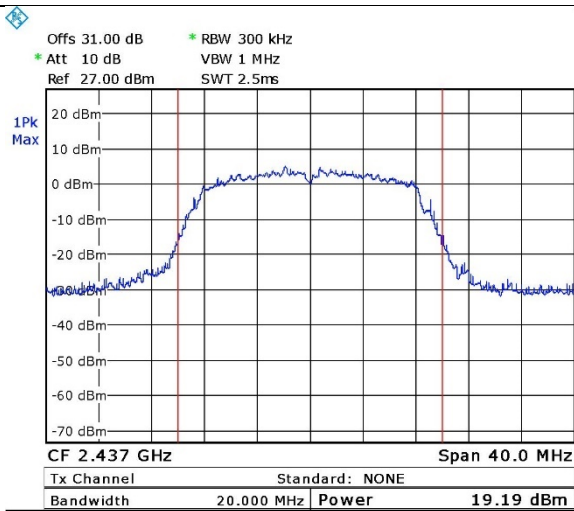

Figure 42. 2437.0 MHz, Wi-fi/g(54Mbit/s)

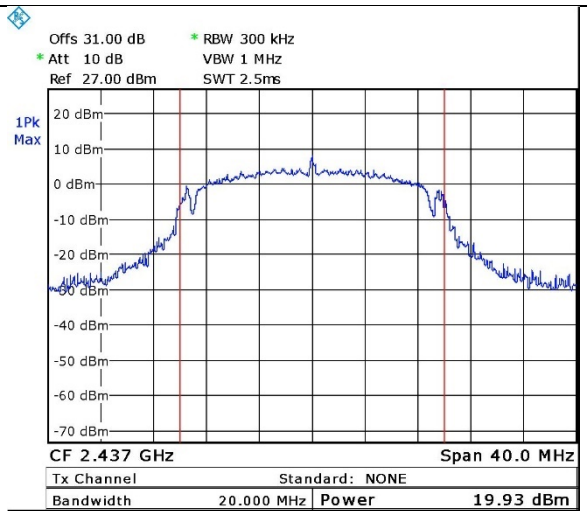

Figure 43. 2437.0 MHz, Wi-fi/n(6.5Mbit/s)

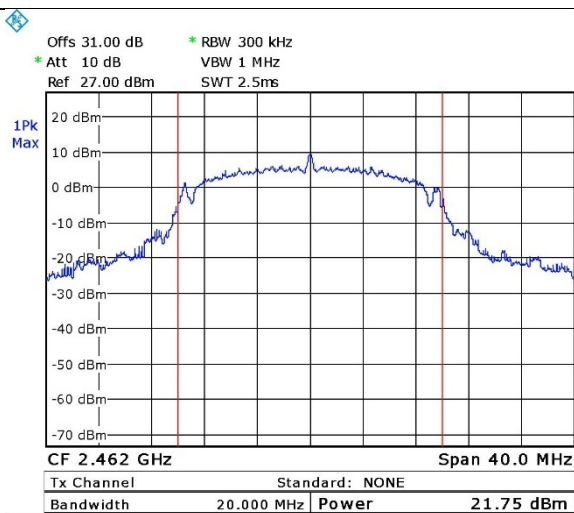

Figure 44. 2462.0 MHz, Wi-fi/g(54Mbit/s)

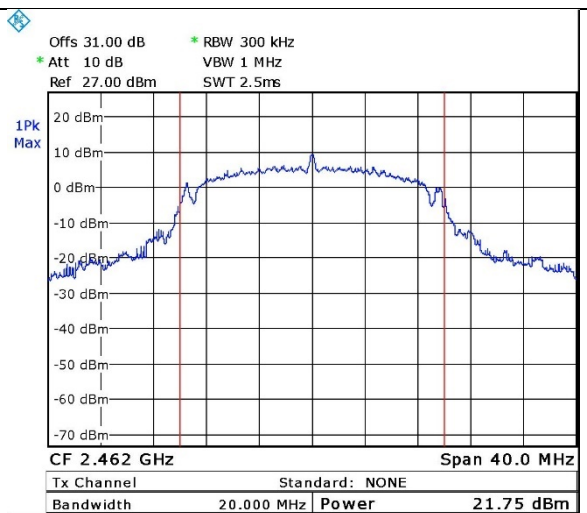

Figure 45. 2462.0 MHz, Wi-fi/n(6.5Mbit/s)

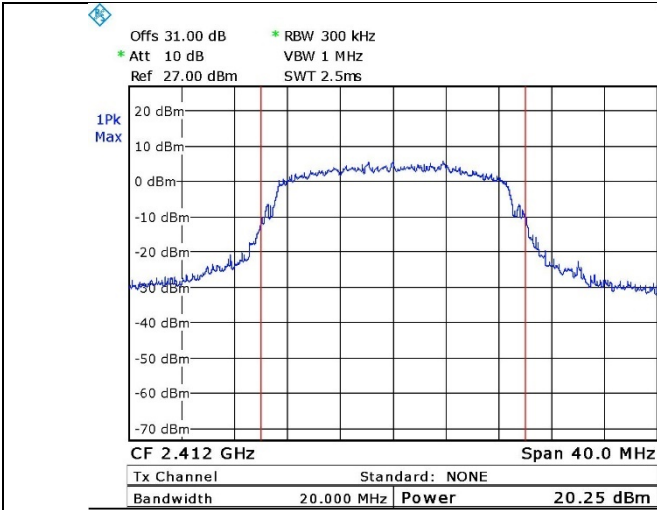

Figure 46. 2412.0 MHz, Wi-fi/n(65Mbit/s)

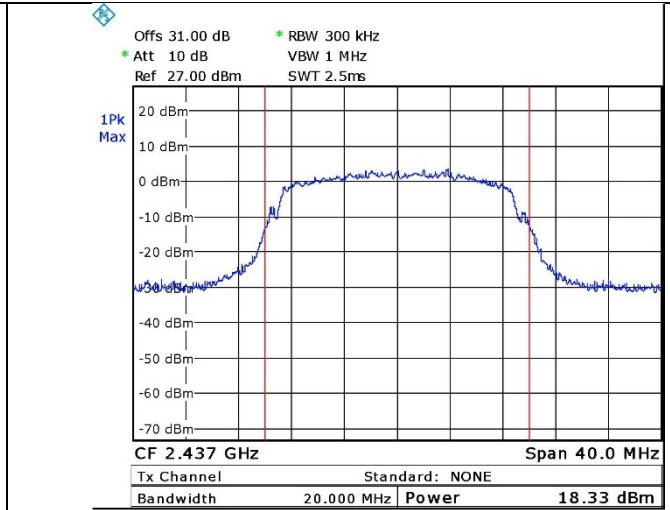

Figure 47. 2437.0 MHz, Wi-fi/n(65Mbit/s)

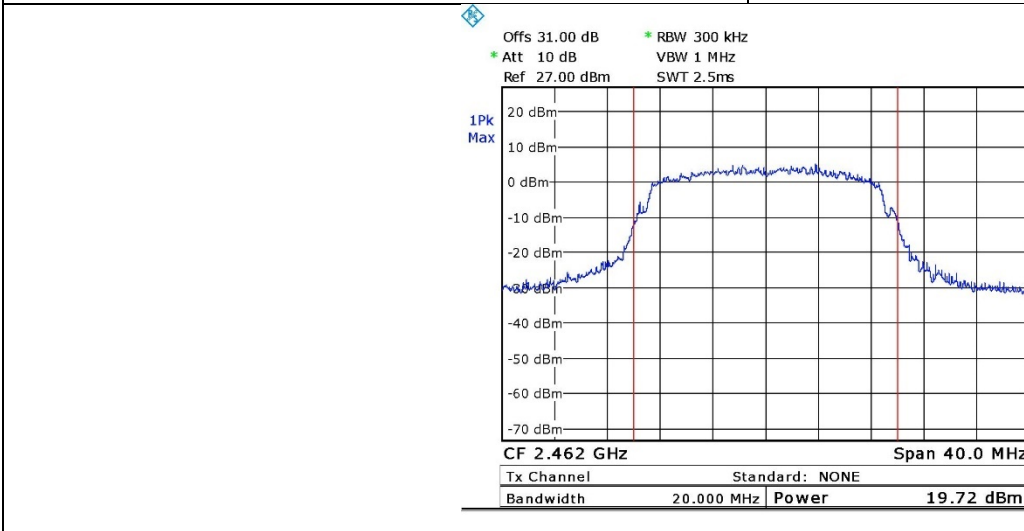

Figure 48. 2462.0 MHz, Wi-fi/n(65Mbit/s)

6.5 Test Equipment Used; Maximum Peak Power Output

Instrument	Manufacturer	Model	Serial No.	Last Calibration Date	Next Calibration Due
Spectrum Analyzer	R&S	FSL6	100194	March 10, 2020	March 31, 2021
30dB Attenuator	MCL	BW-S30W5	533	August 1, 2020	August 31, 2021
RF Cable	Huber Suner	Sucofelex	27502/4PEA	August 1, 2020	August 31, 2021

Figure 49 Test Equipment Used



7. Band Edge Spectrum

7.1 Test Specification

FCC, Part 15, Subpart C, Section 247(d)

7.2 Test Procedure

(Temperature (20°C)/ Humidity (52%RH))

The E.U.T operation mode and test set-up are as described in Section 2 of this report.

The E.U.T. antenna terminal was connected to the Spectrum Analyzer through an external attenuator and an appropriate coaxial cable. Special attention was taken to prevent Spectrum Analyzer RF input overload.

The RBW was set to 100 kHz.

7.3 Test Limit

In any 100 kHz bandwidth outside the frequency band in which the spread spectrum or digitally modulated intentional radiator is operating, the radio frequency power that is produced by the intentional radiator shall be at least 20 dB below that in the 100 kHz bandwidth within the band that contains the highest level of the desired power.

7.4 Test Results

Protocol Type	Operation Frequency	Band Edge Frequency	Spectrum Level	Limit	Margin
	(MHz)	(MHz)	(dBm)	(dBm)	(dB)
BLE	2402.0	2400.0	-42.1	-14.5	-27.6
	2480.0	2483.5	-42.4	-13.8	-28.6
Wi-fi/g(6Mbit/s)	2412.0	2400.0	-24.0	-16.3	-7.7
	2462.0	2483.5	-35.2	-15.7	-19.5
Wi-Fi/g(54Mbit/s)	2412.0	2400.0	-28.5	-16.5	-12.0
	2462.0	2483.5	-35.4	-17.7	-17.7
Wi-Fi/n(6.5Mbit/s)	2412.0	2400.0	-23.8	-16.3	-7.5
	2462.0	2483.5	-34.3	-16.7	-17.6
Wi-fi/n(65Mbit/s)	2412.0	2400.0	-28.9	-17.9	-11.0
	2462.0	2483.5	-40.0	-18.5	-21.5

Figure 50 Band Edge Spectrum

JUDGEMENT: Passed by 7.5 dB

For additional information see *Figure 51* and *Figure 60*.

Band Edge Spectrum

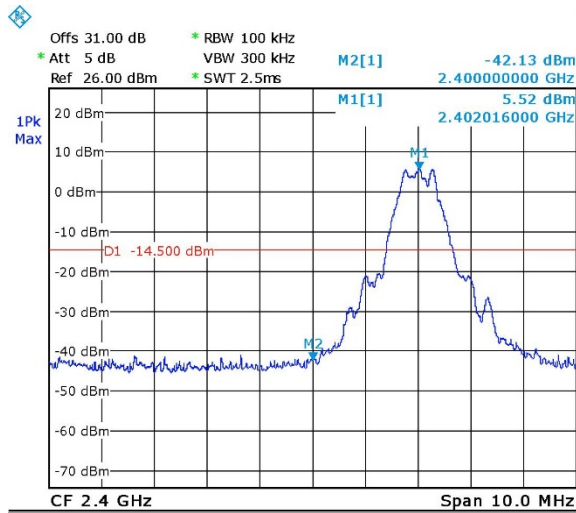

Figure 51 Band Edge Low, BLE

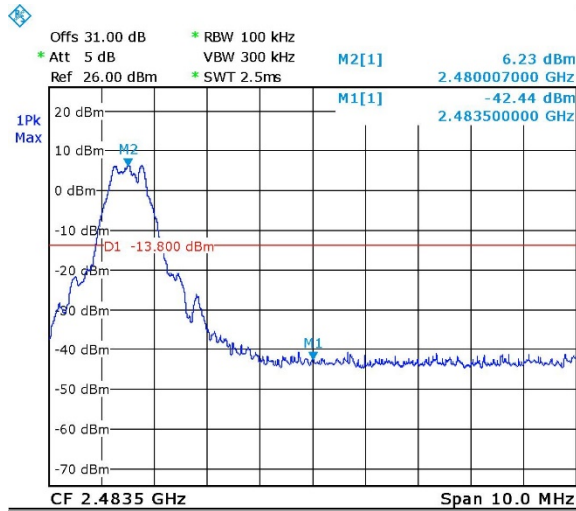

Figure 52 Band Edge High, BLE

Band Edge Spectrum

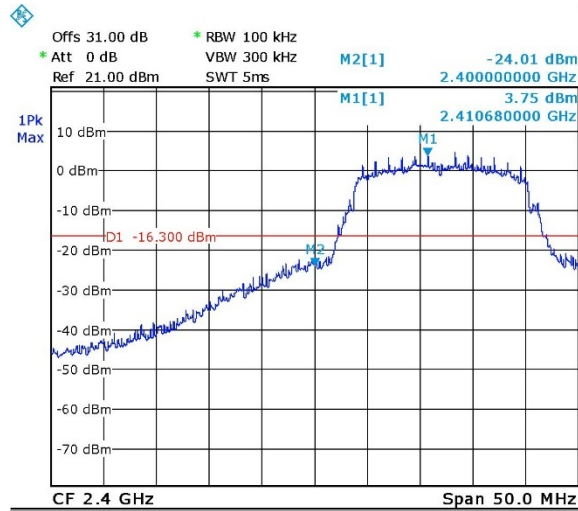

Figure 53 Band Edge Low, Wi-fi/g(6Mbit/s)

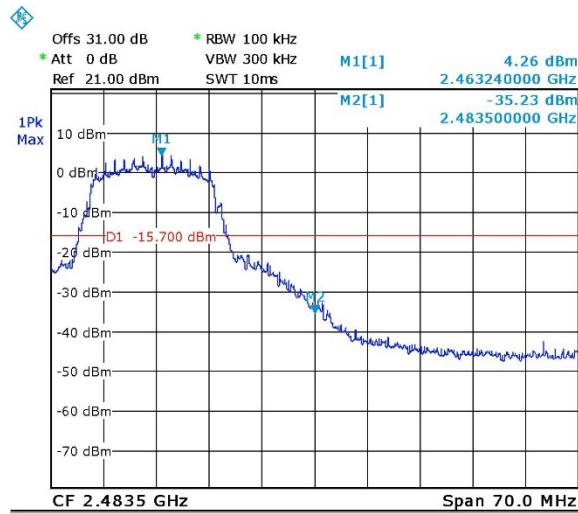

Figure 54 Band Edge High, Wi-fi/g(6Mbit/s)

Band Edge Spectrum

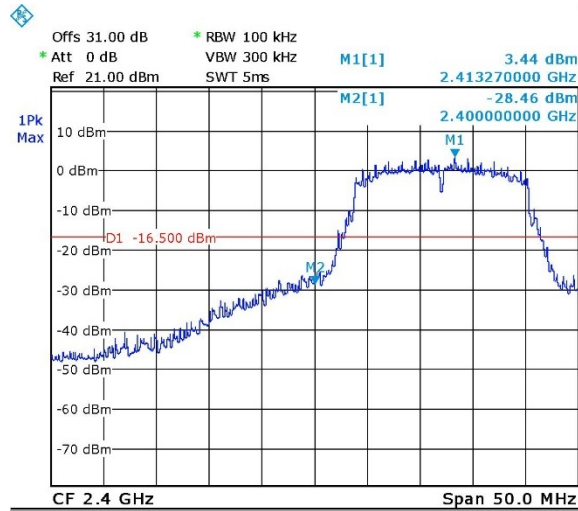

Figure 55 Band Edge Low, Wi-fi/g(54Mbit/s)

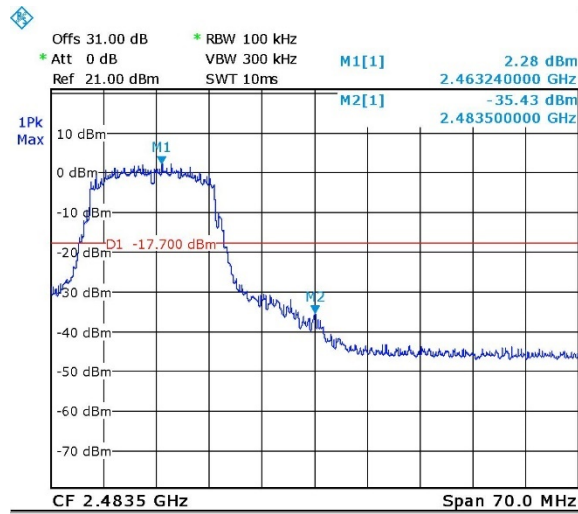

Figure 56 Band Edge High, Wi-fi/g(54Mbit/s)

Band Edge Spectrum

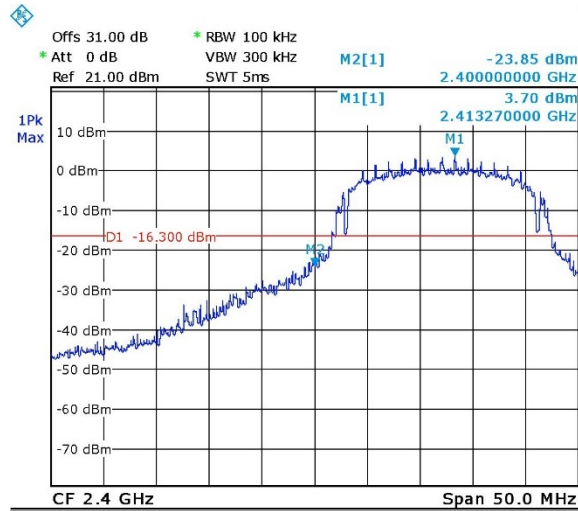

Figure 57 Band Edge Low, Wi-fi/n(6.5Mbit/s)

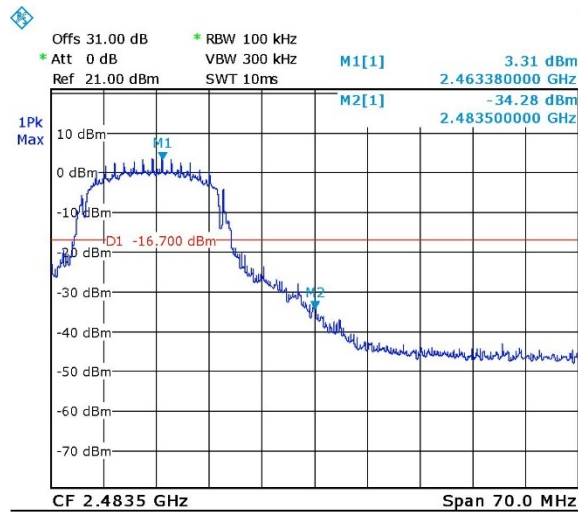

Figure 58 Band Edge High, Wi-fi/n(6.5Mbit/s)

Band Edge Spectrum

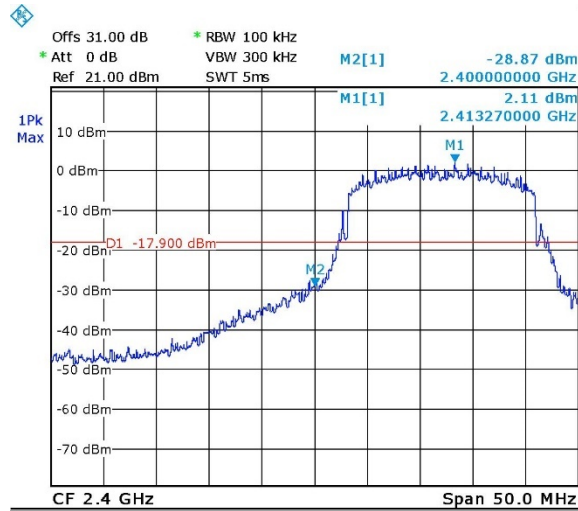

Figure 59 Band Edge Low, Wi-fi/n(65Mbit/s)

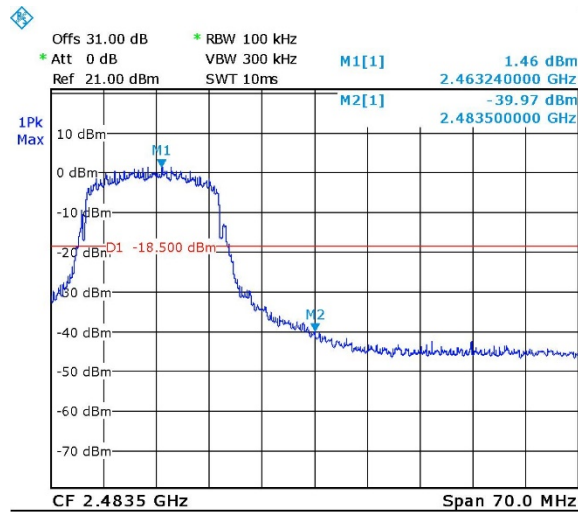

Figure 60 Band Edge High, Wi-fi/n(65Mbit/s)



7.5 Test Equipment Used; Band Edge

Instrument	Manufacturer	Model	Serial No.	Last Calibration Date	Next Calibration Due
Spectrum Analyzer	R&S	FSL6	100194	March 10, 2020	March 31, 2021
30dB Attenuator	MCL	BW-S30W5	533	August 1, 2020	August 31, 2021
RF Cable	Huber Suner	Sucofelex	27502/4PEA	August 1, 2020	August 31, 2021

Figure 61 Test Equipment Used