



FCC Test Report

Applicant : SHENZHEN QIAOHUA INDUSTRIES LIMITED
Address : 301, No.1 Workshop, Longqiaohua Industrial Zone, Luotian Forest Farm, Songgang Street, Baoan District, Shenzhen City, Guangdong, Province, 518105, China
Equipment : Video door phone
Model No. : VP-A, VP-D, VP-L, VP-F
Trade Name : **Quhwa**
FCC ID : 2AAV8VP-736A

I HEREBY CERTIFY THAT :

The sample was received on Jun. 15, 2017 and the testing was carried out on Jul. 03, 2017 at CerpPASS Technology Corp. The test result refers exclusively to the test presented test model / sample. Without written approval of CerpPASS Technology Corp., the test report shall not be reproduced except in full.

Approved by:

Mark Liao
EMC/RF B.U. Manager

Laboratory Accreditation:

CerpPASS Technology Corporation Test Laboratory

TAF LAB Code:	1439
----------------------	-------------

CerpPASS Technology(SuZhou) Co., Ltd.

NVLAP LAB Code:	200814-0
CNAS LAB Code:	L5515



Contents

1. Summary of Test Procedure and Test Results	4
1.1. Applicable Standards	4
2. Test Configuration of Equipment under Test	5
2.1. Feature of Equipment under Test.....	5
2.2. Test Manner	5
2.3. Description of Test System.....	5
2.4. General Information of Test.....	6
2.5. Measurement Uncertainty	6
3. Test Equipment and Ancillaries Used for Tests	7
4. Test of Conducted Emission	8
4.1. Test Limit	8
4.2. Test Procedures	8
4.3. Typical test Setup	9
4.4. Test Result and Data	10
5. Test of Radiated Emission	12
5.1. Test Limit	12
5.2. Test Procedures	13
5.3. Typical Test Setup	13
5.4. Test Result and Data (9kHz~30MHz).....	15
5.5. Test Result and Data ((30MHz ~ 1000MHz)	16
6. Antenna Requirements	18
6.1. Standard Applicable	18
6.2. Limit.....	18
6.3. Antenna Construction.....	18



1. Summary of Test Procedure and Test Results

1.1. Applicable Standards

Test Item	Normative References	Test Result
Conducted Emission	15.207	PASS
Radiated Emission	15.209	PASS
. Antenna Requirement	15.203	PASS



2. Test Configuration of Equipment under Test

2.1. Feature of Equipment under Test

Equipment	Video door phone
Model No.	VP-A, VP-D, VP-L, VP-F
Model Discrepancy	All models are identical to each other except for appearance. Model VP-A is the representative for final test.
Frequency	125KHz
Number of Channel	1 channel
Modulation type	ASK
Antenna type	Integral antenna
Antenna Gain	0dBi (declared by manufacturer)
Power Rating	DC 15V Supplied by adapter

Accessory equipment

Device	Model No.	Description
Monitor	VP-736, VP-645, VP-735, VP-615, VP-732, VP-608	Indoor Unit
Adapter	HS18-1501200US	Input:100-240V~50/60Hz 0.5A Max Output:15.0V  1200mA 1.0m Non Shielding
ID Card	N/A	N/A
DC cable	N/A	15.0m Non Shielding

2.2. Test Manner

- During testing, the interface cables and equipment positions were varied according to ANSI C63.4
- The complete test system included support units and EUT for the RF test
- The test mode was performed for Conducted Emission and Radiated Emission test.

2.3. Description of Test System

Device	Manufacturer	Model No.	Description
DC POWER	LONG WEI	PS-305D	N/A

Use Cable:

No.	Cable	Quantity	Description
A	DC Cable	1	15.0m Non Shielding (Accessory)

**2.4. General Information of Test**

<input checked="" type="checkbox"/>	Test Site	Cerpass Technology Corporation Test Laboratory Address: No.10, Ln. 2, Lianfu St., Luzhu Dist., Taoyuan City 33848, Taiwan (R.O.C.) Tel:+886-3-3226-888 Fax:+886-3-3226-881 Address: No.68-1, Shihbachongsi, Shihding Township, New Taipei City 223, Taiwan, R.O.C. Tel: +886-2-2663-8582
	FCC	TW1079, TW1061,390316, 228391, 641184
	IC	4934E-1, 4934E-2
	VCCI	T-2205 for Telecommunication Test C-4663 for Conducted emission test R-3428, R-4218 for Radiated emission test G-812, G-813 for radiated disturbance above 1GHz
<input type="checkbox"/>	Test Site	Cerpass Technology (Suzhou) Co.,Ltd Address: No.66,Tangzhuang Road, Suzhou Industrial Park, Jiangsu 215006, China Tel: +86-512-6917-5888 Fax: +86-512-6917-5666
	FCC	916572, 331395
	IC	7290A-1, 7290A-2
	VCCI	T-343 for Telecommunication Test C-2919 for Conducted emission test R-2670 for Radiated emission test G-227 for radiated disturbance above 1GHz
Test Distance:		The test distance of radiated emission from antenna to EUT is 3 M.

2.5. Measurement Uncertainty

Test results and Measurement uncertainty without any relationship in the test report.

Measurement Item	Measurement Frequency	Polarization	Uncertainty
Conducted Emission	9 kHz ~ 30 MHz	LINE/NEUTRAL	±2.71 dB
Radiated Emission	30 MHz ~ 25GHz	Vertical	±4.11 dB
		Horizontal	±4.10 dB



3. Test Equipment and Ancillaries Used for Tests

Instrument	Manufacturer	Model No.	Serial No.	Calibration Date	Valid Date
Test Receiver	R&S	ESCI	100564	2017.02.14	2018.02.13
LISN	SCHWARZBEC K	NSLK 8127	8127748	2017.02.14	2018.02.13
LISN	SCHWARZBEC K	NSLK 8127	8127749	2017.02.14	2018.02.13
Pulse Limiter with 10dB Attenuation	SCHWARZBEC K	VTSD 9561-F	9561-F106	2017.02.14	2018.02.13
Temperature/ Humidity Meter	mingle	ETH529	N/A	2017.02.14	2018.02.13
AMPLIFIER	HP	8447F	3113A0591 5	2017.02.14	2018.02.13
Loop Antenna	R&S	HFH2-Z2	100150	2016.10.24	2017.10.23
BILOG Antenna	SCHAFFNER	CBL6112D	22241	2017.02.14	2018.02.13
Horn Antenna	Sunol	DRH-118	A072913	2016.10.12	2017.10.11
Broad-Band Horn Antenna	Schwarzbeck	BBHA9170	9170-347	2017.05.26	2018.05.25
Preamplifier	COM-POWER	PA-840	711885	2017.02.14	2018.02.13
Temp&Humidity& barometer	mingle	ETH529	N/A	2017.02.14	2018.02.13
Preamplifier	Feld	AFS44-00101 800-25- 10P-44	1579008	2016.09.30	2017.09.29
ESG VECTOR SIGNAL GENERATOR	Agilent	E4438C	MY450925 82	2017.05.26	2018.05.25
MXG VECTOR SIGNAL GENERATOR	Agilent	N5182B	MY530501 27	2017.05.26	2018.05.25
EXA Signal Analyzer	Agilent	N9020A	US462202 90	2017.05.26	2018.05.25
Power sensor	e-channel	ERS-180T-24	TW545102 6	2017.05.26	2018.05.25
Series Power Meter	ANRITSU	ML24958A	1224005	2017.02.14	2018.02.13



4. Test of Conducted Emission

4.1. Test Limit

According to 47/CFR15.207.

Frequency (MHz)	Quasi Peak (dB μ V)	Average (dB μ V)
0.15 – 0.5	66-56*	56-46*
0.5 – 5.0	56	46
5.0 – 30.0	60	50

Note:*=Decrease with the logarithm of the frequency

4.2. Test Procedures

- a. The EUT was placed 0.4 meter from the conducting wall of the shielding room was kept at least 80 centimeters from any other grounded conducting surface.
- b. Connect EUT to the power mains through a line impedance stabilization network (LISN).
- c. All the support units are connecting to the other LISN.
- d. The LISN provides 50 ohm coupling impedance for the measuring instrument.
- e. The FCC states that a 50 ohm, 50 micro-Henry LISN should be used.
- f. Both sides of AC line were checked for maximum conducted interference.
- g. The frequency range from 150 kHz to 30 MHz was searched.
- h. Set the test-receiver system to Peak Detect Function and Specified Bandwidth with Maximum Hold Mode.



4.3. Typical test Setup

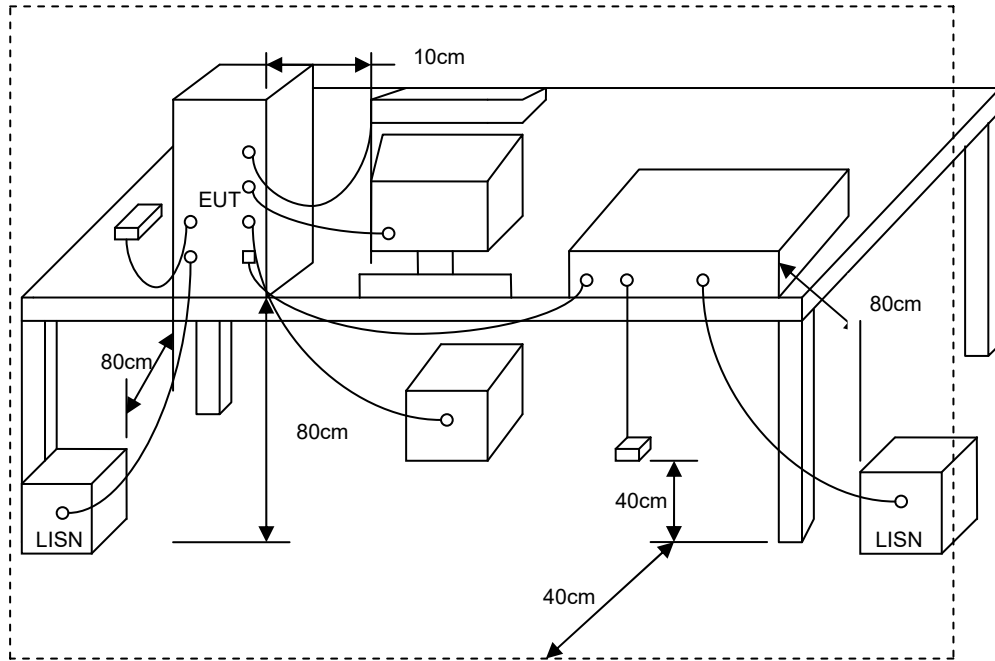



4.4. Test Result and Data

Power	: AC 120V	Pol/Phase	: LINE
Test Mode 1	: Normal link	Temperature	: 20 °C
Test Date	: Jun. 12, 2017	Humidity	: 58 %

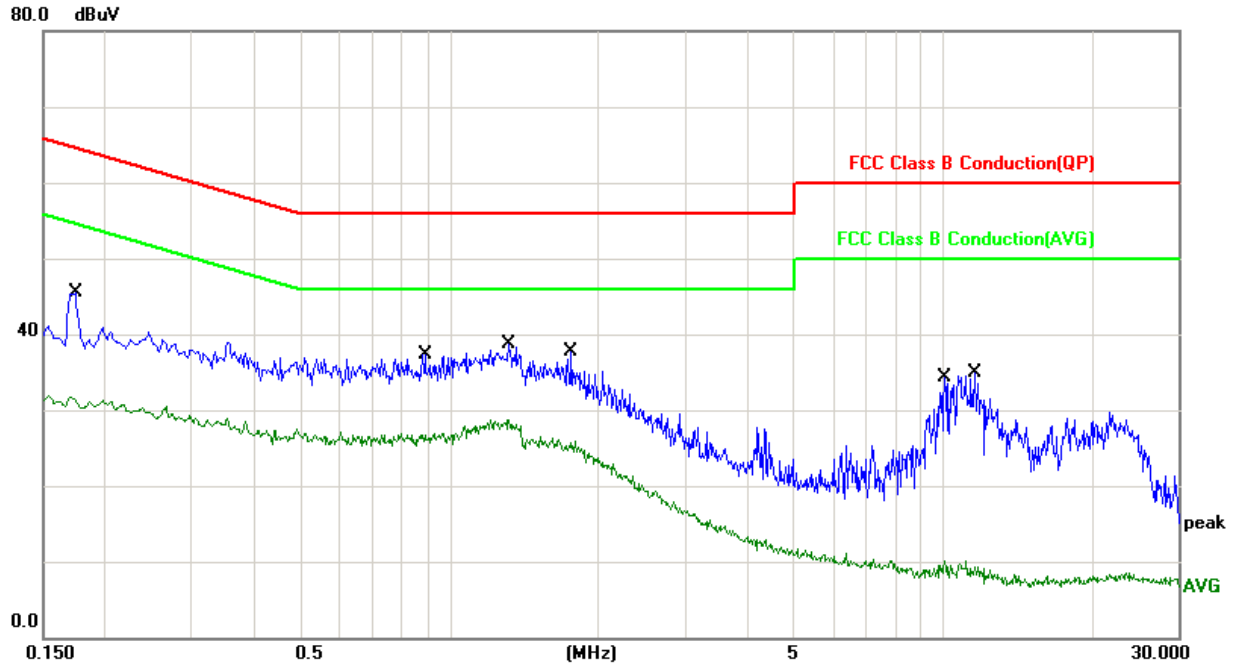

No.	Frequency (MHz)	Factor (dB)	Reading (dBuV)	Level (dBuV)	Limit (dBuV)	Margin (dB)	Detector
1	0.1740	10.06	26.04	36.10	64.76	-28.66	QP
2	0.1740	10.06	20.62	30.68	54.76	-24.08	AVG
3	0.8900	10.11	20.98	31.09	56.00	-24.91	QP
4	0.8900	10.11	15.81	25.92	46.00	-20.08	AVG
5	1.3220	10.43	22.77	33.20	56.00	-22.80	QP
6	1.3220	10.43	17.55	27.98	46.00	-18.02	AVG
7	1.7700	10.84	19.18	30.02	56.00	-25.98	QP
8	1.7700	10.84	14.01	24.85	46.00	-21.15	AVG
9	10.0940	10.27	12.86	23.13	60.00	-36.87	QP
10	10.0940	10.27	-2.77	7.50	50.00	-42.50	AVG
11	11.6100	10.35	10.23	20.58	60.00	-39.42	QP
12	11.6100	10.35	-3.39	6.96	50.00	-43.04	AVG

Note: Level = Reading + Factor
Margin = Level – Limit



Power	: AC 120V	Pol/Phase	: NEUTRAL
Test Mode 1	: Normal link	Temperature	: 20 °C
Test Date	: Jun. 12, 2017	Humidity	: 58 %

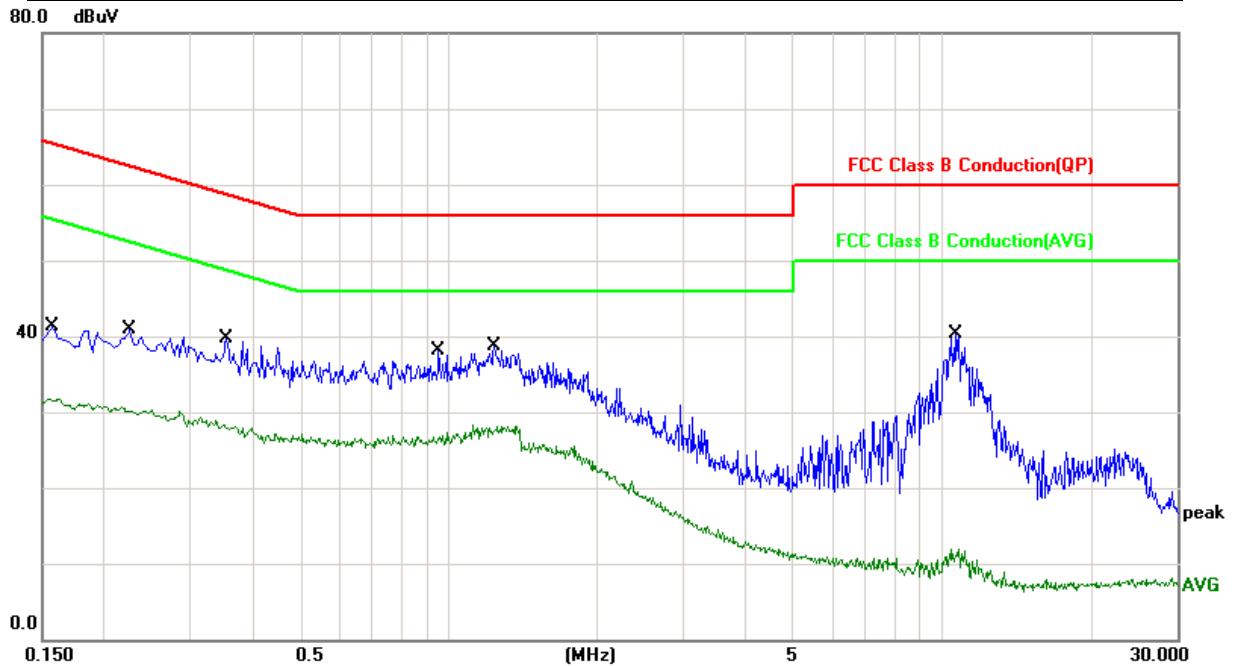

No.	Frequency (MHz)	Factor (dB)	Reading (dBuV)	Level (dBuV)	Limit (dBuV)	Margin (dB)	Detector
1	0.1580	10.06	26.55	36.61	65.56	-28.95	QP
2	0.1580	10.06	21.04	31.10	55.56	-24.46	AVG
3	0.2260	10.05	25.11	35.16	62.59	-27.43	QP
4	0.2260	10.05	19.88	29.93	52.59	-22.66	AVG
5	0.3540	9.97	23.47	33.44	58.87	-25.43	QP
6	0.3540	9.97	18.30	28.27	48.87	-20.60	AVG
7	0.9580	10.12	21.22	31.34	56.00	-24.66	QP
8	0.9580	10.12	16.18	26.30	46.00	-19.70	AVG
9	1.2420	10.14	22.76	32.90	56.00	-23.10	QP
10	1.2420	10.14	17.50	27.64	46.00	-18.36	AVG
11	10.6540	10.30	16.79	27.09	60.00	-32.91	QP
12	10.6540	10.30	-2.63	7.67	50.00	-42.33	AVG

Note: Level = Reading + Factor

Margin = Level – Limit

Test engineer: Amos



5. Test of Radiated Emission

5.1. Test Limit

Radiated emissions from 30 MHz to 25 GHz were measured according to the methods defines in ANSI C63.4. The EUT was placed, 0.8 meter above the ground plane. The interface cables and equipment positions were varied within limits of reasonable applications to determine the positions producing maximum radiated emissions.

According to § 15.209(a), the emissions from an intentional radiator shall not exceed the field strength levels specified in the following table:

FREQUENCIES(MHz)	FIELD STRENGTH(microvolts/meter)	MEASUREMENT DISTANCE(meters)
0.009~0.490	2400/F(kHz)	300
0.490~1.705	24000/F(kHz)	30
1.705~30.0	30	30
30~88	100	3
88~216	150	3
216~960	200	3
Above 960	500	3



5.2. Test Procedures

- a. The EUT was placed on a rotatable table top 0.8 meter above ground.
- b. The EUT was set 3 meters from the interference receiving antenna which was mounted on the top of a variable height antenna tower.
- c. The table was rotated 360 degrees to determine the position of the highest radiation.
- d. The antenna is a broadband antenna and its height is varied between one meter and four meters above ground to find the maximum value of the field strength both horizontal polarization and vertical polarization of the antenna are set to make the measurement.
- e. For each suspected emission the EUT was arranged to its worst case and then tune the antenna tower (from 1 M to 4 M) and turn table (from 0 degree to 360 degrees) to find the maximum reading.
- f. Set the test-receiver system to Peak or CISPR quasi-peak Detect Function and specified bandwidth with Maximum Hold Mode.
- g. If the emission level of the EUT in peak mode was 3 dB lower than the limit specified, then testing will be stopped and peak values of EUT will be reported, otherwise, the emissions which do not have 3 dB margin will be repeated one by one using the quasi-peak method and reported.
- h. For testing above 1GHz, the emission level of the EUT in peak mode was 20dB lower than average limit (that means the emission level in peak mode also complies with the limit in average mode), then testing will be stopped and peak values of EUT will be reported, otherwise, the emissions will be measured in average mode again and reported.

5.3. Typical Test Setup

9kHz~30MHz Test Setup

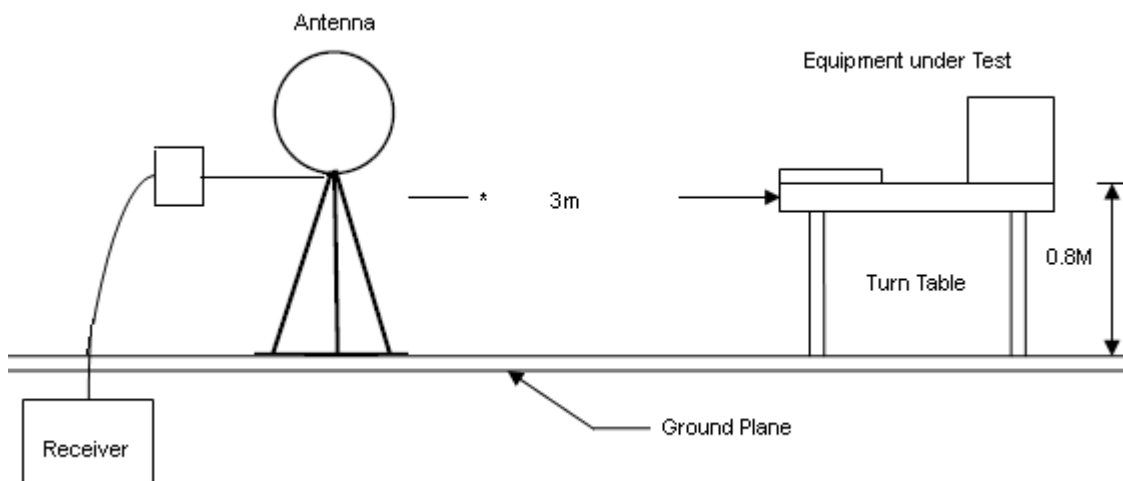



30MHz~1000MHz Test Setup

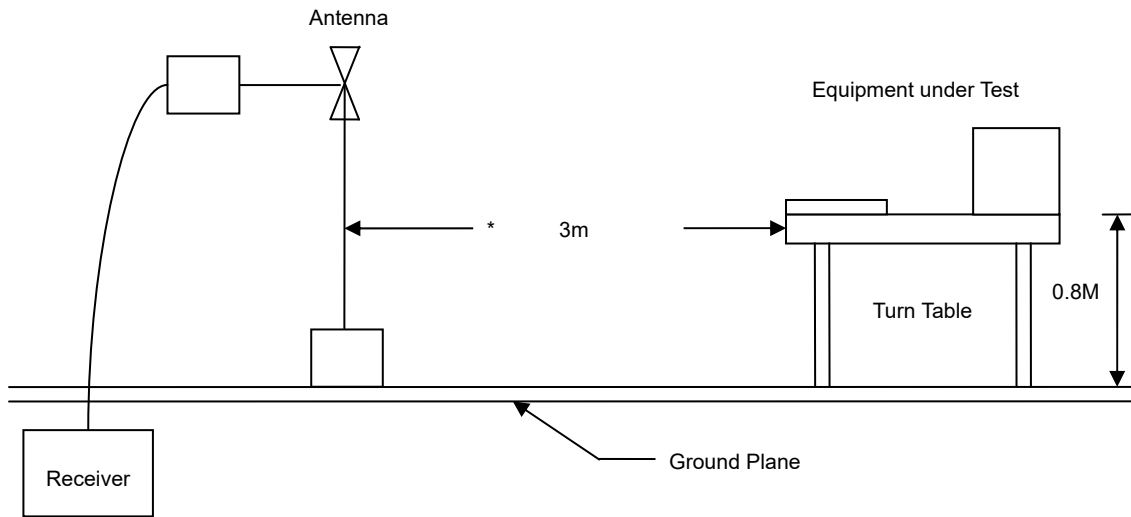



5.4. Test Result and Data (9kHz~30MHz)

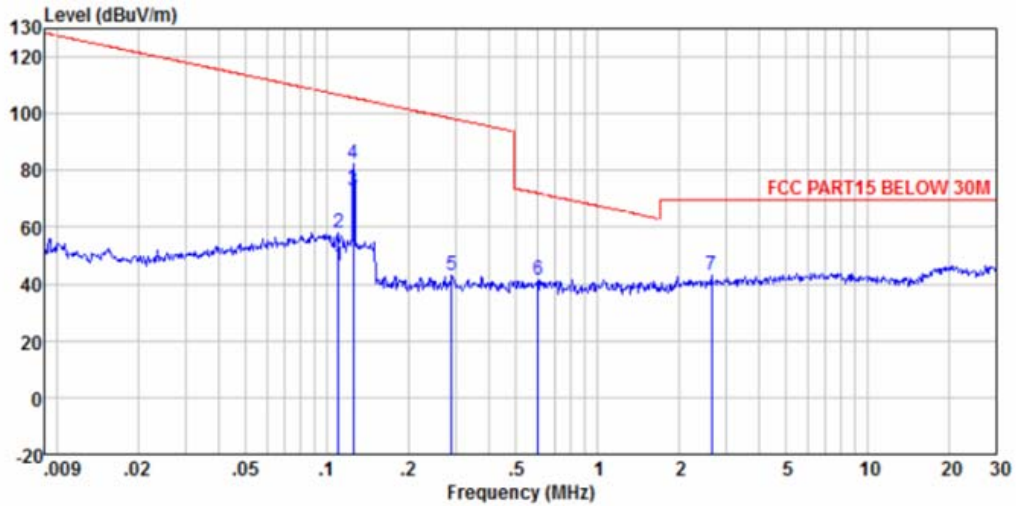

	ReadAntenna	Cable	Limit	Over				
Freq	Level	Factor	Loss	Level	Line	Limit	Remark	
MHz	dBuV	dB/m	dB	dBuV/m	dBuV/m	dB		
1	0.110	21.90	24.12	0.17	46.19	106.78	-60.59	Average
2	0.110	33.61	24.12	0.17	57.90	106.78	-48.88	Peak
3	0.125	49.24	23.64	0.18	73.06	105.66	-32.60	Average
4	0.125	58.31	23.64	0.18	82.13	105.66	-23.53	Peak
5	0.289	21.56	21.49	0.24	43.29	98.38	-55.09	Peak
6	0.604	20.73	20.65	0.29	41.67	71.98	-30.31	Peak
7	2.650	21.91	21.05	0.39	43.35	69.54	-26.19	Peak



5.5. Test Result and Data ((30MHz ~ 1000MHz)

Power	AC 120V	Pol/Phase	HORIZONTAL
Test Mode 1	Normal Link	Temperature	22 °C
Test Date	Jun. 28, 2017	Humidity	68 %

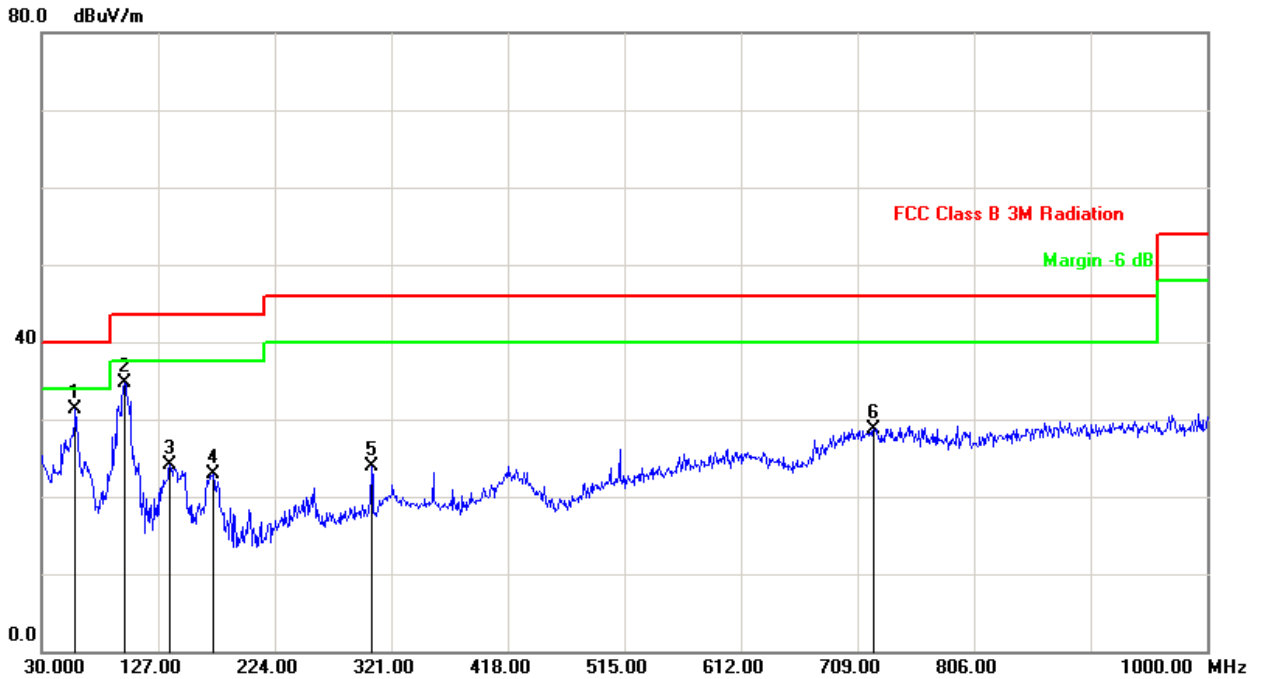

No.	Frequency (MHz)	Factor (dB/m)	Reading (dBuV)	Level (dBuV/m)	Limit (dBuV/m)	Margin (dB)	Det.	Height (cm)	Azimuth (deg)
1	58.1300	-12.35	43.56	31.21	40.00	-8.79	peak	200	110
2	98.8700	-13.06	47.69	34.63	43.50	-8.87	peak	200	142
3	136.7000	-12.83	36.95	24.12	43.50	-19.38	peak	100	271
4	172.5900	-12.59	35.54	22.95	43.50	-20.55	peak	200	166
5	304.5100	-7.82	31.78	23.96	46.00	-22.04	peak	100	164
6	722.5800	1.42	27.38	28.80	46.00	-17.20	peak	100	42

Note: Level = Reading + Factor
Margin = Level – Limit



Power	AC 120V	Pol/Phase	VERTICAL
Test Mode 1	Normal Link	Temperature	22 °C
Test Date	Jun. 28, 2017	Humidity	68 %

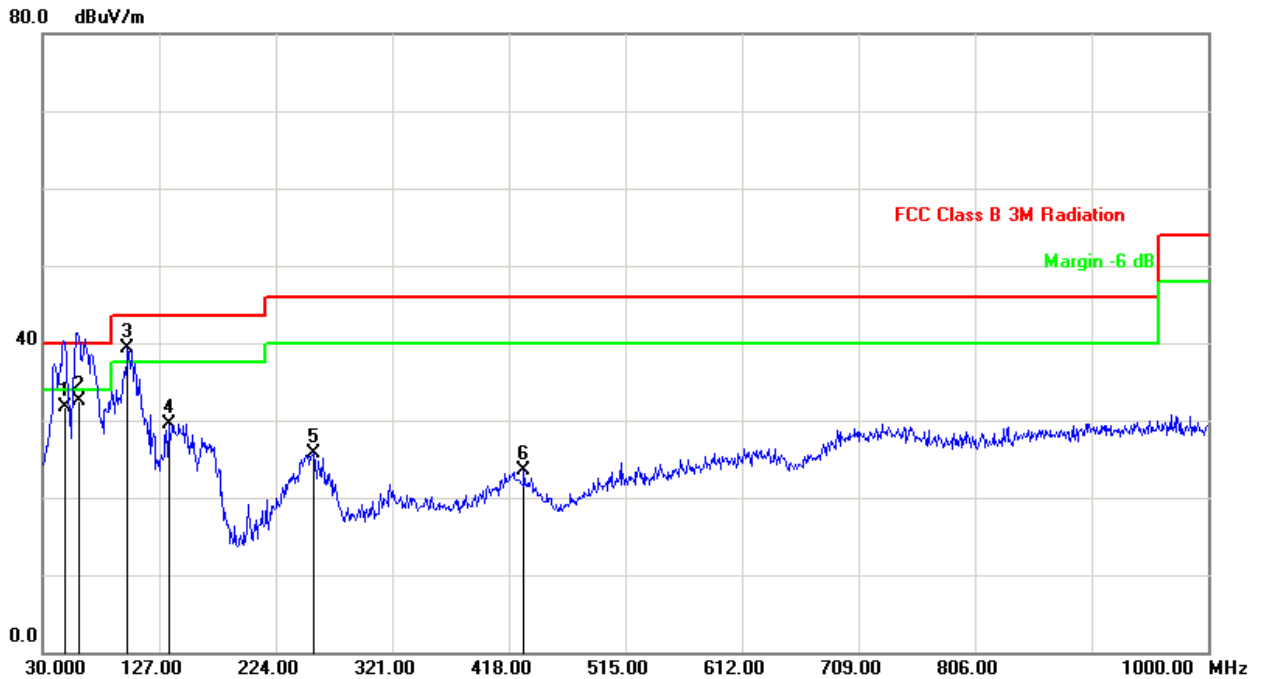

No.	Frequency (MHz)	Factor (dB/m)	Reading (dBUV)	Level (dBUV/m)	Limit (dBUV/m)	Margin (dB)	Det.	Height (cm)	Azimuth (deg)
1	49.0800	-10.54	42.15	31.61	40.00	-8.39	QP	100	301
2	60.6900	-12.73	45.31	32.58	40.00	-7.42	QP	100	125
3	100.8100	-12.79	52.01	39.22	43.50	-4.28	peak	100	175
4	134.7600	-12.83	42.31	29.48	43.50	-14.02	peak	100	164
5	256.0100	-10.50	36.30	25.80	46.00	-20.20	peak	100	255
6	430.6100	-4.41	27.82	23.41	46.00	-22.59	peak	200	351

Note: Level = Reading + Factor
 Margin = Level – Limit



6. Antenna Requirements

6.1. Standard Applicable

For intentional device, according to FCC 47 CFR Section 15.203, an intentional radiator shall be designed to ensure that no antenna other than that furnished by the responsible party shall be used with the device.

And according to FCC 47 CFR Section 15.247 (b), if transmitting antennas of directional gain greater than 6dBi are used, the power shall be reduced by the amount in dB that the directional gain of the antenna exceeds 6dBi.

6.2. Limit

Except for special regulations, the Low-power Radio-frequency Devices must not be equipped with any jacket for installing an antenna with extension cable. An intentional radiator shall be designed to ensure that no antenna other than that furnished by the responsible party shall be used with the device. The use of a permanently attached antenna or of an antenna that uses a unique coupling to the intentional radiator shall be considered sufficient to comply with the provisions of this Section. The manufacturer may design the unit so that the user can replace a broken antenna, but the use of a standard antenna jack or electrical connector is prohibited.

6.3. Antenna Construction

The antenna is Integral Antenna. The antenna gain is 0dBi Max.