

- Model No.: **QH-9839A**  
(Receiver Only)
- Model No.: **QK-P11**  
(Solar Sensor Only)
- Model No.: **QH-9839A-1**
- Model No.: **QH-9839A-2**
- Model No.: **QH-9839A-3**
- Model No.: **QH-9839A-4**

## Wireless Driveway Alert Alarm Kit

### Instruction Manual

Thank you for purchasing the Wireless Microwave Driveway Alarm. Please read the manual for safe operation. Check the FAQ card for answers to common questions, and contact customer service if needed.

### 1. Parts Names

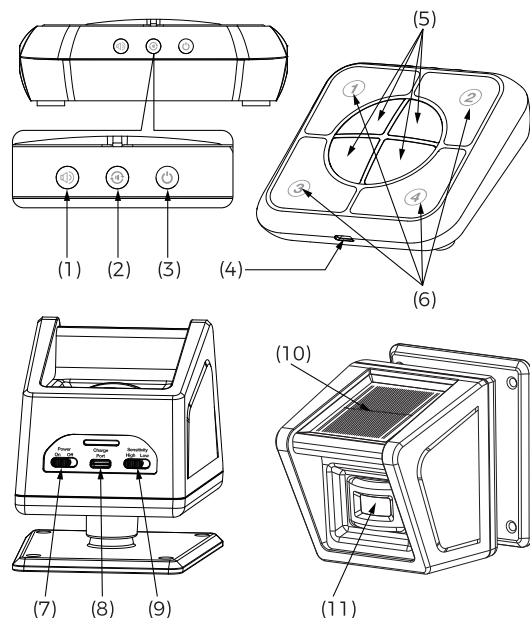

- 01 -

1. Volume Button
2. Alarm Mode Switch Button
3. Receiver ON/OFF Button
4. DC Power Supply Port
5. Alert Zone LED Indicator
6. Touch Button for each Alert Zone (1, 2, 3, 4)
7. Sensor ON/OFF Button
8. Charging Port
9. Sensitivity Adjust Button
10. Solar Panel
11. Sensor Window

### 2. Getting Started

#### 2.1 Powering the Receiver

To power the receiver, you can either use 3 AA batteries or a DC 5V power adapter (not included). Follow these steps to insert batteries:

- Remove the battery compartment cover from the back of the receiver.
- Insert 3 AA batteries into the compartment, ensuring correct polarity to avoid fire hazards.
- Replace the battery compartment cover.

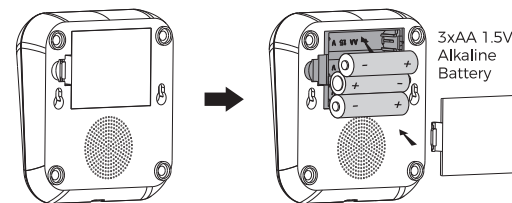

- 02 -

If you prefer using a power adapter, follow these steps:

- Insert the adapter plug into the DC power port at the bottom of the receiver.
- Plug the adapter into a power outlet.

The power adapter specifications are as follows:

**Input: 110-120V for the United States, 220-240V for the European Union.**

**Output: DC 5V-1A (refer to the adapter's rated value label).**

**Remember, the receiver does not support rechargeable lithium batteries. When using the power adapter, remove all batteries from the receiver.**

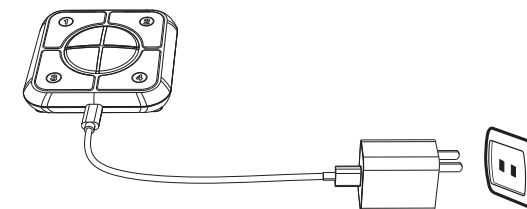

#### 2.2 Powering the Solar Sensor

The solar panel on the sensor absorbs sunlight to charge its built-in rechargeable battery. Before use, ensure the sensor is fully charged. Connect a power adapter (sold separately) to the charging port on the sensor and plug it into a power outlet. Charging usually takes 6-8 hours.

- 03 -

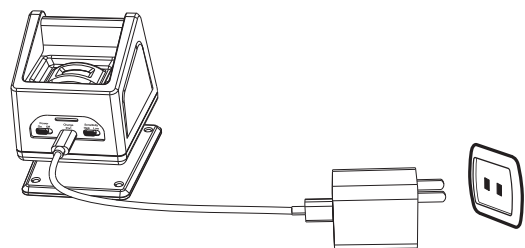

#### Important Notes:

- For optimal lighting performance, ensure the solar sensor receives ample sunlight during charging.
- The solar panel's power generation depends on factors like sunlight intensity, location, weather, season, and environment.
- In cold or cloudy conditions with limited sunlight, the sensor may require additional charging time (at least 6-8 hours).
- If the solar sensor won't receive sunlight for 15 days or more, turn it off and fully charge it using the power adapter.

- 04 -

#### 2.3 Pairing the Solar Sensor with the Receiver

- Step 1: Activate pairing mode on the receiver  
Press the power button to activate the receiver. Touch the alarm zone button corresponding to the desired zone for pairing (e.g., Alarm Zone 1). The LED for the chosen zone will light up, and a beep will sound, indicating pairing mode.

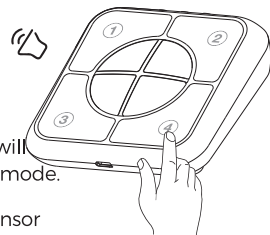

- Step 2: Power on the sensor

Ensure the sensor is powered on by sliding the ON/OFF switch to ON. The sensor window will display a blue LED, indicating readiness for pairing.

Place the solar sensor and receiver close to each other for automatic pairing and connection establishment.

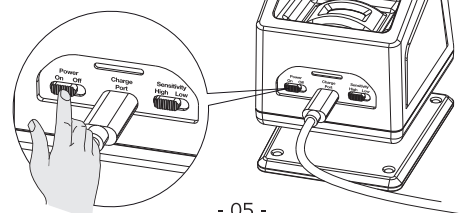

- 05 -

- Step 3: Successfully pair the receiver and sensor

After activating pairing mode and ensuring proximity, wait for approximately 2 seconds. The receiver will emit a specific ringtone for the selected alarm zone, confirming successful pairing. At the end of the pairing mode, the receiver will emit two consecutive beeps.

To confirm the pairing, turn off the sensor and restart it. If the connection is successful, the receiver will emit the same ringtone, and the LED for the paired alarm zone will flash.

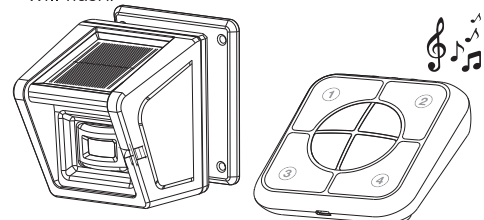

- Step 4: Pairing a receiver with multiple sensors

To pair a receiver with multiple sensors, select other alarm zones on the receiver and repeat the three steps.

- 06 -

#### Tips:

- The receiver's pairing mode remains active for 10 seconds after a beep. Ensure each sensor activates within 10 seconds of pressing the pairing button. Two beeps indicate the pairing mode has stopped. If you don't hear a melody or hear two beeps, repeat the pairing process.
- Each solar sensor can only be paired with one alarm zone at a time.
- In one alert zone, a receiver can be paired with a maximum of 4 sensors. With 4 alert zones per receiver, this means a total of 16 sensors can be paired.

#### 2.4 Ringtone Selection Guide:

- Choose from 30 distinct ringtones to easily identify alarm zones.
- Avoid using the same ringtone for all zones to ensure clear alarm notification.

To Set a Ringtone:

- Double-click touch button (like 1, 2, 3, 4) on the desired panel area to enter the ringtone selection mode, indicated by a 'beep' sound and a flashing blue LED light.
- Use the "volume button" to select your preferred ringtone.
- Confirm your selection by click the touch button again. The device will confirm with a 'beep' followed by playing the selected ringtone.

- 07 -

### 3. Installing the Solar Sensor

#### • Step 1: Mounting the Sensor

Choose a suitable location to mount the sensor vertically, preferably at a height of 3-5 feet (approximately 1-1.5 meters) above the ground. Ensure that the surface is solid, such as a wall, wooden post, or tree. Position the sensor window to face the desired coverage area, such as the driveway or entrance.

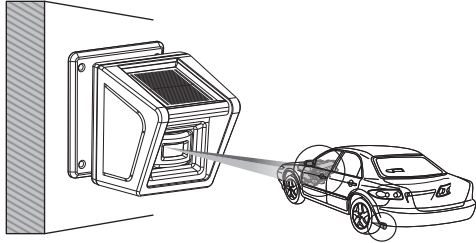

#### • Step 2: Adjusting Sensitivity

Open the black silicone sealing cap located on the bottom of the sensor. Inside, you will find a sensitivity adjustment switch. You can set the sensitivity to either high or low, depending on your specific requirements. "High" Sensitivity provides a detection range (23-32 feet), while "Low" Sensitivity has a smaller range (13-23 feet).

- 08 -

#### • Step 3: Mounting the Sensor Base

Attach the sensor mounting base to the chosen surface using the screws provided with the sensor. Ensure that the base is securely fastened, but avoid over-tightening the screws as it may damage the sensor or mounting surface.

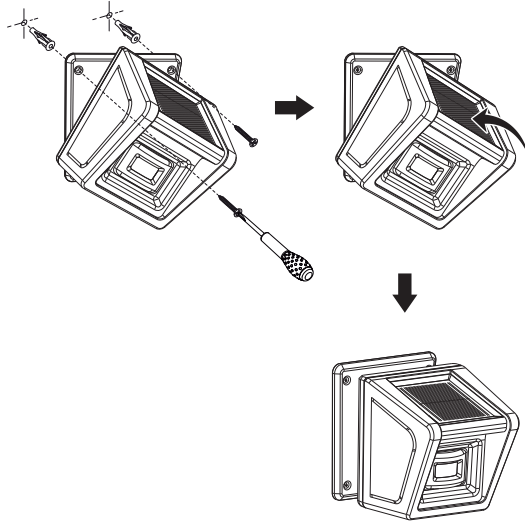

- 09 -

#### • Step 4: Adjusting Sensor Orientation

Position the sensor to effectively cover the desired sensing area. Adjust its position to optimize the detection range and ensure it captures the intended monitoring area.

#### Please note the following while setting up the solar

##### sensor:

- Adjust the direction of the solar panel to face direct sunlight, maximizing its exposure for optimal charging and lighting performance.
- Point the sensor towards an open area, avoiding direct positioning towards trees or bushes. Clear line-of-sight to the desired monitoring area will improve detection accuracy.

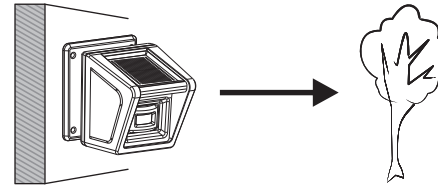

- 10 -

- Tilt the solar sensor slightly downward to avoid angling it upward, which may interfere with its detection capabilities.

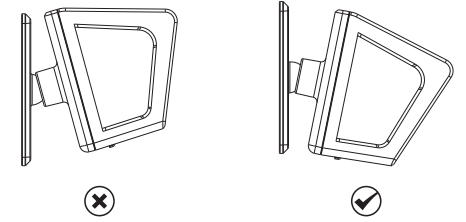

- The working transmission distance between the receiver and solar sensor is approximately **1/2 mile (600 meters)** without obstructions. However, obstacles like buildings or large bushes may affect the transmission range. It is recommended to test the working distance between the receiver and sensor before final installation to ensure reliable communication.

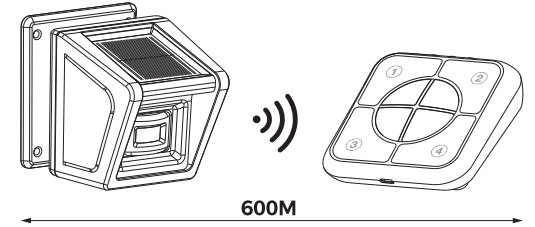

- 11 -

### 4. Receiver Button Description

- **Power Button:** Pressing this button will emit two different sounds to indicate the power state of the receiver. **A single "beep"** signifies that the receiver is **starting up**, while **three consecutive "beeps"** indicate that the receiver is **shutting down**.
- **Alarm Mode Switch Button:** Pressing this button allows you to switch between alarm modes on the receiver. The default mode combines flashing lights and ringing. If you find the ringing sound bothersome, you can press this button to switch to flashing lights only.
- **Volume Button:** The receiver offers six levels of volume. Each press of this button adjusts the volume level. Use it to set the desired volume based on your preference or environmental requirements.

### 5. Solar Sensor Low Battery Alert

When the solar sensor's battery level is low, the Alert Zone Red LED on the receiver will flash, indicating that attention is required for the sensor's battery. To address this, recharge the sensor or relocate it to a sunnier area. Once the sensor is charged, the receiver's alert red LED will turn off.

- 12 -

### 6. Specifications

#### Receiver:

- Power supply: DC 4.5V (3 x AA batteries or by an adapter)
- Wireless frequency: 868MHz ± 20KHz
- Operating range: 1/3 mile (without obstacles)
- Receiver's ring volume: Over >80dB within 0.5m/1.6ft
- Working temperature: -4°F to 131°F

#### Solar Sensor:

- Solar panel: <0.5W
- Li-ion battery: 1200mAh
- Detecting distance: up to 30ft
- Detecting angle: 180 degrees
- Working temperature: -4°F to 131°F
- Waterproofing: IP65

### 7. Warranty and Customer Service

• **30-DAY MONEY BACK GUARANTEE:** If you are not satisfied with your purchase within 30 days, you can request a refund.

• **90-DAY REPLACEMENT/REFUND FOR QUALITY ISSUES:** If there are any quality-related problems within 90 days of purchase, caused by abnormal use or maintenance, you can request a replacement or refund. Report the issue to our customer service department to discuss the process.

• **12 MONTHS WARRANTY ON QUALITY ISSUES:** The Wireless Microwave Driveway Alarm is covered by a

- 13 -

12-month warranty for quality-related issues. If the product is damaged due to normal use within this warranty period, it can be replaced free of charge. Contact our customer service team to make a warranty claim.

• **PLEASE NOTE:** The warranty does not cover product damage resulting from misuse or improper maintenance. Follow the provided instructions for proper operation and maintenance to avoid voiding the warranty.

If you need assistance or encounter any problems, please reach out to our customer service team. They are dedicated to providing prompt support and will respond to your inquiries within 24 hours.

### Product Disposal



Do not dispose of this product in regular household waste. This product falls under the regulations of European Directive 2012/19/EU.

Dispose of this product through an approved disposal company or your local waste facility. Please adhere to the current regulations in your area.

For further information, contact your waste disposal center.



The packaging of this product is made from environmentally friendly materials and can be recycled at your local recycling facility.

- 14 -

This equipment has been tested and found to comply with the limits for a Class B digital device, pursuant to part 15 of the FCC Rules. These limits are designed to provide reasonable protection against harmful interference in a residential installation. This equipment generates, uses and can radiate radio frequency energy and, if not installed and used in accordance with the instructions, may cause harmful interference to radio communications. However, there is no guarantee that interference will not occur in a particular installation. If this equipment does cause harmful interference to radio or television reception, which can be determined by turning the equipment off and on, the user is encouraged to try to correct the interference by one or more of the following measures:

- Reorient or relocate the receiving antenna.
- Increase the separation between the equipment and receiver.
- Connect the equipment into an outlet on a circuit different from that to which the receiver is connected.
- Consult the dealer or an experienced radio/TV technician for help.

This device complies with part 15 of the FCC Rules. Operation is subject to the following two conditions:

- (1) This device may not cause harmful interference, and
- (2) this device must accept any interference received, including interference that may cause undesired operation.

When using the product, maintain a distance of 20cm from the body to ensure compliance with RF exposure requirements.

**Warning:** Changes or modifications not expressly approved by the party responsible for compliance could void the user's authority to operate the equipment.

- 15 -

4 x 2  
A

# 折页要求

1

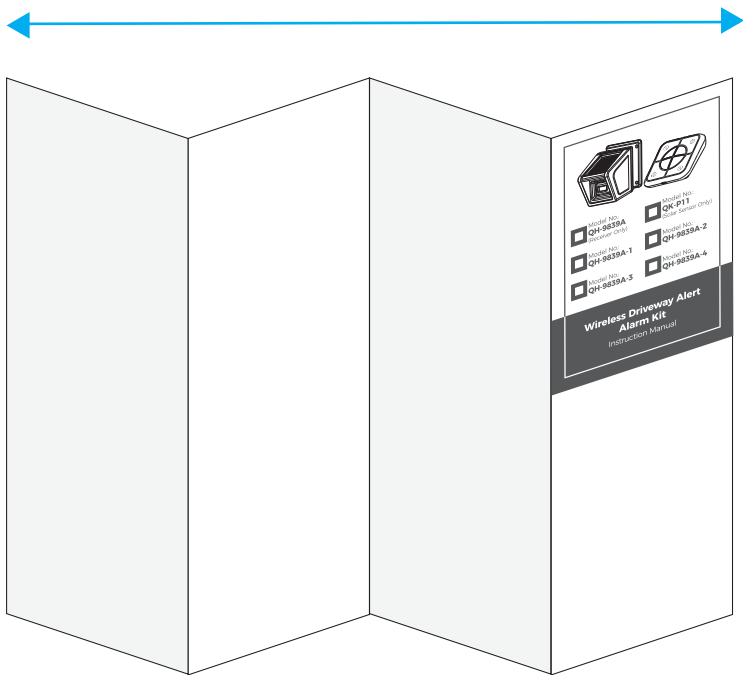

B

2

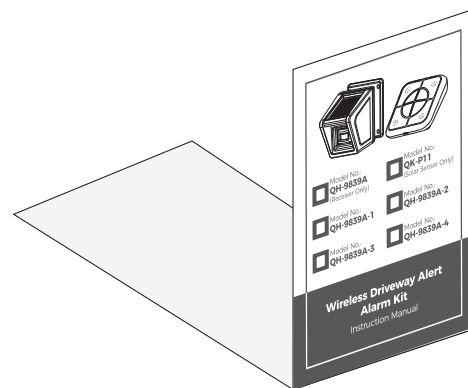

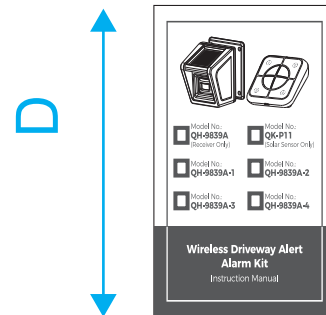

3

C



D

  
Model No. QH-9839A (Receiver Only)  
Model No. QH-9839A-1  
Model No. QH-9839A-3  
Model No. QK-P11 (Data Sensor Only)  
Model No. QH-9839A-2  
Model No. QH-9839A-4  
**Wireless Driveway Alert Alarm Kit**  
Instruction Manual

  
Model No. QK-P11 (Data Sensor Only)  
Model No. QH-9839A-2  
Model No. QH-9839A-1  
Model No. QH-9839A-3  
Model No. QH-9839A-4  
**Wireless Driveway Alert Alarm Kit**  
Instruction Manual

  
Model No. QH-9839A (Receiver Only)  
Model No. QK-P11 (Data Sensor Only)  
Model No. QH-9839A-1  
Model No. QH-9839A-2  
Model No. QH-9839A-3  
Model No. QH-9839A-4  
**Wireless Driveway Alert Alarm Kit**  
Instruction Manual