



Mesh Networking Module  
(IEEE 802.15.4)  
CTL3212

CONFIDENTIAL

All information and data contained in this datasheet are subject to change without notice. This publication supersedes and replaces all information previously supplied. Computime has no responsibility to the consequence of using the information described in this document.

**Revision**

Rev.	Date (DD-MM- YYYY)	History
1	11-14-2019	First Released

CONFIDENTIAL

## Table of Contents

1.	General Description.....	1
2.	Applications .....	1
3.	Features .....	1
4.	Absolute Maximum Ratings.....	2
5.	Recommended Operating Conditions .....	2
6.	Electrical Specifications.....	2
7.	Typical application block.....	3
8.	Pin Assignment .....	4
9.	Pin Description .....	4
10.	Block Diagram .....	10
11.	RF Frequency Detail.....	10
12.	PCB Layout Recommendations .....	11
13.	Antenna test .....	12
14.	Mechanical Dimensions.....	15
15.	Regulatory Statements.....	17

## Mesh Networking Module CTL3212

---

### 1. General Description

The Module (CTL3212) is a fully-integrated, pre-certified module, enabling rapid development of wireless mesh networking solutions.

Based on the Silicon Labs EFR32™ Mighty Gecko SoC, the CTL3212 combines an energy-efficient, multi-protocol wireless SoC with a proven RF/antenna design and industry leading wireless software stacks. This integration accelerates time-to-market and saves months of engineering effort and development costs.

The size of CTL3212 is 22x13x2.6mm. It integrated a 2.4GHz, IEEE 802.15.4-2003 compliant transceiver with a 32-bit network processor (ARM Cortex-M4 Processor) .It contains embedded FLASH and integrated RAM for program and data storage.

CTPN	Description
WIPM0RCTL3212-01	MANUA ASSEMBLY CTL3212 ROHS

### 2. Applications

Home automation & building control



Home appliances & alarms



Monitoring of remote systems



Security systems & lighting controls



Sensor data capture in embedded networks



### 3. Features

- Complete ZigBee-ready module with integrated PCB antenna
- Integrated IEEE 802.15.4 PHY and MAC layer
- SPI /UART interface for communication and controlled by the Host using the EmberZNet Serial Protocol (EZSP)
- On Board oscillator
- High performance direct sequence spread spectrum (DSSS-OQPSK) RF transceiver
- 16 channels in the 2.4 GHz ISM band
- On-chip regulator for 1.8-3.8V operation.
- Three deep low power modes
- 32-bit ARM® Cortex™-M4 processor
- 512KB FLASH ROM and 64KB RAM(EFR32 internal memory)
- +19dBm /+10dBm Max. transmission power
- -99 dBm sensitivity (typ)
- Small footprint: 22x13x2.6mm
- Extremely low Deep Sleep Current.

#### 4. Absolute Maximum Ratings

Parameter	Test Conditions	Min.	Max.	Unit
Voltage on any supply pin		-0.3	+3.8	V
DC voltage on any GPIO pin		-0.3	IOVD D+0.3	V
Voltage on HFXO pins		-0.3	1.4	V
Storage temperature		-40	+85	°C

#### 5. Recommended Operating Conditions

Parameter	Test Conditions	Min.	Typ.	Max.	Unit
Regulator input voltage (VDD_PADS)		1.8		3.8	V
Operating temperature range		-10		+55	°C
Moisture Sensitivity Level(MSL)		MSL3			

#### 6. Electrical Specifications

T=25°C, VCC = 3.3V, Fo =2450MHz, if nothing else stated.

Parameter	Condition / Note	Min	Typ.	Max	Unit
RF Operating frequency	Programmable in 5MHz steps, 5 MHz steps for IEEE 802.15.4 compliance	2.4		2.5	GHz
Number of channels	For IEEE 802.15.4 compliance		16		
Channel spacing	For IEEE 802.15.4 compliance		5		MHz
Frequency stability				+/-40	ppm
Transmit power	Programmable from firmware			+19	dBm
Sensitivity	PER 1% , 250 kbps DSSS-OQPSK signal		-99		dBm
Adjacent channel rejection +/-5 MHz	IEEE 802.15.4 compliance at -82 dBm		40/40		dB
Adjacent channel rejection +/-10 MHz	IEEE 802.15.4 compliance at -82 dBm		50/50		dB

## Mesh Networking Module CTL3212

Parameter	Condition / Note	Min	Typ.	Max	Unit
Supply voltage		1.8		3.8	V
Current consumption, RX mode	250 kbps, DSSS-OQPSK, 2.4 GHz		12.2		mA
Current consumption, TX mode				200	mA
Deep sleep current			2.8		uA
Flash memory	FLASH memory in EFR32		512		KB
RAM	RAM in EFR32		64		KB
MCU clock frequency			38.4		MHz
MCU Low Speed Clock	External crystal or Internal clock		32.768		KHz

### 7. Typical application block

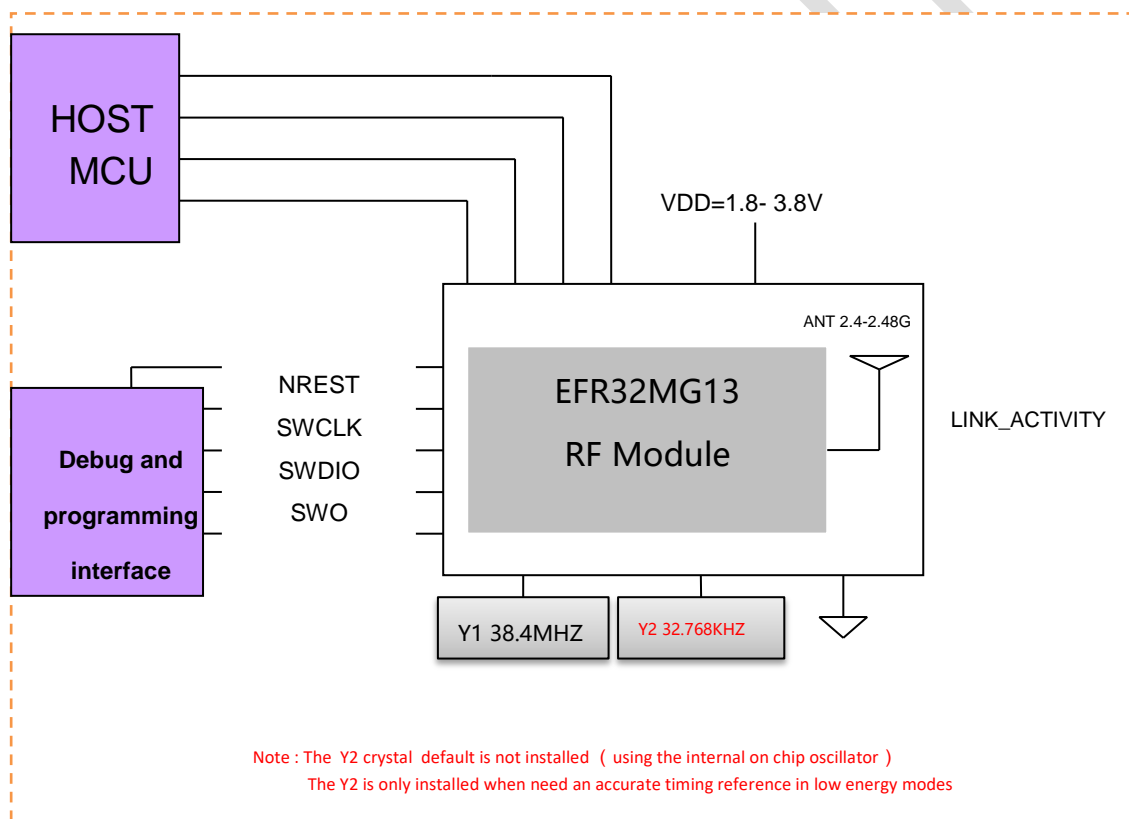
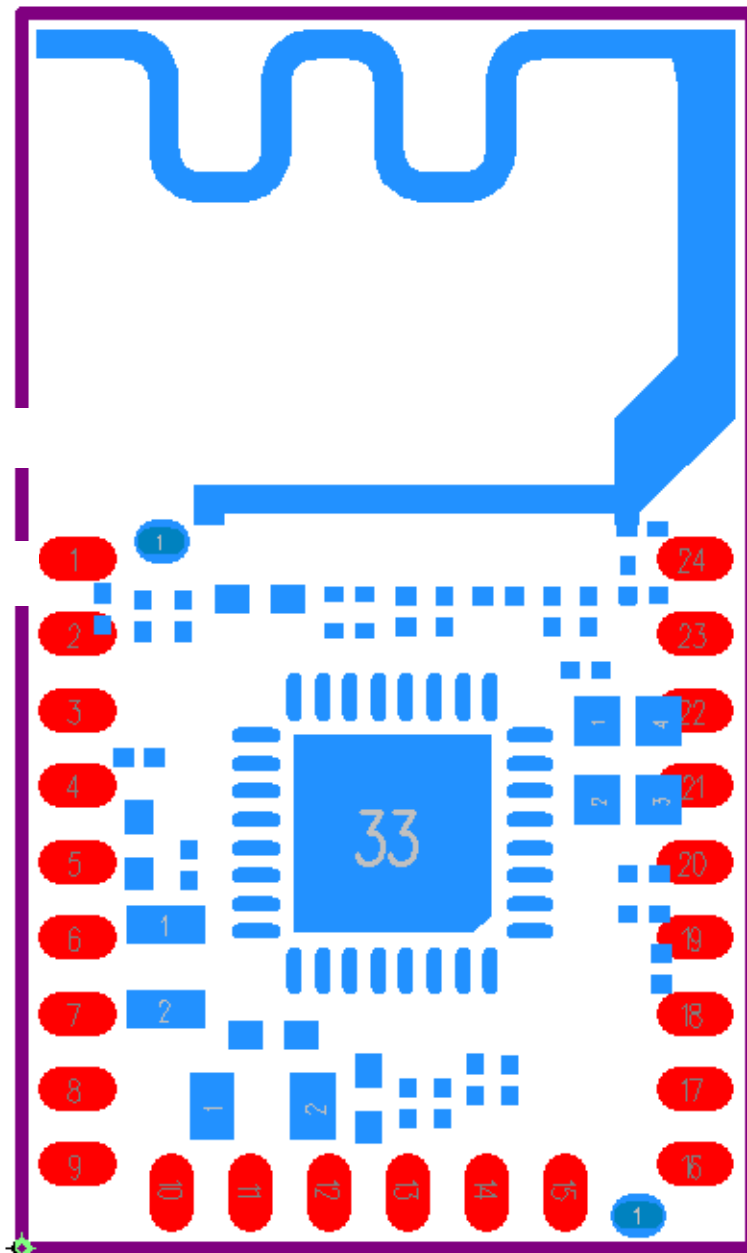

**Figure 1: Example of application circuit**

## 8. Pin Assignment

Figure 2: CTL321X pin assignment

TOP VIEW



## 9. Pin Description

Module Pin#	EFR32 Pin#	Pin Alternate Functionality / Description				
		Analog	Timers	Communication	Radio	Other

**Mesh Networking Module CTL3212**

Module Pin#	EFR32 Pin#	Pin Alternate Functionality / Description				
		Analog	Timers	Communication	Radio	Other
1	GND					
2	PB11	BUSCY BUSDX OPA2_P	TIM0_CC0 #6 TIM0_CC1 #5 TIM0_CC2 #4 TIM0_CDTI0 #3 TIM0_CDTI1 #2 TIM0_CDTI2 #1 TIM1_CC0 #6 TIM1_CC1 #5 TIM1_CC2 #4 TIM1_CC3 #3 WTIM0_CC0 #15 WTIM0_CC1 #13 WTIM0_CC2 #11 WTIM0_CDTI0 #7 WTIM0_CDTI1 #5 WTIM0_CDTI2 #3 LETIM0_OUT0 #6 LETIM0_OUT1 #5 PCNT0_S0IN #6 PCNT0_S1IN #5	US0_TX #6 US0_RX #5 US0_CLK #4 US0_CS #3 US0_CTS #2 US0_RTS #1 US1_TX #6 US1_RX #5 US1_CLK #4 US1_CS #3 US1_CTS #2 US1_RTS #1 LEU0_TX #6 LEU0_RX #5 I2C0_SDA #6 I2C0_SCL #5	FRC_DCLK #6 FRC_DOUT #5 FRC_DFRAME #4 MODEM_DCLK #6 MODEM_DIN #5 MODEM_DOUT #4 MODEM_ANT0 #3 MODEM_ANT1 #2	PRS_CH6 #6 PRS_CH7 #5 PRS_CH8 #4 PRS_CH9 #3 ACMP0_O #6 ACMP1_O #6
3	PB12	BUSDY BUSCX OPA2_OUT	TIM0_CC0 #7 TIM0_CC1 #6 TIM0_CC2 #5 TIM0_CDTI0 #4 TIM0_CDTI1 #3 TIM0_CDTI2 #2 TIM1_CC0 #7 TIM1_CC1 #6 TIM1_CC2 #5 TIM1_CC3 #4 WTIM0_CC0 #16 WTIM0_CC1 #14 WTIM0_CC2 #12 WTIM0_CDTI0 #8 WTIM0_CDTI1 #6 WTIM0_CDTI2 #4 LETIM0_OUT0 #7 LETIM0_OUT1 #6 PCNT0_S0IN #7 PCNT0_S1IN #6#27	US0_TX #7 US0_RX #6 US0_CLK #5 US0_CS #4 US0_CTS #3 US0_RTS #2 US1_TX #7 US1_RX #6 US1_CLK #5 US1_CS #4 US1_CTS #3 US1_RTS #2 LEU0_TX #7 LEU0_RX #6 I2C0_SDA #7 I2C0_SCL #6	FRC_DCLK #7 FRC_DOUT #6 FRC_DFRAME #5 MODEM_DCLK #7 MODEM_DIN #6 MODEM_DOUT #5 MODEM_ANT0 #4 MODEM_ANT1 #3	PRS_CH6 #7 PRS_CH7 #6 PRS_CH8 #5 PRS_CH9 #4 ACMP0_O #7 ACMP1_O #7
4	PB13	BUSCY BUSDX OPA2_N	TIM0_CC0 #8 TIM0_CC1 #7 TIM0_CC2 #6 TIM0_CDTI0 #5 TIM0_CDTI1 #4 TIM0_CDTI2 #3 TIM1_CC0 #8 TIM1_CC1 #7 TIM1_CC2 #6 TIM1_CC3 #5 WTIM0_CC0 #17 WTIM0_CC1 #15 WTIM0_CC2 #13 WTIM0_CDTI0 #9 WTIM0_CDTI1 #7 WTIM0_CDTI2 #5 LETIM0_OUT0 #8 LETIM0_OUT1 #7 PCNT0_S0IN #8 PCNT0_S1IN #7	US0_TX #8 US0_RX #7 US0_CLK #6 US0_CS #5 US0_CTS #4 US0_RTS #3 US1_TX #8 US1_RX #7 US1_CLK #6 US1_CS #5 US1_CTS #4 US1_RTS #3 LEU0_TX #8 LEU0_RX #7 I2C0_SDA #8 I2C0_SCL #7	FRC_DCLK #8 FRC_DOUT #7 FRC_DFRAME #6 MODEM_DCLK #8 MODEM_DIN #7 MODEM_DOUT #6 MODEM_ANT0 #5 MODEM_ANT1 #4	CMU_CLKI0 #0 PRS_CH6 #8 PRS_CH7 #7 PRS_CH8 #6 PRS_CH9 #5 ACMP0_O #8 ACMP1_O #8 DBG_SWO #1 GPIO_EM4WU 9
5	PB14	BUSDY BUSCX	TIM0_CC0 #9 TIM0_CC1 #8	US0_TX #9 US0_RX #8	FRC_DCLK #9 FRC_DOUT #8	CMU_CLK1 #1 PRS_CH6 #9



**Mesh Networking Module CTL3212**

Module Pin#	EFR32 Pin#	Pin Alternate Functionality / Description				
		Analog	Timers	Communication	Radio	Other
		LFXTAL_N	TIM0_CC2 #7 TIM0_CDTI0 #6 TIM0_CDTI1 #5 TIM0_CDTI2 #4 TIM1_CC0 #9 TIM1_CC1 #8 TIM1_CC2 #7 TIM1_CC3 #6 WTIM0_CC0 #18 WTIM0_CC1 #16 WTIM0_CC2 #14 WTIM0_CDTI0 #10 WTIM0_CDTI1 #8 WTIM0_CDTI2 #6 LETIM0_OUT0 #9 LETIM0_OUT1 #8 PCNT0_S0IN #9 PCNT0_S1IN #8	US0_CLK #7 US0_CS #6 US0_CTS #5 US0_RTS #4 US1_TX #9 US1_RX #8 US1_CLK #7 US1_CS #6 US1_CTS #5 US1_RTS #4 LEU0_TX #9 LEU0_RX #8 I2C0_SDA #9 I2C0_SCL #8	FRC_DFRAME #7 MODEM_DCLK #9 MODEM_DIN #8 MODEM_DOUT #7 MODEM_ANT0 #6 MODEM_ANT1 #5	PRS_CH7 #8 PRS_CH8 #7 PRS_CH9 #6 ACMP0_O #9 ACMP1_O #9
6	PB15	BUSCY BUSDX LFXTAL_P	TIM0_CC0 #10 TIM0_CC1 #9 TIM0_CC2 #8 TIM0_CDTI0 #7 TIM0_CDTI1 #6 TIM0_CDTI2 #5 TIM1_CC0 #10 TIM1_CC1 #9 TIM1_CC2 #8 TIM1_CC3 #7 WTIM0_CC0 #19 WTIM0_CC1 #17 WTIM0_CC2 #15 WTIM0_CDTI0 #11 WTIM0_CDTI1 #9 WTIM0_CDTI2 #7 LETIM0_OUT0 #10 LETIM0_OUT1 #9 PCNT0_S0IN #10 PCNT0_S1IN #9	US0_TX #10 US0_RX #9 US0_CLK #8 US0_CS #7 US0_CTS #6 US0_RTS #5 US1_TX #10 US1_RX #9 US1_CLK #8 US1_CS #7 US1_CTS #6 US1_RTS #5 LEU0_TX #10 LEU0_RX #9 I2C0_SDA #10 I2C0_SCL #9	FRC_DCLK #10 FRC_DOUT #9 FRC_DFRAME #8 MODEM_DCLK #10 MODEM_DIN #9 MODEM_DOUT #8 MODEM_ANT0 #7 MODEM_ANT1 #6	CMU_CLK0 #1 PRS_CH6 #10 PRS_CH7 #9 PRS_CH8 #8 PRS_CH9 #7 ACMP0_O #10 ACMP1_O #10
7	PF1	BUSAY BUSBX	TIM0_CC0 #25 TIM0_CC1 #24 TIM0_CC2 #23 TIM0_CDTI0 #22 TIM0_CDTI1 #21 TIM0_CDTI2 #20 TIM1_CC0 #25 TIM1_CC1 #24 TIM1_CC2 #23 TIM1_CC3 #22 WTIM0_CDTI1 #31 WTIM0_CDTI2 #29 LETIM0_OUT0 #25 LETIM0_OUT1 #24 PCNT0_S0IN #25 PCNT0_S1IN #24	US0_TX #25 US0_RX #24 US0_CLK #23 US0_CS #22 US0_CTS #21 US0_RTS #20 US1_TX #25 US1_RX #24 US1_CLK #23 US1_CS #22 US1_CTS #21 US1_RTS #20 US2_TX #15 US2_RX #14 US2_CLK #13 US2_CS #12 US2_CTS #11 US2_RTS #10 LEU0_TX #25 LEU0_RX #24 I2C0_SDA #25 I2C0_SCL #24	FRC_DCLK #25 FRC_DOUT #24 FRC_DFRAME #23 MODEM_DCLK #25 MODEM_DIN #24 MODEM_DOUT #23 MODEM_ANT0 #22 MODEM_ANT1 #21	PRS_CH0 #1 PRS_CH1 #0 PRS_CH2 #7 PRS_CH3 #6 ACMP0_O #25 ACMP1_O #25 DBG_SWDIOT MS BOOT_RX
8	PF0	BUSBY BUSAX	TIM0_CC0 #24 TIM0_CC1 #23 TIM0_CC2 #22 TIM0_CDTI0 #21	US0_TX #24 US0_RX #23 US0_CLK #22 US0_CS #21	FRC_DCLK #24 FRC_DOUT #23 FRC_DFRAME #22 MODEM_DCLK #24	PRS_CH0 #0 PRS_CH1 #7 PRS_CH2 #6 PRS_CH3 #5

**Mesh Networking Module CTL3212**

Module Pin#	EFR32 Pin#	Pin Alternate Functionality / Description				
		Analog	Timers	Communication	Radio	Other
			TIM0_CDT1 #20 TIM0_CDT2 #19 TIM1_CC0 #24 TIM1_CC1 #23 TIM1_CC2 #22 TIM1_CC3 #21 WTIM0_CDT1 #30 WTIM0_CDT2 #28 LETIM0_OUT0 #24 LETIM0_OUT1 #23 PCNT0_S0IN #24 PCNT0_S1IN #23	US0_CTS #20 US0_RTS #19 US1_TX #24 US1_RX #23 US1_CLK #22 US1_CS #21 US1_CTS #20 US1_RTS #19 US2_TX #14 US2_RX #13 US2_CLK #12 US2_CS #11 US2_CTS #10 US2_RTS #9 LEU0_TX #24 LEU0_RX #23 I2C0_SDA #24 I2C0_SCL #23	MODEM_DIN #23 MODEM_DOUT #22 MODEM_ANT0 #21 MODEM_ANT1 #20	ACMP0_O #24 ACMP1_O #24 DBG_SWCLKT CK BOOT_TX
9	GND					
10	PD15	VDAC0_O UT0ALT / OPA0_OU TALT #2 BUSCY BUSDX OPA1_N	TIM0_CC0 #23 TIM0_CC1 #22 TIM0_CC2 #21 TIM0_CDT0 #20 TIM0_CDT1 #19 TIM0_CDT2 #18 TIM1_CC0 #23 TIM1_CC1 #22 TIM1_CC2 #21 TIM1_CC3 #20 WTIM0_CDT0 #31 WTIM0_CDT1 #29 WTIM0_CDT2 #27 LETIM0_OUT0 #23 LETIM0_OUT1 #22 PCNT0_S0IN #23 PCNT0_S1IN #22	US0_TX #23 US0_RX #22 US0_CLK #21 US0_CS #20 US0_CTS #19 US0_RTS #18 US1_TX #23 US1_RX #22 US1_CLK #21 US1_CS #20 US1_CTS #19 US1_RTS #18 LEU0_TX #23 LEU0_RX #22 I2C0_SDA #23 I2C0_SCL #22	FRC_DCLK #23 FRC_DOUT #22 FRC_DFRAME #21 MODEM_DCLK #23 MODEM_DIN #22 MODEM_DOUT #21 MODEM_ANT0 #20 MODEM_ANT1 #19	CMU_CLK1 #5 PRS_CH3 #14 PRS_CH4 #6 PRS_CH5 #5 PRS_CH6 #17 ACMP0_O #23 ACMP1_O #23 LES_CH7 DBG_SWO #2
11	PA1	BUSCY BUSDX ADC0_EXT P VDAC0_EX T	TIM0_CC0 #1 TIM0_CC1 #0 TIM0_CC2 #31 TIM0_CDT0 #30 TIM0_CDT1 #29 TIM0_CDT2 #28 TIM1_CC0 #1 TIM1_CC1 #0 TIM1_CC2 #31 TIM1_CC3 #30 WTIM0_CC0 #1 LETIM0_OUT0 #1 LETIM0_OUT1 #0 PCNT0_S0IN #1 PCNT0_S1IN #0	US0_TX #1 US0_RX #0 US0_CLK #31 US0_CS #30 US0_CTS #29 US0_RTS #28 US1_TX #1 US1_RX #0 US1_CLK #31 US1_CS #30 US1_CTS #29 US1_RTS #28 LEU0_TX #1 LEU0_RX #0 I2C0_SDA #1 I2C0_SCL #0	FRC_DCLK #1 FRC_DOUT #0 FRC_DFRAME #31 MODEM_DCLK #1 MODEM_DIN #0 MODEM_DOUT #31 MODEM_ANT0 #30 MODEM_ANT1 #29	CMU_CLK0 #0 PRS_CH6 #1 PRS_CH7 #0 PRS_CH8 #10 PRS_CH9 #9 ACMP0_O #1 ACMP1_O #1 LES_CH9
12	PA0	BUSDY BUSCX ADC0_EXT N	TIM0_CC0 #0 TIM0_CC1 #31 TIM0_CC2 #30 TIM0_CDT0 #29 TIM0_CDT1 #28 TIM0_CDT2 #27 TIM1_CC0 #0 TIM1_CC1 #31 TIM1_CC2 #30 TIM1_CC3 #29 WTIM0_CC0 #0 LETIM0_OUT0 #0	US0_TX #0 US0_RX #31 US0_CLK #30 US0_CS #29 US0_CTS #28 US0_RTS #27 US1_TX #0 US1_RX #31 US1_CLK #30 US1_CS #29 US1_CTS #28 US1_RTS #27	FRC_DCLK #0 FRC_DOUT #31 FRC_DFRAME #30 MODEM_DCLK #0 MODEM_DIN #31 MODEM_DOUT #30 MODEM_ANT0 #29 MODEM_ANT1 #28	CMU_CLK1 #0 PRS_CH6 #0 PRS_CH7 #10 PRS_CH8 #9 PRS_CH9 #8 ACMP0_O #0 ACMP1_O #0 LES_CH8

**Mesh Networking Module CTL3212**

Module Pin#	EFR32 Pin#	Pin Alternate Functionality / Description				
		Analog	Timers	Communication	Radio	Other
			LETIMO_OUT1 #31 PCNT0_S0IN #0 PCNT0_S1IN #31	LEU0_TX #0 LEU0_RX #31 I2C0_SDA #0 I2C0_SCL #31		
13	PF2	BUSBY BUSAX	TIM0_CC0 #26 TIM0_CC1 #25 TIM0_CC2 #24 TIM0_CDTI0 #23 TIM0_CDTI1 #22 TIM0_CDTI2 #21 TIM1_CC0 #26 TIM1_CC1 #25 TIM1_CC2 #24 TIM1_CC3 #23 WTIM0_CDTI2 #30 LETIMO_OUT0 #26 LETIMO_OUT1 #25 PCNT0_S0IN #26 PCNT0_S1IN #25	US0_TX #26 US0_RX #25 US0_CLK #24 US0_CS #23 US0_CTS #22 US0_RTS #21 US1_TX #26 US1_RX #25 US1_CLK #24 US1_CS #23 US1_CTS #22 US1_RTS #21 LEU0_TX #26 LEU0_RX #25 I2C0_SDA #26 I2C0_SCL #25	FRC_DCLK #26 FRC_DOUT #25 FRC_DFRAME #24 MODEM_DCLK #26 MODEM_DIN #25 MODEM_DOUT #24 MODEM_ANT0 #23 MODEM_ANT1 #22	CMU_CLK0 #6 PRS_CH0 #2 PRS_CH1 #1 PRS_CH2 #0 PRS_CH3 #7 ACMP0_O #26 ACMP1_O #26 DBG_TDO DBG_SWO #0 GPIO_EM4WU 0
14	PC10	BUSBY BUSAX	TIM0_CC0 #15 TIM0_CC1 #14 TIM0_CC2 #13 TIM0_CDTI0 #12 TIM0_CDTI1 #11 TIM0_CDTI2 #10 TIM1_CC0 #15 TIM1_CC1 #14 TIM1_CC2 #13 TIM1_CC3 #12 WTIM0_CC0 #30 WTIM0_CC1 #28 WTIM0_CC2 #26 WTIM0_CDTI0 #22 WTIM0_CDTI1 #20 WTIM0_CDTI2 #18 LETIMO_OUT0 #15 LETIMO_OUT1 #14 PCNT0_S0IN #15 PCNT0_S1IN #14	US0_TX #15 US0_RX #14 US0_CLK #13 US0_CS #12 US0_CTS #11 US0_RTS #10 US1_TX #15 US1_RX #14 US1_CLK #13 US1_CS #12 US1_CTS #11 US1_RTS #10 LEU0_TX #15 LEU0_RX #14 I2C0_SDA #15 I2C0_SCL #14 I2C1_SDA #19 I2C1_SCL #18	FRC_DCLK #15 FRC_DOUT #14 FRC_DFRAME #13 MODEM_DCLK #15 MODEM_DIN #14 MODEM_DOUT #13 MODEM_ANT0 #12 MODEM_ANT1 #11	CMU_CLK1 #3 PRS_CH0 #12 PRS_CH9 #15 PRS_CH10 #4 PRS_CH11 #3 ACMP0_O #15 ACMP1_O #15 ETM_TD3 GPIO_EM4WU 12
15	PC11	BUSAY BUSBX	TIM0_CC0 #16 TIM0_CC1 #15 TIM0_CC2 #14 TIM0_CDTI0 #13 TIM0_CDTI1 #12 TIM0_CDTI2 #11 TIM1_CC0 #16 TIM1_CC1 #15 TIM1_CC2 #14 TIM1_CC3 #13 WTIM0_CC0 #31 WTIM0_CC1 #29 WTIM0_CC2 #27 WTIM0_CDTI0 #23 WTIM0_CDTI1 #21 WTIM0_CDTI2 #19 LETIMO_OUT0 #16 LETIMO_OUT1 #15 PCNT0_S0IN #16 PCNT0_S1IN #15	US0_TX #16 US0_RX #15 US0_CLK #14 US0_CS #13 US0_CTS #12 US0_RTS #11 US1_TX #16 US1_RX #15 US1_CLK #14 US1_CS #13 US1_CTS #12 US1_RTS #11 LEU0_TX #16 LEU0_RX #15 I2C0_SDA #16 I2C0_SCL #15 I2C1_SDA #20 I2C1_SCL #1	FRC_DCLK #16 FRC_DOUT #15 FRC_DFRAME #14 MODEM_DCLK #16 MODEM_DIN #15 MODEM_DOUT #14 MODEM_ANT0 #13 MODEM_ANT1 #12	CMU_CLK0 #3 PRS_CH0 #13 PRS_CH9 #16 PRS_CH10 #5 PRS_CH11 #4 ACMP0_O #16 ACMP1_O #16 DBG_SWO #3
16	GND					
17	PF3	BUSAY BUSBX	TIM0_CC0 #27 TIM0_CC1 #26 TIM0_CC2 #25	US0_TX #27 US0_RX #26 US0_CLK #25	FRC_DCLK #27 FRC_DOUT #26 FRC_DFRAME #25	CMU_CLK1 #6 PRS_CH0 #3 PRS_CH1 #2

**Mesh Networking Module CTL3212**

Module Pin#	EFR32 Pin#	Pin Alternate Functionality / Description				
		Analog	Timers	Communication	Radio	Other
			TIM0_CDTI0 #24 TIM0_CDTI1 #23 TIM0_CDTI2 #22 TIM1_CC0 #27 TIM1_CC1 #26 TIM1_CC2 #25 TIM1_CC3 #24 WTIM0_CDTI2 #31 LETIM0_OUT0 #27 LETIM0_OUT1 #26 PCNT0_S0IN #27 PCNT0_S1IN #26	US0_CS #24 US0_CTS #23 US0_RTS #22 US1_TX #27 US1_RX #26 US1_CLK #25 US1_CS #24 US1_CTS #23 US1_RTS #22 US2_TX #16 US2_RX #15 US2_CLK #14 US2_CS #13 US2_CTS #12 US2_RTS #11 LEU0_TX #27 LEU0_RX #26 I2C0_SDA #27 I2C0_SCL #26	MODEM_DCLK #27 MODEM_DIN #26 MODEM_DOUT #25 MODEM_ANT0 #24 MODEM_ANT1 #23	PRS_CH2 #1 PRS_CH3 #0 ACMP0_O #27 ACMP1_O #27 DBG_TDI
18	PD14	BUSCY BUSDX VDAC0_O UT0 / OPA0_OUT	TIM0_CC0 #3 TIM0_CC1 #2 TIM0_CC2 #1 TIM0_CDTI0 #0 TIM0_CDTI1 #31 TIM0_CDTI2 #30 TIM1_CC0 #3 TIM1_CC1 #2 TIM1_CC2 #1 TIM1_CC3 #0 WTIM0_CC0 #3 WTIM0_CC1 #1 LETIM0_OUT0 #3 LETIM0_OUT1 #2 PCNT0_S0IN #3 PCNT0_S1IN #2	US0_TX #3 US0_RX #2 US0_CLK #1 US0_CS #0 US0_CTS #31 US0_RTS #30 US1_TX #3 US1_RX #2 US1_CLK #1 US1_CS #0 US1_CTS #31 US1_RTS #30 LEU0_TX #3 LEU0_RX #2 I2C0_SDA #3 I2C0_SCL #2	FRC_DCLK #3 FRC_DOUT #2 FRC_DFRAME #1 MODEM_DCLK #3 MODEM_DIN #2 MODEM_DOUT #1 MODEM_ANT0 #0 MODEM_ANT1 #31	PRS_CH6 #3 PRS_CH7 #2 PRS_CH8 #1 PRS_CH9 #0 ACMP0_O #3 ACMP1_O #3 LES_CH11 GPIO_EM4WU 8
19	PD13	VDAC0_O UT0ALT / OPA0_OUT TALT #1 BUSCY BUSDX OPA1_P	TIM0_CC0 #21 TIM0_CC1 #20 TIM0_CC2 #19 TIM0_CDTI0 #18 TIM0_CDTI1 #17 TIM0_CDTI2 #16 TIM1_CC0 #21 TIM1_CC1 #20 TIM1_CC2 #19 TIM1_CC3 #18 WTIM0_CDTI0 #29 WTIM0_CDTI1 #27 WTIM0_CDTI2 #25 LETIM0_OUT0 #21 LETIM0_OUT1 #20 PCNT0_S0IN #21 PCNT0_S1IN #20	US0_TX #21 US0_RX #20 US0_CLK #19 US0_CS #18 US0_CTS #17 US0_RTS #16 US1_TX #21 US1_RX #20 US1_CLK #19 US1_CS #18 US1_CTS #17 US1_RTS #16 LEU0_TX #21 LEU0_RX #20 I2C0_SDA #21 I2C0_SCL #20	FRC_DCLK #21 FRC_DOUT #20 FRC_DFRAME #19 MODEM_DCLK #21 MODEM_DIN #20 MODEM_DOUT #19 MODEM_ANT0 #18 MODEM_ANT1 #17	PRS_CH3 #12 PRS_CH4 #4 PRS_CH5 #3 PRS_CH6 #15 ACMP0_O #21 ACMP1_O #21 LES_CH5
20	VDD					Chip power input
21	RST					Chip reset
22	GND					
23	ANT_E					an optional external RF input
24	GND					

## 10. Block Diagram

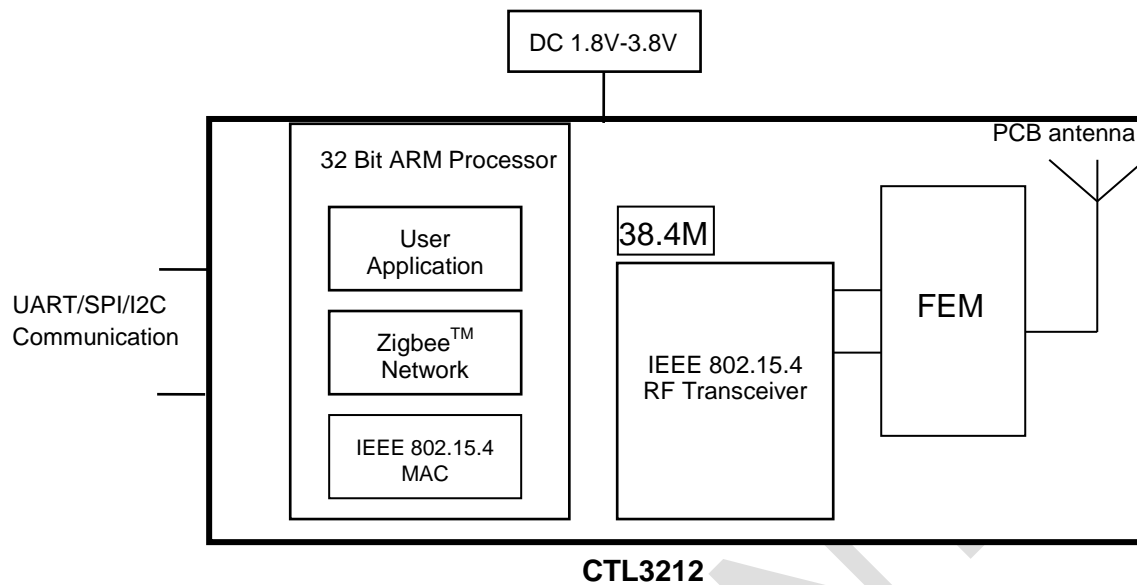

**Figure 3: Block Diagram**

## 11. RF Frequency Detail

The following table shows the RF channels as defined by the IEEE 802.15.4 standard.

RF channel	Frequency
11	2405MHz
12	2410MHz
13	2415MHz
14	2420MHz
15	2425MHz
16	2430MHz
17	2435MHz
18	2440MHz
19	2445MHz
20	2450MHz
21	2455MHz
22	2460MHz
23	2465MHz
24	2470MHz
25	2475MHz
26	2480MHz

The use of RF frequencies and maximum allowed RF power should according to different national regulations. The CTL321X are complying with the applicable regulations for the world wide 2.4GHz ISM band.

## Mesh Networking Module CTL3212

The following table is the setting for the CTL3212 to US and Europe market:

FCC/IC		
Channel	CH11~25	CH26
Freq(MHz)	2405~2475	2480
Power setting	19dBm	19dBm ( base on FCC test result to adjust)
CE		
Channel	CH11~CH26	
Freq(MHz)	2405~2480	
Power setting	10dBm	

## 12. PCB Layout Recommendations

Please reference Mechanical Dimensions shown in next section for PCB layout.

The area underneath the module should be covered with solder mask in order to prevent short circuit on the test pads on the back side of the module. A solid ground plane under the module is preferred.

As the module integrated with onboard PCB trace antenna, the mounting position of the module will have great impact on the RF performance. There should not be any trace, ground plane or metal part underneath or nearby the area of the onboard PCB trace antenna. The figure below shows an example how the module positioned on the mother PCB.

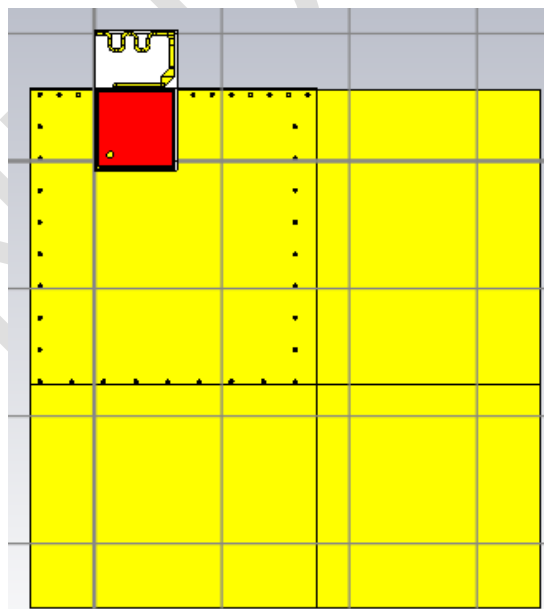
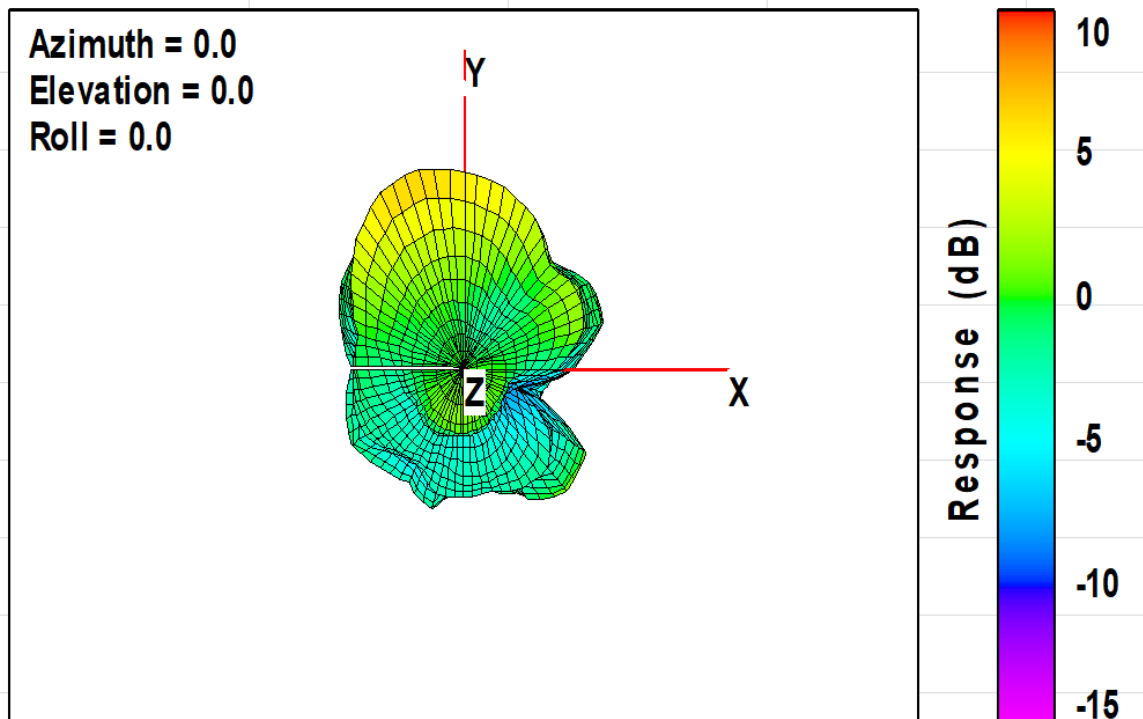
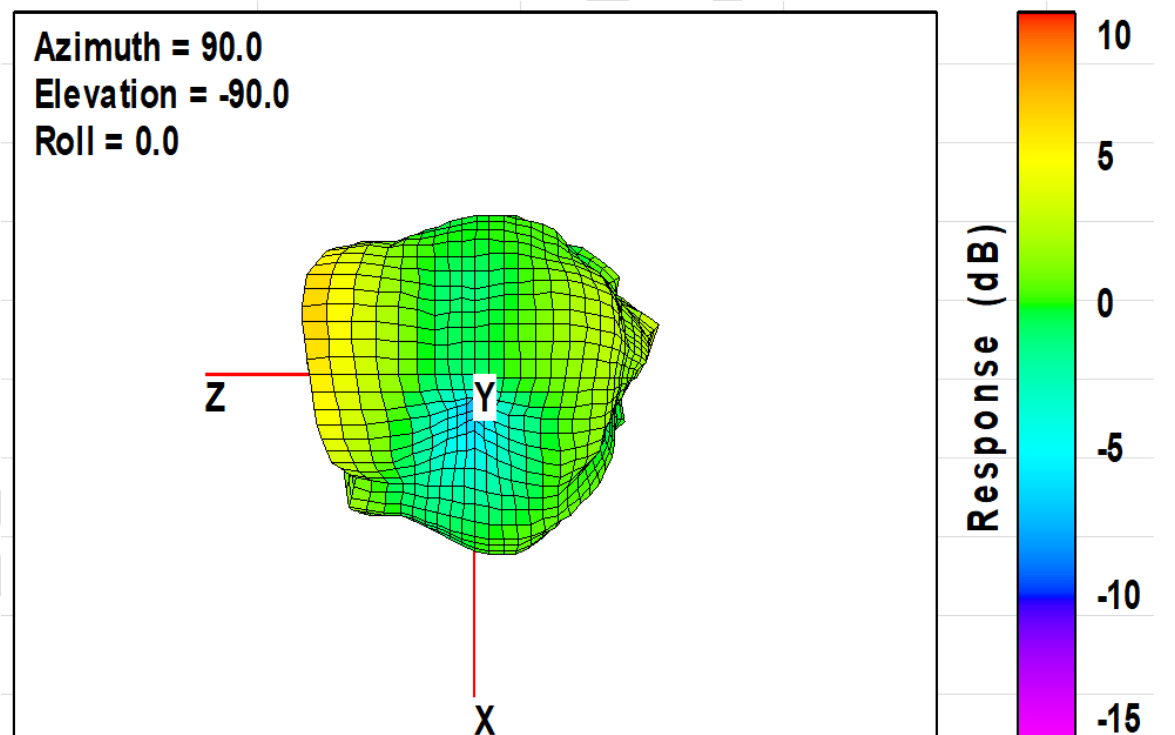
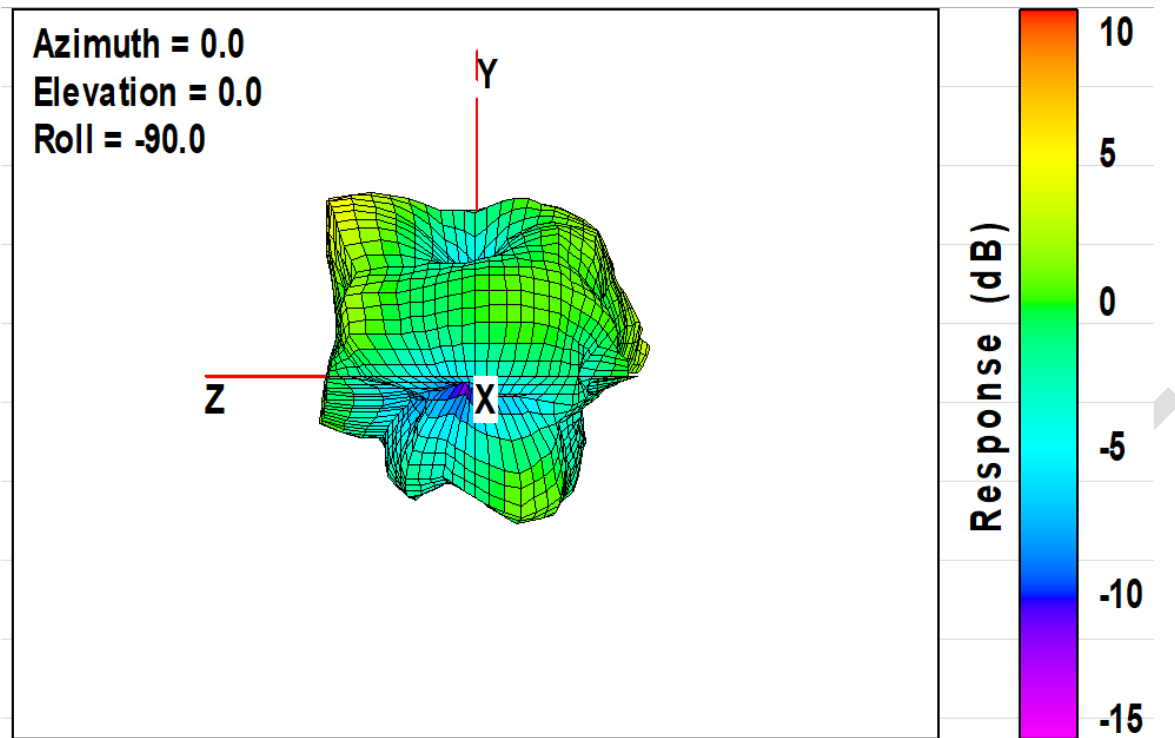

Figure 4: A recommended placement of the module on a main PCB

**13. Antenna test**
**14.1 Passive OTA test data**

Frequency(MHZ)	Efficiency (dB)	Efficiency (%)	Gain(dBi)
2405	-0.75	84.21%	7.28
2440	-0.59	87.26%	7.22
2480	-0.53	88.44%	6.81

**14.2 Passive OTA test Pattern**





**14.3 Antenna S11 Test**

**14.4 Passive OTA test Unit photo**

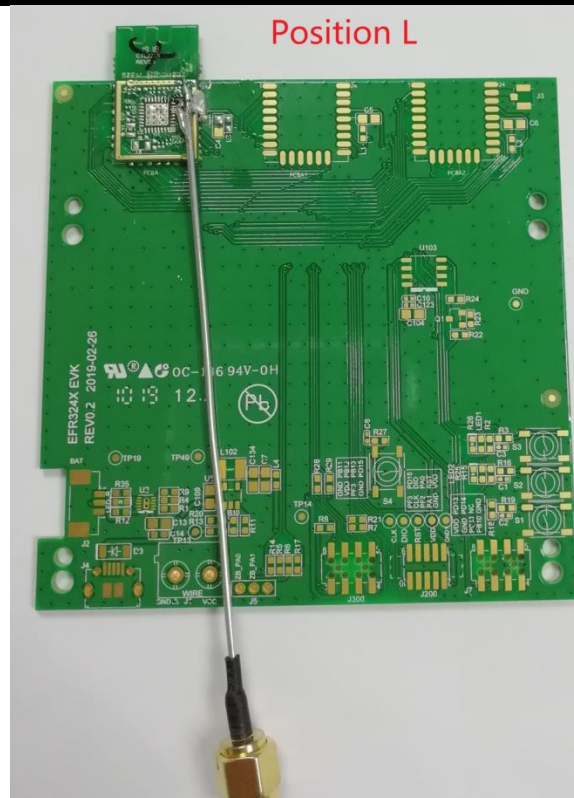
#### 14. Mechanical Dimensions

Figure 5: Mechanical Dimensions of CTL321X



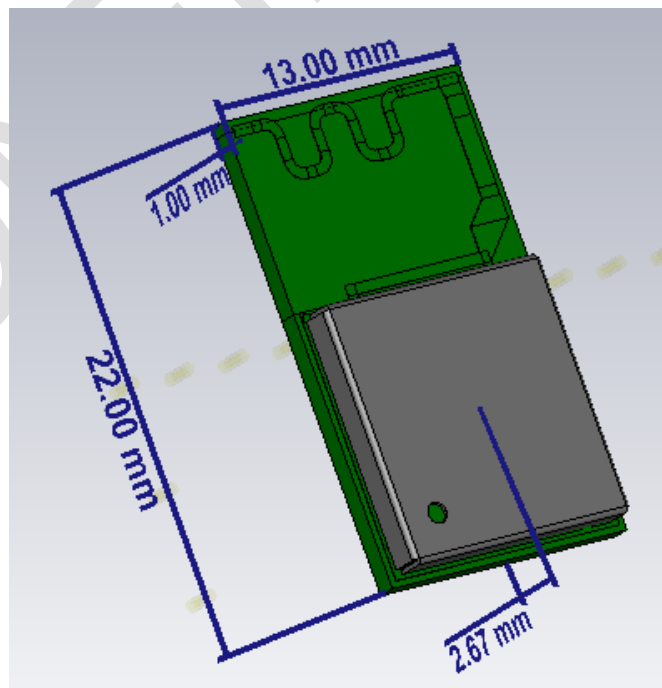

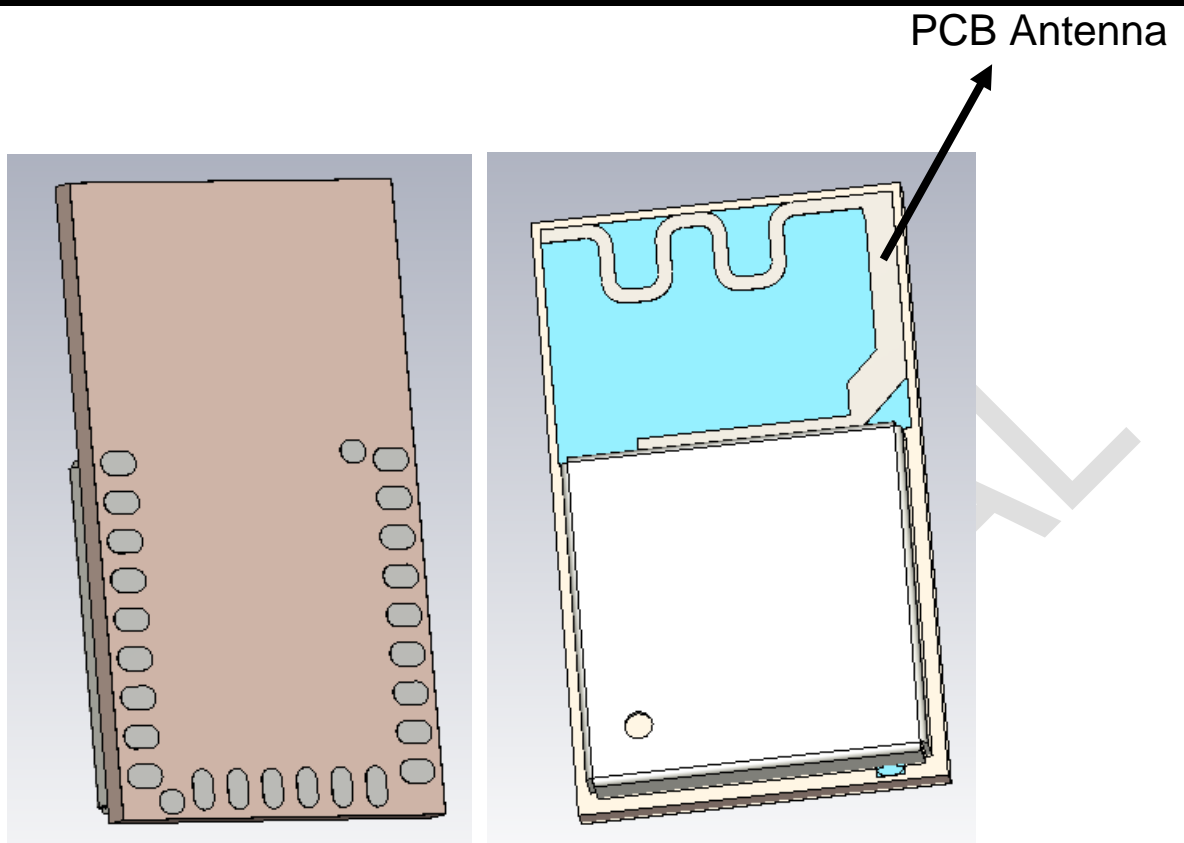
For further details on the SoC transceiver (Ember EFR32MG13P)

## **15. Regulatory Statements**

### **16.1 FCC Statements**

This device complies with part 15 of the FCC Rules. Operation is subject to the following two conditions:

- 1) This device may not cause harmful interference, and
- 2) This device must accept any interference received, including interference that may cause undesired operation.

Cet appareil est conforme à la section 15 des réglementations de la FCC. Le fonctionnement de l'appareil est sujet aux deux conditions suivantes :

- 1) cet appareil ne doit pas provoquer d'interférences néfastes, et
- 2) cet appareil doit tolérer les interférences reçues, y compris celles qui risquent de provoquer un fonctionnement indésirable.

Note: This product has been tested and found to comply with the limits for a Class B digital device, pursuant to part 15 of the FCC Rules. These limits are designed to provide reasonable protection against harmful interference in a residential installation. This product generates, uses, and can radiate radio frequency energy and, if not installed and used in accordance with the instructions, may cause harmful interference to radio communications. However, there is no guarantee that interference will not occur in a particular installation. If this product does cause harmful interference to radio or television reception, which can be determined by turning the equipment off and on, the user is encouraged to try to correct the interference by one or more of the following measures:

- Reorient or relocate the receiving antenna.
- Increase the separation between the equipment and receiver.
- Connect the equipment into an outlet on a circuit different from that to which the receiver is connected.
- Consult the dealer or an experienced radio/TV technician for help.

**Warning:** Changes or modifications to this unit not expressly approved by the party responsible for compliance could void the user's authority to operate the equipment.

### **FCC Radiation Exposure Statement**

This equipment complies with FCC radiation exposure limits set forth for an uncontrolled environment. End users must follow the specific operating instructions for satisfying RF exposure compliance.

**Note 1:** This module certified complies with RF exposure requirements under mobile or fixed condition; this module is to be installed only in mobile or fixed applications.

A mobile device is defined as a transmitting device designed to be used in other than fixed locations and to generally be used in such a way that a separation distance of at least 20 centimeters is normally maintained between the transmitter's radiating structure(s) and the body of the user or nearby persons. Transmitting devices designed to be used by consumers or workers that can be easily re-located, such as wireless devices associated with a personal computer, are considered to be mobile devices if they meet the 20 centimeter separation requirement.

## Mesh Networking Module CTL3212

---

A fixed device is defined as a device is physically secured at one location and is not able to be easily moved to another location.

**Note 2:** Host product manufacturers must provide in their user manual the required RF exposure information for mobile & fixed usage of this module. Host product manufacturers must use the following RF exposure statement in their user manual “This equipment complies with FCC radiation exposure limits set forth for an uncontrolled environment. This equipment should be installed and operated with a minimum distance of 20 cm between the radiator and all persons. This transmitter must not be co-location or operating in conjunction with any other antenna or transmitter.”

**Note 3:** Any modifications made to the module will void the Grant of Certification, this module is limited to OEM installation only and must not be sold to end-users, end-user shall have no manual instructions to remove or install the device, only software or operating procedure shall be placed in the end-user operating manual of final products.

**Note 4:** Additional testing and certification may be necessary when multiple modules are used.

**Note 5:** The module may be operated only with the integral chip antenna with which it is authorized.

**Note 6:** To ensure compliance with all non-transmitter functions the host manufacturer is responsible for ensuring compliance with the module(s) installed and fully operational. For example, if a host was previously authorized as an unintentional radiator under the Supplier’s Declaration of Conformity procedure without a transmitter certified module and a module is added, the host manufacturer is responsible for ensuring that the after the module is installed and operational the host continues to be compliant with the part 15B unintentional radiator requirements. Since this may depend on the details of how the module is integrated with the host, the manufacturer shall provide guidance to the host manufacturer for compliance with the part 15B requirements.

**Note 7:** The FCC ID label on the final system must be labeled with “Contains FCC ID: 2AAUQ-CTL3212” or

“Contains transmitter module FCC ID: 2AAUQ-CTL3212”.

**Note 8:** The FCC rule/s for this module are CFR 47 Part 15 Subpart C.

**Note 9:** This modular transmitter is only FCC authorized for the specific rule parts listed on its grant. The host product manufacturer is responsible to any other FCC rules that apply to the host not covered by the modular transmitter grant of certification. The final host product will require Part 15 Subpart B compliance when the modular transmitter is installed.

### 16.2 ISED Statements`

This device complies with Innovation, Science and Economic Development Canada’s license-exempt RSS standard(s). Operation is subject to the following two conditions:

- 1) this device may not cause interference, and
- 2) this device must accept any interference, including interference that may cause undesired operation of the device.

## Mesh Networking Module CTL3212

---

Le présent appareil est conforme aux CNR d'Innovation, Sciences et Développement Économique Canada applicables aux appareils radioexempts de licence. L'exploitation est autorisée aux deux conditions suivantes :

- 1) l'appareil ne doit pas produire de brouillage, et
- 2) l'utilisateur de l'appareil doit accepter tout brouillage radioélectrique subi, même si le brouillage est susceptible d'en compromettre le fonctionnement.

Under Innovation, Science and Economic Development Canada's regulations, this radio transmitter may only operate using the integral antenna under which it was approved.

Conformément à la réglementation d'Innovation, Sciences et Développement Économique Canada, le présent émetteur radio peut fonctionner avec une antenne fonctionner qu'en utilisant l'antenne intégrée sous laquelle il a été approuvé.

### **ISED RF Exposure Statement**

This equipment complies with ISED radiation exposure limits set forth for an uncontrolled environment. This equipment should be installed and operated with minimum distance 20cm between the radiator & your body. This transmitter must not be co-located or operating in conjunction with any other antenna or transmitter.

Le rayonnement de la classe b respecte ISED fixaient un environnement non contrôlés. Installation et mise en oeuvre de ce matériel devrait avec échangeur distance minimale entre 20 cm ton corps. Lanceurs ou ne peuvent pas coexister cette antenne ou capteurs avec d'autres.

### **ISED Modular Usage Statement**

NOTE 1: When the ISED certification number is not visible when the module is installed inside another device, then the outside of the device into which the module is installed must also display a label referring to the enclosed module. This exterior label can use the wording "Contains transmitter module IC: [1700A-CTL3212](#)" or "Contains IC: [1700A-CTL3212](#)".

NOTE 1: Lorsque le numéro de certification ISED n'est pas visible lorsque le module est installé dans un autre appareil, l'extérieur de l'appareil dans lequel le module est installé doit également afficher une étiquette faisant référence au module inclus. Cette étiquette extérieure peut être libellée Contient le module émetteur IC: [1700A-CTL3212](#) ou Contient IC: [1700A-CTL3212](#).

**Contact information****COMPUTIME CORPORATE HQ**

9/F Tower One, Lippo Centre,  
89 Queensway,  
Hong Kong  
Tel: +852.2260.0300  
Fax: +852.2790.3996  
e-mail: [hq@computime.com](mailto:hq@computime.com)

**COMPUTIME NORTH AMERICA HQ,**

4700 Duke Dr.  
Suite 200  
Mason OH 45040  
USA  
Tel: +1(513).398.2579  
Fax: +1(513).754.8955  
e-mail: [na@computime.com](mailto:na@computime.com)

**Cincinnati Technologies**

4700 Duke Dr.  
Suite 200  
Mason OH 45040  
USA  
Tel: +1(513).754.8935  
Fax: +1(513).754.8955  
e-mail: [ctws@computime.com](mailto:ctws@computime.com)

**About Computime**

Founded in 1974, **Computime** is a global technology, brand and manufacturing company providing innovative automation and control solutions to customers in commercial, industrial and consumer markets.

The Company provides technologies and products that save energy and make people's lives more productive and comfortable.