

Product Warranty Registration

To register your purchased product, please visit:

www.ecogear.com/register



BC

EcoRoam 30

Models: GDI-EXRMS300...320

User Guide



Quick Start

- 1 **Open Cap on the Side Panel, shown below**
- 2 **Turn on the Main Power Switch**
- 3 **Press the Standby Button  to power on your EcoRoam 30**
- 4 **Search your Bluetooth Connection on your Smart Device**
- 5 **Pair & Play**

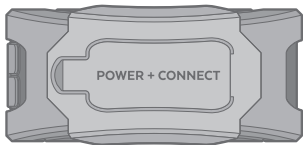

the original owner who purchases the unit from an authorized dealer. Transfers do not qualify for warranty protection. Grace Digital reserves the right to replace any out-of-stock or discontinued product with a comparable product. Discontinued products may not be available for warranty replacement. Any contents are **NOT** covered by the limited manufacturer's warranty. Warranty terms may be revised without notification at the discretion of the manufacturer. Please visit www.ecoxgear.com for additional product & warranty information.

NOTE: Product registration does not constitute proof of purchase for the warranty process. Please keep all receipt and purchase records as your evidence of the date and place of purchase.



EcoRoam 30 by ECOXGEAR, a division of Grace Digital Inc., San Diego, California.
Designed and Engineered in the USA.
Made in China.
Patent Pending.

- 6) **AVOID** prolonged exposure to ultraviolet radiation (UV sunlight) and strong magnetic fields.
- 7) Periodically check the rubber seal for premature wear.
- 8) Periodically clean the rubber with a soft moist cloth and ensure no objects such as dirt, hair, or sand are on the rubber seal ring. Do **NOT** use any oily solvent or chemicals for cleaning.
- 9) Rinse off the unit with tap water after use in salt water or swimming pool.
- 10) Power and / or charge the built-in rechargeable battery for portable use by connecting the USB cord to a computer USB connection or to an AC outlet using the AC-to-USB cord 5V, 1A power adapter intended for use with the unit.
- 11) Noise and audio distortion may occur when the batteries are nearing end of charge.
- 12) Do **NOT** remove the built-in battery. Do **NOT** remove the grill covers.

LIMITED MANUFACTURER'S WARRANTY:

The EcoRoam 30 is covered by a 1-year limited warranty that covers defects in workmanship and / or materials for a period of 1 year from original purchase date. This warranty does not apply to any products which have been abused, neglected, modified, or used for a purpose other than the one for which they were manufactured. Please refer to the above care and maintenance instructions for suggested care details. The warranty is valid only for

LED Status Indicators

Battery Indicator, Bluetooth,
Wireless Pairing

Control Buttons

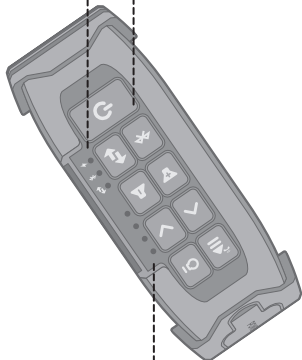

Battery Level Indicators

Control Buttons & Operations

Standby Power

Press the Standby Power Button once to power On/Off.

IMPORTANT: Standby Power function will **NOT** operate when the Master Power is set OFF. Master Power Switch under the cap on the Side Panel must be set ON for Standby & your EcoRoam 30 to operate.

Bluetooth

Once turned on, the EcoRoam 30 will search for your Bluetooth. Refer to **Set Up Recommendations 1-2-3** part **3** for details.

- 2) Never use your ECOXGEAR if you have dropped it or thrown it against a hard surface which may have destroyed the integrity of the speakers, housings, or gaskets. In the event of a severe impact to your unit please return the unit to Grace Digital to review for potential damage.
- 3) Never open the cap in a water environment. This could cause water to ingress into the unit which could potentially be hazardous and cause a fire or a spark.
- 4) Never connect a device to the auxiliary input jack when in a water environment. The auxiliary jack should only be used in a dry environment.
- 5) Never attempt to fix, repair your ECOXGEAR unit. Please send it back to Grace Digital for any assessments and repairs.

CARE, MAINTENANCE, & PRECAUTIONS:

- 1) The unit is waterproof only when the cap is properly closed.
- 2) Close the cap properly before use. If the unit is placed in water without the cap properly closed, water may enter into the unit and void your warranty.
- 3) Dry unit completely before opening the cap. Do **NOT** open the cap if wet or in a wet environment.
- 4) Do **NOT** apply excessive force to any surfaces of the unit when wet or in a wet environment.
- 5) Do **NOT** use or store the unit in places with high temperature.

You should always

- 1) Use the ECOXGEAR speaker in accordance with any music or noise rules and regulations.
- 2) Use the proper ECOXGEAR mounts if you intend to mount the unit.
- 3) Properly seal the ECOXGEAR prior and after each use when in humid or water environments to avoid water damage to the internal components. Salt water / air is particularly corrosive. Always make sure that the gaskets are sealed when in salt water environment and the unit properly rinsed off after use.
- 4) Properly clean the ECOXGEAR and ensure the gaskets have no sand, dirt, or water on them prior to storage or removing the back cover.
- 5) Store your unit with all caps properly sealed to avoid long term internal moisture damage inside your unit.
- 6) Completely dry and clean your ECOXGEAR prior to attempting to charge the unit.
- 7) Return the ECOXGEAR to Grace Digital if you suspect water ingress into the unit or if the unit has experienced a severe impact that may have affected the integrity of the unit to take on water.

You should never

- 1) **NEVER** charge your ECOXGEAR if you suspect water has entered the device. Charging a device with water inside could be potentially hazardous and cause fire or a spark.

Wireless Stereo Pairing Button ↔

This functionality is **ONLY** available with two EcoRoam 30 units. Refer to **Wireless Stereo Pairing of Two Speakers** for details.

Speaker Volume

Press ▶ to decrease or ◀ to increase Speaker Volume.

NOTE: Some Bluetooth devices may require to be manually set for maximum audio level.

Your EcoRoam 30 will beep to indicate when maximum or minimum volume setting is reached.

Track Selection

Press button once to select Previous Song track ◀ & Next Song track ▶.

Play/Pause/ Answer/EcoTalk II[®]

Press button once to pause or play song tracks.

When receiving an incoming phone call, press button once to answer. Press button again to hang up. You can also

PRESS AND HOLD to reject an incoming call.

NOTE: To use the Answer function, the EcoRoam 30 must be paired to your smartphone via Bluetooth.

PRESS AND HOLD the button for two seconds to activate the voice assistant on your device (Siri, OK Google, etc.). Once activated, the speakerphone mic on your EcoRoam 30 will hear your voice commands and transfer them to the voice assistant on your device.

WARNING: Danger of explosion if battery is incorrectly replaced.

ATTENTION: Do **NOT** dispose of in a landfill. Contact Grace Digital at www.gracesupport.com or a certified recycling agent to dispose of the unit.

ATTENTION: AC adapter is a device forming a part of the main plug; therefore, an AC adapter can always be readily disconnected from AC socket-outlet.

SAFETY:

This product has a limited life span of use and should be replaced when it shows obvious signs of wear.

Do not modify or remove any original component parts of the speaker. Doing so could cause damage to the unit allowing water to ingress. A unit with water ingress should not be charged due to potential risk of fire or shock.

Do not attempt to mount the unit except with the approved ECOXGEAR mounts. Doing so could cause damage to the unit allowing water to ingress. A unit with water ingress should not be charged due to potential risk of fire or shock.

Please exercise care and good judgment when using your ECOXGEAR speaker. Audio levels should be appropriate to your environment, comply with all local regulations, and always ensure that you can hear and be aware of any potential hazards around you.

water, clean it thoroughly after use with fresh water.

The USB cables and unit with an improperly fitted cap are **NOT** waterproof.

To prevent fire or shock, do **NOT** attempt to charge this unit if it is wet or you suspect water has entered the unit. In this situation, please return the unit to Grace Digital for a free assessment. If we have found that the unit has carried water, we will repair or replace the unit free of charge.

SAFETY ADVISORY & WARNING:

Read and follow all instructions.

Use only as intended.

- CAUTION:** Do **NOT** open to repair. A qualified technician must carry out repair work.
- ATTENTION:** Do **NOT** charge while the unit is wet. Towel dry the unit **AND** make sure all connections are dry **BEFORE** plugging in the charging connector. Failure to do so may result in electrical damage to the unit and may void the warranty.

PROPOSITION 65

 **WARNING:** Cancer and Reproductive Harm
- www.P65Warnings.ca.gov

WARNING: EcoRoam 30 has a built-in Lithium battery. The battery must **NOT** be used in or near an open heat source or excessive heat.

NOTE: Before using the EcoTalk function, your smartphone must be connected to the EcoRoam 30 via Bluetooth. Not all devices have voice assistant functionality; refer to your device for details.

Party Light Modes

Press button to cycle through 8 modes: Off, White - High, White - Low, Green, Red, Blue, Music Sync, Color Fade.

Battery Indicator

Connect USB to power source. LED on the top panel indicates USB connection charging status.

RED: charge in process

GREEN: full charge complete

NOTE: There also are four LED Battery Level Indicators located on the top of the unit. Each LED represents 25% of a charge. Four full LEDs indicate a full charge.

Set Up

Recommendations 1-2-3

1 Charge Your EcoRoam 30

Before you power on your EcoRoam 30, connect the USB Micro port to the USB cable and a 5V, 1A power source to fully charge your EcoRoam 30 for best performance.

NOTE: Before using your EcoRoam 30 for the first time, charge the unit until all battery level indicators are green, indicating a full charge.

Approximately 3 hrs. of charging is required from a low to a full charge.

Power source options include the USB connection to your computer or a power outlet using a 5V, 1A USB to AC power adapter. It is recommended to always use the USB cable included with your EcoRoam 30.

receiver is connected, consult the dealer or an experienced radio/TV technician for help.

RF WARNING STATEMENT:

The device has been evaluated to meet general RF exposure requirement. The device can be used in portable exposure condition without restriction.

IC STATEMENT:

This device complies with Industry Canada licence-exempt RSS standard(s). Operation is subject to the following two conditions:

- 1) This device may not cause interference, and
- 2) This device must accept any interference, including interference that may cause undesired operation of the device.

PRODUCT USE AND PROTECTION:

Read and follow all instructions.

Use only as intended.

The ECOXGEAR Bluetooth speaker is intended to be used indoors or outdoors and in land or water environments. The speaker has been tested to IP67 waterproofing standards, which means the speaker can be submerged in up to 3 feet of water for 30 minutes without any damage. However, the speaker is **NOT** intended for constant underwater use.

Always make sure the cap(s) / covers(s) are clean, free from sand or debris, and correctly fitted. The speaker will only meet IP67 ratings if all rubber seals, gasket(s), and cover(s) / cap(s) are in place. If you notice a muffling of audio after submersion, gently shake the unit to clear excess water. If your speaker is exposed to salt

FCC STATEMENT:

This device complies with Part 15 of the FCC Rules. Operation is subject to the following two conditions:

- 1) This device may not cause harmful interference, and
- 2) This device must accept any interference received, including interference that may cause undesired operation.

WARNING: Changes or modifications not expressly approved by the party responsible for compliance could void the user's authority to operate the equipment.

NOTE: This equipment has been tested and found to comply with the limits for a Class B digital device, pursuant to Part 15 of the FCC Rules. These limits are designed to provide reasonable protection against harmful interference in a residential installation. This equipment generates, uses, and can radiate radio frequency energy and, if not installed and used in accordance with the instructions, may cause harmful interference to radio communications. However, there is no guarantee that interference will not occur in a particular installation. If this equipment does cause harmful interference to radio or television reception, which can be determined by turning the equipment off and on, the user is encouraged to try to correct the interference by one or more of the following measures: reorient or relocate the receiving antenna, increase the separation between the equipment and receiver, connect the equipment into an outlet on a circuit different from that to which the

2 Power On, Battery, & LED Status Indicators

Once fully charged, press the Standby Power Button  on the top of your EcoRoam 30. You will see the green LED light & you will hear, "Speaker on. Ready to connect." when powering on.

IMPORTANT: Make sure that the Main Power Switch, located in the side compartment under the cap, is set in the ON position. If the switch is in the OFF position, your EcoRoam 30 will not be able to turn on using the Standby Power Button.

The LED battery level indicators are located on the top of the unit. Each bar represents 25% of a charge, with 4 full LEDs indicating a full charge.

Audio playback time over Bluetooth connection is approximately 15 hours.

3 Bluetooth Pairing & Your Audio **Connecting With Bluetooth: Connect To Your Smart Device & Play Audio**

When your EcoRoam 30 is turned on, the LED Bluetooth Status Indicator on the top panel will flash blue, indicating the unit is ready to pair.

Turn on Bluetooth on your Bluetooth device (Smart Device) and set the device in pairing mode. Available Bluetooth connections shall appear. Select the ECOXGEAR speaker from the list of discovered devices on your Bluetooth device. Wait for a few seconds until the connection is completed.

NOTE: Bluetooth connection feature is found in the Settings section of most mobile phones and other Bluetooth enabled devices.

Optional Accessories

For Charging

AC (5V, 1A) USB Wall Outlet
Power Adapter

For Mounting

Suction Cup Mount (¼" mount)
Handlebar Mount Adapter
(¼" mount)

What's in the Box



EcoRoam 30



User Guide



Carabiner



USB Cable

When the ECOXGEAR selection is made and the Bluetooth connection is completed, your EcoRoam 30 will announce, “Your phone is connected.”

Once connected, select and play your desired audio.

Pairing Mode: If the LED is not flashing or if you wish to place your EcoRoam 30 in pairing mode, press and release the Bluetooth button on the top panel. Your EcoRoam 30 shall announce, “Ready to connect” when ready to pair to a new device.

NOTE: Your EcoRoam 30 shall sync & wirelessly pair with most Bluetooth enabled devices. The unit remembers the last device paired and will automatically search for previous connections when the speaker is turned on or when a device comes back into Bluetooth range. If a connection is lost due to range, the speaker

will look to re-establish that connection. If Bluetooth is turned off on your Smart Device, the EcoRoam 30 may not automatically look for the device.

RECOMMENDATION: If you are not familiar with Bluetooth pairing for your smartphone or other Smart Device, refer to the User Guide for your smartphone to learn how to add and pair a new device (EcoRoam 30 for instance) to your smartphone using Bluetooth.

Bluetooth Pairing & Connections: Once paired, should you have an issue switching between Bluetooth connections between devices, open the Bluetooth Section within the device currently connected to the EcoRoam 30 and delete the Bluetooth connection. The EcoRoam 30 will then be available to pair & connect to an alternate Bluetooth enabled smartphone / audio device.

Mount Attachment Point
¼" diameter

Pairing Speakers
Up to 30 ft / 9.1 m between paired speakers

Charging Options
USB cable to USB outlet, to 5V AC adapter, or to Computer

Charging Time
Approximately 3 hours

Recommended Storage (Battery) Temperature
59°F / 15°C

Operating Temperature
23°F to 104°F / -5°C to 40°C

Waterproof/Dustproof Rating
IP67

Unit Weight

15 ounces

Output Power

15W Max Amp,
x1 woofer (Ø3")

S/N Ratio

88dB +/- 3dB

Power Source

3.7V, 2600mAh
Lithium Ion Battery

USB Input

5V, 1A

Frequency Range

125Hz-18,000Hz

Bluetooth

Bluetooth® 4.2
Up to 100 ft / 30 m

Play Time

15+ hours from full charge

Wireless Stereo Pairing of Two Speakers



First Time Pairing Two Speakers:

When you have two EcoRoam 30 speakers and want to wirelessly pair them for stereo sound, power on the two speakers, making sure neither is connected to a phone.

Next, press the Wireless Pairing Button  on both speakers. Each speaker will announce, “Pairing speakers.”

Wait approximately 3-10 seconds for the units to pair. When paired, the speakers will

announce, “Speakers paired,” and the LED Wireless Stereo Pairing Indicator will turn solid blue on both units. Speaker A will announce, “Ready to connect,” indicating that it is ready to pair to your phone.

Pair Speaker A to your phone by selecting ‘ECOXGEAR’ from the list of discovered Bluetooth devices on your smartphone. Once connected, Speaker A will announce, “Your phone is connected.” Once connected, select and play your desired audio.

Re-Pairing Same Two Speakers After Already Paired Once:

Power on the two EcoRoam 30 units. Wait approximately 3-5 seconds and speakers will automatically re-pair to each other.

The speakers will announce,

Specifications

Unit Dimensions

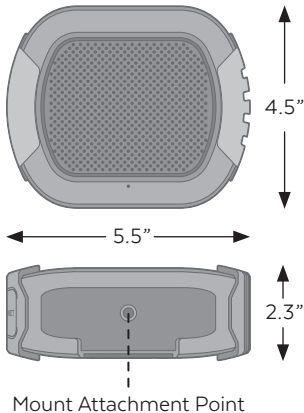

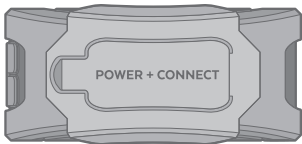

Important: Maintaining Waterproofness

Your EcoRoam 30 is only waterproof when the cap is properly closed. In order to properly close the cap, push firmly to be sure the cap fits flat and flush along the edges with the panel. If not properly closed the unit is **NOT** watertight and may not float.

“Speakers paired” and the LED Indicator will turn solid blue on both units.

To un-pair two paired speakers, **PRESS AND HOLD** the Bluetooth Button  for 5 seconds on either speaker.

NOTES:

- Un-pairing the two speakers by pressing the Bluetooth Button will also clear the Bluetooth pairing records on that speaker.
- The pairing functionality is **ONLY** available with two EcoRoam 30 units with a distance of up to 30ft from each other. It only works when using Bluetooth as your audio source.

Master Power Switch & Connections

Master Power Switch

EcoRoam 30 has a separate Master Power Switch and a Standby Button. The switch **MUST** be set to the ON position to power your EcoRoam 30. Once the switch is set to ON, use the Standby Button located on the Top Panel to turn the unit On/Off.

NOTE: When not in use for extended periods, turn the Master Power off to preserve battery life.

IMPORTANT: Standby Power function will **NOT** operate when the Master Power is set to OFF.



Audio AUX-IN

Connect an audio device using the 3.5mm cable connection as an alternative to a Bluetooth connection to your EcoRoam 30.

NOTE: Volume level must be controlled from the audio device when connected to the AUX-IN connection.

Input

Connect the USB cable to the USB micro Input to charge your EcoRoam 30.

RECOMMENDATION: Use the USB cable included in the box.

NOTE: Charge time from low to full charge is approximately 3 hours.

While playing audio, EcoRoam 30 can be charged.

CAUTION: Do **NOT** charge if unit and/or connections are wet or damp.