

<b>RADIO REPORT</b> <b>FCC 47 CFR Part 15C</b> <b>Digital transmission systems operating within the 2400.0 MHz - 2483.5 MHz band</b>	
<b>Report Reference No</b>	G0M-2112-1231-TFC247BT-V02
<b>Testing Laboratory</b>	Eurofins Product Service GmbH
<b>Address</b>	Storkower Str. 38c 15526 Reichenwalde Germany
<b>Accreditation</b>	 DAkkS - Registration number : D-PL-12092-01-04 (FCC) FCC Filed Test Laboratory, Reg.-No.: 96970
<b>Applicant</b>	eResearchTechnology GmbH
<b>Address</b>	Sieboldstrasse 3 97230 Estenfeld Germany
<b>Test Specification</b>	47 CFR Part 15C
<b>Non-Standard Test Method</b>	None
<b>Equipment under Test (EUT):</b>	
<b>Product Description</b>	Spirometer System
<b>Model(s)</b>	SpiroSphere
<b>Additional Model(s)</b>	None
<b>Brand Name(s)</b>	None
<b>Hardware Version(s)</b>	N7 (12.07.06)
<b>Software Version(s)</b>	SpiroSpherePackage V4.6.5 Jet_Lib + TestAPP 1.0.0
<b>FCC ID</b>	2AAUFSPS003
<b>Test Result</b>	<b>PASSED</b>

<b>Possible test case verdicts:</b>		
Required by standard but not tested	N/T	
Not required by standard	N/R	
Not applicable to EUT	N/A	
Test object does meet the requirement	P(PASS)	
Test object does not meet the requirement	F(FAIL)	
<b>Testing:</b>		
Test Lab Temperature	20 °C - 30 °C	
Test Lab Humidity	25 % - 55 %	
Date of receipt of test item	2022-02-03	
<b>Report:</b>		
Compiled by	Odai Qawasmeh	
Tested by (+ signature) (Responsible for Test)	Radwan Jaafar	
Approved by (+ signature) (Test Lab Engineer)	Wilfried Treffke	
Date of Issue	2022-09-27	
Total number of pages	34	
<b>General Remarks:</b>		
<p>The test results presented in this report relate only to the object tested.</p> <p>The results contained in this report reflect the results for this particular model and serial number. It is the responsibility of the manufacturer to ensure that all production models meet the intent of the requirements detailed within this report.</p> <p>This report shall not be reproduced, except in full, without the written approval of the Issuing testing laboratory.</p>		
<b>Additional Comments:</b>		

**VERSION HISTORY**

Version History			
Version	Issue Date	Remarks	Revised By
01	2022-05-16	Initial Release	
02	2022-09-27	Replaced document: G0M-2112-1231-TFC247BT-V01 Replaced by: G0M-2112-1231-TFC247BT-V02  Reason: <ul style="list-style-type: none"> <li>- Reference Module test report is added to the clause Test modes.</li> <li>- HW and SW Version changed</li> <li>- Delete ISED (Canada) relevant tests and information. This report version (V02) shall be applicable for FCC (USA) certification only.</li> </ul>	R. Jaafar

**ABBREVIATIONS AND ACRONYMS**

Acronyms	
Acronym	Description
BR	Basic Rate (Bluetooth)
EUT	Equipment Under Test
FCC	Federal Communications Commission
ISED	Innovation, Science and Economic Development Canada
RBW	Resolution bandwidth
RMS	Root mean square
VBW	Video bandwidth
V <sub>NOM</sub>	Nominal supply voltage

**REPORT INDEX**

<b>1</b>	<b>Equipment (Test Item) Under Test.....</b>	<b>6</b>
1.1	Photos – Equipment External.....	7
1.2	Photos – Equipment Internal.....	9
1.3	Support Equipment.....	12
1.4	Test Modes.....	13
1.5	Test Frequencies.....	14
1.6	Sample emission level calculation.....	15
<b>2</b>	<b>Result Summary.....</b>	<b>16</b>
<b>3</b>	<b>Test Conditions and Results.....</b>	<b>17</b>
3.1	Test Conditions and Results - AC powerline conducted emissions.....	17
3.2	Test Conditions and Results - Transmitter radiated emissions.....	21
ANNEX A	Transmitter spurious emissions.....	27

## 1 Equipment (Test Item) Under Test

Description	Spirometer System	
Model	SpiroSphere	
Additional Model(s)	None	
Brand Name(s)	None	
Serial Number(s)	SN: 10010003	Test Sample ID 38262
Hardware Version(s)	N7 (12.07.06)	
Software Version(s)	SpiroSpherePackage V4.6.5 Jet_Lib + TestAPP 1.0.0	
FCC ID	2AAUFSPS003	
Equipment type	End Product	
Radio type	Transceiver	
Assigned frequency bands	2400.0 MHz - 2483.5 MHz	
Radio technology	Bluetooth 4.1	
Modulation	GFSK	
Number of antenna ports	1	
Radio Module	Type	WiFi/Bluetooth module
	Model	WL18 MODGB
	Manufacturer	Texas Instruments
	HW Version	Rev. N
	SW Version	V2.16
	FCC-ID	Z64-WL18SBMOD
Antenna	Type	Integrated antenna
	Model	ANT016008LCD2442MA1
	Manufacturer	TDK
	Gain	2.4 dBi
Supply Voltage	V <sub>NOM</sub>	120 VAC
Operating Temperature	T <sub>NOM</sub>	25 °C
AC/DC-Adaptor	Model	GTM91099-3009-4.0-T2
	Vendor	GlobTek
	Input	100 to 240VAC /50/60Hz
	Output	5 VDC
Manufacturer	eResearchTechnology GmbH Sieboldstrasse 3 97230 Estenfeld Germany	

1.1 Photos – Equipment External

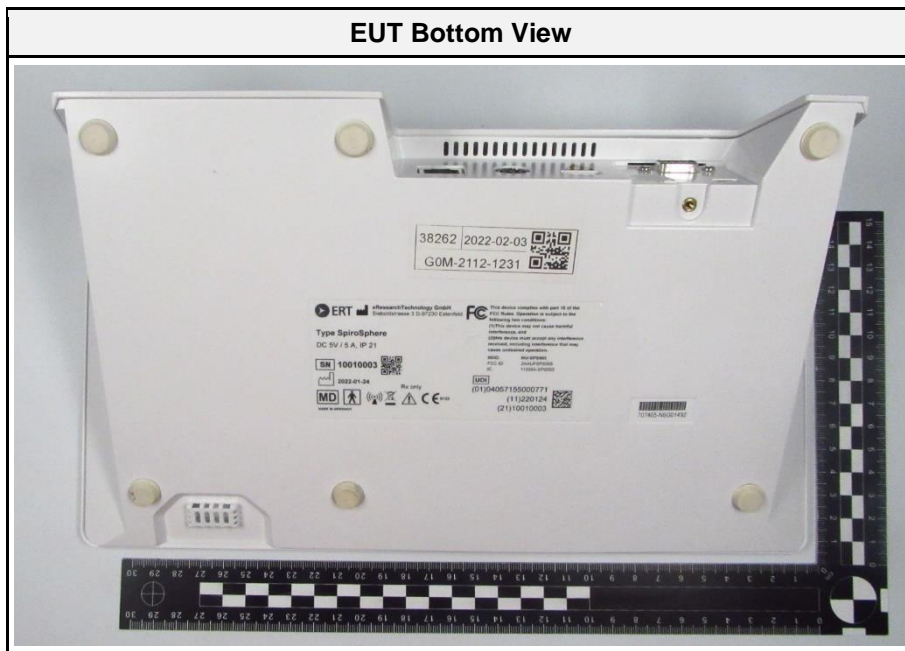
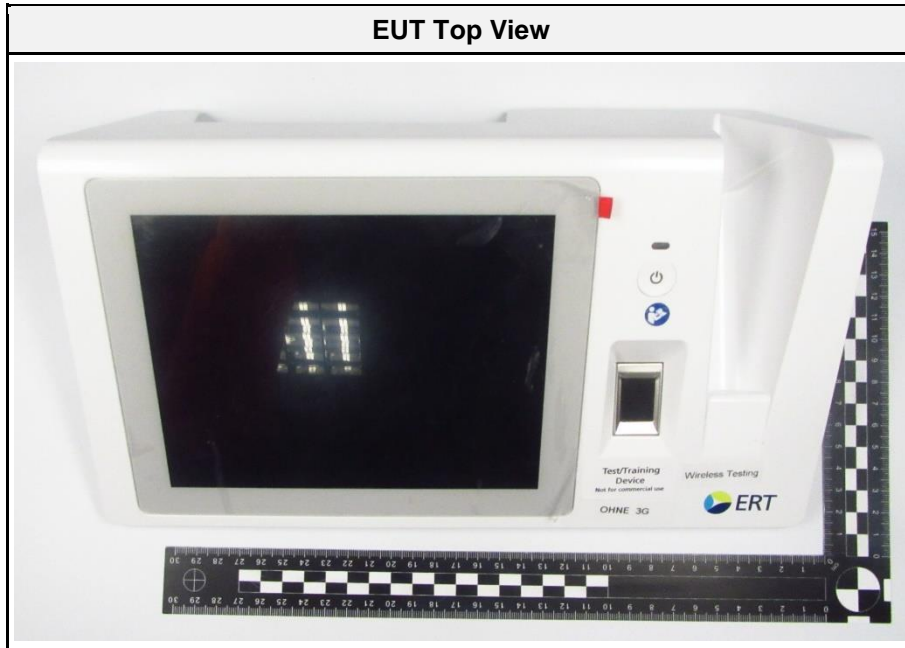

**EUT Ports**



**EUT Side View (left)**



**EUT Side View (right)**

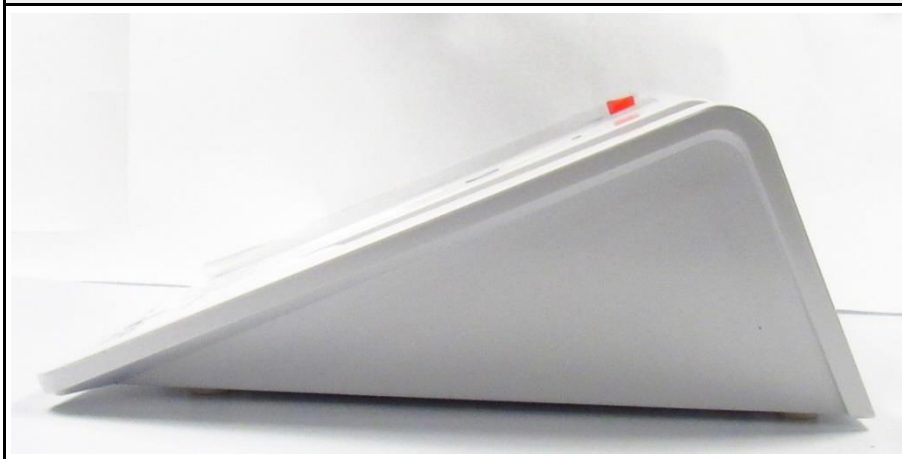



## 1.2 Photos – Equipment Internal

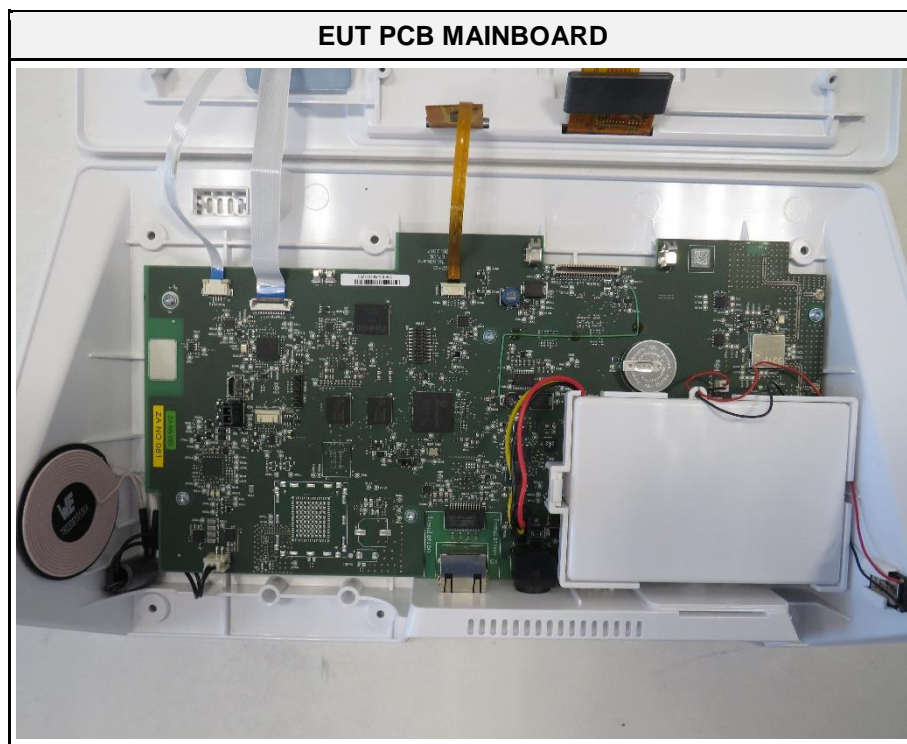
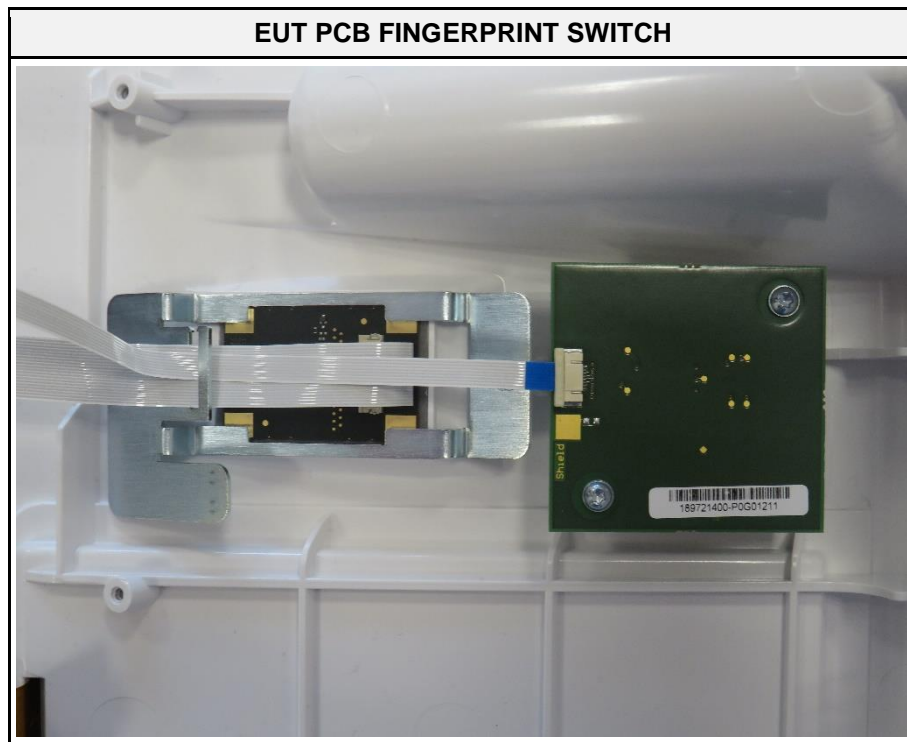

EUT PCB MAINBOARD FOCUS 1

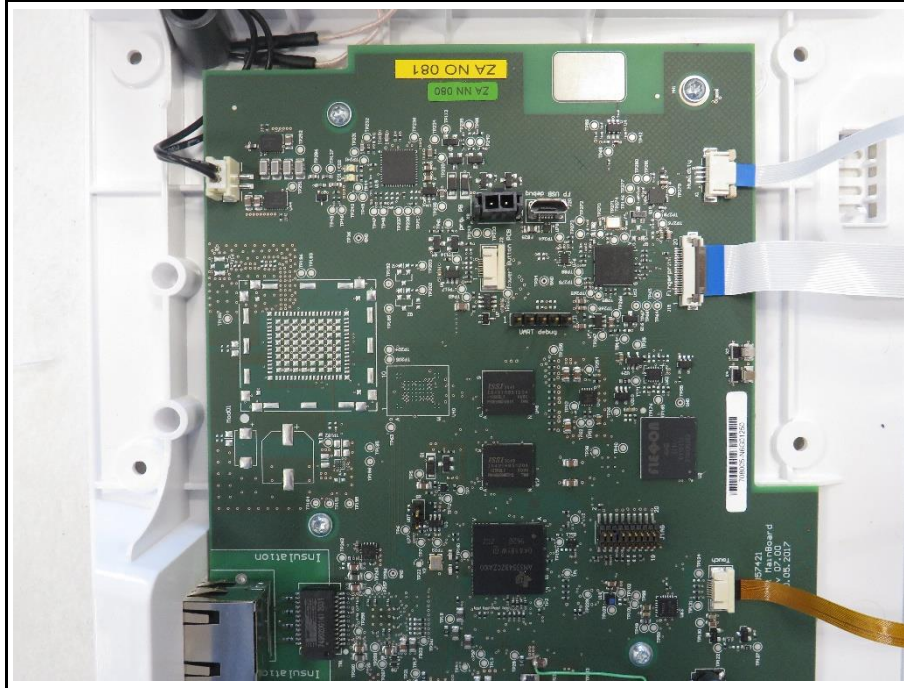

EUT PCB MAINBOARD FOCUS 2



**EUT WITH OPEN COVER**

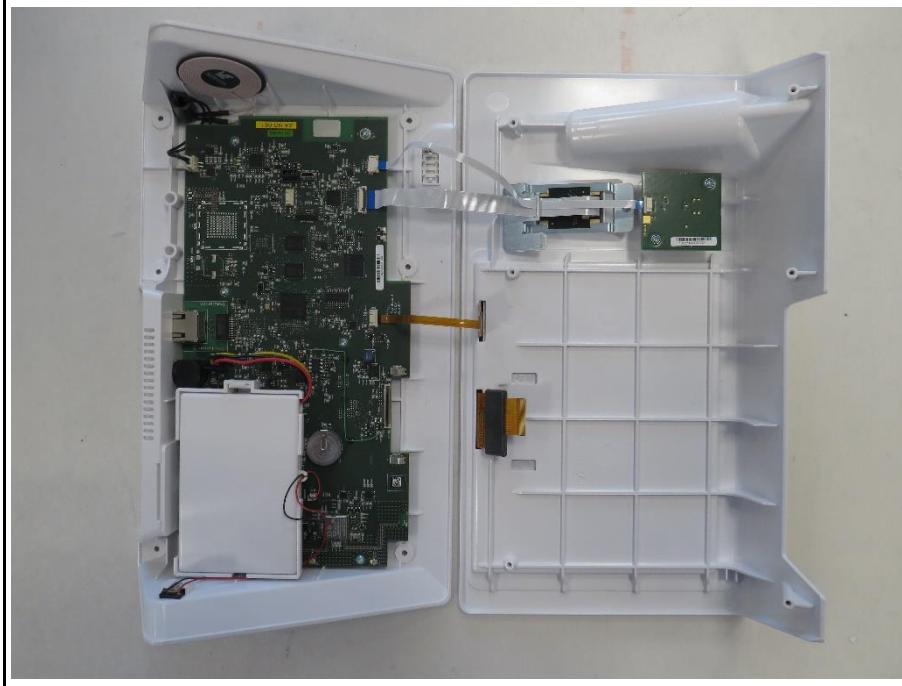

**EUT WITH OPEN COVER FOCUS**



### 1.3 Support Equipment

Product Type	Device	Manufacturer	Model	Comment
AE	Medical ITE Power Supply	GlobTek	GTM91099-3009-4.0-T2	Medical Grad Wall-plug
CBL	WiFi-BT Stecker	-	-	USB to WiFi-BT connector
SFT	Laptop	Dell	DELT0671	With control SW: HTCI tester for BT and RTTT for WiFi
Description:				
AE	Auxiliary Equipment			
SIM	Simulator			
CBL	Connecting Cable			
SFT	Software			
Comment:				

#### 1.4 Test Modes

Mode	Description
DH5 Single	Mode = Transmit Modulation = GFSK Spreading = None Packet type = DH5 Channel = 0 (2402 MHz) Duty cycle = 78%
Comment: The above settings were found as worst case by evaluation of the original radio module test report FR741320A issued by Sporton International Inc. on Feb. 07, 2018. Determination of worst case is based on peak conducted output power from the original test report.	

### 1.5 Test Frequencies

Designator	Mode	Channel	Frequency [MHz]
F1	Tx	0	2402
F2	Tx	39	2480

### 1.6 Sample emission level calculation

The following is a description of terms and a sample calculation, as appears in the radiated emissions data table. The numbers used in the calculation are for example only. There is no direct correlation to the specific data taken for the product described in this document:

Reading:

This is the reading obtained on the spectrum analyzer in dB $\mu$ V. Any external preamplifiers used are taken into account through internal analyzer settings.

A.F.:

This is the antenna factor for the receiving antenna. It is a conversion factor, which converts electric fields strengths to voltages, which can be measured directly on the spectrum analyzer. It is treated as a loss in dB. Cable losses have been included with the A.F. to simplify the calculations. The antenna factor is used in calculations as follows:

$$\text{Reading on Analyzer (dB}\mu\text{V)} + \text{A.F. (dB/m)} = \text{Net field strength (dB}\mu\text{V/m)}$$

Net:

This is the net field strength measurement (as shown above).

Limit:

This is the FCC Class B radiated emission limit (in units of dB $\mu$ V/m). The FCC limits are given in units of  $\mu$ V/m. The following formula is used to convert the units of  $\mu$ V/m to dB $\mu$ V/m:

$$\text{Limit (dB}\mu\text{V/m)} = 20 \cdot \log(\mu\text{V/m})$$

Margin:

This is the margin of compliance below the FCC limit. The units are given in dB. A negative margin indicates the emission was below the limit. A positive margin indicates that the emission exceeds the limit.

Example only:

Reading + AF	=	Net Reading	:	Net reading - FCC limit	=	Margin
+21.5 dB $\mu$ V + 26 dB/m		= 47.5 dB $\mu$ V/m		47.5 dB $\mu$ V/m - 57.0 dB $\mu$ V/m		= -9.5 dB

## 2 Result Summary

FCC 47 CFR Part 15C				
Product Standard Reference	Requirement	Reference Method	Result	Remarks
FCC § 15.247(a)(1)	20 dB Bandwidth	ANSI C63.10-2013	N/T	Note 1
FCC § 15.247(a)(1)(iii)	Number of hopping frequencies	ANSI C63.10-2013	N/T	Note 1
FCC § 15.247(a)(1)	Frequency hopping channel separation	ANSI C63.10-2013	N/T	Note 1
FCC § 15.247(a)(1)(iii)	Time of occupancy (Dwell time)	ANSI C63.10-2013	N/T	Note 1
FCC § 15.247(b)	Maximum peak conducted power	ANSI C63.10-2013	N/T	Note 1
FCC § 15.207	AC power line conducted emissions	ANSI C63.10-2013	PASS	Note 1
FCC § 15.247(d)	Band edge compliance	ANSI C63.10-2013	N/T	Note 1
FCC § 15.247(d)	Conducted spurious emissions	ANSI C63.10-2013	N/T	Note 1
FCC § 15.247(d) FCC § 15.209	Transmitter radiated spurious emissions	ANSI C63.10-2013	PASS	Note 1
Note 1: Due to the integration of a pre-certified module, only partial and spot check tests were performed with reference to the original test report FR741320A issued by Sporton International Inc. on Feb. 07, 2018.				
Comment: The Decision Rule is applied on the basis of ETSI TR 102 273 and ETSI TR 100 028. These standards provide guidance on how to calculate and apply measurement uncertainty whilst providing maximum uncertainties allowance. In all cases due consideration will be given to ILAC-G8:09/2019. Where a result is considered conditional in respect of its proximity to the limit line, the customer would be made aware of situation so that they can make an informed decision on how to proceed.				

Possible Test Case Verdicts	
PASS	Test object does meet the requirements
FAIL	Test object does not meet the requirements
N/T	Required by standard but not tested
N/R	Not required by standard for the test object



### 3 Test Conditions and Results

#### 3.1 Test Conditions and Results - AC powerline conducted emissions

##### 3.1.1 Information

Test Information	
Reference	FCC § 15.207
Measurement Method	ANSI C63.10 6.2
Measurement Uncertainty	± 3.82 dB
Operator	Odai Qawasmeh
Date	2022-03-18

##### 3.1.2 Limits

Limits		
Frequency [MHz]	Quasi-Peak [dBµV]	Average [dBµV]
0.15 - 0.5	66 - 56*	56 - 46*
0.5 - 5	56	46
5 - 30	60	50

\* Limit decreases linearly with the logarithm of the frequency

##### 3.1.3 Setup

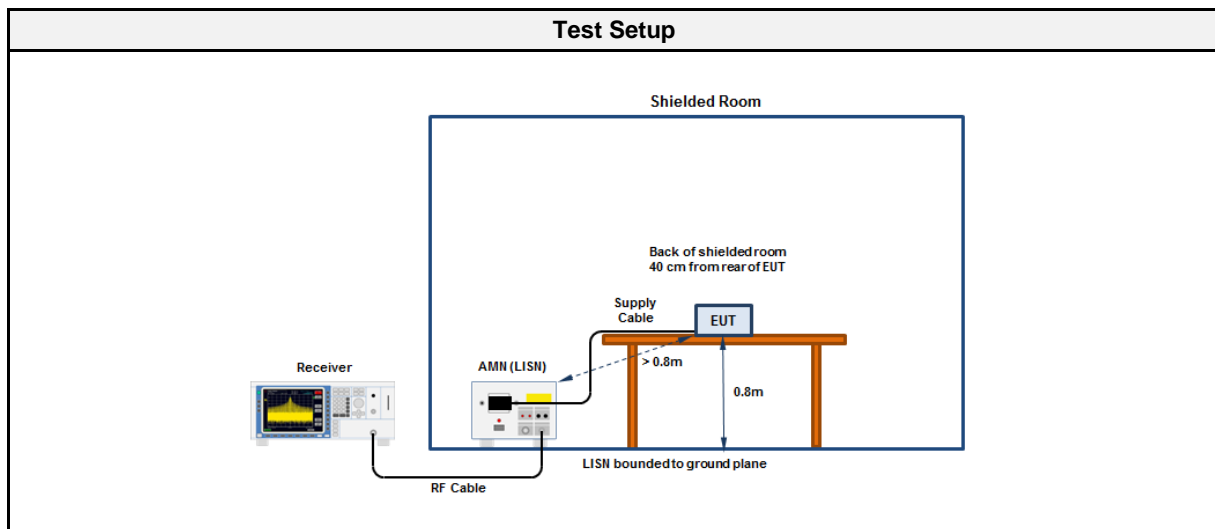

##### 3.1.4 Equipment

Test Software			
Description	Manufacturer	Name	Version
EMC Software	DARE Instruments	RadiMation	2020.1.8

Test Equipment					
Description	Manufacturer	Model	Identifier	Cal. Date	Cal. Due
EMI Test Receiver	R&S	ESR7	EF00943	2021-08	2022-08
Pulse Limiter	R&S	ESH3-Z2	EF01222	2021-07	2022-07
LISN	Schwarzbeck	NSLK 8127 RC	EF01592	2021-07	2022-07

3.15 Setup Photos

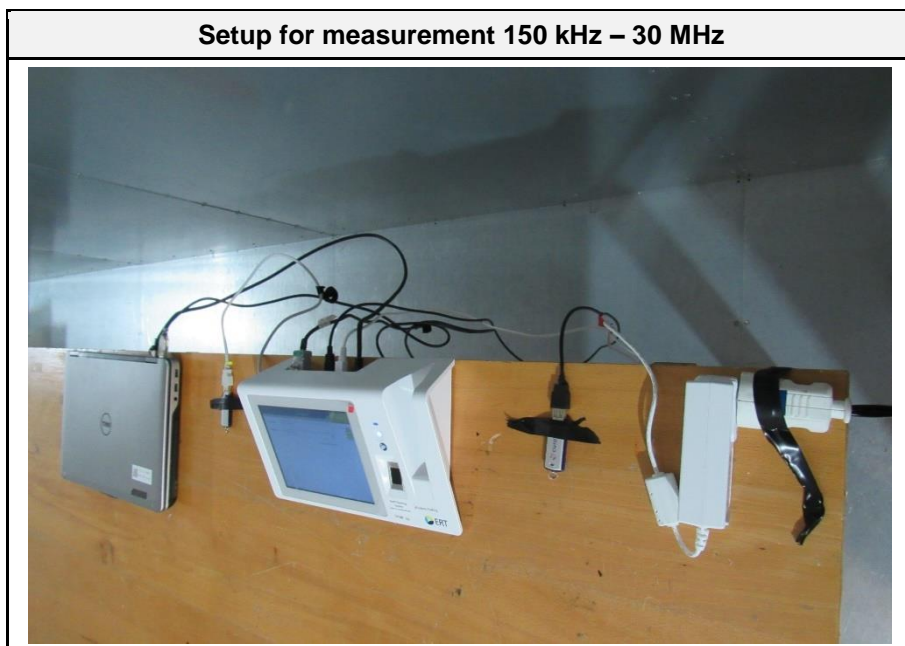
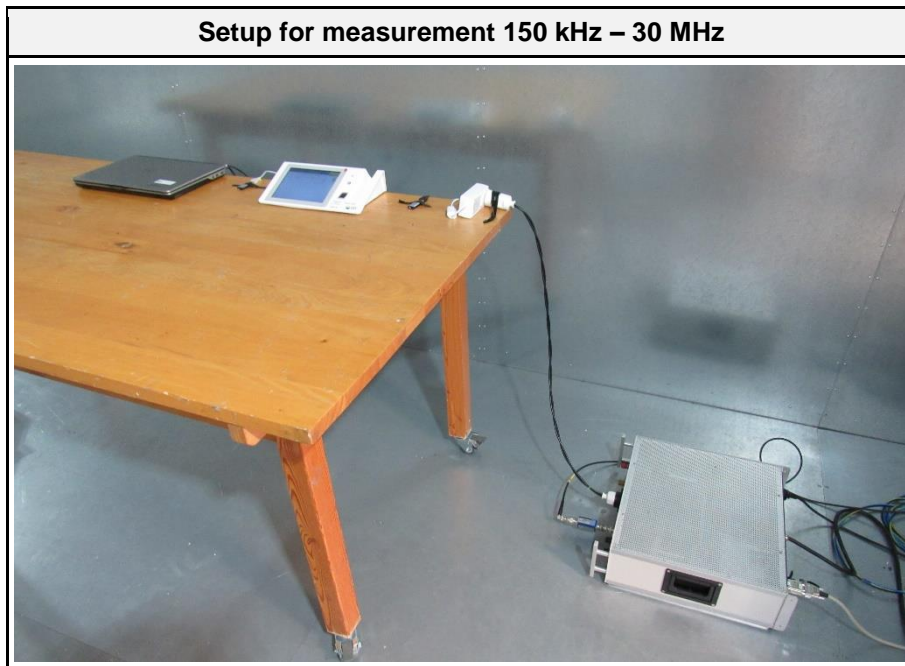

**Conducted emissions at the mains power port according to 47 CFR § 15.207**

Project Number: G0M-2112-1231  
 Applicant: eResearchTechnology GmbH  
 Model Description: Spirometer System  
 Model: SpiroSphere  
 Test Sample ID: 38262  
 Test Site: Eurofins Product Service GmbH  
 Operator: Mr. Qawasmeh  
 Test Date: 2022-03-18  
 Operating Conditions: ambient temperature: 20 °Celsius  
 power input:  
 LISN: Schwarzbeck NSLK 8127 RC L  
 Operational Mode: BT classic, Ch 0, GFSK, 1-DH5  
 EUT Configuration:  
 Applied to Port: AC/DC Adapter to EUT (120V/60Hz to 5 VDC)  
 Note 1:

Index 75

**RadiMation**

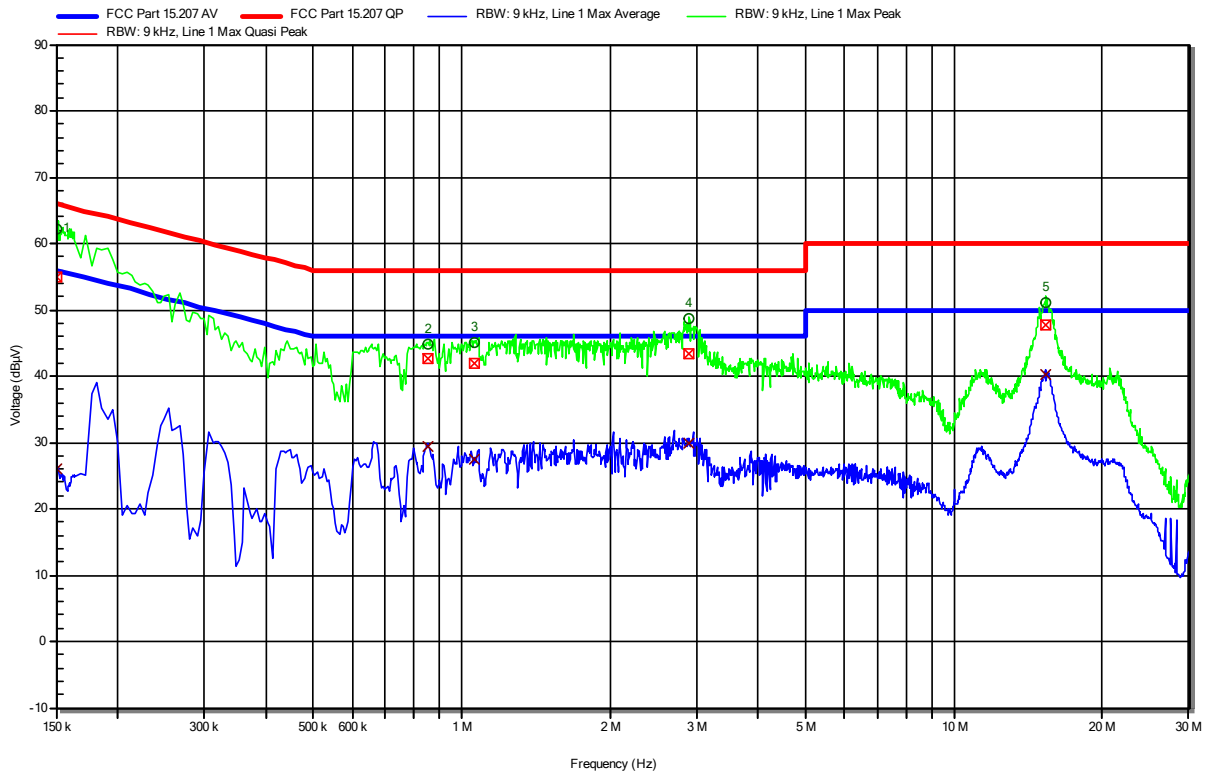

Peak Number	Frequency	Quasi-Peak	Quasi-Peak Limit	Quasi-Peak Difference	Quasi-Peak Status	LISN
1	150 kHz	55.03 dBµV	66 dBµV	-10.97 dB	Pass	Line 1
2	852 kHz	42.7 dBµV	56 dBµV	-13.3 dB	Pass	Line 1
3	1.063 MHz	42.03 dBµV	56 dBµV	-13.97 dB	Pass	Line 1
4	2.9 MHz	43.29 dBµV	56 dBµV	-12.71 dB	Pass	Line 1
5	15.36 MHz	47.8 dBµV	60 dBµV	-12.2 dB	Pass	Line 1

Peak Number	Frequency	Average	Average Limit	Average Difference	Average Status	LISN
1	150 kHz	26.06 dBµV	56 dBµV	-29.94 dB	Pass	Line 1
2	852 kHz	29.31 dBµV	46 dBµV	-16.69 dB	Pass	Line 1
3	1.063 MHz	27.5 dBµV	46 dBµV	-18.5 dB	Pass	Line 1
4	2.9 MHz	29.83 dBµV	46 dBµV	-16.17 dB	Pass	Line 1
5	15.36 MHz	40.12 dBµV	50 dBµV	-9.88 dB	Pass	Line 1

Test Report No.: G0M-2112-1231-TFC247BT-V02

Eurofins Product Service GmbH  
 Storkower Str. 38c, D-15526 Reichenwalde, Germany

**Conducted emissions at the mains power port according to 47 CFR § 15.207**

Project Number: G0M-2112-1231  
 Applicant: eResearchTechnology GmbH  
 Model Description: Spirometer System  
 Model: SpiroSphere  
 Test Sample ID: 38262  
 Test Site: Eurofins Product Service GmbH  
 Operator: Mr. Qawasmeh  
 Test Date: 2022-03-18  
 Operating Conditions: ambient temperature: 20 °Celsius  
 power input:  
 LISN: Schwarzbeck NSLK 8127 RC N  
 Operational Mode: BT classic, Ch 0, GFSK, 1-DH5  
 EUT Configuration:  
 Applied to Port: AC/DC Adapter to EUT (120V/60Hz to 5 VDC)  
 Note 1:

Index 76

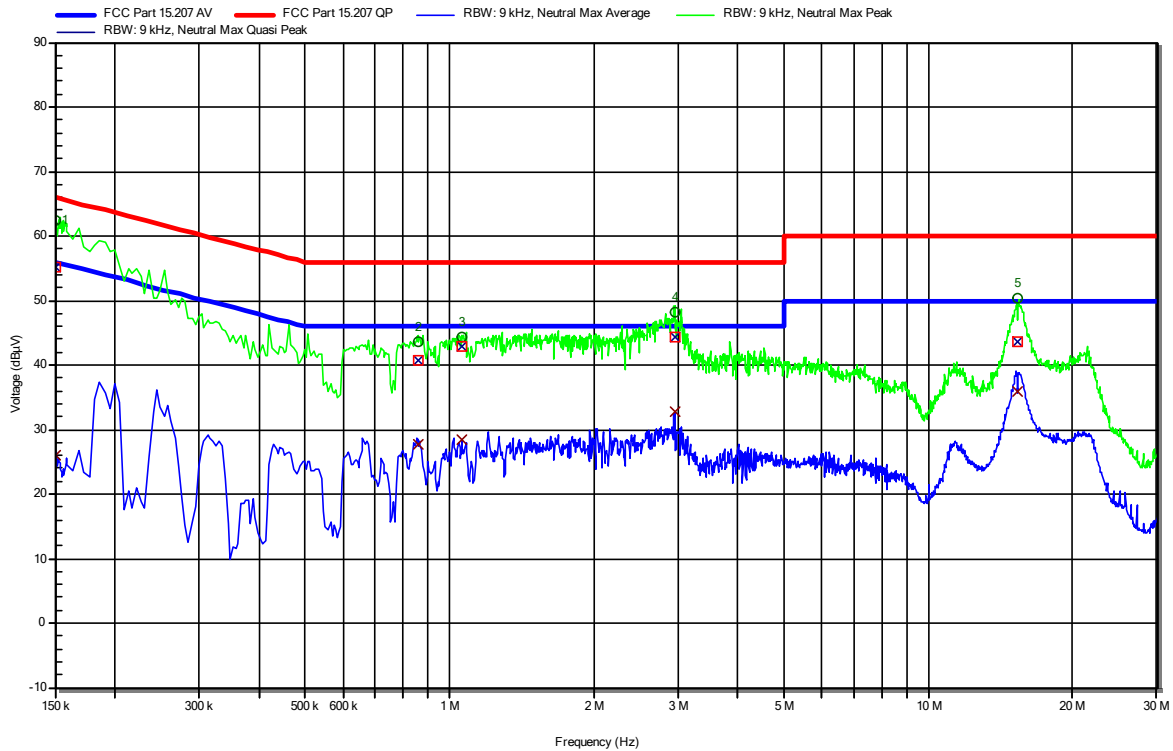

Peak Number	Frequency	Quasi-Peak	Quasi-Peak Limit	Quasi-Peak Difference	Quasi-Peak Status	LISN
1	150 kHz	55.13 dBµV	66 dBµV	-10.87 dB	Pass	Neutral
2	861 kHz	40.8 dBµV	56 dBµV	-15.2 dB	Pass	Neutral
3	1.063 MHz	42.83 dBµV	56 dBµV	-13.17 dB	Pass	Neutral
4	2.949 MHz	44.44 dBµV	56 dBµV	-11.56 dB	Pass	Neutral
5	15.356 MHz	43.66 dBµV	60 dBµV	-16.34 dB	Pass	Neutral
Peak Number	Frequency	Average	Average Limit	Average Difference	Average Status	LISN
1	150 kHz	26.02 dBµV	56 dBµV	-29.98 dB	Pass	Neutral
2	861 kHz	27.79 dBµV	46 dBµV	-18.21 dB	Pass	Neutral
3	1.063 MHz	28.47 dBµV	46 dBµV	-17.53 dB	Pass	Neutral
4	2.949 MHz	32.81 dBµV	46 dBµV	-13.19 dB	Pass	Neutral
5	15.356 MHz	35.95 dBµV	50 dBµV	-14.05 dB	Pass	Neutral

Test Report No.: G0M-2112-1231-TFC247BT-V02

Eurofins Product Service GmbH  
 Storkower Str. 38c, D-15526 Reichenwalde, Germany

### 3.2 Test Conditions and Results - Transmitter radiated emissions

#### 3.2.1 Information

Test Information	
Reference	FCC § 15.247(d); FCC § 15.209
Measurement Uncertainty	± 5.95 dB
Measurement Method	ANSI C63.10 6.4, 6.5, 6.6
Operator	Radwan Jaafar
Date	2022-02-25

#### 3.2.2 Limits

Limits			
Frequency range [MHz]	Detector	Field strength [ $\mu$ V/m]	Measurement distance [m]
0.009 - 0.09	Average	2400/F[kHz]	300
0.09 - 0.110	Quasi-Peak	2400/F[kHz]	300
0.110 - 0.490	Average	2400/F[kHz]	300
0.490 - 1.705	Quasi-Peak	24000/F[kHz]	30
1.705 - 30.0	Quasi-Peak	30	30
30 - 88	Quasi-Peak	100	3
88 - 216	Quasi-Peak	150	3
216 - 960	Quasi-Peak	200	3
960 - 1000	Quasi-Peak	500	3
>1000	Average	500	3

### 3.2.3 Setup

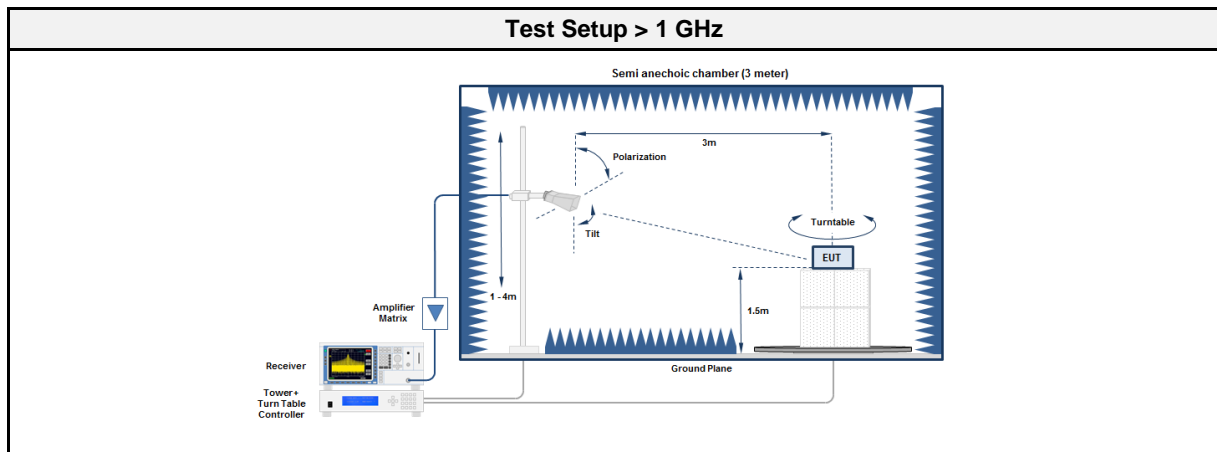
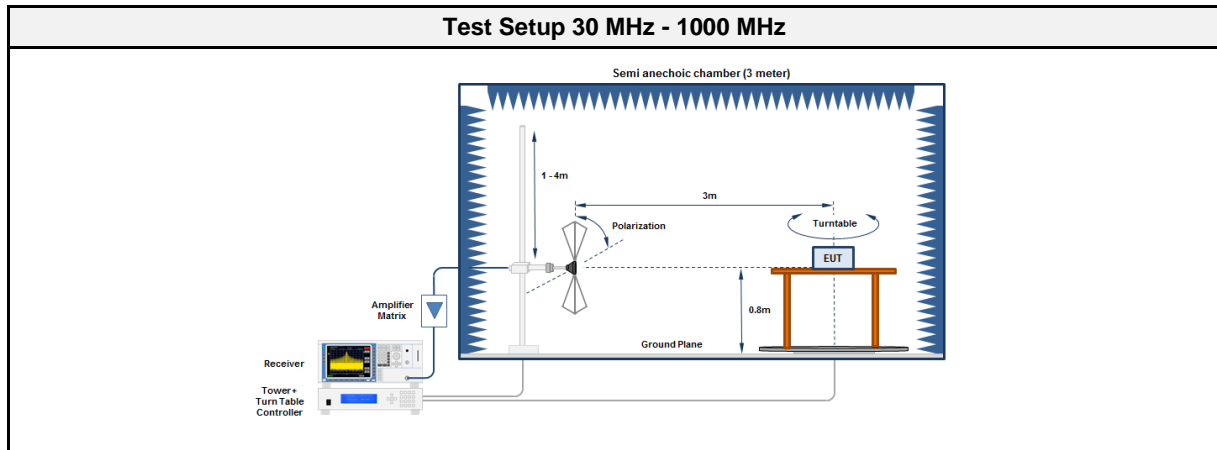

### 3.2.4 Equipment

Test Software			
Description	Manufacturer	Name	Version
EMC Software	DARE Instruments	RadiMation	2020.1.8

Test Equipment 30 - 1000 MHz					
Description	Manufacturer	Model	Identifier	Cal. Date	Cal. Due
Anechoic Chamber	Frankonia	AC1	EF00910	-	-
MXE EMI Receiver	Keysight Technologies	N9038A-526/WXP	EF01070	2021-07	2022-07
Biconical antenna	R&S	HK116	EF00030	2021-05	2024-05
LPD antenna	R&S	HL223	EF00187	2019-05	2022-05

Test Equipment > 1 GHz					
Description	Manufacturer	Model	Identifier	Cal. Date	Cal. Due
Anechoic chamber	Frankonia	AC2	EF00196	-	-
Spectrum analyzer	R&S	FSU43	EF01631	2021-07	2022-07
Antenna	Schwarzbeck	BBHA 9120B	EF01678	2021-03	2022-03
Antenna	Schwarzbeck	HWRD 650	EF01679	2021-03	2022-03
40GHz High Gain Antenna	Amplifier Research	AT4560	EF00302	2021-06	2023-06

3.2.5 Procedure

<b>Test Procedure 30 MHz - 1000 MHz</b>	
1.	EUT is placed on a non conducting support at the center of a turn table 0.8 m above the ground
2.	EUT set to test mode
3.	The receiver is set to peak detection with max hold
4.	The EUT is rotated through 360° and the height of the antenna is varied from 1 m to 4 m
5.	All significant emissions are measured again using the corresponding final detector

<b>Test Procedure &gt; 1 GHz</b>	
1.	EUT is placed on a non conducting support at the center of a turn table 1.5 m above the ground
2.	EUT set to test mode
3.	The receiver is set to peak detection with max hold
4.	The EUT is rotated through 360° and the height of the antenna is varied from 1 m to 4 m
5.	All significant emissions are measured again using the corresponding final detector

3.2.6 Results

<b>Test Results - DH5</b>						
Channel [MHz]	Emission [MHz]	Level [dBµV/m]	Det.	Pol.	Limit [dBµV/m]	Margin [dB]
2402	38.0155	15.80	qpk	ver	40.00	-24.17
2402	73.163	31.40	qpk	ver	40.00	-08.63
2402	134.0697	31.30	qpk	ver	43.50	-12.22
2402	246.2735	44.30	qpk	hor	46.00	-01.69
2402	1513.9	44.92	pk	hor	74.00	-29.08
2402	1513.9	33.11	avg	hor	54.00	-20.89
2402	2379.4	58.83	pk	hor	74.00	-15.17
2402	2379.4	45.13	avg	hor	54.00	-08.87
2402	2724.8	49.82	pk	ver	74.00	-24.18
2402	2724.8	36.64	avg	ver	54.00	-17.36
2402	7322.7	50.88	pk	hor	74.00	-23.12
2402	7322.7	44.77	avg	hor	54.00	-09.23
2402	12010	40.60	pk	hor	74.00	-33.40
2402	12010	32.37	avg	hor	54.00	-21.63

3.2.7 Setup Photos

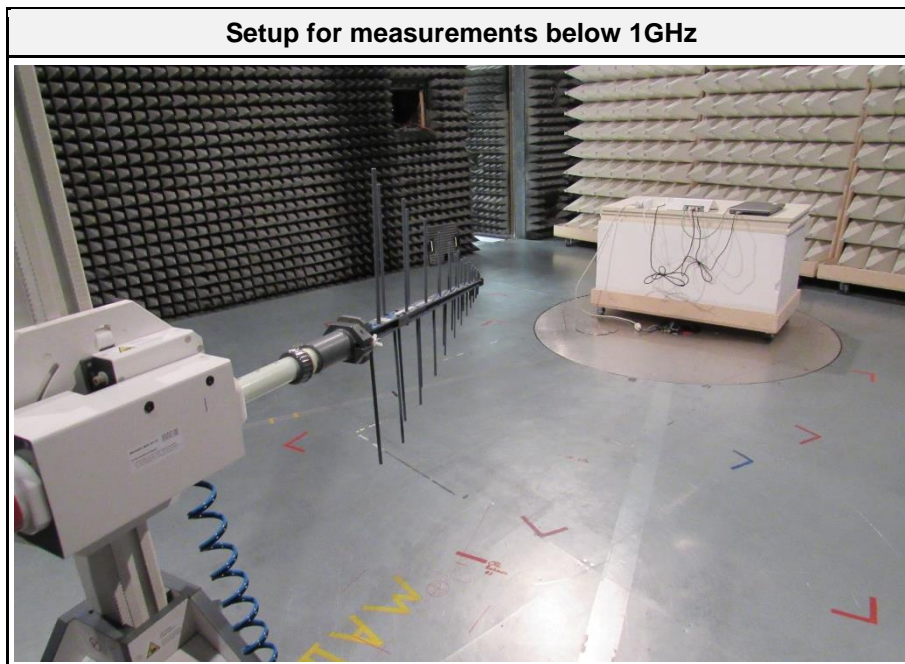
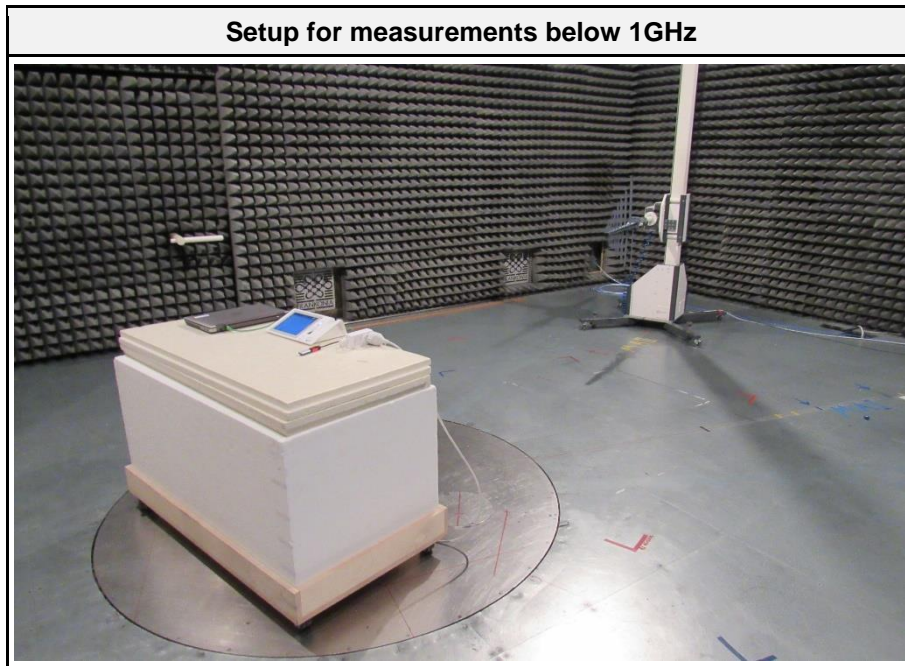



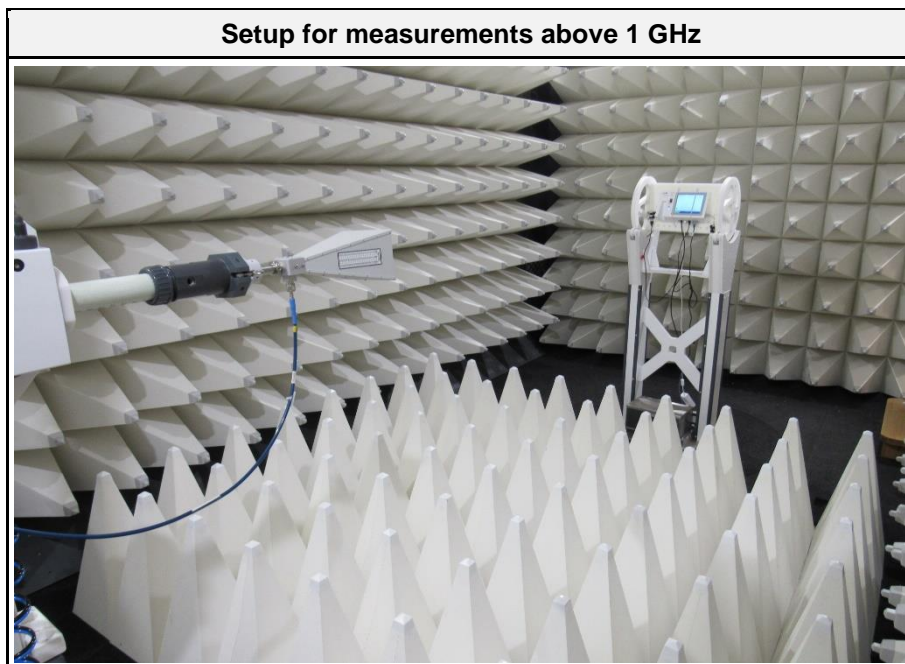
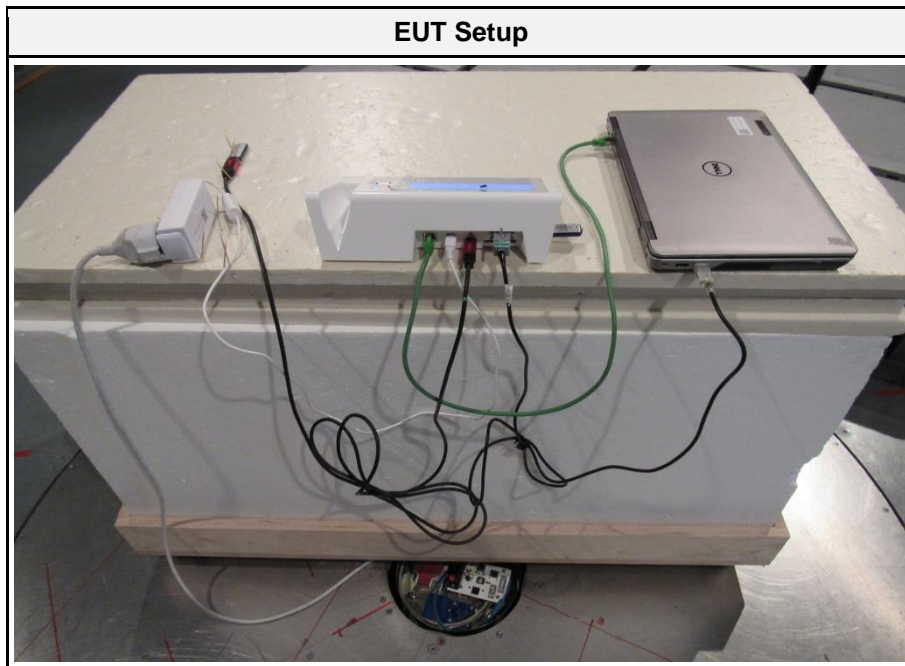

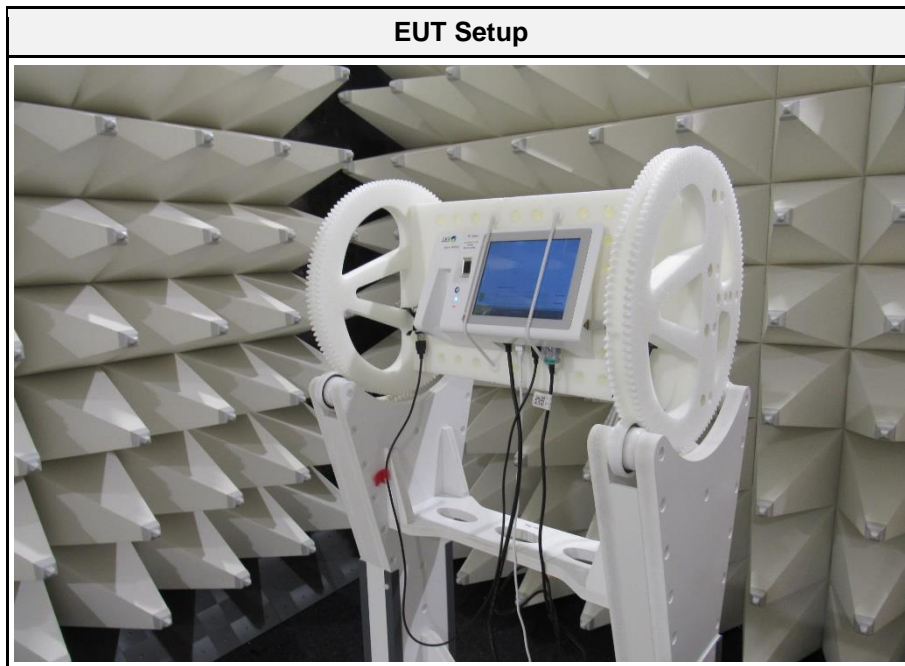

## ANNEX A Transmitter spurious emissions

### Radiated Spurious Emissions according to FCC 15.247

Project Number: G0M-2112-1231  
 Applicant: eResearchTechnology GmbH  
 Model Description: Spirometer System  
 Model: SpiroSphere  
 Test Sample ID: 38262  
 Test Site: Eurofins Product Service GmbH  
 Operator: Mr. Qawasmeh  
 Measurement software: RadiMation, version 2020.1.8  
 Test Conditions: Tnom: 24 °Celsius, Vnom:  
 Antenna: Rohde & Schwarz HK 116  
 Measurement distance: 3 m  
 Mode: Tx; BT classic, Ch 0, GFSK, 1-DH5  
 Test Date: 2022-03-10  
 Note:

Index 73

RadiMation

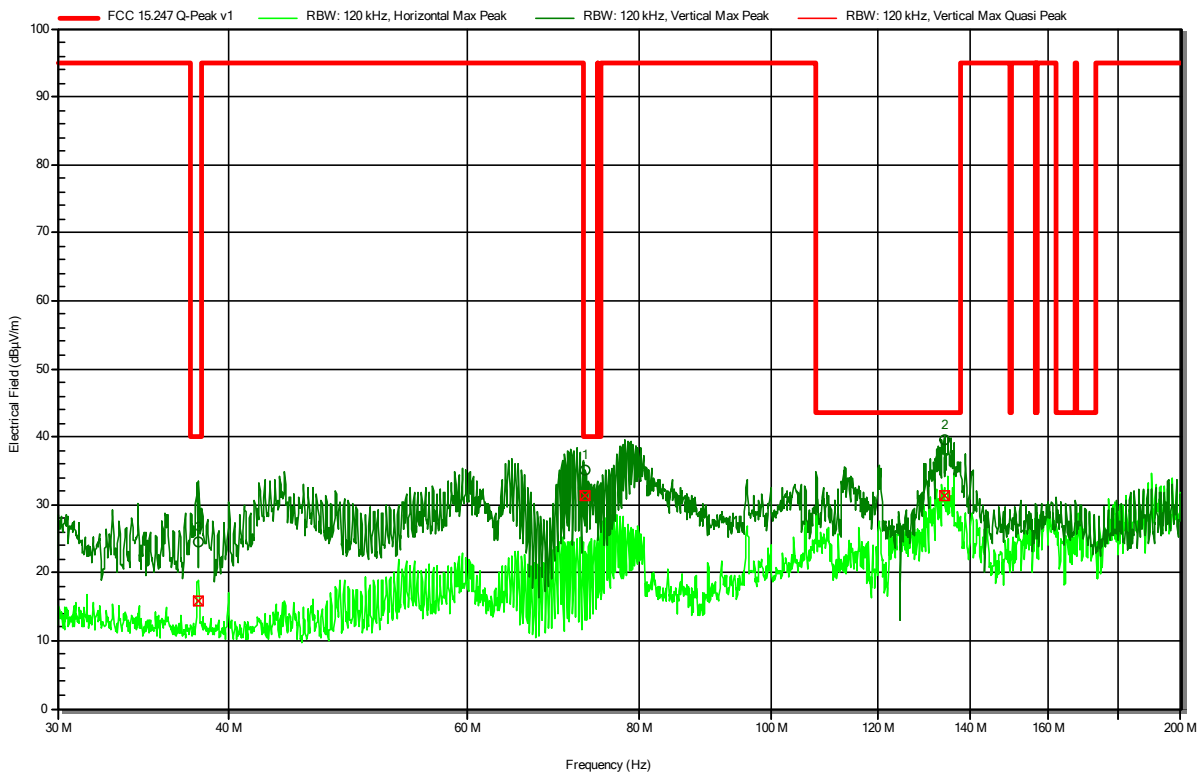

Frequency	Quasi-Peak	Quasi-Peak Limit	Quasi-Peak Difference	Quasi-Peak Status	Polarization
38.0155 MHz	15.8 dBµV/m	40 dBµV/m	-24.17 dB	Pass	Vertical
73.163 MHz	31.4 dBµV/m	40 dBµV/m	-8.63 dB	Pass	Vertical
134.0697 MHz	31.3 dBµV/m	43.5 dBµV/m	-12.22 dB	Pass	Vertical

### Radiated Spurious Emissions according to FCC 15.247

Project Number: G0M-2112-1231  
 Applicant: eResearchTechnology GmbH  
 Model Description: Spirometer System  
 Model: SpiroSphere  
 Test Sample ID: 38262  
 Test Site: Eurofins Product Service GmbH  
 Operator: Mr. Qawasmeh  
 Measurement software: RadiMation, version 2020.1.8  
 Test Conditions: Tnom: 24 °Celsius, Vnom:  
 Antenna: Rohde & Schwarz HL 223  
 Measurement distance: 3 m  
 Mode: Tx; BT classic, Ch 0, GFSK, 1-DH5  
 Test Date: 2022-03-10  
 Note:

Index 74

RadiMation

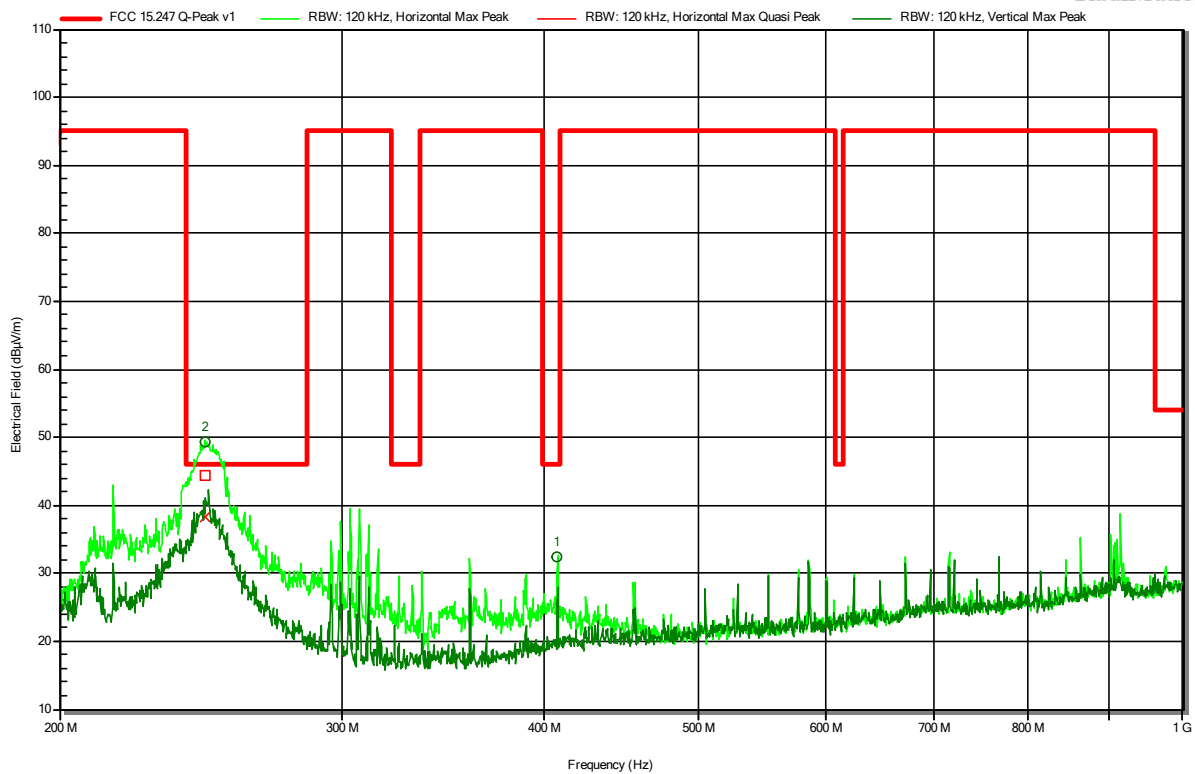

Frequency	Peak	Peak Limit	Peak Difference	Peak Status	Polarization
408.02 MHz	32.4 dBµV/m	46 dBµV/m	-13.57 dB	Pass	Horizontal

Frequency	Quasi-Peak	Quasi-Peak Limit	Quasi-Peak Difference	Quasi-Peak Status	Polarization
246.2735 MHz	44.3 dBµV/m	46 dBµV/m	-1.69 dB	Pass	Horizontal

### Radiated Spurious Emissions according to FCC 15.247

Project Number: G0M-2112-1231  
 Applicant: eResearchTechnology GmbH  
 Model Description: Spirometer System  
 Model: SpiroSphere  
 Test Sample ID: 38262  
 Test Site: Eurofins Product Service GmbH  
 Operator: R. Jaafar  
 Measurement software: RadiMation, version 2020.1.8  
 Test Conditions: Tnom: 24 °Celsius, Vnom:  
 Antenna: Schwarzbeck BBHA 9120B  
 Measurement distance: 3 m  
 Mode: Tx; BT classic, Ch 0, GFSK, 1-DH5  
 Test Date: 2022-02-25  
 Note:

Index 61

RadiMation

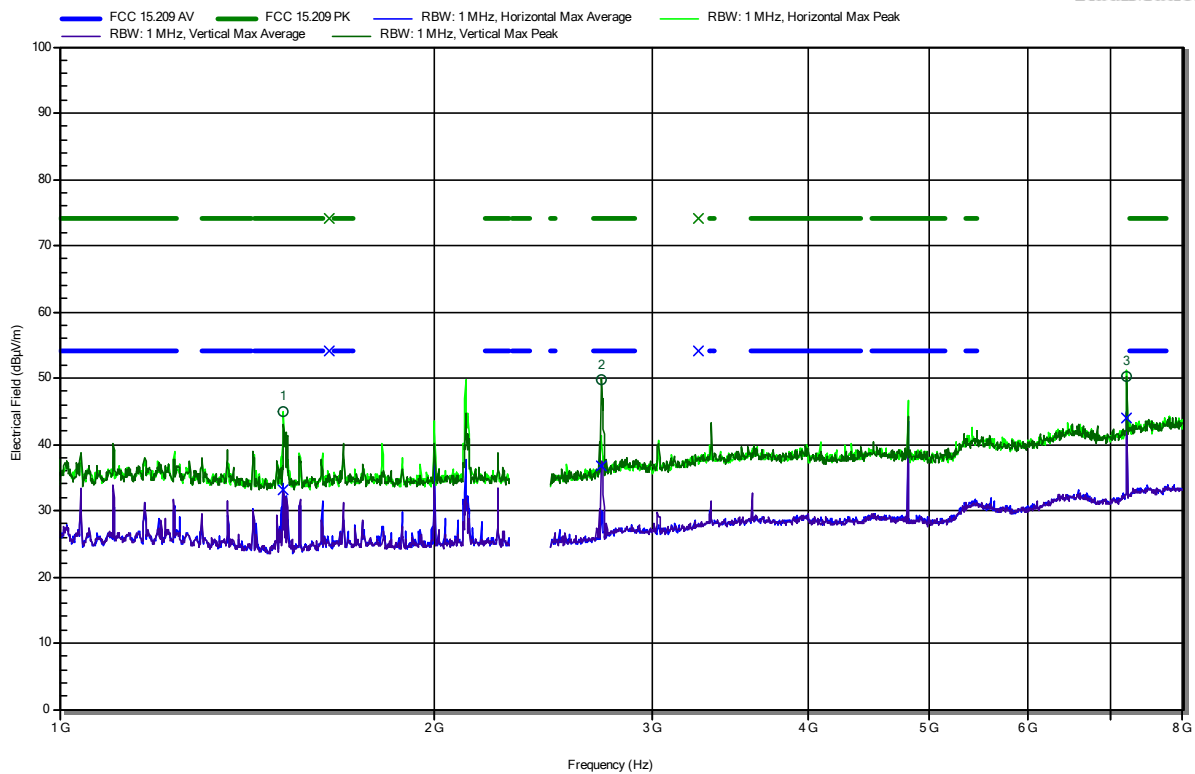

Frequency	Peak	Peak Limit	Peak Difference	Peak Status	Polarization
1.5139 GHz	44.92 dBµV/m	74 dBµV/m	-29.08 dB	Pass	Horizontal
2.7248 GHz	49.82 dBµV/m	74 dBµV/m	-24.18 dB	Pass	Vertical
7.2057 GHz	50.13 dBµV/m				Vertical

Frequency	Average	Average Limit	Average Difference	Average Status	Polarization
1.5139 GHz	33.11 dBµV/m	54 dBµV/m	-20.89 dB	Pass	Horizontal
2.7248 GHz	36.64 dBµV/m	54 dBµV/m	-17.36 dB	Pass	Vertical
7.2057 GHz	44.09 dBµV/m				Vertical

Test Report No.: G0M-2112-1231-TFC247BT-V02

Eurofins Product Service GmbH  
 Storkower Str. 38c, D-15526 Reichenwalde, Germany

### Radiated Spurious Emissions according to FCC 15.247

Project Number: G0M-2112-1231  
 Applicant: eResearchTechnology GmbH  
 Model Description: Spirometer System  
 Model: SpiroSphere  
 Test Sample ID: 38262  
 Test Site: Eurofins Product Service GmbH  
 Operator: R. Jaafar  
 Measurement software: RadiMation, version 2020.1.8  
 Test Conditions: Tnom: 24 °Celsius, Vnom:  
 Antenna: Schwarzbeck BBHA 9120B  
 Measurement distance: 3 m  
 Mode: Tx; BT classic, Ch 78, GFSK, 1-DH5  
 Test Date: 2022-02-25  
 Note: The measurement was performed with the high channel to ensure that the third harmonic doesn't exceed the restricted limit line.

Index 63

**RadiMation**

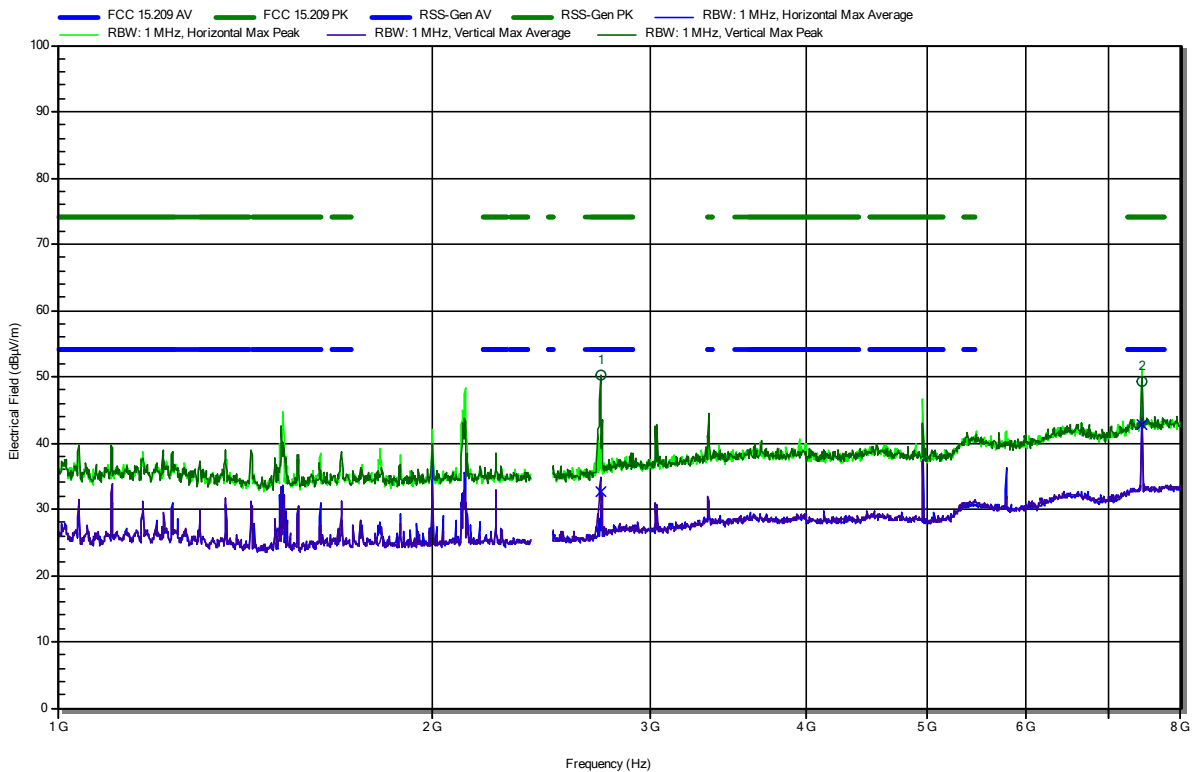

Frequency	Peak	Peak Limit	Peak Difference	Peak Status	Polarization
2.73 GHz	50.17 dBµV/m	74 dBµV/m	-23.83 dB	Pass	Vertical
7.44 GHz	49.35 dBµV/m	74 dBµV/m	-24.65 dB	Pass	Vertical

Frequency	Average	Average Limit	Average Difference	Average Status	Polarization
2.73 GHz	32.73 dBµV/m	54 dBµV/m	-21.27 dB	Pass	Vertical
7.44 GHz	42.69 dBµV/m	54 dBµV/m	-11.31 dB	Pass	Vertical

Test Report No.: G0M-2112-1231-TFC247BT-V02

Eurofins Product Service GmbH  
 Storkower Str. 38c, D-15526 Reichenwalde, Germany

### Radiated Spurious Emissions according to FCC 15.247

Project Number: G0M-2112-1231  
 Applicant: eResearchTechnology GmbH  
 Model Description: Spirometer System  
 Model: SpiroSphere  
 Test Sample ID: 38262  
 Test Site: Eurofins Product Service GmbH  
 Operator: R. Jaafar  
 Measurement software: RadiMation, version 2020.1.8  
 Test Conditions: Tnom: 24 °Celsius, Vnom:  
 Antenna: Schwarzbeck BBHA 9120B  
 Measurement distance: 3 m  
 Mode: Tx; BT classic, Ch 0, GFSK, 1-DH5  
 Test Date: 2022-02-25  
 Note: lower bandedge

Index 62

**RadiMation**

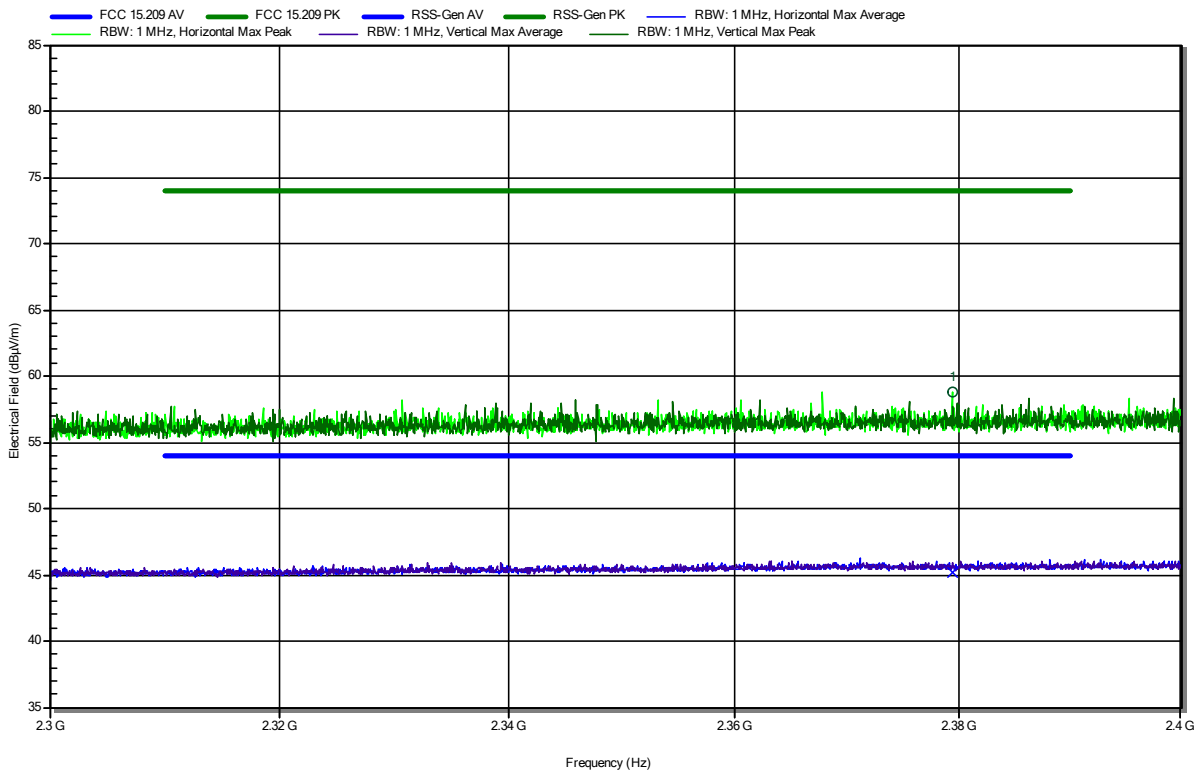

Frequency	Peak	Peak Limit	Peak Difference	Peak Status	Polarization
2.3794 GHz	58.83 dBµV/m	74 dBµV/m	-15.17 dB	Pass	Horizontal
Frequency	Average	Average Limit	Average Difference	Average Status	Polarization
2.3794 GHz	45.13 dBµV/m	54 dBµV/m	-8.87 dB	Pass	Horizontal

### Radiated Spurious Emissions according to FCC 15.247

Project Number: G0M-2112-1231  
 Applicant: eResearchTechnology GmbH  
 Model Description: Spirometer System  
 Model: SpiroSphere  
 Test Sample ID: 38262  
 Test Site: Eurofins Product Service GmbH  
 Operator: R. Jaafar  
 Measurement software: RadiMation, version 2020.1.8  
 Test Conditions: Tnom: 24 °Celsius, Vnom:  
 Antenna: Schwarzbeck BBHA 9120B  
 Measurement distance: 3 m  
 Mode: Tx; BT classic, Ch 78, GFSK, 1-DH5  
 Test Date: 2022-02-25  
 Note: upper bandedge

Index 65

**RadiMation**

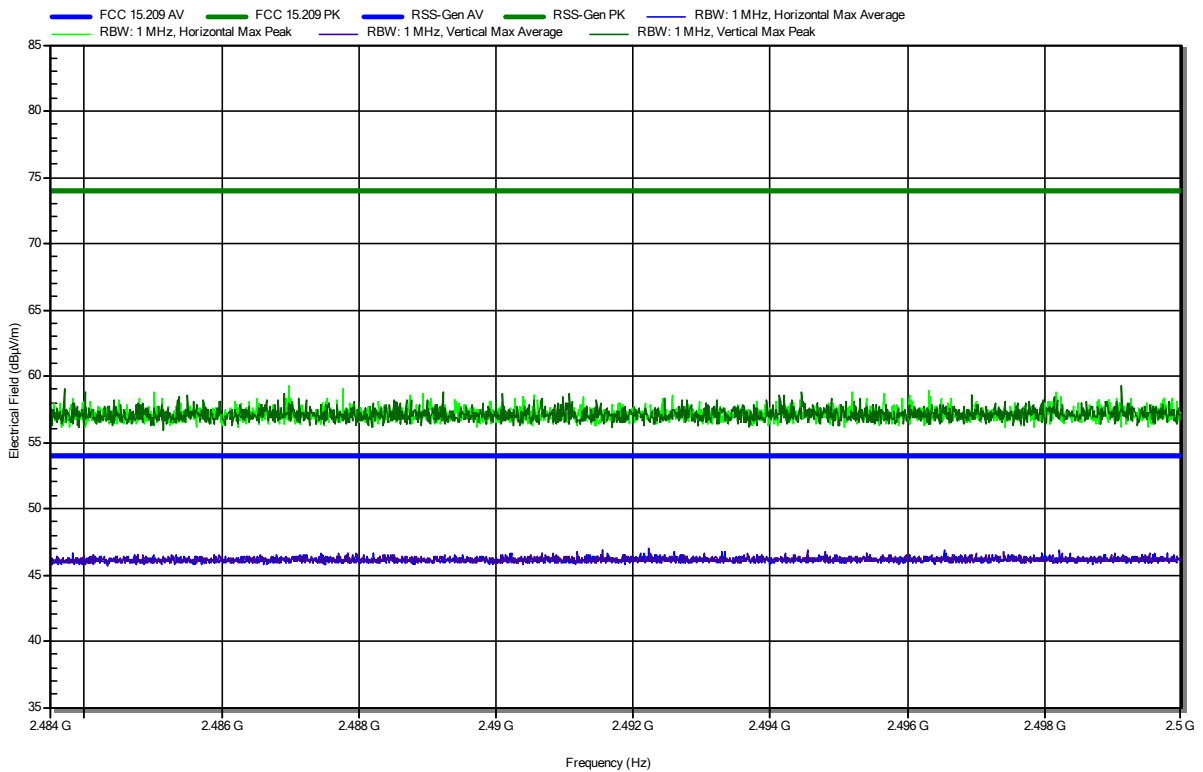



### Radiated Spurious Emissions according to FCC 15.247

Project Number: G0M-2112-1231  
 Applicant: eResearchTechnology GmbH  
 Model Description: Spirometer System  
 Model: SpiroSphere  
 Test Sample ID: 38262  
 Test Site: Eurofins Product Service GmbH  
 Operator: R. Jaafar  
 Measurement software: RadiMation, version 2020.1.8  
 Test Conditions: Tnom: 24 °Celsius, Vnom:  
 Antenna: Schwarzbeck HWRD 650  
 Measurement distance: 3 m  
 Mode: Tx; BT classic, Ch 0, GFSK, 1-DH5  
 Test Date: 2022-02-25  
 Note:

Index 66

RadiMation

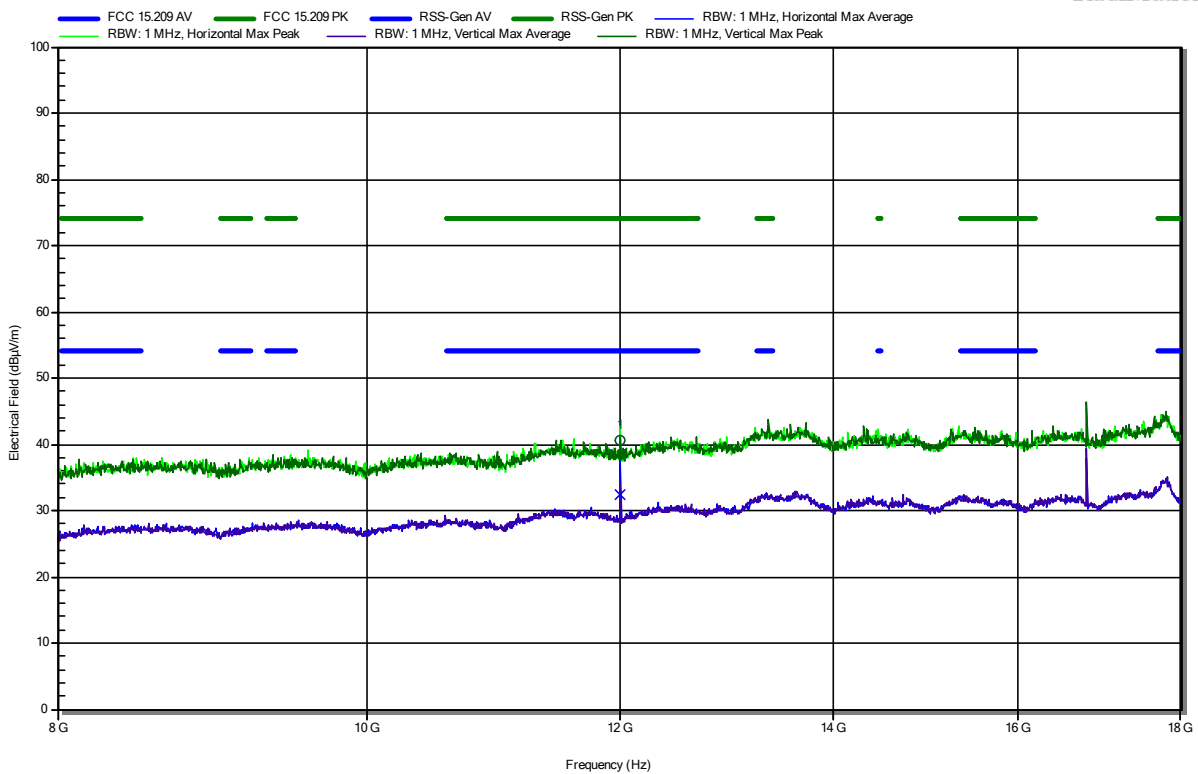

Frequency	Peak	Peak Limit	Peak Difference	Peak Status	Polarization
12.01 GHz	40.6 dBµV/m	74 dBµV/m	-33.4 dB	Pass	Horizontal
Frequency	Average	Average Limit	Average Difference	Average Status	Polarization
12.01 GHz	32.37 dBµV/m	54 dBµV/m	-21.63 dB	Pass	Horizontal

Test Report No.: G0M-2112-1231-TFC247BT-V02

Eurofins Product Service GmbH  
 Storkower Str. 38c, D-15526 Reichenwalde, Germany

### Radiated Spurious Emissions according to FCC 15.247

Project Number: G0M-2112-1231  
 Applicant: eResearchTechnology GmbH  
 Model Description: Spirometer System  
 Model: SpiroSphere  
 Test Sample ID: 38262  
 Test Site: Eurofins Product Service GmbH  
 Operator: R. Jaafar  
 Measurement software: RadiMation, version 2020.1.8  
 Test Conditions: Tnom: 24 °Celsius, Vnom:  
 Antenna: Amplifier Research AT4560  
 Measurement distance: 3 m  
 Mode: Tx; BT classic, Ch 0, GFSK, 1-DH5  
 Test Date: 2022-02-28  
 Note:

Index 70

**RadiMation**

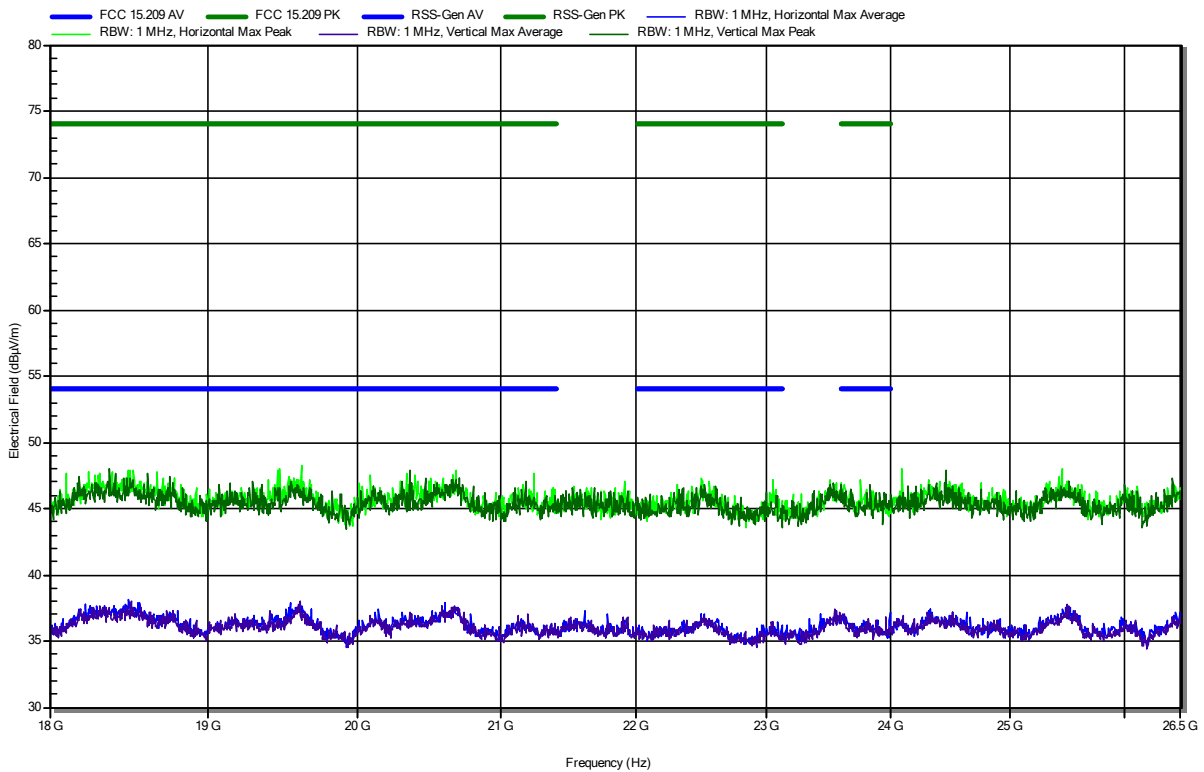

=== END OF TEST REPORT ===