

# FCC TEST REPORT(GSM)

for

**AcrossTechs, LLC**

GSM bar phone

Model Number: 201401,C101A

FCC ID: 2AAUA201401

Prepared for : AcrossTechs, LLC  
Address : 13601 Preston Road, Suite W615, Dallas, TX 75240 USA

Prepared by : Keyway Testing Technology Co., Ltd.  
Address : Baishun Industrial Zone, Zhangmutou Town,  
Dongguan, Guangdong, China



Tel: 86-769-8718 2258  
Fax: 86-769-8718 1058

Report No. : 14KWE05143502F  
Date of Test : May 16~25, 2014  
Date of Report : May 25, 2014

## TABLE OF CONTENTS

Test Report Declaration	Page
1. TEST SUMMARY .....	4
2. GENERAL PRODUCT INFORMATION .....	5
2.1. Product Function.....	5
2.2. Description of Device (EUT) .....	5
2.3. Difference between Model Numbers.....	5
2.4. Test Supporting System.....	5
2.5. Independent Operation Modes .....	6
2.6. Test Facilities .....	6
2.7. List of Test and Measurement Instruments.....	7
3. TEST SET-UP AND OPERATION MODES .....	8
3.1. Principle of Configuration Selection .....	8
3.2. Block Diagram of Test Set-up .....	8
3.3. Test Operation Mode and Test Software .....	8
3.4. Special Accessories and Auxiliary Equipment .....	8
3.5. Countermeasures to Achieve EMC Compliance.....	8
4. EMISSION TEST RESULTS .....	9
4.1. Conducted Emission at the Mains Terminals Test.....	9
4.2. Conducted RF Output Power.....	11
4.3. 99% & -26 dB Occupied Bandwidth.....	12
4.4. Frequency Stability .....	15
4.5. Conducted Out of Band Emissions .....	17
4.6. Conducted Out of Band Emissions .....	24
4.7. Transmitter Radiated Power (EIRP/ERP).....	26
4.8. Radiated Out of Band Emissions .....	30
5. PHOTOGRAPHS OF TEST SET-UP .....	34
6. PHOTOGRAPHS OF THE EUT .....	34

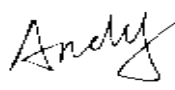
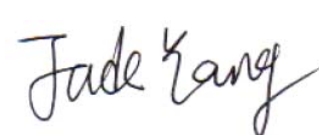
## Keyway Testing Technology Co., Ltd.

<b>Applicant:</b>	AcrossTechs, LLC		
<b>Address:</b>	13601 Preston Road, Suite W615, Dallas, TX 75240 USA		
<b>Manufacturer:</b>	Honsung International Industry Ltd.		
<b>Address:</b>	2FL, East Wing, WanYuan Building, Shangbu Industry Park, Hongli Road, Futian District, Shenzhen, PRC		
<b>E.U.T:</b>	GSM bar phone		
<b>Model Number:</b>	201401,C101A		
<b>Trade Name:</b>	AcrossTechs	<b>Serial No.:</b>	-----
<b>Date of Receipt:</b>	May 15, 2014	<b>Date of Test:</b>	May 16~25, 2014
<b>Test Specification:</b>	FCC CFR Title 47 Part 2: 2013 FCC CFR Title 47 Part22 Subpart H: 2013 FCC CFR Title 47 Part24 Subpart E: 2013		
<b>Test Result:</b>	The equipment under test was found to be compliance with the requirements of the standards applied.		
		<b>Issue Date: May 25, 2014</b>	
Tested by:	Reviewed by:	Approved by:	
			
Andy Gao / Engineer	Jade Yang/ Supervisor	Chris Du / Manager	
<b>Other Aspects:</b>	None.		
<i>Abbreviations: OK/P=passed    fail/F=failed    n.a/N=not applicable    E.U.T=equipment under tested</i>			
<i>This test report is based on a single evaluation of one sample of above mentioned products. It is not permitted to be duplicated in extracts without written approval of Keyway Testing Technology Co., Ltd.</i>			

## 1.TEST SUMMARY

Test Items	Test Requirement	Result
Conducted Emission at the Mains Terminals	15.207	PASS
RF Exposure (SAR)	Part 1.1307 Part 2.1093	Passed* (Please refer to SAR Report)
Conducted RF Output Power	2.1046	PASS
99% & -26 dB Occupied Bandwidth	2.1049, 22.917 24.238,	PASS
Frequency Stability	2.1055, 22.355 24.235,	PASS
Conducted Out of Band Emissions	2.1051,2.1057 22.917, 24.238	PASS
Band Edge	2.1051,2.1057 22.917, 24.238	PASS
Transmitter Radiated Power (EIPR/ERP)	22.913, 24.232	PASS
Radiated Out of Band Emissions	2.1053,2.1057 22.917, 24.238	PASS

## 2.GENERAL PRODUCT INFORMATION

### 2.1. Product Function

Refer to Technical Construction Form and User Manual.

### 2.2. Description of Device (EUT)

Product Name:	GSM bar phone
Model No.:	201401,C101A
Operation Frequency:	Bluetooth:2402~2480MHz GSM 850MHz: Tx: 824.20 - 848.80MHz (at intervals of 200kHz); Rx: 869.20 - 893.80MHz (at intervals of 200kHz) GSM 1900MHz: Tx: 1850.20 - 1909.80MHz (at intervals of 200kHz); Rx: 1930.20 - 1989.80MHz (at intervals of 200kHz)
Channel numbers:	Bluetooth:79 Channels
Channel separation:	Bluetooth:1M
Modulation technology:	Bluetooth: FHSS(GFSK 1Mbps) GSM Mode with GMSK Modulation
Antenna Type:	Integral Antenna
Antenna gain:	1dBi (BT),1.2dBi (GSM)
Power supply:	DC 5.2V from adapter Rechargeable lithium-ion battery 3.7V

### 2.3. Difference between Model Numbers

The product different for model number and outlook color.

### 2.4. Test Supporting System

#### 2.4.1. AC Adapter:

Provide: Honsung International Industry Ltd.  
M/N: HS-1000  
I/P: AC 100~240V 0.2A  
O/P: DC 5.2V 0.5A  
FCC Approve: FCC VOC

## 2.5. Independent Operation Modes

During all testing, EUT is in link mode with base station emulator at maximum power level. The spurious emission measurements were carried out in semi-anechoic chamber with 3-meter test range, and EUT is rotated on three test planes to find out the worst emission.

Test modes		
Band	Radiated	Conducted
<b>GSM 850</b>	■ GSM link	■ GSM link
<b>PCS 1900</b>	■ GSM link	■ GSM link

Note: The maximum power levels are GSM mode for GMSK link,

The conducted average power tables are as follows:

Conducted Average Power (dBm)						
Band	GSM850			PCS1900		
Channel	128	190	251	512	661	810
Frequency	824.20	836.60	848.80	1850.20	1880.00	1909.80
GSM (SIM1)	32.31	32.28	32.25	30.45	30.31	30.37
GSM (SIM2)	32.13	32.03	32.14	30.21	30.16	30.19

Note: The worst mode was in SIM1, all test data in SIM1 mode in this report..

## 2.6. Test Facilities

Lab Qualifications :   Certificated by Industry Canada  
 Registration No.: 9868A  
 Date of registration: December 8, 2011

Certificated by FCC, USA  
 Registration No.: 370994  
 Date of registration: February 21, 2012

Certificated by CNAS China  
 Registration No.: CNAS L5783  
 Date of registration: August 8, 2012

## 2.7. List of Test and Measurement Instruments

### 2.7.1. For conducted emission at the mains terminals test

Equipment	Manufacturer	Model No.	Serial No.	Last Cal.	Next Cal.
EMI Test Receiver	Rohde&Schwarz	ESCI	101156	Apr. 27,14	Apr. 27,15
Artificial Mains Network	Rohde&Schwarz	ENV216	101315	Apr. 27,14	Apr. 27,15
Artificial Mains Network (AUX)	Rohde&Schwarz	ENV216	101314	Apr. 27,14	Apr. 27,15
RF Cable	FUJIKURA	3D-2W	944 Cable	Apr. 27,14	Apr. 27,15

### 2.7.2. For radiated emission test

Equipment	Manufacturer	Model No.	Serial No.	Last Cal.	Next Cal.
EMI Test Receiver	Rohde&Schwarz	ESCI	101156	Apr. 27,14	Apr. 27,15
System Simulator	Agilent	E5515C	GB43130245	Apr. 30,14	Apr. 30,15
Power Splitter	Weinschel	1506A	NW425	Apr. 30,14	Apr. 30,15
Bilog Antenna	ETS-LINDGREEN	3142D	135452	Apr. 27,14	Apr. 27,15
Loop antenna	teseq	HLA6120	22032	Apr. 30,14	Apr. 30,15
Spectrum Analyzer	Agilent	E4411B	MY4511304	Apr. 27,14	Apr. 27,15
3m Semi-anechoic Chamber	ETS-LINDGREEN	966	KW01	Apr. 27,14	Apr. 27,15
Signal Amplifier	SONOMA	310	187016	Apr. 27,14	Apr. 27,15
Signal Amplifier	Agilent	8449B	3008A00251	Apr. 27,14	Apr. 27,15
RF Cable	IMRO	IMRO-400	966 Cable 1#	N/A	N/A
MULTI-DEVICE Controller	ETS-LINDGREEN	2090	126913	N/A	N/A
Horn Antenna	DAZE	ZN30701	11003	Apr. 27,14	Apr. 27,15
Horn Antenna	SCHWARZBECK	BBHA9170	9170-068	Apr. 27,14	Apr. 27,15
Spectrum Analyzer	Agilent	8593E	3911A04271	Apr. 27,14	Apr. 27,15
Spectrum Analyzer	Agilent	E4408B	MY44211125	Apr. 30,14	Apr. 30,15
Signal Amplifier	DAZE	ZN3380C	11001	Apr. 27,14	Apr. 27,15
High Pass filter	Micro	HPM50111	324216	Apr. 30,14	Apr. 30,15
Filter	COM-MW	ZBSF-C836.5-25-X	KW032	Apr. 30,14	Apr. 30,15
Filter	COM-MW	ZBSF-C1747.5-75-X2	KW035	Apr. 30,14	Apr. 30,15
Filter	COM-MW	ZBSF-C1880-60-X2	KW037	Apr. 30,14	Apr. 30,15
DC Power Supply	LongWei	PS-305D	010964729	Apr. 27,14	Apr. 27,15
Constant temperature and humidity box	GF	GTH-800-40-1P	MAA9906-005	Apr. 27,14	Apr. 27,15
Universal radio communication tester	Rohde&Schwarz	CMU200	3215420	Apr. 27,14	Apr. 27,15
Splitter	Agilent	11636B	0025164	Apr. 27,14	Apr. 27,15

### 3. TEST SET-UP AND OPERATION MODES

#### 3.1. Principle of Configuration Selection

**Emission:** The equipment under test (EUT) was configured to measure its highest possible radiation level. The test modes were adapted accordingly in reference to the Operating Instructions.

#### 3.2. Block Diagram of Test Set-up

System Diagram of Connections between EUT and Simulators

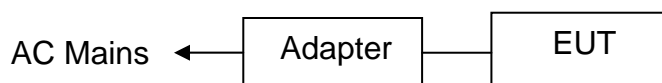

(EUT: GSM bar phone)

#### 3.3. Test Operation Mode and Test Software

None.

#### 3.4. Special Accessories and Auxiliary Equipment

None.

#### 3.5. Countermeasures to Achieve EMC Compliance

None.



## 4. EMISSION TEST RESULTS

### 4.1. Conducted Emission at the Mains Terminals Test

#### 4.1.1. Limit 15.207 limits

FREQUENCY OF EMISSION (MHz)	CONDUCTED LIMIT (dBµV)	
	Quasi-peak	Average
0.15-0.5	66 to 56	56 to 46
0.5-5	56	46
5-30	60	50

#### 4.1.2. Test Setup

The EUT was put on a wooden table which was 0.8 m high above the ground and connected to the AC mains through the Artificial Mains Network (AMN). Where the mains cable supplied by the manufacture was longer than 0.8 m, the excess was folded back and forth parallel to the cable at the centre so as to form a bundle no longer than 0.4 m.

The EUT was kept 0.4 m from any other earthed conducting surface. Both sides of AC line were checked to find out the maximum conducted emission levels according to the test procedure during the conducted emission test.

The frequency range from 150 kHz to 30 MHz was investigated.

The bandwidth of the test receiver was set at 9 kHz.

Pretest for all mode, The test data of the worst case condition(s) was reported on the following page.

Measurement Uncertainty: ±2.6 dB.

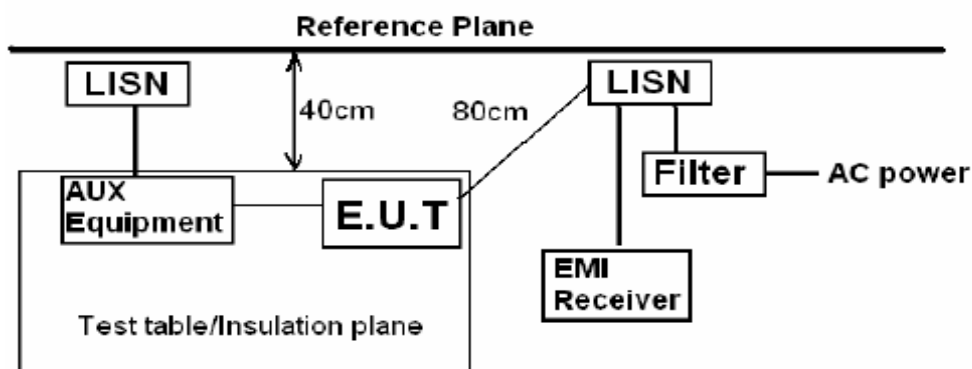

*Remark:*  
 E.U.T: Equipment Under Test  
 LISN: Line Impedance Stabilization Network  
 Test table height=0.8m

#### 4.1.3. Test Mode

Refer to section 2.5 for details

Line

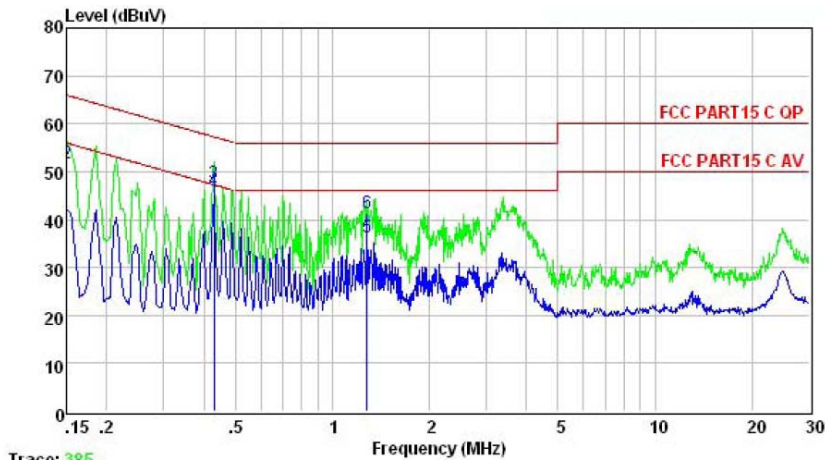

	Freq	Level	Limit	Over	Remark
	MHz	dBuV	dBuV	dB	
1	0.150	42.12	56.00	-13.88	Average
2	0.150	51.70	66.00	-14.30	QP
3	0.431	47.60	57.24	-9.64	QP
4	0.431	46.03	47.24	-1.21	Average
5	1.282	36.43	46.00	-9.57	Average
6	1.282	41.30	56.00	-14.70	QP

Neutral

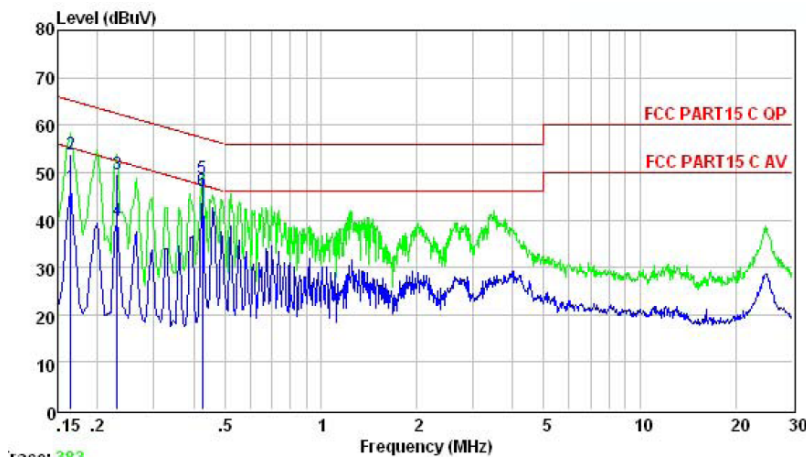

	Freq	Level	Limit	Over	Remark
	MHz	dBuV	dBuV	dB	
1	0.165	46.99	55.21	-8.22	Average
2	0.165	53.70	65.21	-11.51	QP
3	0.230	49.60	62.45	-12.85	QP
4	0.230	39.78	52.44	-12.66	Average
5	0.426	48.80	57.33	-8.53	QP
6	0.426	46.01	47.33	-1.32	Average

## 4.2. Conducted RF Output Power

### 4.2.1. Limit

According to FCC section 2.1046(a) , FCC part22.913(a) and FCC part24.232(b) ,for transmitters other than single sideband, independent sideband and controlled carrier radiotelephone, power output shall be measured at the RF output terminals when the transmitter is adjusted in accordance with the tune-up procedure to give the values of current and voltage on the circuit elements specified in FCC section 2.1033(c)(8).

### 4.2.2. Test Setup

The EUT, which is powered by the adapter, is coupled to the Spectrum Analyzer (SA) and the System Simulator (SS) with Attenuators through the Power Splitter; the RF load attached to the EUT antenna terminal is 50Ohm; the path loss as the factor is calibrated to correct the reading. The EUT is commanded by the SS to operate at the maximum output power.

### 4.2.3. Test Result

Here the lowest, middle and highest channels are selected to perform testing to verify the conducted RF output power of the EUT.

Measurement data

EUT Mode	Channel	Frequency (MHz)	AV power (dBm)	Limit (dBm)	Result
GSM 850 (GSM link)	128	824.20	32.31	38.45	Pass
	190	836.60	32.28		
	251	848.80	32.25		
PCS 1900 (GSM link)	512	1850.20	30.45	33.01	Pass
	661	1880.00	30.31		
	810	1909.80	30.37		

Note: Measurement Uncertainty:  $\pm 2.6$  dB.

### 4.3. 99% & -26 dB Occupied Bandwidth

#### 4.3.1. Limit

According to FCC section 2.1049 and FCC part22.913(a) and FCC part24.232(b), the occupied bandwidth is the frequency bandwidth such that, below its lower and above its upper frequency limits, the mean powers radiated are each equal to 0.5 percent of the total mean power radiated by a given emission.

Occupied bandwidth is also known as the 99% emission bandwidth,

#### 4.3.2. Test Setup

The EUT, which is powered by the adapter, is coupled to the Spectrum Analyzer (SA) and the System Simulator (SS) with Attenuators through the Power Splitter; the RF load attached to the EUT antenna terminal is 50Ohm; the path loss as the factor is calibrated to correct the reading. The EUT is commanded by the SS to operate at the maximum output power.

#### 4.3.3. Test Result

Measurement Data

EUT Mode	Channel	Frequency (MHz)	99% Occupy bandwidth (KHz)	-26dB bandwidth (KHz)
GSM 850 (GSM link)	128	824.20	248.397	318.910
	190	836.60	246.795	317.308
	251	848.80	246.795	315.705
PCS 1900 (GSM link)	512	1850.20	246.795	320.513
	661	1880.00	248.397	315.705
	810	1909.80	248.397	312.500

Note: Measurement Uncertainty:  $\pm 20$ Hz.

Test plot as follows:

GSM 850MHz Lowest channel

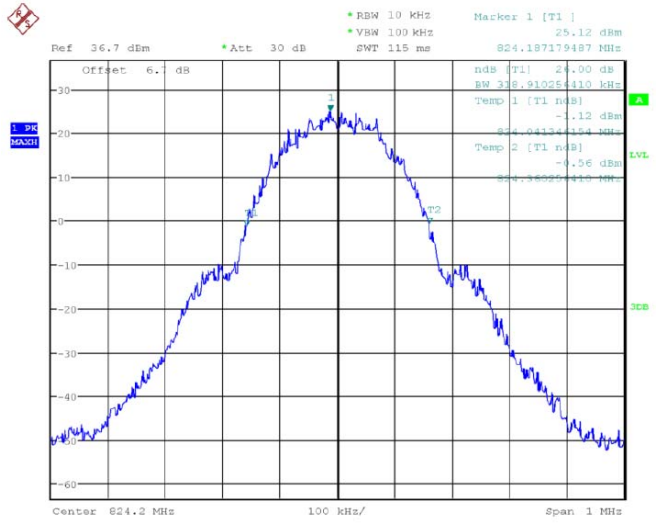
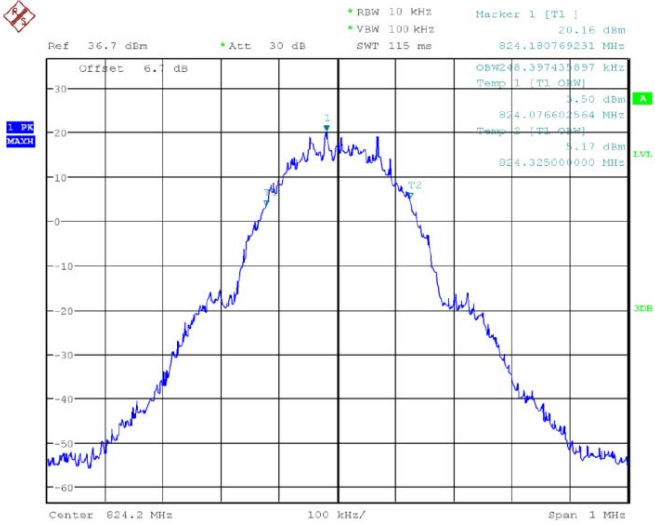

GSM 850MHz Middle channel

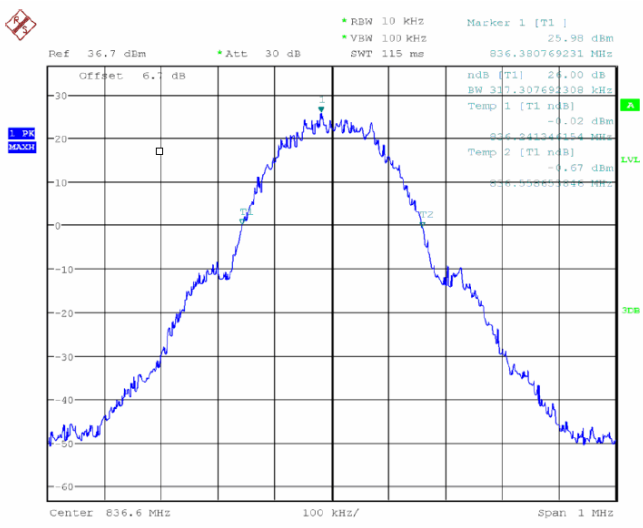
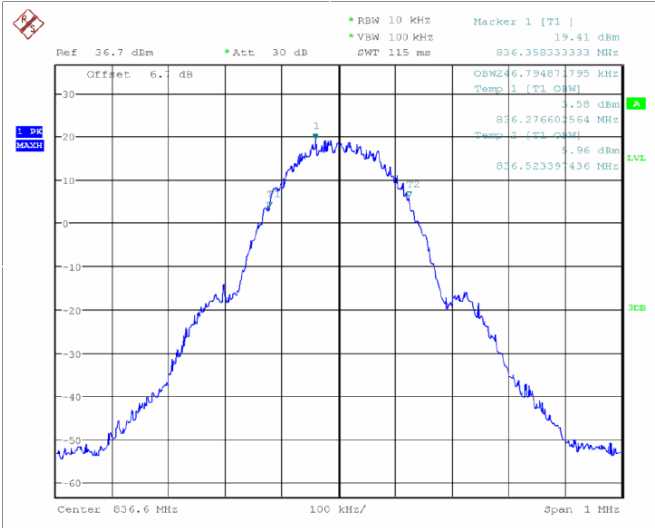

GSM 850MHz Highest channel:

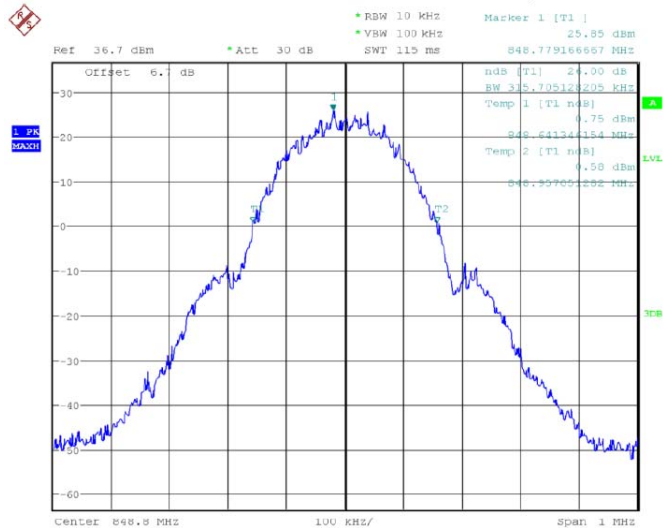
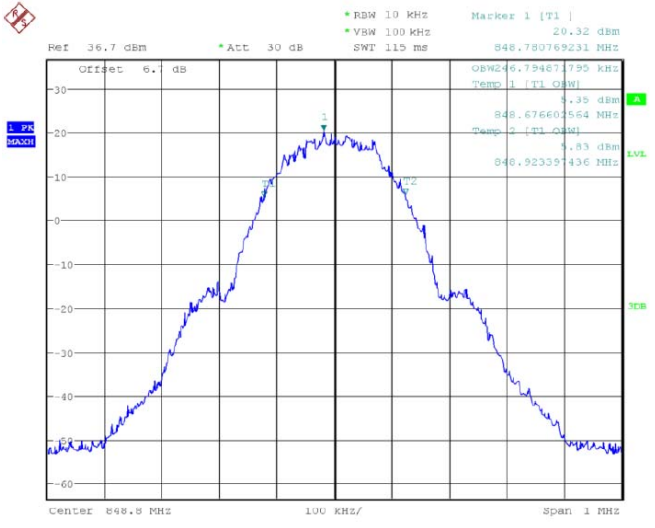

### PCS 1900 (GSM link) Lowest channel

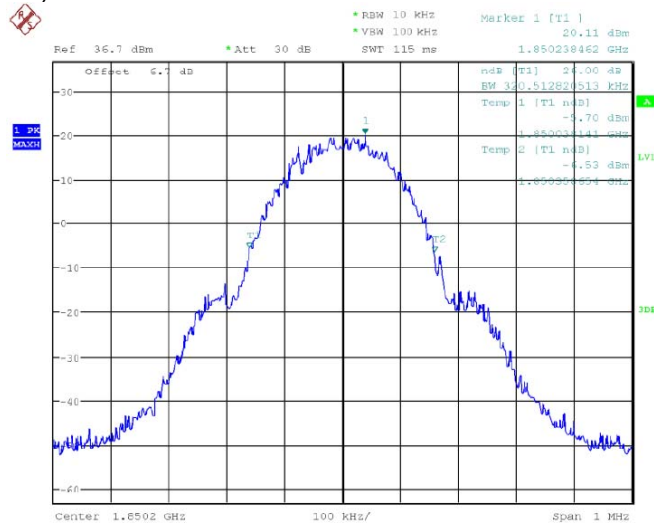
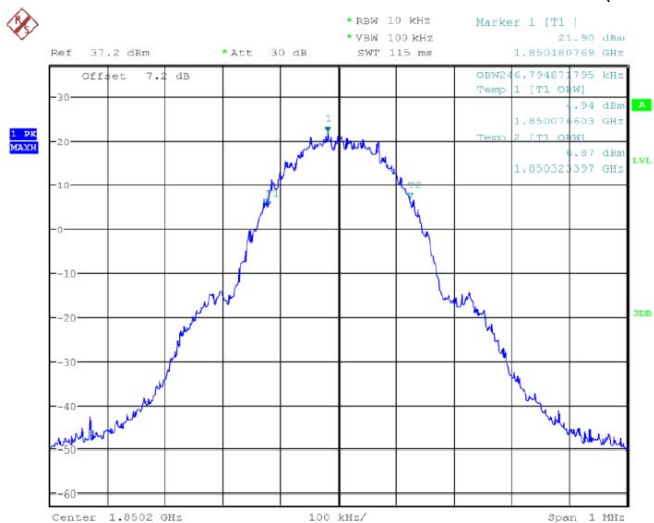

### PCS 1900 (GSM link) Middle channel

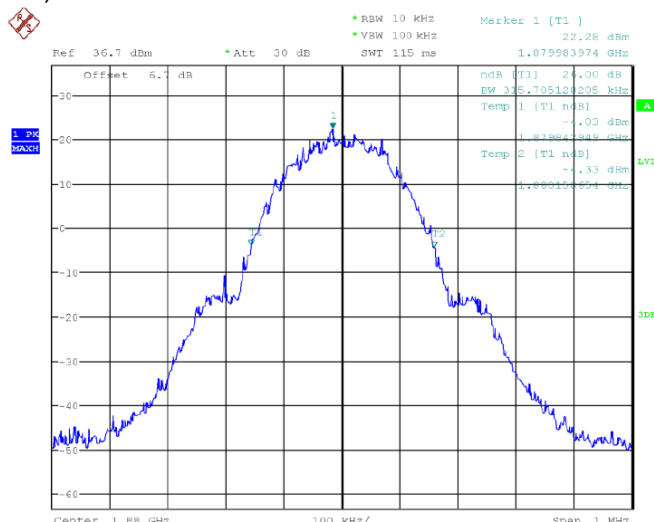
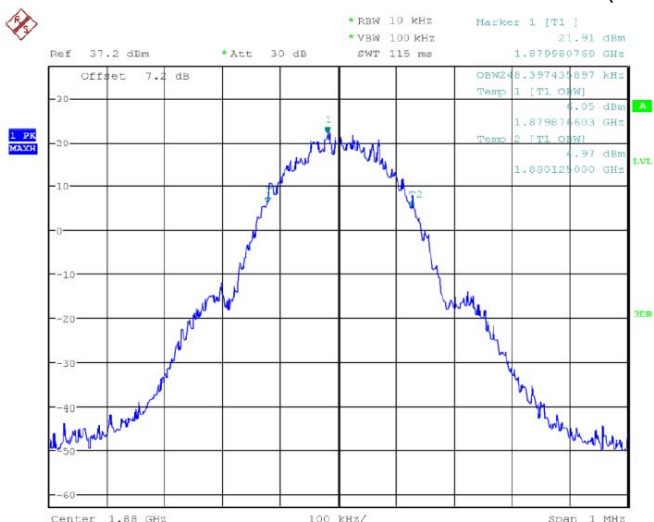

### PCS 1900 (GSM link) Highest channel

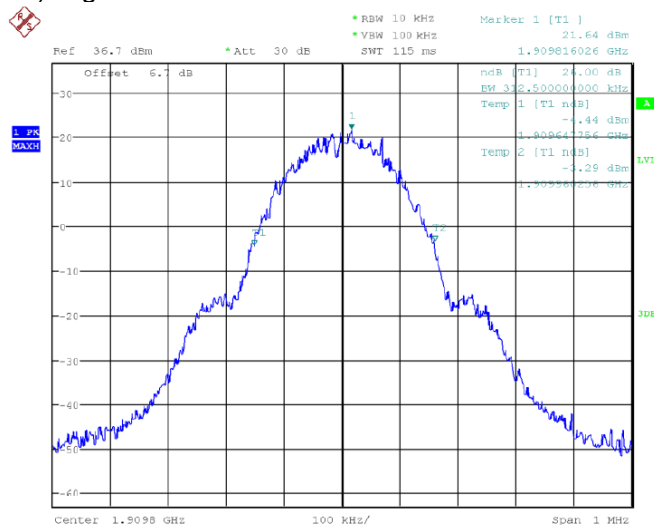
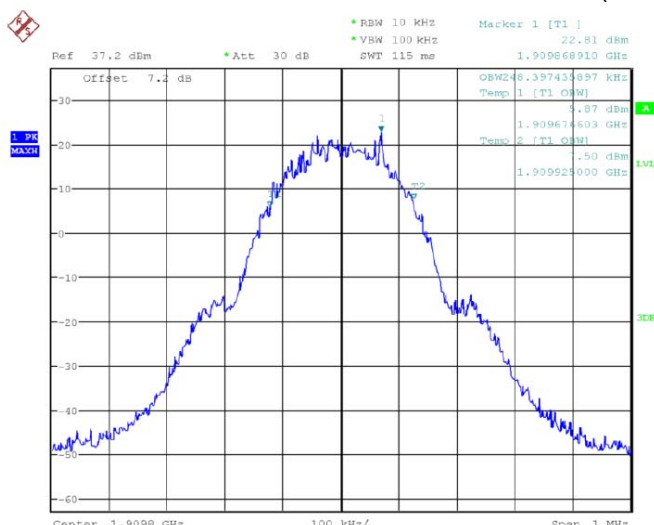

## 4.4. Frequency Stability

### 4.4.1. Limit

According to FCC section 22.355 and FCC section 24.235, the frequency stability shall be sufficient to ensure that the fundamental emission stays within the authorized frequency block. According to FCC section 2.1055, the test conditions are:

- (a) The temperature is varied from  $-30^{\circ}\text{C}$  to  $+50^{\circ}\text{C}$  at intervals of not more than  $10^{\circ}\text{C}$ .
- (b) For hand carried battery powered equipment, the primary supply voltage is reduced to the battery operating end point which shall be specified by the manufacture. The supply voltage shall be measured at the input to the cable normally provided with the equipment, or at the power supply terminals if cables are not normally provided.

### 4.4.2. Test Setup

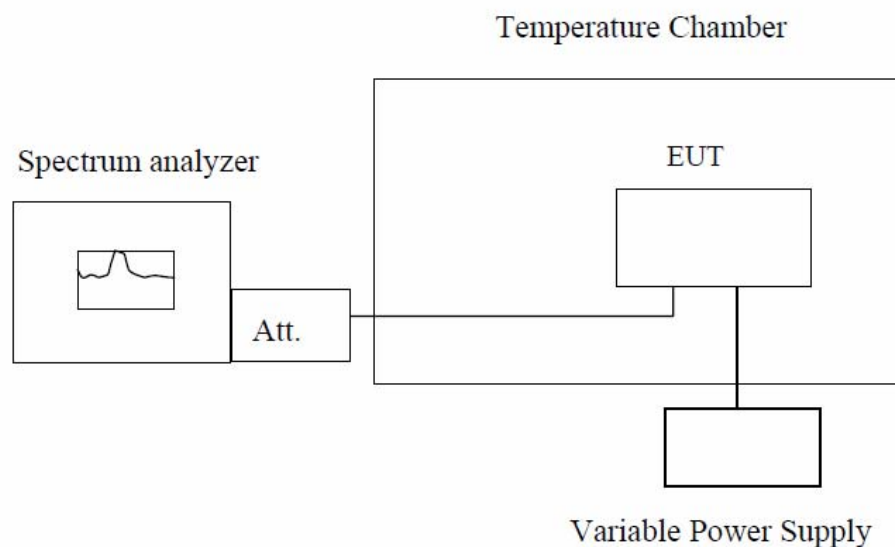

**Note :** Measurement setup for testing on Antenna connector

The EUT, which is powered by the DC Power Supply directly, is located in the Temperature Chamber.

The EUT is commanded by the System Simulator (SS) to operate at the maximum output power

### 4.4.3. Test Result

The nominal, highest and lowest extreme voltages are separately 3.7VDC, 4.25VDC and 3.4VDC which are specified by the applicant; the normal temperature here used is  $25^{\circ}\text{C}$ . The frequency deviation limit of 850MHz band is  $\pm 2.5\text{ppm}$ , and 1900MHz is  $\pm 1\text{ppm}$

Normal

Test Conditions			Frequency Deviation			Result
Band	Power(Vdc)	Temperature(°C)	Frequency Error(Hz)	ppm	Limit	
GSM850 (GSM link) Middle channel=836. 6MHz	3.7	-30	36	0.0430	±2.5	PASS
	3.7	-20	34	0.0406		
	3.7	-10	32	0.0383		
	3.7	0	31	0.0371		
	3.7	10	35	0.0418		
	3.7	20	32	0.0383		
	3.7	30	24	0.0287		
	3.7	40	35	0.0418		
	3.7	50	32	0.0383		
	4.25	25	34	0.0406		
	3.70	25	21	0.0251		
	3.40	25	33	0.0394		
PCS1900 (GSM link) Middle channel=188 0MHz	3.7	-30	65	0.0346	±1	PASS
	3.7	-20	73	0.0388		
	3.7	-10	64	0.0340		
	3.7	0	62	0.0330		
	3.7	10	54	0.0287		
	3.7	20	52	0.0277		
	3.7	30	45	0.0239		
	3.7	40	62	0.0330		
	3.7	50	53	0.0282		
	4.25	25	52	0.0277		
	3.70	25	65	0.0346		
	3.40	25	61	0.0324		

Note: Measurement Uncertainty: ±20Hz.



## 4.5. Conducted Out of Band Emissions

### 4.5.1. Limit

According to FCC section 22.917(a) and FCC section 24.238(a), the power of any emission outside of the authorized operating frequency ranges must be attenuated below the transmitting power (P) by a factor of at least  $43+10*\log(P)$ dB. This calculated to be -13dBm.

### 4.5.2. Test Setup

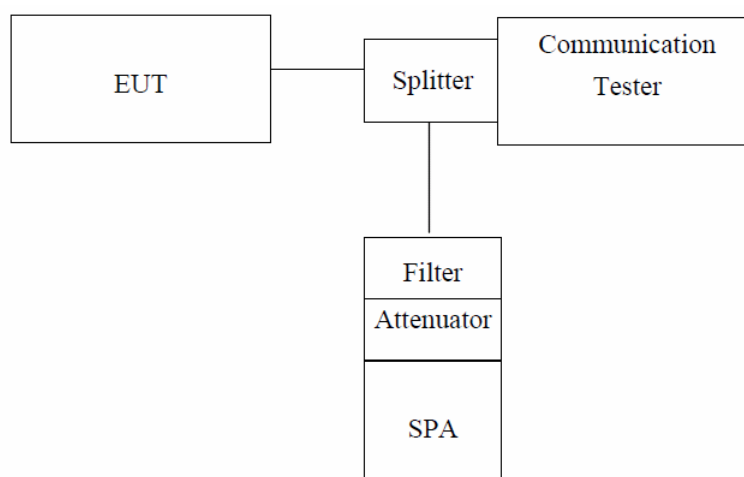

*Note: Measurement setup for testing on Antenna connector*

### 4.5.3. Measurement Procedure

The RF output of the transceiver was connected to a spectrum analyzer through appropriate attenuation. The resolution bandwidth of the spectrum analyzer was set at 1MHz, sufficient scans were taken to show the out of band Emissions if any up to 10th harmonic.

For the out of band: Set the RBW, VBW = 100KHz, Start=30MHz, Stop= 10th harmonic.

Limit = -13dBm

Note: used 5001 sweep points for each plots.

### 4.5.4. Test Result

The measurement frequency range is from 30MHz to the 10th harmonic of the fundamental frequency. The lowest, middle and highest channels are tested to verify the out of band emissions.

Test plot as follows:

### GSM 850MHz Lowest channel

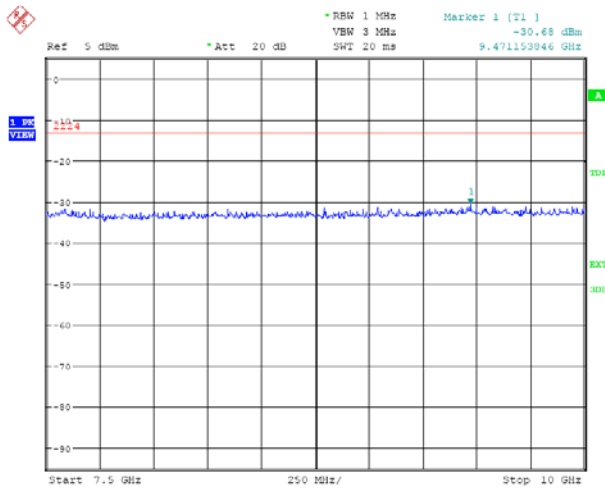
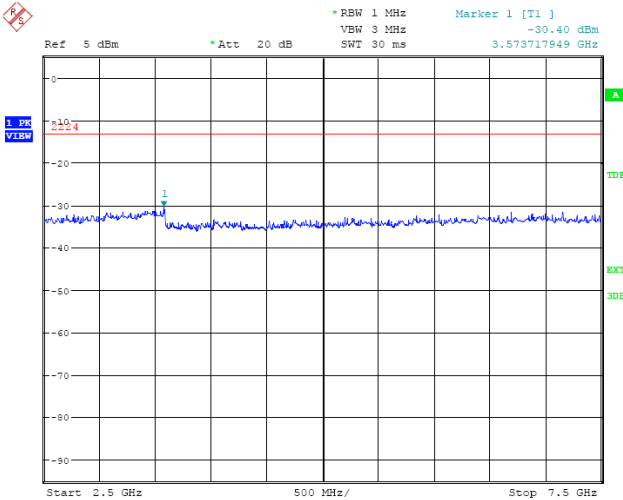
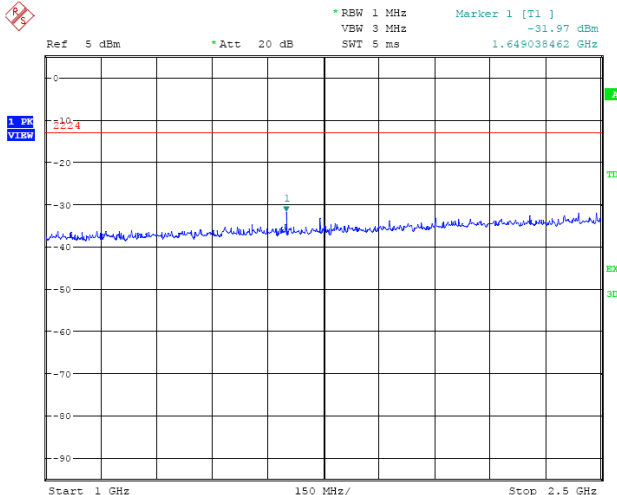
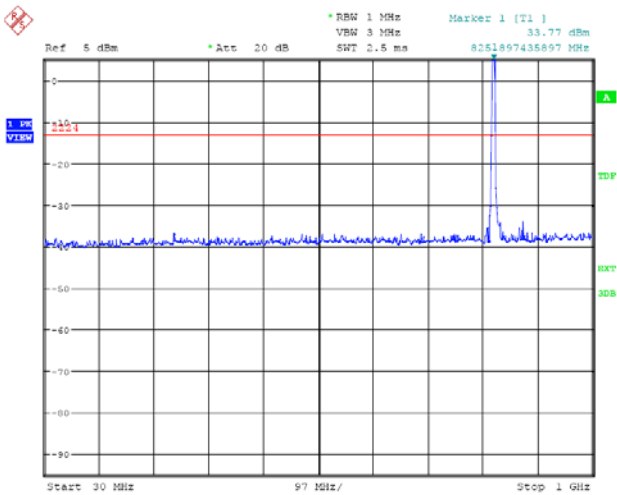

GSM 850MHz middle channel

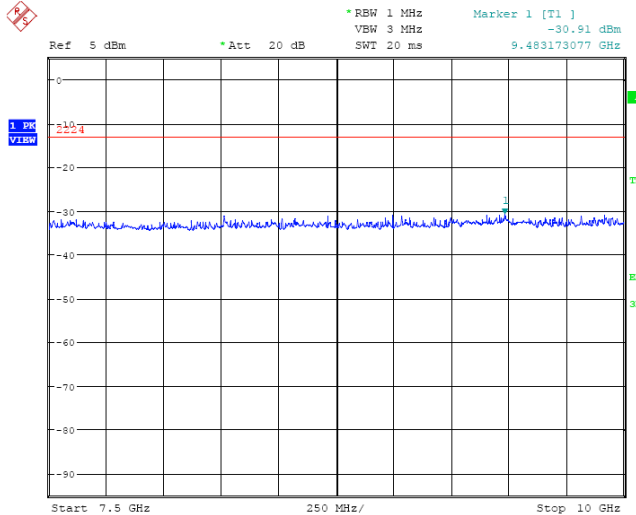
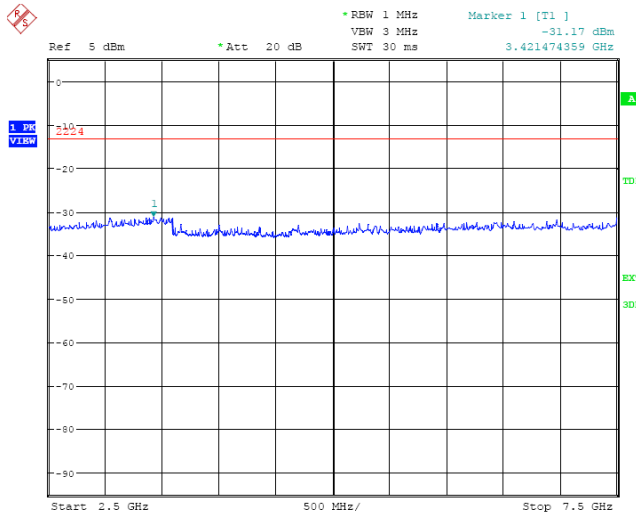
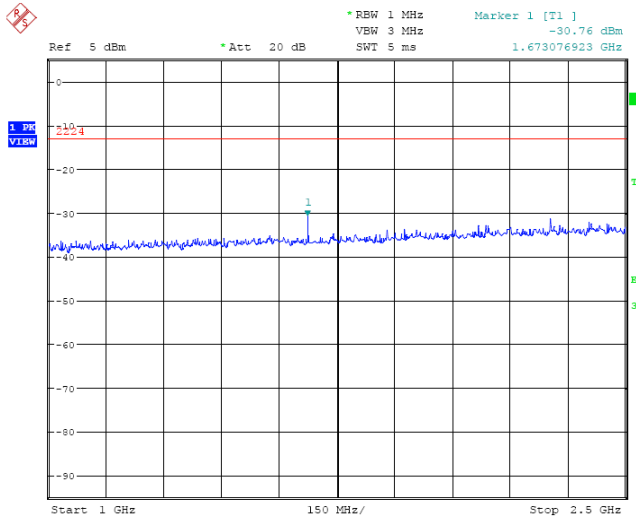
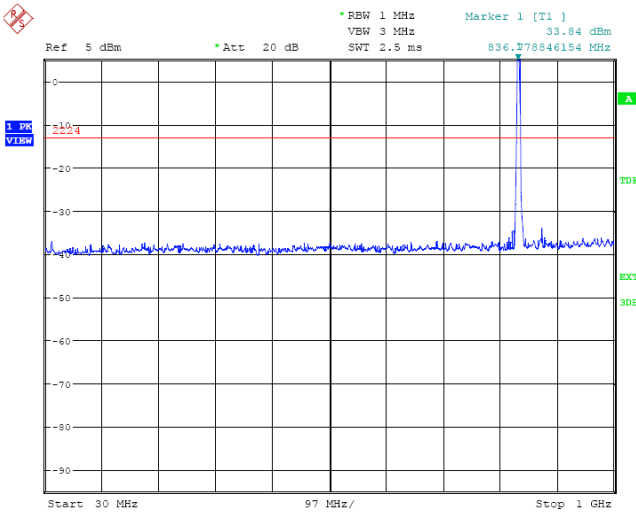

### GSM 850MHz Highest channel

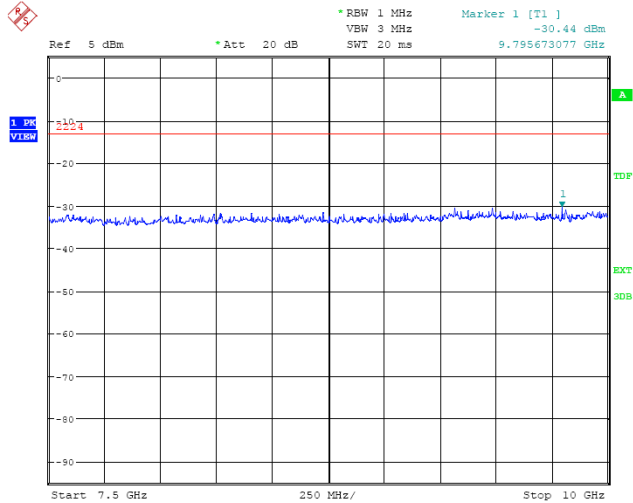
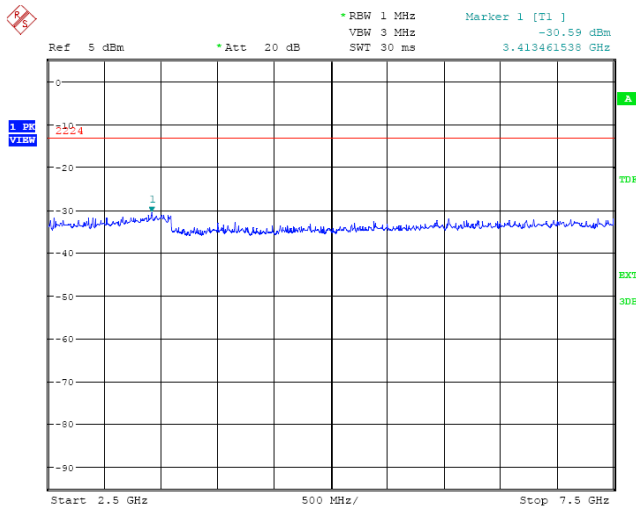
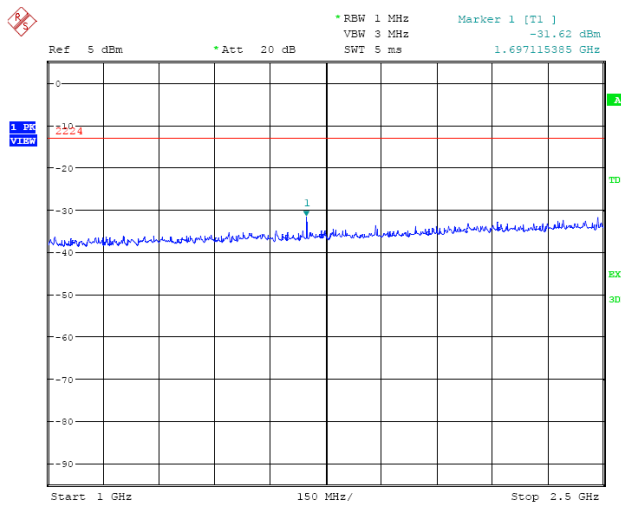
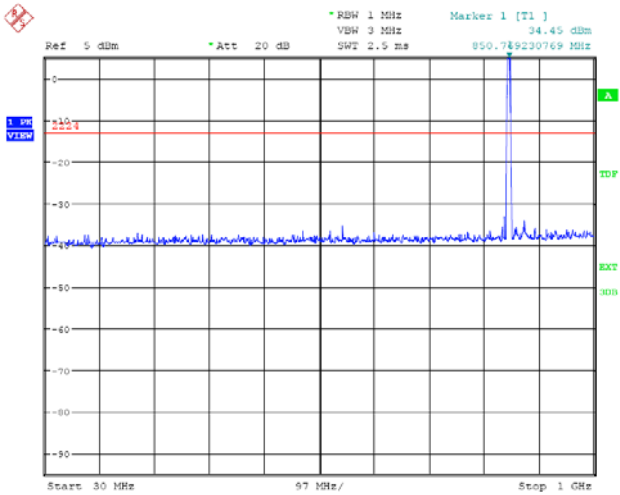

GSM 1900MHz Lowest channel

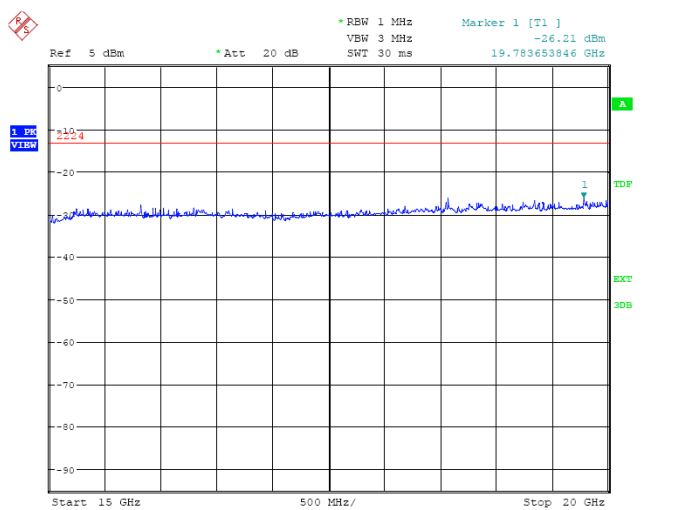
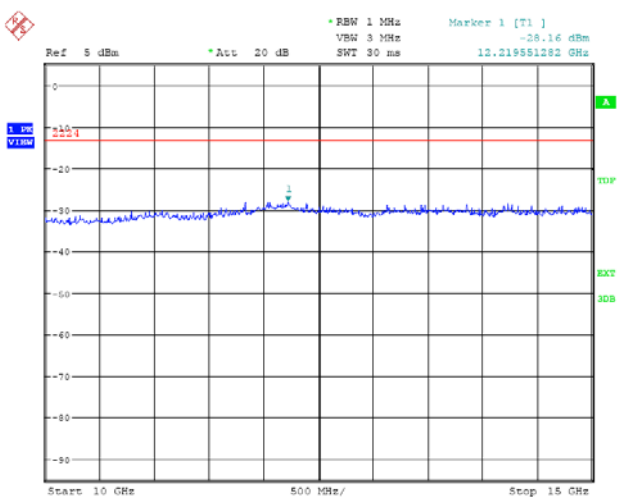
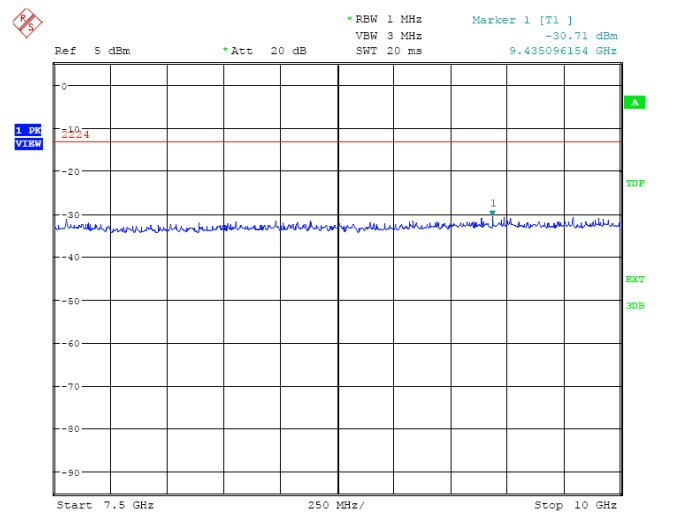
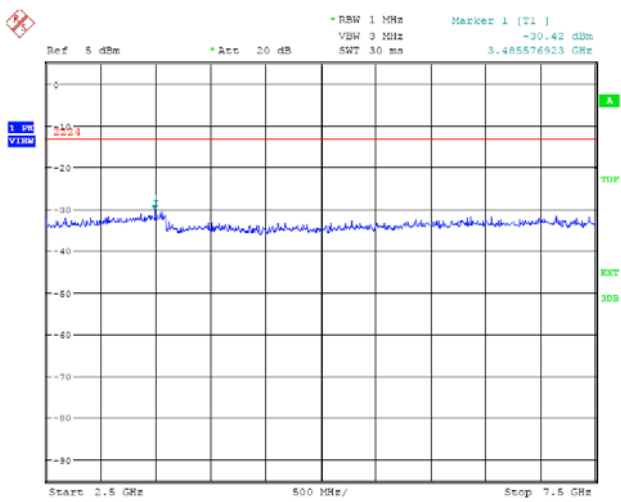
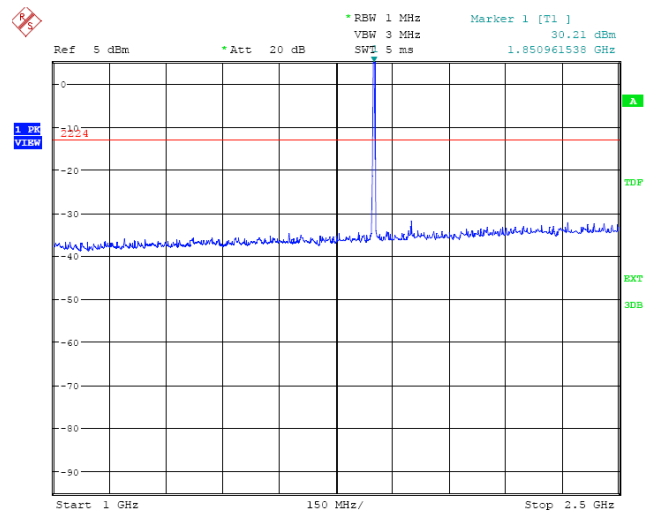
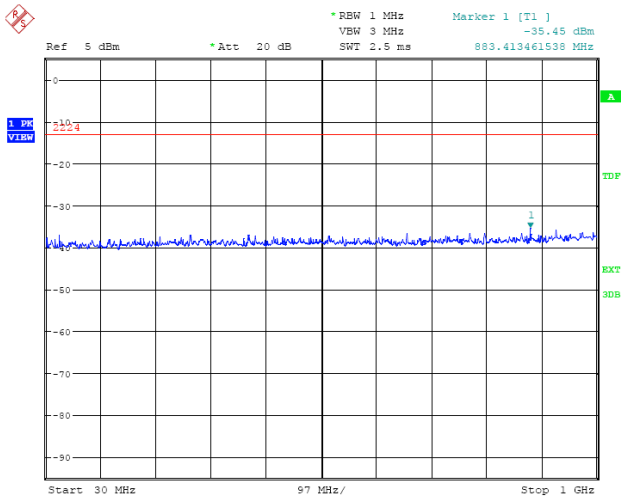

### GSM 1900MHz Middle channel

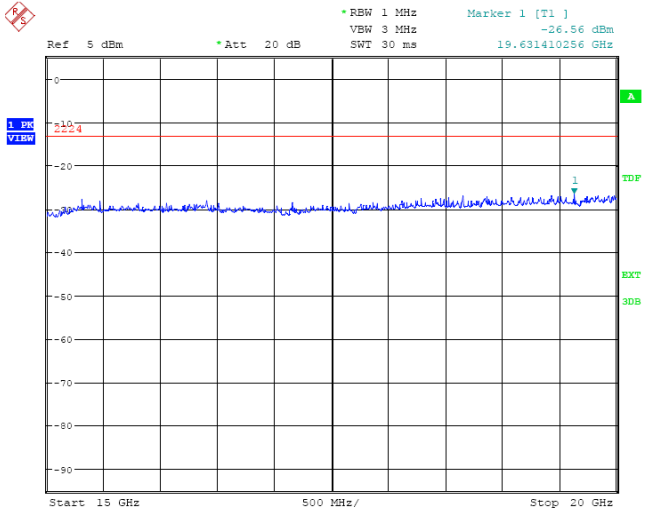
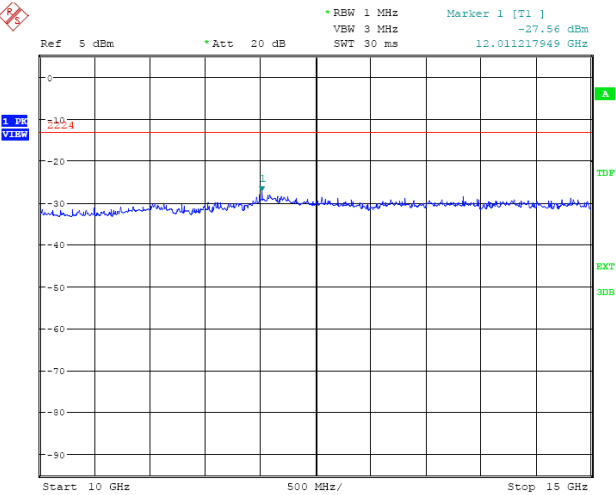
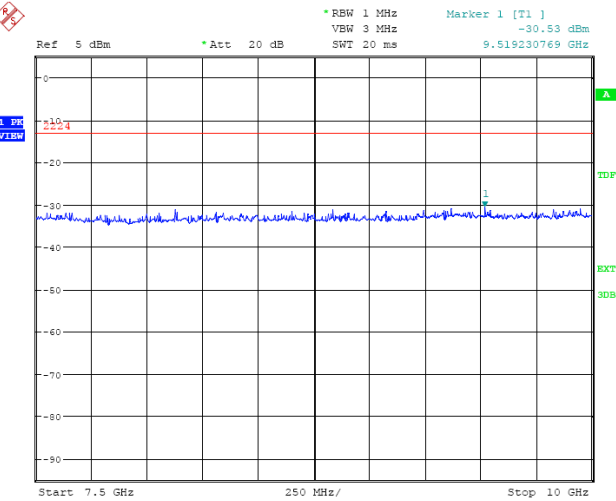
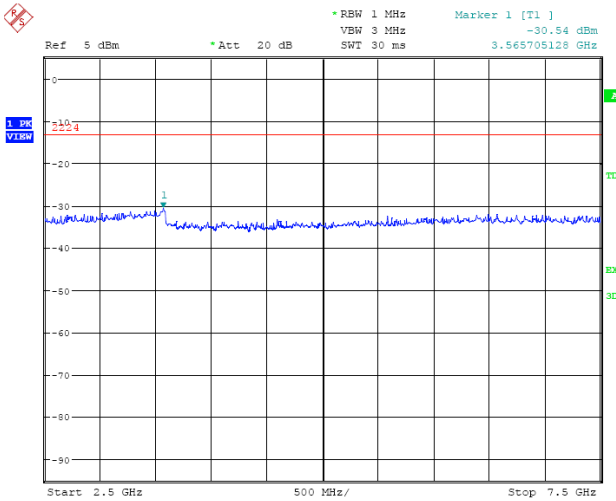
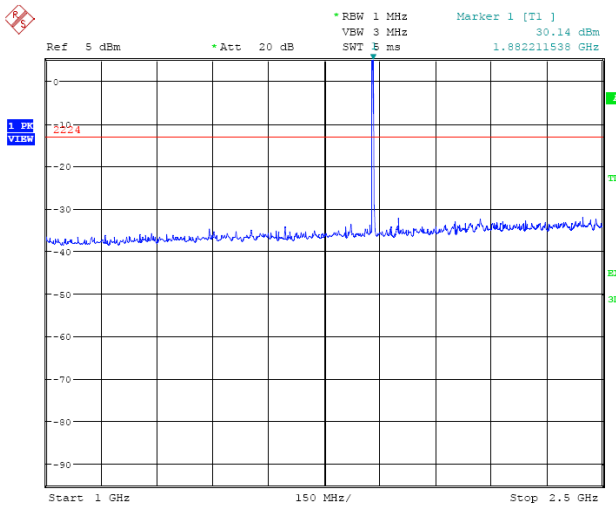
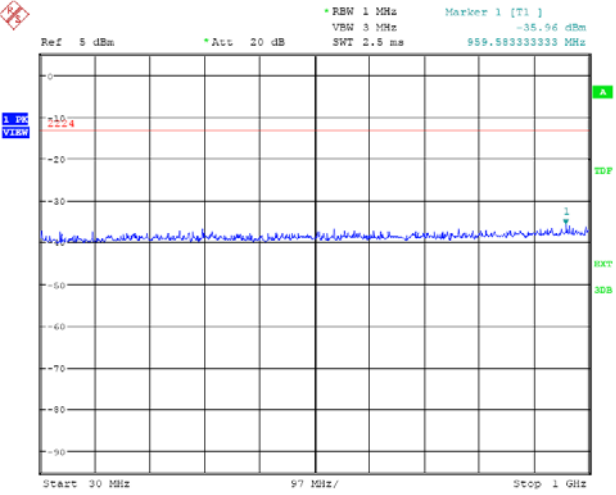

### GSM 1900MHz Highest channel

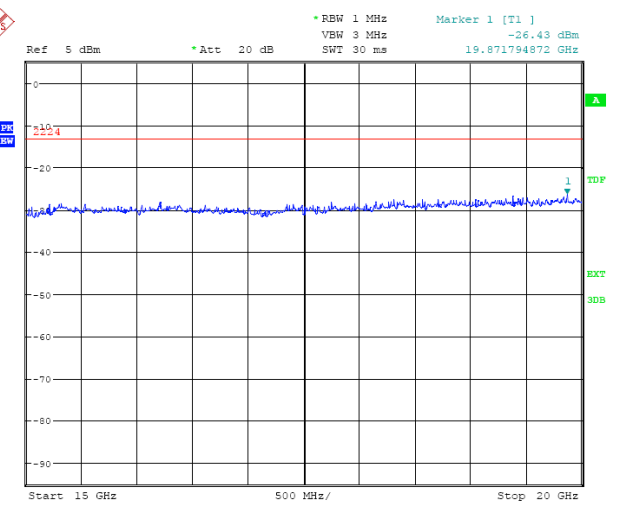
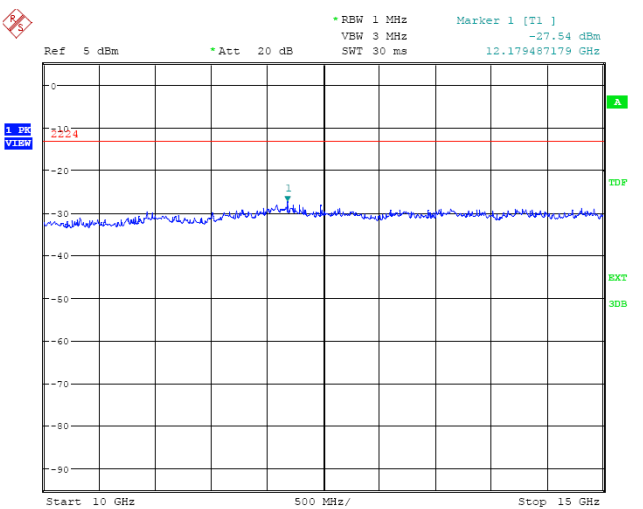
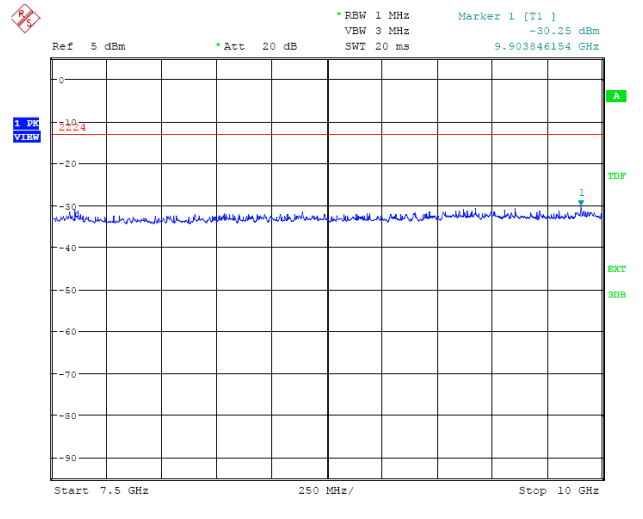
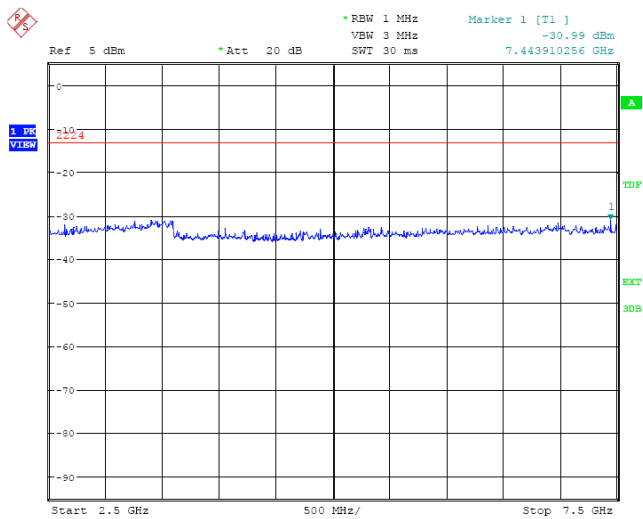
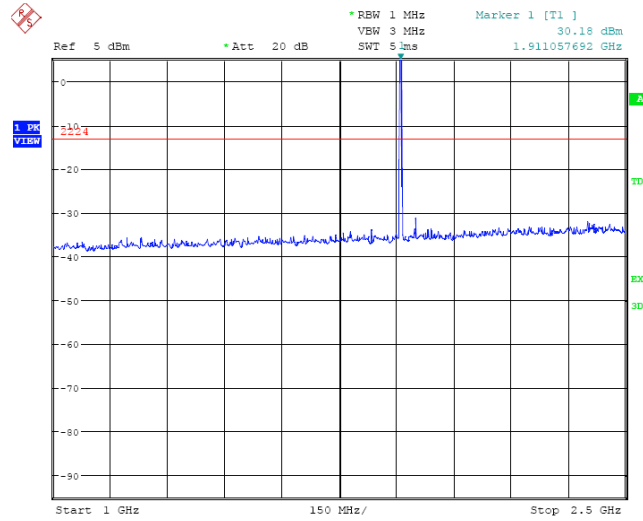
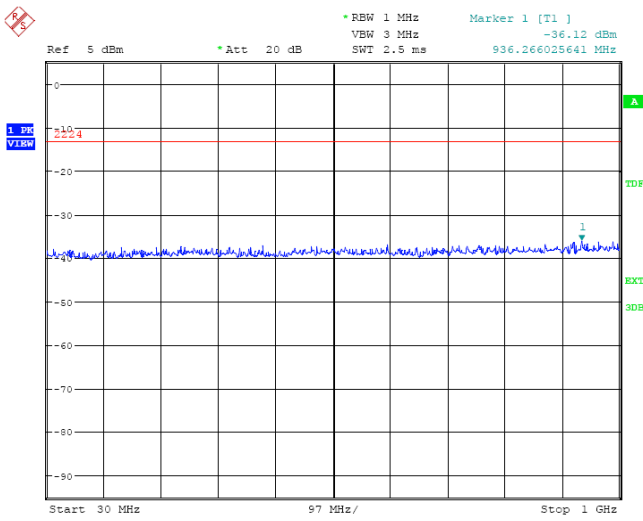

## 4.6. Conducted Out of Band Emissions

### 4.6.1. Limit

According to FCC section 22.917(b) and FCC section 24.238(b), 27.53(g)(h) in the 1MHz bands immediately outside and adjacent to the frequency block a resolution bandwidth of at least one percent of the emission bandwidth (26dB emission bandwidth) of the fundamental emission of the transmitter may be employed.

### 4.6.2. Test Setup

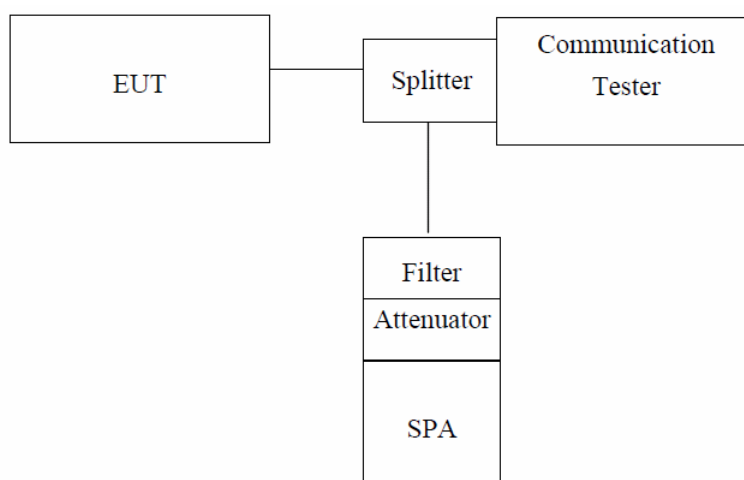

*Note: Measurement setup for testing on Antenna connector*

### 4.6.3. Measurement Procedure

The EUT, which is powered by the adapter, is coupled to the Spectrum Analyzer and the System Simulator with Attenuators through the Power Splitter; the RF load attached to the EUT antenna terminal is 50Ohm; the path loss as the factor is calibrated to correct the reading. The EUT is commanded by the System Simulator to operate at the maximum output power i.e. Power Control Level (PCL) = 5 and Power Class = 4. A call is established between the EUT and the System Simulator.

### 4.6.4. Test Result

The measurement frequency range is from 30MHz to the 10th harmonic of the fundamental frequency. The lowest, middle and highest channels are tested to verify the out of band emissions.

Test plot as follows:



GSM 850MHz Lowest channel

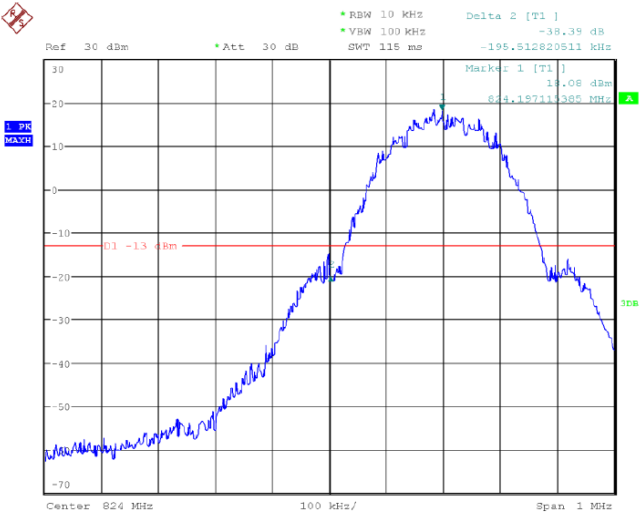

GSM 850MHz Highest channel

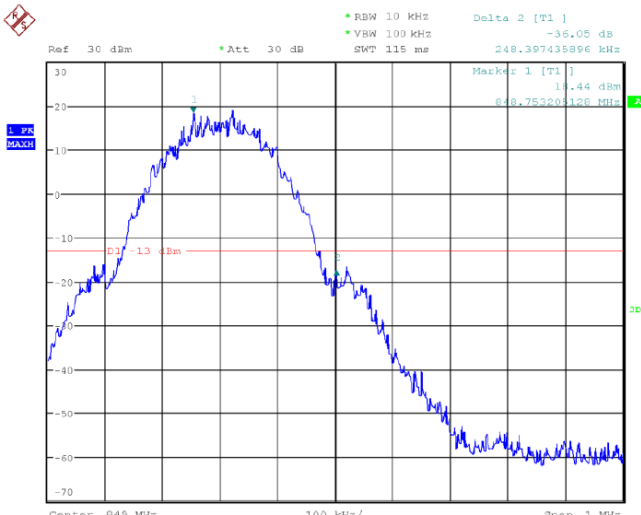

GSM 1900MHz Lowest channel

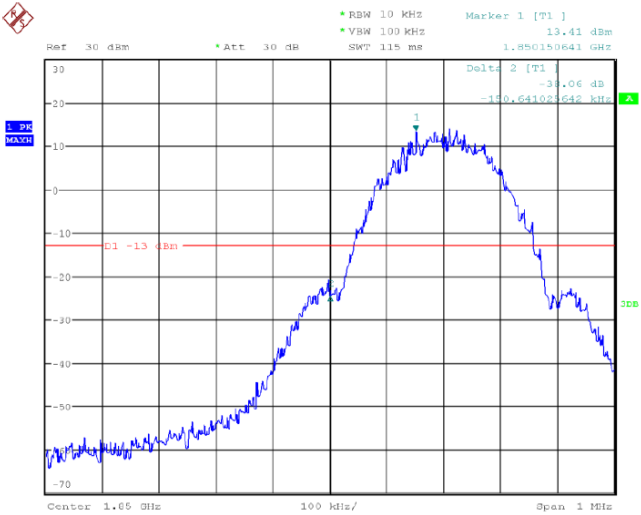

GSM 1900MHz Highest channel

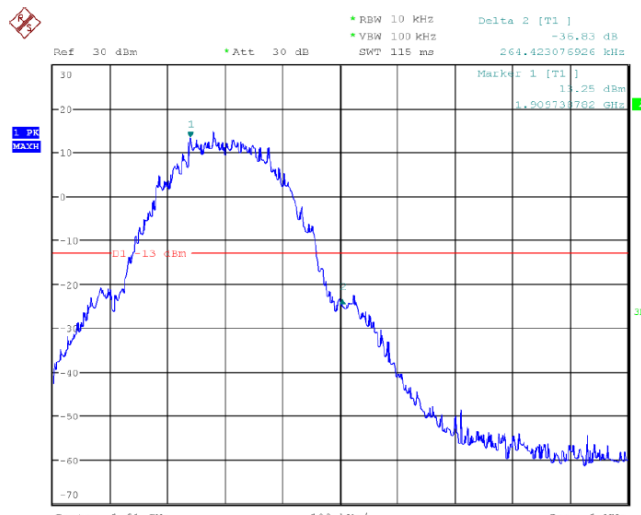

### 4.7. Transmitter Radiated Power (EIRP/ERP)

#### 4.7.1. Limit

According to FCC section 22.913, the Effective Radiated Power (ERP) of mobile transmitters and auxiliary test transmitters must not exceed 7Watts, and FCC section 24.232, the broadband PCS mobile station is limited to 2 Watts e.i.r.p. peak power.

#### 4.7.2. Test Setup

Below 1GHz

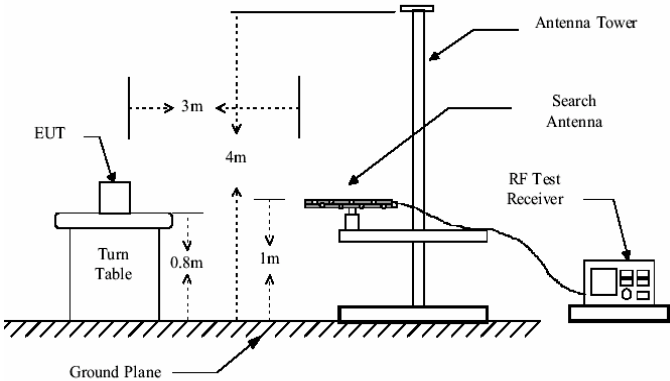

Above 1GHz

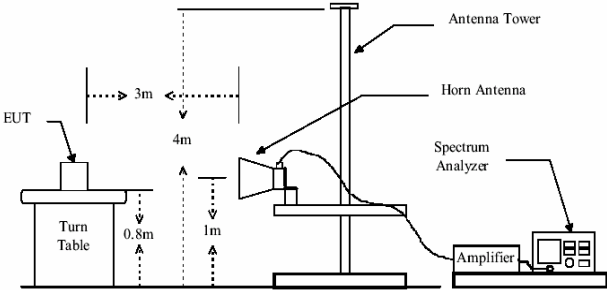

Substituted method:

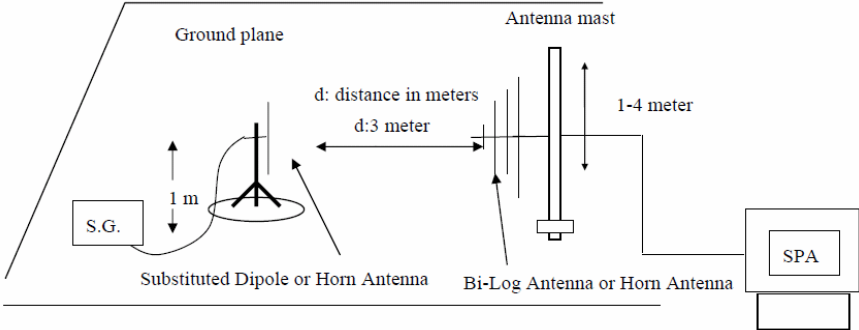

### 4.7.3. Measurement Procedure

The EUT was placed on a non-conductive turntable using a non-conductive support. The radiated emission at the fundamental frequency was measured at 3 m with a test antenna and EMI spectrum analyzer. All tests were conducted in a Full-Anechoic Chamber.

During the measurement, the EUT was in communication with the station. The highest emission was recorded with the rotation of the turntable and the lowering of the test antenna from 4m to 1m. The reading was recorded and the field strength (E in dBuV/m) was calculated.

ERP in frequency band 824.2 – 848.80.8MHz were measured using a substitution method. The EUT was replaced by a dipole antenna connected, the S.G. output was recorded and ERP was calculated as follows:

EIRP in frequency band 1850.2 – 1909.8MHz were measured using a substitution method. The EUT was replaced by a horn antenna connected, the S.G. output was recorded and EIRP was calculated as follows:

$$\text{ERP} = \text{S.G. output (dBm)} + \text{Antenna Gain (dBd)} - \text{Cable Loss (dB)}$$

$$\text{EIRP} = \text{S.G. output (dBm)} + \text{Antenna Gain (dBi)} - \text{Cable Loss (dB)}$$

Note: By final testing and verifying three axis (X, Y and Z) position of EUT transmitted status, the result recording in the report. The H means X axis, E1 means Y axis, E2 means Z axis.

### 4.7.4. Test Result

EUT mode	Channel	EUT Pol.	Antenna Pol.	ERP(dBm)	Limit (dBm)	Result
GSM850 (GSM link)	Lowest	H	V	30.89	38.45	Pass
			H	31.18		
		E1	V	27.98		
			H	28.37		
		E2	V	28.61		
			H	29.03		
	Middle	H	V	31.23	38.45	Pass
			H	30.03		
		E1	V	25.34		
			H	29.53		
		E2	V	26.29		
			H	29.03		
	Highest	H	V	<b>32.26</b>	38.45	Pass
			H	29.86		
		E1	V	25.78		
			H	28.91		
		E2	V	24.65		
			H	29.17		

EUT mode	Channel	EUT Pol.	Antenna Pol.	EIRP (dBm)	Limit (dBm)	Result
PCS1900 (GSM link)	Lowest	H	V	30.02	33.01	Pass
			H	28.12		
		E1	V	23.43		
			H	27.16		
		E2	V	23.03		
			H	24.71		
	Middle	H	V	<b>30.41</b>	33.01	Pass
			H	28.11		
		E1	V	24.81		
			H	28.73		
		E2	V	23.92		
			H	28.78		
	Highest	H	V	30.07	33.01	Pass
			H	27.26		
		E1	V	25.01		
			H	27.14		
		E2	V	22.71		
			H	28.29		

### 4.8. Radiated Out of Band Emissions

#### 4.8.1. Limit

According to FCC section 22.917(a) and section 24.238(a), 27.53(g) the power of any emission outside of the authorized operating frequency ranges must be attenuated below the transmitting power (P) by a factor of at least  $43+10*\log(P)$ dB. This calculated to be -13dBm.

The spurious emission with frequency band 1900 according to FCC section 2.1057.

#### 4.8.2. Test Setup

Below 1GHz

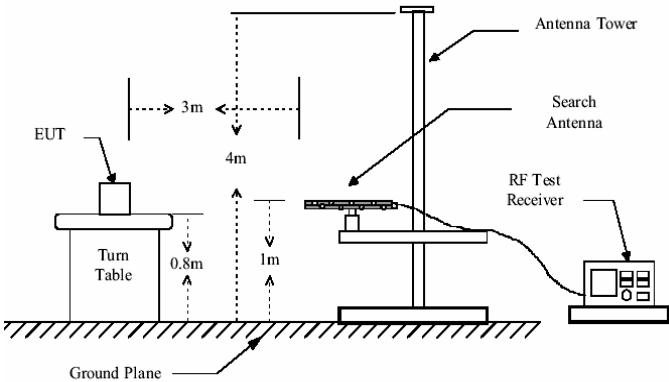

Above 1GHz

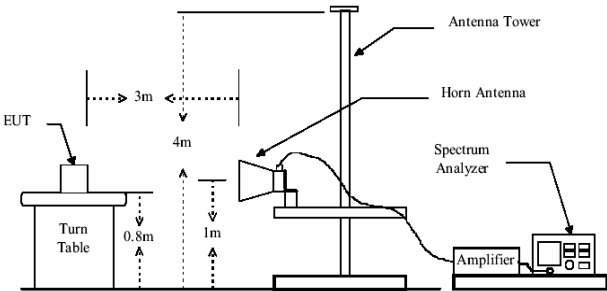

Substituted method:

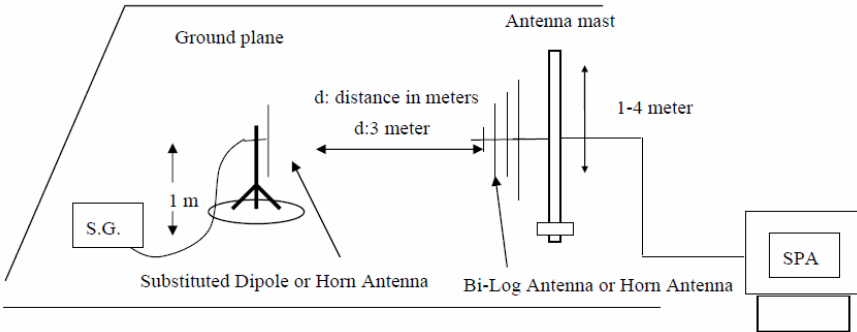

### 4.8.3. Measurement Procedure

The EUT was placed on a non-conductive, The measurement antenna was placed at a distance of 3 meters from the EUT. During the tests, the antenna height and the EUT azimuth were varied in order to identify the maximum level of emissions from the EUT. This maximization process was repeated with the EUT positioned in each of its three orthogonal orientations. all test in Full-Anechoic Chamber.

The frequency range up to tenth harmonic was investigated for each of three fundamental frequency

(low, middle and high channels). Once spurious emission was identified, the power of the emission was determined using the substitution method.

The spurious emissions attenuation was calculated as the difference between radiated power at the fundamental frequency and the spurious emissions frequency.

The emission below 30MHz is background, so no data show it.

$EIRP = S.G. \text{ output (dBm)} + \text{Antenna Gain(dBi)} - \text{Cable Loss (dB)}$

Note: Measurement Uncertainty:  $\pm 3.6$  dB.

Band	Frequency (MHz)	Spurious Emission		Limit (dBm)	Result
		Polarization	Level(dBm)		
GSM 850 Lowest	142.18	Vertical	-64.98	-13	PASS
	1648.40	Vertical	-24.24		
	2472.60	Vertical	-31.64		
	3296.80	Vertical	-33.16		
	4121.00	Vertical	-41.63		
	4945.20	Vertical	-35.63		
	278.81	Horizontal	-68.91		
	2472.60	Horizontal	-28.67		
	3296.80	Horizontal	-33.86		
	4121.00	Horizontal	-41.14		
	4945.20	Horizontal	-44.64		
5769.40	Horizontal	-38.27			

Band	Frequency (MHz)	Spurious Emission		Limit (dBm)	Result
		Polarization	Level(dBm)		
GSM 850 Middle	142.02	Vertical	-68.12	-13	PASS
	1673.20	Vertical	-27.65		
	2509.80	Vertical	-28.12		
	3346.40	Vertical	-36.26		
	4183.00	Vertical	-43.65		
	5019.60	Vertical	-38.87		
	241.21	Horizontal	-72.25		
	1673.20	Horizontal	-25.15		
	2509.80	Horizontal	-28.76		
	3346.40	Horizontal	-44.26		
	4183.00	Horizontal	-45.86		
5019.60	Horizontal	-35.74			

Band	Frequency (MHz)	Spurious Emission		Limit (dBm)	Result
		Polarization	Level(dBm)		
GSM 850 Highest	167.02	Vertical	-70.21	-13	PASS
	1697.60	Vertical	-26.34		
	2546.40	Vertical	-28.67		
	3395.20	Vertical	-32.57		
	4244.00	Vertical	-37.25		
	5092.80	Vertical	-42.75		
	247.21	Horizontal	-72.37		
	1697.60	Horizontal	-24.41		
	2546.40	Horizontal	-29.54		
	3395.20	Horizontal	-34.26		
	4244.00	Horizontal	-46.21		
5092.80	Horizontal	-48.64			



Band	Frequency (MHz)	Spurious Emission		Limit (dBm)	Result
		Polarization	Level(dBm)		
PCS1900 Lowest	78.93	Vertical	-70.13	-13	PASS
	3700.40	Vertical	-42.42		
	5550.60	Vertical	-42.43		
	7400.80	Vertical	-35.53		
	9251.00	Vertical	-38.54		
	11101.20	Vertical	-37.23		
	267.91	Horizontal	-73.34		
	3700.40	Horizontal	-44.26		
	5550.60	Horizontal	-43.65		
	7400.80	Horizontal	-37.23		
	9251.00	Horizontal	-42.35		
	11101.20	Horizontal	-39.12		

Band	Frequency (MHz)	Spurious Emission		Limit (dBm)	Result
		Polarization	Level(dBm)		
PCS1900 Middle	74.29	Vertical	-71.15	-13	PASS
	3760.00	Vertical	-43.36		
	5640.00	Vertical	-42.32		
	7520.00	Vertical	-38.17		
	9400.00	Vertical	-37.25		
	11280.00	Vertical	-38.64		
	213.03	Horizontal	-73.13		
	3760.00	Horizontal	-42.12		
	5640.00	Horizontal	-42.18		
	7520.00	Horizontal	-34.12		
	9400.00	Horizontal	-38.26		
	11280.00	Horizontal	-37.01		

Band	Frequency (MHz)	Spurious Emission		Limit (dBm)	Result
		Polarization	Level(dBm)		
PCS1900 Highest	71.98	Vertical	-72.63	-13	PASS
	3819.60	Vertical	-43.32		
	5729.40	Vertical	-37.78		
	7639.20	Vertical	-33.74		
	9549.00	Vertical	-39.34		
	11458.80	Vertical	-39.65		
	267.29	Horizontal	-72.31		
	3819.60	Horizontal	-41.24		
	5729.40	Horizontal	-36.63		
	7639.20	Horizontal	-32.53		
	9549.00	Horizontal	-37.68		
	11458.80	Horizontal	-37.58		

## **5. PHOTOGRAPHS OF TEST SET-UP**

Reference to the test report No. 14KWE05143501F

## **6. PHOTOGRAPHS OF THE EUT**

Reference to the test report No. 14KWE05143501F

END.