

FCC 47 CFR PART 15 SUBPART C

CERTIFICATION TEST REPORT

For

VoIP Wireless Router

MODEL No.: FWR7100, FWR7101, FWR7102, FWR8100, FWR8101,
FWR8102

FCC ID: 2AATV-FWR7102

Trade Mark: N/A

REPORT NO.: ES160704017E

ISSUE DATE: August 06, 2016

Prepared for

Flyingvoice Technology Co., Ltd.

Room 202, Chuangxin Bldg A#, No.12 Hongda North Rd, BDA, Beijing, China

Prepared by

SHENZHEN EMTEK CO., LTD

Bldg 69, Majialong Industry Zone, Nanshan District,
Shenzhen, Guangdong, China

TEL: 86-755-26954280

FAX: 86-755-26954282

TABLE OF CONTENTS

| | | |
|----------|---|-----------|
| 1 | TEST RESULT CERTIFICATION | 3 |
| 2 | EUT TECHNICAL DESCRIPTION | 4 |
| 3 | SUMMARY OF TEST RESULT | 5 |
| 4 | TEST METHODOLOGY | 6 |
| 4.1 | GENERAL DESCRIPTION OF APPLIED STANDARDS | 6 |
| 4.2 | MEASUREMENT EQUIPMENT USED | 6 |
| 4.3 | DESCRIPTION OF TEST MODES | 7 |
| 5 | FACILITIES AND ACCREDITATIONS | 8 |
| 5.1 | FACILITIES..... | 8 |
| 5.2 | LABORATORY ACCREDITATIONS AND LISTINGS | 8 |
| 6 | TEST SYSTEM UNCERTAINTY | 9 |
| 7 | SETUP OF EQUIPMENT UNDER TEST | 10 |
| 7.1 | RADIO FREQUENCY TEST SETUP 1..... | 10 |
| 7.2 | RADIO FREQUENCY TEST SETUP 2..... | 10 |
| 7.3 | CONDUCTED EMISSION TEST SETUP | 12 |
| 7.4 | BLOCK DIAGRAM CONFIGURATION OF TEST SYSTEM..... | 13 |
| 7.5 | SUPPORT EQUIPMENT..... | 13 |
| 8 | TEST REQUIREMENTS..... | 14 |
| 8.1 | DTS (6DB) BANDWIDTH..... | 14 |
| 8.2 | MAXIMUM PEAK CONDUCTED OUTPUT POWER | 32 |
| 8.3 | MAXIMUM POWER SPECTRAL DENSITY | 34 |
| 8.4 | UNWANTED EMISSIONS IN NON-RESTRICTED FREQUENCY BANDS..... | 52 |
| 8.5 | RADIATED SPURIOUS EMISSION | 58 |
| 8.6 | CONDUCTED EMISSIONS TEST | 78 |
| 8.7 | ANTENNA APPLICATION | 83 |

1 TEST RESULT CERTIFICATION

Applicant: Flyingvoice Technology Co., Ltd.
Room 202, Chuangxin Bldg A#, No.12 Hongda North Rd, BDA, Beijing, China

Manufacturer: Flyingvoice Technology Co., Ltd.
Room 202, Chuangxin Bldg A#, No.12 Hongda North Rd, BDA, Beijing, China

EUT Description: VoIP Wireless Router

Model Number: FWR7100, FWR7101, FWR7102, FWR8100, FWR8101, FWR8102
(Note: These models are identical in circuitry and electrical, mechanical and physical construction; the differences are the color and model no. for trading purpose. We prepare FWR7102 for test, and the worst result recorded in the report.)

File Number: ES160704017E

Date of Test: July 05, 2016 to August 06, 2016

Measurement Procedure Used:

| APPLICABLE STANDARDS | |
|---|-------------|
| STANDARD | TEST RESULT |
| FCC 47 CFR Part 2, Subpart J FCC 47 CFR Part 15, Subpart C | PASS |

The above equipment was tested by SHENZHEN EMTEK CO., LTD. The test data, data evaluation, test procedures, and equipment configurations shown in this report were made in accordance with the procedures given in ANSI C63.10 (2013) and the energy emitted by the sample EUT tested as described in this report is in compliance with the requirements of FCC Rules Part 2 and Part 15.247

The test results of this report relate only to the tested sample identified in this report.

Date of Test : July 05, 2016 to August 06, 2016

Prepared by : 
Sevin Li/Editor

Reviewer : 
Joe Xia/Supervisor

Approve & Authorized Signer : 
Lisa Wang/Manager

2 EUT TECHNICAL DESCRIPTION

| Characteristics | Description |
|---------------------------------|---|
| Device Type | Wifi 2.4G Device |
| IEEE 802.11 WLAN Mode Supported | <input checked="" type="checkbox"/> 802.11b(20MHz bandwidth) <input checked="" type="checkbox"/> 802.11g(20MHz bandwidth) <input checked="" type="checkbox"/> 802.11n(20MHz bandwidth) <input checked="" type="checkbox"/> 802.11n(40MHz bandwidth) |
| Data Rate | <input checked="" type="checkbox"/> 802.11 b:1,2,5.5,11Mbps <input checked="" type="checkbox"/> 802.11 g:6,9,12,18,24,36,48,54Mbps <input checked="" type="checkbox"/> 802.11n(HT20):MCS0-MCS15 <input checked="" type="checkbox"/> 802.11n(HT40):MCS0-MCS15 |
| MIMO Mode | Support |
| Modulation | DSSS with DBPSK/DQPSK/CCK for 802.11b OFDM with BPSK/QPSK/16QAM/64QAM for 802.11g/n |
| Operating Frequency Range | <input checked="" type="checkbox"/> 2412-2462MHz for 802.11b/g <input checked="" type="checkbox"/> 2412-2462MHz for 802.11n(HT20) <input checked="" type="checkbox"/> 2422-2452MHz for 802.11n(HT40) |
| Number of Channels | <input checked="" type="checkbox"/> 11 channels for 802.11b/g <input checked="" type="checkbox"/> 11 channels for 802.11n(HT20) <input checked="" type="checkbox"/> 7 channels for 802.11n(HT40) |
| Transmit Power Max | 16.71dBm for 802.11b 19.75dBm for 802.11g 22.07dBm for 802.11n(HT20) 20.34dBm for 802.11n(HT40) |
| Antenna Type | PiFa antenna |
| Smart system | <input checked="" type="checkbox"/> SISO for 802.11b/g/n <input checked="" type="checkbox"/> MIMO for 802.11n |
| Antenna Gain | WIFI antenna A: 2.5dBi WIFI antenna B: 2.5dBi |
| Array gain | ≈5.51dBi |
| Power supply | <input type="checkbox"/> DC supply: |
| | <input checked="" type="checkbox"/> Adapter1 supply: Model: S12B22-120A100-C4 INPUT: 100-240~50/60Hz, Max 0.6A OUTPUT: 12V/1A <input checked="" type="checkbox"/> Adapter2 supply: Model: NBS05B050100VU INPUT: 100-240~50/60Hz 0.2A OUTPUT: 5V/1A |

Note: for more details, please refer to the User's manual of the EUT.

3 SUMMARY OF TEST RESULT

| FCC Part Clause | Test Parameter | Verdict | Remark |
|--|---|---------|--------|
| 15.247(a)(2) | DTS (6dB) Bandwidth | PASS | |
| 15.247(b)(3) | Maximum Peak Conducted Output Power | PASS | |
| 15.247(e) | Maximum Power Spectral Density Level | PASS | |
| 15.247(d) | Unwanted Emission Into Non-Restricted Frequency Bands | PASS | |
| 15.247(d) 15.209 | Unwanted Emission Into Restricted Frequency Bands (conducted) | PASS | |
| 15.247(d) 15.209 | Radiated Spurious Emission | PASS | |
| 15.207 | Conducted Emission Test | PASS | |
| 15.247(b) | Antenna Application | PASS | |
| NOTE1: N/A (Not Applicable) | | | |
| NOTE2: According to FCC OET KDB 558074, the report use radiated measurements in the restricted frequency bands. In addition, the radiated test is also performed to ensure the emissions emanating from the device cabinet also comply with the applicable limits. | | | |

RELATED SUBMITTAL(S) / GRANT(S):

This submittal(s) (test report) is intended for FCC ID: 2AATV-FWR7102 filing to comply with Section 15.247 of the FCC Part 15, Subpart C Rules.

The system is compliance with Subpart B is authorized under a DOC procedure

4 TEST METHODOLOGY

4.1 GENERAL DESCRIPTION OF APPLIED STANDARDS

According to its specifications, the EUT must comply with the requirements of the following standards:

FCC 47 CFR Part 2, Subpart J

FCC 47 CFR Part 15, Subpart C

FCC KDB 558074 D01 DTS Meas Guidance v03r05

FCC KDB 662911 D01 Multiple Transmitter Output v02r01

FCC KDB 662911 D02 MIMO With Cross Polarized Antenna V01

4.2 MEASUREMENT EQUIPMENT USED

4.2.1 Conducted Emission Test Equipment

| EQUIPMENT TYPE | MFR | MODEL NUMBER | SERIAL NUMBER | LAST CAL. |
|--------------------|-----------------|--------------|---------------|--------------|
| Test Receiver | Rohde & Schwarz | ESCS30 | 828985/018 | May 29, 2016 |
| L.I.S.N. | Schwarzbeck | NNLK8129 | 8129203 | May 28, 2016 |
| 50Ω Coaxial Switch | Anritsu | MP59B | M20531 | May 29, 2016 |
| Pulse Limiter | Rohde & Schwarz | ESH3-Z2 | 100006 | May 28, 2016 |
| Voltage Probe | Rohde & Schwarz | TK9416 | N/A | May 28, 2016 |

4.2.2 Radiated Emission Test Equipment

| EQUIPMENT TYPE | MFR | MODEL NUMBER | SERIAL NUMBER | LAST CAL. |
|-------------------|-----------------|--------------|---------------|--------------|
| EMI Test Receiver | Rohde & Schwarz | ESU | 1302.6005.26 | May 29, 2016 |
| Pre-Amplifier | HP | 8447D | 2944A07999 | May 28, 2016 |
| Bilog Antenna | Schwarzbeck | VULB9163 | 142 | May 28, 2016 |
| Loop Antenna | ARA | PLA-1030/B | 1029 | May 28, 2016 |
| Horn Antenna | Schwarzbeck | BBHA 9170 | BBHA9170399 | May 28, 2016 |
| Horn Antenna | Schwarzbeck | BBHA 9120 | D143 | May 28, 2016 |
| Cable | Schwarzbeck | AK9513 | ACRX1 | May 29, 2016 |
| Cable | Rosenberger | N/A | FP2RX2 | May 29, 2016 |
| Cable | Schwarzbeck | AK9513 | CRPX1 | May 29, 2016 |
| Cable | Schwarzbeck | AK9513 | CRRX2 | May 29, 2016 |

4.2.3 Radio Frequency Test Equipment

| EQUIPMENT TYPE | MFR | MODEL NUMBER | SERIAL NUMBER | LAST CAL. |
|-------------------|---------|--------------|---------------|--------------|
| Spectrum Analyzer | Agilent | E4407B | 88156318 | May 28, 2016 |
| Signal Analyzer | Agilent | N9010A | My53470879 | May 28, 2016 |
| Power meter | Anritsu | ML2495A | 0824006 | May 28, 2016 |
| Power sensor | Anritsu | MA2411B | 0738172 | May 28, 2016 |

Remark: Each piece of equipment is scheduled for calibration once a year.

4.3 DESCRIPTION OF TEST MODES

The EUT has been tested under its typical operating condition.

The EUT configuration for testing is installed on RF field strength measurement to meet the Commissions requirement and operating in a manner which intends to maximize its emission characteristics in a continuous normal application.

The Transmitter was operated in the normal operating mode. The TX frequency was fixed which was for the purpose of the measurements.

Test of channel included the lowest and middle and highest frequency to perform the test, then record on this report.

Those data rates (802.11b: 1 Mbps; 802.11g: 6 Mbps; 802.11n (HT20): MCS0; 802.11n (HT20): MCS15; 802.11n (HT40): MCS0) ; 802.11n (HT40): MCS15) were used for all test.

Pre-defined engineering program for regulatory testing used to control the EUT for staying in continuous transmitting and receiving mode is programmed.

Frequency and Channel list for 802.11 b/g/n (HT20):

| Channel | Frequency (MHz) | Channel | Frequency (MHz) | Channel | Frequency (MHz) |
|---------|-----------------|---------|-----------------|---------|-----------------|
| 1 | 2412 | 5 | 2432 | 9 | 2452 |
| 2 | 2417 | 6 | 2437 | 10 | 2457 |
| 3 | 2422 | 7 | 2442 | 11 | 2462 |
| 4 | 2427 | 8 | 2447 | | |

Frequency and Channel list for 802.11 n (HT40):

| Channel | Frequency (MHz) | Channel | Frequency (MHz) | Channel | Frequency (MHz) |
|---------|-----------------|---------|-----------------|---------|-----------------|
| 3 | 2422 | 5 | 2432 | 8 | 2447 |
| 4 | 2427 | 6 | 2437 | 9 | 2452 |
| | | 7 | 2442 | | |

Test Frequency and Channel for 802.11 b/g/n (HT20):

| Lowest Frequency | | Middle Frequency | | Highest Frequency | |
|------------------|-----------------|------------------|-----------------|-------------------|-----------------|
| Channel | Frequency (MHz) | Channel | Frequency (MHz) | Channel | Frequency (MHz) |
| 1 | 2412 | 6 | 2437 | 11 | 2462 |

Test Frequency and channel for 802.11n (HT40):

| Lowest Frequency | | Middle Frequency | | Highest Frequency | |
|------------------|-----------------|------------------|-----------------|-------------------|-----------------|
| Channel | Frequency (MHz) | Channel | Frequency (MHz) | Channel | Frequency (MHz) |
| 3 | 2422 | 6 | 2437 | 9 | 2452 |

5 FACILITIES AND ACCREDITATIONS

5.1 FACILITIES

All measurement facilities used to collect the measurement data are located at

Bldg 69, Majialong Industry Zone District, Nanshan District, Shenzhen, China

The sites are constructed in conformance with the requirements of ANSI C63.7, ANSI C63.10 and CISPR Publication 22.

5.2 LABORATORY ACCREDITATIONS AND LISTINGS

Site Description

EMC Lab.

: Accredited by CNAS, 2013.10.29

The certificate is valid until 2016.10.28

The Laboratory has been assessed and proved to be in compliance with CNAS-CL01:2006 (identical to ISO/IEC 17025:2005)

The Certificate Registration Number is L2291.

Accredited by TUV Rheinland Shenzhen 2015.4

The Laboratory has been assessed according to the requirements ISO/IEC 17025.

Accredited by FCC, April 17, 2013

The Certificate Registration Number is 709623.

Accredited by FCC, July 24, 2013

The Certificate Registration Number is 406365.

Accredited by Industry Canada, November 29, 2012

The Certificate Registration Number is 4480A.

Name of Firm

: SHENZHEN EMTEK CO., LTD.

Site Location

: Bldg 69, Majialong Industry Zone,
Nanshan District, Shenzhen, Guangdong, China

6 TEST SYSTEM UNCERTAINTY

The following measurement uncertainty levels have been estimated for tests performed on the apparatus:

| Parameter | Uncertainty |
|--------------------------------|---------------------------|
| Radio Frequency | $\pm 1 \times 10^{-5}$ |
| Maximum Peak Output Power Test | $\pm 1.0\text{dB}$ |
| Conducted Emissions Test | $\pm 2.0\text{dB}$ |
| Radiated Emission Test | $\pm 2.0\text{dB}$ |
| Power Density | $\pm 2.0\text{dB}$ |
| Occupied Bandwidth Test | $\pm 1.0\text{dB}$ |
| Band Edge Test | $\pm 3\text{dB}$ |
| All emission, radiated | $\pm 3\text{dB}$ |
| Antenna Port Emission | $\pm 3\text{dB}$ |
| Temperature | $\pm 0.5^{\circ}\text{C}$ |
| Humidity | $\pm 3\%$ |

Measurement Uncertainty for a level of Confidence of 95%

7 SETUP OF EQUIPMENT UNDER TEST

7.1 RADIO FREQUENCY TEST SETUP 1

The WLAN component's antenna ports(s) of the EUT are connected to the measurement instrument per an appropriate attenuator. The EUT is controlled by PC/software to emit the specified signals for the purpose of measurements.

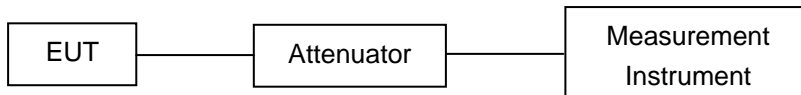

7.2 RADIO FREQUENCY TEST SETUP 2

The test site semi-anechoic chamber has met the requirement of NSA tolerance 4 dB according to the standards: ANSI C63.10. The test distance is 3m. The setup is according to the requirements in Section 13.1.4.1 of ANSI C63.10-2013 and CAN/CSA-CEI/IEC CISPR 22.

Below 30MHz:

The EUT is placed on a turntable 0.8 meters above the ground in the chamber, 3 meter away from the antenna (loop antenna). The Antenna should be positioned with its plane vertical at the specified distance from the EUT and rotated about its vertical axis for maximum response at each azimuth about the EUT. The center of the loop shall be 1 m above the ground. For certain applications, the loop antenna plane may also need to be positioned horizontally at the specified distance from the EUT.

Above 30MHz:

The EUT is placed on a turntable 0.8 meters above the ground in the chamber, 3 meter away from the antenna. The maximal emission value is acquired by adjusting the antenna height, polarisation and turntable azimuth. Normally, the height range of antenna is 1 m to 4 m, the azimuth range of turntable is 0° to 360°, and the receive antenna has two polarizations Vertical (V) and Horizontal (H).

Above 1GHz:

(Note: the FCC's permission to use 1.5m as an alternative per TCBC Conf call of Dec. 2, 2014.)

The EUT is placed on a turntable 1.5 meters above the ground in the chamber, 3 meter away from the antenna. The maximal emission value is acquired by adjusting the antenna height, polarisation and turntable azimuth. Normally, the height range of antenna is 1 m to 4 m, the azimuth range of turntable is 0° to 360°, and the receive antenna has two polarizations Vertical (V) and Horizontal (H).

(a) Radiated Emission Test Set-Up, Frequency Below 30MHz

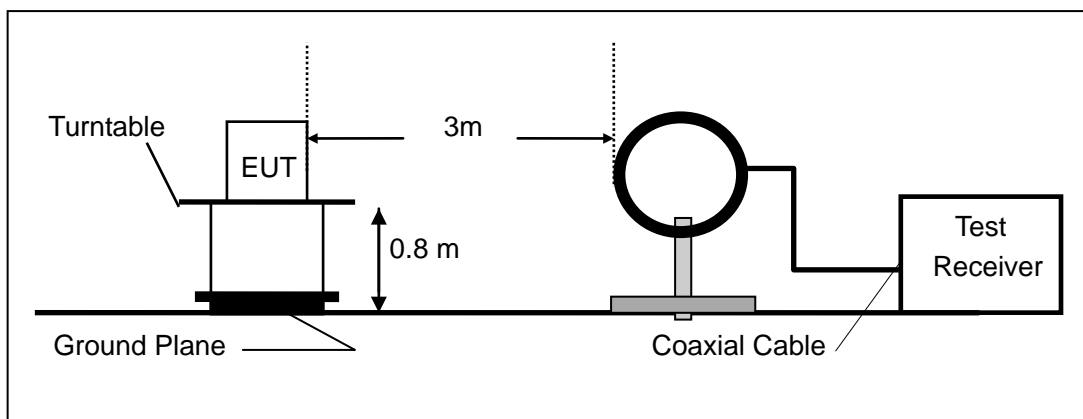

(b) Radiated Emission Test Set-Up, Frequency Below 1000MHz

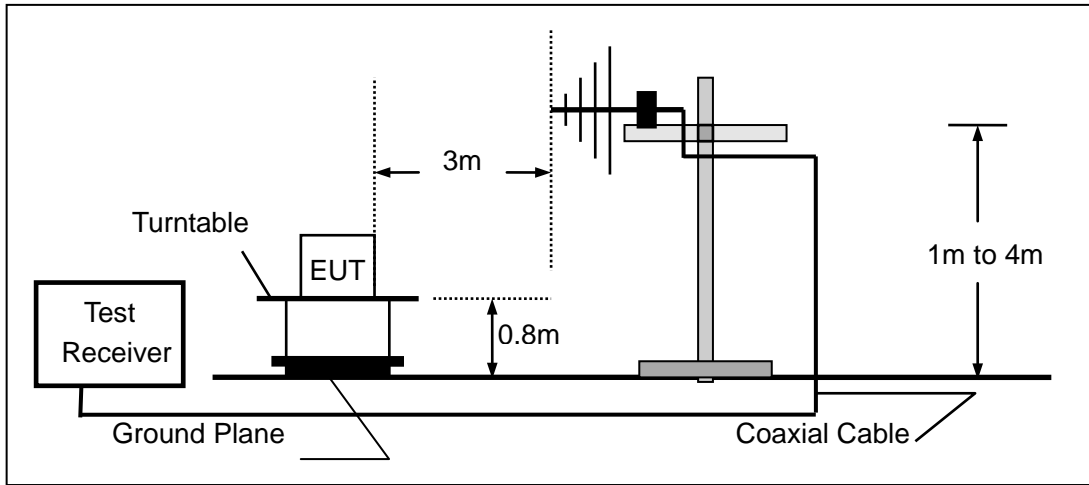

(c) Radiated Emission Test Set-Up, Frequency above 1000MHz

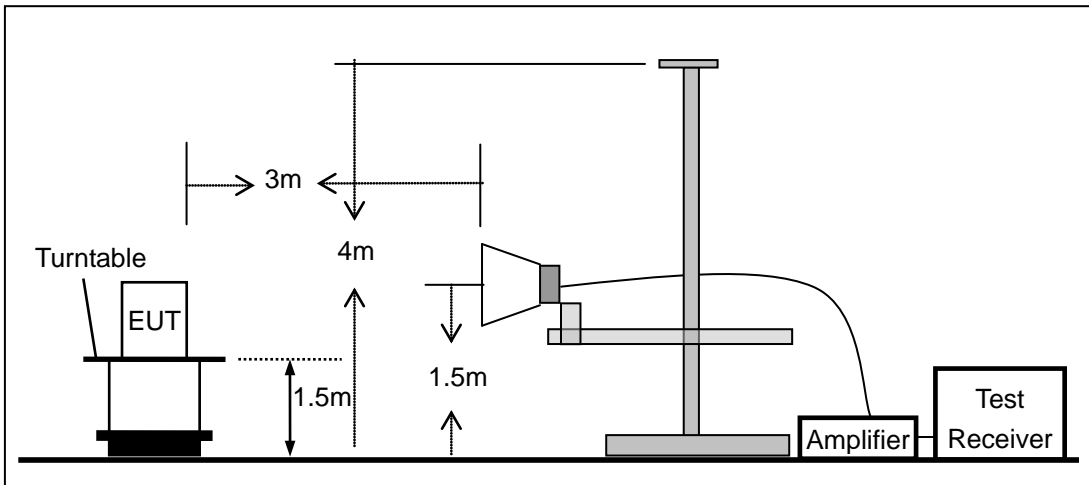

7.3 CONDUCTED EMISSION TEST SETUP

The mains cable of the EUT (maybe per AC/DC Adapter) must be connected to LISN. The LISN shall be placed 0.8 m from the boundary of EUT and bonded to a ground reference plane for LISN mounted on top of the ground reference plane. This distance is between the closest points of the LISN and the EUT. All other units of the EUT and associated equipment shall be at least 0.8m from the LISN.

Ground connections, where required for safety purposes, shall be connected to the reference ground point of the LISN and, where not otherwise provided or specified by the manufacturer, shall be of same length as the mains cable and run parallel to the mains connection at a separation distance of not more than 0.1 m.

According to the requirements in Section 13.1.4.1 of ANSI C63.10-2013 Conducted emissions from the EUT measured in the frequency range between 0.15 MHz and 30 MHz using CISPR Quasi-Peak and average detector mode.

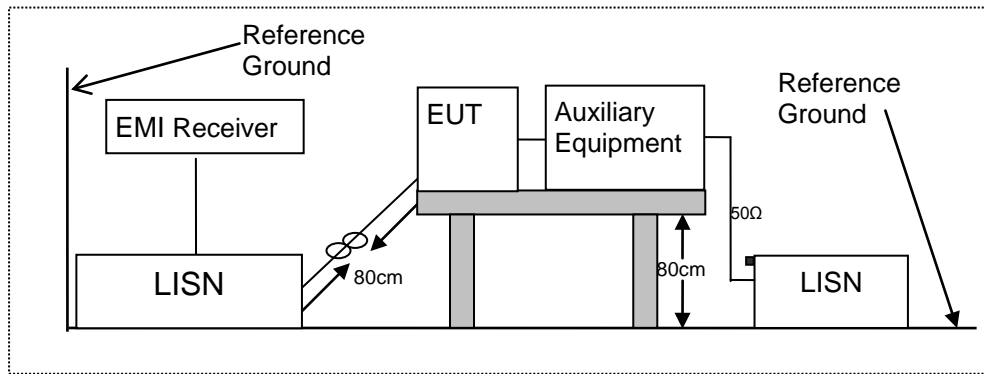

7.4 BLOCK DIAGRAM CONFIGURATION OF TEST SYSTEM

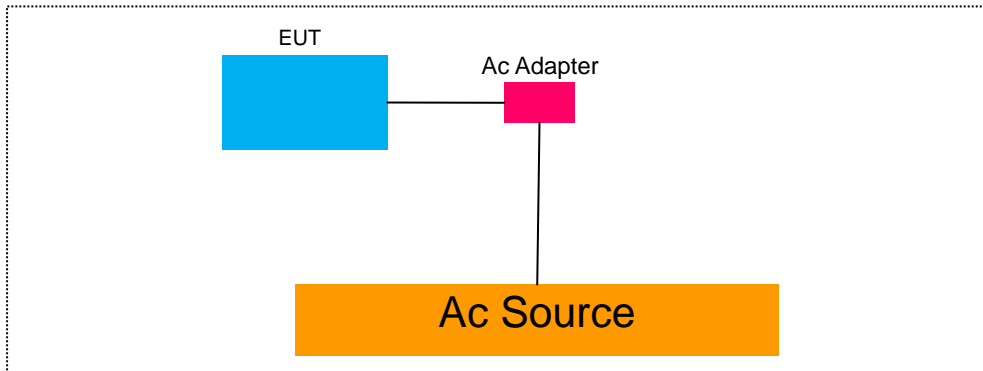

7.5 SUPPORT EQUIPMENT

| Item | Equipment | Mfr/Brand | Model/Type No. | FCC ID | Series No. | Note |
|------|-----------|-----------|----------------|--------|------------|------|
| N/A | N/A | N/A | N/A | N/A | N/A | N/A |

Notes:

1. All the equipment/cables were placed in the worst-case configuration to maximize the emission during the test.
2. Grounding was established in accordance with the manufacturer's requirements and conditions for the intended use.

8 TEST REQUIREMENTS

8.1 DTS (6DB) BANDWIDTH

8.1.1 Applicable Standard

According to FCC Part 15.247(a)(2) and KDB 558074 DTS 01 Meas. Guidance v03r05

8.1.2 Conformance Limit

The minimum -6 dB bandwidth shall be at least 500 kHz.

8.1.3 Test Configuration

Test according to clause 7.1 radio frequency test setup 1

8.1.4 Test Procedure

The EUT was operating in IEEE 802.11b/g/n mode and controlled its channel. Printed out the test result from the spectrum by hard copy function.

The RF output of EUT was connected to the spectrum analyzer by RF cable and attenuator. The path loss was compensated to the results for each measurement.

Set to the maximum power setting and enable the EUT transmit continuously

Set RBW = 100 kHz.

Set the video bandwidth (VBW) =300 kHz.

Set Span=2 times OBW

Set Detector = Peak.

Set Trace mode = max hold.

Set Sweep = auto couple.

Allow the trace to stabilize.

Measure the maximum width of the emission that is constrained by the frequencies associated with the two outermost amplitude points (upper and lower frequencies) that are attenuated by 6 dB relative to the maximum level measured in the fundamental emission.

Measure and record the results in the test report.

8.1.5 Test Results

All modes with adapter1 and adapter2 were tested; the worst case is adapter1 mode that was presented for this item.

| | | | |
|---------------|------|------------|-----------|
| Temperature : | 28°C | Humidity : | 65 % |
| Antenna: | A | Test By: | King Kong |

| Operation Mode | Channel Number | Channel Frequency (MHz) | Measurement Bandwidth (MHz) | Limit (kHz) | Verdict |
|-----------------|----------------|-------------------------|-----------------------------|-------------|---------|
| ☒802.11b | 1 | 2412 | 9.60 | 500 | PASS |
| | 6 | 2437 | 9.61 | 500 | PASS |
| | 11 | 2462 | 10.09 | 500 | PASS |
| ☒802.11g | 1 | 2412 | 15.15 | 500 | PASS |
| | 6 | 2437 | 15.15 | 500 | PASS |
| | 11 | 2462 | 15.15 | 500 | PASS |
| ☒802.11n (HT20) | 1 | 2412 | 15.15 | 500 | PASS |
| | 6 | 2437 | 15.73 | 500 | PASS |
| | 11 | 2462 | 15.73 | 500 | PASS |
| ☒802.11n (HT40) | 3 | 2422 | 35.12 | 500 | PASS |
| | 6 | 2437 | 35.12 | 500 | PASS |
| | 9 | 2452 | 35.16 | 500 | PASS |

| | | | |
|---------------|------|------------|-----------|
| Temperature : | 28°C | Humidity : | 65 % |
| Antenna: | B | Test By: | King Kong |

| Operation Mode | Channel Number | Channel Frequency (MHz) | Measurement Bandwidth (MHz) | Limit (kHz) | Verdict |
|-----------------|----------------|-------------------------|-----------------------------|-------------|---------|
| ☒802.11b | 1 | 2412 | 9.62 | 500 | PASS |
| | 6 | 2437 | 10.05 | 500 | PASS |
| | 11 | 2462 | 9.61 | 500 | PASS |
| ☒802.11g | 1 | 2412 | 15.15 | 500 | PASS |
| | 6 | 2437 | 15.14 | 500 | PASS |
| | 11 | 2462 | 15.15 | 500 | PASS |
| ☒802.11n (HT20) | 1 | 2412 | 15.72 | 500 | PASS |
| | 6 | 2437 | 15.72 | 500 | PASS |
| | 11 | 2462 | 15.14 | 500 | PASS |
| ☒802.11n (HT40) | 3 | 2422 | 35.14 | 500 | PASS |
| | 6 | 2437 | 35.15 | 500 | PASS |
| | 9 | 2452 | 35.13 | 500 | PASS |

For Antenna A

Test Model

DTS (6dB) Bandwidth
802.11b
Channel 1: 2412MHz

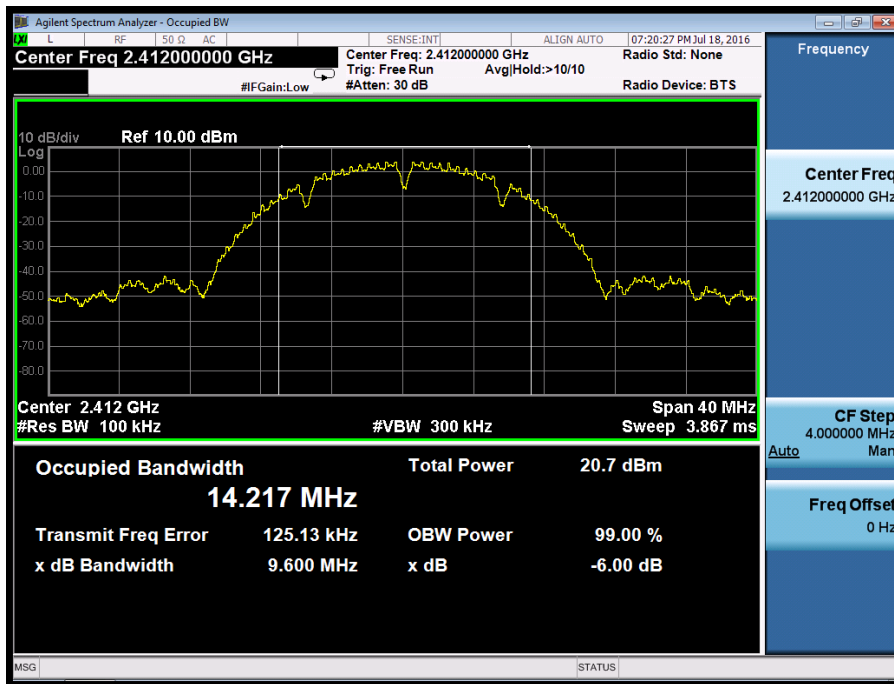

Test Model

DTS (6dB) Bandwidth
802.11b
Channel 6: 2437MHz

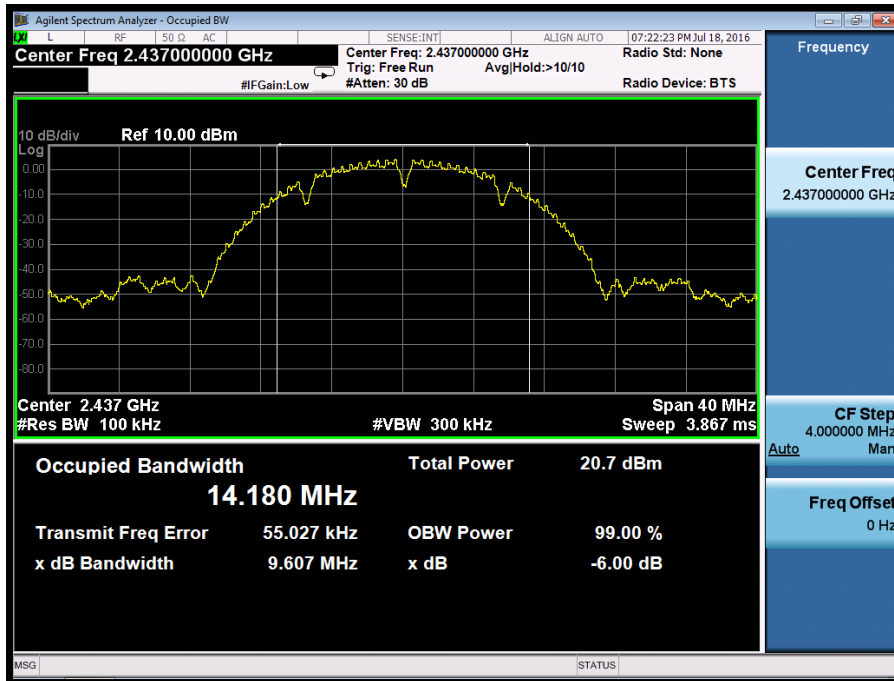

Test Model

DTS (6dB) Bandwidth
802.11b
Channel 11: 2462MHz

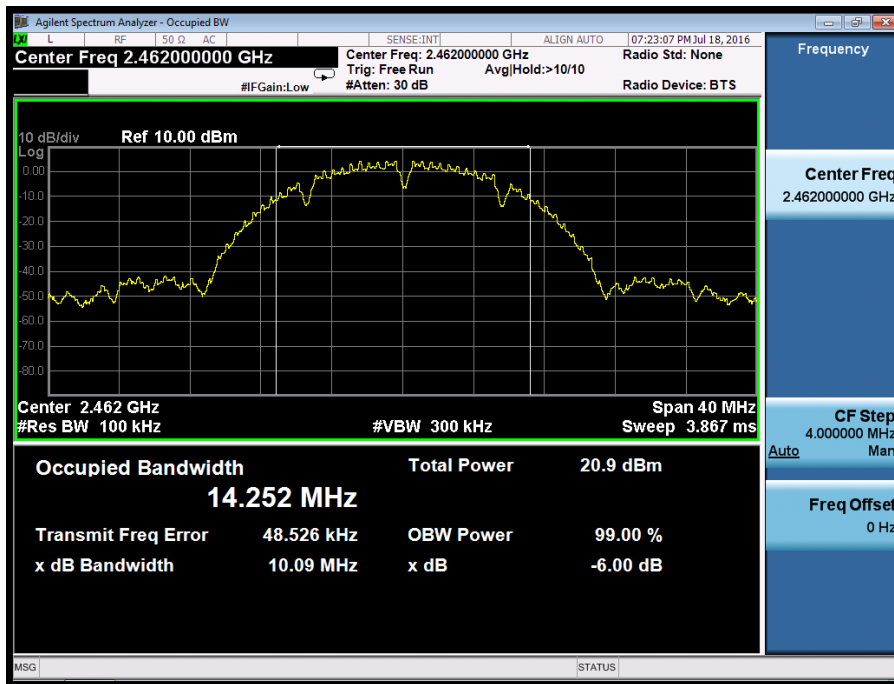

Test Model DTS (6dB) Bandwidth
802.11g
Channel 1: 2412MHz

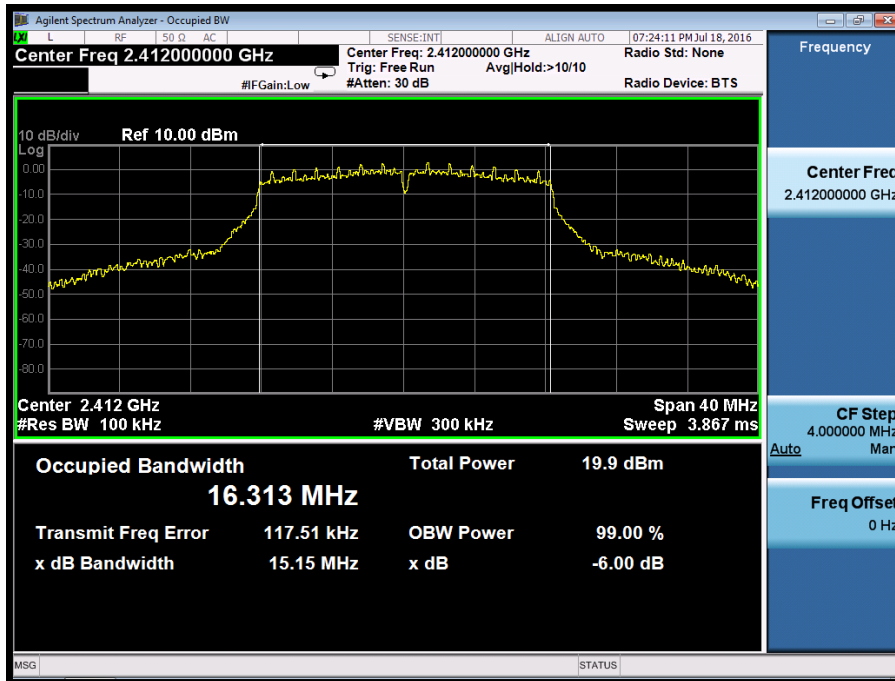

Test Model DTS (6dB) Bandwidth
802.11g
Channel 6: 2437MHz

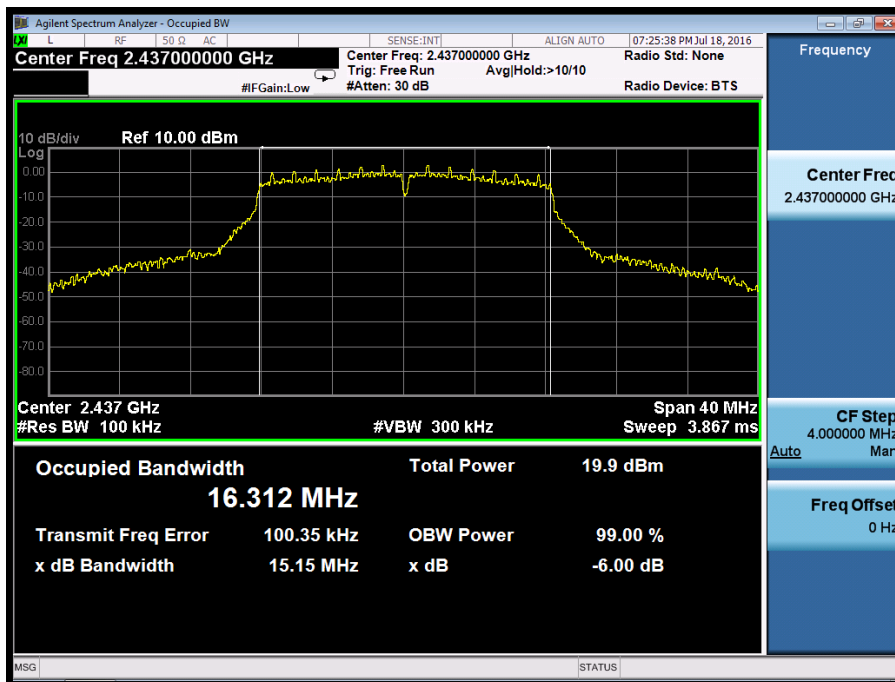

Test Model

DTS (6dB) Bandwidth
802.11g
Channel 11: 2462MHz

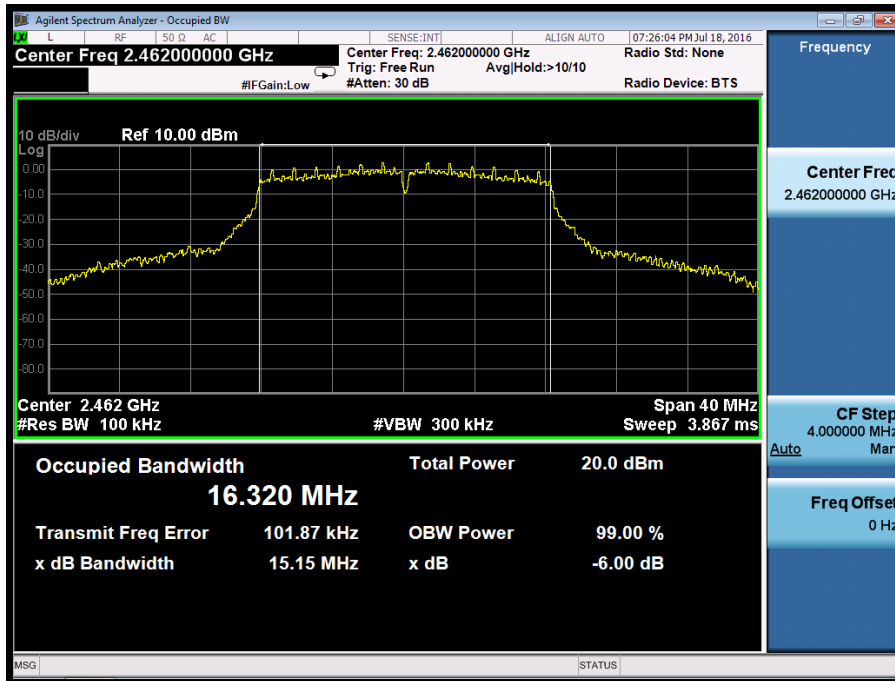

Test Model

DTS (6dB) Bandwidth
802.11n (HT20)
Channel 1: 2412MHz

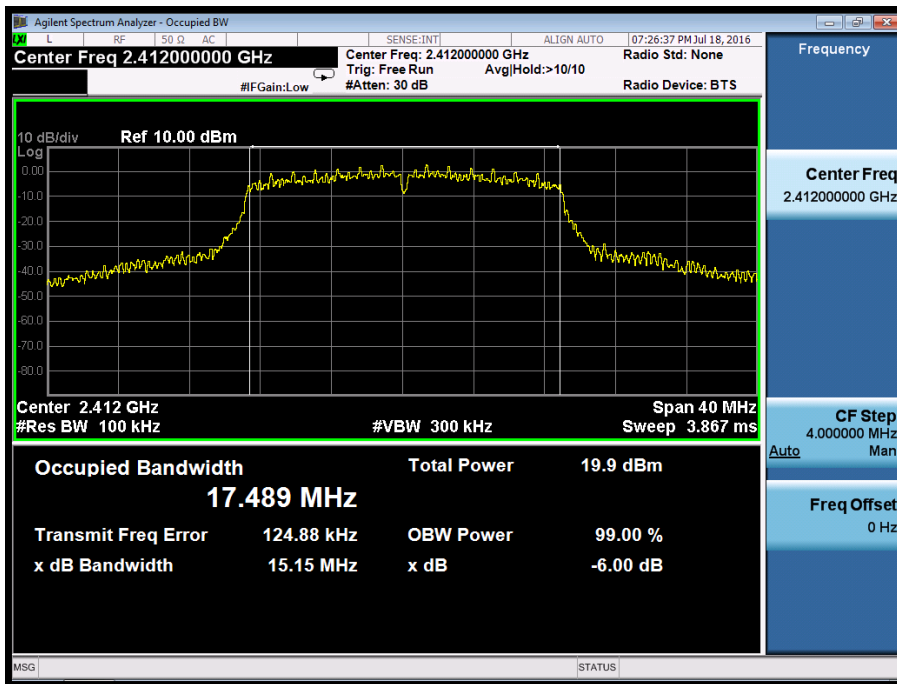

Test Model

DTS (6dB) Bandwidth
802.11n (HT20)
Channel 6: 2437MHz

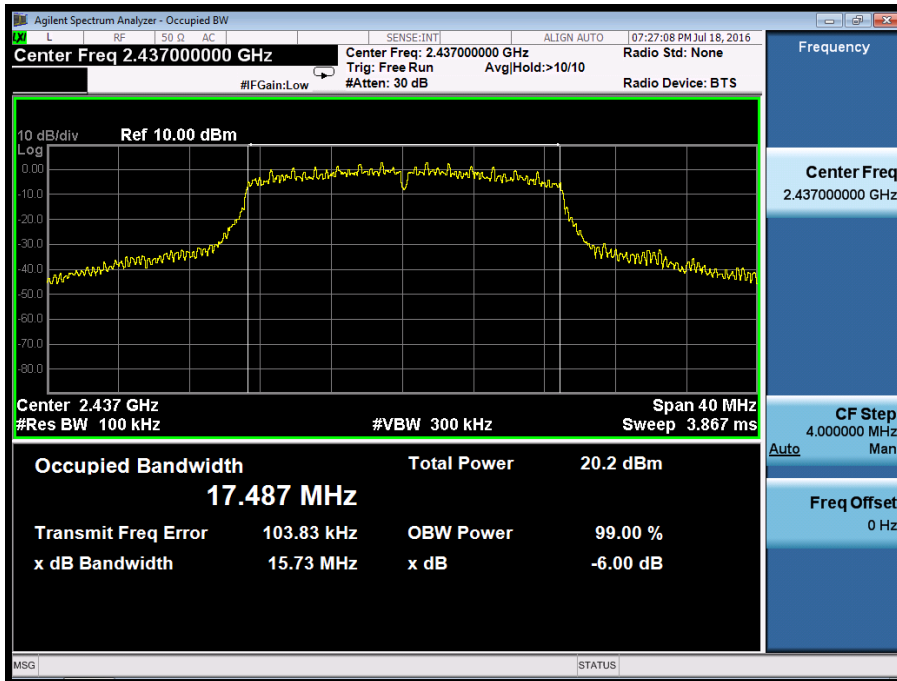

Test Model

DTS (6dB) Bandwidth
802.11n (HT20)
Channel 11: 2462MHz

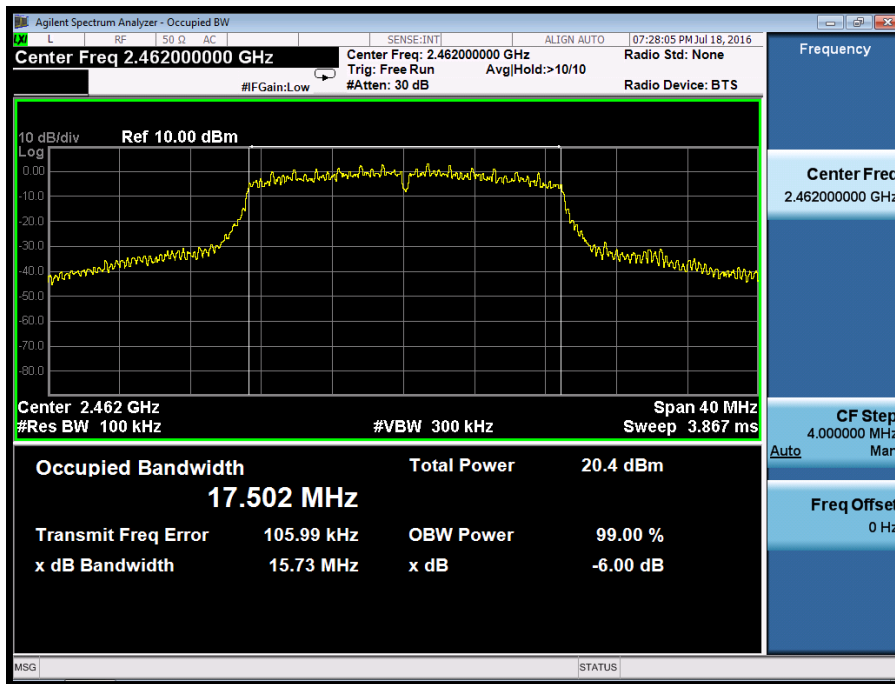

Test Model

DTS (6dB) Bandwidth
802.11n (HT40)
Channel 3: 2422MHz

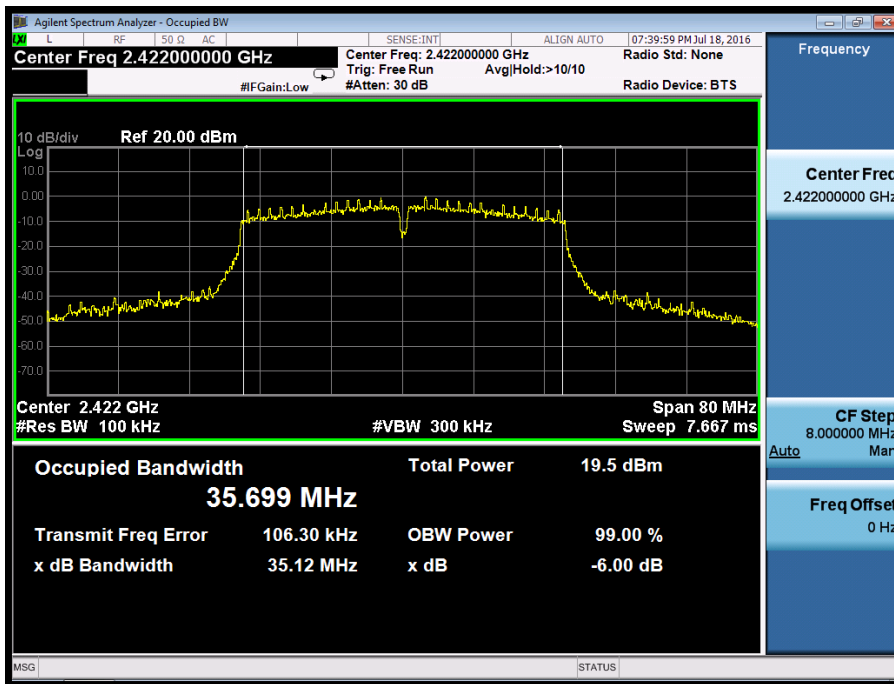

Test Model

DTS (6dB) Bandwidth
802.11n (HT40)
Channel 6: 2437MHz

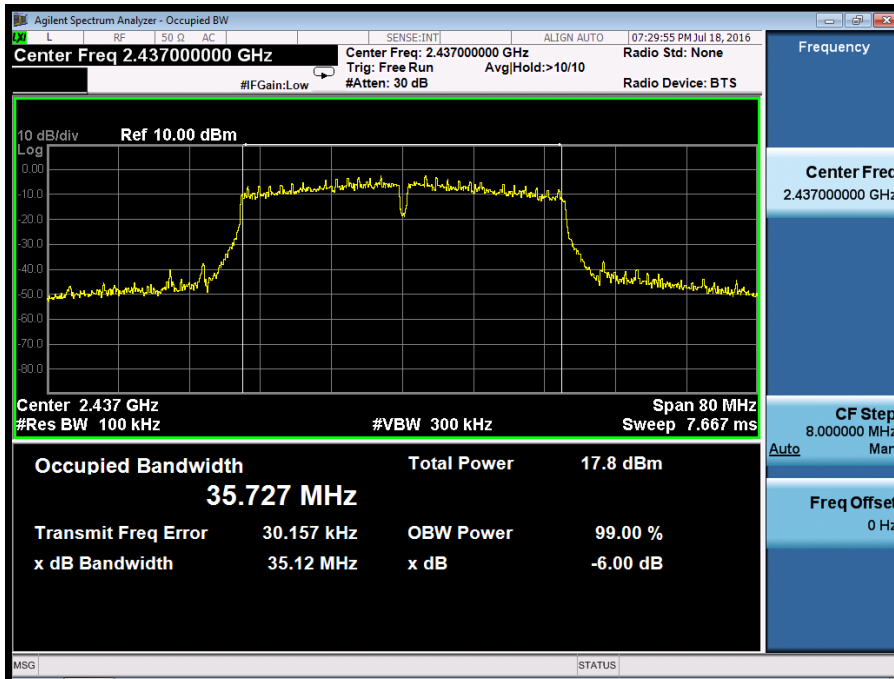

Test Model

DTS (6dB) Bandwidth
802.11n (HT40)
Channel 9: 2452MHz

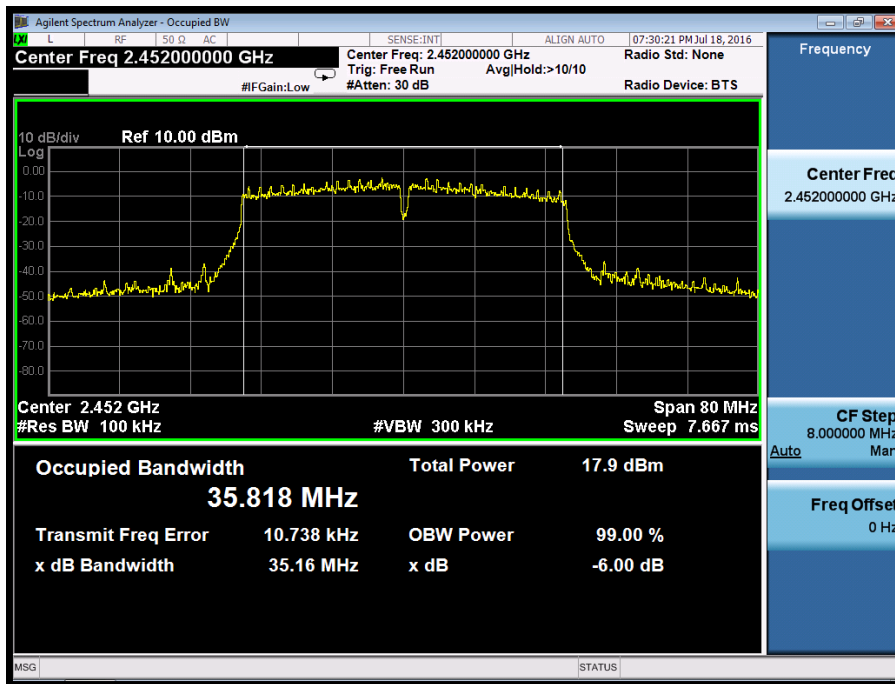

For Antenna B

Test Model

DTS (6dB) Bandwidth
802.11b
Channel 1: 2412MHz

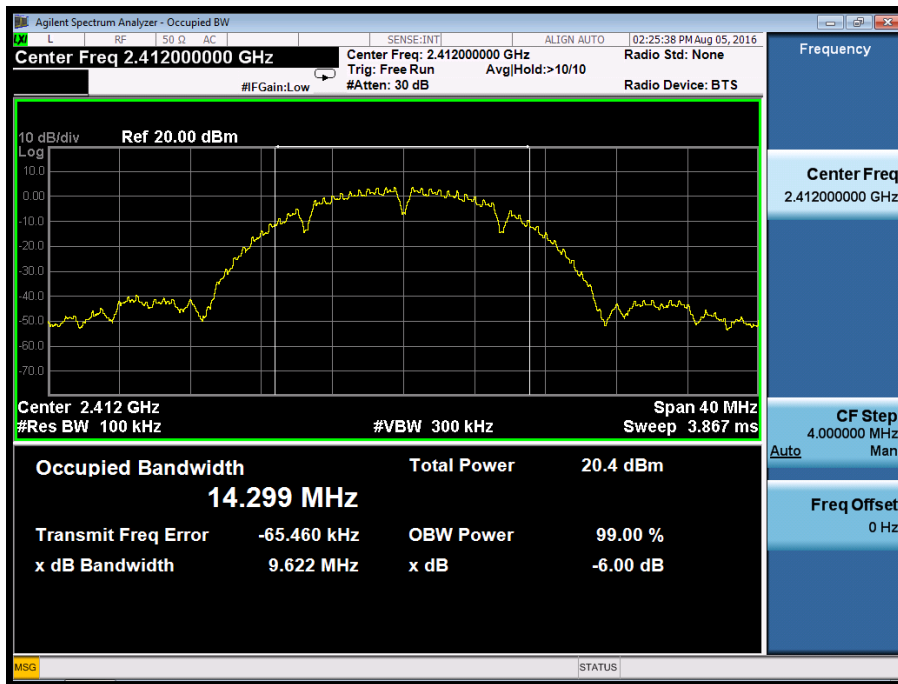

Test Model

DTS (6dB) Bandwidth
802.11b
Channel 6: 2437MHz

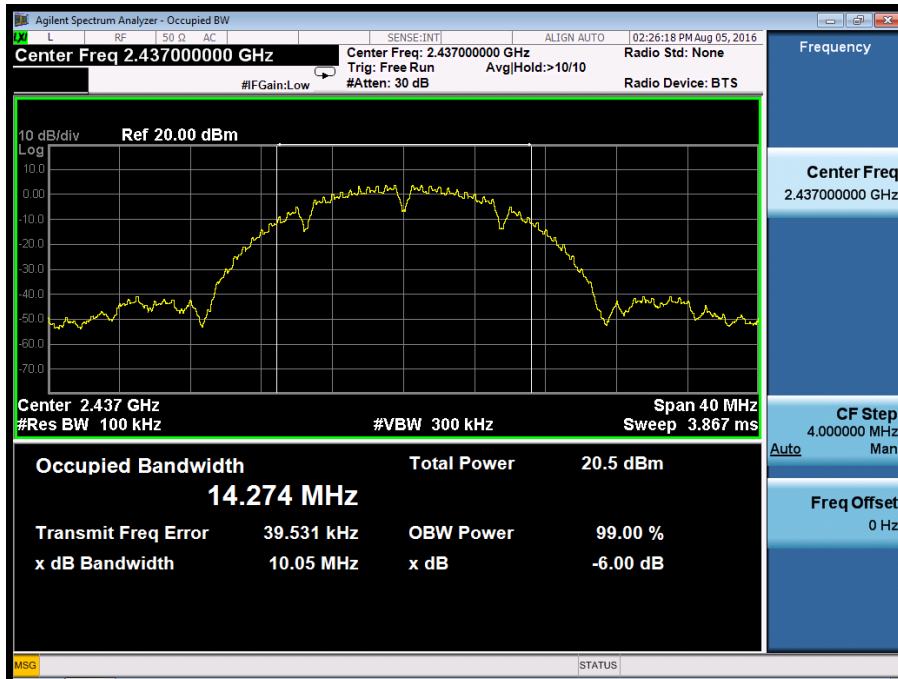

Test Model

DTS (6dB) Bandwidth
802.11b
Channel 11: 2462MHz

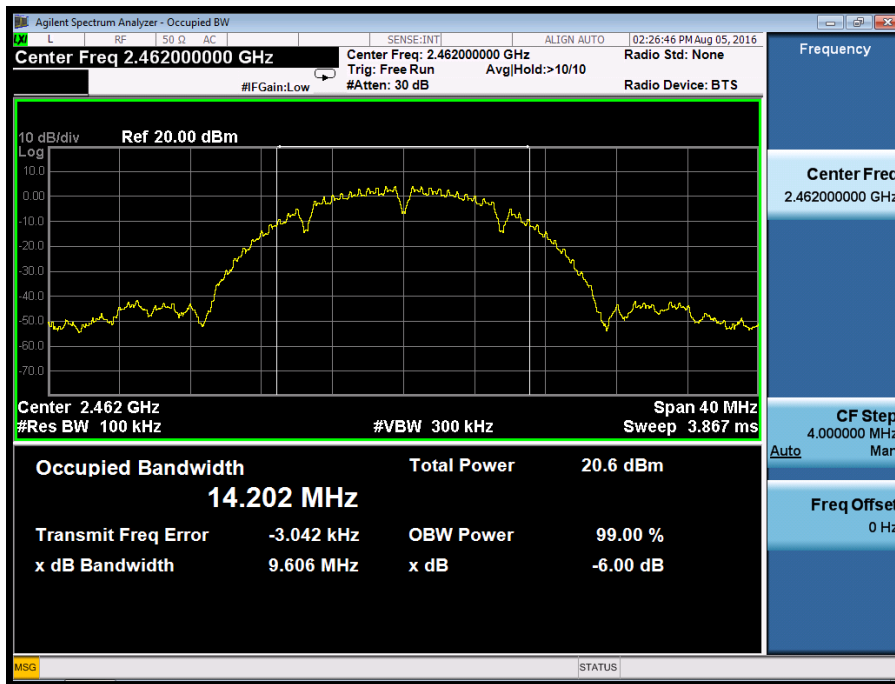

Test Model

DTS (6dB) Bandwidth
802.11g
Channel 1: 2412MHz

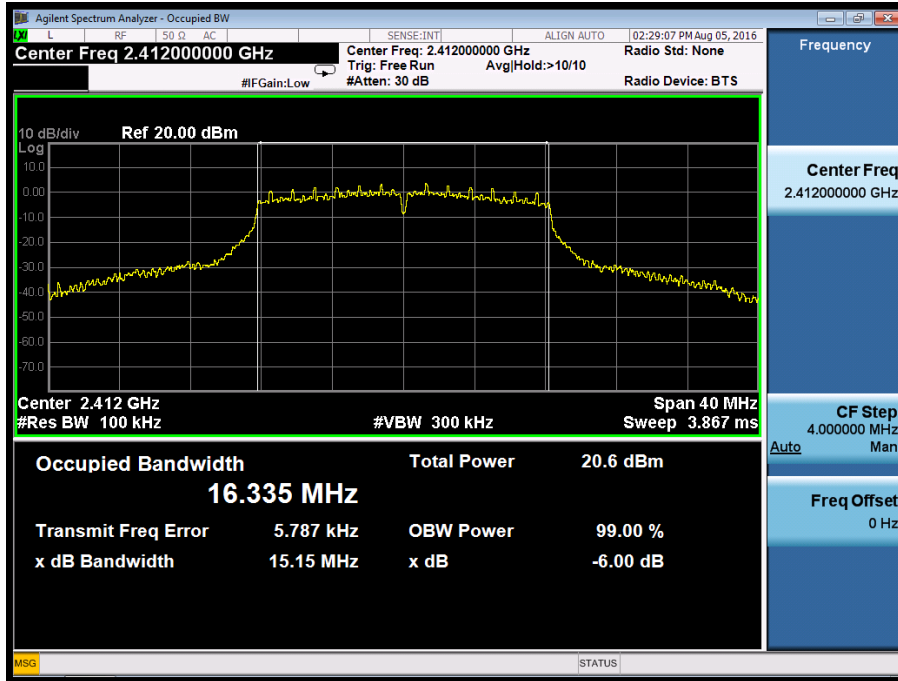

Test Model

DTS (6dB) Bandwidth
802.11g
Channel 6: 2437MHz

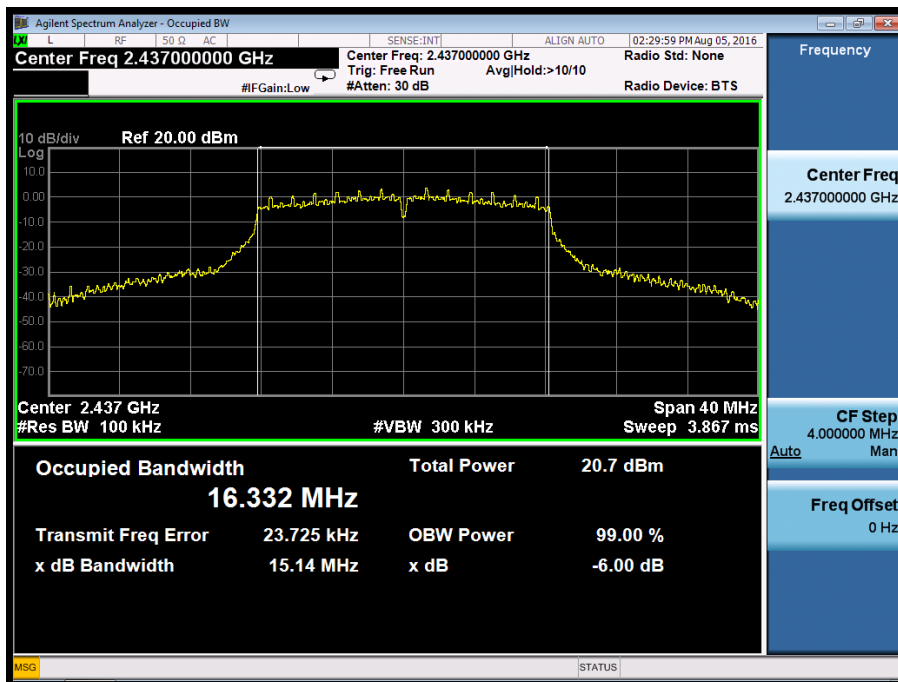

Test Model DTS (6dB) Bandwidth
 802.11g
 Channel 11: 2462MHz

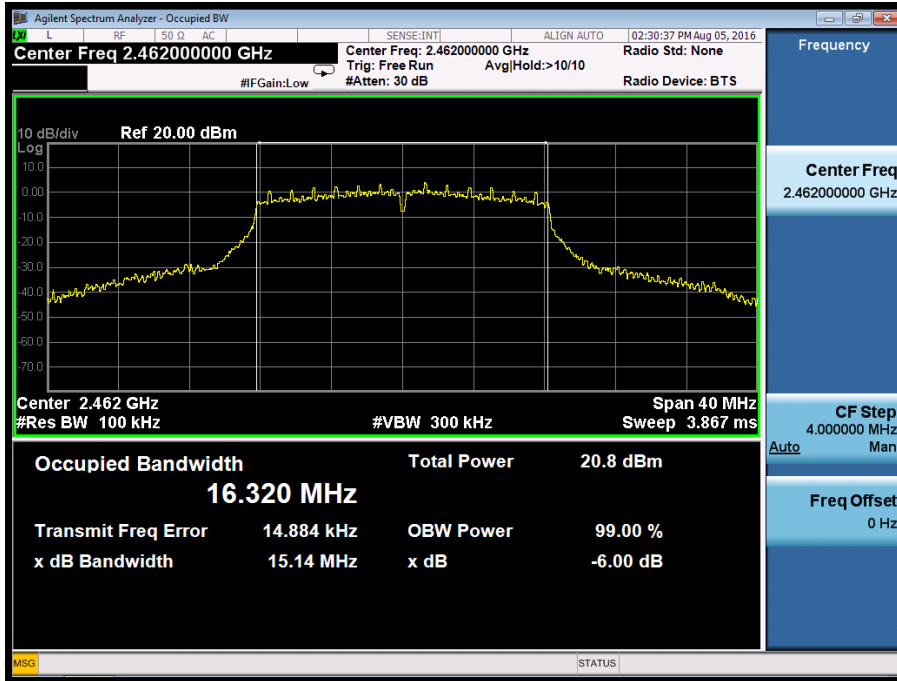

Test Model

DTS (6dB) Bandwidth
802.11n (HT20)
Channel 1: 2412MHz

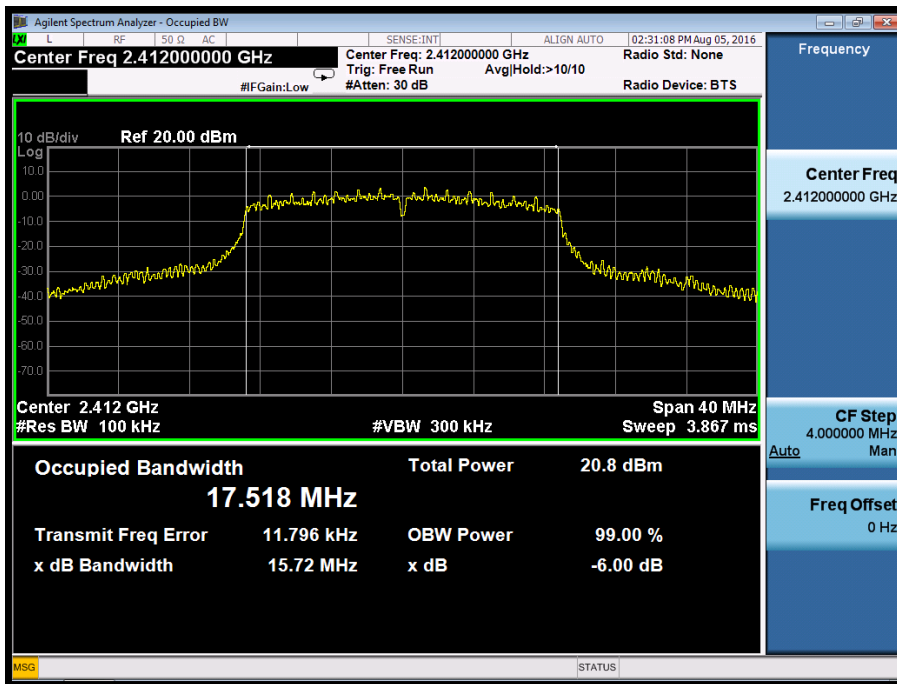

Test Model

DTS (6dB) Bandwidth
802.11n (HT20)
Channel 6: 2437MHz

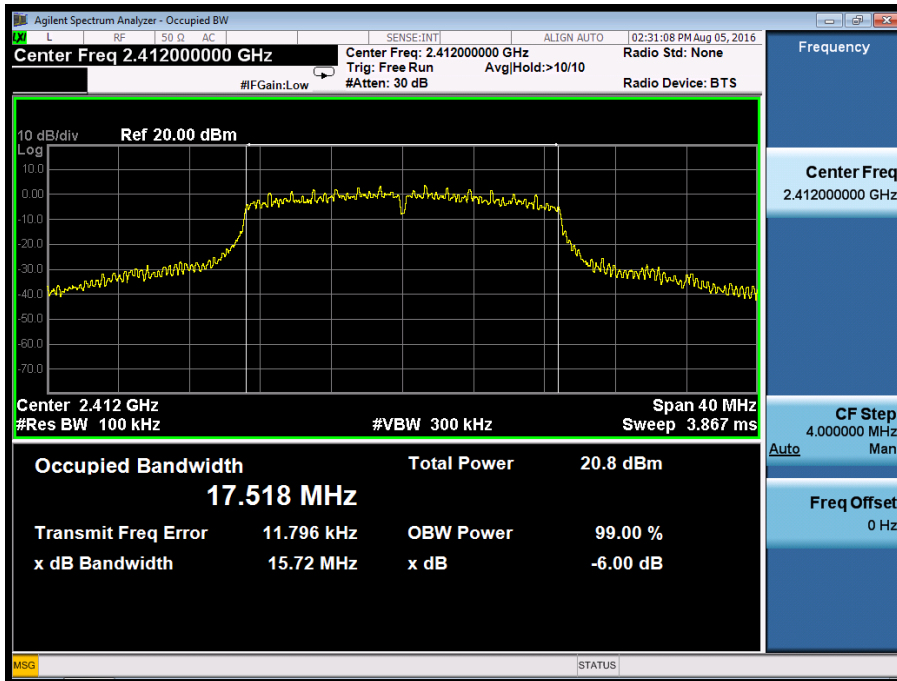

Test Model

DTS (6dB) Bandwidth
802.11n (HT20)
Channel 11: 2462MHz

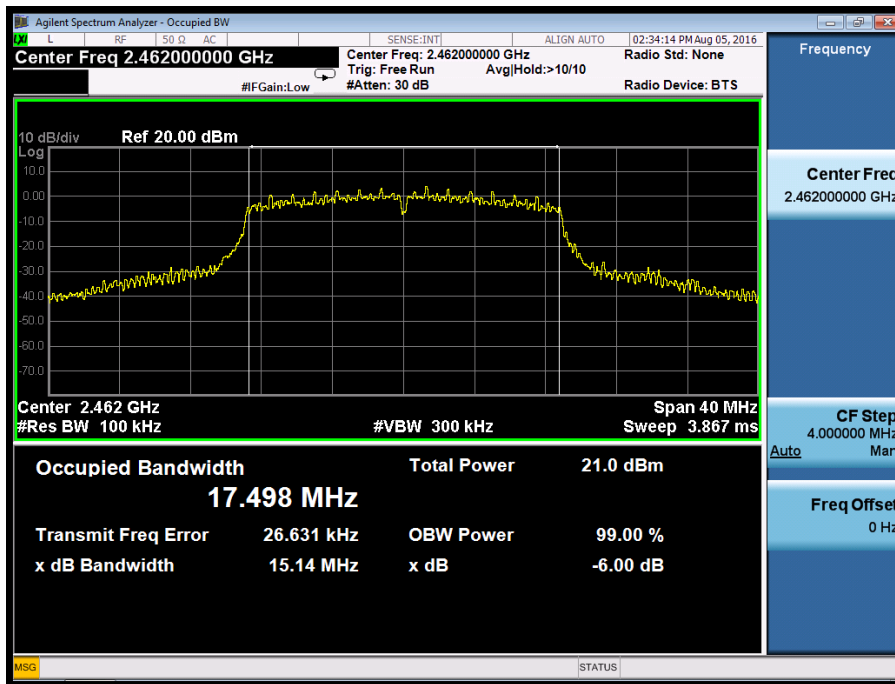

Test Model

DTS (6dB) Bandwidth
802.11n (HT40)
Channel 3: 2422MHz

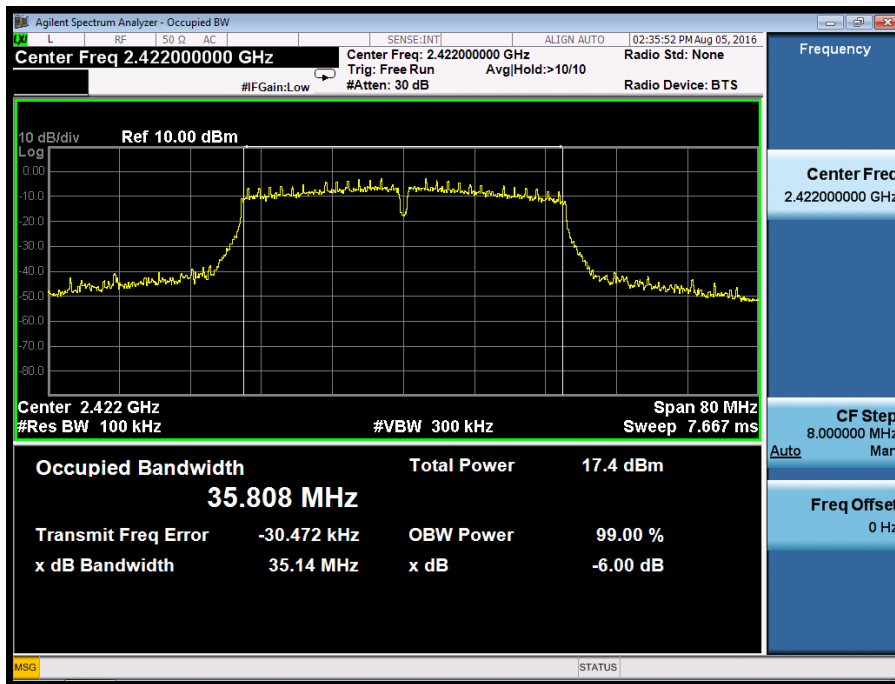

Test Model

DTS (6dB) Bandwidth
802.11n (HT40)
Channel 6: 2437MHz

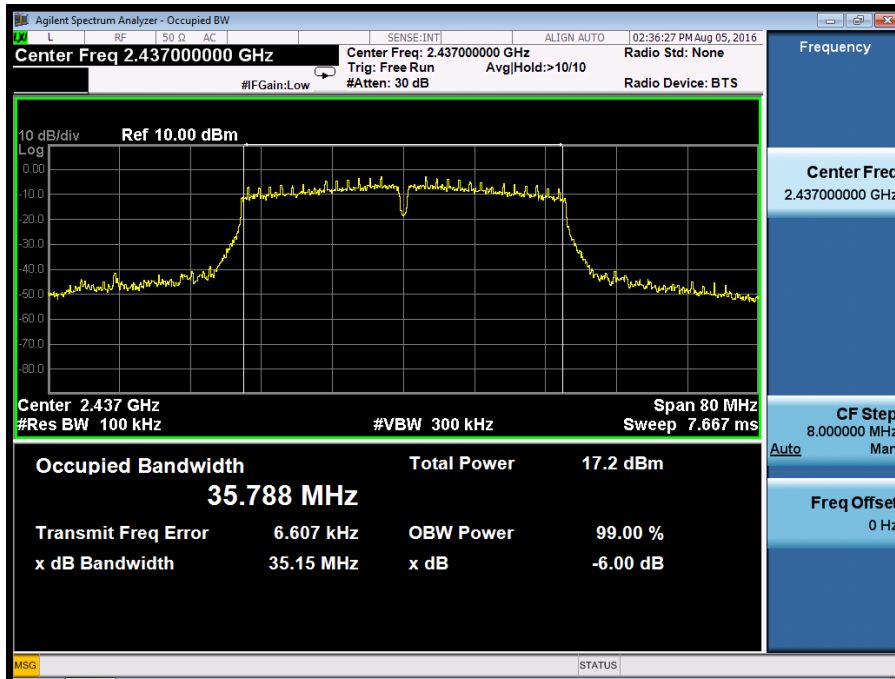

Test Model

DTS (6dB) Bandwidth
802.11n (HT40)
Channel 9: 2452MHz

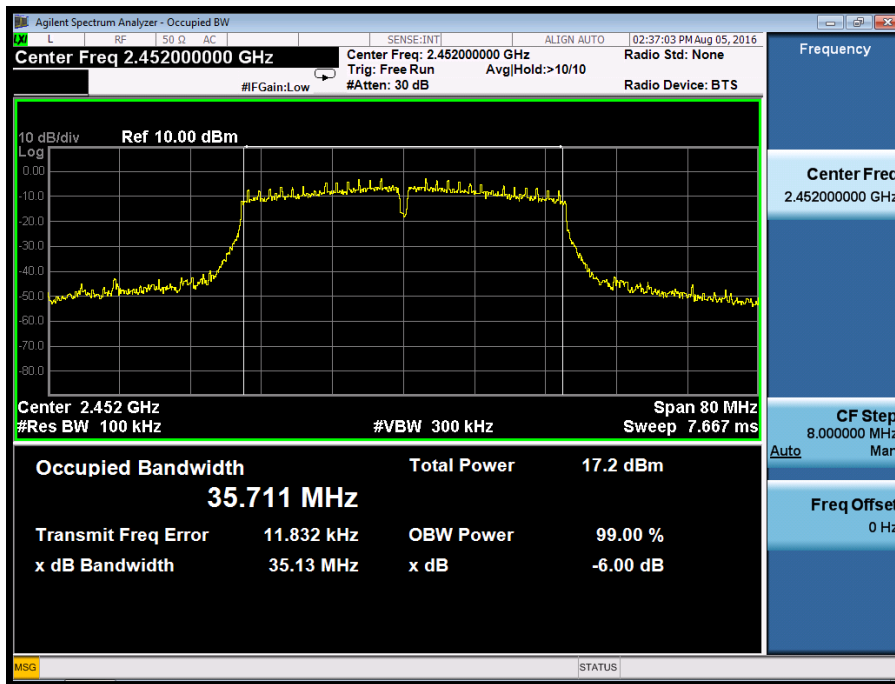

8.2 MAXIMUM PEAK CONDUCTED OUTPUT POWER

8.2.1 Applicable Standard

According to FCC Part 15.247(b)(3) and KDB 558074 DTS 01 Meas. Guidance v03r05

8.2.2 Conformance Limit

The maximum peak conducted output power of the intentional radiator for systems using digital modulation in the 2400 - 2483.5 MHz bands shall not exceed: 1 Watt (30dBm).

8.2.3 Test Configuration

Test according to clause 7.1 radio frequency test setup 1

8.2.4 Test Procedure

■ According to FCC Part15.247(b)(3)

The maximum peak conducted output power may be measured using a broadband peak RF power meter. The power meter shall have a video bandwidth that is greater than or equal to the DTS bandwidth and shall utilize a fast-responding diode detector.

The testing follows KDB 558074 and KDB662911 Measurement Guidelines.

The RF output of EUT was connected to the power meter by RF cable and attenuator. The path loss was compensated to the results for each measurement.

Set to the maximum output power setting and enable the EUT transmit continuously.

Measure the conducted output power with cable loss and record the results in the test report.

Measure and record the results in the report.

■ According to FCC Part 15.247(b)(4):

Conducted output power limit specified in paragraph (b) of this section is based on the use of antennas with directional gains that do not exceed 6 dBi. If transmitting antennas of directional gain greater than 6 dBi are used, the conducted output power from the intentional radiator shall be reduced below the stated values in paragraphs (b)(3) of this section, as appropriate, by the amount in dB that the directional gain of the antenna exceeds 6 dBi.

Note: If antenna Gain exceeds 6 dBi, then Output power Limit=30-(Gain - 6)

8.2.5 Test Results

All modes with adapter1 and adapter2 were tested; the worst case is adapter1 mode that was presented for this item.

| | | | |
|---------------|------|-------------|---------------|
| Temperature : | 28°C | Test Date : | July 18, 2016 |
| Humidity : | 65 % | Test By: | King Kong |
| Antenna: | A | | |

| Operation Mode | Channel Number | Channel Frequency (MHz) | Measurement Level (dBm) | Limit (dBm) | Verdict |
|-----------------|----------------|-------------------------|-------------------------|-------------|---------|
| ☒802.11b | 1 | 2412 | 16.71 | 30 | PASS |
| | 6 | 2437 | 16.69 | 30 | PASS |
| | 11 | 2462 | 16.41 | 30 | PASS |
| ☒802.11g | 1 | 2412 | 19.41 | 30 | PASS |
| | 6 | 2437 | 19.75 | 30 | PASS |
| | 11 | 2462 | 19.32 | 30 | PASS |
| ☒802.11n (HT20) | 1 | 2412 | 19.09 | 30 | PASS |
| | 6 | 2437 | 18.93 | 30 | PASS |
| | 11 | 2462 | 18.81 | 30 | PASS |
| ☒802.11n (HT40) | 3 | 2422 | 17.16 | 30 | PASS |
| | 6 | 2437 | 17.34 | 30 | PASS |
| | 9 | 2452 | 17.09 | 30 | PASS |

| | | | |
|---------------|------|-------------|---------------|
| Temperature : | 28°C | Test Date : | July 18, 2016 |
| Humidity : | 65 % | Test By: | King Kong |
| Antenna: | B | | |

| Operation Mode | Channel Number | Channel Frequency (MHz) | Measurement Level (dBm) | Limit (dBm) | Verdict |
|-----------------|----------------|-------------------------|-------------------------|-------------|---------|
| ☒802.11b | 1 | 2412 | 16.65 | 30 | PASS |
| | 6 | 2437 | 16.44 | 30 | PASS |
| | 11 | 2462 | 16.37 | 30 | PASS |
| ☒802.11g | 1 | 2412 | 19.41 | 30 | PASS |
| | 6 | 2437 | 19.59 | 30 | PASS |
| | 11 | 2462 | 19.27 | 30 | PASS |
| ☒802.11n (HT20) | 1 | 2412 | 19.01 | 30 | PASS |
| | 6 | 2437 | 19.05 | 30 | PASS |
| | 11 | 2462 | 18.62 | 30 | PASS |
| ☒802.11n (HT40) | 3 | 2422 | 17.25 | 30 | PASS |
| | 6 | 2437 | 17.11 | 30 | PASS |
| | 9 | 2452 | 16.91 | 30 | PASS |

| | | | |
|---------------|------|-------------|---------------|
| Temperature : | 28°C | Test Date : | July 18, 2016 |
| Humidity : | 65 % | Test By: | King Kong |
| Antenna: | A+B | | |

| Operation Mode | Channel Number | Channel Frequency (MHz) | Measurement Level (dBm) | Limit (dBm) | Verdict |
|-----------------|----------------|-------------------------|-------------------------|-------------|---------|
| ☒802.11n (HT20) | 1 | 2412 | 22.06 | 30 | PASS |
| | 6 | 2437 | 22.00 | 30 | PASS |
| | 11 | 2462 | 21.73 | 30 | PASS |
| ☒802.11n (HT40) | 3 | 2422 | 20.22 | 30 | PASS |
| | 6 | 2437 | 20.24 | 30 | PASS |
| | 9 | 2452 | 20.01 | 30 | PASS |

8.3 MAXIMUM POWER SPECTRAL DENSITY

8.3.1 Applicable Standard

According to FCC Part 15.247(e) and KDB 558074 DTS 01 Meas. Guidance v03r05

8.3.2 Conformance Limit

The transmitter power spectral density conducted from the transmitter to the antenna shall not be greater than 8 dBm in any 3 kHz band during any time interval of continuous transmission.

8.3.3 Test Configuration

Test according to clause 7.1 radio frequency test setup 1

8.3.4 Test Procedure

This procedure shall be used if maximum peak conducted output power was used to demonstrate compliance

The transmitter output (antenna port) was connected to the spectrum analyzer

Set analyzer center frequency to DTS channel center frequency.

Set the span to 1.5 times the DTS bandwidth.

Set the RBW to: 3 kHz

Set the VBW to: 10 kHz.

Set Detector = peak.

Set Sweep time = auto couple.

Set Trace mode = max hold.

Allow trace to fully stabilize.

Use the peak marker function to determine the maximum amplitude level within the RBW.

Note: If antenna Gain exceeds 6 dBi, then PSD Limit=8-(Gain - 6)

8.3.5 Test Results

All modes with adapter1 and adapter2 were tested; the worst case is adapter1 mode that was reported for this item.

| | | | |
|---------------|------|------------|-----------|
| Temperature : | 28°C | Humidity : | 65 % |
| Antenna: | A | Test By: | King Kong |

| Operation Mode | Channel Number | Channel Frequency (MHz) | Measurement Level (dBm/3kHz) | Limit (dBm/3kHz) | Verdict |
|-----------------|----------------|-------------------------|------------------------------|------------------|---------|
| ☒802.11b | 1 | 2412 | -12.683 | 8 | PASS |
| | 6 | 2437 | -11.860 | 8 | PASS |
| | 11 | 2462 | -12.165 | 8 | PASS |
| ☒802.11g | 1 | 2412 | -14.369 | 8 | PASS |
| | 6 | 2437 | -11.993 | 8 | PASS |
| | 11 | 2462 | -13.156 | 8 | PASS |
| ☒802.11n (HT20) | 1 | 2412 | -13.072 | 8 | PASS |
| | 6 | 2437 | -13.331 | 8 | PASS |
| | 11 | 2462 | -14.061 | 8 | PASS |
| ☒802.11n (HT40) | 3 | 2422 | -16.525 | 8 | PASS |
| | 6 | 2437 | -16.643 | 8 | PASS |
| | 9 | 2452 | -16.263 | 8 | PASS |

Temperature : 28°C Antenna: B
Antenna: B Test By: King Kong

| Operation Mode | Channel Number | Channel Frequency (MHz) | Measurement Level (dBm/3kHz) | Limit (dBm/3kHz) | Verdict |
|-----------------|----------------|-------------------------|------------------------------|------------------|---------|
| ☒802.11b | 1 | 2412 | -11.847 | 8 | PASS |
| | 6 | 2437 | -11.583 | 8 | PASS |
| | 11 | 2462 | -10.823 | 8 | PASS |
| ☒802.11g | 1 | 2412 | -12.336 | 8 | PASS |
| | 6 | 2437 | -12.707 | 8 | PASS |
| | 11 | 2462 | -12.047 | 8 | PASS |
| ☒802.11n (HT20) | 1 | 2412 | -12.507 | 8 | PASS |
| | 6 | 2437 | -12.361 | 8 | PASS |
| | 11 | 2462 | -11.052 | 8 | PASS |
| ☒802.11n (HT40) | 3 | 2422 | -14.820 | 8 | PASS |
| | 6 | 2437 | -16.637 | 8 | PASS |
| | 9 | 2452 | -16.081 | 8 | PASS |

Temperature : 28°C Humidity : 65 %
Antenna: A+B Test By: King Kong

| Operation Mode | Channel Number | Channel Frequency (MHz) | Measurement Level (dBm/3kHz) | Limit (dBm/3kHz) | Verdict |
|-----------------|----------------|-------------------------|------------------------------|------------------|---------|
| ☒802.11n (HT20) | 1 | 2412 | -9.770 | 8 | PASS |
| | 6 | 2437 | -9.809 | 8 | PASS |
| | 11 | 2462 | -9.291 | 8 | PASS |
| ☒802.11n (HT40) | 3 | 2422 | -12.579 | 8 | PASS |
| | 6 | 2437 | -13.630 | 8 | PASS |
| | 9 | 2452 | -13.161 | 8 | PASS |

For Antenna A

Test Model

Power Spectral Density
802.11b
Channel 1: 2412MHz



Test Model

Power Spectral Density
802.11b
Channel 6: 2437MHz



Test Model

Power Spectral Density
802.11b
Channel 11: 2462MHz



Test Model Power Spectral Density
802.11g
Channel 1: 2412MHz

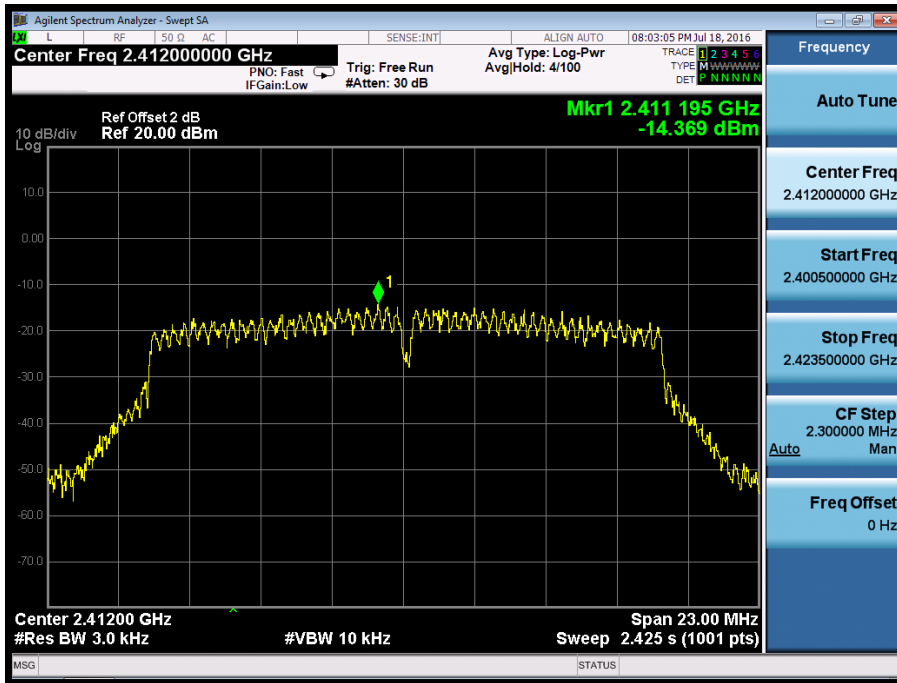

Test Model Power Spectral Density
802.11g
Channel 6: 2437MHz

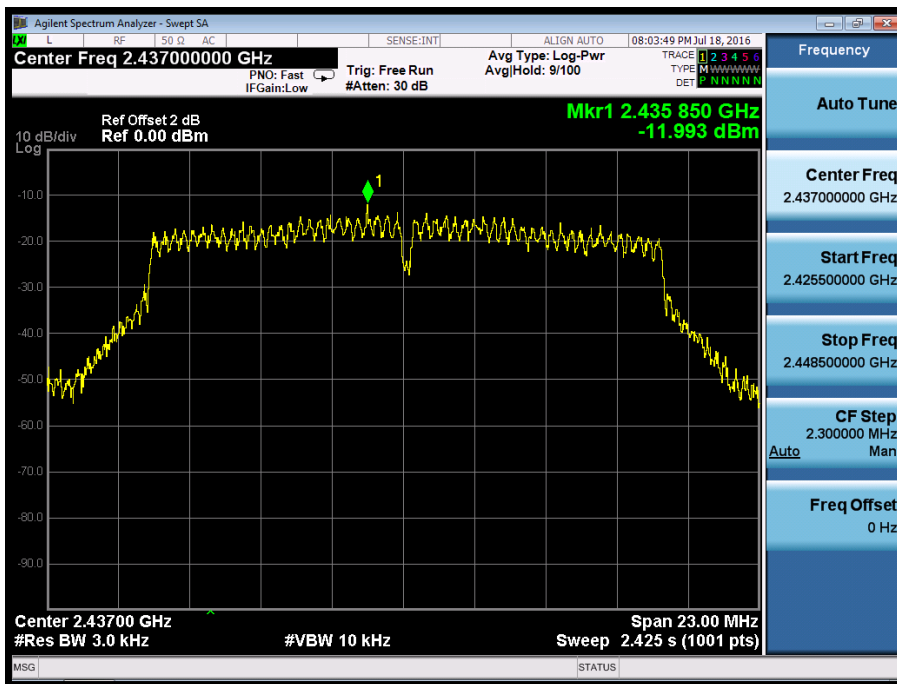

Test Model Power Spectral Density
802.11g
Channel 11: 2462MHz

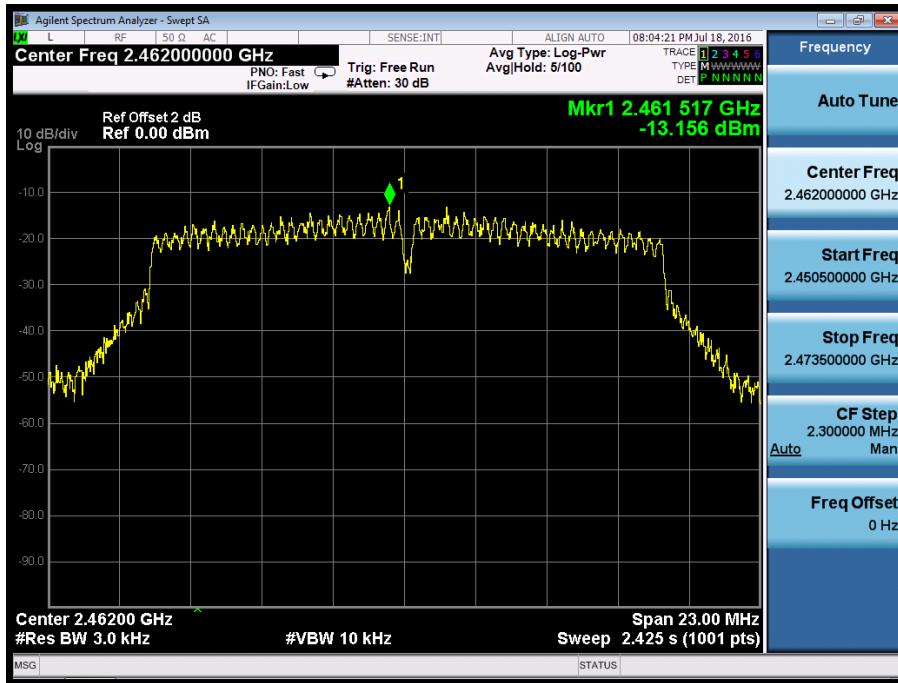

Test Model Power Spectral Density
802.11n (HT20)
Channel 1: 2412MHz

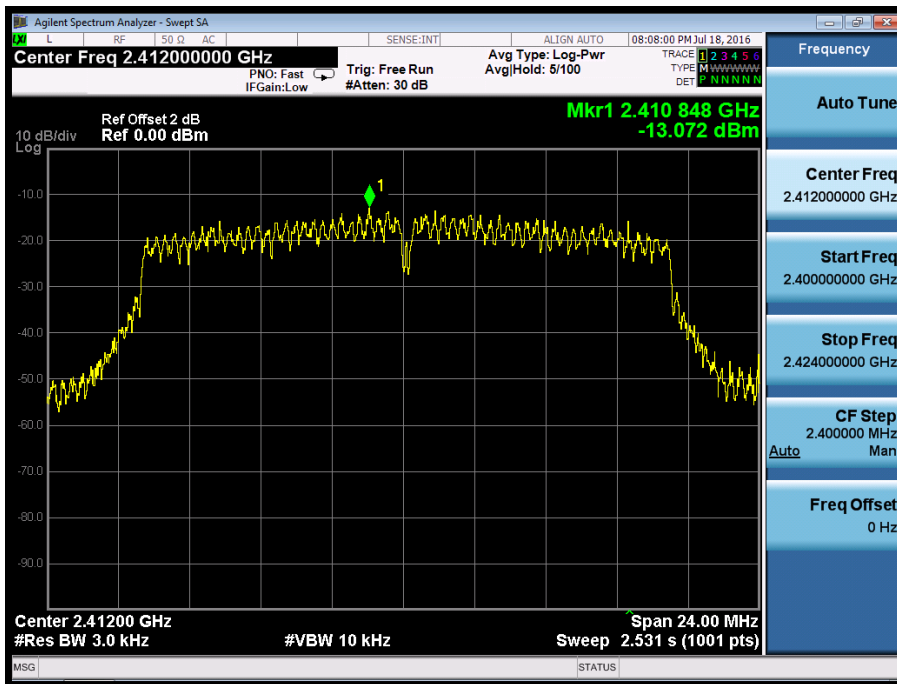

Test Model Power Spectral Density
802.11n (HT20)
Channel 6: 2437MHz

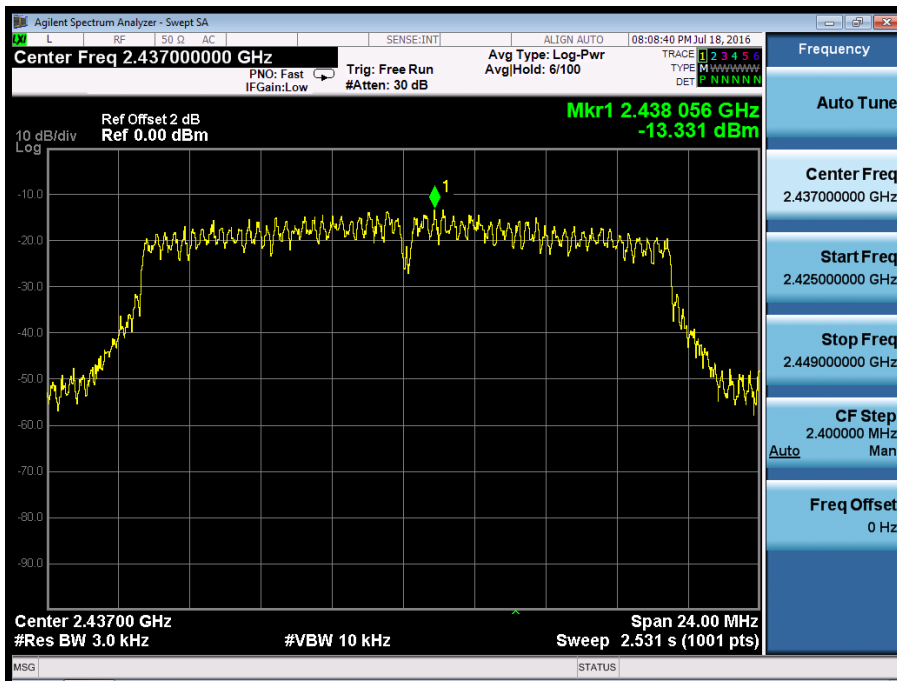

Test Model

Power Spectral Density
802.11n (HT20)
Channel 11: 2462MHz

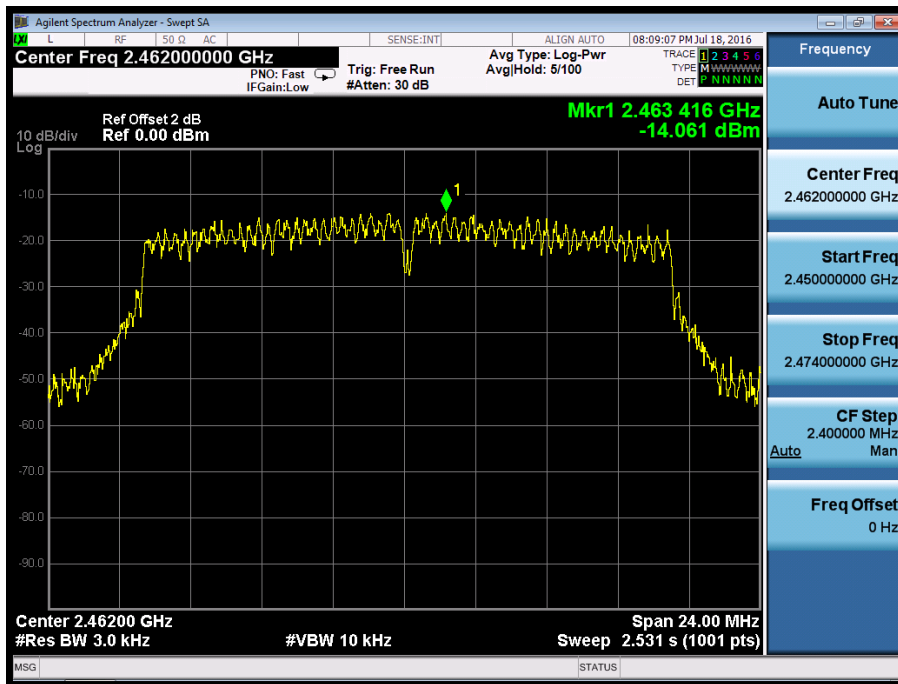

Test Model

Power Spectral Density
802.11n (HT40)
Channel 1: 2422MHz

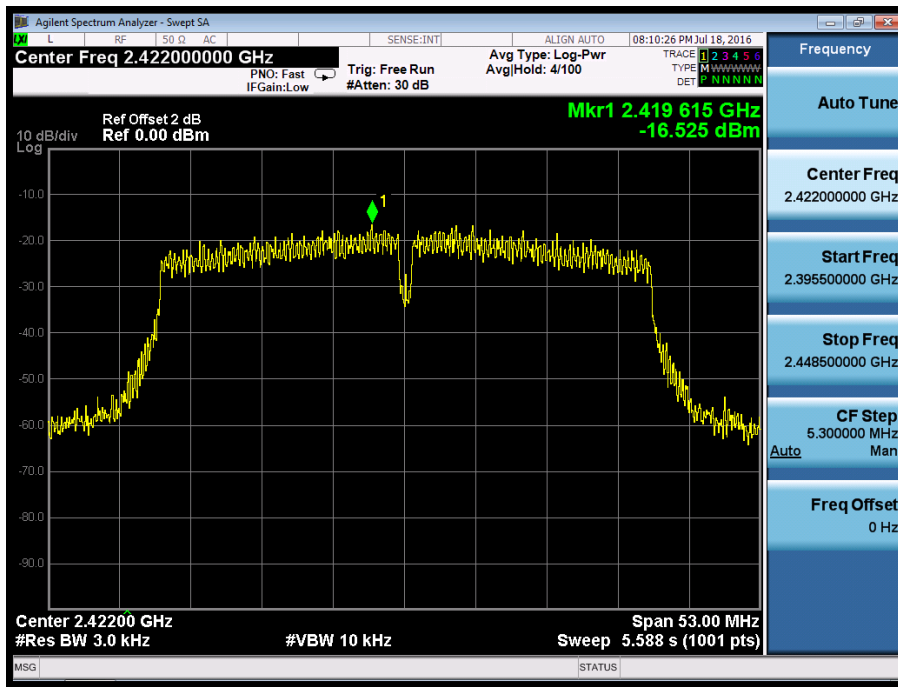

Test Model

Power Spectral Density
802.11n (HT40)
Channel 6: 2437MHz

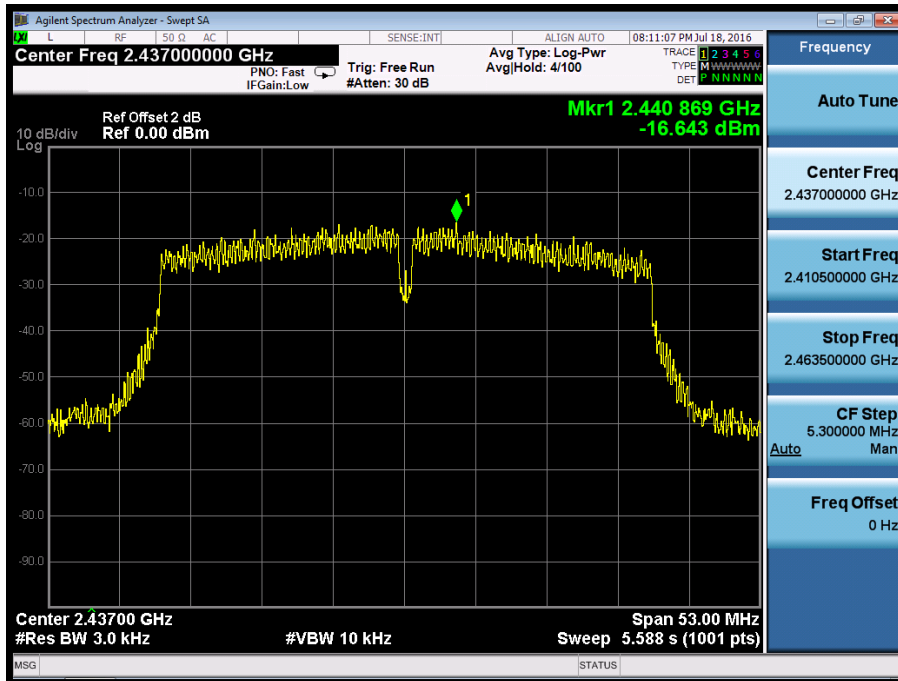

Test Model

Power Spectral Density
802.11n (HT40)
Channel 11: 2452MHz

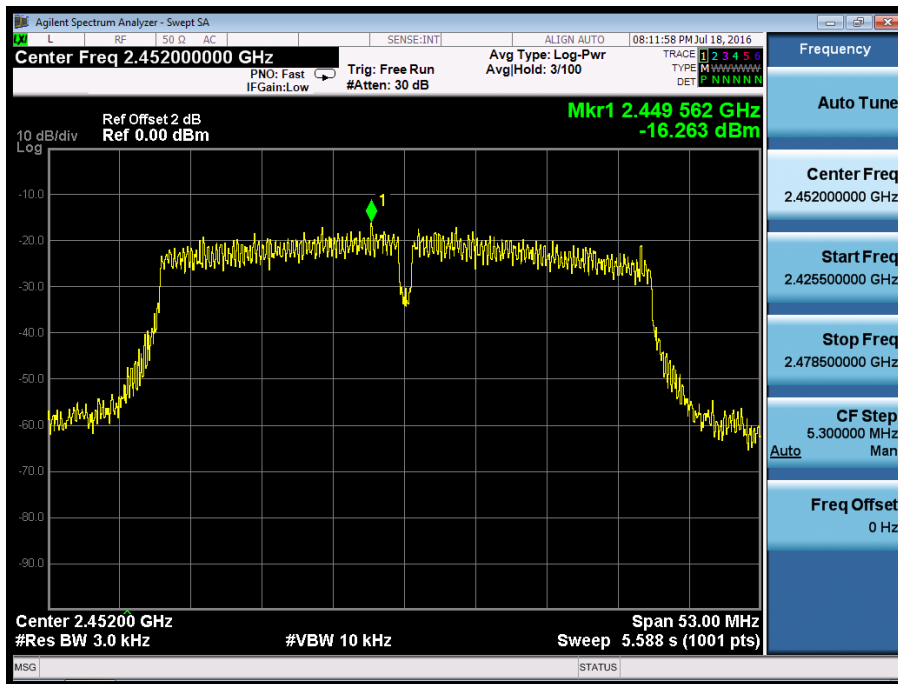

For Antenna B

Test Model

Power Spectral Density
802.11b
Channel 1: 2412MHz



Test Model

Power Spectral Density
802.11b
Channel 6: 2437MHz



Test Model

Power Spectral Density
802.11b
Channel 11: 2462MHz



Test Model

Power Spectral Density
802.11g
Channel 1: 2412MHz

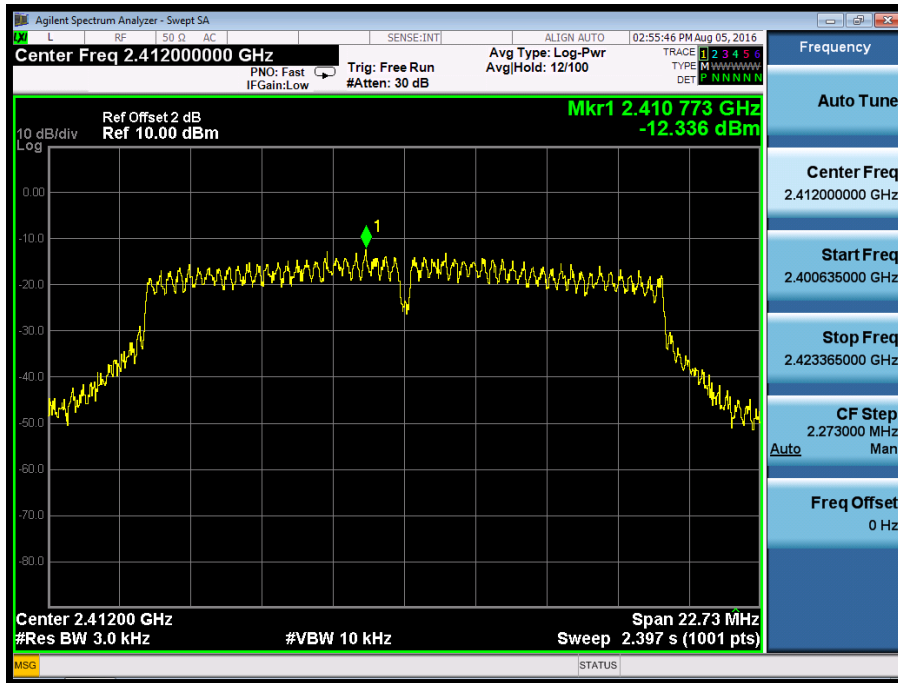

Test Model

Power Spectral Density
802.11g
Channel 6: 2437MHz

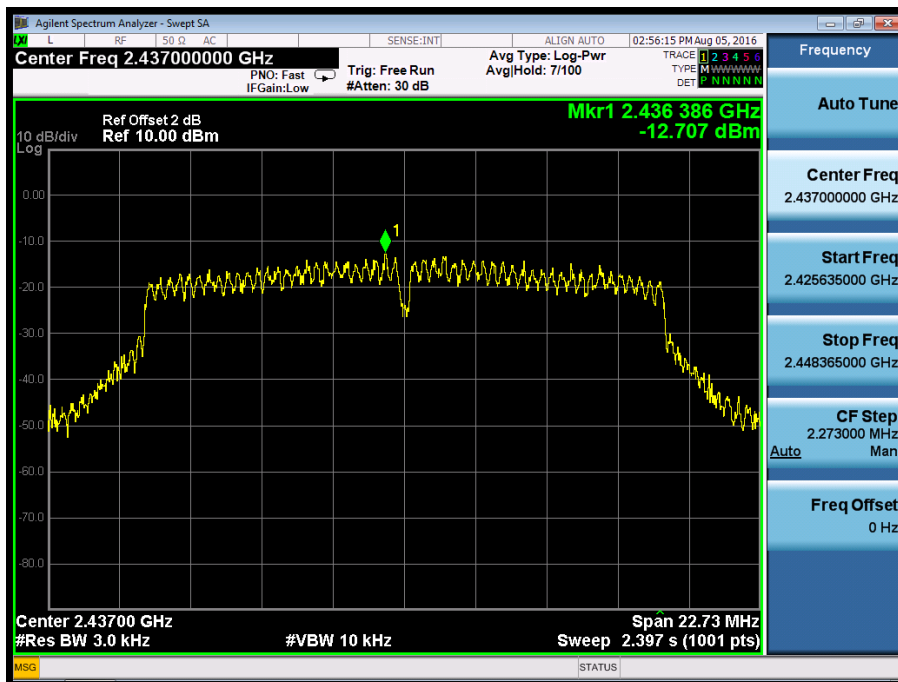

Test Model Power Spectral Density
802.11n (HT20)
Channel 1: 2412MHz

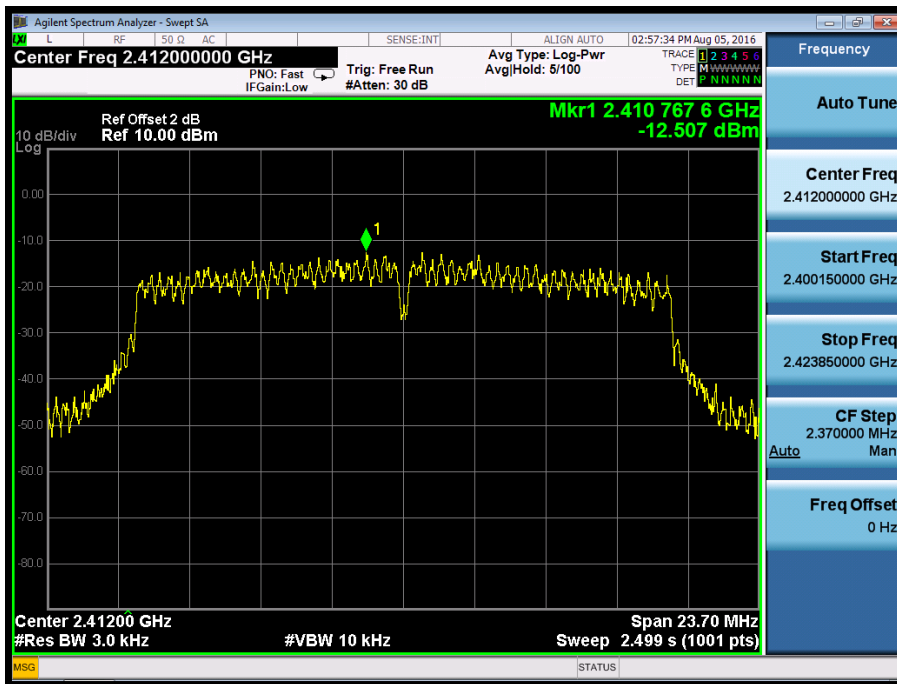

Test Model Power Spectral Density
802.11n (HT20)
Channel 6: 2437MHz

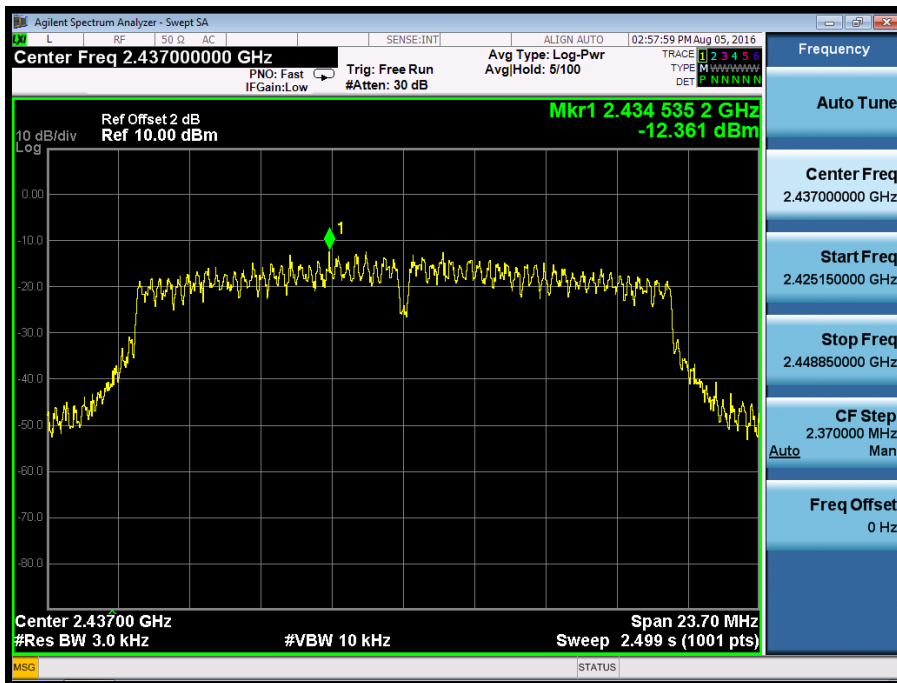

Test Model Power Spectral Density
802.11n (HT20)
Channel 11: 2462MHz

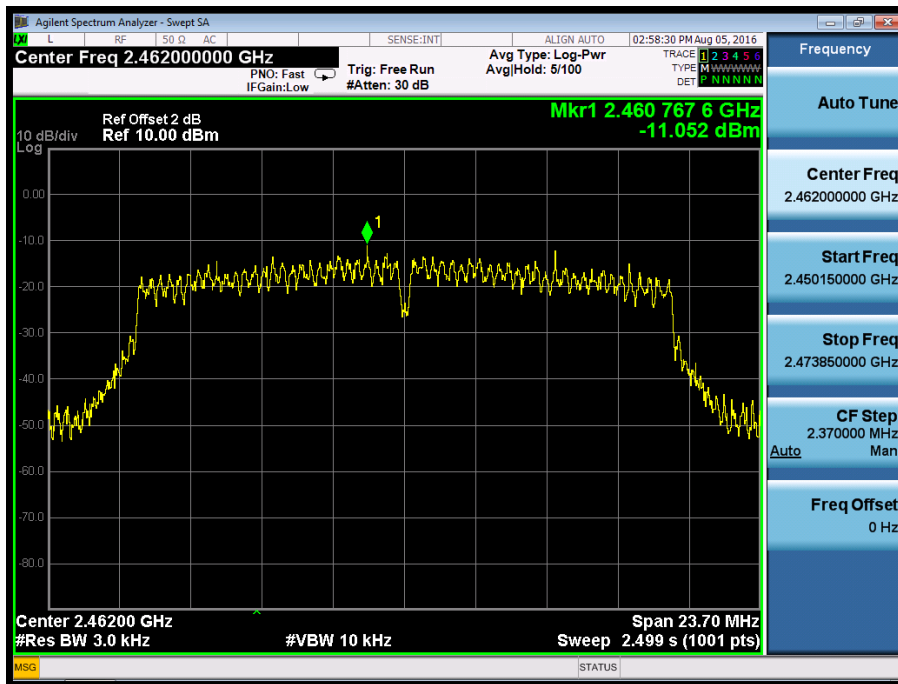

Test Model

Power Spectral Density
802.11n (HT40)
Channel 1: 2422MHz



Test Model

Power Spectral Density
802.11n (HT40)
Channel 6: 2437MHz



Test Model

Power Spectral Density
802.11n (HT40)
Channel 11: 2452MHz

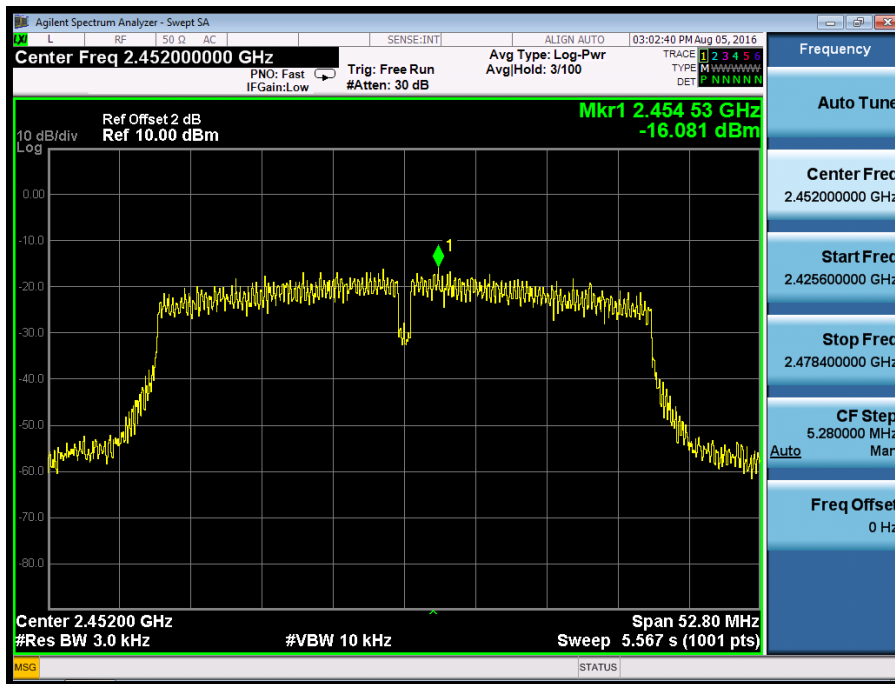

8.4 UNWANTED EMISSIONS IN NON-RESTRICTED FREQUENCY BANDS

8.4.1 Applicable Standard

According to FCC Part 15.247(d) and KDB 558074 DTS 01 Meas. Guidance v03r05

8.4.2 Conformance Limit

According to FCC Part 15.247(d):

In any 100 kHz bandwidth outside the frequency band in which the spread spectrum or digitally modulated intentional radiator is operating, the radio frequency power that is produced by the intentional radiator shall be at least 20 dB below that in the 100 kHz bandwidth within the band that contains the highest level of the desired power, based on either an RF conducted or a radiated measurement, provided the transmitter demonstrates compliance with the peak conducted power limits. If the transmitter complies with the conducted power limits based on the use of RMS averaging over a time interval, as permitted under paragraph (b)(3) of this section, the attenuation required under this paragraph shall be 30 dB instead of 20 dB.

8.4.3 Test Configuration

Test according to clause 7.1 radio frequency test setup 1

8.4.4 Test Procedure

The transmitter output (antenna port) was connected to the spectrum analyzer

■ Reference level measurement

Establish a reference level by using the following procedure:

Set instrument center frequency to DTS channel center frequency.

Set the span to ≥ 1.5 times the DTS bandwidth.

Set the RBW = 100 kHz.

Set the VBW $\geq 3 \times$ RBW.

Set Detector = peak.

Set Sweep time = auto couple.

Set Trace mode = max hold.

Allow trace to fully stabilize.

Use the peak marker function to determine the maximum PSD level.

Note that the channel found to contain the maximum PSD level can be used to establish the reference level.

■ Emission level measurement

Set the center frequency and span to encompass frequency range to be measured.

Set the RBW = 100 kHz.

Set the VBW = 300 kHz.

Set Detector = peak

Sweep time = auto couple.

Trace mode = max hold.

Allow trace to fully stabilize.

Use the peak marker function to determine the maximum amplitude level.

Ensure that the amplitude of all unwanted emissions outside of the authorized frequency band (excluding restricted frequency bands) are attenuated by at least the minimum requirements. Report the three highest emissions relative to the limit.

8.4.5 Test Results

All modes 2.4G 802.11b/g/n with adapter1 and adapter2 have been tested, and the worst result 802.11b with adapter1 for Ant A recorded was report as below:

PSD(Power Spectral Density) RBW=100kHz
 Test Model 802.11b 802.11g 802.11n(HT20) 802.11n(HT40)
 Channel 1: 2412MHz Channel 3: 2422MHz



Unwanted Emissions in non-restricted frequency bands
 Test Model 802.11b 802.11g 802.11n(HT20) 802.11n(HT40)
 Channel 1: 2412MHz Channel 3: 2422MHz

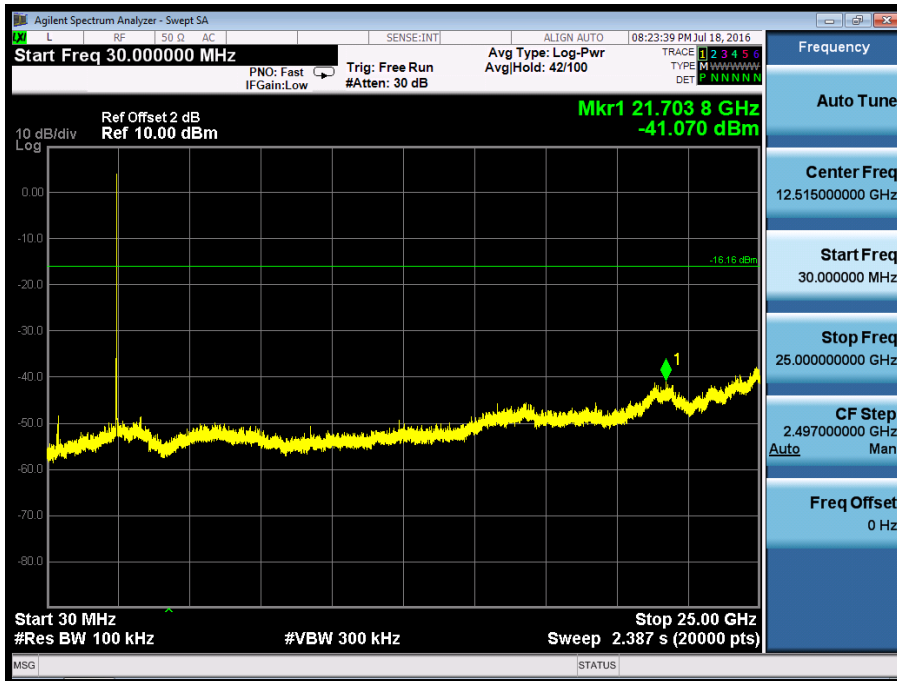

| | | | | | |
|------------|-----------|--|----------------------------------|---|--|
| Test Model | Band edge | <input checked="" type="checkbox"/> 802.11b | <input type="checkbox"/> 802.11g | <input type="checkbox"/> 802.11n(HT20) | <input type="checkbox"/> 802.11n(HT40) |
| | | <input checked="" type="checkbox"/> Channel 1: 2412MHz | | <input type="checkbox"/> Channel 3: 2422MHz | |



Test Model PSD(Power Spectral Density) RBW=100kHz
802.11b 802.11g 802.11n(HT20) 802.11n(HT40)
 Channel 6: 2437MHz



Test Model Unwanted Emissions In Non-Restricted Frequency Bands
802.11b 802.11g 802.11n(HT20) 802.11n(HT40)
 Channel 6: 2437MHz

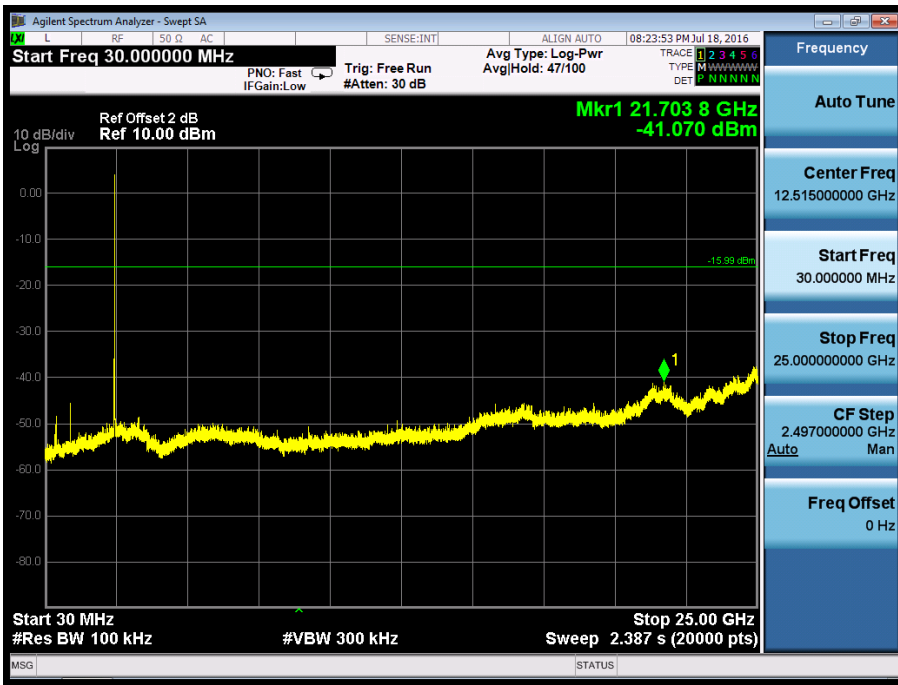

Test Model PSD(Power Spectral Density) RBW=100kHz
802.11b 802.11g 802.11n(HT20) 802.11n(HT40)
Channel 11: 2462MHz Channel 9: 2452MHz



Test Model Unwanted Emissions In Non-Restricted Frequency Bands
802.11b 802.11g 802.11n(HT20) 802.11n(HT40)
Channel 11: 2462MHz Channel 9: 2452MHz



Test Model Band edge

802.11b 802.11g 802.11n(HT20) 802.11n(HT40)

Channel 11: 2462MHz Channel 9: 2452MHz



8.5 RADIATED SPURIOUS EMISSION

8.5.1 Applicable Standard

According to FCC Part 15.247(d) and 15.209 and KDB 558074 DTS 01 Meas. Guidance v03r05

8.5.2 Conformance Limit

According to FCC Part 15.247(d): radiated emissions which fall in the restricted bands, as defined in §15.205(a), must also comply with the radiated emission limits specified in §15.209(a) (see §15.205(c)).

According to FCC Part 15.205, Restricted bands

| MHz | MHz | MHz | GHz |
|-------------------|---------------------|---------------|-------------|
| 0.090-0.110 | 16.42-16.423 | 399.9-410 | 4.5-5.15 |
| 10.495-0.505 | 16.69475-16.69525 | 608-614 | 5.35-5.46 |
| 2.1735-2.1905 | 16.80425-16.80475 | 960-1240 | 7.25-7.75 |
| 4.125-4.128 | 25.5-25.67 | 1300-1427 | 8.025-8.5 |
| 4.17725-4.17775 | 37.5-38.25 | 1435-1626.5 | 9.0-9.2 |
| 4.20725-4.20775 | 73-74.6 | 1645.5-1646.5 | 9.3-9.5 |
| 6.215-6.218 | 74.8-75.2 | 1660-1710 | 10.6-12.7 |
| 6.26775-6.26825 | 123-138 | 2200-2300 | 14.47-14.5 |
| 8.291-8.294 | 149.9-150.05 | 2310-2390 | 15.35-16.2 |
| 8.362-8.366 | 156.52475-156.52525 | 2483.5-2500 | 17.7-21.4 |
| 8.37625-8.38675 | 156.7-156.9 | 2690-2900 | 22.01-23.12 |
| 8.41425-8.41475 | 162.0125-167.17 | 3260-3267 | 23.6-24.0 |
| 12.29-12.293 | 167.72-173.2 | 3332-3339 | 31.2-31.8 |
| 12.51975-12.52025 | 240-285 | 3345.8-3358 | 36.43-36.5 |
| 12.57675-12.57725 | 322-335.4 | 3600-4400 | (2) |
| 13.36-13.41 | | | |

According to FCC Part 15.205, the level of any transmitter spurious emission in Restricted bands shall not exceed the level of the emission specified in the following table

| Restricted Frequency(MHz) | Field Strength ($\mu\text{V}/\text{m}$) | Field Strength ($\text{dB}\mu\text{V}/\text{m}$) | Measurement Distance |
|---------------------------|---|--|----------------------|
| 0.009-0.490 | 2400/F(KHz) | 20 log (uV/m) | 300 |
| 0.490-1.705 | 2400/F(KHz) | 20 log (uV/m) | 30 |
| 1.705-30 | 30 | 29.5 | 30 |
| 30-88 | 100 | 40 | 3 |
| 88-216 | 150 | 43.5 | 3 |
| 216-960 | 200 | 46 | 3 |
| Above 960 | 500 | 54 | 3 |

Remark :1. Emission level in $\text{dB}\mu\text{V}/\text{m}=20 \log (\text{uV}/\text{m})$

2. Measurement was performed at an antenna to the closed point of EUT distance of meters.

3. Distance extrapolation factor $=40\log(\text{Specific distance}/\text{test distance})(\text{dB})$;

Limit line= $\text{Specific limits}(\text{dB}\mu\text{V}) + \text{distance extrapolation factor}$.

for the frequency ranges below 30 MHz, a narrower RBW is used for these ranges but the measured value should add a RBW correction factor (RBWCF) where $\text{RBWCF}[\text{dB}]=10*\lg(100[\text{kHz}]/\text{narrower RBW}[\text{kHz}])$. , the narrower RBW is 1 kHz and RBWCF is 20 dB for the frequency 9 kHz to 150 kHz, and the narrower RBW is 10 kHz and RBWCF is 10 dB for the frequency 150 kHz to 30 MHz.

8.5.3 Test Configuration

Test according to clause 7.2 radio frequency test setup 2

8.5.4 Test Procedure

This test is required for any spurious emission that falls in a Restricted Band, as defined in Section 15.205. It must be performed with the highest gain of each type of antenna proposed for use with the EUT. Use the following spectrum analyzer settings:

For Above 1GHz:

The EUT was placed on a turn table which is 1.5m above ground plane.

Maximum procedure was performed on the highest emissions to ensure EUT compliance.

Span = wide enough to fully capture the emission being measured

RBW = 1 MHz

VBW \geq RBW

Sweep = auto

Detector function = peak

Trace = max hold

For Below 1GHz:

The EUT was placed on a turn table which is 0.8m above ground plane.

Maximum procedure was performed on the highest emissions to ensure EUT compliance.

Span = wide enough to fully capture the emission being measured

RBW = 100 kHz for

VBW \geq RBW

Sweep = auto

Detector function = peak

Trace = max hold

For Below 30MHz:

The EUT was placed on a turn table which is 0.8m above ground plane.

Maximum procedure was performed on the highest emissions to ensure EUT compliance.

Span = wide enough to fully capture the emission being measured

RBW = 9kHz

VBW \geq RBW

Sweep = auto

Detector function = peak

Trace = max hold

For Below 150KHz:

The EUT was placed on a turn table which is 0.8m above ground plane.

Maximum procedure was performed on the highest emissions to ensure EUT compliance.

Span = wide enough to fully capture the emission being measured

RBW = 200Hz

VBW \geq RBW

Sweep = auto

Detector function = peak

Trace = max hold

Follow the guidelines in ANSI C63.10-2013 with respect to maximizing the emission by rotating the EUT, measuring the emission while the EUT is situated in three orthogonal planes (if appropriate), adjusting the measurement antenna height and polarization, etc. A pre-amp and a high pass filter are required for this test, in order to provide the measuring system with sufficient sensitivity. Allow the trace to stabilize. The peak reading of the emission, after being corrected by the antenna factor, cable loss, pre-amp gain, etc., is the peak field strength, which must comply with the limit specified in Section 15.35(b). Submit this data.

Now set the VBW to 10 Hz, while maintaining all of the other instrument settings. This peak level, once corrected, must comply with the limit specified in Section 15.209. If the dwell time per channel of the hopping signal is less than 100 ms, then the reading obtained with the 10 Hz VBW may be further adjusted by a "duty cycle correction factor", derived from $20\log(\text{dwell time}/100 \text{ ms})$, in an effort to demonstrate compliance with the 15.209 limit. Submit this data.

Repeat above procedures until all frequency measured was complete.

8.5.5 Test Results

■ Spurious Emission below 30MHz (9KHz to 30MHz)

| | | | |
|--------------|---------|------------|---------------|
| Temperature: | 24°C | Test Date: | July 18, 2016 |
| Humidity: | 53 % | Test By: | King Kong |
| Test mode: | TX Mode | | |

| Freq. (MHz) | Ant.Pol. H/V | Emission Level(dBuV/m) | | Limit 3m(dBuV/m) | | Over(dB) | |
|----------------|-----------------|---------------------------|----|------------------|----|----------|----|
| | | PK | AV | PK | AV | PK | AV |
| -- | -- | -- | -- | -- | -- | -- | -- |

Note: the amplitude of spurious emission that is attenuated by more than 20dB below the permissible limit has no need to be reported.

Distance extrapolation factor = $40\log(\text{Specific distance}/ \text{test distance})$ (dB);

Limit line=Specific limits(dBuV) + distance extrapolation factor

■ Spurious Emission Above 1GHz (1GHz to 25GHz)

All modes 2.4G 802.11b/g/n with adapter1 and adapter2 have been tested, and the worst result 802.11b with adapter1 recorded was report as below:

| | | | |
|---------------|---------|-------------|--------------------|
| Temperature : | 28°C | Test Date : | July 18, 2016 |
| Humidity : | 65 % | Test By: | King Kong |
| Test mode: | 802.11b | Frequency: | Channel 1: 2412MHz |

| Freq. (MHz) | Ant.Pol. H/V | Emission Level(dBuV/m) | | Limit 3m(dBuV/m) | | Over(dB) | |
|-------------|--------------|------------------------|-------|------------------|-------|----------|--------|
| | | PK | AV | PK | AV | PK | AV |
| 4824.65 | V | 50.69 | 43.64 | 74.00 | 54.00 | -23.31 | -10.36 |
| 7237.27 | V | 48.24 | 41.78 | 74.00 | 54.00 | -25.76 | -12.22 |
| 9649.69 | V | 48.02 | 40.78 | 74.00 | 54.00 | -25.98 | -13.22 |
| -- | -- | -- | -- | -- | -- | -- | -- |
| -- | -- | -- | -- | -- | -- | -- | -- |
| -- | -- | -- | -- | -- | -- | -- | -- |
| 4824.53 | H | 51.22 | 43.75 | 74.00 | 54.00 | -22.78 | -10.25 |
| 7236.63 | H | 47.92 | 41.07 | 74.00 | 54.00 | -26.08 | -12.93 |
| 9649.22 | H | 48.47 | 40.44 | 74.00 | 54.00 | -25.53 | -13.56 |

| | | | |
|---------------|---------|-------------|--------------------|
| Temperature : | 28°C | Test Date : | July 18, 2016 |
| Humidity : | 65 % | Test By: | King Kong |
| Test mode: | 802.11b | Frequency: | Channel 6: 2437MHz |

| Freq. (MHz) | Ant.Pol. H/V | Emission Level(dBuV/m) | | Limit 3m(dBuV/m) | | Over(dB) | |
|-------------|--------------|------------------------|-------|------------------|-------|----------|--------|
| | | PK | AV | PK | AV | PK | AV |
| 4875.13 | V | 50.01 | 44.34 | 74.00 | 54.00 | -23.99 | -9.66 |
| 7311.15 | V | 47.73 | 42.6 | 74.00 | 54.00 | -26.27 | -11.40 |
| 9748.91 | V | 48.61 | 39.97 | 74.00 | 54.00 | -25.39 | -14.03 |
| -- | -- | -- | -- | -- | -- | -- | -- |
| -- | -- | -- | -- | -- | -- | -- | -- |
| -- | -- | -- | -- | -- | -- | -- | -- |
| 4874.37 | H | 50.83 | 42.91 | 74.00 | 54.00 | -23.17 | -11.09 |
| 7312.99 | H | 47.95 | 41.46 | 74.00 | 54.00 | -26.05 | -12.54 |
| 9748.71 | H | 48.5 | 40.88 | 74.00 | 54.00 | -25.50 | -13.12 |

| | | | |
|---------------|---------|-------------|---------------------|
| Temperature : | 28°C | Test Date : | July 18, 2016 |
| Humidity : | 65 % | Test By: | King Kong |
| Test mode: | 802.11b | Frequency: | Channel 11: 2462MHz |

| Freq. (MHz) | Ant.Pol. H/V | Emission Level(dBuV/m) | | Limit 3m(dBuV/m) | | Over(dB) | |
|-------------|--------------|------------------------|-------|------------------|-------|----------|--------|
| | | PK | AV | PK | AV | PK | AV |
| 4924.66 | V | 51.14 | 41.82 | 74.00 | 54.00 | -22.86 | -12.18 |
| 7386.24 | V | 46.77 | 41.29 | 74.00 | 54.00 | -27.23 | -12.71 |
| 9849.97 | V | 48.75 | 42.09 | 74.00 | 54.00 | -25.25 | -11.91 |
| -- | -- | -- | -- | -- | -- | -- | -- |
| -- | -- | -- | -- | -- | -- | -- | -- |
| -- | -- | -- | -- | -- | -- | -- | -- |
| 4925.46 | H | 51.35 | 43.03 | 74.00 | 54.00 | -22.65 | -10.97 |
| 7387.4 | H | 47.9 | 40.82 | 74.00 | 54.00 | -26.10 | -13.18 |
| 9849.38 | H | 49.27 | 39.22 | 74.00 | 54.00 | -24.73 | -14.78 |

- Note:**
- (1) All Readings are Peak Value (VBW=3MHz) and Peak Value (VBW=10Hz).
 - (2) Emission Level= Reading Level+Probe Factor +Cable Loss.
 - (3) Data of measurement within this frequency range shown "--" in the table above means the reading of emissions are attenuated more than 20dB below the permissible limits or the field strength is too small to be measured.

■ Spurious Emission in Restricted Band 2310-2390MHz and 2483.5-2500MHz
 All modes 2.4G 802.11b/g/n with adapter1 and adapter2 have been tested, and the worst result 802.11nHT40 MIMO with adapter1 recorded was report as below:

| | | | |
|---------------|-------------|-------------|--------------------|
| Temperature : | 28°C | Test Date : | July 18, 2016 |
| Humidity : | 65 % | Test By: | King Kong |
| Test mode: | 802.11nHT40 | Frequency: | Channel 3: 2422MHz |

| Frequency (MHz) | Polarity | PK(dBuV/m) (VBW=3MHz) | Limit 3m (dBuV/m) | AV(dBuV/m) (VBW=10Hz) | Limit 3m (dBuV/m) |
|-----------------|----------|-----------------------|-------------------|-----------------------|-------------------|
| 2387.20 | H | 67.35 | 74.00 | 48.32 | 54.00 |
| 2389.44 | H | 66.89 | 74.00 | 47.09 | 54.00 |
| 2387.52 | V | 66.91 | 74.00 | 47.38 | 54.00 |
| 2389.44 | V | 37.34 | 74.00 | 48.75 | 54.00 |

| | | | |
|---------------|-------------|-------------|--------------------|
| Temperature : | 28°C | Test Date : | July 18, 2016 |
| Humidity : | 65 % | Test By: | King Kong |
| Test mode: | 802.11nHT40 | Frequency: | Channel 9: 2452MHz |

| Frequency (MHz) | Polarity | PK(dBuV/m) (VBW=3MHz) | Limit 3m (dBuV/m) | AV(dBuV/m) (VBW=10Hz) | Limit 3m (dBuV/m) |
|-----------------|----------|-----------------------|-------------------|-----------------------|-------------------|
| 2483.65 | H | 65.15 | 74.00 | 48.95 | 54.00 |
| 2484.24 | H | 48.95 | 74.00 | 47.57 | 54.00 |
| 2484.42 | V | 66.63 | 74.00 | 48.95 | 54.00 |
| 2484.42 | V | 66.80 | 74.00 | 49.37 | 54.00 |

- Note:** (1) All Readings are Peak Value (VBW=3MHz) and Peak Value (VBW=10Hz).
 (2) Emission Level= Reading Level+Probe Factor +Cable Loss.
 (3) Data of measurement within this frequency range shown “ -- ” in the table above means the reading of emissions are attenuated more than 20dB below the permissible limits or the field strength is too small to be measured.

Spurious Emission in Restricted Band 2310-2390MHz

Test Model 802.11b 802.11g 802.11n(HT20) 802.11n(HT40)

Channel 1: 2412MHz Channel 3: 2422MHz Polarity: H

VBW=3MHz Test By: King Kong

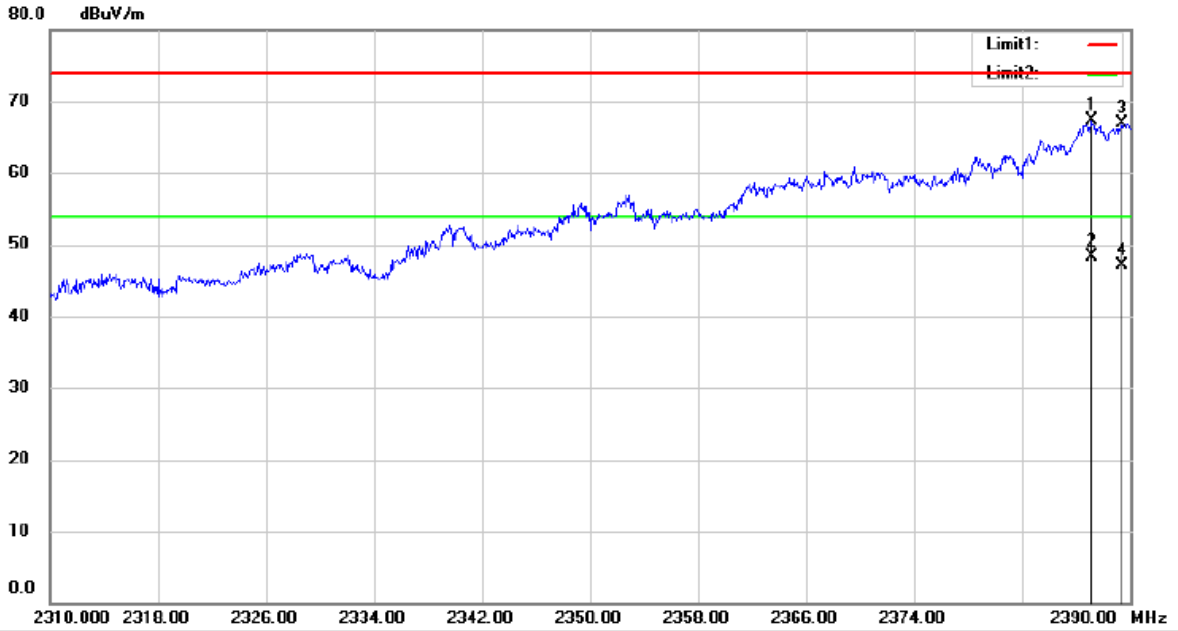

Site 3m Chamber #3 Polarization: **Horizontal** Temperature: 24 C

Limit: (RE)FCC PART 15 CLASS B Power: AC 120V/60Hz Humidity: 53 %

Spurious Emission in Restricted Band 2310-2390MHz

Test Model 802.11b 802.11g 802.11n(HT20) 802.11n(HT40)

Channel 1: 2412MHz Channel 3: 2422MHz Polarity: V

VBW=3MHz Test By: King Kong

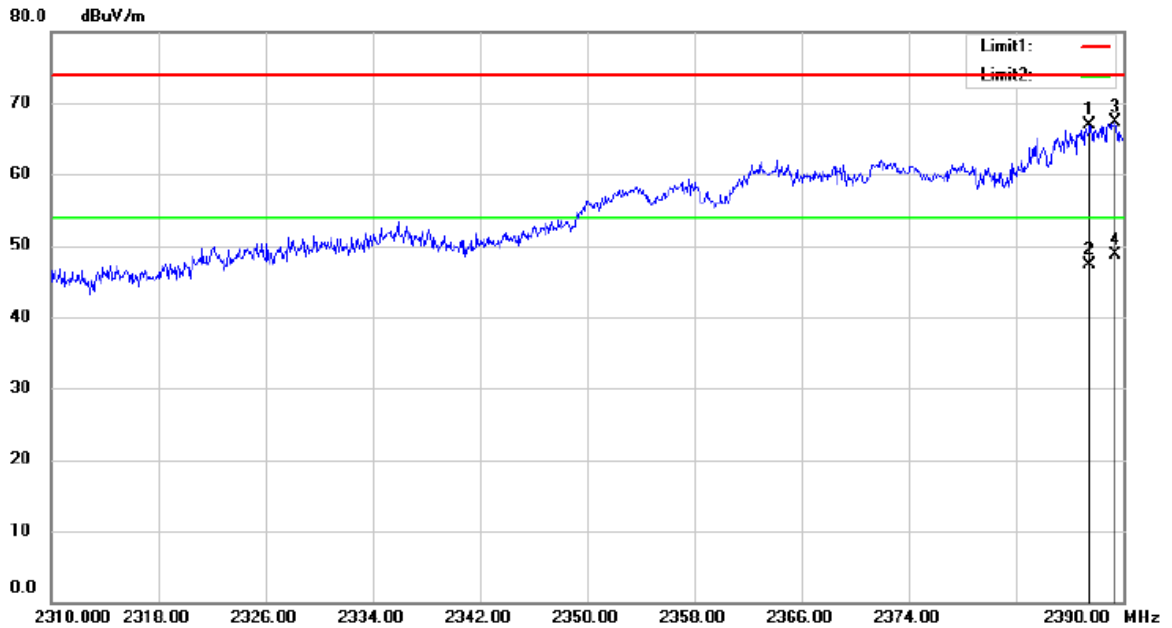

Site 3m Chamber #3 Polarization: **Vertical** Temperature: 24 C

Limit: (RE)FCC PART 15 CLASS B Power: AC 120V/60Hz Humidity: 53 %

Spurious Emission in Restricted Band 2483.5-2500MHz
 Test Model 802.11b 802.11g 802.11n(HT20) 802.11n(HT40)
 Channel 11: 2462MHz Channel 9: 2452MHz Polarity: H
 VBW=3MHz Test By: King Kong

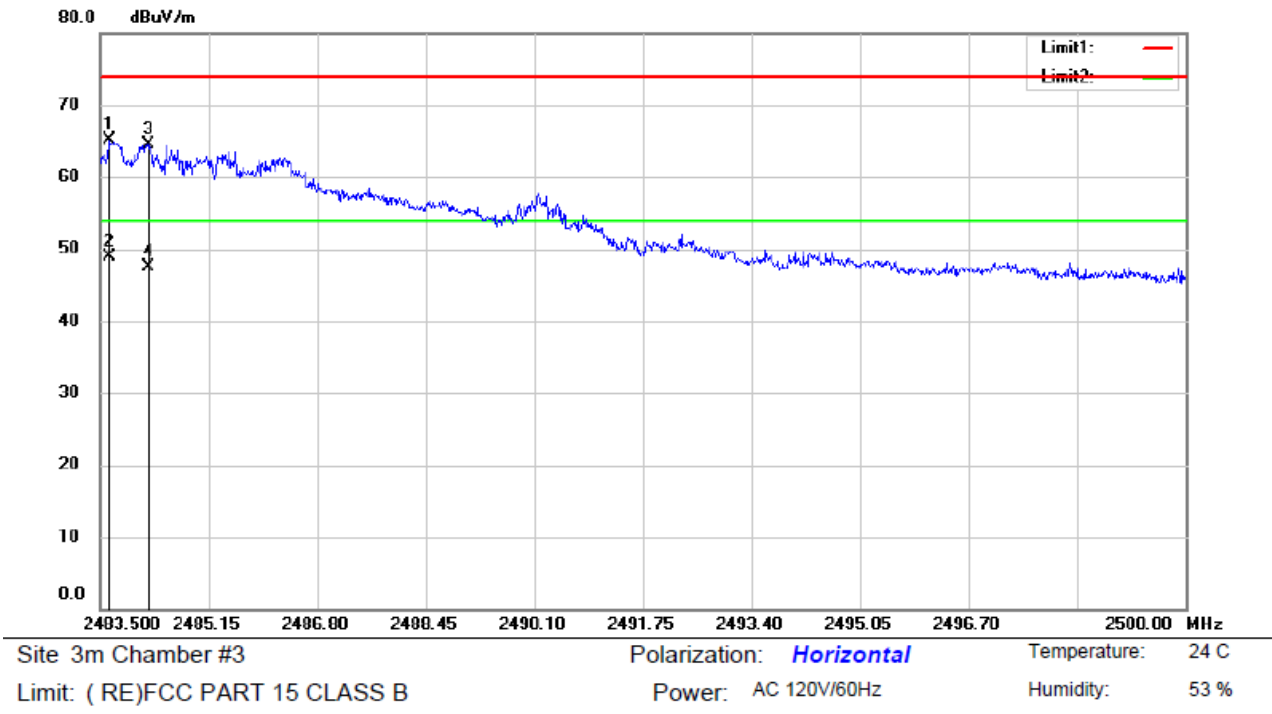

Spurious Emission in Restricted Band 2483.5-2500MHz
 Test Model 802.11b 802.11g 802.11n(HT20) 802.11n(HT40)
Channel 11: 2462MHz Channel 9: 2452MHz Polarity: V
 VBW=3MHz Test By: King Kong

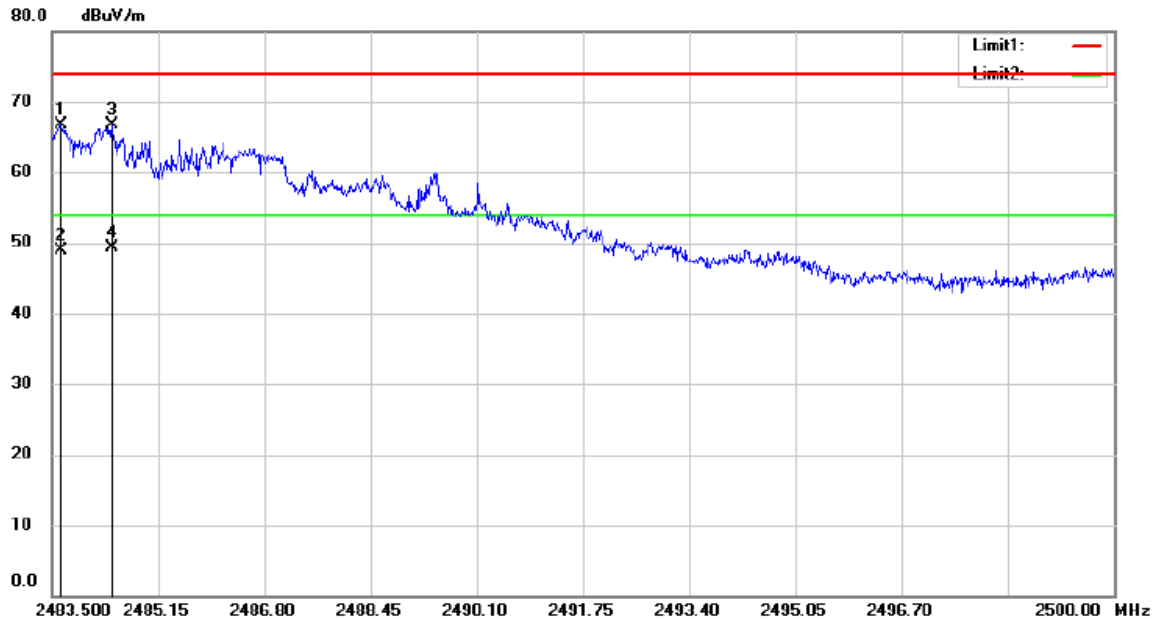

Site 3m Chamber #3 Polarization: *Vertical* Temperature: 24 C
 Limit: (RE)FCC PART 15 CLASS B Power: AC 120V/60Hz Humidity: 53 %

■ Spurious Emission below 1GHz (30MHz to 1GHz)

All modes 2.4G 802.11b/g/n have been tested, and the worst result 802.11b recorded was report as below:

For adapter1

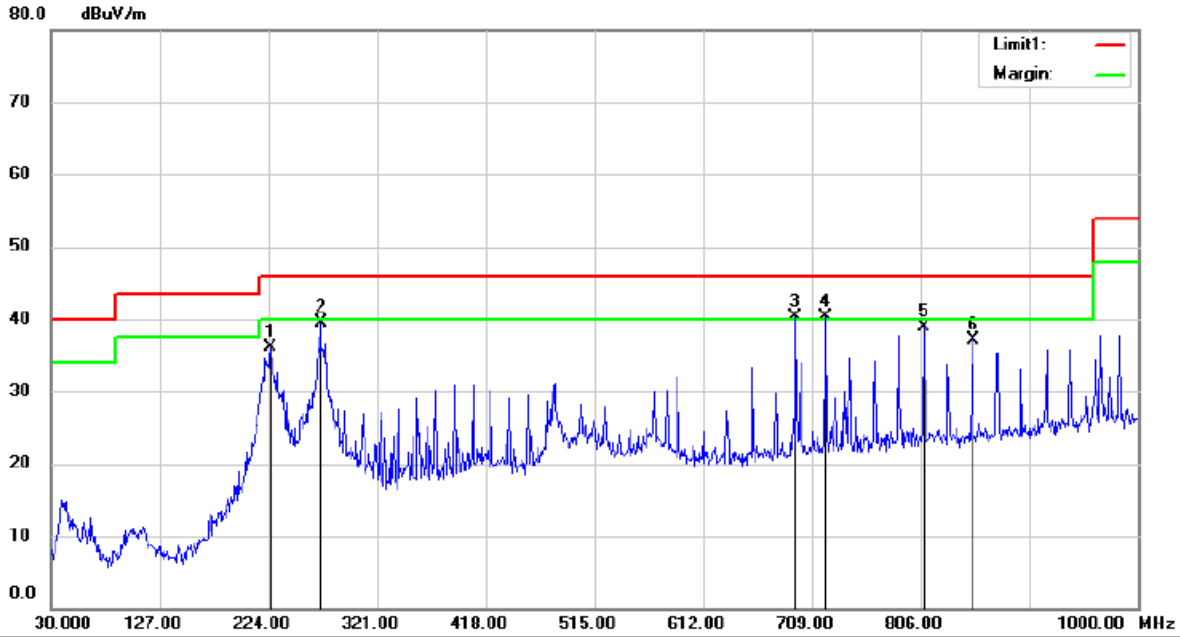

Site 3m Chamber #3 Polarization: **Horizontal** Temperature: 24 C
 Limit: (RE)FCC PART 15 CLASS B Power: AC 120V/60Hz Humidity: 53 %
 Mode:TX LOW
 Note: ADAPTER:S12B22-120A100-C4

| No. | Mk. | Freq. MHz | Reading Level dBuV | Correct Factor dB | Measure- ment dBuV/m | Limit dBuV/m | Over dB | Antenna Height cm | Table Degree degree | Comment |
|-----|-----|--------------|--------------------------|-------------------------|----------------------------|-----------------|------------|-------------------------|---------------------------|---------|
| 1 | | 225.9400 | 50.40 | -14.32 | 36.08 | 46.00 | -9.92 | | | QP |
| 2 | | 270.5600 | 52.12 | -12.71 | 39.41 | 46.00 | -6.59 | | | QP |
| 3 | ! | 694.4500 | 44.69 | -4.33 | 40.36 | 46.00 | -5.64 | | | QP |
| 4 | * | 721.6100 | 44.32 | -3.94 | 40.38 | 46.00 | -5.62 | | | QP |
| 5 | | 808.9100 | 41.67 | -2.72 | 38.95 | 46.00 | -7.05 | | | QP |
| 6 | | 852.5600 | 39.35 | -2.15 | 37.20 | 46.00 | -8.80 | | | QP |

*:Maximum data x:Over limit !:over margin

Operator: csl

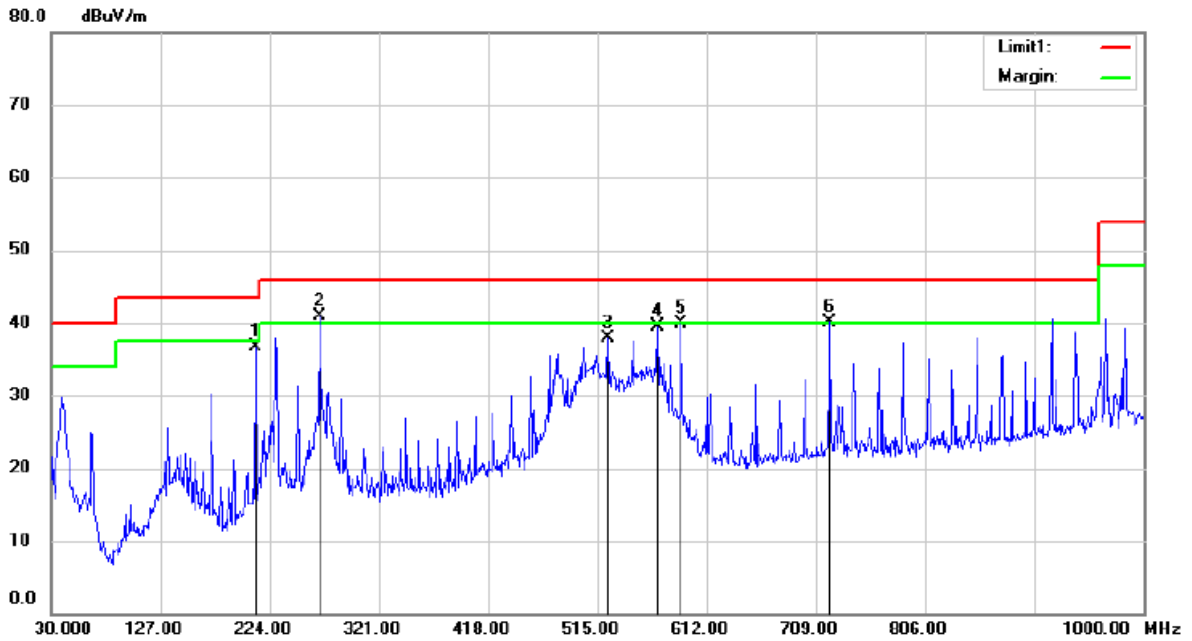

Site 3m Chamber #3 Polarization: **Vertical** Temperature: 24 C
 Limit: (RE)FCC PART 15 CLASS B Power: AC 120V/60Hz Humidity: 53 %
 Mode:TX LOW
 Note: ADAPTER:S12B22-120A100-C4

| No. | Mk. | Freq. | Reading Level | Correct Factor | Measurement | Limit | Over | Antenna Height | Table Degree | |
|-----|-----|----------|---------------|----------------|-------------|--------|-------|----------------|--------------|---------|
| | | MHz | dBuV | dB | dBuV/m | dBuV/m | dB | cm | degree | Comment |
| 1 | | 211.3900 | 51.67 | -14.95 | 36.72 | 43.50 | -6.78 | QP | | |
| 2 | * | 268.6200 | 53.66 | -12.76 | 40.90 | 46.00 | -5.10 | QP | | |
| 3 | | 524.7000 | 45.00 | -7.06 | 37.94 | 46.00 | -8.06 | QP | | |
| 4 | | 568.3500 | 45.79 | -6.35 | 39.44 | 46.00 | -6.56 | QP | | |
| 5 | | 589.6900 | 45.84 | -6.01 | 39.83 | 46.00 | -6.17 | QP | | |
| 6 | ! | 721.6100 | 44.13 | -3.94 | 40.19 | 46.00 | -5.81 | QP | | |

*:Maximum data x:Over limit !:over margin

Operator: csl

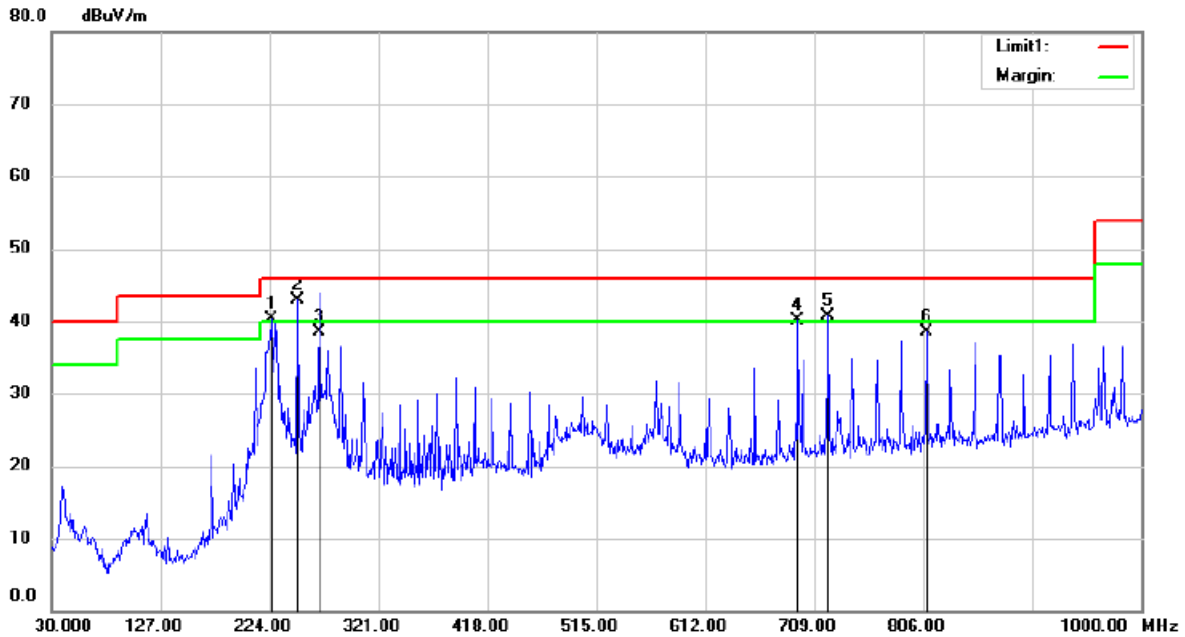

Site: 3m Chamber #3 Polarization: *Horizontal* Temperature: 24 C
 Limit: (RE)FCC PART 15 CLASS B Power: AC 120V/60Hz Humidity: 53 %
 Mode: TX MID
 Note: ADAPTER:S12B22-120A100-C4

| No. | Mk. | Freq. MHz | Reading Level dBuV | Correct Factor dB | Measure- ment dBuV/m | Limit dBuV/m | Over dB | Detector | Antenna Height cm | Table Degree | Comment |
|-----|-----|--------------|--------------------------|-------------------------|----------------------------|-----------------|------------|----------|-------------------------|-----------------|---------|
| 1 | ! | 225.9400 | 54.66 | -14.32 | 40.34 | 46.00 | -5.66 | QP | | | |
| 2 | * | 249.2200 | 56.40 | -13.50 | 42.90 | 46.00 | -3.10 | QP | | | |
| 3 | | 268.6200 | 51.26 | -12.76 | 38.50 | 46.00 | -7.50 | QP | | | |
| 4 | ! | 694.4500 | 44.42 | -4.33 | 40.09 | 46.00 | -5.91 | QP | | | |
| 5 | ! | 721.6100 | 44.59 | -3.94 | 40.65 | 46.00 | -5.35 | QP | | | |
| 6 | | 808.9100 | 41.17 | -2.72 | 38.45 | 46.00 | -7.55 | QP | | | |

*:Maximum data x:Over limit !:over margin

Operator: csl

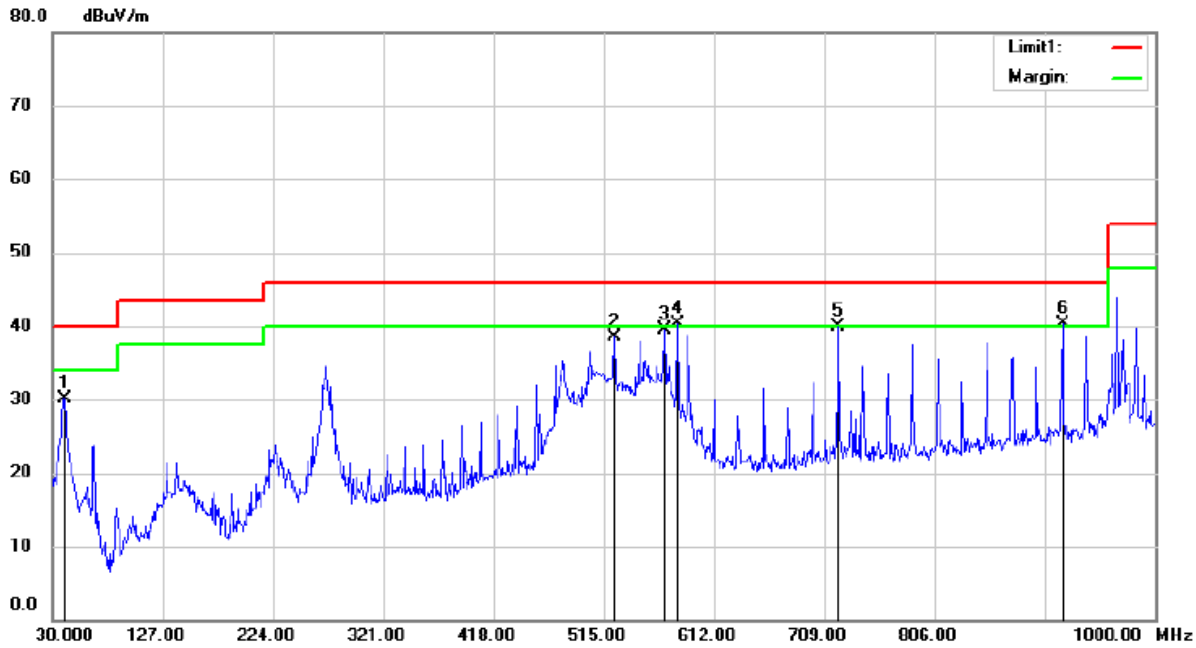

Site 3m Chamber #3 Polarization: *Vertical* Temperature: 24 C
 Limit: (RE)FCC PART 15 CLASS B Power: AC 120V/60Hz Humidity: 53 %
 Mode: TX MID
 Note: ADAPTER:S12B22-120A100-C4

| No. | Mk. | Freq. MHz | Reading Level dBuV | Correct Factor dB | Measure- ment dBuV/m | Limit dBuV/m | Over dB | Detector | Antenna Height cm | Table Degree | Comment |
|-----|-----|--------------|--------------------------|-------------------------|----------------------------|-----------------|------------|----------|-------------------------|-----------------|---------|
| 1 | | 40.6700 | 45.40 | -15.34 | 30.06 | 40.00 | -9.94 | QP | | | |
| 2 | | 524.7000 | 45.47 | -7.06 | 38.41 | 46.00 | -7.59 | QP | | | |
| 3 | | 568.3500 | 45.83 | -6.35 | 39.48 | 46.00 | -6.52 | QP | | | |
| 4 | ! | 579.9900 | 46.54 | -6.17 | 40.37 | 46.00 | -5.63 | QP | | | |
| 5 | | 721.6100 | 43.84 | -3.94 | 39.90 | 46.00 | -6.10 | QP | | | |
| 6 | * | 918.5200 | 41.66 | -1.28 | 40.38 | 46.00 | -5.62 | QP | | | |

*:Maximum data x:Over limit !:over margin

Operator: csl

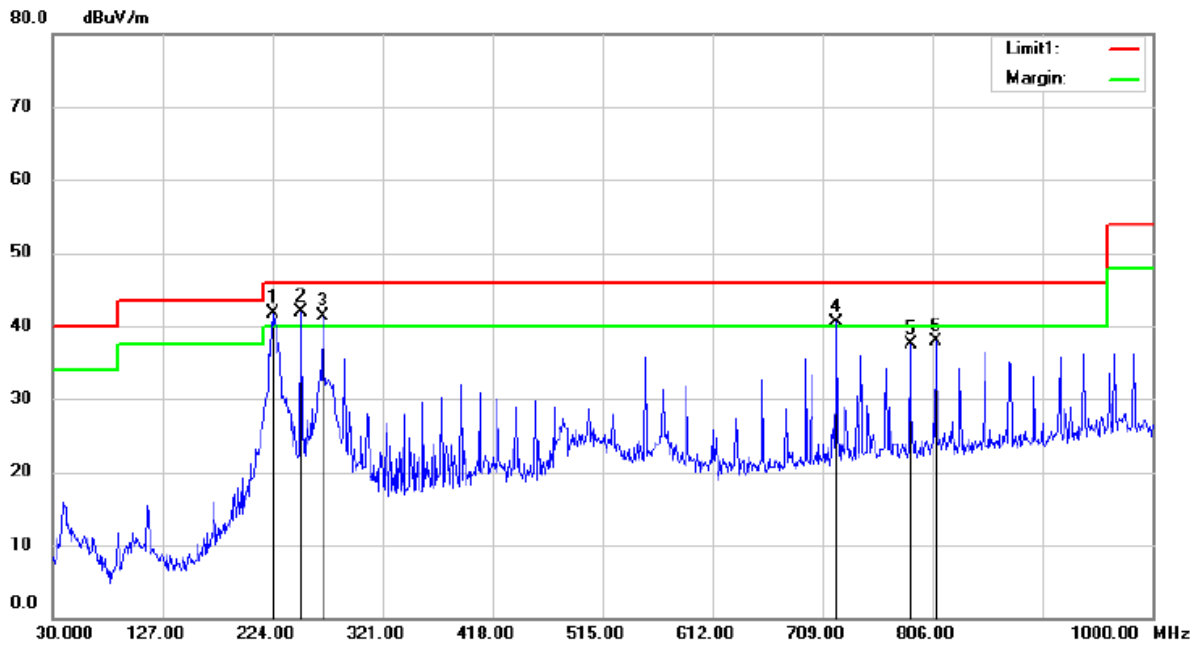

Site 3m Chamber #3 Polarization: *Horizontal* Temperature: 24 C
 Limit: (RE)FCC PART 15 CLASS B Power: AC 120V/60Hz Humidity: 53 %
 Mode:TX HIGH
 Note: ADAPTER:S12B22-120A100-C4

| No. | Mk. | Freq. | Reading Level | Correct Factor | Measurement | Limit | Over | Antenna Height | Table Degree | |
|-----|-----|----------|---------------|----------------|-------------|--------|-------|----------------|--------------|---------|
| | | MHz | dBuV | dB | dBuV/m | dBuV/m | dB | cm | degree | Comment |
| 1 | ! | 224.9700 | 56.14 | -14.36 | 41.78 | 46.00 | -4.22 | QP | | |
| 2 | * | 249.2200 | 55.32 | -13.50 | 41.82 | 46.00 | -4.18 | QP | | |
| 3 | ! | 268.6200 | 54.06 | -12.76 | 41.30 | 46.00 | -4.70 | QP | | |
| 4 | ! | 721.6100 | 44.38 | -3.94 | 40.44 | 46.00 | -5.56 | QP | | |
| 5 | | 786.6000 | 40.45 | -3.00 | 37.45 | 46.00 | -8.55 | QP | | |
| 6 | | 808.9100 | 40.64 | -2.72 | 37.92 | 46.00 | -8.08 | QP | | |

*:Maximum data x:Over limit !:over margin

Operator: csl

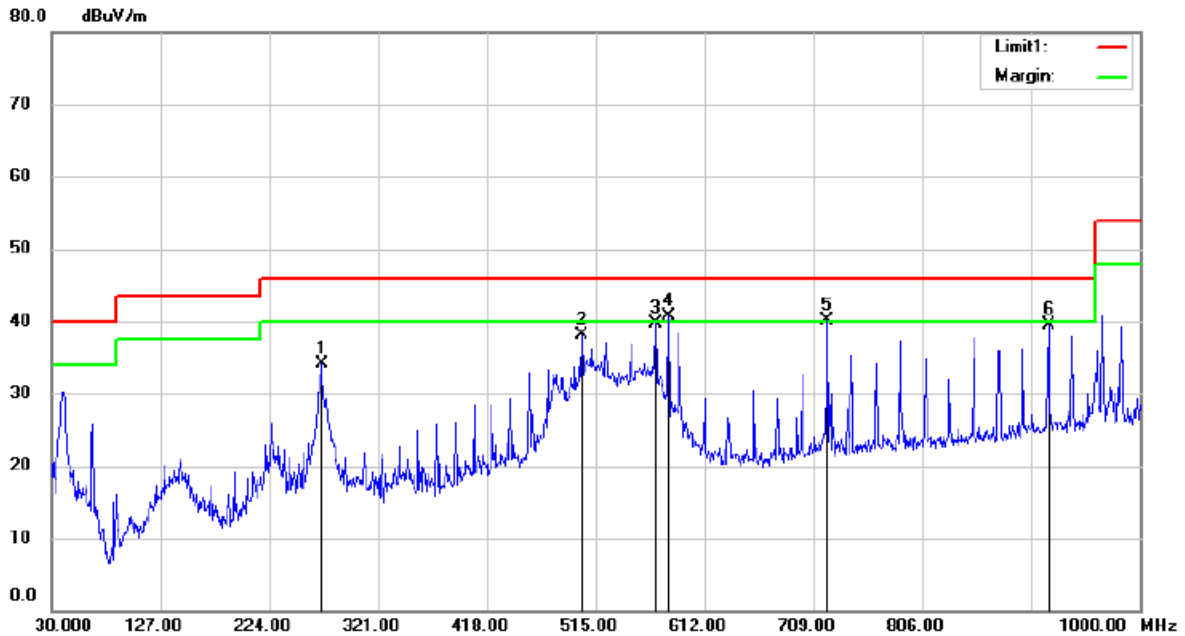

Site: 3m Chamber #3 Polarization: **Vertical** Temperature: 24 C
 Limit: (RE)FCC PART 15 CLASS B Power: AC 120V/60Hz Humidity: 53 %
 Mode:TX HIGH
 Note: ADAPTER:S12B22-120A100-C4

| No. | Mk. | Freq. MHz | Reading Level dBuV | Correct Factor dB | Measure- ment dBuV/m | Limit dBuV/m | Over dB | Antenna Height cm | Table Degree degree | Comment |
|-----|-----|--------------|--------------------------|-------------------------|----------------------------|-----------------|------------|-------------------------|---------------------------|---------|
| 1 | | 270.5600 | 46.74 | -12.71 | 34.03 | 46.00 | -11.97 | QP | | |
| 2 | | 502.3900 | 45.46 | -7.43 | 38.03 | 46.00 | -7.97 | QP | | |
| 3 | | 568.3500 | 46.15 | -6.35 | 39.80 | 46.00 | -6.20 | QP | | |
| 4 | * | 579.9900 | 46.92 | -6.17 | 40.75 | 46.00 | -5.25 | QP | | |
| 5 | ! | 721.6100 | 44.07 | -3.94 | 40.13 | 46.00 | -5.87 | QP | | |
| 6 | | 918.5200 | 40.86 | -1.28 | 39.58 | 46.00 | -6.42 | QP | | |

*:Maximum data x:Over limit !:over margin

Operator: csl

For adapter2

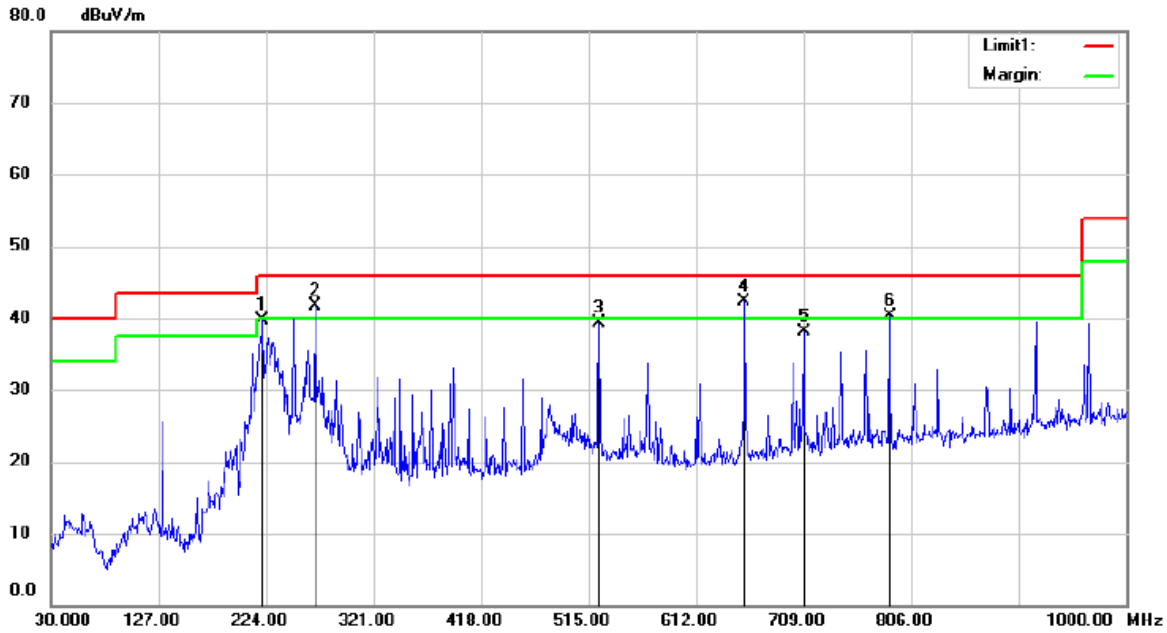

Site 3m Chamber #3 Polarization: *Horizontal* Temperature: 24 C
 Limit: (RE)FCC PART 15 CLASS B Power: AC 120V/60Hz Humidity: 53 %
 Note: ADAPTER:NBS05B050100VU

| No. | Mk. | Freq. | Reading Level | Correct Factor | Measurement | Limit | Over | Antenna Height | Table Degree | |
|-----|-----|----------|---------------|----------------|-------------|--------|-------|----------------|--------------|--------|
| | | MHz | dBuV | dB | dBuV/m | dBuV/m | dB | Detector | cm | degree |
| 1 | | 221.0900 | 54.13 | -14.47 | 39.66 | 46.00 | -6.34 | QP | | |
| 2 | ! | 268.6200 | 54.53 | -12.76 | 41.77 | 46.00 | -4.23 | QP | | |
| 3 | | 524.7000 | 46.45 | -7.06 | 39.39 | 46.00 | -6.61 | QP | | |
| 4 | * | 655.6500 | 47.23 | -4.95 | 42.28 | 46.00 | -3.72 | QP | | |
| 5 | | 709.0000 | 42.25 | -4.11 | 38.14 | 46.00 | -7.86 | QP | | |
| 6 | ! | 786.6000 | 43.28 | -3.00 | 40.28 | 46.00 | -5.72 | QP | | |

*:Maximum data x:Over limit !:over margin

Operator: csl

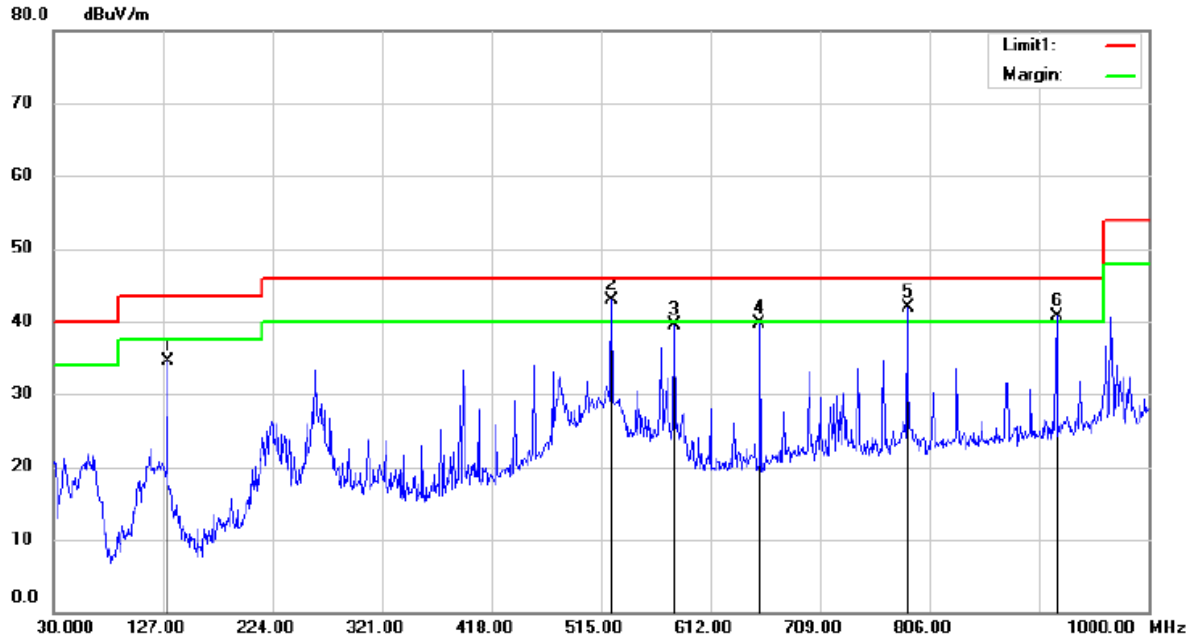

Site 3m Chamber #3 Polarization: **Vertical** Temperature: 24 C
 Limit: (RE)FCC PART 15 CLASS B Power: AC 120V/60Hz Humidity: 53 %
 Mode: TX LOW
 Note: ADAPTER:NBS05B050100VU

| No. | Mk. | Freq. | Reading Level | Correct Factor | Measurement | Limit | Over | Antenna Height | Table Degree | |
|-----|-----|----------|---------------|----------------|-------------|--------|-------|----------------|--------------|---------|
| | | MHz | dBuV | dB | dBuV/m | dBuV/m | dB | cm | degree | Comment |
| 1 | | 130.8800 | 52.98 | -18.52 | 34.46 | 43.50 | -9.04 | | | QP |
| 2 | * | 524.7000 | 49.88 | -7.06 | 42.82 | 46.00 | -3.18 | | | QP |
| 3 | | 579.9900 | 45.75 | -6.17 | 39.58 | 46.00 | -6.42 | | | QP |
| 4 | | 655.6500 | 44.61 | -4.95 | 39.66 | 46.00 | -6.34 | | | QP |
| 5 | ! | 786.6000 | 44.84 | -3.00 | 41.84 | 46.00 | -4.16 | | | QP |
| 6 | ! | 918.5200 | 41.99 | -1.28 | 40.71 | 46.00 | -5.29 | | | QP |

*:Maximum data x:Over limit !:over margin

Operator: csl

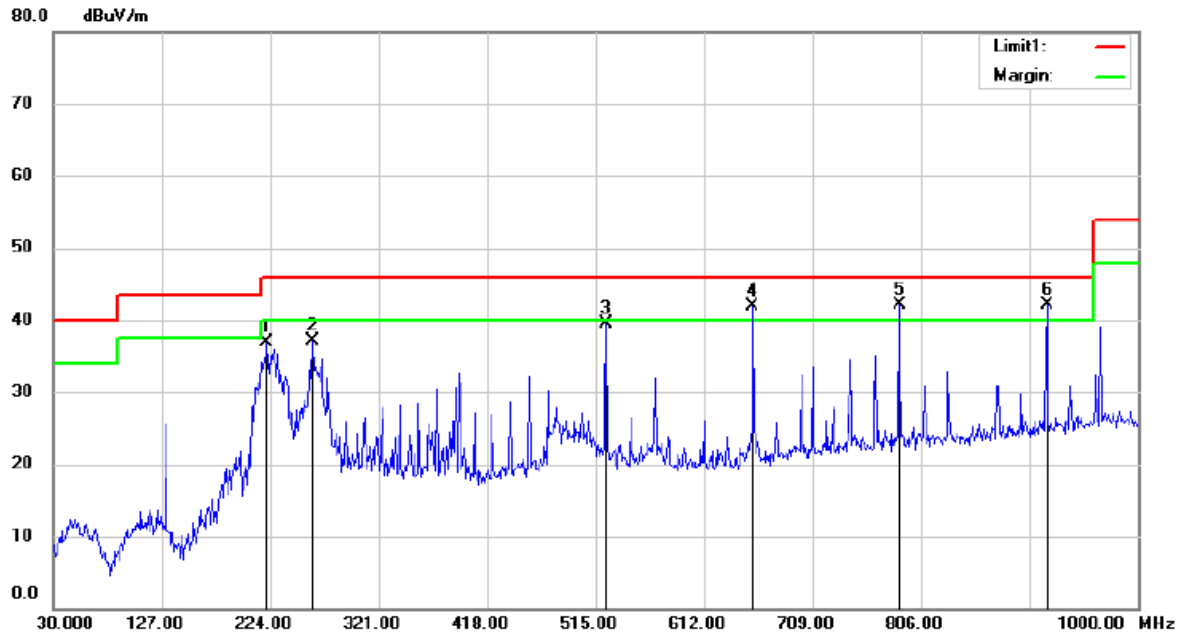

Site 3m Chamber #3 Polarization: *Horizontal* Temperature: 24 C
 Limit: (RE)FCC PART 15 CLASS B Power: AC 120V/60Hz Humidity: 53 %
 Mode:TX MID
 Note: ADAPTER:NBS05B050100VU

| No. | Mk. | Freq. MHz | Reading Level dBuV | Correct Factor dB | Measure- ment dBuV/m | Limit dBuV/m | Over dB | Antenna Height cm | Table Degree | Detector | Comment |
|-----|-----|--------------|--------------------------|-------------------------|----------------------------|-----------------|------------|-------------------------|-----------------|----------|---------|
| 1 | | 221.0900 | 51.45 | -14.47 | 36.98 | 46.00 | -9.02 | | | QP | |
| 2 | | 261.8300 | 50.04 | -12.94 | 37.10 | 46.00 | -8.90 | | | QP | |
| 3 | | 524.7000 | 46.51 | -7.06 | 39.45 | 46.00 | -6.55 | | | QP | |
| 4 | ! | 655.6500 | 46.87 | -4.95 | 41.92 | 46.00 | -4.08 | | | QP | |
| 5 | * | 786.6000 | 45.17 | -3.00 | 42.17 | 46.00 | -3.83 | | | QP | |
| 6 | ! | 918.5200 | 43.35 | -1.28 | 42.07 | 46.00 | -3.93 | | | QP | |

*:Maximum data x:Over limit !:over margin

Operator: csl

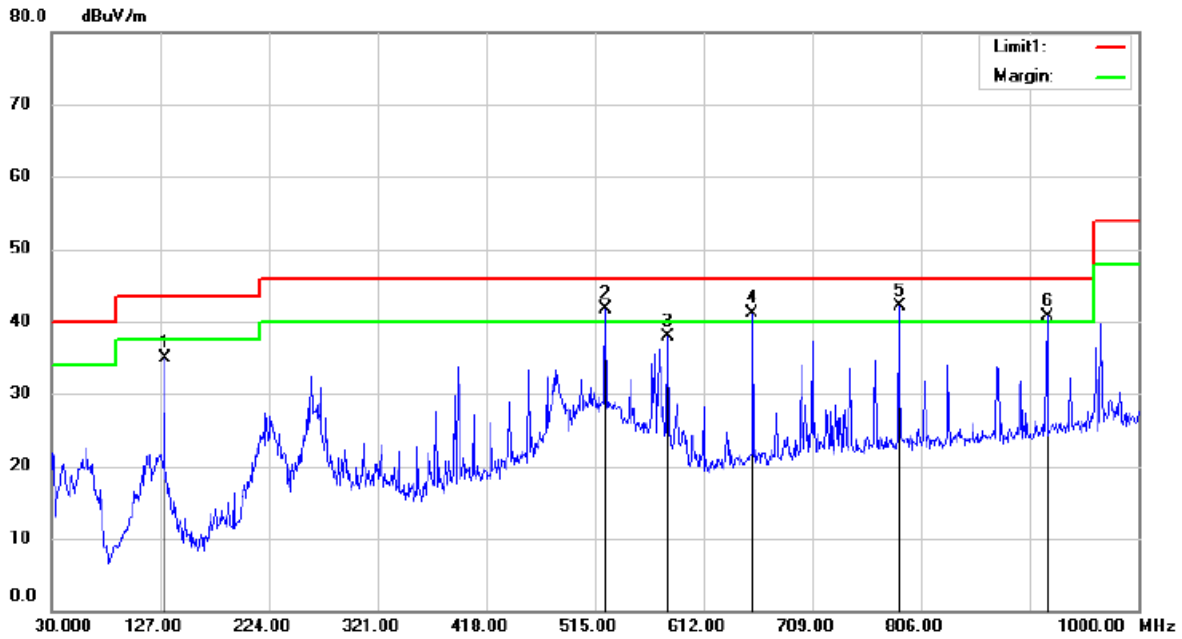

Site: 3m Chamber #3 Polarization: **Vertical** Temperature: 24 C
 Limit: (RE)FCC PART 15 CLASS B Power: AC 120V/60Hz Humidity: 53 %
 Mode:TX MID
 Note: ADAPTER:NBS05B050100VU

| No. | Mk. | Freq. MHz | Reading Level dBuV | Correct Factor dB | Measure- ment dBuV/m | Limit dBuV/m | Over dB | Antenna Height cm | Table Degree | Comment |
|-----|-----|--------------|--------------------------|-------------------------|----------------------------|-----------------|------------|-------------------------|-----------------|---------|
| 1 | | 130.8800 | 53.47 | -18.52 | 34.95 | 43.50 | -8.55 | | | QP |
| 2 | ! | 524.7000 | 48.86 | -7.06 | 41.80 | 46.00 | -4.20 | | | QP |
| 3 | | 579.9900 | 44.14 | -6.17 | 37.97 | 46.00 | -8.03 | | | QP |
| 4 | ! | 655.6500 | 46.13 | -4.95 | 41.18 | 46.00 | -4.82 | | | QP |
| 5 | * | 786.6000 | 45.02 | -3.00 | 42.02 | 46.00 | -3.98 | | | QP |
| 6 | ! | 918.5200 | 41.92 | -1.28 | 40.64 | 46.00 | -5.36 | | | QP |

*:Maximum data x:Over limit !:over margin

Operator: csl

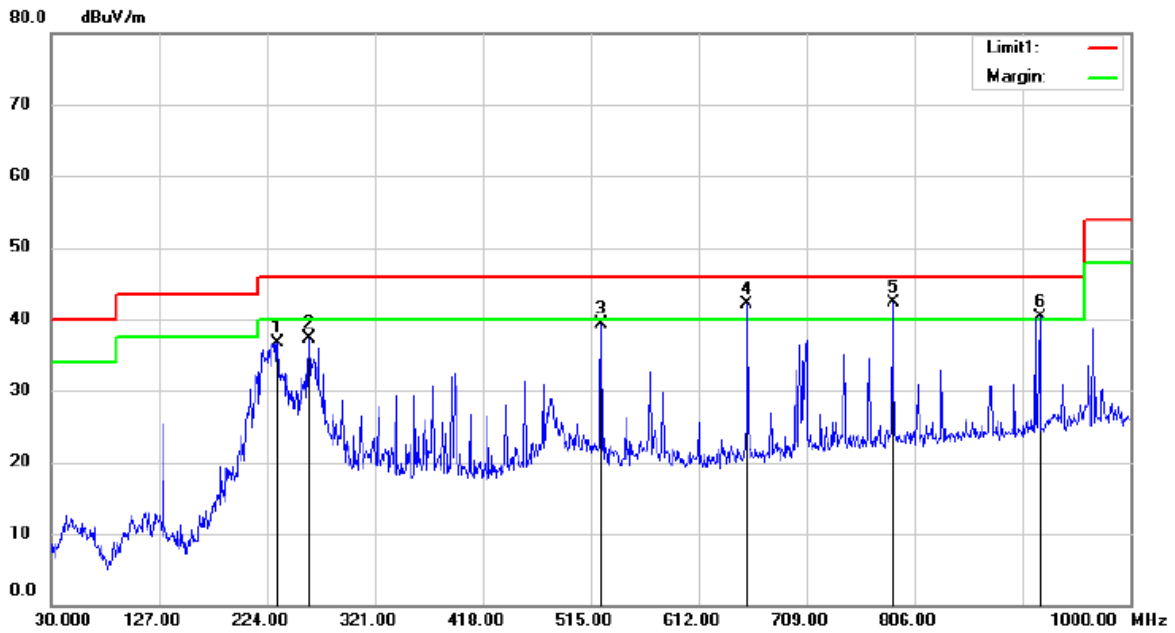

Site: 3m Chamber #3 Polarization: **Horizontal** Temperature: 24 C
 Limit: (RE)FCC PART 15 CLASS B Power: AC 120V/60Hz Humidity: 53 %
 Mode: TX HIGH
 Note: ADAPTER:NBS05B050100VU

| No. | Mk. | Freq. MHz | Reading Level dBuV | Correct Factor dB | Measure- ment dBuV/m | Limit dBuV/m | Over dB | Antenna Height cm | Table Degree degree | Comment |
|-----|-----|--------------|--------------------------|-------------------------|----------------------------|-----------------|------------|-------------------------|---------------------------|---------|
| 1 | | 233.7000 | 50.91 | -14.12 | 36.79 | 46.00 | -9.21 | | | QP |
| 2 | | 261.8300 | 50.22 | -12.94 | 37.28 | 46.00 | -8.72 | | | QP |
| 3 | | 524.7000 | 46.43 | -7.06 | 39.37 | 46.00 | -6.63 | | | QP |
| 4 | ! | 655.6500 | 47.12 | -4.95 | 42.17 | 46.00 | -3.83 | | | QP |
| 5 | * | 786.6000 | 45.38 | -3.00 | 42.38 | 46.00 | -3.62 | | | QP |
| 6 | ! | 918.5200 | 41.65 | -1.28 | 40.37 | 46.00 | -5.63 | | | QP |

*:Maximum data x:Over limit !:over margin

Operator: csl

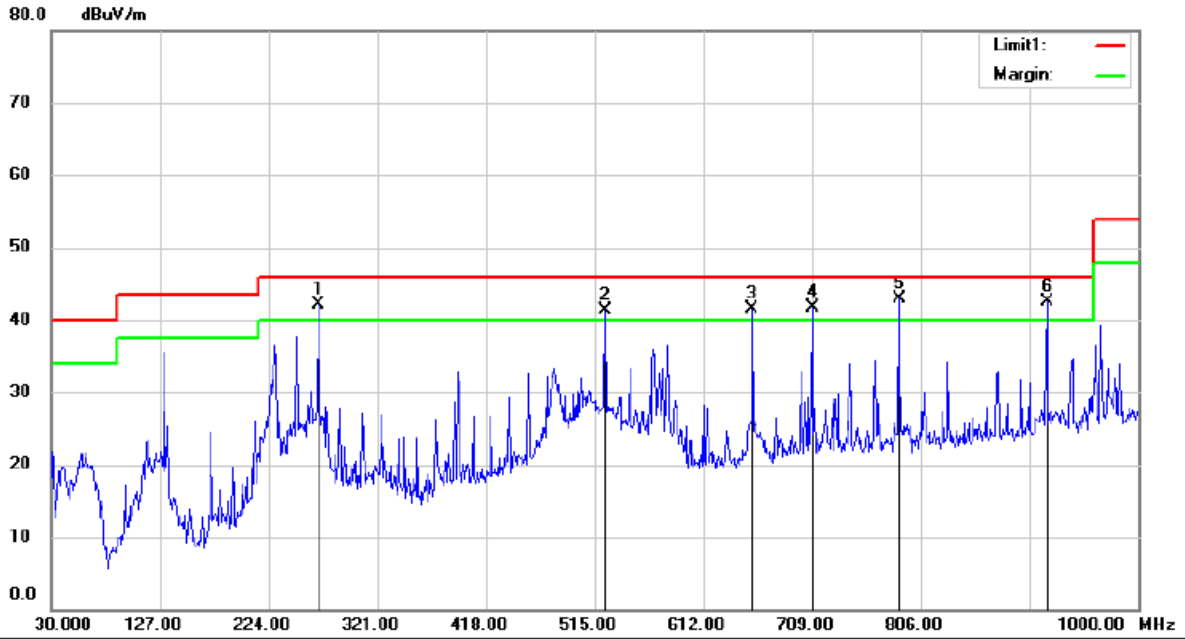

Site 3m Chamber #3 Polarization: **Vertical** Temperature: 24 C
 Limit: (RE)FCC PART 15 CLASS B Power: AC 120V/60Hz Humidity: 53 %
 Mode:TX HIGH
 Note: ADAPTER:NBS05B050100VU

| No. | Mk. | Freq. MHz | Reading Level dBuV | Correct Factor dB | Measure- ment dBuV/m | Limit dBuV/m | Over dB | Antenna Height cm | Table Degree | Comment |
|-----|-----|--------------|--------------------------|-------------------------|----------------------------|-----------------|------------|-------------------------|-----------------|---------|
| 1 | ! | 268.6200 | 54.80 | -12.76 | 42.04 | 46.00 | -3.96 | QP | | |
| 2 | ! | 524.7000 | 48.35 | -7.06 | 41.29 | 46.00 | -4.71 | QP | | |
| 3 | ! | 655.6500 | 46.44 | -4.95 | 41.49 | 46.00 | -4.51 | QP | | |
| 4 | ! | 709.0000 | 45.77 | -4.11 | 41.66 | 46.00 | -4.34 | QP | | |
| 5 | * | 786.6000 | 45.97 | -3.00 | 42.97 | 46.00 | -3.03 | QP | | |
| 6 | ! | 918.5200 | 43.69 | -1.28 | 42.41 | 46.00 | -3.59 | QP | | |

*:Maximum data x:Over limit !:over margin Operator: csl

8.6 CONDUCTED EMISSIONS TEST

8.6.1 Applicable Standard

According to FCC Part 15.207(a)

8.6.2 Conformance Limit

| Conducted Emission Limit | | |
|--------------------------|------------|---------|
| Frequency(MHz) | Quasi-peak | Average |
| 0.15-0.5 | 66-56 | 56-46 |
| 0.5-5.0 | 56 | 46 |
| 5.0-30.0 | 60 | 50 |

Note: 1. The lower limit shall apply at the transition frequencies
 2. The limit decreases in line with the logarithm of the frequency in the range of 0.15 to 0.50MHz.

8.6.3 Test Configuration

Test according to clause 7.3 conducted emission test setup

8.6.4 Test Procedure

The EUT was placed on a table which is 0.8m above ground plane.
 Maximum procedure was performed on the highest emissions to ensure EUT compliance.
 Repeat above procedures until all frequency measured were complete.

8.6.5 Test Results

Pass

We test the EUT at 120V and 240V all modes 2.4G 802.11b/g/n with adapter1 and adapter2, and show the worst result as bellow.

For adapter1

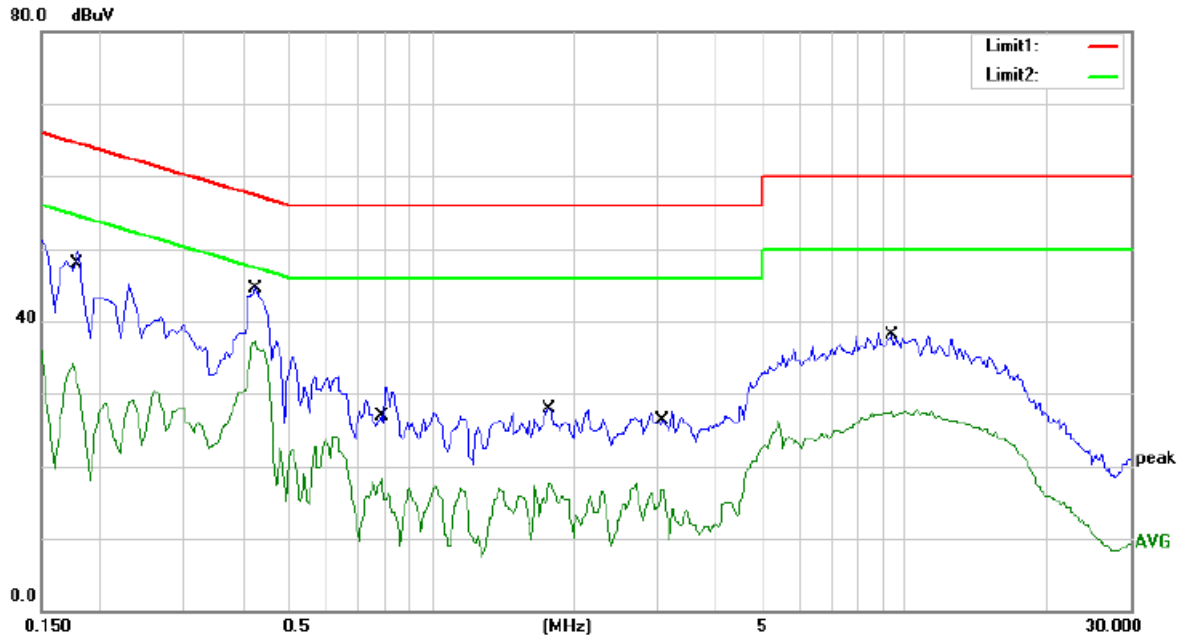

Site Conduction #1 Phase: **L1** Temperature: 22
 Limit: (CE)FCC PART 15 class B_QP Power: AC 120V/60Hz Humidity: 55 %
 Mode: TX
 Note: ADAPTER:S12B22-120A100-C4

| No. | Mk. | Freq. | Reading Level | Correct Factor | Measurement | Limit | Over | Detector | Comment |
|-----|-----|--------|---------------|----------------|-------------|-------|--------|----------|---------|
| | | MHz | dBuV | dB | dBuV | dBuV | dB | | |
| 1 | | 0.1750 | 49.77 | 0.00 | 49.77 | 64.72 | -14.95 | QP | |
| 2 | | 0.1750 | 34.09 | 0.00 | 34.09 | 54.72 | -20.63 | AVG | |
| 3 | | 0.4250 | 44.60 | 0.00 | 44.60 | 57.35 | -12.75 | QP | |
| 4 | * | 0.4250 | 37.22 | 0.00 | 37.22 | 47.35 | -10.13 | AVG | |
| 5 | | 0.7850 | 31.00 | 0.00 | 31.00 | 56.00 | -25.00 | QP | |
| 6 | | 0.7850 | 18.31 | 0.00 | 18.31 | 46.00 | -27.69 | AVG | |
| 7 | | 1.7750 | 27.81 | 0.00 | 27.81 | 56.00 | -28.19 | QP | |
| 8 | | 1.7750 | 17.71 | 0.00 | 17.71 | 46.00 | -28.29 | AVG | |
| 9 | | 3.0900 | 27.44 | 0.00 | 27.44 | 56.00 | -28.56 | QP | |
| 10 | | 3.0900 | 16.64 | 0.00 | 16.64 | 46.00 | -29.36 | AVG | |
| 11 | | 9.4500 | 38.08 | 0.00 | 38.08 | 60.00 | -21.92 | QP | |
| 12 | | 9.4500 | 27.44 | 0.00 | 27.44 | 50.00 | -22.56 | AVG | |

:Maximum data x:Over limit !:over margin Comment: Factor build in receiver. Operator:

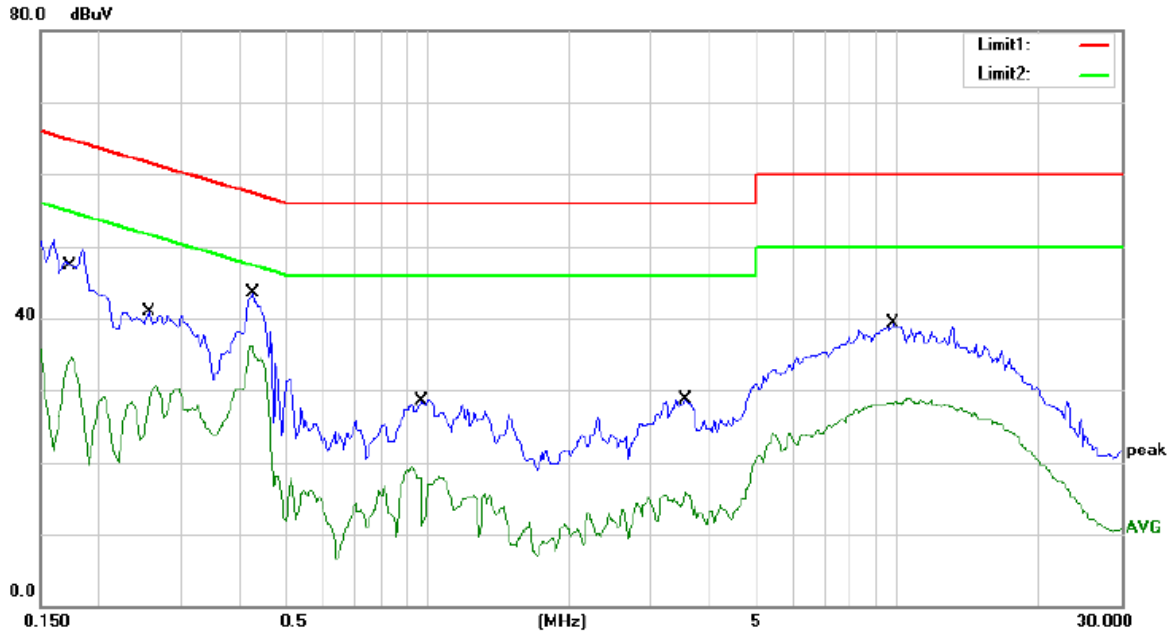

Site Conduction #1
 Limit: (CE)FCC PART 15 class B_QP
 Mode: TX
 Note: ADAPTER:S12B22-120A100-C4

Phase: **N** Temperature: 22
 Power: AC 120V/60Hz Humidity: 55 %

| No. | Mk. | Freq. MHz | Reading Level dBuV | Correct Factor dB | Measure- ment dBuV | Limit dBuV | Over dB | Detector | Comment |
|-----|-----|--------------|--------------------------|-------------------------|--------------------------|---------------|------------|----------|---------|
| 1 | | 0.1758 | 49.48 | 0.00 | 49.48 | 64.68 | -15.20 | QP | |
| 2 | | 0.1758 | 34.34 | 0.00 | 34.34 | 54.68 | -20.34 | AVG | |
| 3 | | 0.2550 | 40.85 | 0.00 | 40.85 | 61.59 | -20.74 | QP | |
| 4 | | 0.2550 | 30.60 | 0.00 | 30.60 | 51.59 | -20.99 | AVG | |
| 5 | | 0.4250 | 43.54 | 0.00 | 43.54 | 57.35 | -13.81 | QP | |
| 6 | * | 0.4250 | 36.18 | 0.00 | 36.18 | 47.35 | -11.17 | AVG | |
| 7 | | 0.9632 | 28.69 | 0.00 | 28.69 | 56.00 | -27.31 | QP | |
| 8 | | 0.9632 | 17.90 | 0.00 | 17.90 | 46.00 | -28.10 | AVG | |
| 9 | | 3.5350 | 28.74 | 0.00 | 28.74 | 56.00 | -27.26 | QP | |
| 10 | | 3.5350 | 15.83 | 0.00 | 15.83 | 46.00 | -30.17 | AVG | |
| 11 | | 9.8300 | 39.29 | 0.00 | 39.29 | 60.00 | -20.71 | QP | |
| 12 | | 9.8300 | 28.50 | 0.00 | 28.50 | 50.00 | -21.50 | AVG | |

*:Maximum data x:Over limit !:over margin Comment: Factor build in receiver. Operator:

For adapter2

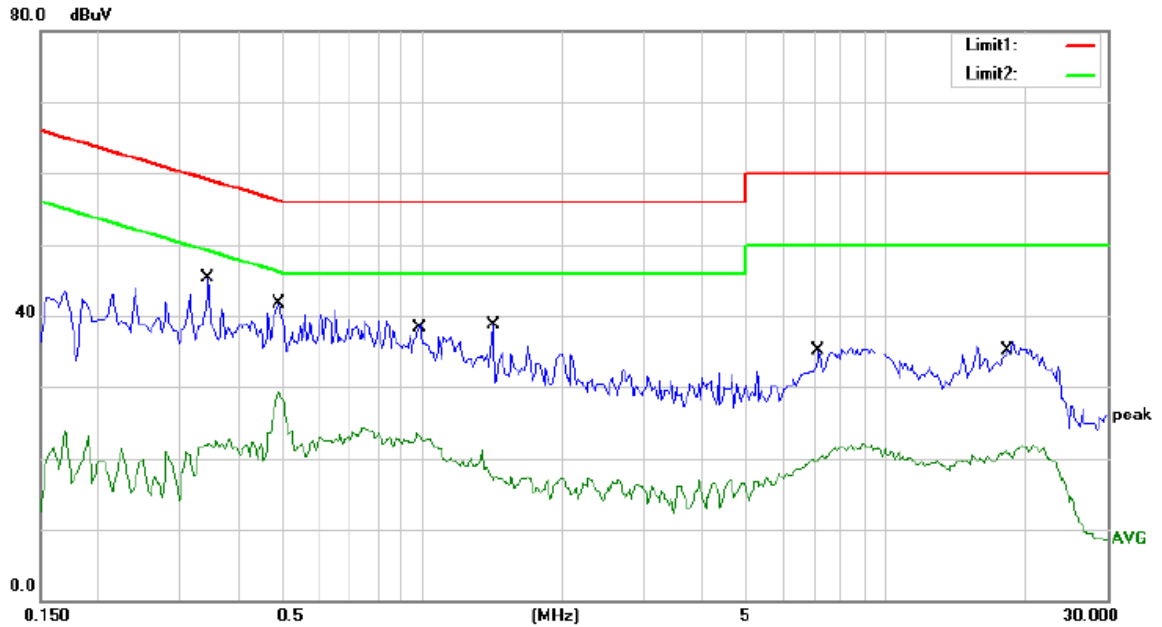

Site Conduction #1 Phase: **L1** Temperature: 22
 Limit: (CE)FCC PART 15 class B_QP Power: AC 120V/60Hz Humidity: 55 %
 Mode: TX
 Note: ADAPTER:NBS05B050100VU

| No. | Mk. | Freq. MHz | Reading Level dBuV | Correct Factor dB | Measure- ment dBuV | Limit dBuV | Over dB | Detector | Comment |
|-----|-----|--------------|--------------------------|-------------------------|--------------------------|---------------|------------|----------|---------|
| 1 | * | 0.3450 | 45.35 | 0.00 | 45.35 | 59.08 | -13.73 | QP | |
| 2 | | 0.3450 | 22.58 | 0.00 | 22.58 | 49.08 | -26.50 | AVG | |
| 3 | | 0.4900 | 41.61 | 0.00 | 41.61 | 56.17 | -14.56 | QP | |
| 4 | | 0.4900 | 29.32 | 0.00 | 29.32 | 46.17 | -16.85 | AVG | |
| 5 | | 0.9750 | 37.89 | 0.00 | 37.89 | 56.00 | -18.11 | QP | |
| 6 | | 0.9750 | 23.52 | 0.00 | 23.52 | 46.00 | -22.48 | AVG | |
| 7 | | 1.4032 | 38.75 | 0.00 | 38.75 | 56.00 | -17.25 | QP | |
| 8 | | 1.4032 | 17.93 | 0.00 | 17.93 | 46.00 | -28.07 | AVG | |
| 9 | | 7.1500 | 35.06 | 0.00 | 35.06 | 60.00 | -24.94 | QP | |
| 10 | | 7.1500 | 20.22 | 0.00 | 20.22 | 50.00 | -29.78 | AVG | |
| 11 | | 18.1352 | 36.24 | 0.00 | 36.24 | 60.00 | -23.76 | QP | |
| 12 | | 18.1352 | 20.99 | 0.00 | 20.99 | 50.00 | -29.01 | AVG | |

*:Maximum data x:Over limit !:over margin Comment: Factor build in receiver. Operator:

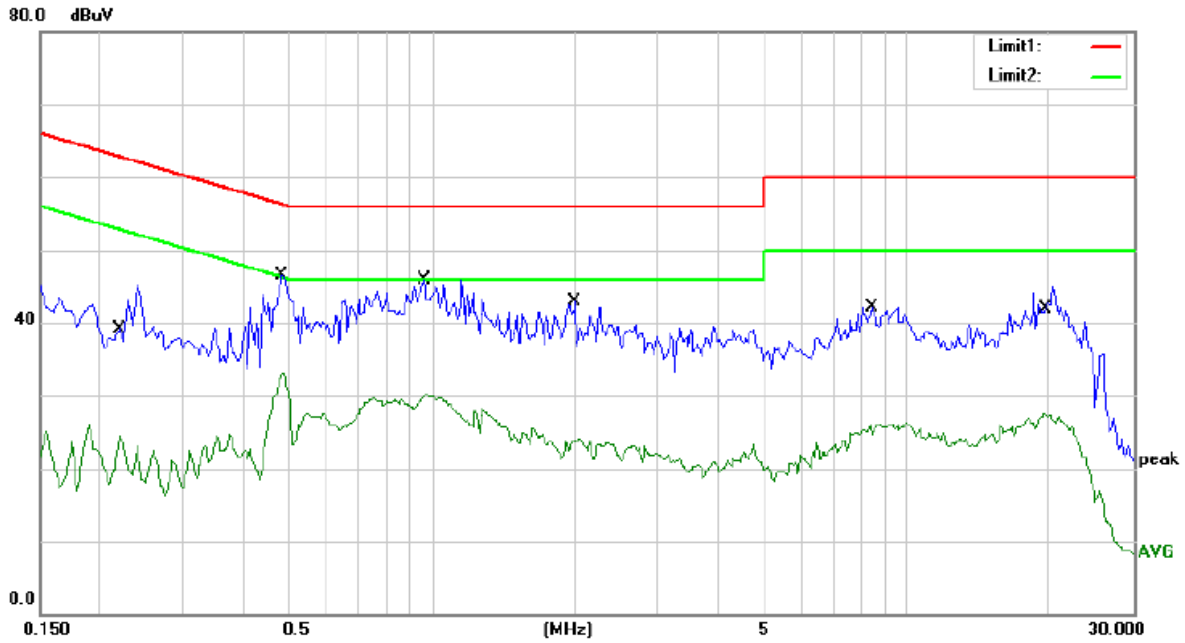

Site Conduction #1 Phase: **N** Temperature: 22
 Limit: (CE)FCC PART 15 class B_QP Power: AC 120V/60Hz Humidity: 55 %
 Mode: TX
 Note: ADAPTER:NBS05B050100VU

| No. | Mk. | Freq. | Reading Level | Correct Factor | Measurement | Limit | Over | Detector | Comment |
|-----|-----|---------|---------------|----------------|-------------|-------|--------|----------|---------|
| | | MHz | dBuV | dB | dBuV | dBuV | dB | | |
| 1 | | 0.2200 | 45.33 | 0.00 | 45.33 | 62.82 | -17.49 | QP | |
| 2 | | 0.2200 | 24.52 | 0.00 | 24.52 | 52.82 | -28.30 | AVG | |
| 3 | * | 0.4850 | 46.53 | 0.00 | 46.53 | 56.25 | -9.72 | QP | |
| 4 | | 0.4850 | 33.09 | 0.00 | 33.09 | 46.25 | -13.16 | AVG | |
| 5 | | 0.9650 | 45.97 | 0.00 | 45.97 | 56.00 | -10.03 | QP | |
| 6 | | 0.9650 | 30.04 | 0.00 | 30.04 | 46.00 | -15.96 | AVG | |
| 7 | | 2.0100 | 42.94 | 0.00 | 42.94 | 56.00 | -13.06 | QP | |
| 8 | | 2.0100 | 24.11 | 0.00 | 24.11 | 46.00 | -21.89 | AVG | |
| 9 | | 8.3700 | 42.16 | 0.00 | 42.16 | 60.00 | -17.84 | QP | |
| 10 | | 8.3700 | 25.85 | 0.00 | 25.85 | 50.00 | -24.15 | AVG | |
| 11 | | 19.4000 | 44.86 | 0.00 | 44.86 | 60.00 | -15.14 | QP | |
| 12 | | 19.4000 | 27.49 | 0.00 | 27.49 | 50.00 | -22.51 | AVG | |

:Maximum data x:Over limit !:over margin Comment: Factor build in receiver. Operator:

8.7 ANTENNA APPLICATION

8.7.1 Antenna Requirement

| Standard | Requirement |
|---------------------|--|
| FCC CRF Part 15.203 | An intentional radiator shall be designed to ensure that no antenna other than that furnished by the responsible party shall be used with the device. The use of a permanently attached antenna or of an antenna that uses a unique coupling to the intentional radiator shall be considered sufficient to comply with the provisions of this section. The manufacturer may design the unit so that a broken antenna can be replaced by the user, but the use of a standard antenna jack or electrical connector is prohibited. This requirement does not apply to carrier current devices or to devices operated under the provisions of §15.211, §15.213, §15.217, §15.219, or §15.221. Further, this requirement does not apply to intentional radiators that must be professionally installed, such as perimeter protection systems and some field disturbance sensors, or to other intentional radiators which, in accordance with §15.31(d), must be measured at the installation site. However, the installer shall be responsible for ensuring that the proper antenna is employed so that the limits in this part are not exceeded. |

For intentional device, according to FCC 47 CFR Section 15.203, an intentional radiator shall be designed to ensure that no antenna other than that furnished by the responsible party shall be used with the device. And according to FCC 47 CFR Section 15.247 (b), if transmitting antennas of directional gain greater than 6dBi are used, the power shall be reduced by the amount in dB that the directional gain of the antenna exceeds 6dBi.

8.7.2 Result

PASS.

The EUT has 1 antenna: two PiFa Antennas for wifi 2.4G, the gain is 2.5 dBi;

- Note:
- Antenna use a permanently attached antenna which is not replaceable.
 - Not using a standard antenna jack or electrical connector for antenna replacement
 - The antenna has to be professionally installed (please provide method of installation)

which in accordance to section 15.203, please refer to the internal photos.