

OXYGEN BROADBAND S.A.**SUNLIGHT BMS DISPLAY
DISPLAY TELECOMMUNICATION BOX
H/W and S/W Technical Specification**

This document contains confidential proprietary information and is the property of Oxygen Broadband s.a. The contents of this document may not be disclosed to any unauthorized person without the written consent of Oxygen Broadband s.a.

1. REVISION HISTORY

Revision	Date	Author	Comments
1.0	13/4/2021	M. Petouris	First release.
1.0	28/4/2021	P.Paravoliasis	Additions and descriptions.



BMS Display image.

2. INTRODUCTION

The **Sunlight BMS DISPLAY** device is designed to be used in industrial environment and warehouses, both indoors and outdoors. It is used only for monitoring battery cells and transmitting the information and data requested to the cloud service of the client. Operation of the device should be only performed by specialized and trained personel.

This document describes the **Sunlight BMS DISPLAY** product based on the NXP I.MX 6ULL single-core processor with ARM Cortex-A7 Core. The following diagram depicts the building blocks of the I.MX 6 chipset.

I.MX 6ULL

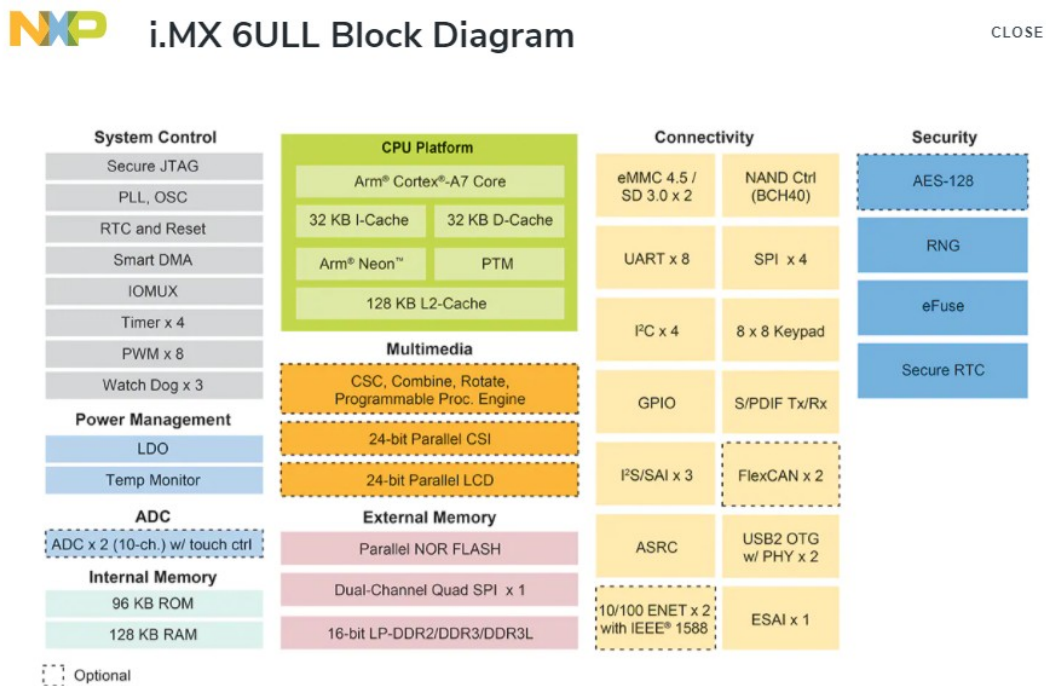

Peripheral to the NXP chipset, the device also has the EG91 GSM/GPS LTE module from Quectel, the LINK6223E wifi module from FNLink, a USB2.0 A-type interface, a TFT display (240*320) 16 RGB for user defined information, a light sensor, a touch sensor, a DDR3L 2Gbit IC, a QSPI serial flash 16Mbit and a serial NAND Flash 1Gbit. The device also has an Internal Li-Ion battery at 300 mAh.

IoT Broadband Gateway- Technical Specification, v1.0

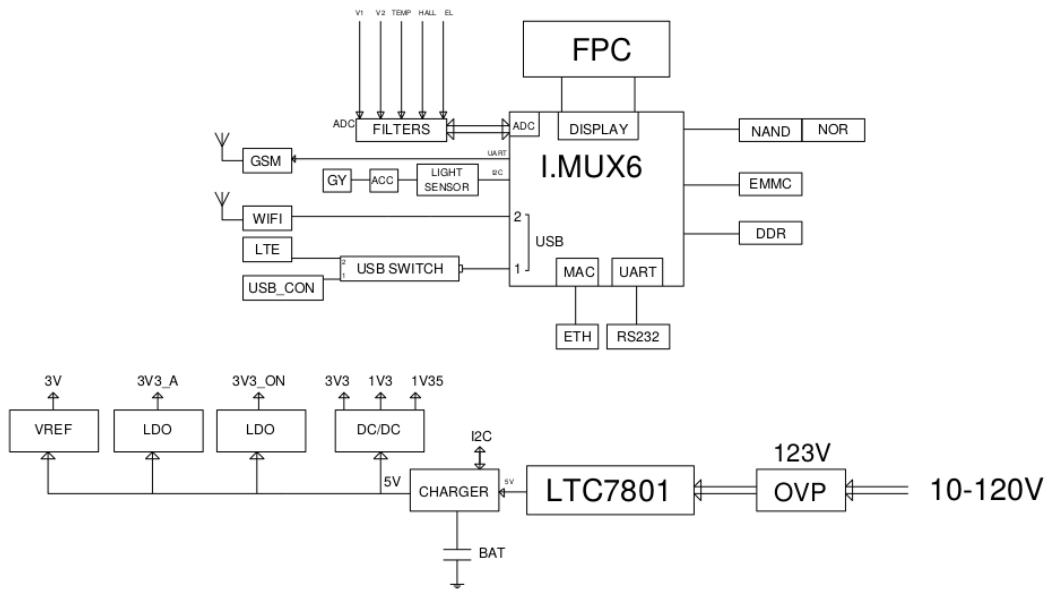

The i.MX 6ULL is a power efficient and cost-optimized applications processor family featuring an advanced implementation of a single Arm Cortex-A7 core, which operates at speeds up to 900 MHz.

The EG91 is an LTE category module, and comes in three versions -EX, -NAX, -AUX, depending on the geographic area of operation. It delivers maximum downlink rates of 10Mbps and uplink rates of 5Mbps under LTE. It is also backward-compatible with existing UMTS/HSPA+ networks. Also it provides GPS location data of the device, available for the end user.

The 6223E is a 2.4G WIFI/Bluetooth module, operates at 2.4GHz and support IEEE standards, IEEE 802.11b, IEEE 802.11g, IEEE 802.11n, IEEE 802.11d, IEEE 802.11e, IEEE 802.11h, IEEE 802.11i. It is fully qualified for BT2.1, BT3.0 and BT4.0 dual mode.

3. HARDWARE FEATURES

3.1. Silicon Chips

Function	Description
CPU	NXP i.MX 6ULL Cortex-A7 Core Industrial grade
LTE	Quectel EG91 (-EX, -NAX, -AUX) GSM/GPS Module -EX : FDD LTE : B1/B3/B7/B8/B20/B28 , WCDMA B1/B8, GSM 900/1800 MHz , -NAX FDD LTE : B2/B4/B5/B12/B13/B25/B26, WCDMA B2/B4/B5 -AUX FDD LTE : B1/B2/B3/B4/B5/B7/B8/B28/B66, WCDMA : B1/B2/B5/B8 GSM : B2/B3/B5/B8 GPS, GLONASS, BeiDou/Compass, Galileo, QZSS
WIFI	FNLink LN_6223E Module 2.4 GHz, IEEE 802.11bgndehi, Bluetooth 2.1, 3.0, 4.2 up to 150 Mbps up/down PHY rates
Light sensor	sense
DDR3L Memory	2Gb
QSPI FLASH	16Mb
NAND Memory	1Gb NAND Flash

3.2. Physical Ports / Switches

Label	No	Type	Color	Description
Touch pad	1	Touch sensor	-	Switch between screens
Light Sensor	1	Light sensor	Transparent	Dims screen depending on lighting conditions.
USB	1	Type A Female	white	USB 2.0 Host interface for connection of peripheral devices
Power Cable	1	Multi Core	Black	Connects to power supply using the WEIPU interconnector
WEIPU interconnector	1	Power supply	Grey	Power supply plug

3.3. Power Supply

Internal DC/DC Switching power supply

Input : 12-120VDC

Power consumption : 1.48W normal mode

3.4. *Certifications / Safety / Environmental*

Function	Description
FCC SDoC	47 CFR FCC PART 15, Subpart B, Class A
CE-RED: (Directive 2014/53/EU)	ETSI EN 300 328 ETSI EN 301 511 ETSI EN 301 908-1 ETSI EN 301 908-2 ETSI EN 301 908-13 ETSI EN 303 413 ETSI EN 301 489-1 ETSI EN 301 489-17 ETSI EN 301 489-19 ETSI EN 301 489-52 EN 62311 EN 50665 EN 62368-1
CE-RoHS: (Directive 2011/65/EU)	EN 63000
Production	Quality assurance, thermal test
Temperature Range	Operaton: -10 to +45°C Storage: -20 to +95°C
Humidity Range	Operation: 10 to 90% RH Storage: 5 to 95% RH
Power dissipation	Typical 20 BTU/h, Max 45 BTU/h
MTBF	Over 35,000 hours
Warranty	24 months

3.5. *Other*

- 8 layers PCB,ROHS, Main Board
- 4 layers PCB,ROHS, Daughter Board (LTE Module)

3.6. Statements

FCC Statement:

This device complies with Part 15 of the FCC Rules. Operation is subject to the following two conditions:

- (1) This device may not cause harmful interference.
- (2) This device must accept any interference received, including interference that may cause undesired operation.

NOTE: This equipment has been tested and found to comply with the limits for a Class A digital device, pursuant to part 15 of the FCC Rules. These limits are designed to provide reasonable protection against harmful interference when the equipment is operated in a commercial environment. This equipment generates, uses, and can radiate radio frequency energy and, if not installed and used in accordance with the instruction manual, may cause harmful interference to radio communications. Operation of this equipment in a residential area is likely to cause harmful interference in which case the user will be required to correct the interference at his own expense.

WARNING:

Changes or modifications not expressly approved by the party responsible for compliance could void the user's authority to operate the equipment.

RF Exposure

This equipment complies with FCC radiation exposure limits set forth for an uncontrolled environment. This equipment should be installed and operated with minimum 20cm distance between the radiator & your body.

4. SOFTWARE FEATURES

The main S/W applications running on the device include:

- Full IPv6 support, including tunneling (IPv4-over-IPv6, IPv6-over-IPv4)
- Dynamic backup operation between different WAN connections
- Netfilter iptables with layer-7 filtering enabled
- SSL libraries
- SSH server/client
- OpenVPN server/client
- IPsec server/client
- PPTP server/client
- L2TP server/client
- SSL server/client
- Routing daemon for dynamic routing protocols (RIP, OSPF, BGP)
- DHCP server/client
- HTTP server
- UPnP daemon
- FTP server
- File server
- DNS proxy
- DynDNS client
- Perl interpreter
- URL filtering application