

**FCC 47 CFR PART 15 SUBPART E**

**DFS TEST REPORT**

*For*

Wi-Fi Dual-band 2X2 11ac +Bluetooth V4.2 Module

MODEL No.: 6222D-UUB

FCC ID: 2AATL-6222D-UUB

Trade Mark: N/A

REPORT NO.: ES180621035W

ISSUE DATE: July 09, 2018

*Prepared for*

**FN-LINK TECHNOLOGY LIMITED**  
No. 8, Litong Road, Liuyang Economic Development Zone, Liuyang City,  
Hunan Province, China

*Prepared by*

**EMTEK(SHENZHEN) CO., LTD.**

Bldg 69, Majialong Industry Zone, Nanshan District,  
Shenzhen, Guangdong, China  
TEL: 86-755-26954280  
FAX: 86-755-26954282

## TABLE OF CONTENTS

<b>1.</b>	<b>TEST RESULT CERTIFICATION.....</b>	<b>3</b>
<b>2.</b>	<b>EUT DESCRIPTION .....</b>	<b>3</b>
<b>3.</b>	<b>SUMMARY OF TEST RESULT .....</b>	<b>5</b>
<b>4.</b>	<b>TEST METHODOLOGY .....</b>	<b>6</b>
4.1	GENERAL DESCRIPTION OF APPLIED STANDARDS .....	6
4.2	MEASUREMENT EQUIPMENT USED .....	6
4.3	DESCRIPTION OF TEST MODES.....	6
<b>5.</b>	<b>FACILITIES AND ACCREDITATIONS .....</b>	<b>9</b>
5.1	FACILITIES.....	9
5.2	EQUIPMENT .....	9
5.3	LABORATORY ACCREDITATIONS AND LISTINGS .....	9
<b>6.</b>	<b>SETUP OF EQUIPMENT UNDER TEST .....</b>	<b>10</b>
6.1	SETUP CONFIGURATION OF EUT .....	10
6.2	CALIBRATION OF DFS DETECTION THRESHOLD LEVEL: .....	10
6.3	SUPPORT EQUIPMENT.....	11
<b>7.</b>	<b>DYNAMIC FREQUENCY SELECTION REQUIREMENTS.....</b>	<b>12</b>
7.1	APPLICABLE STANDARD.....	12
7.2	CONFORMANCE LIMIT .....	12
7.3	TEST CONFIGURATION .....	12
7.4	TEST PARAMETERS OF DFS TEST SIGNAL.....	13
7.5	TRANSMITTER OUTPUT POWER.....	14
7.6	OPERATION MODES AND REQUIREMENT TEST ITEMS .....	15
7.7	TEST PROCEDURE .....	15
<b>8.</b>	<b>TEST RESULT.....</b>	<b>16</b>
8.1	DETAILED TEST RESULTS.....	16
8.2	RADAR WAVEFORM.....	17
8.3	IN-SERVICE MONITORING.....	20

**1. TEST RESULT CERTIFICATION**

Applicant:	FN-LINK TECHNOLOGY LIMITED No. 8, Litong Road, Liuyang Economic Development Zone, Liuyang City, Hunan Province, China
Manufacturer:	FN-LINK TECHNOLOGY LIMITED No. 8, Litong Road, Liuyang Economic Development Zone, Liuyang City, Hunan Province, China
Product Description:	Wi-Fi Dual-band 2X2 11ac +Bluetooth V4.2 Module
Model Number:	6222D-UUB
Trade Mark:	N/A
File Number:	ES180621035W

Measurement Procedure Used:

APPLICABLE STANDARDS	
STANDARD	TEST RESULT
FCC-13-22 FCC 47 CFR Part 15, Subpart E	PASS

The above equipment was tested by EMTEK(SHENZHEN) CO., LTD.. The test data, data evaluation, test procedures, and equipment configurations shown in this report were made in accordance with the procedures given in ANSI C63.10 (2013) and the energy emitted by the sample EUT tested as described in this report is in compliance with the requirements of FCC Rules Part 2 and Part 15.407.

The test results of this report relate only to the tested sample identified in this report.

Date of Test : June 21, 2018 to July 05, 2018

Prepared by : *Yaping Shen*  
Yaping Shen/Editor

Reviewer : *Joe Xia*  
Joe Xia/Supervisor

Approve & Authorized Signer : *[Signature]*  
Lisa Wang/Manager



**2. EUT DESCRIPTION**

Characteristics	Description																																												
<b>IEEE 802.11 WLAN Mode Supported</b>	<input checked="" type="checkbox"/> 802.11a(20MHz channel bandwidth) <input checked="" type="checkbox"/> 802.11n(20MHz channel bandwidth) <input checked="" type="checkbox"/> 802.11n(40MHz channel bandwidth) <input checked="" type="checkbox"/> 802.11ac(20MHz channel bandwidth) <input checked="" type="checkbox"/> 802.11ac(40MHz channel bandwidth) <input checked="" type="checkbox"/> 802.11ac(80MHz channel bandwidth)																																												
<b>Data Rate</b>	802.11 a:6,9,12,18,24,36,48,54Mbps; 802.11n(HT20)/ac(HT20): MCS0-MCS15; 802.11n(HT40): MCS0-MCS15; 802.11ac(HT40):MCS0-MCS15; 802.11ac(VHT80):MCS0-MCS15;																																												
<b>Modulation</b>	OFDM with BPSK/QPSK/16QAM/64QAM for 802.11a/n; OFDM with BPSK/QPSK/16QAM/64QAM/256QAM for 802.11ac;																																												
<b>Operating Frequency Range</b>	<table border="1"> <thead> <tr> <th>WIFI 5G Band</th> <th>Mode</th> <th>Frequency Range(MHz)</th> <th>Number of channels</th> </tr> </thead> <tbody> <tr> <td rowspan="3">UNII Band I</td> <td>802.11a/n(HT20)/ac(VHT20)</td> <td>5180-5240</td> <td>4</td> </tr> <tr> <td>802.11n(HT40)/ac(VHT40)</td> <td>5190-5230</td> <td>2</td> </tr> <tr> <td>802.11 ac(VHT80)</td> <td>5210</td> <td>1</td> </tr> <tr> <td rowspan="3">UNII Band II-A</td> <td>802.11a/n(HT20)/ac(VHT20)</td> <td>5260-5320</td> <td>4</td> </tr> <tr> <td>802.11n(HT40)/ac(VHT40)</td> <td>5270-5310</td> <td>2</td> </tr> <tr> <td>802.11 ac(VHT80)</td> <td>5290</td> <td>1</td> </tr> <tr> <td rowspan="3">UNII Band II-C</td> <td>802.11a/n(HT20)/ac(VHT20)</td> <td>5500-5700</td> <td>11</td> </tr> <tr> <td>802.11n(HT40)/ac(VHT40)</td> <td>5510-5670</td> <td>5</td> </tr> <tr> <td>802.11 ac(VHT80)</td> <td>5530-5610</td> <td>2</td> </tr> <tr> <td rowspan="3">UNII Band III</td> <td>802.11a/n(HT20)/ac(VHT20)</td> <td>5745-5825</td> <td>5</td> </tr> <tr> <td>802.11n(HT40)/ac(VHT40)</td> <td>5755-5795</td> <td>2</td> </tr> <tr> <td>802.11 ac(VHT80)</td> <td>5775</td> <td>1</td> </tr> </tbody> </table>	WIFI 5G Band	Mode	Frequency Range(MHz)	Number of channels	UNII Band I	802.11a/n(HT20)/ac(VHT20)	5180-5240	4	802.11n(HT40)/ac(VHT40)	5190-5230	2	802.11 ac(VHT80)	5210	1	UNII Band II-A	802.11a/n(HT20)/ac(VHT20)	5260-5320	4	802.11n(HT40)/ac(VHT40)	5270-5310	2	802.11 ac(VHT80)	5290	1	UNII Band II-C	802.11a/n(HT20)/ac(VHT20)	5500-5700	11	802.11n(HT40)/ac(VHT40)	5510-5670	5	802.11 ac(VHT80)	5530-5610	2	UNII Band III	802.11a/n(HT20)/ac(VHT20)	5745-5825	5	802.11n(HT40)/ac(VHT40)	5755-5795	2	802.11 ac(VHT80)	5775	1
	WIFI 5G Band	Mode	Frequency Range(MHz)	Number of channels																																									
	UNII Band I	802.11a/n(HT20)/ac(VHT20)	5180-5240	4																																									
		802.11n(HT40)/ac(VHT40)	5190-5230	2																																									
		802.11 ac(VHT80)	5210	1																																									
	UNII Band II-A	802.11a/n(HT20)/ac(VHT20)	5260-5320	4																																									
		802.11n(HT40)/ac(VHT40)	5270-5310	2																																									
		802.11 ac(VHT80)	5290	1																																									
	UNII Band II-C	802.11a/n(HT20)/ac(VHT20)	5500-5700	11																																									
		802.11n(HT40)/ac(VHT40)	5510-5670	5																																									
		802.11 ac(VHT80)	5530-5610	2																																									
	UNII Band III	802.11a/n(HT20)/ac(VHT20)	5745-5825	5																																									
802.11n(HT40)/ac(VHT40)		5755-5795	2																																										
802.11 ac(VHT80)		5775	1																																										
<b>Transmit Power Max</b>	14.35 dBm for UNII Band II-A 14.36 dBm for UNII Band II-C																																												
<b>Device type</b>	Client Without Radar Detection																																												
<b>Antenna port</b>	2																																												
<b>TPC function</b>	<input type="checkbox"/> Applicable <input checked="" type="checkbox"/> Not Applicable																																												
<b>Antenna Gain</b>	3.79dBi for U-NII-1 3.88dBi for U-NII-2A 3.79dBi for U-NII-2C																																												
<b>Directional Gain</b>	6.80 dBi for U-NII-1 6.89 dBi for U-NII-2A 7.15 dBi for U-NII-2C																																												
<b>Power supply</b>	DC 5V from USB																																												

**Note:** for more details, please refer to the User's manual of the EUT.

**3. SUMMARY OF TEST RESULT**

<b>FCC Part Clause</b>	<b>Test Parameter</b>	<b>Verdict</b>	<b>Remark</b>
15.407 (h) (i) (j)	Dynamic Frequency Selection	PASS	
NOTE1: N/A (Not Applicable) NOTE2: According to FCC OET KDB 905462 D02 UNII DFS Compliance Procedures New Rules v02, In addition, the radiated test is also performed to ensure the emissions emanating from the device cabinet also comply with the applicable limits.			

#### 4. TEST METHODOLOGY

##### 4.1 GENERAL DESCRIPTION OF APPLIED STANDARDS

According to its specifications, the EUT must comply with the requirements of the following standards:  
 FCC-13-22  
 FCC 47 CFR Part 15, Subpart E  
 FCC KDB 905462 D02 UNII DFS Compliance Procedures New Rules v02

##### 4.2 MEASUREMENT EQUIPMENT USED

EQUIPMENT TYPE	MFR	MODEL NUMBER	SERIAL NUMBER	LAST CAL.	Due Cal.
Vector Signal Generator	Agilent	N5182B	My53050553	05/20/2018	05/19/2019
Analog Signal Generator	Agilent	N5171B	My53050878	05/20/2018	05/19/2019
Signal Analyzer	Agilent	N9010A	My53470879	05/20/2018	05/19/2019
Power Analyzer	Agilent	PS-X10-100	N/A	05/20/2018	05/19/2019
Test Accessories	Agilent	PS-X10-100	N/A	05/20/2018	05/19/2019

**Remark:** Each piece of equipment is scheduled for calibration once a year.

##### 4.3 DESCRIPTION OF TEST MODES

The EUT has been tested under its typical operating condition.

The EUT configuration for testing is installed on RF field strength measurement to meet the Commissions requirement and operating in a manner which intends to maximize its emission characteristics in a continuous normal application.

The Transmitter was operated in the normal operating mode. The TX frequency was fixed which was for the purpose of the measurements.

Test of channel included the lowest and middle and highest frequency to perform the test, then record on this report.

Those data rates (802.11a: 6 Mbps; 802.11n (HT20): MCS0; 802.11n (HT20): MCS7; 802.11n (HT40): MCS0; 802.11n (HT40): MCS7; 802.11ac (HT20): MCS0; 802.11ac (HT20): MCS7; 802.11ac (HT40): MCS0; 802.11ac (HT40): MCS7; 802.11ac (HT80): MCS0; 802.11ac (HT80): MCS7;) were used for all test.

Pre-defined engineering program for regulatory testing used to control the EUT for staying in continuous transmitting and receiving mode is programmed.

Wifi 5G with UNII Band II-A

Frequency and Channel list for 802.11a/n(HT20)/ac(VHT20):

Channel	Frequency (MHz)	Channel	Frequency (MHz)	Channel	Frequency (MHz)
52	5260	60	5300		
56	5280	64	5320		

Frequency and Channel list for 802.11n(VHT40)/ac(VHT40):

Channel	Frequency (MHz)	Channel	Frequency (MHz)	Channel	Frequency (MHz)
54	5270				
62	5310				

Frequency and Channel list for 802.11ac(VHT80):

Channel	Frequency (MHz)	Channel	Frequency (MHz)	Channel	Frequency (MHz)
58	5290				

**Test** Frequency and Channel for 802.11a/n(HT20)/ac(VHT20):

Lowest Frequency		Middle Frequency		Highest Frequency	
Channel	Frequency (MHz)	Channel	Frequency (MHz)	Channel	Frequency (MHz)
52	5260	56	5280	64	5320

**Test** Frequency and channel for 802.11n(HT40)/ac(VHT40):

Lowest Frequency		Middle Frequency		Highest Frequency	
Channel	Frequency (MHz)	Channel	Frequency (MHz)	Channel	Frequency (MHz)
54	5270	N/A	N/A	62	5310

**Test** Frequency and channel for 802.11ac(VHT80):

Lowest Frequency		Middle Frequency		Highest Frequency	
Channel	Frequency (MHz)	Channel	Frequency (MHz)	Channel	Frequency (MHz)
58	5290	N/A	N/A	N/A	N/A

Wifi 5G with UNII Band II-C

Frequency and Channel list for 802.11a/n(HT20)/ac(VHT20):

Channel	Frequency (MHz)	Channel	Frequency (MHz)	Channel	Frequency (MHz)
100	5500	116	5580	132	5660
104	5520	120	5600	136	5680
108	5540	124	5620	140	5700
112	5560	128	5640		

Frequency and Channel list for 802.11n(VHT40)/ac(VHT40):

Channel	Frequency (MHz)	Channel	Frequency (MHz)	Channel	Frequency (MHz)
102	5510	126	5630		
110	5550	134	5670		
118	5590				

Frequency and Channel list for 802.11ac(VHT80):

Channel	Frequency (MHz)	Channel	Frequency (MHz)	Channel	Frequency (MHz)
106	5530				
122	5610				

**Test** Frequency and Channel for 802.11a/n(HT20)/ac(VHT20):

Lowest Frequency		Middle Frequency		Highest Frequency	
Channel	Frequency (MHz)	Channel	Frequency (MHz)	Channel	Frequency (MHz)
100	5500	120	5600	140	5700

**Test** Frequency and channel for 802.11n(VHT40)/ac(VHT40):

Lowest Frequency		Middle Frequency		Highest Frequency	
Channel	Frequency (MHz)	Channel	Frequency (MHz)	Channel	Frequency (MHz)
102	5510	118	5590	134	5670

**Test** Frequency and channel for 802.11ac(VHT80):

Lowest Frequency		Middle Frequency		Highest Frequency	
Channel	Frequency (MHz)	Channel	Frequency (MHz)	Channel	Frequency (MHz)
106	5530	N/A	N/A	122	5610



## 5. FACILITIES AND ACCREDITATIONS

### 5.1 FACILITIES

All measurement facilities used to collect the measurement data are located at

Bldg 69, Majialong Industry Zone District, Nanshan District, Shenzhen, China

The sites are constructed in conformance with the requirements of ANSI C63.7, ANSI C63.4 and CISPR Publication 22.

### 5.2 EQUIPMENT

Radiated emissions are measured with one or more of the following types of linearly polarized antennas: tuned dipole, biconical, log periodic, bi-log, and/or ridged waveguide, horn. Spectrum analyzers with preselectors and quasi-peak detectors are used to perform radiated measurements.

Conducted emissions are measured with Line Impedance Stabilization Networks and EMI Test Receivers.

Calibrated wideband preamplifiers, coaxial cables, and coaxial attenuators are also used for making measurements.

All receiving equipment conforms to CISPR Publication 16-1, "Radio Interference Measuring Apparatus and Measurement Methods."

### 5.3 LABORATORY ACCREDITATIONS AND LISTINGS

Site Description

EMC Lab.

: Accredited by CNAS, 2016.10.24

The certificate is valid until 2022.10.28

The Laboratory has been assessed and proved to be in compliance with CNAS-CL01:2006 (identical to ISO/IEC 17025:2005)

The Certificate Registration Number is L2291.

Accredited by TUV Rheinland Shenzhen 2015.4

The Laboratory has been assessed according to the requirements ISO/IEC 17025.

Accredited by FCC, August 03, 2017

Designation Number: CN1204

Test Firm Registration Number: 882943

Accredited by A2LA, July 31, 2017

The Certificate Registration Number is 4321.01.

Accredited by Industry Canada, November 29, 2012

The Certificate Registration Number is 4480A.

Name of Firm

: EMTEK(SHENZHEN) CO., LTD..

Site Location

: Bldg 69, Majialong Industry Zone,  
Nanshan District, Shenzhen, Guangdong, China

## 6. SETUP OF EQUIPMENT UNDER TEST

### 6.1 SETUP CONFIGURATION OF EUT

#### Master Modes

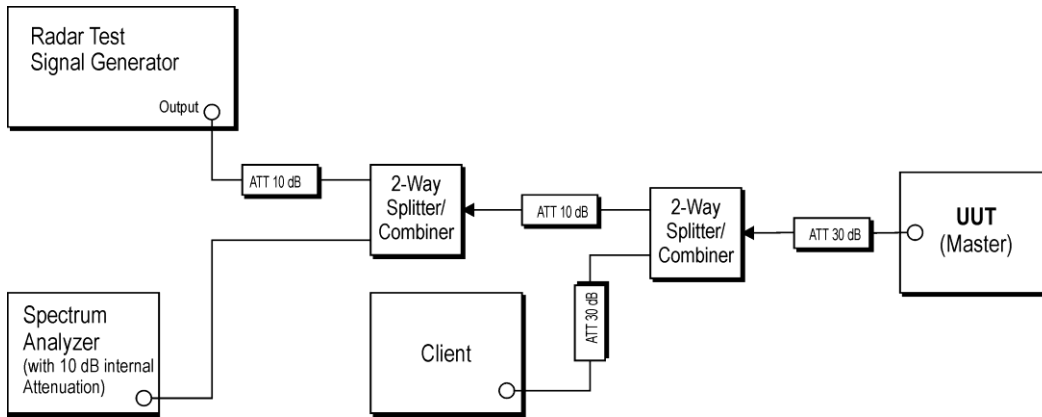

#### Slave Mode

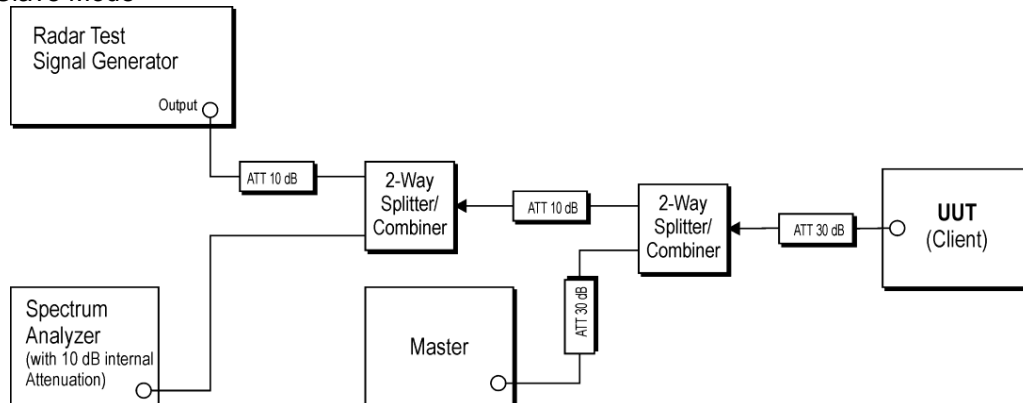

### 6.2 CALIBRATION OF DFS DETECTION THRESHOLD LEVEL:

A 50 ohm load is connected in place of the spectrum analyzer, and the spectrum analyzer is connected in place of the master device and the signal generator is set to CW mode. The amplitude of the signal generator is adjusted to yield a level of  $-62$  dBm as measured on the spectrum analyzer. Without changing any of the instrument settings, the spectrum analyzer is reconnected to the Common port of the Spectrum Analyzer Combiner/Divider. Measure the amplitude and calculate the difference from  $-62$  dBm. Adjust the Reference Level Offset of the spectrum analyzer to this difference. The spectrum analyzer displays the level of the signal generator as received at the antenna ports of the Master Device. The interference detection threshold may be varied from the calibrated value of  $-62$  dBm and the spectrum analyzer will still indicate the level as received by the Master Device. Set the signal generator to produce a radar waveform, trigger a burst manually and measure the level on the spectrum analyzer. Readjust the amplitude of the signal generator as required so that the peak level of the waveform is at a displayed level equal to the required or desired interference detection threshold. Separate signal generator amplitude settings are determined as required for each radar type.

**6.3 SUPPORT EQUIPMENT**

Item	Equipment	Mfr/Brand	Model/Type No.	Series No.	FCC ID
1.	Wireless Access Point	Cisco	AIR-CAP3702E-A-K9	FTX182276QD	LDK102087

Note: Software for transferring data between master and slave devices is TFGEN-1.00

**Notes:**

- 1. All the equipment/cables were placed in the worst-case configuration to maximize the emission during the test.*
- 2. Grounding was established in accordance with the manufacturer's requirements and conditions for the intended use.*

## 7. DYNAMIC FREQUENCY SELECTION REQUIREMENTS

### 7.1 APPLICABLE STANDARD

According to 15.407

### 7.2 CONFORMANCE LIMIT

The dynamic frequency selection requirement

Parameter	Value
Non-occupancy period	Minimum 30 minutes
Channel Availability Check Time	60 seconds
Channel Move Time	10 seconds See Note 1.
Channel Closing Transmission Time	200 milliseconds + an aggregate of 60 milliseconds over remaining 10 second period. See Notes 1 and 2.
U-NII Detection Bandwidth	Minimum 100% of the U-NII 99% transmission power bandwidth. See Note 3.
<p><b>Note 1:</b> <i>Channel Move Time</i> and the <i>Channel Closing Transmission Time</i> should be performed with Radar Type 0. The measurement timing begins at the end of the Radar Type 0 burst.</p> <p><b>Note 2:</b> The <i>Channel Closing Transmission Time</i> is comprised of 200 milliseconds starting at the beginning of the <i>Channel Move Time</i> plus any additional intermittent control signals required to facilitate a <i>Channel</i> move (an aggregate of 60 milliseconds) during the remainder of the 10 second period. The aggregate duration of control signals will not count quiet periods in between transmissions.</p> <p><b>Note 3:</b> During the <i>U-NII Detection Bandwidth</i> detection test, radar type 0 should be used. For each frequency step the minimum percentage of detection is 90 percent. Measurements are performed with no data traffic.</p>	

The following table lists the DFS The detection threshold values

Maximum Transmit Power	Value (See Notes 1, 2, and 3)
EIRP $\geq$ 200 milliwatt	-64 dBm
EIRP < 200 milliwatt and power spectral density < 10 dBm/MHz	-62 dBm
EIRP < 200 milliwatt that do not meet the power spectral density requirement	-64 dBm
<p><b>Note 1:</b> This is the level at the input of the receiver assuming a 0 dBi receive antenna.</p> <p><b>Note 2:</b> Throughout these test procedures an additional 1 dB has been added to the amplitude of the test transmission waveforms to account for variations in measurement equipment. This will ensure that the test signal is at or above the detection threshold level to trigger a DFS response.</p> <p><b>Note3:</b> EIRP is based on the highest antenna gain. For MIMO devices refer to KDB Publication 662911 D01.</p>	

### 7.3 TEST CONFIGURATION

Conducted measurements shall be used for DFS test

**7.4 TEST PARAMETERS OF DFS TEST SIGNAL**

The following table lists the parameters of radar test signals

**Short Pulse Radar Test Waveforms**

Radar Type	Pulse Width (μsec)	PRI (μsec)	Number of Pulses	Minimum Percentage of Successful Detection	Minimum Number of Trials
0	1	1428	18	See Note 1	See Note 1
1	1	Test A: 15 unique PRI values randomly selected from the list of 23 PRI values in Table 5a	Roundup $\left\{ \begin{matrix} \left( \frac{1}{360} \right) \cdot \\ \left( \frac{19 \cdot 10^6}{PRI_{\mu sec}} \right) \end{matrix} \right\}$	60%	30
		Test B: 15 unique PRI values randomly selected within the range of 518-3066 μsec, with a minimum increment of 1 μsec, excluding PRI values selected in Test A			
2	1-5	150-230	23-29	60%	30
3	6-10	200-500	16-18	60%	30
4	11-20	200-500	12-16	60%	30
Aggregate (Radar Types 1-4)				80%	120
<b>Note 1:</b> Short Pulse Radar Type 0 should be used for the detection bandwidth test, channel move time, and channel closing time tests.					

**Long Pulse Radar Test Waveform**

Radar Type	Pulse Width (μsec)	Chirp Width (MHz)	PRI (μsec)	Number of Pulses per Burst	Number of Bursts	Minimum Percentage of Successful Detection	Minimum Number of Trials
5	50-100	5-20	1000-2000	1-3	8-20	80%	30

**Frequency Hopping Radar Test Waveform**

Radar Type	Pulse Width (μsec)	PRI (μsec)	Pulses per Hop	Hopping Rate (kHz)	Hopping Sequence Length (msec)	Minimum Percentage of Successful Detection	Minimum Number of Trials
6	1	333	9	0.333	300	70%	30

**7.5 TRANSMITTER OUTPUT POWER**

**Temperature:** 25°C

**Humidity:** 55 % RH

Mode	Band	Max Power	
		Conducted Output Power	E.I.R.P
802.11a	5250MHz-5350MHz	14.35dBm(27.22mW)	18.23dBm(66.53mW)
802.11a	5470MHz-5725MHz	14.36dBm (27.29mW)	18.15dBm (65.31mW)

## 7.6 OPERATION MODES AND REQUIREMENT TEST ITEMS

The manufacture shall state whether the EUT is capable of operating as a Master or a Slave modes,if the EUT is capable of operating in more than one operational mode then every operating mode shall be assessed separately.

Applicability of DFS Requirements Prior to Use of a Channel

Requirement	Operational Mode		
	Master	Client Without Radar Detection	Client With Radar Detection
Non-Occupancy Period	Yes	Not required	Yes
DFS Detection Threshold	Yes	Not required	Yes
Channel Availability Check Time	Yes	Not required	Not required
Uniform Spreading	Yes	Not required	Not required
U-NII Detection Bandwidth	Yes	Not required	Yes

Applicability of DFS requirements during normal operation

Requirement	Operational Mode		
	Master	Client Without Radar Detection	Client With Radar Detection
DFS Detection Threshold	Yes	Not required	Yes
Channel Closing Transmission Time	Yes	Yes	Yes
Channel Move Time	Yes	Yes	Yes
U-NII Detection Bandwidth	Yes	Not required	Yes

## 7.7 TEST PROCEDURE

According to KDB 905462 D02v02 Section 7.

**8. TEST RESULT**

**8.1 DETAILED TEST RESULTS**

Clause	MODES	Test Parameter	Remark	Verdict
15.407	<input type="checkbox"/> Master	DFS Detection Threshold	N/A	N/A
15.407		Channel Availability Check Time	N/A	N/A
15.407		Channel Move Time	N/A	N/A
15.407		Channel Closing Transmission Time	N/A	N/A
15.407		Non-Occupancy Period	N/A	N/A
15.407		Uniform Spreading	N/A	N/A
15.407		U-NII Detection Bandwidth	N/A	N/A
15.407	<input checked="" type="checkbox"/> Slave	Radar Detection Threshold	N/A	N/A
15.407		Channel Move Time	Applicable	PASS
15.407		Channel Closing Transmission Time	Applicable	PASS
15.407		Non-Occupancy Period	N/A	N/A
15.407		U-NII Detection Bandwidth	N/A	N/A



## 8.2 RADAR WAVEFORM

Calibration:

Note: Maximum Transmit Power is less than 200 mW, so detection threshold level is -62dBm.

The 801.11ac(VHT80MHz) have been tested, and the result have been recorded in the below page.

## 8.3 TEST RESULTS

Items	Frequency(MHz)	Test Value(s)	Limit(s)	Verdict
Channel Move Time	5290	0.6187	10	PASS
Channel Closing Transmission Time		0.0026	0.26	PASS
Channel Move Time	5530	0.5602	10	PASS
Channel Closing Transmission Time		0.0022	0.26	PASS

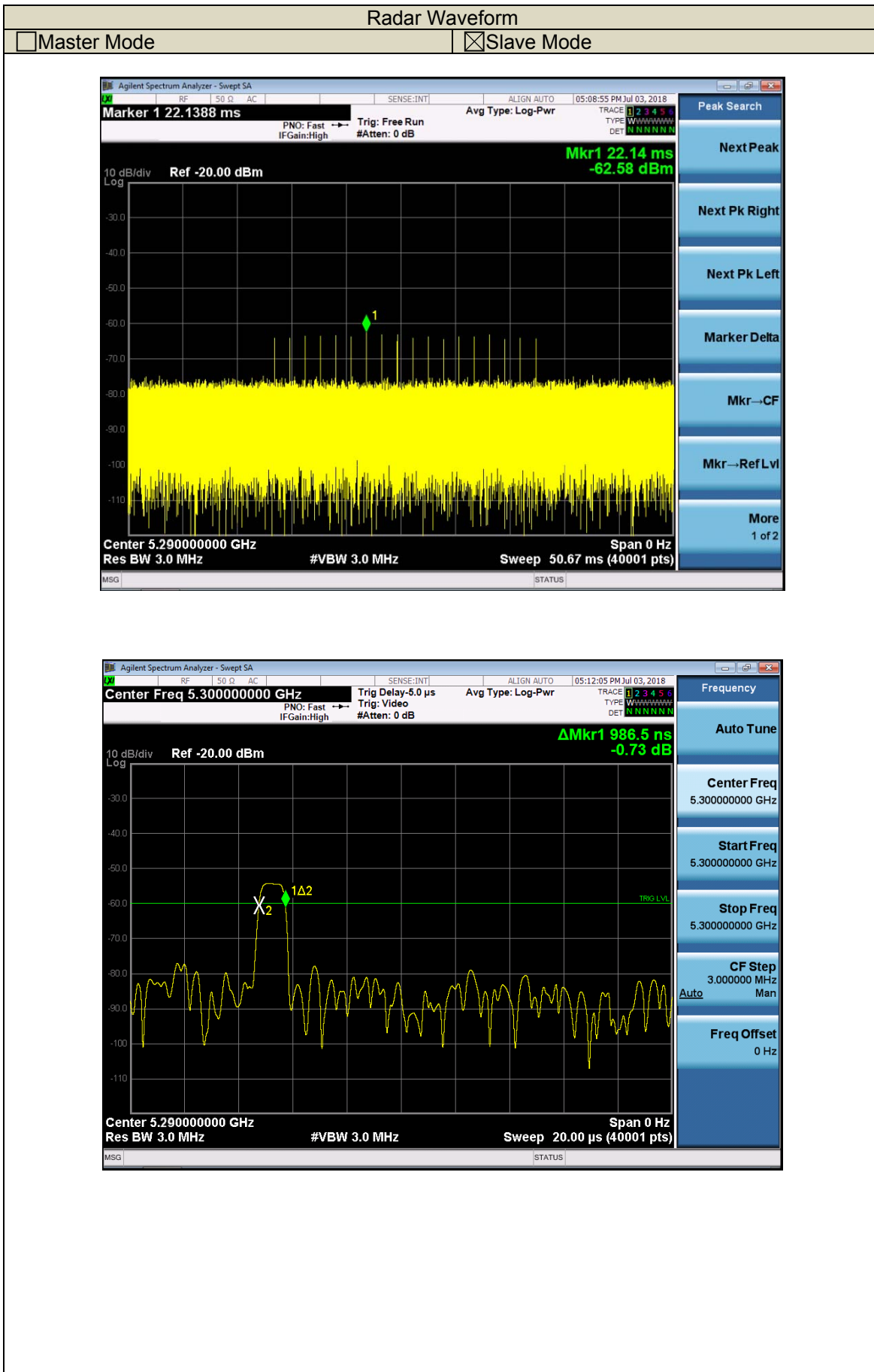

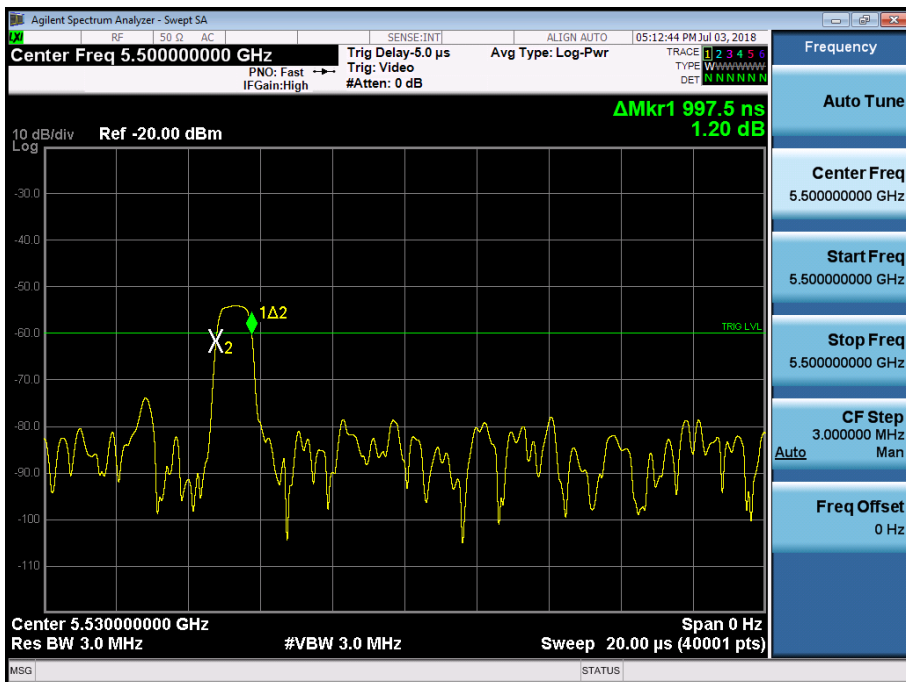
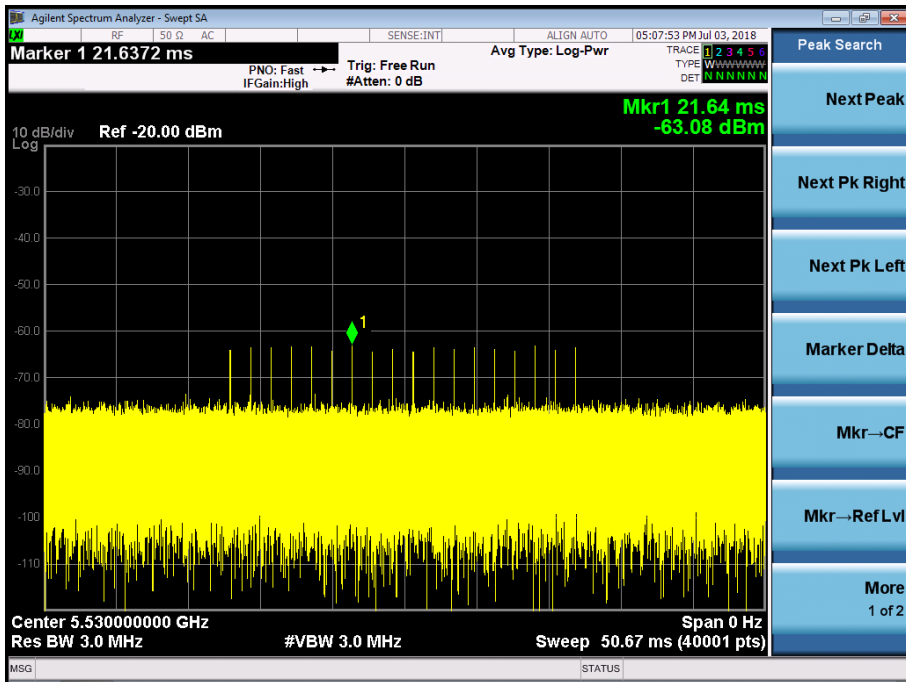

**8.4 IN-SERVICE MONITORING**

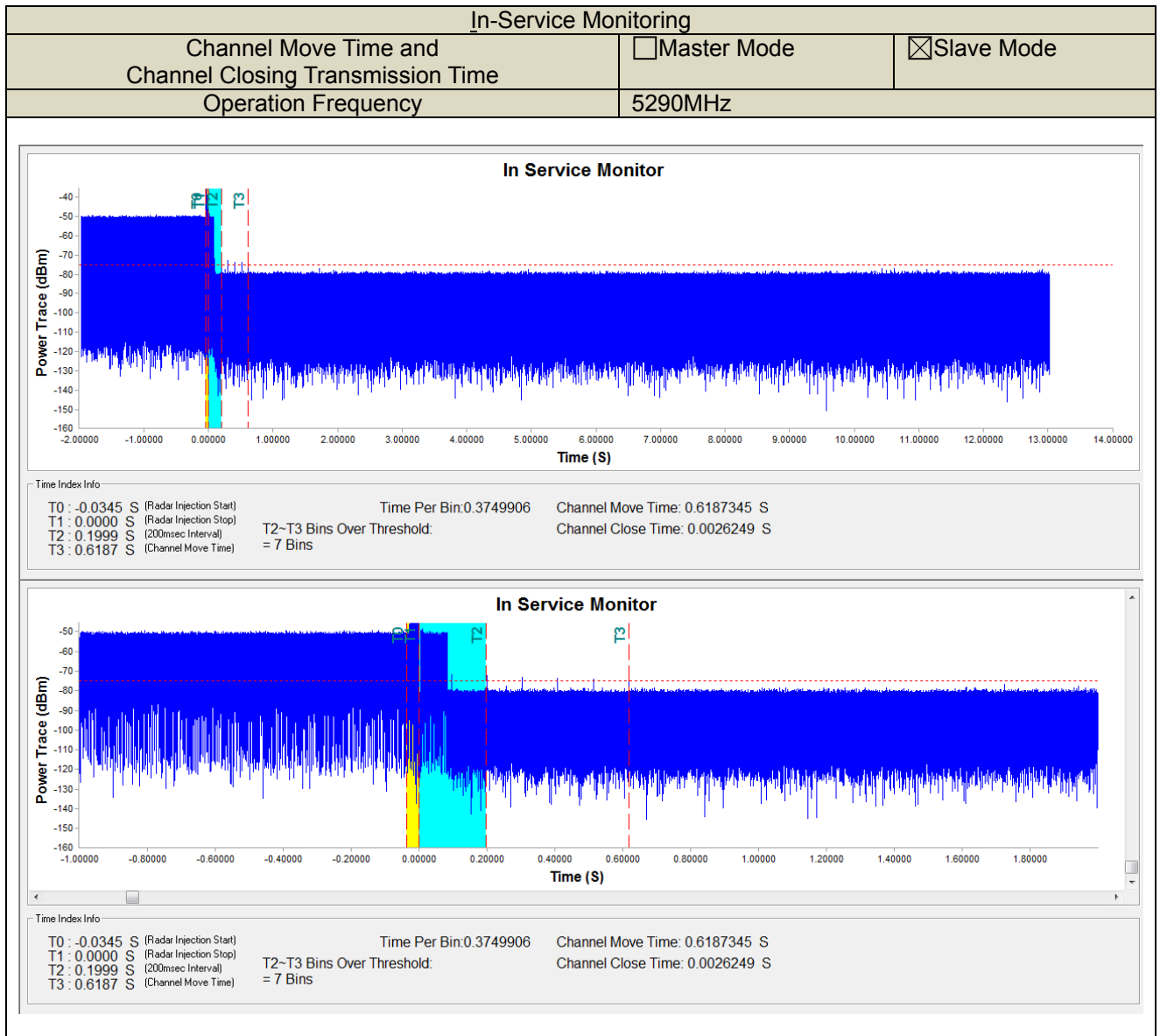

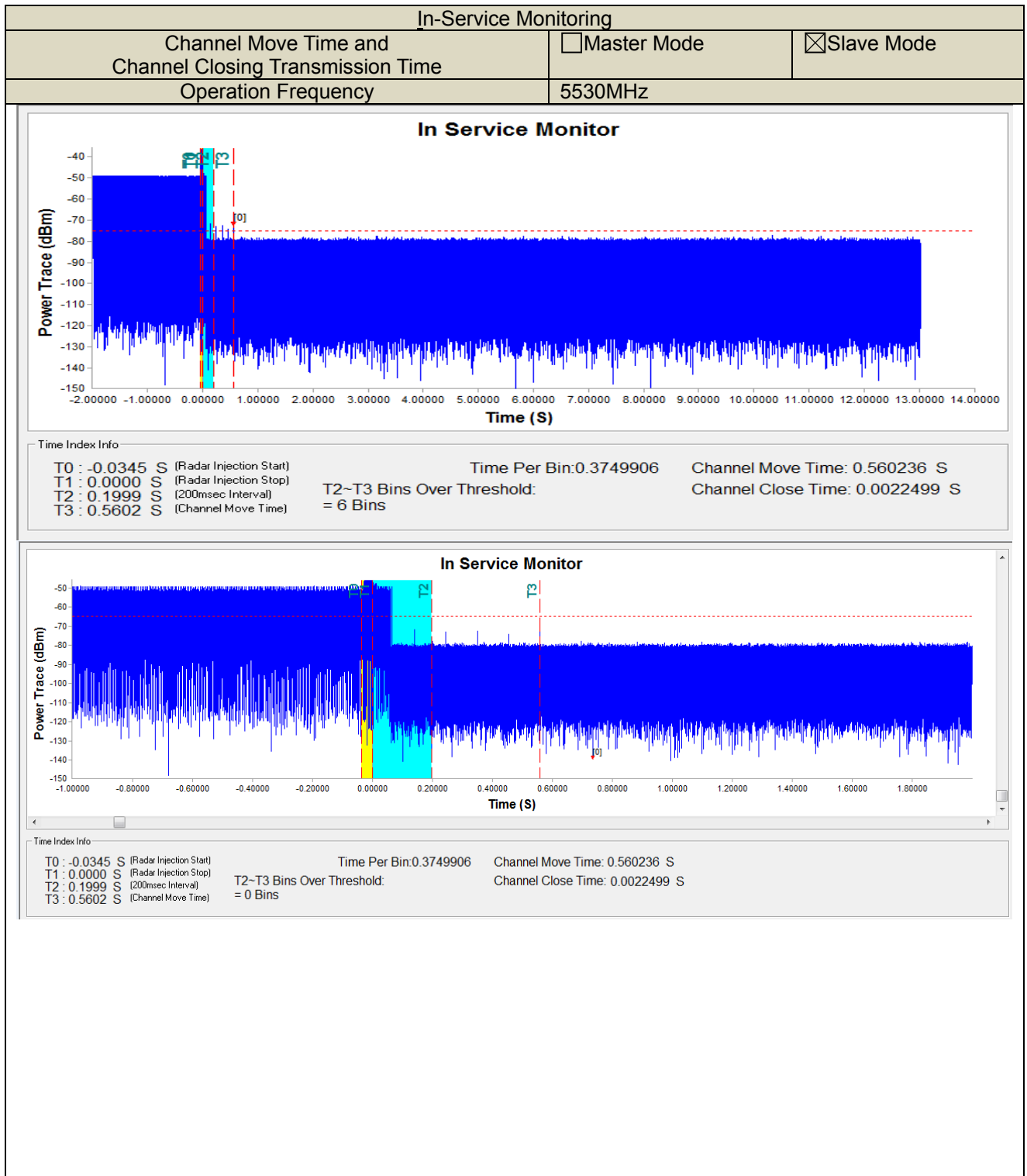

**TEST PHOTOGRAPHS**



End of Report