

承认书

Acknowledgment Letter

Supplier Name: FN-LINK TECHNOLOGY Ltd.

Supplier Address: Office Address: 14th Floor, Block B, Phoenix Zhigu, No.50 Tiezai Road, Gongle Community, Xixiang Street, Baoan District, Shenzhen, China 518000

Supplier Factory: Factory address: No.8, Litong Road, Liuyang Economic & Technical Development Zone, Changsha, Hunan, China 41032

Phone number: 86-755-2955-8186
website: www.fn-link.com

antenna testing

Customer	
Project Name	6220T-IF
Customer NO.	
specification	6220T-IF PCB Antenna
Supplier NO.	
Specification NO.	
Write by	Pan Yilin
REV.	Ver.1
Date	2024-4-22
Note	

1. Recognition Letter Project Table (Index)

Number	content	Page number
–	Acknowledgment Letter Cover	one
–	Antenna test report	two
–	Version change record	three
one	Confirmation Letter Project Table	four
two	Test equipment and conditions	five
three	Prototype structure specification	six
four	Finished antenna diagram	seven
five	S11	eight
six	Gain/Efficiency/3D Graph	nine -ten
seven	packing	eleven

(Test Equipment & Conditions)

1.1 . Network Analyzers : KEYSIGHT P5002A
 1.2 . Communications Test Set: R&S CMW 500

1.3 . 3D Chamber Test System: (24 probe testing system)

1. Testing principle diagram of microwave anechoic chamber

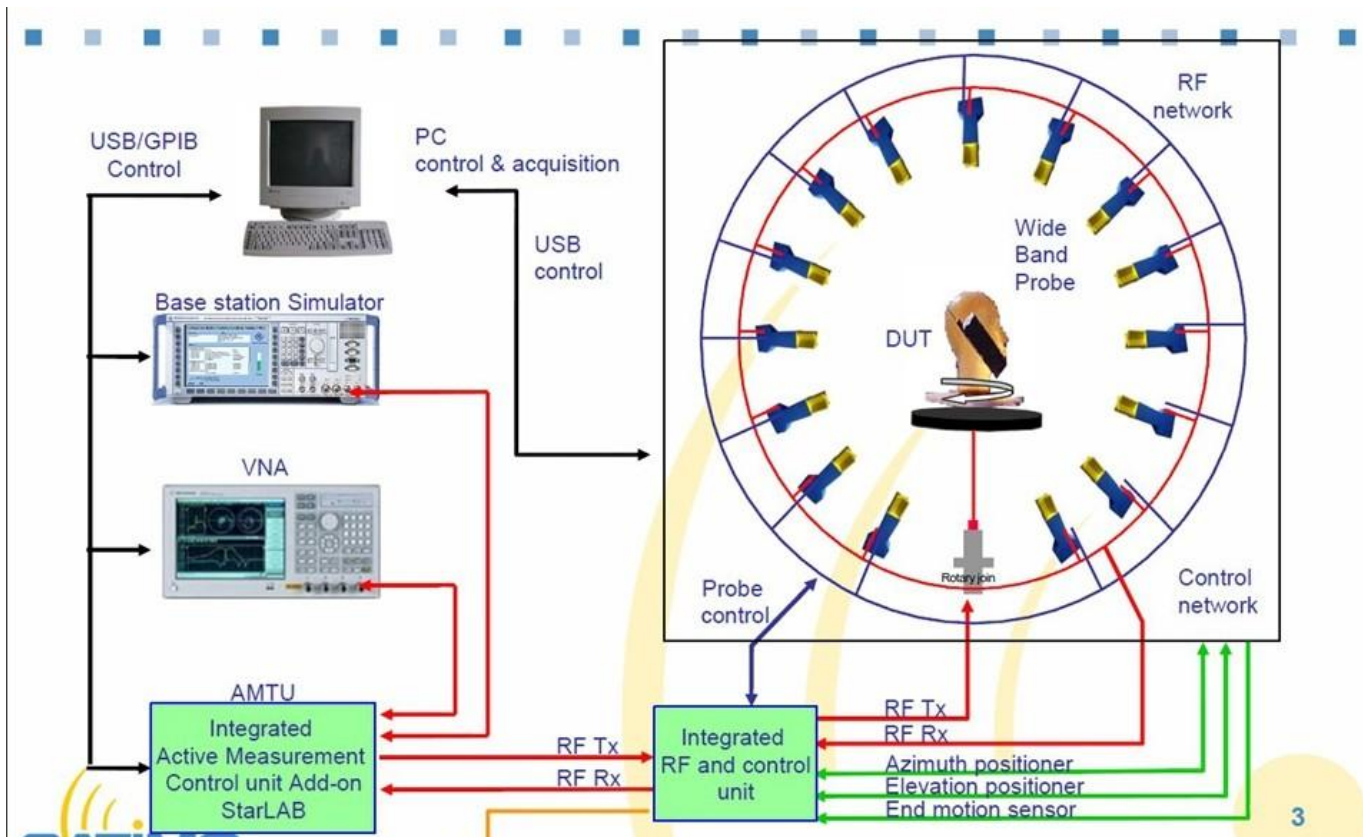

2. Explanation.

This report summarizes the electrical performance results of the antenna for the project, including the S11 parameters, Gain, and Efficiency of the antenna

catalogue

1. Complete machine description
2. Debugging data report
3. Test data



Finished antenna diagram

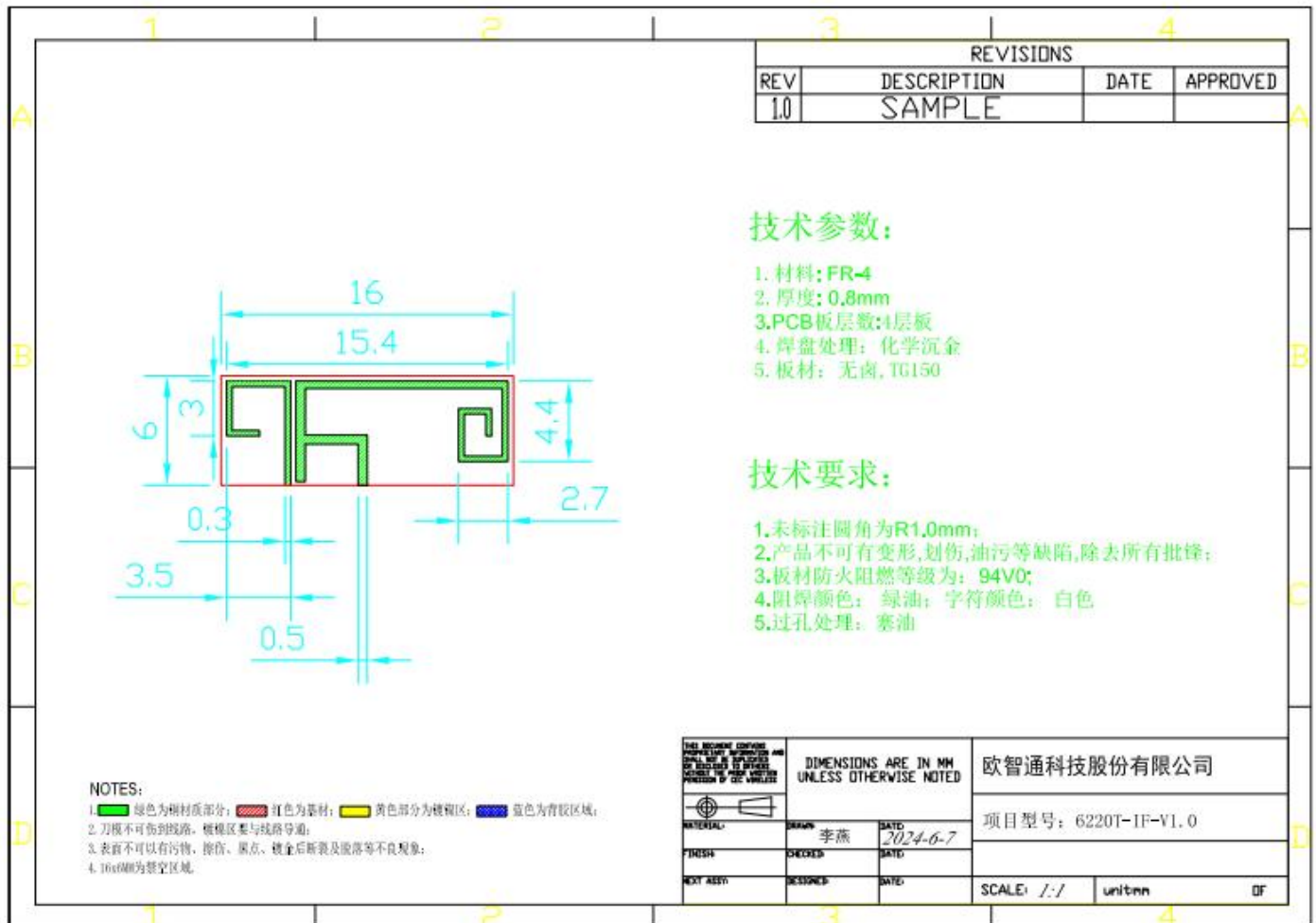

antenna S11



Test Items	standard	Frequency					
		2412	2442	2472	Ch5180	Ch5500	Ch5825
S11 RL(dB)		-10.98	-22.05	-10.14	-13.26	-13.29	-13.10

Frequency/Mhz	MaxGain/dBi	Efficiency / %
2400	0.38	44.98
2410	0.55	47.32
2420	0.64	449.55
2430	0.58	51.05
2440	0.54	52.6
2450	0.31	52.12
2460	0.08	49.32
2470	-0.02	47.1
2480	0	46.24
2490	-0.17	43.55
2500	-0.42	40.27
5000	0.79	36.73
5100	1.74	42.46
5200	1.34	38.73
5300	1.75	42.95
5400	2.36	44.06
5500	2.07	42.07
5600	2.13	41.21
5700	2.63	42.46
5800	2.27	42.46
5900	1.41	35.81

2400-2500 antenna Apple diagram Direction diagram

ZOX

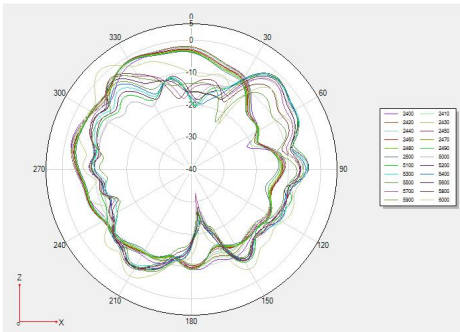

ZOY

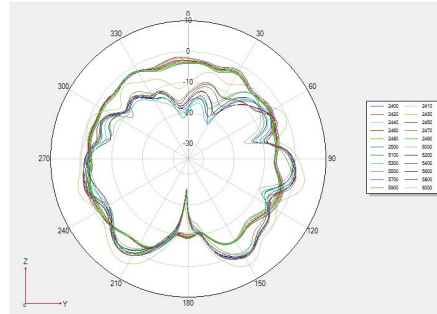

XOY

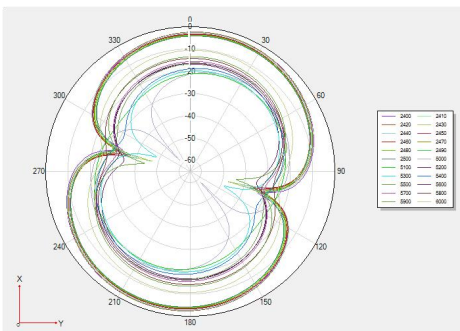

3D

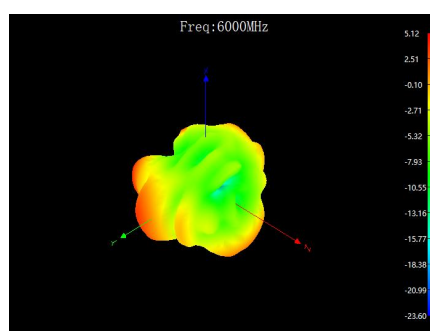
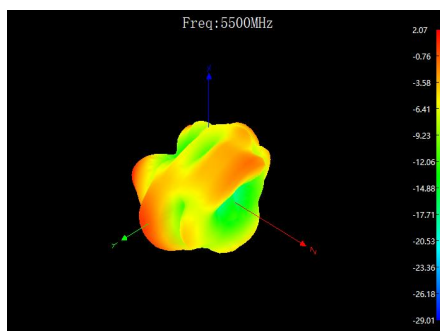
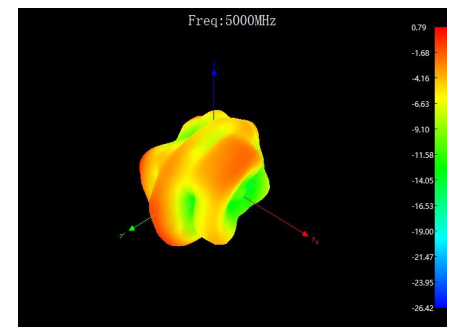
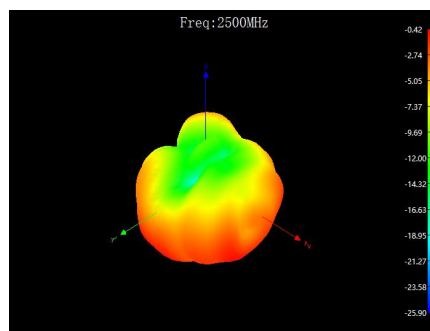
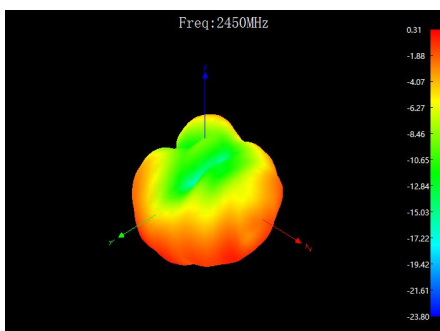
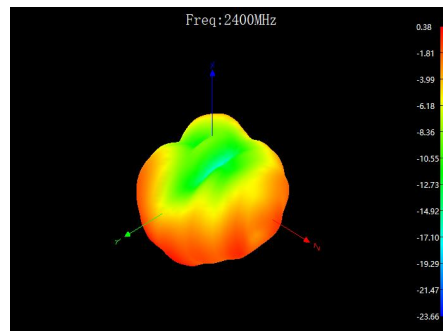

packing

产品包装规范 PACKING CRITERION

Date: 2023.10.13

Page: 1 of 1

Part Number : ANTRR-004113L195MMIX

Revision : A

Name: 2.4GHz Antenna

Customer : ALL

1.

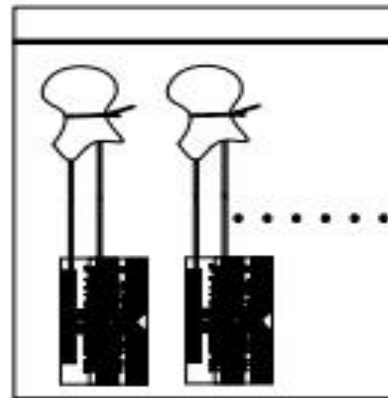

200PCS/PE BAG
R-NIP-BAG-220150



2. PACKING

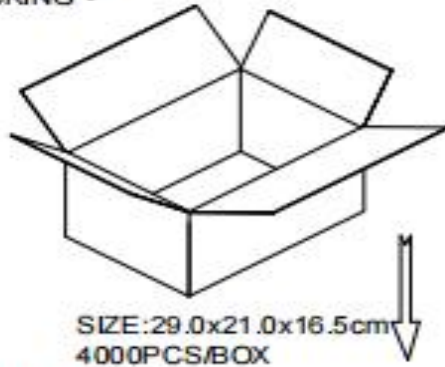

Pearl cotton : 1pcs/BOX

3. SEALING

