



ALS6A-E

Hardware Interface Description

Version: 02.011b

DocId: ALS6A-E_HID_v02.011b

Status: Confidential / Released

Date: 2024-05-14

DISCLAIMER

Kontron would like to point out that the information contained in this document may be subject to alteration, particularly as a result of the constant upgrading of Kontron products. This document does not entail any guarantee on the part of Kontron with respect to technical processes described in the document or any product characteristics set out in the document. Kontron assumes no responsibility or liability for the use of the described product(s), conveys no license or title under any patent, copyright or mask work rights to these products and makes no representations or warranties that these products are free from patent, copyright or mask work right infringement unless otherwise specified. Applications that are described in this document are for illustration purposes only. Kontron makes no representation or warranty that such application will be suitable for the specified use without further testing or modification. Kontron expressly informs the user that this document only contains a general description of processes and instructions which may not be applicable in every individual case. In cases of doubt, please contact Kontron.

This document is protected by copyright. All rights are reserved by Kontron. No part of this document may be reproduced, transmitted, transcribed, stored in a retrieval system, or translated into any language or computer language, in any form or by any means (electronic, mechanical, photocopying, recording, or otherwise), without the express written permission of Kontron. Kontron points out that the information contained in this document is constantly being updated in line with the technical alterations and improvements made by Kontron to the products and thus this document only reflects the technical status of the products by Kontron at the time of publishing.

Brand and product names are trademarks or registered trademarks of their respective owners.

© 2024 by Kontron Europe GmbH

Kontron Europe GmbH
Gutenbergstraße 2
85737 Ismaning
Germany
www.kontron.com

Contents

Document History	7
1/ Introduction	9
1.1. Supported Products	9
1.2. Related Documents	9
1.3. Terms and Abbreviations	9
1.4. Regulatory and Type Approval Information	12
1.4.1. Directives and Standards	12
1.4.2. SAR requirements specific to portable mobiles	14
1.4.3. SELV Requirements	15
1.4.4. Safety Precautions	15
2/ Product Concept	16
2.1. Key Features at a Glance	16
2.2. ALS6A-E System Overview	18
2.3. Circuit Concept	19
3/ Application Interface	20
3.1. Operating Modes	21
3.2. Power Supply	22
3.2.1. Minimizing Power Losses	23
3.2.2. Monitoring Power Supply by AT Command	23
3.3. Power-Up / Power-Down Scenarios	24
3.3.1. Turn on ALS6A-E	24
3.3.2. Signal States after Startup	25
3.3.3. Turn off ALS6A-E Using AT Command	26
3.3.4. Turn off ALS6A-E Using IGT Line	27
3.3.5. Automatic Shutdown	27
3.3.5.1. Thermal Shutdown	27
3.3.5.2. Deferred Shutdown at Extreme Temperature Conditions	28
3.3.5.3. Undervoltage Shutdown	28
3.3.5.4. Overvoltage Shutdown	28
3.3.6. Turn off ALS6A-E in Case of Emergency	29
3.4. Power Saving	30
3.4.1. Power Saving while Attached to GSM Networks	30
3.4.2. Power Saving while Attached to WCDMA Networks	30
3.4.3. Power Saving while Attached to LTE Networks	31
3.5. USB Interface	32
3.6. UICC/SIM/USIM Interface	33
3.6.1. Enhanced ESD Protection for SIM Interface	34
3.7. Digital Audio Interface	35
3.7.1. Pulse Code Modulation Interface (PCM)	35
3.8. Analog-to-Digital Converter (ADC)	36
3.9. GPIO Interface	36
3.10. Control Signals	36
3.10.1. PWR_IND Signal	36
3.10.2. Behavior of the RING0 Line	36
4/ Antenna Interfaces	37
4.1. GSM/UMTS/LTE Antenna Interface	37
4.1.1. Antenna Installation	38
4.1.2. RF Line Routing Design	39
4.1.2.1. Line Arrangement Examples	39
4.1.2.2. Routing Example	41
4.1.3. RF Antenna Diagnostic	42
5/ Electrical, Reliability and Radio Characteristics	45
5.1. Absolute Maximum Ratings	45
5.2. Operating Temperatures	45
5.3. Storage Conditions	46
5.4. Reliability Characteristics	47
5.4.1. Bending Tests	48
5.5. Pad Assignment and Signal Description	49
5.6. Power Supply Ratings	55
5.7. RF Antenna Interface Characteristics	58
5.8. Electrostatic Discharge	62

6/	Mechanics, Mounting and Packaging	63
	6.1. Mechanical Dimensions of ALS6A-E	63
	6.2. Mounting ALS6A-E onto the Application Platform.....	65
	6.2.1. SMT PCB Assembly.....	65
	6.2.1.1. Land Pattern and Stencil	65
	6.2.1.2. Board Level Characterization	67
	6.2.2. Moisture Sensitivity Level	67
	6.2.3. Soldering Conditions and Temperature.....	67
	6.2.3.1. Reflow Profile	67
	6.2.3.2. Maximum Temperature and Duration	68
	6.2.4. Durability and Mechanical Handling.....	69
	6.2.4.1. Storage Life	69
	6.2.4.2. Processing Life.....	69
	6.2.4.3. Baking.....	69
	6.2.4.4. Electrostatic Discharge	69
	6.3. Packaging	70
	6.3.1. Tape and Reel	70
	6.3.1.1. Orientation.....	70
	6.3.1.2. Barcode Label.....	71
	6.3.2. Shipping Materials	71
	6.3.2.1. Moisture Barrier Bag.....	71
	6.3.2.2. Transportation Box.....	73
7/	Sample Application	74
	7.1. Sample Circuit for Antenna Detection	76
8/	Reference Approval	79
	8.1. Reference Equipment for Type Approval.....	79
	8.2. Compliance with FCC Rules and Regulations	80
9/	Appendix	81
	9.1. List of Parts and Accessories	81
	9.2. Mounting Advice Sheet.....	83

Tables

Table 1: Directives.....	12
Table 2: Standards of North American type approval.....	12
Table 3: Standards of European type approval.....	12
Table 4: Requirements of quality.....	13
Table 5: Standards of the Ministry of Information Industry of the People’s Republic of China	13
Table 6: Toxic or hazardous substances or elements with defined concentration limits	13
Table 7: Overview of operating modes	21
Table 8: Signal states.....	25
Table 9: Temperature dependent behavior.....	27
Table 10: Signals of the SIM interface (SMT application interface)	33
Table 11: Overview of PCM pin functions.....	35
Table 12: Return loss in the active band	37
Table 13: Possible GPIOx and GPIOy signal states if used for antenna diagnosis.....	43
Table 14: Assured antenna diagnostic states.....	44
Table 15: GSM/UMTS/LTE antenna diagnostic decision threshold.....	44
Table 16: Absolute maximum ratings	45
Table 17: Board temperature.....	45
Table 18: Storage conditions.....	46
Table 19: Summary of reliability test conditions	47
Table 20: Overview: Pad assignments	49
Table 21: Signal description	52
Table 22: Voltage supply ratings	55
Table 23: Current consumption ratings	55
Table 24: RF Antenna interface GSM / UMTS/LTE (at operating temperature range)	58
Table 25: Electrostatic values.....	62
Table 26: Reflow temperature ratings	68
Table 27: Antenna diagnosis reference circuit - parts list.....	78
Table 28: List of parts and accessories.....	81
Table 29: Molex sales contacts (subject to change)	82
Table 30: Hirose sales contacts (subject to change)	82

Figures

Figure 1: ALS6A-E system overview	18
Figure 2: ALS6A-E block diagram.....	19
Figure 3: Decoupling capacitor(s) for BATT+.....	22
Figure 4: Power supply limits during transmit burst.....	23
Figure 5: Power-on with IGT	24
Figure 6: Signal states during turn-off procedure	26
Figure 7: Timing of IGT if used to switch off the module.....	27
Figure 8: Shutdown by EMERG_OFF signal	29
Figure 9: Power saving and paging in GSM networks.....	30
Figure 10: Power saving and paging in WCDMA networks.....	30
Figure 11: Power saving and paging in LTE networks	31
Figure 12: USB circuit	32
Figure 13: UICC/SIM/USIM interface	33
Figure 14: SIM interface - enhanced ESD protection	34
Figure 15: PCM timing short frame (master, 4096KHz).....	35
Figure 16: PWR_IND signal.....	36
Figure 17: Antenna pads (bottom view)	38
Figure 18: Embedded Stripline line arrangement.....	39
Figure 19: Micro-Stripline line arrangement samples.....	40
Figure 20: Routing to application's RF connector	41
Figure 21: ALS6A-E evaluation board layer table.....	41
Figure 22: Resistor measurement used for antenna detection	42
Figure 23: Basic layout sample for antenna detection.....	43
Figure 24: Bending test setup	48
Figure 25: ALS6A-E bottom view: Pad assignments.....	50
Figure 26: ALS6A-E top view: Pad assignments	51
Figure 27: ALS6A-E – top and bottom view.....	63
Figure 28: Dimensions of ALS6A-E (all dimensions in mm).....	64
Figure 29: Land pattern (top layer)	65
Figure 30: Recommended design for 110 micron thick stencil (top layer).....	66
Figure 31: Recommended design for 150 micron thick stencil (top layer).....	66
Figure 32: Reflow Profile	67
Figure 33: Carrier tape	70
Figure 34: Roll direction	70
Figure 35: Barcode label on tape reel	71
Figure 36: Moisture barrier bag (MBB) with imprint	71
Figure 37: Moisture Sensitivity Label	72
Figure 38: Humidity Indicator Card - HIC	73
Figure 39: ALS6A-E sample application.....	75
Figure 40: Antenna diagnosis - overview	76
Figure 41: Antenna diagnosis - antenna detection schematic.....	77
Figure 42: Reference equipment for type approval.....	79

Document History

Preceding document: "ALS6A-E Hardware Interface Description" Version 02.011a

New document: "ALS6A-E Hardware Interface Description" Version **02.011b**

Chapter	What is new
--	Updated layout (because of company name change).
1.4.1.	Updated some standards versions.
8.2.	Revised FCC identifier as well as ISED Certification Number.

Preceding document: "ALS6A-E Hardware Interface Description" Version 02.011

New document: "ALS6A-E Hardware Interface Description" Version 02.011a

Chapter	What is new
1.4.1.	Added Table 2 listing North American type approval standards.
1.4.2.	Revised section to include US markets.
8.2.	New section Compliance with FCC Rules and Regulations .

Preceding document: "ALS6A-E Hardware Interface Description" Version 01.714

New document: "ALS6A-E Hardware Interface Description" Version 02.011

Chapter	What is new
Throughout document	Added LTE 2100MHz (Bd1).
6.2.3.1.	Revised average ramp-down rate listed in Table 26 . Added note regarding reflow profile features and ratings listed in Table 26 .

Preceding document: "ALS6A-E Hardware Interface Description" Version 01.270

New document: "ALS6A-E Hardware Interface Description" Version 01.714

Chapter	What is new
3.3.1.	Added information on " ^SYSSTART " and " ^SYSSTART AIRPLANE " URCs.
3.5.	Revised information on SLEEP mode.

Preceding document: "ALS6A-E Hardware Interface Description" Version 01.262

New document: "ALS6A-E Hardware Interface Description" Version 01.270

Chapter	What is new
---	Version update.

Preceding document: "ALS6A-E Hardware Interface Description" Version 01.200a

New document: "ALS6A-E Hardware Interface Description" Version 01.262

Chapter	What is new
Throughout document	Added power saving (SLEEP mode) descriptions. Added host wakeup via RING0 line including Section 3.10.2 . Added PCM interface description and characteristics including Section 3.7 . STATUS line not available.
3.3.3.	Revised deregistration timing given in Figure 6 .
3.3.5.2.	New section Deferred Shutdown at Extreme Temperature Conditions .
3.4.3.	Completed section Power Saving while Attached to LTE Networks .

Chapter	What is new
3.5.	Added remark on SLEEP mode being only available while USB is disconnected.
5.4.1.	Completed section Bending Tests .
5.5.	Added remark to VUSB_IN signal form and level.
5.6.	Completed current consumption ratings for SLEEP mode and power reduction.
5.7.	Completed Table 24 listing RF interface characteristics.
6.2.	Added note regarding routing of signal tracks.
6.3.2.1.	Replaced humidity indicator card shown in Figure 38 .
5.6.	Added voice call current consumption ratings to Table 23 .
9.1.	Added Votronic handset for approval purposes.

Preceding document: "ALS6A-E Hardware Interface Description" Version 01.200

New document: "ALS6A-E Hardware Interface Description" Version 01.200a

Chapter	What is new
5.2.	Revised section.

New document: "ALS6A-E Hardware Interface Description" Version 01.200

Chapter	What is new
--	Initial document setup.

1/ Introduction

The document¹ describes the hardware of the ALS6A-E module, designed to connect to a cellular device application and the air interface. It helps you quickly retrieve interface specifications, electrical and mechanical details and information on the requirements to be considered for integrating further components.

1.1. Supported Products

This document applies to the following Kontron products:

- › ALS6A-E module

1.2. Related Documents

- [1] AT Command Set for your Kontron product
- [2] Release Notes for your Kontron product
- [3] Application Note 48: SMT Module Integration
- [4] Universal Serial Bus Specification Revision 2.0, April 27, 2000

1.3. Terms and Abbreviations

Abbreviation	Description
ANSI	American National Standards Institute
ARP	Antenna Reference Point
CE	Conformité Européene (European Conformity)
CS	Coding Scheme
CS	Circuit Switched
CSD	Circuit Switched Data
DCS	Digital Cellular System
DL	Download
dnu	Do not use
DRX	Discontinuous Reception
DSB	Development Support Board
DTX	Discontinuous Transmission
EDGE	Enhanced Data rates for GSM Evolution
EGSM	Extended GSM
EMC	Electromagnetic Compatibility
ESD	Electrostatic Discharge
ETS	European Telecommunication Standard
ETSI	European Telecommunications Standards Institute
FDD	Frequency Division Duplex
GPRS	General Packet Radio Service
GSM	Global Standard for Mobile Communications
HiZ	High Impedance
HSDPA	High Speed Downlink Packet Access

¹ The document is effective only if listed in the appropriate Release Notes as part of the technical documentation delivered with your Kontron product.

Abbreviation	Description
I/O	Input/Output
IMEI	International Mobile Equipment Identity
ISO	International Standards Organization
ITU	International Telecommunications Union
kbits	kbits per second
LED	Light Emitting Diode
LGA	Land Grid Array
LTE	Long term evolution
MBB	Moisture barrier bag
Mbps	Mbits per second
MCS	Modulation and Coding Scheme
MIMO	Multiple Input Multiple Output
MLCC	Multi Layer Ceramic Capacitor
MO	Mobile Originated
MS	Mobile Station, also referred to as TE
MSL	Moisture Sensitivity Level
MT	Mobile Terminated
nc	Not connected
NTC	Negative Temperature Coefficient
PCB	Printed Circuit Board
PCL	Power Control Level
PCS	Personal Communication System, also referred to as GSM 1900
PD	Pull Down resistor
PDU	Protocol Data Unit
PS	Packet Switched
PSK	Phase Shift Keying
PU	Pull Up resistor
QAM	Quadrature Amplitude Modulation
R&TTE	Radio and Telecommunication Terminal Equipment
RF	Radio Frequency
rfu	Reserved for future use
ROPR	Radio Output Power Reduction
RTC	Real Time Clock
Rx	Receive Direction
SAR	Specific Absorption Rate
SELV	Safety Extra Low Voltage
SIM	Subscriber Identification Module
SMD	Surface Mount Device
SMS	Short Message Service
SMT	Surface Mount Technology

Abbreviation	Description
SRAM	Static Random Access Memory
SRB	Signalling Radio Bearer
TE	Terminal Equipment
TPC	Transmit Power Control
TS	Technical Specification
Tx	Transmit Direction
UL	Upload
UMTS	Universal Mobile Telecommunications System
URC	Unsolicited Result Code
USB	Universal Serial Bus
UICC	USIM Integrated Circuit Card
USIM	UMTS Subscriber Identification Module
WCDMA	Wideband Code Division Multiple Access

1.4. Regulatory and Type Approval Information

1.4.1. Directives and Standards

ALS6A-E has been designed to comply with the directives and standards listed below.

It is the responsibility of the application manufacturer to ensure compliance of the final product with all provisions of the applicable directives and standards as well as with the technical specifications provided in the "ALS6A-E Hardware Interface Description".

Table 1: Directives



99/05/EC	Directive of the European Parliament and of the council of 9 March 1999 on radio equipment and telecommunications terminal equipment and the mutual recognition of their conformity (in short referred to as R&TTE Directive 1999/5/EC) The product is labeled with the CE conformity mark 
ECE-R 10	Economic Commission for Europe (ECE) Regulation No. 10: Uniform provisions concerning the approval of vehicles with regard to electromagnetic compatibility
2002/95/EC (RoHS 1) 2011/65/EC (RoHS 2)	Directive of the European Parliament and of the Council of 27 January 2003 (and revised on 8 June 2011) on the restriction of the use of certain hazardous substances in electrical and electronic equipment (RoHS) 

Table 2: Standards of North American type approval

CFR Title 47	Code of Federal Regulations, Part 27; US Equipment Authorization FCC
OET Bulletin 65 (Edition 97-01)	Evaluating Compliance with FCC Guidelines for Human Exposure to Radiofrequency Electromagnetic Fields

Table 3: Standards of European type approval

3GPP TS 51.010-1	Digital cellular telecommunications system (Release 7); Mobile Station (MS) conformance specification;
ETSI EN 301 511 V9.0.2	Global System for Mobile communications (GSM); Harmonized standard for mobile stations in the GSM 900 and DCS 1800 bands covering essential requirements under article 3.2 of the R&TTE directive (1999/5/EC)
GCF-CC V3.48	Global Certification Forum - Certification Criteria
ETSI EN 301 489-01 V2.2.3	Electromagnetic Compatibility and Radio spectrum Matters (ERM); Electromagnetic Compatibility (EMC) standard for radio equipment and services; Part 1: Common Technical Requirements
ETSI EN 301 489-07 V1.3.1	Electromagnetic Compatibility and Radio spectrum Matters (ERM); Electromagnetic Compatibility (EMC) standard for radio equipment and services; Part 7: Specific conditions for mobile and portable radio and ancillary equipment of digital cellular radio telecommunications systems (GSM and DCS)
ETSI EN 301 489-24 V1.5.1	Electromagnetic Compatibility and Radio spectrum Matters (ERM); Electromagnetic Compatibility (EMC) standard for radio equipment and services; Part 24: Specific conditions for IMT-2000 CDMA Direct Spread (UTRA) for Mobile and portable (UE) radio and ancillary equipment
EN 301 908-01 V15.2.1	Electromagnetic compatibility and Radio spectrum Matters (ERM); Base Stations (BS) and User Equipment (UE) for IMT-2000 Third Generation cellular networks; Part 1: Harmonized EN for IMT-2000, introduction and common requirements of article 3.2 of the R&TTE Directive
EN 301 908-02 V13.1.1	Electromagnetic compatibility and Radio spectrum Matters (ERM); Base Stations (BS) and User Equipment (UE) for IMT-2000 Third Generation cellular networks; Part 2: Harmonized EN for IMT-2000, CDMA Direct Spread (UTRA FDD) (UE) covering essential requirements of article 3.2 of the R&TTE Directive
EN 301 908-13 V13.2.1	IMT cellular networks; Harmonized EN covering the essential requirements of article 3.2 of the R&TTE Directive; Part 13: Evolved Universal Terrestrial Radio Access (E-UTRA) User Equipment (UE)

Table 3: Standards of European type approval

EN 300 440-02 V1.3.1	Electromagnetic compatibility and Radio spectrum Matters (ERM); Short range devices; Radio equipment to be used in the 1 GHz to 40 GHz frequency range; Part 2: Harmonized EN covering essential requirements of article 3.2 of the R&TTE Directive
EN 62311:2008	Assessment of electronic and electrical equipment related to human exposure restrictions for electromagnetic fields (0 Hz - 300 GHz)
IEC/EN 60950-1:2006+ A11:2009+A1:2010+ A12:2011	Safety of information technology equipment

Table 4: Requirements of quality

IEC 60068	Environmental testing
DIN EN 60529	IP codes

Table 5: Standards of the Ministry of Information Industry of the People's Republic of China

SJ/T 11363-2006	"Requirements for Concentration Limits for Certain Hazardous Substances in Electronic Information Products" (2006-06).
SJ/T 11364-2006	<p>"Marking for Control of Pollution Caused by Electronic Information Products" (2006-06).</p> <p>According to the "Chinese Administration on the Control of Pollution caused by Electronic Information Products" (ACPEIP) the EPUP, i.e., Environmental Protection Use Period, of this product is 20 years as per the symbol shown here, unless otherwise marked. The EPUP is valid only as long as the product is operated within the operating limits described in the Hardware Interface Description.</p> <p>Please see Table 6 for an overview of toxic or hazardous substances or elements that might be contained in product parts in concentrations above the limits defined by SJ/T 11363-2006.</p>

**Table 6: Toxic or hazardous substances or elements with defined concentration limits**

部件名称 Name of the part	有毒有害物质或元素 Hazardous substances					
	铅 (Pb)	汞 (Hg)	镉 (Cd)	六价铬 (Cr(VI))	多溴联苯 (PBB)	多溴二苯醚 (PBDE)
金属部件 (Metal Parts)	○	○	○	○	○	○
电路模块 (Circuit Modules)	X	○	○	○	○	○
电缆及电缆组件 (Cables and Cable Assemblies)	○	○	○	○	○	○
塑料和聚合物部件 (Plastic and Polymeric parts)	○	○	○	○	○	○

O:
表示该有毒有害物质在该部件所有均质材料中的含量均在SJ/T11363-2006 标准规定的限量要求以下。
Indicates that this toxic or hazardous substance contained in all of the homogeneous materials for this part is below the limit requirement in SJ/T11363-2006.

X:
表示该有毒有害物质至少在该部件的某一均质材料中的含量超出SJ/T11363-2006标准规定的限量要求。
Indicates that this toxic or hazardous substance contained in at least one of the homogeneous materials used for this part *might exceed* the limit requirement in SJ/T11363-2006.

1.4.2. SAR requirements specific to portable mobiles

Mobile phones, PDAs or other portable transmitters and receivers incorporating a GSM module must be in accordance with the guidelines for human exposure to radio frequency energy. This requires the Specific Absorption Rate (SAR) of portable ALS6A-E based applications to be evaluated and approved for compliance with national and/or international regulations.

Since the SAR value varies significantly with the individual product design manufacturers are advised to submit their product for approval if designed for portable use. For US and European markets the relevant directives are mentioned below. It is the responsibility of the manufacturer of the final product to verify whether or not further standards, recommendations or directives are in force outside these areas.

Products intended for sale on US markets

ES 59005/ANSI C95.1 Considerations for evaluation of human exposure to electromagnetic fields (EMFs) from mobile telecommunication equipment (MTE) in the frequency range 30MHz - 6GHz

Products intended for sale on European markets

EN 50360 Product standard to demonstrate the compliance of mobile phones with the basic restrictions related to human exposure to electromagnetic fields (300MHz - 3GHz)

IMPORTANT:





Manufacturers of portable applications based on ALS6A-E modules are required to have their final product certified and apply for their own FCC Grant related to the specific portable mobile.

1.4.3. SELV Requirements

The power supply connected to the ALS6A-E module shall be in compliance with the SELV requirements defined in EN 60950-1.

1.4.4. Safety Precautions

The following safety precautions must be observed during all phases of the operation, usage, service or repair of any cellular terminal or mobile incorporating ALS6A-E. Manufacturers of the cellular terminal are advised to convey the following safety information to users and operating personnel and to incorporate these guidelines into all manuals supplied with the product. Failure to comply with these precautions violates safety standards of design, manufacture and intended use of the product. Kontron assumes no liability for customer's failure to comply with these precautions.

	<p>When in a hospital or other health care facility, observe the restrictions on the use of mobiles. Switch the cellular terminal or mobile off, if instructed to do so by the guidelines posted in sensitive areas. Medical equipment may be sensitive to RF energy.</p> <p>The operation of cardiac pacemakers, other implanted medical equipment and hearing aids can be affected by interference from cellular terminals or mobiles placed close to the device. If in doubt about potential danger, contact the physician or the manufacturer of the device to verify that the equipment is properly shielded. Pacemaker patients are advised to keep their hand-held mobile away from the pacemaker, while it is on.</p>
	<p>Switch off the cellular terminal or mobile before boarding an aircraft. Make sure it cannot be switched on inadvertently. The operation of wireless appliances in an aircraft is forbidden to prevent interference with communications systems. Failure to observe these instructions may lead to the suspension or denial of cellular services to the offender, legal action, or both.</p>
	<p>Do not operate the cellular terminal or mobile in the presence of flammable gases or fumes. Switch off the cellular terminal when you are near petrol stations, fuel depots, chemical plants or where blasting operations are in progress. Operation of any electrical equipment in potentially explosive atmospheres can constitute a safety hazard.</p>
	<p>Your cellular terminal or mobile receives and transmits radio frequency energy while switched on. Remember that interference can occur if it is used close to TV sets, radios, computers or inadequately shielded equipment. Follow any special regulations and always switch off the cellular terminal or mobile wherever forbidden, or when you suspect that it may cause interference or danger.</p>
	<p>IMPORTANT! Cellular terminals or mobiles operate using radio signals and cellular networks. Because of this, connection cannot be guaranteed at all times under all conditions. Therefore, you should never rely solely upon any wireless device for essential communications, for example emergency calls.</p> <p>Remember, in order to make or receive calls, the cellular terminal or mobile must be switched on and in a service area with adequate cellular signal strength.</p> <p>Some networks do not allow for emergency calls if certain network services or phone features are in use (e.g. lock functions, fixed dialing etc.). You may need to deactivate those features before you can make an emergency call.</p> <p>Some networks require that a valid SIM card be properly inserted in the cellular terminal or mobile.</p>

2/ Product Concept

2.1. Key Features at a Glance

Feature	Implementation
<i>General</i>	
Frequency bands	GSM/GPRS/EDGE: Dual band, 900/1800MHz UMTS/HSPA+: Triple band, 900 (BdVIII) / 1800 (BdIII) / 2100MHz (BdI) LTE: Five band, 800 (Bd20) / 900 (Bd8) / 1800 (Bd3) / 2100 (Bd1) / 2600MHz (Bd7)
GSM class	Small MS
Output power (according to Release 99)	Class 4 (+33dBm ±2dB) for EGSM900 Class 1 (+30dBm ±2dB) for GSM1800 Class E2 (+27dBm ± 3dB) for GSM 900 8-PSK Class E2 (+26dBm +3 /-4dB) for GSM 1800 8-PSK Class 3 (+24dBm +1/-3dB) for UMTS 2100, WCDMA FDD BdI Class 3 (+24dBm +1/-3dB) for UMTS 1800, WCDMA FDD BdIII Class 3 (+24dBm +1/-3dB) for UMTS 900, WCDMA FDD BdVIII
Output power (according to Release 8)	Class 3 (+23dBm +-2dB) for LTE 2600, LTE FDD Bd7 Class 3 (+23dBm +-2dB) for LTE 2100, LTE FDD Bd1 Class 3 (+23dBm +-2dB) for LTE 1800, LTE FDD Bd3 Class 3 (+23dBm +-2dB) for LTE 900, LTE FDD Bd8 Class 3 (+23dBm +-2dB) for LTE 800, LTE FDD Bd20
Power supply	$3.3V \leq V_{BATT+} \leq 4.2V$
Operating temperature (board temperature)	Normal operation: -30°C to +85°C Restricted operation: -40°C to +95°C
Physical	Dimensions: 33mm x 29mm x 2.2mm Weight: approx. 4.5g
RoHS	All hardware components fully compliant with EU RoHS Directive
<i>LTE features</i>	
3GPP Release 9	UE CAT 3 supported DL 100Mbps, UL 50Mbps 2x2 MIMO in DL direction
<i>HSPA features</i>	
3GPP Release 8	UE CAT. 14, 24 DC-HSPA+ – DL 42Mbps HSUPA – UL 5.76Mbps Compressed mode (CM) supported according to 3GPP TS25.212
<i>UMTS features</i>	
3GPP Release 8	PS data rate – 384 kbps DL / 384 kbps UL

Feature	Implementation
<i>GSM / GPRS / EGPRS features</i>	
Data transfer	GPRS: <ul style="list-style-type: none"> › Multislot Class 12 › Mobile Station Class B › Coding Scheme 1 – 4 EGPRS: <ul style="list-style-type: none"> › Multislot Class 12 › EDGE E2 power class for 8 PSK › Downlink coding schemes – CS 1-4, MCS 1-9 › Uplink coding schemes – CS 1-4, MCS 1-9 › SRB loopback and test mode B › 8-bit, 11-bit RACH › 1 phase/2 phase access procedures › Link adaptation and IR › NACC, extended UL TBF › Mobile Station Class B
SMS	Point-to-point MT and MO Cell broadcast Text and PDU mode
<i>Software</i>	
AT commands	Hayes, 3GPP TS 27.007 and 27.005, and proprietary Kontron commands
Firmware update	Generic update from host application over USB
<i>Interfaces</i>	
Module interface	Surface mount device with solderable connection pads (SMT application interface). Land grid array (LGA) technology ensures high solder joint reliability and provides the possibility to use an optional module mounting socket. For more information on how to integrate SMT modules see also [3]. This application note comprises chapters on module mounting and application layout issues as well as on additional SMT application development equipment.
Antenna	50Ω. GSM/UMTS/LTE main antenna, UMTS/LTE Diversity/MIMO antenna
USB	USB 2.0 High Speed (480Mbit/s) device interface
UICC interface	Supported chip cards: UICC/SIM/USIM 3V, 1.8V
Audio	1 digital interface (PCM)
RINGO	Signal line to indicate incoming calls and other types of URCs
<i>Power on/off, Reset</i>	
Power on/off	Switch-on by hardware signal IGT Switch-off by AT command (AT^SMSO) or IGT Automatic switch-off in case of critical temperature or voltage conditions
Reset	Orderly shutdown and reset by AT command
Emergency-off	Emergency-off by hardware signal EMERG_OFF if IGT is not active
<i>Special Features</i>	
Antenna	SAIC (Single Antenna Interference Cancellation) / DARP (Downlink Advanced Receiver Performance) Rx Diversity (receiver type 3i - 64-QAM) / MIMO

Feature	Implementation
GPIO	10 I/O pins of the application interface programmable as GPIO. Programming is done via AT commands. GPIOs can be configured for antenna diagnosis.
ADC inputs	Analog-to-Digital Converter with two unbalanced analog inputs for (external) antenna diagnosis.
<i>Evaluation kit</i>	
Evaluation module	ALS6A-E module soldered onto a dedicated PCB that can be connected to an adapter in order to be mounted onto the DSB75.
DSB75	DSB75 Development Support Board designed to test and type approve Kontron modules and provide a sample configuration for application engineering. A special adapter is required to connect the ALS6A-E evaluation module to the DSB75.

2.2. ALS6A-E System Overview

Figure 1: ALS6A-E system overview

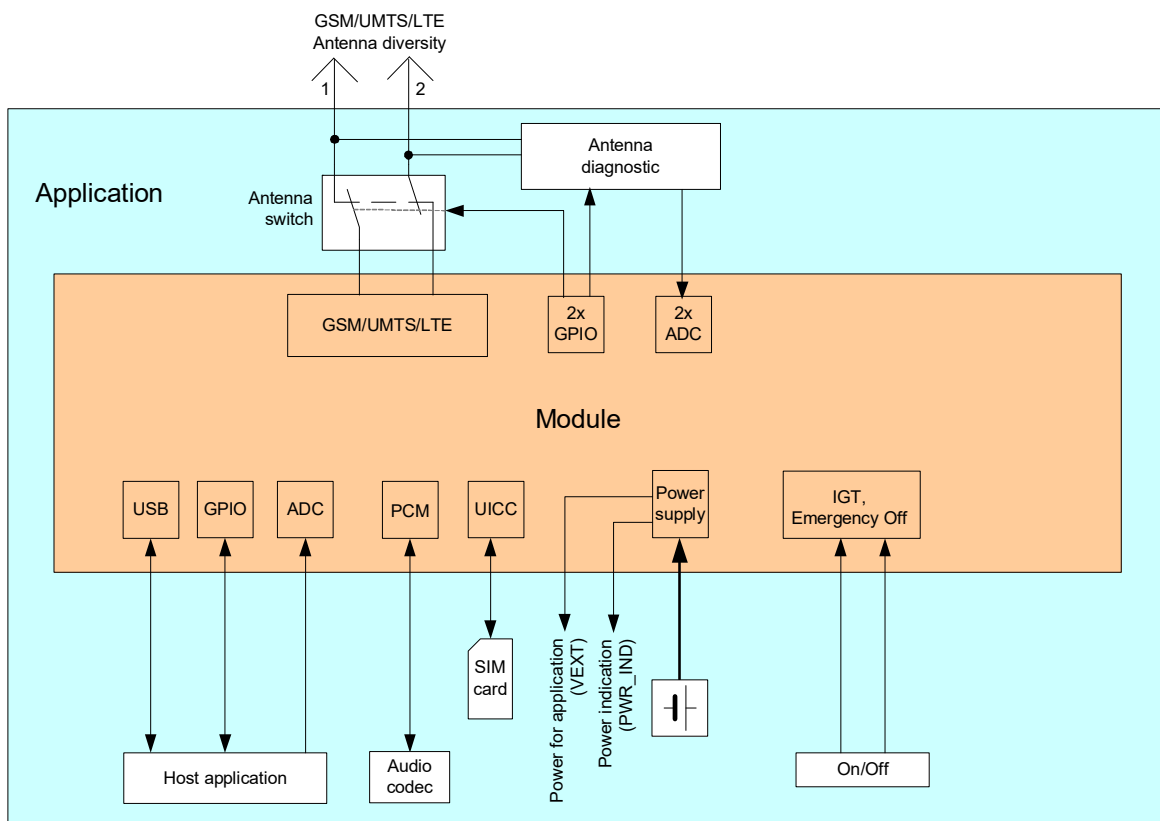

2.3. Circuit Concept

Figure 2 shows a block diagram of the ALS6A-E module and illustrates the major functional components:

Baseband block:

- › GSM/UMTS controller/transceiver/power supply
- › Stacked Flash/RAM memory with multiplexed address data bus
- › Application interface (SMT with connecting pads)

RF section:

- › RF transceiver
- › RF power amplifier/frontend
- › RF filter
- › Antenna pad

Figure 2: ALS6A-E block diagram

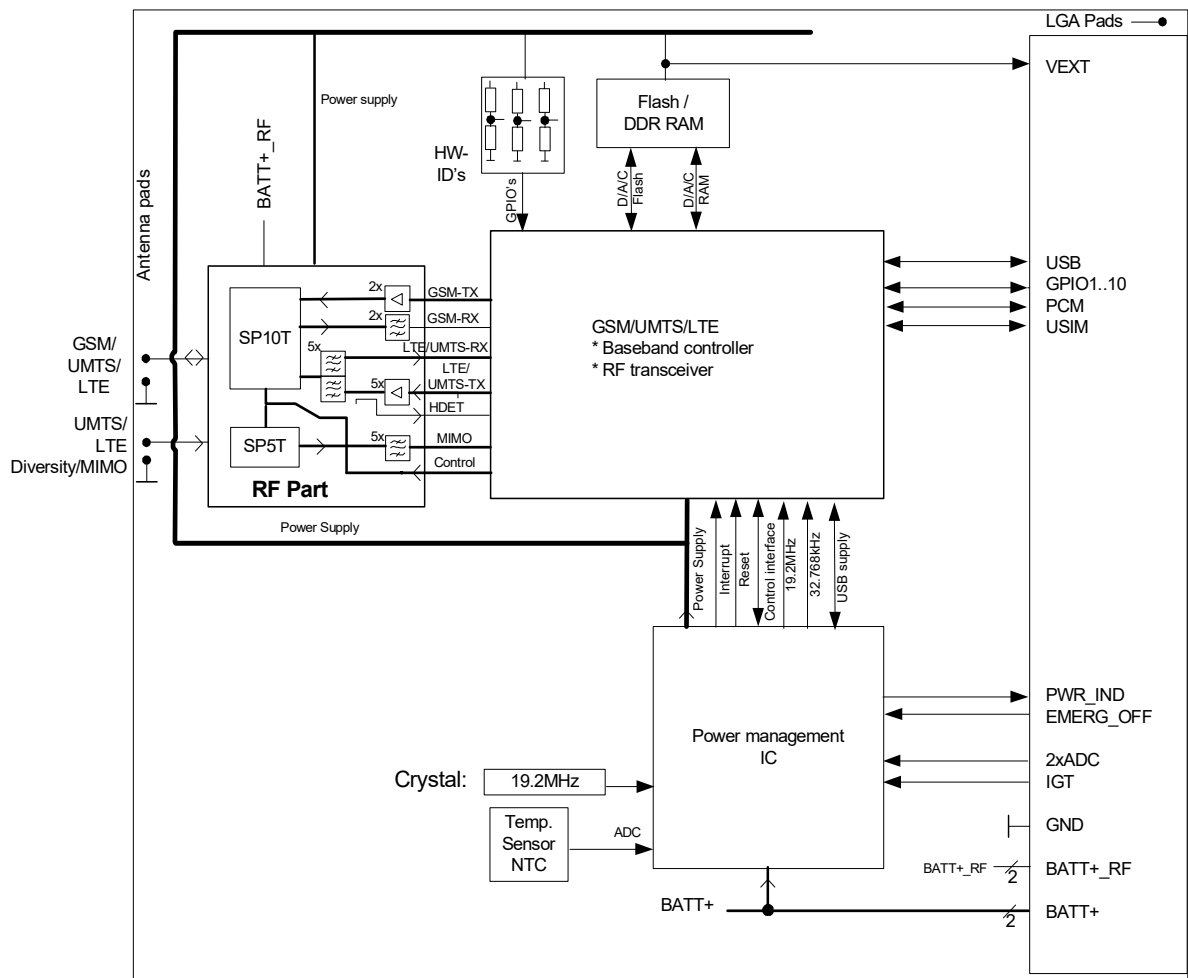

3/ Application Interface

ALS6A-E is equipped with an SMT application interface (LGA pads) that connects to the external application. The host interface incorporates several sub-interfaces described in the following sections:

- › Operating modes - see [Section 3.1](#).
- › Power supply - see [Section 3.2](#).
- › Serial interface USB - see [Section 3.5](#).
- › UICC/SIM/USIM interface - see [Section 3.6](#).
- › Digital audio interface - see [Section 3.7](#).
- › ADC interface - [Section 3.8](#).
- › GPIO interface - [Section 3.9](#).
- › Control lines: PWR_IND, RING0 - see [Section 3.10](#).

3.1. Operating Modes

The table below briefly summarizes the various operating modes referred to in the following chapters.

Table 7: Overview of operating modes

Mode	Function	
Normal operation	GSM / GPRS / UMTS / HSPA / LTE SLEEP	Power saving set automatically when no call is in progress and the USB connection is detached.
	GSM / GPRS / UMTS / HSPA / LTE IDLE	Power saving disabled or an USB connection active, but no data transfer in progress.
	GPRS DATA	GPRS data transfer in progress. Power consumption depends on network settings (e.g. power control level), uplink / downlink data rates and GPRS configuration (e.g. used multislot settings).
	EGPRS DATA	EGPRS data transfer in progress. Power consumption depends on network settings (e.g. power control level), uplink / downlink data rates and EGPRS configuration (e.g. used multislot settings).
	UMTS DATA	UMTS data transfer in progress. Power consumption depends on network settings (e.g. TPC Pattern) and data transfer rate.
	HSPA DATA	HSPA data transfer in progress. Power consumption depends on network settings (e.g. TPC Pattern) and data transfer rate.
	LTE DATA	LTE data transfer in progress. Power consumption depends on network settings (e.g. TPC Pattern) and data transfer rate.
Power Down	Normal shutdown after sending the AT^SMSO command. Software is not active. Interfaces are not accessible. Operating voltage (connected to BATT+) remains applied.	
Airplane mode	Airplane mode shuts down the radio part of the module, causes the module to log off from the GSM/GPRS network and disables all AT commands whose execution requires a radio connection. Airplane mode can be controlled by AT command (see [1]).	

3.2. Power Supply

ALS6A-E needs to be connected to a power supply at the SMT application interface - 4 lines BATT+, and GND. There are two separate voltage domains for BATT+:

- › BATT+_RF with 2 lines for the RF power amplifier supply
- › BATT+ with 2 lines for the general power management.

The main power supply from an external application has to be a single voltage source and has to be expanded to two sub paths (star structure). Each voltage domain must be decoupled by application with low ESR capacitors ($\geq 47\mu\text{F}$ MLCC @ BATT+; $\geq 4 \times 47\mu\text{F}$ MLCC @ BATT+_RF) as close as possible to LGA pads. [Figure 3](#) shows a sample circuit for decoupling capacitors for BATT+.

Figure 3: Decoupling capacitor(s) for BATT+

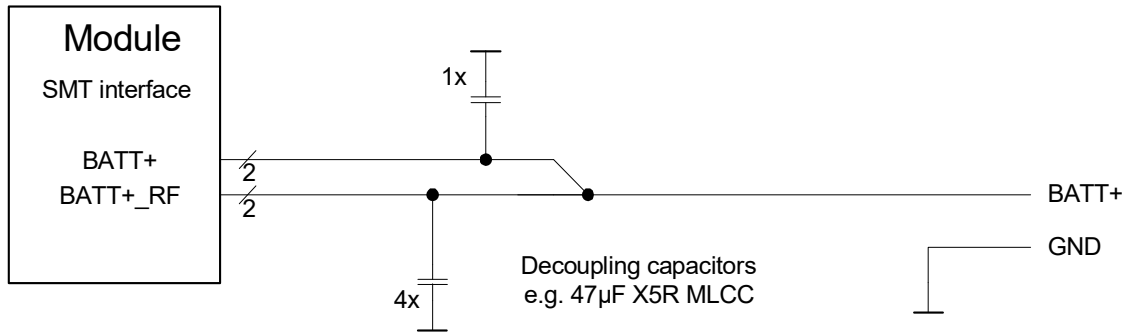

The power supply of ALS6A-E must be able to provide the peak current during the uplink transmission.

All key functions for supplying power to the device are handled by the power management IC. It provides the following features:

- › Stabilizes the supply voltages for the baseband using switching regulators and low drop linear voltage regulators.
- › Switches the module's power voltages for the power-up and -down procedures.
- › Delivers, across the VEXT line, a regulated voltage for an external application.
- › LDO to provide SIM power supply.

3.2.1. Minimizing Power Losses

When designing the power supply for your application please pay specific attention to power losses. Ensure that the input voltage $V_{\text{BATT+}}$ never drops below 3.3V on the ALS6A-E board, not even in a transmit burst where current consumption can rise to typical peaks of 2A. It should be noted that ALS6A-E switches off when exceeding these limits. Any voltage drops that may occur in a transmit burst should not exceed 400mV to ensure the expected RF performance in 2G networks.

The module switches off if the minimum battery voltage (V_{BATTmin}) is reached.

Example:

$V_{\text{Imin}} = 3.3\text{V}$

$D_{\text{max}} = 0.4\text{V}$

$V_{\text{BATTmin}} = V_{\text{Imin}} + D_{\text{max}}$

$V_{\text{BATTmin}} = 3.3\text{V} + 0.4\text{V} = 3.7\text{V}$

Figure 4: Power supply limits during transmit burst

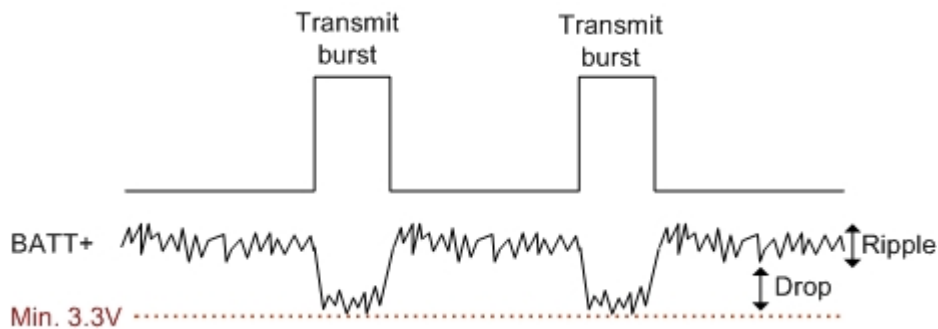

3.2.2. Monitoring Power Supply by AT Command

To monitor the supply voltage you can use the AT[^]SBV command which returns the averaged value related to BATT+ and GND at the SMT application interface.

The module continuously measures the voltage at intervals depending on the operating mode of the RF interface. The duration of measuring ranges from 0.5 seconds in DATA mode to 50 seconds when ALS6A-E is in Limited Service (deregistered). The displayed voltage (in mV) is averaged over the last measuring period before the AT[^]SBV command was executed.

3.3. Power-Up / Power-Down Scenarios

In general, be sure not to turn on ALS6A-E while it is beyond the safety limits of voltage and temperature stated in [Section 5.1.](#) ALS6A-E immediately switches off after having started and detected these inappropriate conditions. In extreme cases this can cause permanent damage to the module.

3.3.1. Turn on ALS6A-E

When the ALS6A-E module is in Power Down mode, it can be started to Normal mode by driving the IGT (ignition) line to ground. It is recommended to use an open drain/collector driver to avoid current flowing into this signal line. Pulling this signal low triggers a power-on sequence. To turn on ALS6A-E, IGT has to be kept active at least 100 milliseconds. After turning on ALS6A-E, IGT should be set inactive to prevent the module from turning on again after a shut down by AT command or EMERG_OFF. For details on signal states during startup see also [Section 3.3.2.](#)

Figure 5: Power-on with IGT

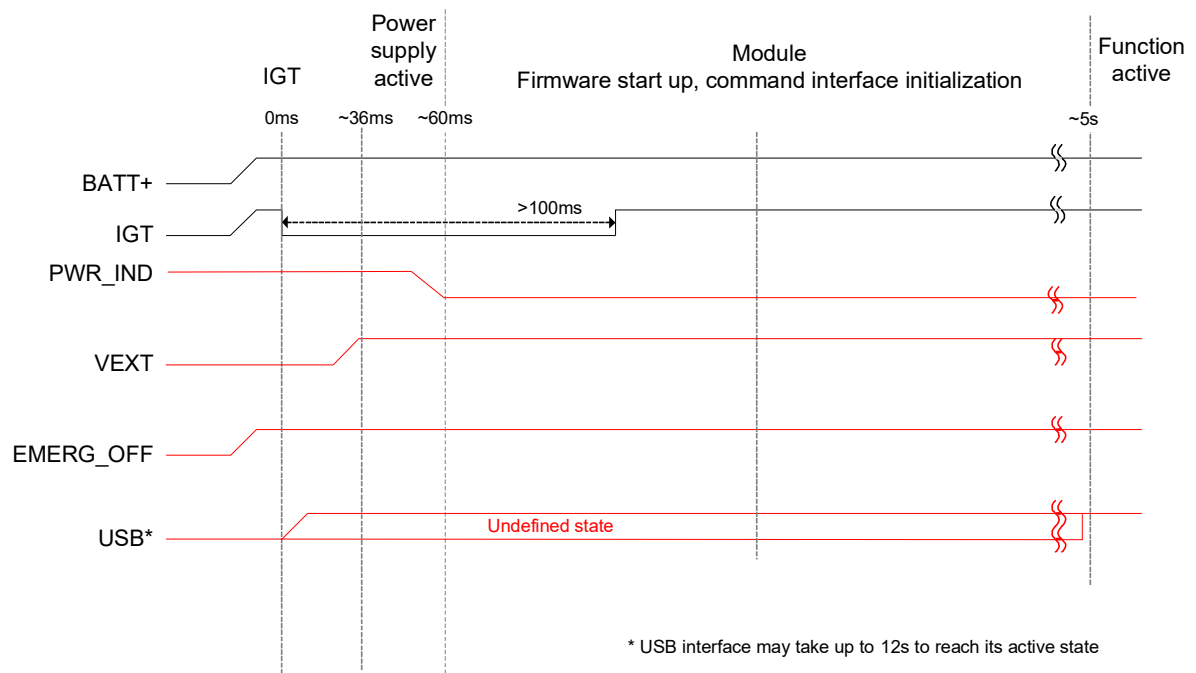

Note: After power up IGT should remain high. Also note that with a USB connection the USB host may take up to 12 seconds to set up the virtual COM port connection.

After startup or mode change the following URCs are indicating the module's ready state:

- ▶ "`^SYSSTART`" indicates that the module has entered Normal mode.
- ▶ "`^SYSSTART AIRPLANE MODE`" indicates that the module has entered Airplane mode.

These URCs notify the external application that the first AT command can be sent to the module. If these URCs are not used to detect then the only way of checking the module's ready state is polling. To do so, try to send characters (e.g. "at") until the module is responding.

3.3.2. Signal States after Startup

Table 8 describes the various states each interface signal passes through after startup and during operation.

Signals are in an initial state while the module is initializing. Once the startup initialization has completed, i.e. when the software is running, all signals are in defined state. The state of several signals will change again once the respective interface is activated or configured by AT command.

Table 8: Signal states

Signal name	Power on reset Duration appr. 60ms	Startup phase Duration appr. 4s	State after first firmware initialization After 4-5s
CCIN	PD and PU (24k)	PU(24k)	I, PU(24k)
CCRST	Not driven (similar PD)	Not driven (similar PD)	O, L ¹ O, H ²
CCIO	PD(10k)	PD(10k)	PD(10k) ¹ PU(10k) ²
CCCLK	Not driven (similar PD)	Not driven (similar PD)	O, L ¹ Clock ²
CCVCC	Off	Off	Off ¹ 1.8V/3V ²
RING0	PD	O, H	O, H
PCM_IN	PU	PD	PD
PCM_CLK	PD	PD	PD
PCM_FSC	PD	PD	PD
PCM_OUT	PD	PD	PD
PWR_IND	Z	O, L	O, L
EMERG_OFF	PU	I, PU	I, PU
IGT	I, PU	I, PU	I, PU
GPIO1...10 ³	PD	PD	PD

¹ If CCIN = High level

² If CCIN = Low level

³ Please note that during its startup phase the GPIO8 signal will be in an active low state for appr. 80ms.

L = Low level H = High level I = Input O = Output	PD = Pull down resistor with appr. 100k ¹ PD(...k) = Pull down resistor with ...k PU = Pull up resistor with appr. 100k PU(...k) = Pull up resistor with ...k, Z = High impedance
--	--

¹ Internal pulls are implemented using JFETs; strengths vary between devices, possible range: 55k...390k

3.3.3. Turn off ALS6A-E Using AT Command

The best and safest approach to powering down ALS6A-E is to issue the AT^SMSO command. This procedure lets ALS6A-E log off from the network and allows the software to enter into a secure state and save data before disconnecting the power supply. The mode is referred to as Power Down mode. After sending AT^SMSO do not enter any other AT commands. While powering down the module may still send some URCs. To verify that the module turned off it is possible to monitor the PWR_IND signal. A high state of the PWR_IND signal indicates that the module is being switched off as shown in Figure 6.

Be sure not to disconnect the supply voltage V_{BATT+} before the module's switch off procedure has been completed and the VEXT signal has gone low. Otherwise you run the risk of losing data. Signal states during switch off are shown in Figure 6.

While ALS6A-E is in Power Down mode the application interface is switched off and must not be fed from any other source. Therefore, your application must be designed to avoid any current flow into any digital signal lines of the application interface. No special care is required for the USB interface which is protected from reverse current.

Figure 6: Signal states during turn-off procedure

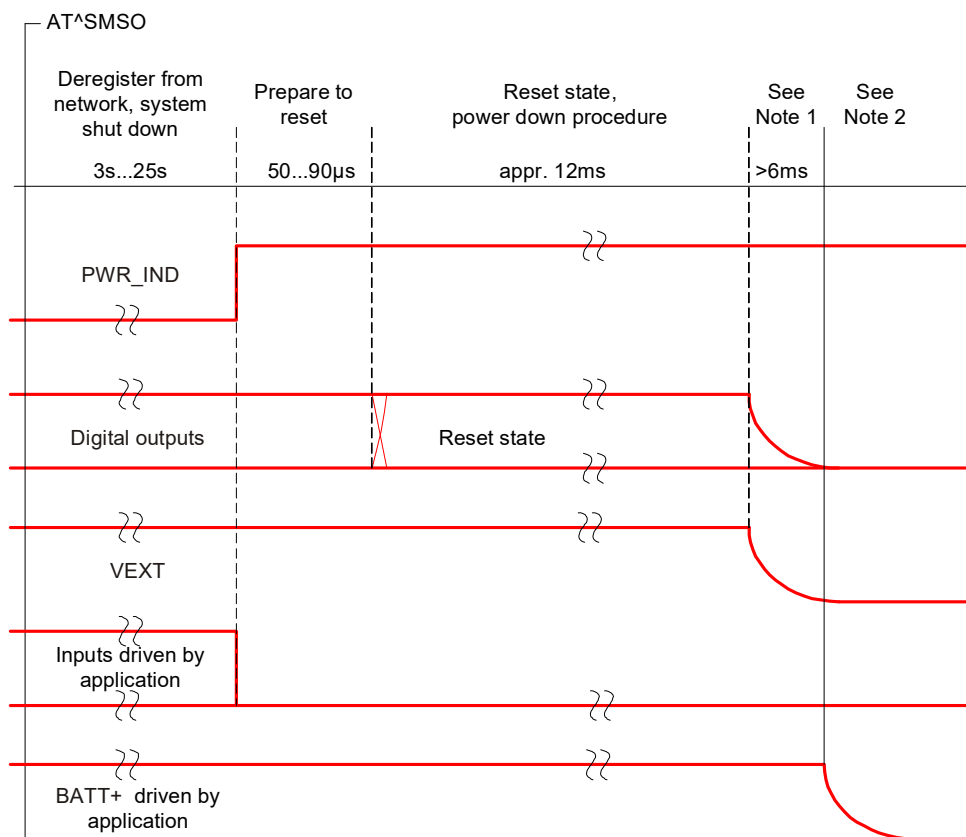

- Note 1: Depending on capacitance load from host application
- Note 2: The power supply voltage (BATT+) may be disconnected or switched off only after the VEXT went low.
- Note 3: After module shutdown by means of AT command is completed, please allow for a time period of at least 1 second before restarting the module.

3.3.4. Turn off ALS6A-E Using IGT Line

The IGT line can be used to switch off ALS6A-E. If the module is on, the IGT line must be asserted for at least 2.1 seconds before being released. The module switches off after the line is released. The switch-off routine is identical with the procedure initiated by AT^SMSO, i.e. the software performs an orderly shutdown as described in Section 3.3.3.. Before switching off the module wait at least 12 seconds after startup.

Figure 7: Timing of IGT if used to switch off the module

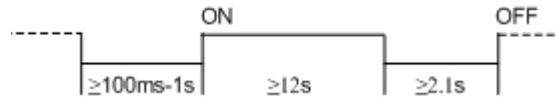

3.3.5. Automatic Shutdown

Automatic shutdown takes effect if:

- ▶ The ALS6A-E board is exceeding the critical limits of overtemperature or undertemperature
- ▶ Undervoltage or overvoltage is detected

The automatic shutdown procedure is equivalent to the power down initiated with the AT^SMSO command, i.e. ALS6A-E logs off from the network and the software enters a secure state avoiding loss of data.

Alert messages transmitted before the device switches off are implemented as Unsolicited Result Codes (URCs). The presentation of the temperature URCs can be enabled or disabled with the AT commands AT^SCTM. The URC presentation mode varies with the condition, please see Section 3.3.5.1. to Section 3.3.5.4. for details. For further instructions on AT commands refer to [1].

3.3.5.1. Thermal Shutdown

The board temperature is constantly monitored by an internal NTC resistor located on the PCB. The values detected by the NTC resistor are measured directly on the board and therefore, are not fully identical with the ambient temperature.

Each time the board temperature goes out of range or back to normal, ALS6A-E instantly displays an alert (if enabled).

- ▶ URCs indicating the level "1" or "-1" allow the user to take appropriate precautions, such as protecting the module from exposure to extreme conditions. The presentation of the URCs depends on the settings selected with the AT^SCTM write command:
 - AT^SCTM=1: Presentation of URCs is always enabled.
 - AT^SCTM=0 (default): Presentation of URCs is enabled during the 2 minutes guard period after start-up of ALS6A-E. After expiry of the 2 minutes guard period, the presentation will be disabled, i.e. no URCs with alert levels "1" or "-1" will be generated.
- ▶ URCs indicating the level "2" or "-2" are instantly followed by an orderly shutdown. The presentation of these URCs is always enabled, i.e. they will be output even though the factory setting AT^SCTM=0 was never changed.

The maximum temperature ratings are stated in Section 5.2.. Refer to Table 9 for the associated URCs.

Table 9: Temperature dependent behavior

Sending temperature alert (2 minutes after ALS6A-E start-up, otherwise only if URC presentation enabled)	
^SCTM_B: 1	Caution: Board close to overtemperature limit, i.e., board is 5°C below overtemperature limit.
^SCTM_B: -1	Caution: Board close to undertemperature limit, i.e., board is 5°C above undertemperature limit.
^SCTM_B: 0	Board back to uncritical temperature range, i.e., board is 6°C below its over- or above its undertemperature limit.
Automatic shutdown (URC appears no matter whether or not presentation was enabled)	
^SCTM_B: 2	Alert: Board equal or beyond overtemperature limit. ALS6A-E switches off.
^SCTM_B: -2	Alert: Board equal or below undertemperature limit. ALS6A-E switches off.

The AT^SCTM command can also be used to check the present status of the board. Depending on the selected mode, the read command returns the current board temperature in degrees Celsius or only a value that indicates whether the board is within the safe or critical temperature range. See [1] for further instructions.

3.3.5.2. Deferred Shutdown at Extreme Temperature Conditions

In the following cases, automatic shutdown will be deferred if a critical temperature limit is exceeded:

- › While an emergency call is in progress.
- › During a two minute guard period after power-up. This guard period has been introduced in order to allow for the user to make an emergency call. The start of any one of these calls extends the guard period until the end of the call. Any other network activity may be terminated by shutdown upon expiry of the guard time.

While in a "deferred shutdown" situation, ALS6A-E continues to measure the temperature and to deliver alert messages, but deactivates the shutdown functionality. Once the 2 minute guard period is expired or the call is terminated, full temperature control will be resumed. If the temperature is still out of range, ALS6A-E switches off immediately (without another alert message).

CAUTION! Automatic shutdown is a safety feature intended to prevent damage to the module. Extended usage of the deferred shutdown facilities provided may result in damage to the module, and possibly other severe consequences.

3.3.5.3. Undervoltage Shutdown

If the measured battery voltage is no more sufficient to set up a call the following URC will be presented:

^SBC: Undervoltage.

The URC indicates that the module is close to the undervoltage threshold. If undervoltage persists the module keeps sending the URC several times before switching off automatically.

This type of URC does not need to be activated by the user. It will be output automatically when fault conditions occur.

3.3.5.4. Overvoltage Shutdown

The overvoltage shutdown threshold is 100mV above the maximum supply voltage $V_{\text{BATT+}}$ specified in [Table 21](#).

When the supply voltage approaches the overvoltage shutdown threshold the module will send the following URC:

^SBC: Overvoltage warning

This alert is sent once.

When the overvoltage shutdown threshold is exceeded the module will send the following URC

^SBC: Overvoltage shutdown

before it shuts down cleanly.

This type of URC does not need to be activated by the user. It will be output automatically when fault conditions occur.

Keep in mind that several ALS6A-E components are directly linked to BATT+ and, therefore, the supply voltage remains applied at major parts of ALS6A-E, even if the module is switched off. Especially the power amplifier is very sensitive to high voltage and might even be destroyed.

3.3.6. Turn off ALS6A-E in Case of Emergency

Caution: Use the EMERG_OFF line only when, due to serious problems, the software is not responding for more than 5 seconds. Pulling the EMERG_OFF line causes the loss of all information stored in the volatile memory. Therefore, this procedure is intended only for use in case of emergency, e.g. if ALS6A-E does not respond, if reset or shutdown via AT command fails.

The EMERG_OFF line is available on the application interface and can be used to switch off the module. To control the EMERG_OFF line it is recommended to use an open drain / collector driver.

To switch off, the EMERG_OFF line must be pulled to ground for longer than 40 milliseconds. After the 40 milliseconds and an additional delay period of 500 milliseconds the module shuts down as shown in Figure 8.

Figure 8: Shutdown by EMERG_OFF signal

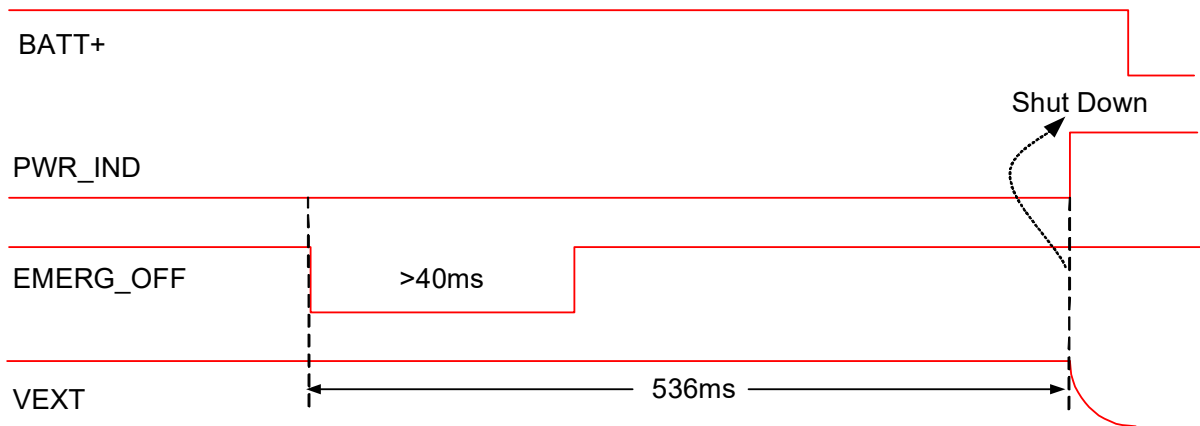

Note: The power supply voltage (BATT+) may be disconnected or switched off only after having reached Shut Down as indicated by the PWR_IND signal going high. The power supply has to be available (again) before the module is restarted.

3.4. Power Saving

ALS6A-E is able to reduce its functionality to a minimum (during the so-called SLEEP mode) in order to minimize its current consumption. The following sections explain the module's network dependant power saving behavior. The implementation of the USB host interface also influences the module's power saving behavior and therefore its current consumption. For more information see [Section 3.5.](#)

3.4.1. Power Saving while Attached to GSM Networks

The power saving possibilities while attached to a GSM network depend on the paging timing cycle of the base station. The duration of a power saving interval can be calculated using the following formula:

$$t = 4.615 \text{ ms (TDMA frame duration)} * 51 \text{ (number of frames)} * \text{DRX value.}$$

DRX (Discontinuous Reception) is a value from 2 to 9, resulting in paging intervals between 0.47 and 2.12 seconds. The DRX value of the base station is assigned by the GSM network operator.

In the pauses between listening to paging messages, the module resumes power saving, as shown in [Figure 9.](#)

Figure 9: Power saving and paging in GSM networks

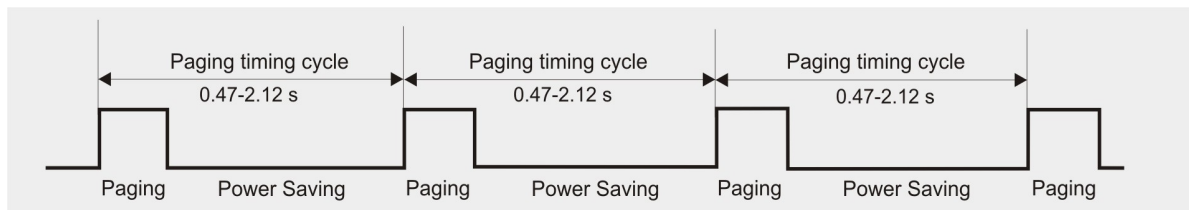

The varying pauses explain the different potential for power saving. The longer the pause the less power is consumed.

Generally, power saving depends on the module's application scenario and may differ from the above mentioned normal operation. The power saving interval may be shorter than 0.47 seconds or longer than 2.12 seconds.

3.4.2. Power Saving while Attached to WCDMA Networks

The power saving possibilities while attached to a WCDMA network depend on the paging timing cycle of the base station.

During normal WCDMA operation, i.e., the module is connected to a WCDMA network, the duration of a power saving period varies. It may be calculated using the following formula:

$$t = 2^{\text{DRX value}} * 10 \text{ ms (WCDMA frame duration).}$$

DRX (Discontinuous Reception) in WCDMA networks is a value between 6 and 9, thus resulting in power saving intervals between 0.64 and 5.12 seconds. The DRX value of the base station is assigned by the WCDMA network operator.

In the pauses between listening to paging messages, the module resumes power saving, as shown in [Figure 10.](#)

Figure 10: Power saving and paging in WCDMA networks

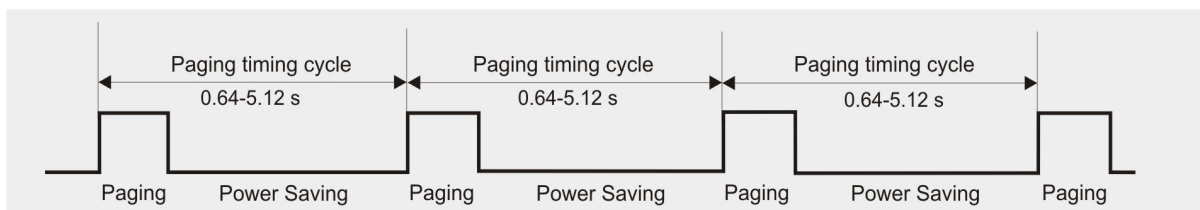

The varying pauses explain the different potential for power saving. The longer the pause the less power is consumed.

Generally, power saving depends on the module's application scenario and may differ from the above mentioned normal operation. The power saving interval may be shorter than 0.64 seconds or longer than 5.12 seconds.

3.4.3. Power Saving while Attached to LTE Networks

The power saving possibilities while attached to an LTE network depend on the paging timing cycle of the base station.

During normal LTE operation, i.e., the module is connected to an LTE network, the duration of a power saving period varies. It may be calculated using the following formula:

$$t = \text{DRX Cycle Value} * 10 \text{ ms}$$

DRX cycle value in LTE networks is any of the four values: 32, 64, 128 and 256, thus resulting in power saving intervals between 0.32 and 2.56 seconds. The DRX cycle value of the base station is assigned by the LTE network operator.

In the pauses between listening to paging messages, the module resumes power saving, as shown in [Figure 11](#).

Figure 11: Power saving and paging in LTE networks

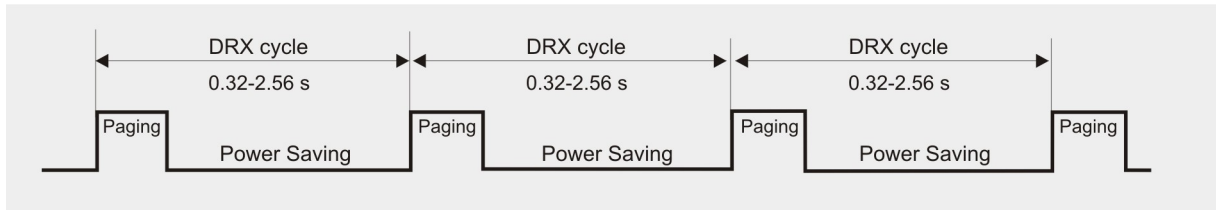

The varying pauses explain the different potential for power saving. The longer the pause the less power is consumed.

Generally, power saving depends on the module's application scenario and may differ from the above mentioned normal operation. The power saving interval may be shorter than 0.32 seconds or longer than 2.56 seconds.

3.5. USB Interface

ALS6A-E supports a USB 2.0 High Speed (480Mbps) device interface. The USB interface is primarily intended for use as command and data interface and for downloading firmware.

The USB host is responsible for supplying the VUSB_IN line. This line is for voltage detection only. The USB part (driver and transceiver) is supplied by means of BATT+. This is because ALS6A-E is designed as a self-powered device compliant with the “Universal Serial Bus Specification Revision 2.0”¹.

Figure 12: USB circuit

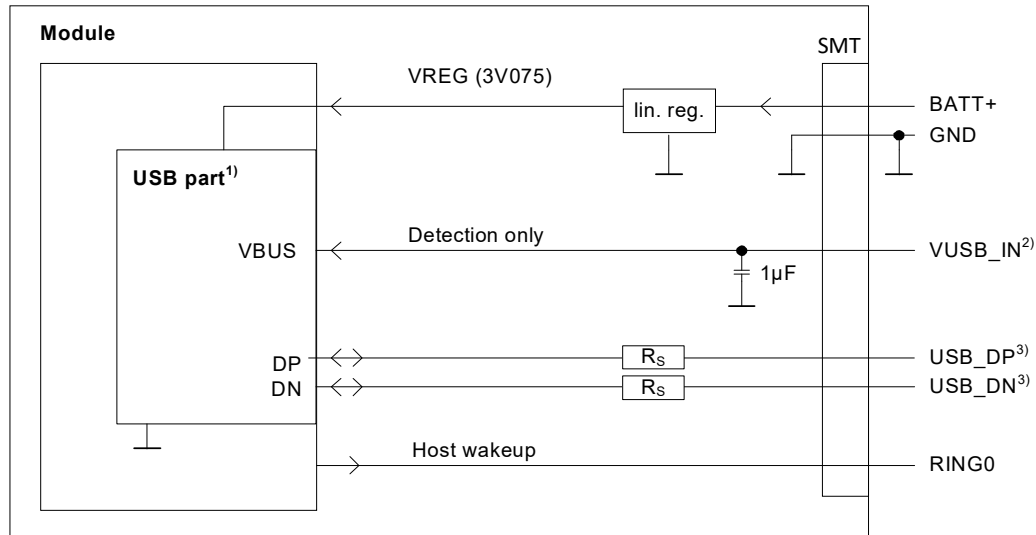

¹) All serial (including R_s) and pull-up resistors for data lines are implemented.

²) Since VUSB_IN is used for detection only it is recommended not to add any further blocking capacitors on the VUSB_IN line.

³) If the USB interface is operated in High Speed mode (480MHz), it is recommended to take special care routing the data lines USB_DP and USB_DN. Application layout should in this case implement a differential impedance of 90 ohms for proper signal integrity.

To properly connect the module's USB interface to the external application, a USB 2.0 compatible connector and cable or hardware design is required. For more information on the USB related signals see [Table 21](#). Furthermore, the USB modem driver distributed with ALS6A-E needs to be installed.

While a USB connection is active, the module will never switch into SLEEP mode. Only if the USB interface is in Detached state (i.e., VUSB_IN = 0) the module is able to switch into SLEEP mode thereby saving power. In this case the RINGO line can be employed to wake up the external application when events signaled by URCs are detected (incl. incoming SMS). Every wakeup event will force a new USB enumeration. Therefore, the external application has to carefully consider the enumeration timings to avoid losing any signalled events. For information on the RINGO line behavior see [Section 3.10.2.](#)

¹ The specification is ready for download on <http://www.usb.org/developers/docs/>

3.6. UICC/SIM/USIM Interface

ALS6A-E has an integrated UICC/SIM/USIM interface compatible with the 3GPP 31.102 and ETSI 102 221. This is wired to the host interface in order to be connected to an external SIM card holder. Five pads on the SMT application interface are reserved for the SIM interface.

The UICC/SIM/USIM interface supports 3V and 1.8V SIM cards. Please refer to [Table 21](#) for electrical specifications of the UICC/SIM/USIM interface lines depending on whether a 3V or 1.8V SIM card is used.

The CCIN signal serves to detect whether a tray (with SIM card) is present in the card holder. Using the CCIN signal is mandatory for compliance with the GSM 11.11 recommendation if the mechanical design of the host application allows the user to remove the SIM card during operation. To take advantage of this feature, an appropriate SIM card detect switch is required on the card holder. For example, this is true for the model supplied by Molex, which has been tested to operate with ALS6A-E and is part of the Kontron reference equipment submitted for type approval. See [Chapter 9](#) for Molex ordering numbers.

Table 10: Signals of the SIM interface (SMT application interface)

Signal	Description
GND	Ground connection for SIM. Optionally a separate SIM ground line using e.g., pad N11 may be used to improve EMC.
CCCLK	Chipcard clock
CCVCC	SIM supply voltage.
CCIO	Serial data line, input and output.
CCRST	Chipcard reset
CCIN	Input on the baseband processor for detecting a SIM card tray in the holder. If the SIM is removed during operation the SIM interface is shut down immediately to prevent destruction of the SIM. The CCIN signal is active low. The CCIN signal is mandatory for applications that allow the user to remove the SIM card during operation. The CCIN signal is solely intended for use with a SIM card. It must not be used for any other purposes. Failure to comply with this requirement may invalidate the type approval of ALS6A-E.

Note: No guarantee can be given, nor any liability accepted, if loss of data is encountered after removing the SIM card during operation. Also, no guarantee can be given for properly initializing any SIM card that the user inserts after having removed the SIM card during operation. In this case, the application must restart ALS6A-E.

Figure 13: UICC/SIM/USIM interface

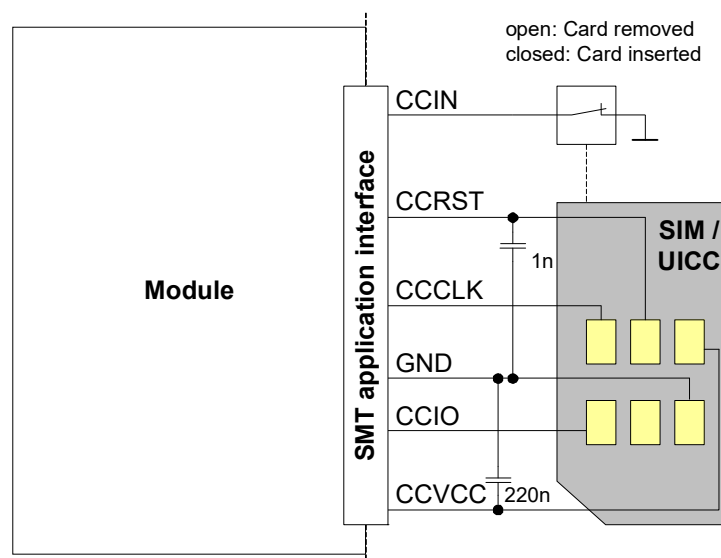

The total cable length between the SMT application interface pads on ALS6A-E and the pads of the external SIM card holder must not exceed 100mm in order to meet the specifications of 3GPP TS 51.010-1 and to satisfy the requirements of EMC compliance.

To avoid possible cross-talk from the CCCLK signal to the CCIO signal be careful that both lines are not placed closely next to each other. A useful approach is using the GND line to shield the CCIO line from the CCCLK line.

An example for an optimized ESD protection for the SIM interface is shown in [Section 3.6.1.](#)

3.6.1. Enhanced ESD Protection for SIM Interface

To optimize ESD protection for the SIM interface it is possible to add ESD diodes to the SIM interface lines as shown in the example given in [Figure 14.](#)

The example was designed to meet ESD protection according ETSI EN 301 489-1/7: Contact discharge: ± 4kV, air discharge: ± 8kV.

Figure 14: SIM interface - enhanced ESD protection

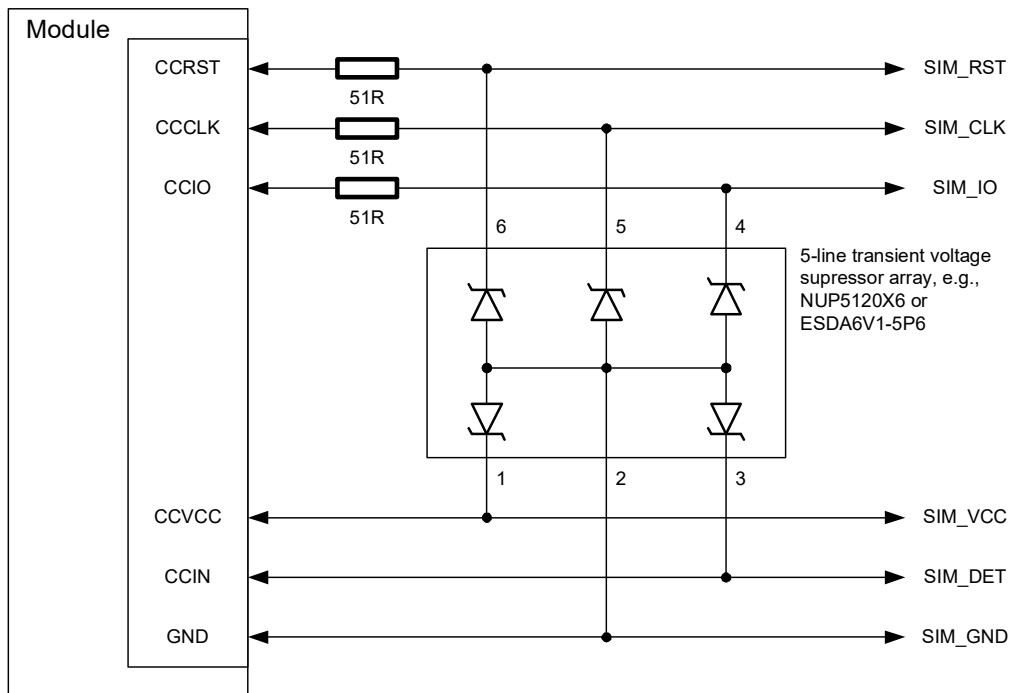

3.7. Digital Audio Interface

ALS6A-E supports a digital audio interface that can be employed as pulse code modulation interface (see [Section 3.7.1.](#)).

3.7.1. Pulse Code Modulation Interface (PCM)

ALS6A-E's PCM interface can be used to connect audio devices capable of pulse code modulation. The PCM functionality is limited to the use of wideband codecs with 16kHz sample rate only. The PCM interface runs at 16 kHz sample rate (62.5µs frame length), while the signal processing maintains this rate in a wideband AMR call or samples automatically down to 8kHz in a narrowband call. Therefore, the PCM sample rate is independent of the audio bandwidth of the call.

The PCM interface has the following implementation:

- Master mode
- Short frame synchronization
- 4096kHz bit clock at 16kHz sample rate

[Table 11](#) lists the available PCM interface signals.

Table 11: Overview of PCM pin functions

Signal name on SMT application interface	Signal direction: Master	Description
PCM_OUT	O	PCM Data from ALS6A-E to external codec
PCM_IN	I	PCM Data from external codec to ALS6A-E
PCM_FSC	O	Frame synchronization signal to external codec
PCM_CLK	O	Bit clock to external codec

Note: PCM data is always formatted as 16-bit uncompressed two's complement. Also, all PCM data and frame synchronization signals are written to the PCM bus on the rising clock edge and read on the falling edge.

The timing of a PCM short frame is shown in [Figure 15](#).

Figure 15: PCM timing short frame (master, 4096KHz)

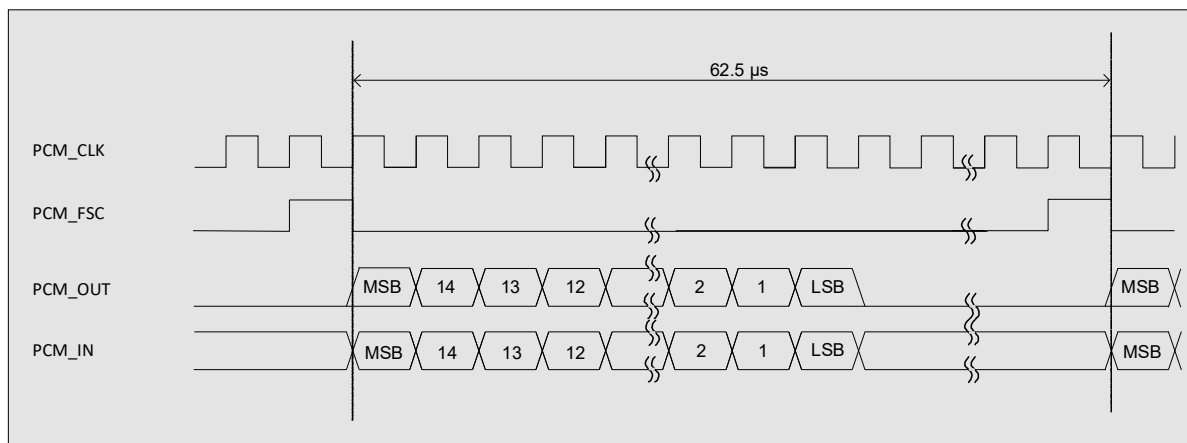

Characteristics of Audio Modes

ALS6A-E has various audio modes selectable with AT^SNFS (for details on AT^SNFS see [\[1\]](#)).

Audio mode 1 is only used for type approval with the Votronic handset via the DSB75 codec adapter. The handset is adjusted for the type 3.2 low-leakage ear simulator for narrowband and wideband calls. The characteristics of this mode cannot be changed.

Audio mode 6 is used for transparent access to the narrowband or wideband speech coders without any signal processing (except for sample rate converters in case of narrowband calls). The full scale level of the PCM interface is mapped to the full scale level of the speech coders.

3.8. Analog-to-Digital Converter (ADC)

ALS6A-E provides two unbalanced ADC input lines: ADC1_IN and ADC2_IN. They can be used to measure two independent, externally connected DC voltages in the range of 0.3V to 3.075V. As described in [Section 4.1.3](#), they can be used especially for antenna diagnosing.

The AT[^]SRADC command can be employed to select the ADC line, set the measurement mode and read out the measurement results.

3.9. GPIO Interface

ALS6A-E has 10 GPIOs for external hardware devices. Each GPIO can be configured for use as input or output. All settings are AT command controlled.

The IO port driver has to be open before using and configuring GPIOs. Before changing the configuration of a GPIO pin (e.g. input to output) the pin has to be closed. If the GPIO pins are not configured or the pins/driver were closed, the GPIO pins are high-Z with pull down resistor. If a GPIO is configured to input, the pin has high-Z without pull resistor.

3.10. Control Signals

3.10.1. PWR_IND Signal

PWR_IND notifies the on/off state of the module. High state of PWR_IND indicates that the module is switched off. The state of PWR_IND immediately changes to low when IGT is pulled low. For state detection an external pull-up resistor is required.

Figure 16: PWR_IND signal

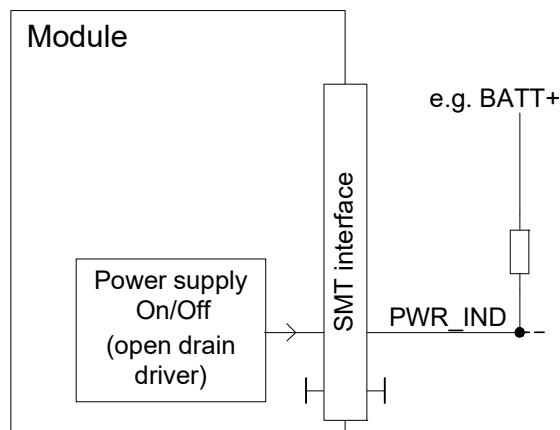

3.10.2. Behavior of the RING0 Line

The RING0 line serves to indicate incoming calls and other types of URCs (Unsolicited Result Code).

Although not mandatory for use in a host application, it is strongly suggested that you connect the RING0 line to an interrupt line of your application. In this case, the application can be designed to receive an interrupt when a falling edge on RING0 occurs. This solution is most effective, particularly, for waking up an application from power saving. Therefore, utilizing the RING0 line provides an option to significantly reduce the overall current consumption of your application.

The RING0 line behavior and usage can be configured by AT command. For details see [\[1\]](#): AT[^]SCFG.

4/ Antenna Interfaces

4.1. GSM/UMTS/LTE Antenna Interface

The ALS6A-E GSM/UMTS/LTE antenna interface comprises a GSM/UMTS/LTE main antenna as well as a UMTS/LTE Rx diversity/MIMO antenna to improve signal reliability and quality¹. The interface has an impedance of 50Ω. ALS6A-E is capable of sustaining a total mismatch at the antenna interface without any damage, even when transmitting at maximum RF power.

The external antennas must be matched properly to achieve best performance regarding radiated power, modulation accuracy and harmonic suppression. Matching networks are not included on the ALS6A-E PCB and should be placed in the host application, if the antenna does not have an impedance of 50Ω.

Regarding the return loss ALS6A-E provides the following values in the active band:

Table 12: Return loss in the active band

State of module	Return loss of module	Recommended return loss of application
Receive	≥ 8dB	≥ 12dB
Transmit	not applicable	≥ 12dB
Idle	≤ 5dB	not applicable

¹ By delivery default the UMTS/LTE Rx diversity/MIMO antenna is configured as available for the module since its usage is mandatory for LTE. Please refer to [1] for details on how to configure antenna settings.

4.1.1. Antenna Installation

The antenna is connected by soldering the antenna pads (ANT_MAIN; ANT_DRX_MIMO) and their neighboring ground pads directly to the application's PCB.

Figure 17: Antenna pads (bottom view)

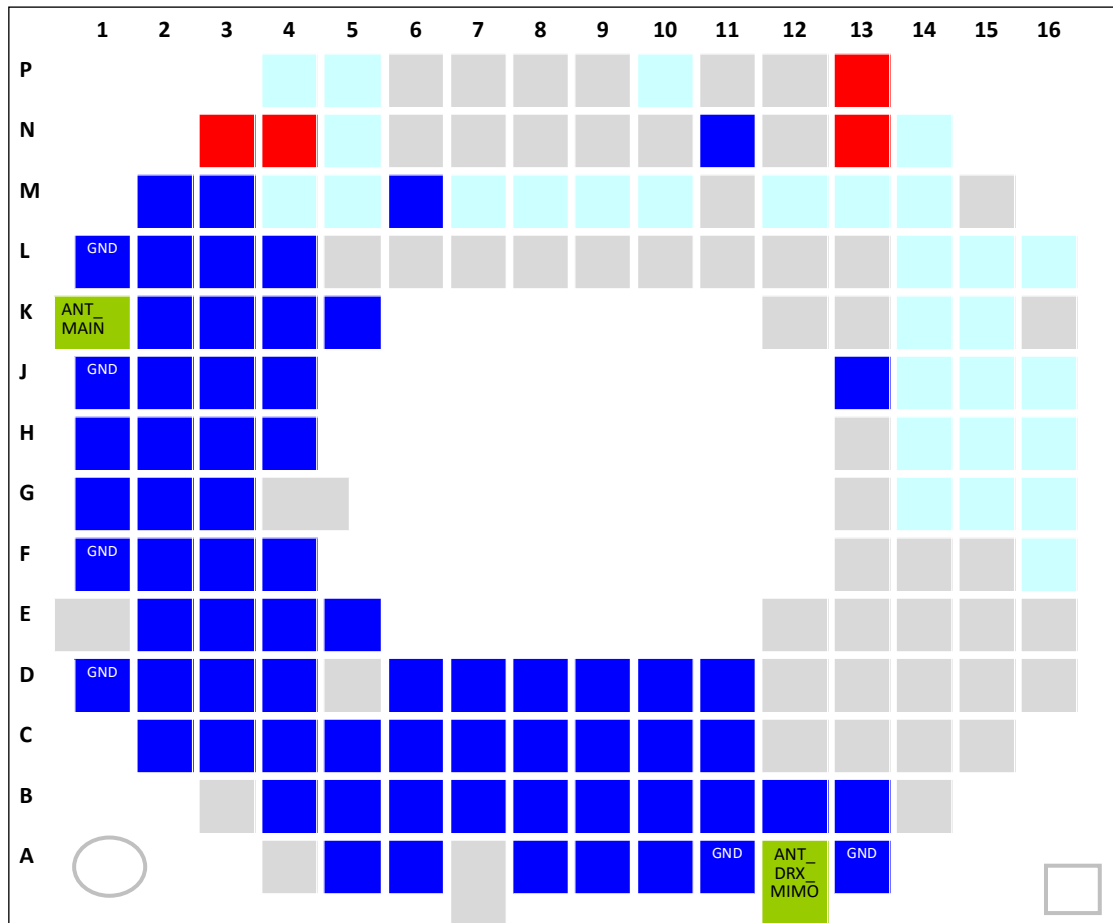

The distance between the antenna pads and their neighboring GND pads has been optimized for best possible impedance. To prevent mismatch, special attention should be paid to these pads on the application's PCB.

The wiring of the antenna connection, starting from the antenna pad to the application's antenna should result in a 50Ω line impedance. Line width and distance to the GND plane need to be optimized with regard to the PCB's layer stack. Some examples are given in [Section 4.1.2.](#)

To prevent receiver desensitization due to interferences generated by fast transients like high speed clocks on the external application PCB, it is recommended to realize the antenna connection line using embedded Stripline rather than Micro-Stripline technology. Please see [Section 4.1.2.](#) for examples of how to design the antenna connection in order to achieve the required 50Ω line impedance.

For type approval purposes, the use of a 50Ω coaxial antenna connector (U.FL-R-SMT) might be necessary. In this case the U.FL-R-SMT connector should be placed as close as possible to ALS6A-E's antenna pad.

4.1.2. RF Line Routing Design

4.1.2.1. Line Arrangement Examples

Several dedicated tools are available to calculate line arrangements for specific applications and PCB materials - for example from <http://www.polarinstruments.com/> (commercial software) or from <http://web.awrcorp.com/Usa/Products/Optional-Products/TX-Line/> (free software).

Embedded Stripline

This below figure shows line arrangement examples for embedded stripline.

Figure 18: Embedded Stripline line arrangement

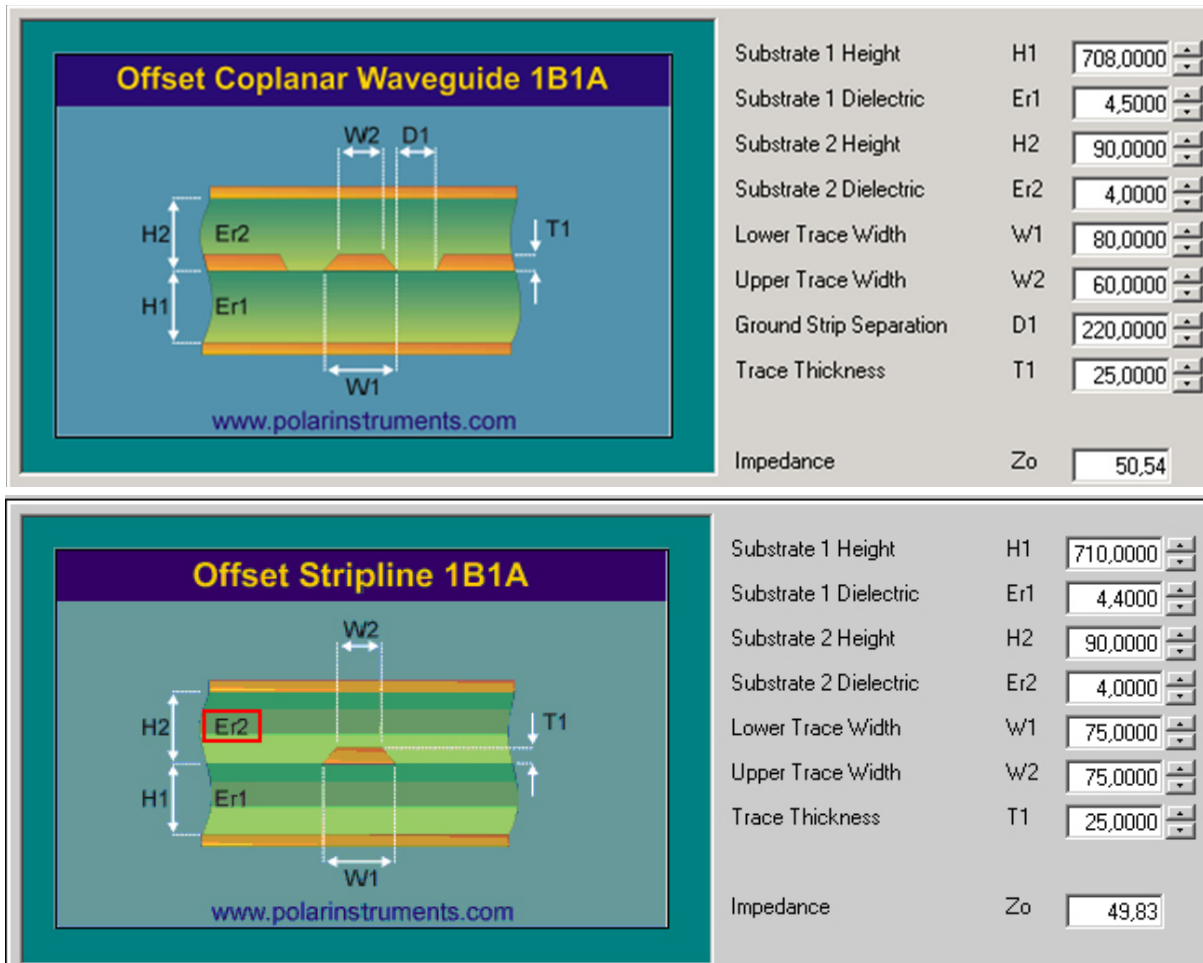

Micro-Stripline

This section gives two line arrangement examples for micro-stripline.

Figure 19: Micro-Stripline line arrangement samples

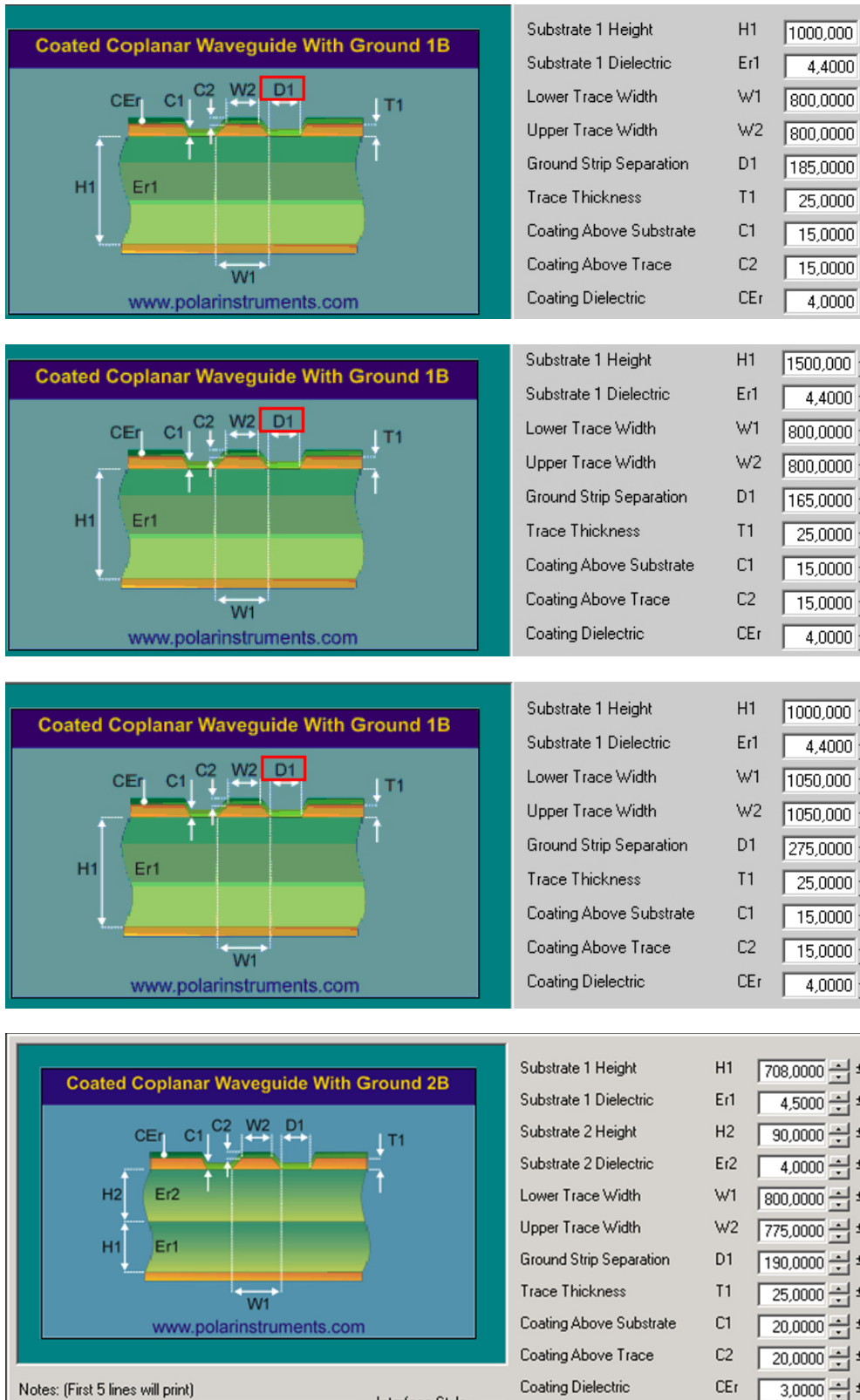

4.1.2.2. Routing Example

Interface to RF Connector

Figure 20 shows a sample connection of a module's antenna pad at the bottom layer of the module PCB with an application PCB's coaxial antenna connector. Line impedance depends on line width, but also on other PCB characteristics like dielectric, height and layer gap. The sample stripline width of 0.33mm is recommended for an application with a PCB layer stack resembling the one of the ALS6A-E evaluation board shown in Figure 21. For different layer stacks the stripline width will have to be adapted accordingly.

Figure 20: Routing to application's RF connector

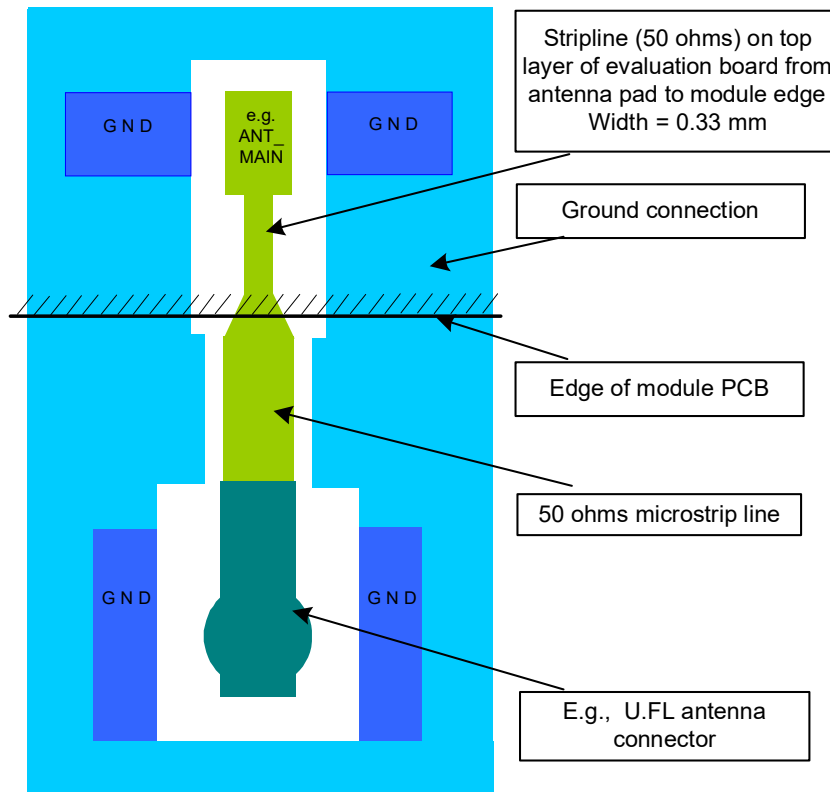

Figure 21: ALS6A-E evaluation board layer table

Layer No.	Construction	Finished thkness (um)
s/m		15
1		25
	Prepreg :1080X1 RC:64%	65
2		25
	CORE:28mil H/Hoz 7628x4	708
3		25
	Prepreg :1080X1 RC:64%	65
4		25
s/m		15
Total thickness (including S/M):		968

4.1.3. RF Antenna Diagnostic

RF antenna (GSM/UMTS/LTE) diagnosis requires the implementation of an external antenna detection circuit. An example for such a circuit is illustrated in [Figure 23](#). It allows to check the presence and the connection status of 1 or 2 RF antennas.

To properly detect the antenna and verify its connection status the antenna feed point must have a DC resistance R_{ANT} of $9k\Omega (\pm 3k\Omega)$.

A positive or negative voltage drop (referred to as $V_{disturb}$) on the ground line may occur without having any impact on the measuring procedure and the measuring result. A peak deviation ($V_{disturb}$) of $\leq 0.8V$ from ground is acceptable.

$V_{disturb}$ (peak) = $\pm 0.8V$ (maximum); $f_{disturb}$ = 0Hz ... 5kHz

Waveform: DC, sinus, square-pulse, peak-pulse (width = 100 μ s)

$R_{disturb}$ = 5 Ω

To make sure that the antenna detection operates reliably, the capacitance at the module's antenna pad (i.e., the cable capacitance plus the antenna capacitance (C_{ANT})) should not be greater than 100pF. Some types of antennas (for example "inverted F antenna" or "half loop antenna") need an RF short circuit between the antenna structure and ground to work properly. In this case the RF short circuit has to be realized via a capacitance (C_{ANT}). For C_{ANT} we recommend a capacitance lower than 100pF (see [Figure 22](#)).

Figure 22: Resistor measurement used for antenna detection

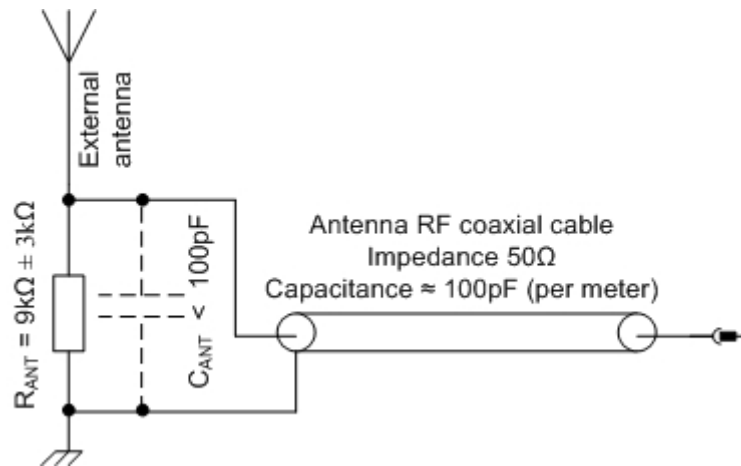
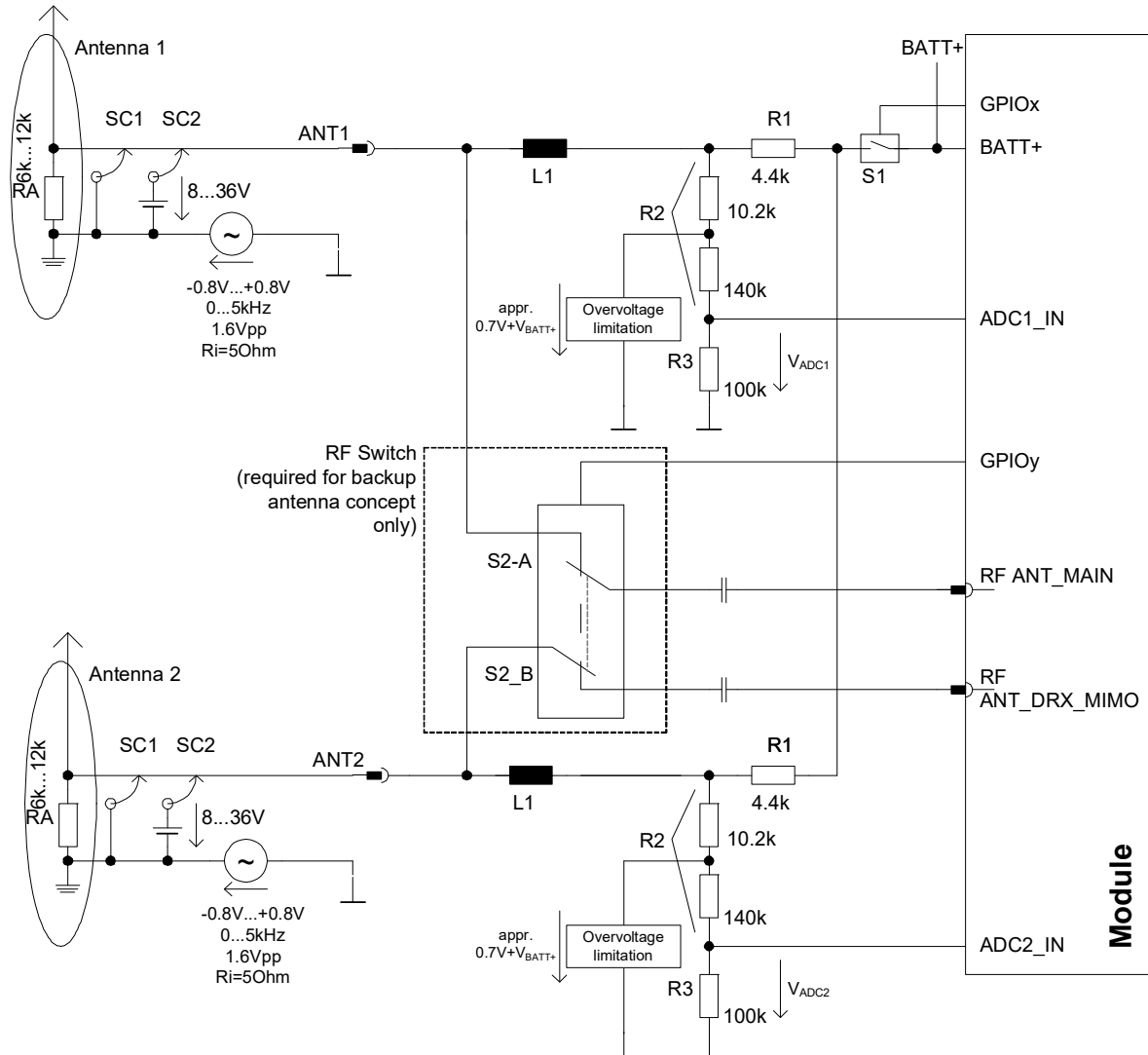

Figure 23 shows the basic principles of an antenna detection circuit that is able to detect two antennas and verify their connection status. The GPIO pads can be employed to enable the antenna detection, the ADCx_IN pads can be used to measure the voltage of external devices connected to these ADC input pads - thus determining R_{ANT} values. The AT^SRADC write command configures the parameters required for ADC measurement and returns the measurement result(s) - for command details see [1].

Figure 23: Basic layout sample for antenna detection



The following Table 13 lists possible signal states for the GPIOx and GPIOy signal lines in case these lines are configured and used for antenna detection. For GPIO configuration and control commands see [1].

Table 13: Possible GPIOx and GPIOy signal states if used for antenna diagnosis

Signal state	Meaning
GPIOx: Input Pull down or Output low Output high	Antenna detection control (S1 in above figure): Off (diagnostic measurement is off) On (diagnostic measurement is on)
GPIOy: Input Pull down or Output low Output high	Antenna switch control (RF switch in above figure): Antenna 1 Antenna 2

Table 14 lists assured antenna diagnostic states depending on the measured R_{ANT} values. Note that the R_{ANT} ranges not mentioned in the below table, i.e., 1kΩ...6kΩ and 12kΩ...40kΩ are tolerance ranges. Within these tolerance ranges a decision threshold for a diagnostic application may be located. For more details on the sample antenna detection circuit please refer to Section 7.1..

Table 14: Assured antenna diagnostic states

Antenna state	R_{ANT} range
Normal operation, antenna connected (resistance at feed point as required)	$R_{ANT} = 6k\Omega \dots 12k\Omega$
Antenna pad short-circuited to GND	$R_{ANT} = 0 \dots 1k\Omega$
Antenna not properly connected, or resistance at antenna feed point wrong or not present	$R_{ANT} = 40k\Omega \dots \infty\Omega$
Antenna pad is short-circuited to the supply voltage of the host application, for example the vehicle's on-board power supply voltage	max. 36V

Measuring procedure for the basic layout sample given in Figure 23:

The battery current flows through R1 and RA. The voltage drop on RA is divided by $R3/(R3+R2)$ and measured by the ADCx_IN input. For the ADCx_IN voltage V_{ADCx} (monitored using AT^SRADC) and the BATT+ supply voltage V_{BATT+} (monitored using AT^SBV) several measuring samples should be taken for averaging. The measured and averaged value V_{ADCx} will then be compared to three decision thresholds. The decision thresholds depend on BATT+:

Table 15: GSM/UMTS/LTE antenna diagnostic decision threshold

Decision threshold ¹		V_{ADCx}	Result
Short to GND	Appr. $0,176 * V_{BATT+}$ (580mV...738mV)	<	Short-circuited to ground
		>	Antenna connected
No antenna	Appr. $0,337 * V_{BATT+}$ (1111mV...1414mV)	<	Antenna nor properly connected
		>	
Short to power	$0.146 + 0.405 * V_{BATT+}$ (1482mV...1888mV)	<	Short-circuited to power
		>	

¹ The decision thresholds depends on BATT+ and has to be calculated separately for each decision (the BATT+ voltage level V_{BATT+} is known to the system: $3.3V \leq V_{BATT+} \leq 4.2V$).

5/ Electrical, Reliability and Radio Characteristics

5.1. Absolute Maximum Ratings

The absolute maximum ratings stated in [Table 16](#) are stress ratings under any conditions. Stresses beyond any of these limits will cause permanent damage to ALS6A-E.

Table 16: Absolute maximum ratings

Parameter	Min	Max	Unit
Supply voltage BATT+	-0.5	+6.0	V
Voltage at all digital lines in Power Down mode	-0.5	+0.5	V
Voltage at digital lines in normal operation	-0.5	+2.3	V
Voltage at SIM/USIM interface, CCVCC 1.8V in normal operation	-0.5	+2.3	V
Voltage at SIM/USIM interface, CCVCC 3.0V in normal operation	-0.5	+3.4	V
Voltage at ADC lines if the module is powered by BATT+	-0.5	+3.5	V
Voltage at ADC lines if the module is not powered	-0.5	+0.5	V
VEXT maximum current shorted to GND		-300	mA
VUSB_IN, USB_DN, USB_DP	-0.3	5.75	V
Voltage at PWR_IND line	-0.5	5.5	V
PWR_IND input current if PWR_IND= low		2	mA
Voltage at following signals: IGT, EMERG_OFF	-0.5	2.5	V

5.2. Operating Temperatures

Table 17: Board temperature

Parameter	Min	Typ	Max	Unit
Operating temperature range	-30	+25	+85	°C
Restricted temperature range ¹	-40		+95	°C
Automatic shutdown ² Temperature measured on ALS6A-E board	<-40	---	>+95	°C

¹ Restricted operation allows normal mode data transmissions for limited time until automatic thermal shutdown takes effect. Within the restricted temperature range (outside the operating temperature range) the specified electrical characteristics may be in- or decreased.

² Due to temperature measurement uncertainty, a tolerance on the stated shutdown thresholds may occur. The possible deviation is in the range of $\pm 2^\circ\text{C}$ at the overtemperature and undertemperature limit.

5.3. Storage Conditions

The conditions stated below are only valid for modules in their original packed state in weather protected, non-temperature-controlled storage locations. Normal storage time under these conditions is 12 months maximum. The modules will be delivered in a packaging that meets the requirements according "IPD/JEDEC J-STD-033B.1" for Low Temperature Carriers.

Table 18: Storage conditions

Type	Condition	Unit	Reference
Humidity relative: Low High	10 90 at 40°C	%	IPC/JEDEC J-STD-033A
Air pressure: Low High	70 106	kPa	IEC TR 60271-3-1: 1K4 IEC TR 60271-3-1: 1K4
Movement of surrounding air	1.0	m/s	IEC TR 60271-3-1: 1K4
Water: rain, dripping, icing and frosting	Not allowed	---	---
Radiation: Solar Heat	1120 600	W/m ²	ETS 300 019-2-1: T1.2, IEC 60068-2-2 Bb ETS 300 019-2-1: T1.2, IEC 60068-2-2 Bb
Chemically active substances	Not recommended		IEC TR 60271-3-1: 1C1L
Mechanically active substances	Not recommended		IEC TR 60271-3-1: 1S1
Vibration sinusoidal: Displacement Acceleration Frequency range	1.5 5 2-9 9-200	mm m/s ² Hz	IEC TR 60271-3-1: 1M2
Shocks: Shock spectrum Duration Acceleration	Semi-sinusoidal 1 50	ms m/s ²	IEC 60068-2-27 Ea

5.4. Reliability Characteristics

The test conditions stated below are an extract of the complete test specifications.

Table 19: Summary of reliability test conditions

Type of test	Conditions	Standard
Vibration	Frequency range: 10-20Hz; acceleration: 5g Frequency range: 20-500Hz; acceleration: 20g Duration: 20h per axis; 3 axes	DIN IEC 60068-2-6 ¹
Shock half-sinus	Acceleration: 500g Shock duration: 1ms 1 shock per axis 6 positions (\pm x, y and z)	DIN IEC 60068-2-27
Dry heat	Temperature: $+70 \pm 2^\circ\text{C}$ Test duration: 16h Humidity in the test chamber: < 50%	EN 60068-2-2 Bb ETS 300 019-2-7
Temperature change (shock)	Low temperature: $-40^\circ\text{C} \pm 2^\circ\text{C}$ High temperature: $+85^\circ\text{C} \pm 2^\circ\text{C}$ Changeover time: < 30s (dual chamber system) Test duration: 1h Number of repetitions: 100	DIN IEC 60068-2-14 Na ETS 300 019-2-7
Damp heat cyclic	High temperature: $+55^\circ\text{C} \pm 2^\circ\text{C}$ Low temperature: $+25^\circ\text{C} \pm 2^\circ\text{C}$ Humidity: 93% \pm 3% Number of repetitions: 6 Test duration: 12h + 12h	DIN IEC 60068-2-30 Db ETS 300 019-2-5
Cold (constant exposure)	Temperature: $-40 \pm 2^\circ\text{C}$ Test duration: 16h	DIN IEC 60068-2-1

¹ For reliability tests in the frequency range 20-500Hz the Standard's acceleration reference value was increased to 20g.

5.4.1. Bending Tests

From experience with other modules an elongation of up to $200\mu\text{m}/\text{m}$ is acceptable for ALS6A-E modules as a result of bending strains.

Tests (based on EN 60068-2-21) showed that if applying a force of 10N at the middle of the module, i.e., the evaluation module with the actual ALS6A-E module soldered onto the evaluation PCB as shown in [Figure 24](#), the possible elongation is clearly below the value of $200\mu\text{m}/\text{m}$. Therefore, a force of 10N is recommended as maximum force.

Please note that these values only apply for a one-off short stress. The module will have to be mounted free of any strains and without being exposed to dynamic pressures.

Figure 24: Bending test setup

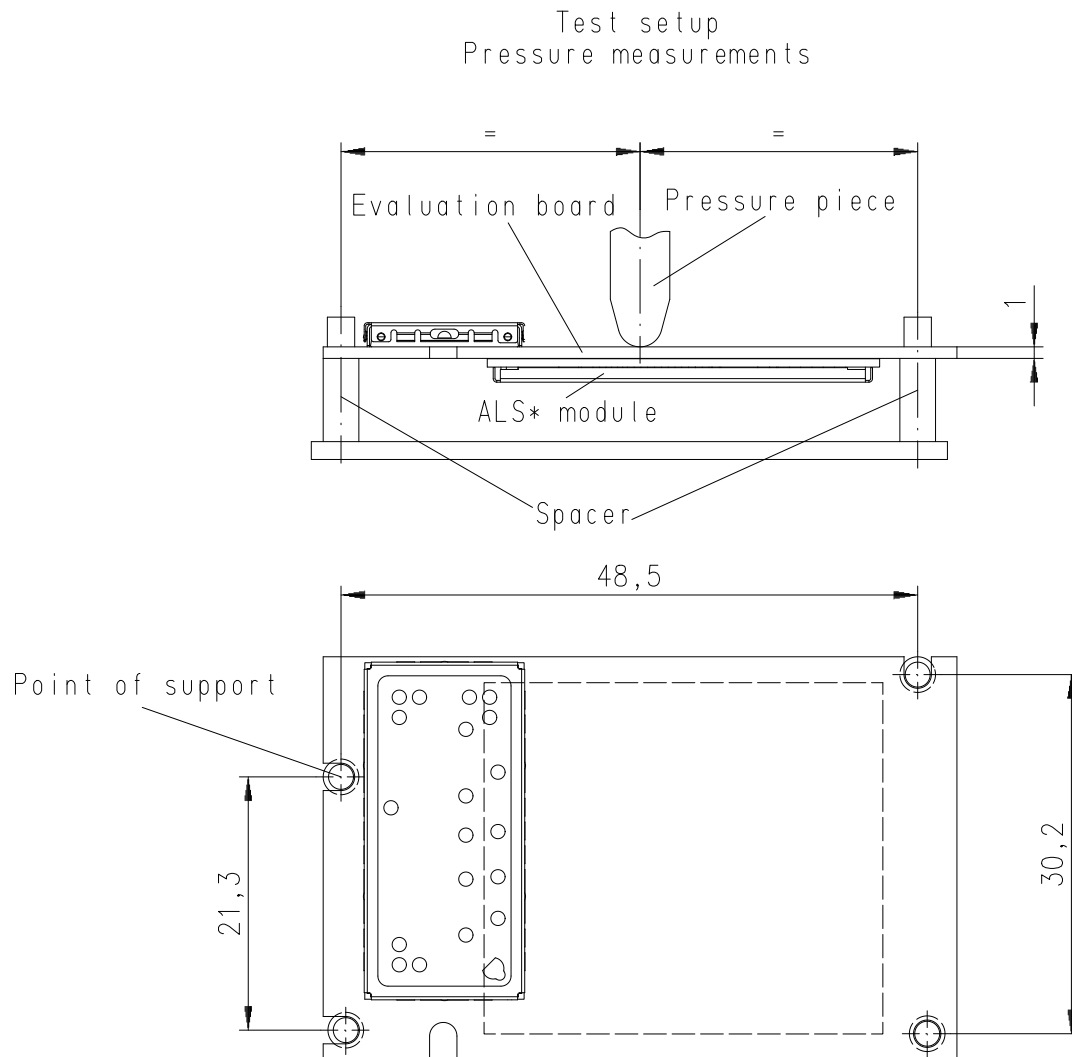

5.5. Pad Assignment and Signal Description

The SMT application interface on the ALS6A-E provides connecting pads to integrate the module into external applications. Table 20 lists the pads' assignments. Figure 25 (bottom view) and Figure 26 (top view) show the connecting pads' numbering plan.

Please note that pads marked "rfu" (reserved for future use) and further qualified as "dnu" (do not use) may be soldered but should not be connected to an external application.

Kontron strongly recommends to solder all connecting pads for mechanical stability and heat dissipation.

Table 20: Overview: Pad assignments¹

Pad No.	Signal Name	Pad No.	Signal Name	Pad No.	Signal Name
A4	nc	E2	GND	L2	GND
A5	GND	E3	GND	L3	GND
A6	GND	E4	GND	L4	GND
A7	rfu (dnu)	E5	GND	L5	rfu (dnu)
A8	GND	E12	rfu (dnu)	L6	rfu (dnu)
A9	GND	E13	rfu (dnu)	L7	rfu (dnu)
A10	GND	E14	rfu (dnu)	L8	rfu (dnu)
A11	GND	E15	rfu (dnu)	L9	rfu (dnu)
A12	ANT_DRX_MIMO	E16	rfu (dnu)	L10	rfu (dnu)
A13	GND	F1	GND	L11	rfu (dnu)
B3	nc	F2	GND	L12	rfu (dnu)
B4	GND	F3	GND	L13	rfu (dnu)
B5	GND	F4	GND	L14	CCRST
B6	GND	F13	rfu (dnu)	L15	CCCLK
B7	GND	F14	rfu (dnu)	L16	IGT
B8	GND	F15	rfu (dnu)	M2	GND
B9	GND	F16	GPIO10	M3	GND
B10	GND	G1	GND	M4	PWR_IND
B11	GND	G2	GND	M5	VEXT
B12	GND	G3	GND	M6	GND
B13	GND	G4	rfu (dnu)	M7	PCM_IN
B14	rfu (dnu)	G13	rfu (dnu)	M8	PCM_CLK
C2	GND	G14	GPIO7	M9	PCM_FSC
C3	GND	G15	GPIO8	M10	PCM_OUT
C4	GND	G16	GPIO9	M11	rfu (dnu)
C5	GND	H1	GND	M12	ADC2_IN
C6	GND	H2	GND	M13	ADC1_IN
C7	GND	H3	GND	M14	CCIN
C8	GND	H4	GND	M15	rfu (dnu)
C9	GND	H13	rfu (dnu)	N3	BATT+_RF
C10	GND	H14	GPIO4	N4	BATT+_RF
C11	GND	H15	GPIO5	N5	VUSB_IN
C12	rfu (dnu)	H16	GPIO6	N6	rfu (dnu)
C13	rfu (dnu)	J1	GND	N7	rfu (dnu)
C14	rfu (dnu)	J2	GND	N8	rfu (dnu)
C15	rfu (dnu)	J3	GND	N9	rfu (dnu)
D1	GND	J4	GND	N10	rfu (dnu)
D2	GND	J13	GND	N11	GND
D3	GND	J14	GPIO1	N12	rfu (dnu)
D4	GND	J15	GPIO2	N13	BATT+
D5	rfu (dnu)	J16	GPIO3	N14	EMERG_OFF
D6	GND	K1	ANT_MAIN	P4	USB_DP
D7	GND	K2	GND	P5	USB_DN
D8	GND	K3	GND	P6	rfu (dnu)
D9	GND	K4	GND	P7	rfu (dnu)
D10	GND	K5	GND	P8	rfu (dnu)
D11	GND	K12	rfu (dnu)	P9	rfu (dnu)
D12	rfu (dnu)	K13	rfu (dnu)	P10	RINGO
D13	rfu (dnu)	K14	CCIO	P11	rfu (dnu)
D14	rfu (dnu)	K15	CCVCC	P12	rfu (dnu)
D15	rfu (dnu)	K16	rfu (dnu)	P13	BATT+
D16	rfu (dnu)	L1	GND		
E1	rfu (dnu)				

¹ nc = not connected; rfu = reserved for future use; dnu = do not use

Figure 25: ALS6A-E bottom view: Pad assignments

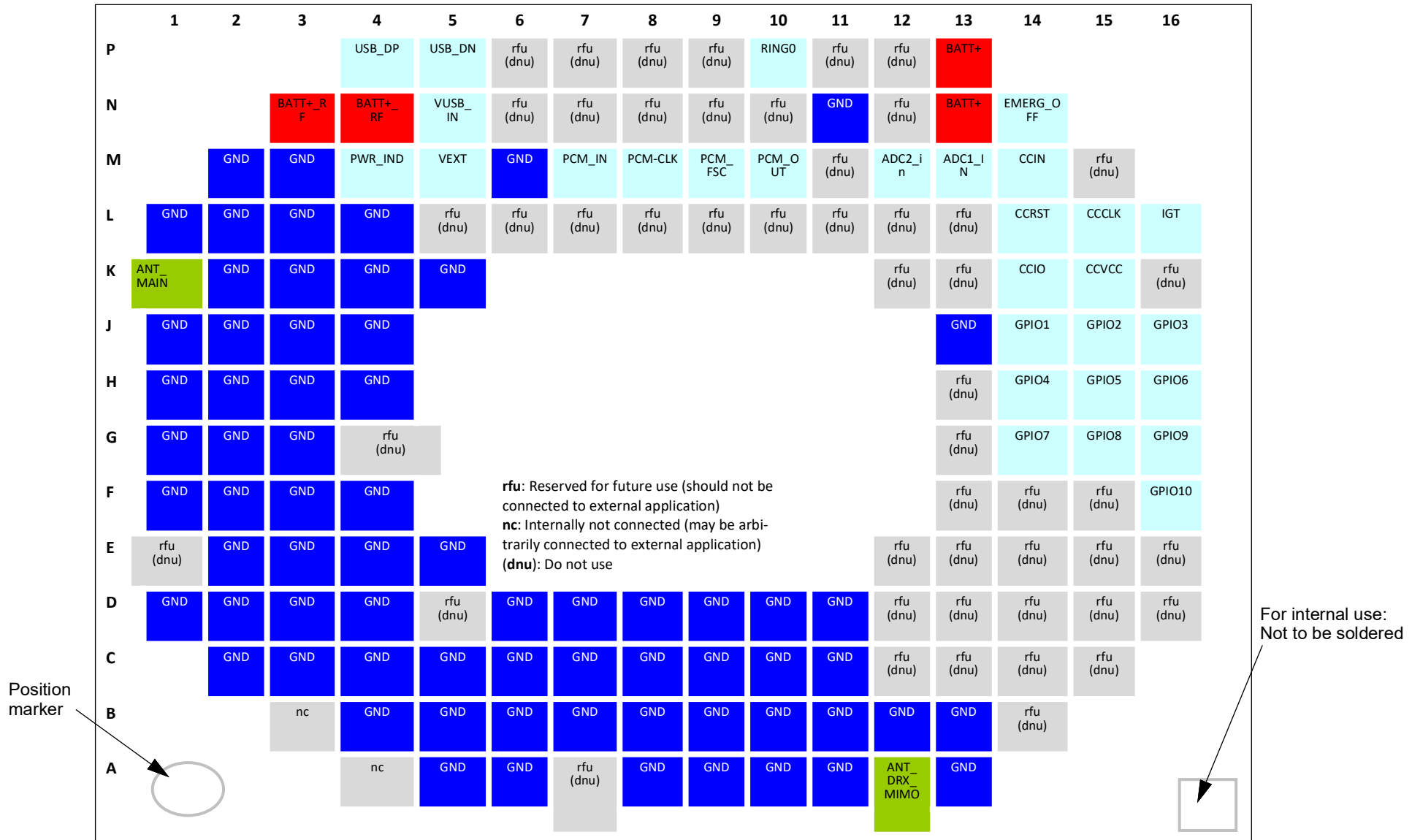
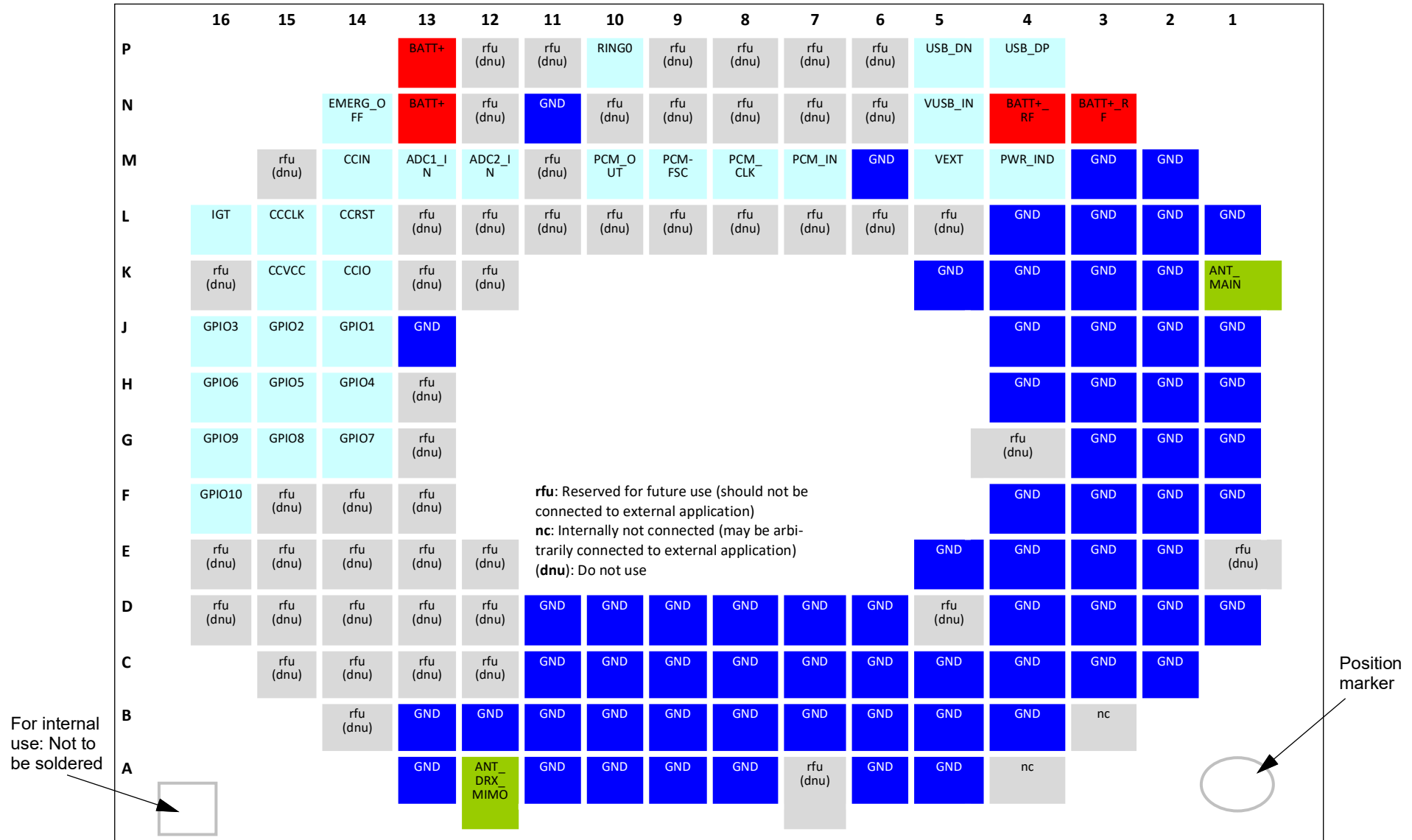

Figure 26: ALS6A-E top view: Pad assignments



Please note that the reference voltages listed in Table 21 are the values measured directly on the ALS6A-E module. They do not apply to the accessories connected.

Table 21: Signal description

Function	Signal name	IO	Signal form and level	Comment
Power supply	BATT+_RF	I	$V_{i,max} = 4.2V$ $V_{i,norm} = 3.8V$ $V_{i,min} = 3.3V$ during Tx burst on board $I_{max} \approx 2A$, during Tx burst (GSM)	Lines of BATT+ and GND must be connected in parallel for supply purposes because higher peak currents may occur. Minimum voltage must not fall below 3.3V including drop, ripple, spikes.
	BATT+	I	$V_{i,max} = 4.2V$ $V_{i,norm} = 3.8V$ $V_{i,min} = 3.3V$ during Tx burst on board $I_{max} = 350mA$	
Power supply	GND		Ground	Application Ground
External supply voltage	VEXT	O	$CL_{max} = 1\mu F$ $V_O = 1.80V +1\% -5\%$ $I_{O,max} = -50mA$	VEXT may be used for application circuits. If unused keep line open. The external digital logic must not cause any spikes or glitches on voltage VEXT. Do not exceed $I_{O,max}$
Ignition	IGT	I	$R_{PU} \approx 200k\Omega$ $V_{OH,max} = 1.8V$ $V_{IH,max} = 2.1V$ $V_{IH,min} = 1.17V$ $V_{IL,max} = 300mV$ Low impulse width > 100ms	This signal switches the module ON. It is recommended to drive this line low by an open drain or open collector driver connected to GND.
Emergency off	EMERG_OFF	I	$R_{PU} \approx 40k\Omega$ $V_{OH,max} = 1.8V$ $V_{IH,max} = 2.1V$ $V_{IH,min} = 1.17V$ $V_{IL,max} = 300mV$ $\sim\sim \underline{\quad} \sim\sim$ low impulse width > 40ms	It is recommended to drive this line low by an open drain or open collector driver connected to GND. If unused keep line open.
SIM card detection	CCIN	I	$R_{PU} \approx 24.2k\Omega$ $V_{OH,max} = 1.9V$ $V_{IH,min} = 1.15V$ $V_{IH,max} = 1.9V$ $V_{IL,max} = 0.4V$	CCIN = Low, SIM card inserted. If unused connect to GND.

Table 21: Signal description

Function	Signal name	IO	Signal form and level	Comment
3V SIM card interface	CCRST	O	$V_{OLmax} = 0.45V$ at $I = 2mA$ $V_{OHmin} = 2.57V$ at $I = -2mA$ $V_{OHmax} = 3.08V$	Maximum cable length or copper track should be not longer than 100mm to SIM card holder.
	CCIO	I/O	$R_{PU} \approx 4.8...9.5k\Omega$ $V_{ILmax} = 0.76V$ $V_{ILmin} = -0.3V$ $V_{IHmin} = 1.98V$ $V_{IHmax} = 3.35V$ $V_{OLmax} = 0.45V$ at $I = 2mA$ $V_{OHmin} = 2.57V$ at $I = -0.05mA$ $V_{OHmax} = 3.08V$	
	CCCLK	O	$V_{OLmax} = 0.45V$ at $I = 2mA$ $V_{OHmin} = 2.57V$ at $I = -2mA$ $V_{OHmax} = 3.08V$	
	CCVCC	O	$V_{Omin} = 3.0V$ $V_{Otyp} = 3.05V$ $V_{Omax} = 3.08V$ $I_{Omax} = -50mA$	
1.8V SIM card interface	CCRST	O	$V_{OLmax} = 0.45V$ at $I = 2mA$ $V_{OHmin} = 1.35V$ at $I = -2mA$ $V_{OHmax} = 1.85V$	Maximum cable length or copper track should be not longer than 100mm to SIM card holder.
	CCIO	I/O	$R_I \approx 4.8...9.5k\Omega$ $V_{ILmax} = 0.62V$ $V_{ILmin} = -0.3V$ $V_{IHmin} = 1.20V$ $V_{IHmax} = 2.1V$ $V_{OLmax} = 0.45V$ at $I = 2mA$ $V_{OHmin} = 1.32V$ at $I = -0.05mA$ $V_{OHmax} = 1.82V$	
	CCCLK	O	$V_{OLmax} = 0.45V$ at $I = 2mA$ $V_{OHmin} = 1.32V$ at $I = -2mA$ $V_{OHmax} = 1.82V$	
	CCVCC	O	$V_{Omin} = 1.75V$ $V_{Otyp} = 1.80V$ $V_{Omax} = 1.82V$ $I_{Omax} = -50mA$	
Power indicator	PWR_IND	O	$V_{IHmax} = 5.5V$ $V_{OLmax} = 0.4V$ at $I_{max} = 1mA$	<p>PWR_IND (Power Indicator) notifies the module's on/off state.</p> <p>PWR_IND is an open collector that needs to be connected to an external pull-up resistor. Low state of the open collector indicates that the module is on. Vice versa, high level notifies the Power Down mode.</p> <p>Therefore, signal may be used to enable external vol-tage regulators that supply an external logic for communication with the module, e.g. level converters.</p>
Host wakeup	RINGO	O	$V_{OLmax} = 0.45V$ at $I = 2mA$ $V_{OHmin} = 1.35V$ at $I = -2mA$ $V_{OHmax} = 1.85V$	If unused keep line open.

Table 21: Signal description

Function	Signal name	IO	Signal form and level	Comment
USB	VUSB_IN	I	$V_{IN,min} = 3.0V$ $V_{IN,max} = 5.25V$ $I_{I,typ} = 150\mu A$ $I_{I,max} = 200\mu A$ $C_{in} = 1\mu F$ In case of $V_{ripple} \geq 10mV_{pp}$ (with $f > 300kHz$), and V_{BUS_IN} driven in the voltage range 4.08V...4.11V, use of an RC filter 1k Ω /100nF is required.	If the USB interface is not used please connect this line to GND. Since VUSB_IN is used for detection only it is recommended not to add any further blocking capacitors on the VUSB_IN line.
	USB_DN	I/O	All electrical characteristics according to USB Implementers' Forum, USB 2.0 High Speed Specification.	Keep lines open if VUSB_IN connects to GND. USB High Speed mode operation requires a differential impedance of 90 Ω .
	USB_DP	I/O		
Digital audio interface (PCM)	PCM_IN	I	$V_{IL,max} = 0.6V$ at 30 μA $V_{IH,min} = 1.20V$ at -30 μA $V_{IH,max} = 2V$ $V_{OL,max} = 0.45V$ at $I = 2mA$ $V_{OH,min} = 1.35V$ at $I = -2mA$ $V_{OH,max} = 1.85V$	PCM Master mode. If unused keep lines open.
	PCM_CLK	I/O		
	PCM_FSC	I/O		
	PCM_OUT	O		
GPIO interface	GPIO1 GPIO2 GPIO3 GPIO4 GPIO5 GPIO6 GPIO7 GPIO8 GPIO9 GPIO10	I/O	$V_{IL,max} = 0.6V$ at 30 μA $V_{IH,min} = 1.20V$ at -30 μA $V_{IH,max} = 2V$ $V_{OL,max} = 0.45V$ at $I = 2mA$ $V_{OH,min} = 1.35V$ at $I = -2mA$ $V_{OH,max} = 1.85V$	If unused keep lines open.
ADC interface	ADC1_IN, ADC2_IN	I	Full specification compliance range $V_{Imin} \geq 0.3V$ $V_{Imax} \leq 3.075V$ Degraded accuracy range $V_{Imin} 0.05V \dots 0.3V$ $R_{idc} > 1M\Omega$ Resolution: 12 Bit Offset error: $\pm 10mV$ Gain error: $< 1\%$ analog bandwidth: $< 16kHz$ conversation time: 853 μs	If unused keep line open. Prepared for general purpose and antenna diagnostic use.

5.6. Power Supply Ratings

Table 22 and Table 23 assemble various voltage supply and current consumption ratings of the module.

Table 22: Voltage supply ratings

	Description	Conditions	Min	Typ	Max	Unit
BATT+	Supply voltage	Directly measured at Module. Voltage must stay within the min/max values, including voltage drop, ripple, spikes	3.3	3.8	4.2	V
	Maximum allowed voltage drop during transmit burst	Normal condition, power control level for Pout max			400	mV
	Voltage ripple	Normal condition, power control level for Pout max @ f ≤ 250 kHz @ f > 250 kHz			120 90	mV _{pp} mV _{pp}

Table 23: Current consumption ratings

	Description	Conditions	Typical rating	Unit	
I _{BATT+} ¹	OFF State supply current	Power Down	40	μA	
	Average GSM / GPRS supply current	SLEEP ² @ DRX=9	USB disconnected	2.0	mA
		SLEEP ² @ DRX=5	USB disconnected	2.5	mA
		SLEEP ² @ DRX=2	USB disconnected	3.7	mA
		IDLE @ DRX=2	USB disconnected	75	mA
			USB active	90	mA
		Voice call GSM900; PCL=5	@50Ω	330	mA
		GPRS Data transfer GSM900; PCL=5; 1Tx/4Rx	ROPR=8 (max. reduction)	320	mA
			ROPR=4 (no reduction)		
		GPRS Data transfer GSM900; PCL=5; 2Tx/3Rx	ROPR=8 (max. reduction)	430	mA
			ROPR=4 (no reduction)	540	
	GPRS Data transfer GSM900; PCL=5; 4Tx/1Rx	ROPR=8 (max. reduction)	600	mA	
		ROPR=4 (no reduction)	930		

Table 23: Current consumption ratings

	Description	Conditions	Typical rating	Unit	
I _{BATT+} ¹	Average GSM / GPRS supply current	EDGE Data transfer GSM900; PCL=5; 1Tx/4Rx	ROPR=8 (max. reduction)	220	mA
			ROPR=4 (no reduction)		
		EDGE Data transfer GSM900; PCL=5; 2Tx/3Rx	ROPR=8 (max. reduction)	300	mA
			ROPR=4 (no reduction)	340	
		EDGE Data transfer GSM900; PCL=5; 4Tx/1Rx	ROPR=8 (max. reduction)	490	mA
			ROPR=4 (no reduction)	570	
		Voice call GSM1800; PCL=0	@50Ω	240	mA
		GPRS Data transfer GSM1800; PCL=0; 1Tx/4Rx	ROPR=8 (max. reduction)	230	mA
			ROPR=4 (no reduction)		
		GPRS Data transfer GSM1800; PCL=0; 2Tx/3Rx	ROPR=8 (max. reduction)	300	mA
			ROPR=4 (no reduction)	360	
		GPRS Data transfer GSM1800; PCL=0; 4Tx/1Rx	ROPR=8 (max. reduction)	410	mA
			ROPR=4 (no reduction)	590	
		EDGE Data transfer GSM1800; PCL=0; 1Tx/4Rx	ROPR=8 (max. reduction)	190	mA
			ROPR=4 (no reduction)		
		EDGE Data transfer GSM1800; PCL=0; 2Tx/3Rx	ROPR=8 (max. reduction)	250	mA
			ROPR=4 (no reduction)	290	
		EDGE Data transfer GSM1800; PCL=0; 4Tx/1Rx	ROPR=8 (max. reduction)	380	mA
			ROPR=4 (no reduction)	460	
		Peak current during GSM transmit burst	Voice call GSM900; PCL=5	@50Ω	2.1
@total mismatch	2.4				
Voice call GSM1800; PCL=0	@50Ω		1.3	A	
	@total mismatch		1.6		

Table 23: Current consumption ratings

	Description	Conditions	Typical rating	Unit		
$I_{\text{BATT+}}$ ¹	Average UMTS supply current	SLEEP ² @ DRX=9	USB disconnected	1.8	mA	
		SLEEP ² @ DRX=8	USB disconnected	2.1	mA	
	Voice calls and Data transfers measured @maximum Pout	SLEEP ² @ DRX=6	USB disconnected	3.3	mA	
		IDLE @ DRX=6	USB disconnected	50	mA	
			USB active	65	mA	
		Voice call Band I		540	mA	
		Voice call Band III	@50Ω	600	mA	
			@total mismatch	780		
		Voice call Band VIII		460	mA	
		UMTS Data transfer Band I		560	mA	
		UMTS Data transfer Band III		620	mA	
		UMTS Data transfer Band VIII		500	mA	
		HSDPA Data transfer Band I		590	mA	
		HSDPA Data transfer Band III		620	mA	
		HSDPA Data transfer Band VIII		510	mA	
		Average LTE supply current ³	Data transfers measured @maximum Pout	SLEEP ² @ "Paging Occasions" = 256	USB disconnected	2.3
	SLEEP ² @ "Paging Occasions" = 128			USB disconnected	2.7	mA
	SLEEP ² @ "Paging Occasions" = 64		USB disconnected	3.5	mA	
	SLEEP ² @ "Paging Occasions" = 32		USB disconnected	5.4	mA	
	IDLE		USB disconnected	55	mA	
USB active			70	mA		
LTE Data transfer Band 1			570	mA		
LTE Data transfer Band 3	@ 50Ω		650	mA		
	@ total mismatch		830	mA		
LTE Data transfer Band 7			640	mA		
LTE Data transfer Band 8			520	mA		
LTE Data transfer Band 20			520	mA		
$I_{\text{VUSB_IN}}$	USB typical and maximum ratings are mentioned in Table 21: VUSB_IN .					

¹ With an impedance of $Z_{\text{LOAD}}=50\Omega$ at the antenna pads. Measured at 25°C and 4.2V - except for Power Down ratings that were measured at 3.4V.

² Measurements start 6 minutes after switching ON the module,
Averaging times: SLEEP mode - 3 minutes, transfer modes - 1.5 minutes
Communication tester settings: no neighbour cells, no cell reselection etc,
RMC (Reference Measurement Channel)

³ Communication tester settings:
- Channel Bandwidth: 5MHz
- Number of Resource Blocks: 25 (DL), 1 (UL)
- Modulation: QPSK

5.7. RF Antenna Interface Characteristics

Table 24: RF Antenna interface GSM / UMTS/LTE (at operating temperature range¹)

Parameter	Conditions	Min.	Typical	Max.	Unit
LTE connectivity ²	Band 1, 3, 7, 8, 20				
Receiver Input Sensitivity @ ARP (ch. bandwidth 5MHz)	LTE 800 Band 20	-97	-103		dBm
	LTE 900 Band 8	-97	-104		dBm
	LTE 1800 Band 3	-97	-103		dBm
	LTE 2100 Band 1	-100	-103		dBm
	LTE 2600 Band 7	-98	-102		dBm
RF Power @ ARP with 50Ω Load	LTE 800 Band 20	+21	+23	+25	dBm
	LTE 900 Band 8	+21	+23	+25	dBm
	LTE 1800 Band 3	+21	+23	+25	dBm
	LTE 2100 Band 1	+21	+23	+25	dBm
	LTE 2600 Band 7	+21	+23	+25	dBm
UMTS/HSPA connectivity ²	Band I, III, VIII				
Receiver Input Sensitivity @ ARP	UMTS 900 Band VIII	-103.7	-111		dBm
	UMTS 1800 Band III	-103.7	-110		dBm
	UMTS 2100 Band I	-106.7	-110		dBm
RF Power @ ARP with 50Ω Load	UMTS 900 Band VIII	+21	+24	+25	dBm
	UMTS 1800 Band III	+21	+24	+25	dBm
	UMTS 2100 Band I	+21	+24	+25	dBm
GPRS coding schemes	Class 12, CS1 to CS4				
EGPRS	Class 12, MCS1 to MCS9				
GSM Class	Small MS				
Static Receiver input Sensitivity @ ARP	E-GSM 900	-102	-111		dBm
	GSM 1800	-102	-110		dBm
RF Power @ ARP with 50Ω Load GSM	E-GSM 900		33		dBm
	GSM 1800		30		dBm

Table 24: RF Antenna interface GSM / UMTS/LTE (at operating temperature range¹)

Parameter		Conditions	Min.	Typical	Max.	Unit
RF Power @ ARP with 50Ω Load (ROPR=4, i.e., no reduction)	GPRS, 1 TX	E-GSM 900		33		dBm
		GSM 1800		30		dBm
	EDGE, 1 TX	E-GSM 900		27		dBm
		GSM 1800		26		dBm
	GPRS, 2 TX	E-GSM 900		33		dBm
		GSM 1800		30		dBm
	EDGE, 2 TX	E-GSM 900		27		dBm
		GSM 1800		26		dBm
	GPRS, 3 TX	E-GSM 900		33		dBm
		GSM 1800		30		dBm
	EDGE, 3 TX	E-GSM 900		27		dBm
		GSM 1800		26		dBm
	GPRS, 4 TX	E-GSM 900		33		dBm
		GSM 1800		30		dBm
	EDGE, 4 TX	E-GSM 900		27		dBm
		GSM 1800		26		dBm
RF Power @ ARP with 50Ω Load (ROPR=5)	GPRS, 1 TX	E-GSM 900		33		dBm
		GSM 1800		30		dBm
	EDGE, 1 TX	E-GSM 900		27		dBm
		GSM 1800		26		dBm
	GPRS, 2 TX	E-GSM 900		33		dBm
		GSM 1800		30		dBm
	EDGE, 2 TX	E-GSM 900		27		dBm
		GSM 1800		26		dBm
	GPRS, 3 TX	E-GSM 900		32.2		dBm
		GSM 1800		29.2		dBm
	EDGE, 3 TX	E-GSM 900		27		dBm
		GSM 1800		26		dBm
	GPRS, 4 TX	E-GSM 900		31		dBm
		GSM 1800		28		dBm
	EDGE, 4 TX	E-GSM 900		27		dBm
		GSM 1800		26		dBm

Table 24: RF Antenna interface GSM / UMTS/LTE (at operating temperature range¹)

Parameter		Conditions	Min.	Typical	Max.	Unit	
RF Power @ ARP with 50Ω Load (ROPR=6)	GPRS, 1 TX	E-GSM 900		33		dBm	
		GSM 1800		30		dBm	
	EDGE, 1 TX	E-GSM 900		27		dBm	
		GSM 1800		26		dBm	
	GPRS, 2 TX	E-GSM 900		31		dBm	
		GSM 1800		28		dBm	
	EDGE, 2 TX	E-GSM 900		27		dBm	
		GSM 1800		26		dBm	
	GPRS, 3 TX	E-GSM 900		30.2		dBm	
		GSM 1800		27.2		dBm	
	EDGE, 3 TX	E-GSM 900		27		dBm	
		GSM 1800		26		dBm	
	GPRS, 4 TX	E-GSM 900		29		dBm	
		GSM 1800		26		dBm	
	EDGE, 4 TX	E-GSM 900		27		dBm	
		GSM 1800		26		dBm	
	RF Power @ ARP with 50Ω Load (ROPR=7)	GPRS, 1 TX	E-GSM 900		33		dBm
			GSM 1800		30		dBm
EDGE, 1 TX		E-GSM 900		27		dBm	
		GSM 1800		26		dBm	
GPRS, 2 TX		E-GSM 900		30		dBm	
		GSM 1800		27		dBm	
EDGE, 2 TX		E-GSM 900		27		dBm	
		GSM 1800		26		dBm	
GPRS, 3 TX		E-GSM 900		28.2		dBm	
		GSM 1800		25.2		dBm	
EDGE, 3 TX		E-GSM 900		27		dBm	
		GSM 1800		26		dBm	
GPRS, 4 TX		E-GSM 900		27		dBm	
		GSM 1800		24		dBm	
EDGE, 4 TX		E-GSM 900		27		dBm	
		GSM 1800		26		dBm	

Table 24: RF Antenna interface GSM / UMTS/LTE (at operating temperature range¹)

Parameter		Conditions	Min.	Typical	Max.	Unit
RF Power @ ARP with 50Ω Load (ROPR=8, i.e., max. reduction)	GPRS, 1 TX	E-GSM 900		33		dBm
		GSM 1800		30		dBm
	EDGE, 1 TX	E-GSM 900		27		dBm
		GSM 1800		26		dBm
	GPRS, 2 TX	E-GSM 900		30		dBm
		GSM 1800		27		dBm
	EDGE, 2 TX	E-GSM 900		24		dBm
		GSM 1800		23		dBm
	GPRS, 3 TX	E-GSM 900		28.2		dBm
		GSM 1800		25.2		dBm
	EDGE, 3 TX	E-GSM 900		22.2		dBm
		GSM 1800		21.2		dBm
	GPRS, 4 TX	E-GSM 900		27		dBm
		GSM 1800		24		dBm
	EDGE, 4 TX	E-GSM 900		21		dBm
		GSM 1800		20		dBm

¹ At restricted temperature range no active power reduction is implemented - any deviations are hardware related.

² Applies also to UMTS/LTE Rx diversity/MIMO antenna.

5.8. Electrostatic Discharge

The module is not protected against Electrostatic Discharge (ESD) in general. Consequently, it is subject to ESD handling precautions that typically apply to ESD sensitive components. Proper ESD handling and packaging procedures must be applied throughout the processing, handling and operation of any application that incorporates a ALS6A-E module.

Special ESD protection provided on ALS6A-E:

BATT+: Inductor/capacitor

An example for an enhanced ESD protection for the SIM interface is shown in [Section 3.6.1.](#)

The remaining interfaces of ALS6A-E with the exception of the antenna interface are not accessible to the user of the final product (since they are installed within the device) and are therefore only protected according to the ANSI/ESDA/JEDEC JS-001-2011 requirements.

ALS6A-E has been tested according to the following standards. Electrostatic values can be gathered from the following table.

Table 25: Electrostatic values

Specification / Requirements	Contact discharge	Air discharge
<i>ANSI/ESDA/JEDEC JS-001-2011</i>		
All SMT interfaces	± 1kV Human Body Model	n.a.
<i>JESD22-A114-F</i>		
All SMT interfaces	± 500V Charge Device Model (CDM)	n.a.
<i>ETSI EN 301 489-1/7</i>		
BATT+	± 4kV	± 8kV

Note: The values may vary with the individual application design. For example, it matters whether or not the application platform is grounded over external devices like a computer or other equipment, such as the Kontron reference application described in [Chapter 8/](#).

6/ Mechanics, Mounting and Packaging

6.1. Mechanical Dimensions of ALS6A-E

Figure 27 shows a 3D view¹ of ALS6A-E and provides an overview of the board's mechanical dimensions. For further details see Figure 28.

Length: 33mm
 Width: 29mm
 Height: 2.2mm

Figure 27: ALS6A-E – top and bottom view

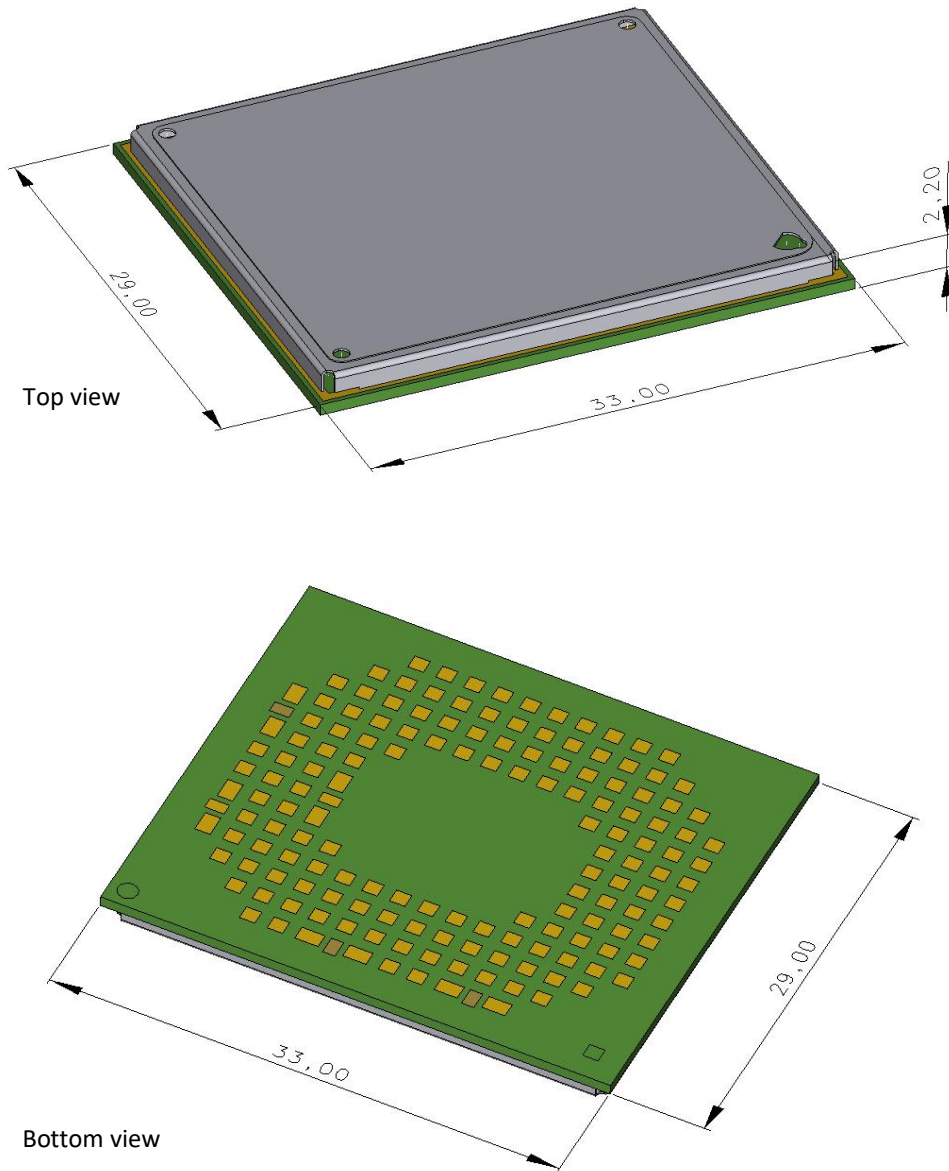

¹ The coloring of the 3D view does not reflect the module's real color.

6.2. Mounting ALS6A-E onto the Application Platform

This section describes how to mount ALS6A-E onto the PCBs, including land pattern and stencil design, board-level characterization, soldering conditions, durability and mechanical handling. For more information on issues related to SMT module integration see also [3].

Note: Kontron strongly recommends to solder all connecting pads for mechanical stability and heat dissipation. Not only must all supply pads and signals be connected appropriately, but all pads denoted as “Do not use” should also be soldered (but not electrically connected). Note also that in order to avoid short circuits between signal tracks on an external application's PCB and various markings at the bottom side of the module, it is recommended not to route the signal tracks on the top layer of an external PCB directly under the module, or at least to ensure that signal track routes are sufficiently covered with solder resist.

6.2.1. SMT PCB Assembly

6.2.1.1. Land Pattern and Stencil

The land pattern and stencil design as shown below is based on Kontron characterizations for lead-free solder paste on a four-layer test PCB and a 110 as well as a 150 micron-thick stencil.

The land pattern given in Figure 29 reflects the module's pad layout, including signal pads and ground pads (for pad assignment see Section 5.5.). Besides these pads there are ground areas on the module's bottom side that must not be soldered, e.g., the position marker. To prevent short circuits, it has to be ensured that there are no wires on the external application side that may connect to these module ground areas.

Figure 29: Land pattern (top layer)

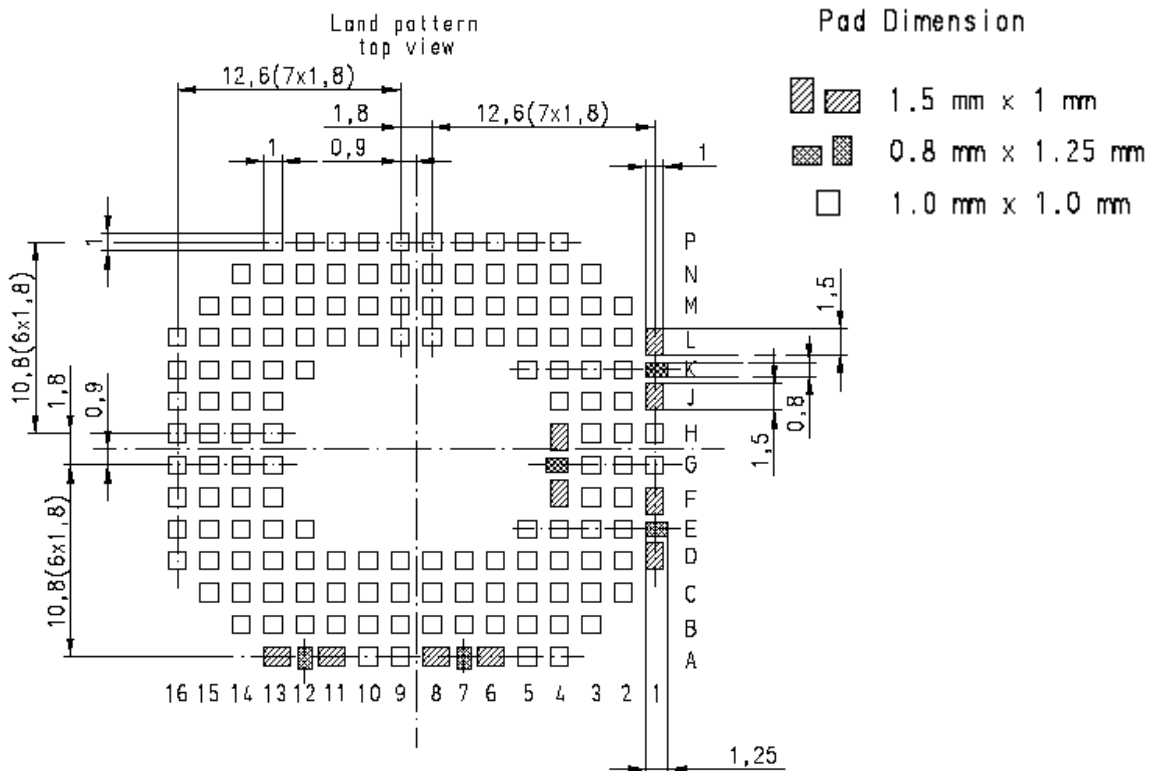

The stencil design illustrated in Figure 30 and Figure 31 is recommended by Kontron as a result of extensive tests with Kontron Daisy Chain modules.

Figure 30: Recommended design for 110 micron thick stencil (top layer)

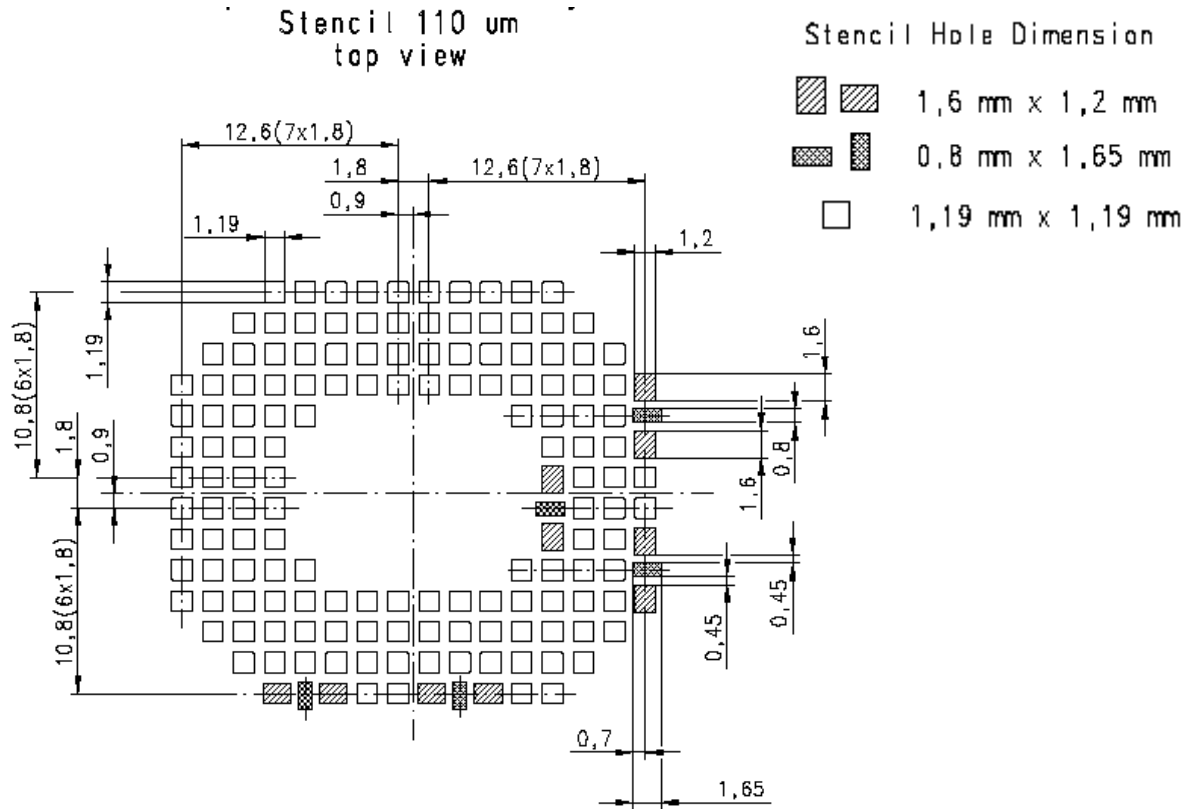
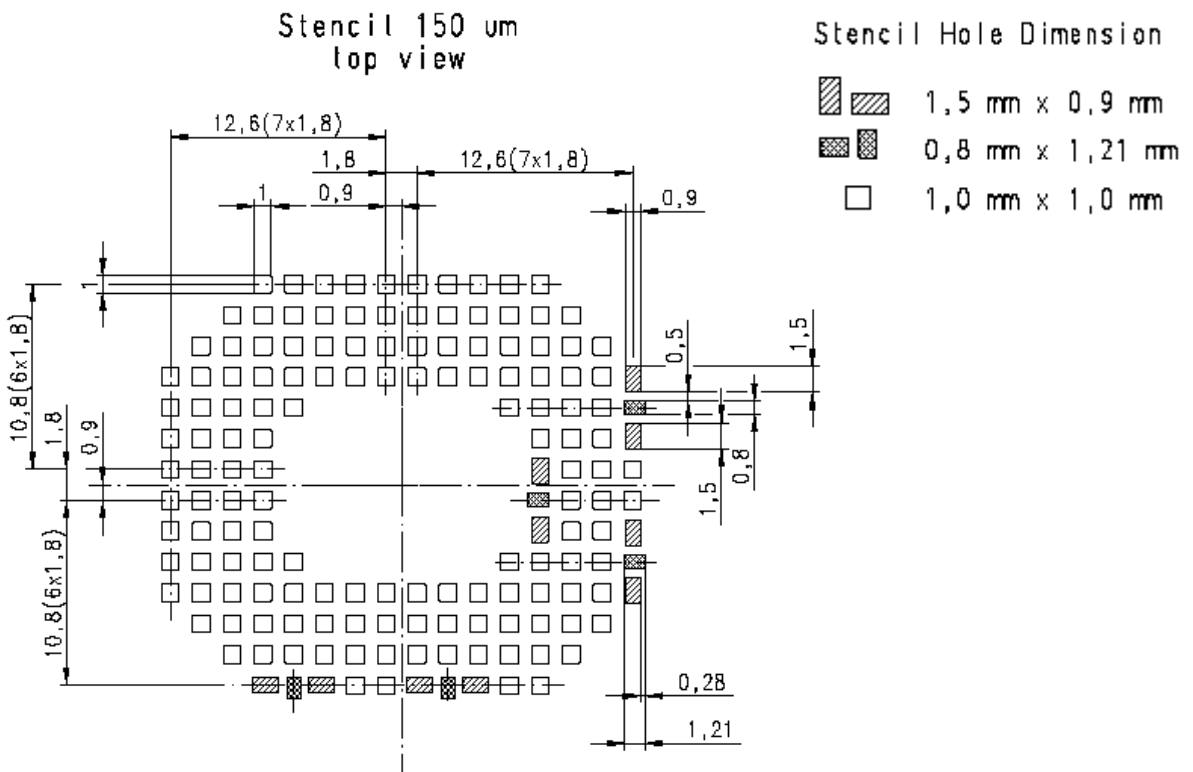

Figure 31: Recommended design for 150 micron thick stencil (top layer)



6.2.1.2. Board Level Characterization

Board level characterization issues should also be taken into account if devising an SMT process.

Characterization tests should attempt to optimize the SMT process with regard to board level reliability. This can be done by performing the following physical tests on sample boards: Peel test, bend test, tensile pull test, drop shock test and temperature cycling. Sample surface mount checks are described in [3].

It is recommended to characterize land patterns before an actual PCB production, taking individual processes, materials, equipment, stencil design, and reflow profile into account. For land and stencil pattern design recommendations see also Section 6.2.1.1.. Optimizing the solder stencil pattern design and print process is necessary to ensure print uniformity, to decrease solder voids, and to increase board level reliability.

Daisy chain modules for SMT characterization are available on request. For details refer to [3].

Generally, solder paste manufacturer recommendations for screen printing process parameters and reflow profile conditions should be followed. Maximum ratings are described in Section 6.2.3..

6.2.2. Moisture Sensitivity Level

ALS6A-E comprises components that are susceptible to damage induced by absorbed moisture.

Kontron's ALS6A-E module complies with the latest revision of the IPC/JEDEC J-STD-020 Standard for moisture sensitive surface mount devices and is classified as MSL 4.

For additional moisture sensitivity level (MSL) related information see Section 6.2.4. and Section 6.3.2..

6.2.3. Soldering Conditions and Temperature

6.2.3.1. Reflow Profile

Figure 32: Reflow Profile

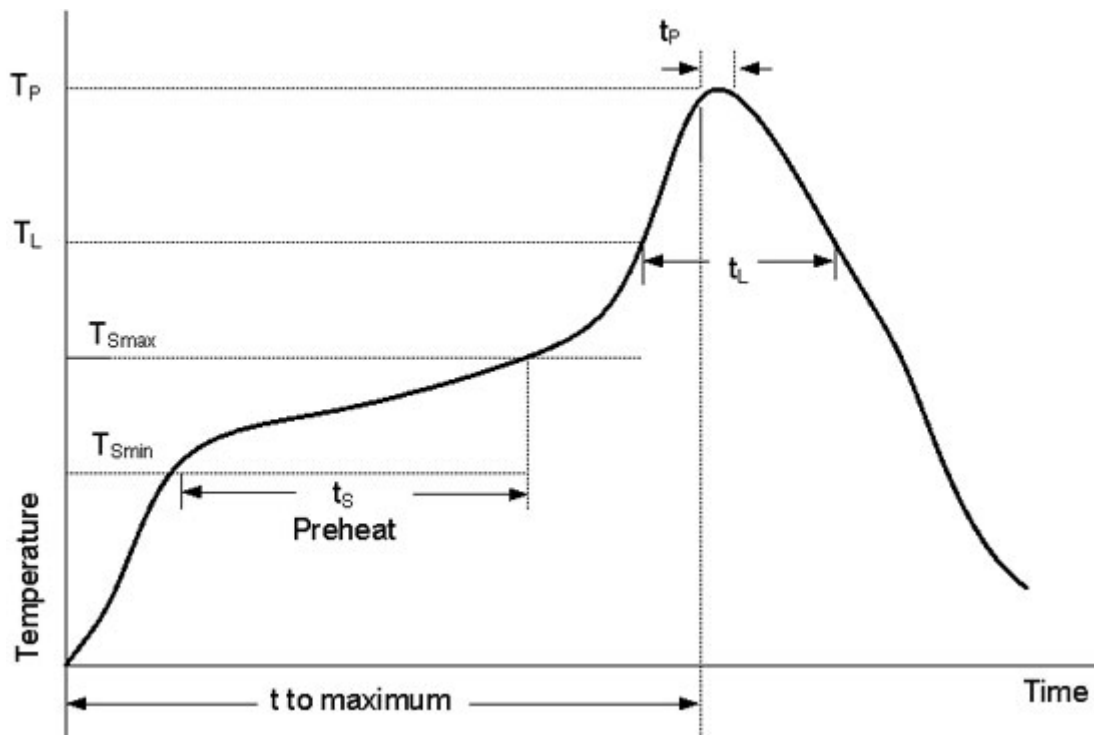

Table 26: Reflow temperature ratings¹

Profile Feature	Pb-Free Assembly
Preheat & Soak Temperature Minimum (T_{Smin}) Temperature Maximum (T_{Smax}) Time (t_{Smin} to t_{Smax}) (t_S)	150°C 200°C 60-120 seconds
Average ramp up rate (T_{Smax} to T_p)	3K/second max.
Liquidous temperature (T_L) Time at liquidous (t_L)	217°C 60-90 seconds
Peak package body temperature (T_p)	245°C +0/-5°C
Time (t_p) within 5 °C of the peak package body temperature (T_p)	30 seconds max.
Average ramp-down rate (T_p to T_{Smax})	3 K/second max.
Time 25°C to maximum temperature	8 minutes max.

¹ Please note that the reflow profile features and ratings listed above are based on the joint industry standard IPC/JEDEC J-STD-020D.1, and are as such meant as a general guideline. For more information on reflow profiles and their optimization please refer to [3].

6.2.3.2. Maximum Temperature and Duration

The following limits are recommended for the SMT board-level soldering process to attach the module:

- › A maximum module temperature of 245°C. This specifies the temperature as measured at the module's top side.
- › A maximum duration of 30 seconds at this temperature.

Please note that while the solder paste manufacturers' recommendations for best temperature and duration for solder reflow should generally be followed, the limits listed above must not be exceeded.

ALS6A-E is specified for one soldering cycle only. Once ALS6A-E is removed from the application, the module will very likely be destroyed and cannot be soldered onto another application.

6.2.4. Durability and Mechanical Handling

6.2.4.1. Storage Life

ALS6A-E modules, as delivered in tape and reel carriers, must be stored in sealed, moisture barrier anti-static bags. The shelf life in a sealed moisture bag is an estimated 12 months. However, such a life span requires a non-condensing atmospheric environment, ambient temperatures below 40°C and a relative humidity below 90%. Additional storage conditions are listed in [Table 21](#).

6.2.4.2. Processing Life

ALS6A-E must be soldered to an application within 72 hours after opening the moisture barrier bag (MBB) it was stored in.

As specified in the IPC/JEDEC J-STD-033 Standard, the manufacturing site processing the modules should have ambient temperatures below 30°C and a relative humidity below 60%.

6.2.4.3. Baking

Baking conditions are specified on the moisture sensitivity label attached to each MBB (see [Figure 37](#) for details):

- › It is *not necessary* to bake ALS6A-E, if the conditions specified in [Section 6.2.4.1.](#) and [Section 6.2.4.2.](#) were not exceeded.
- › It is *necessary* to bake ALS6A-E, if any condition specified in [Section 6.2.4.1.](#) and [Section 6.2.4.2.](#) was exceeded.

If baking is necessary, the modules must be put into trays that can be baked to at least 125°C. Devices should not be baked in tape and reel carriers at any temperature.

6.2.4.4. Electrostatic Discharge

Electrostatic discharge (ESD) may lead to irreversible damage for the module. It is therefore advisable to develop measures and methods to counter ESD and to use these to control the electrostatic environment at manufacturing sites.

Please refer to [Section 5.8.](#) for further information on electrostatic discharge.

6.3. Packaging

6.3.1. Tape and Reel

The single-feed tape carrier for ALS6A-E is illustrated in Figure 33. The figure also shows the proper part orientation. The tape width is 44mm and the ALS6A-E modules are placed on the tape with a 40mm pitch. The reels are 330mm in diameter with 100mm hubs. Each reel contains 500 modules.

6.3.1.1. Orientation

Figure 33: Carrier tape

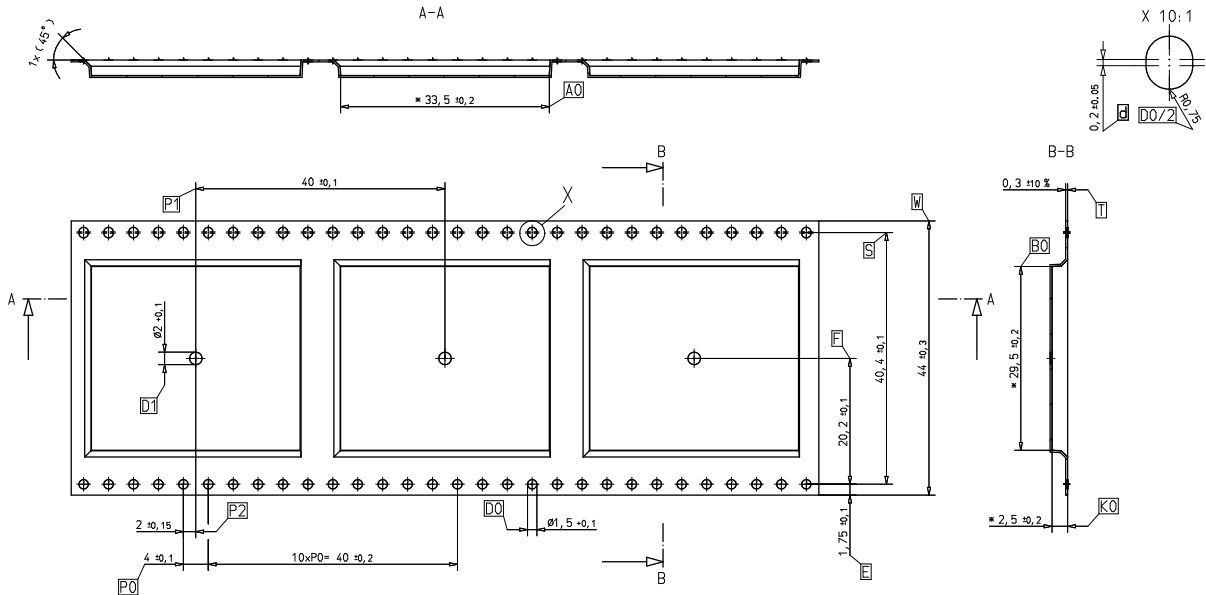
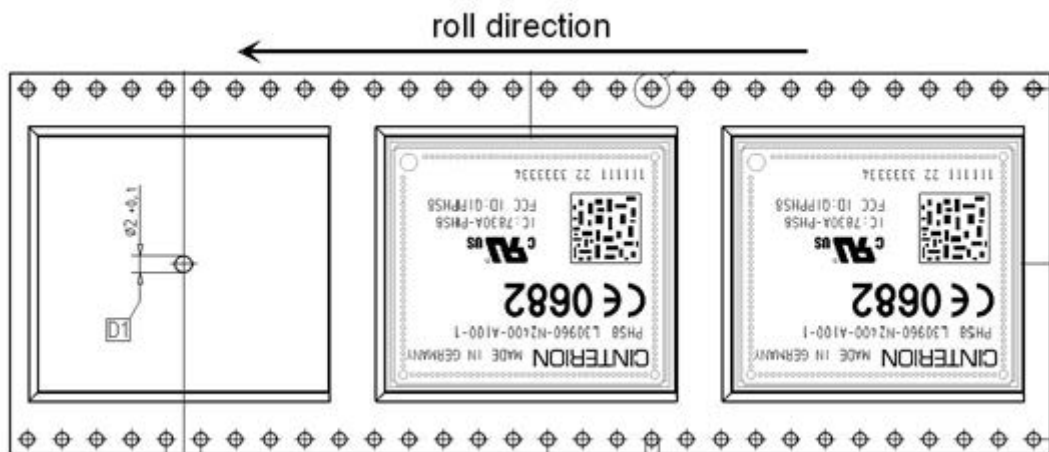

Figure 34: Roll direction



6.3.1.2. Barcode Label

A barcode label provides detailed information on the tape and its contents. It is attached to the reel.

Figure 35: Barcode label on tape reel

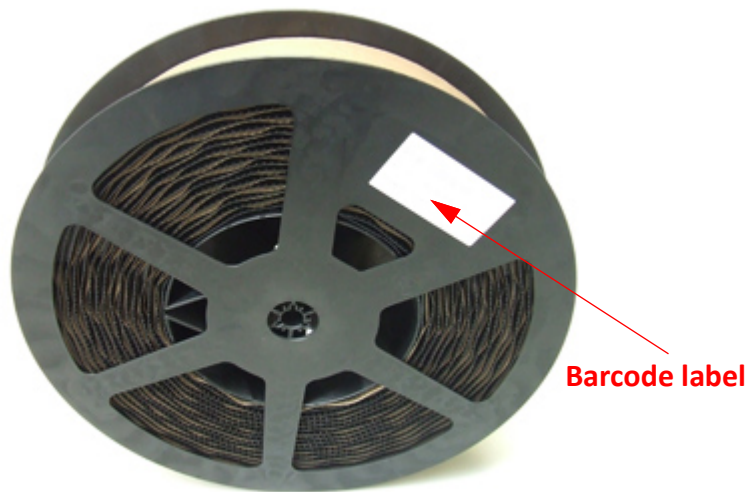

6.3.2. Shipping Materials

ALS6A-E is distributed in tape and reel carriers. The tape and reel carriers used to distribute ALS6A-E are packed as described below, including the following required shipping materials:

- › Moisture barrier bag, including desiccant and humidity indicator card
- › Transportation bag

6.3.2.1. Moisture Barrier Bag

The tape reels are stored inside a moisture barrier bag (MBB), together with a humidity indicator card and desiccant pouches - see [Figure 36](#). The bag is ESD protected and delimits moisture transmission. It is vacuum-sealed and should be handled carefully to avoid puncturing or tearing. The bag protects the ALS6A-E modules from moisture exposure. It should not be opened until the devices are ready to be soldered onto the application.

Figure 36: Moisture barrier bag (MBB) with imprint

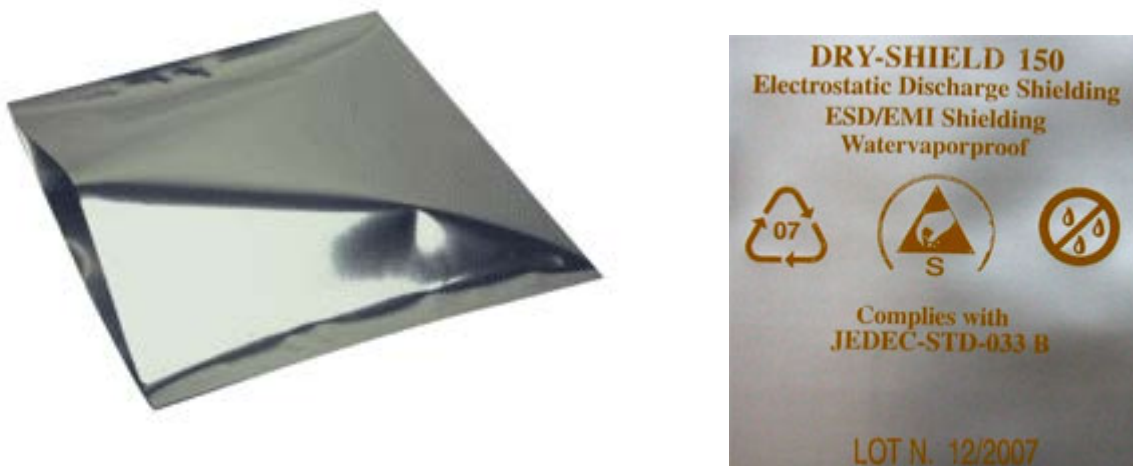

The label shown in Figure 37 summarizes requirements regarding moisture sensitivity, including shelf life and baking requirements. It is attached to the outside of the moisture barrier bag.

Figure 37: Moisture Sensitivity Label



CAUTION

This bag contains

MOISTURE-SENSITIVE DEVICES

LEVEL

4

1. Calculated shelf life in sealed bag:
12 months at < 40 °C and < 90% relative humidity (RH)
2. Peak package body temperature: 245 °C
3. After bag is opened, devices that will be subject to reflow solder or other high temperature process must be
 - a) mounted within: 72 hours of factory conditions < 30 °C / 60% RH
 - b) stored at < 10% RH
4. Devices require bake, before mounting, if
 - a) Humidity Indicator Card is > 10% when read at 23 +/- 5 °C
 - b) 3a or 3b not met
5. If baking is required, refer to IPC/Jedec J-STD-033 for bake procedure

Note: The devices are shipped in a non heat-resistant carrier and may not be baked in the carriers
6. The maximum guaranteed soldering cycle of the module is limited to 1 cycle

Bag Seal Date: DD.MM.YYYY

Note: MSL level and body temperature defined by IPC/JEDEC J-STD-020

CINTERION

INFO-2DELIVERYPARTNUMBER

Peak package body temperature: 245°C

Qty. : 000

Bag Seal Date (DDMMYYYY) : DDMMYYYY



Package ID: WM8000123412



MBBs contain one or more desiccant pouches to absorb moisture that may be in the bag. The humidity indicator card described below should be used to determine whether the enclosed components have absorbed an excessive amount of moisture.

The desiccant pouches should not be baked or reused once removed from the MBB.

The humidity indicator card is a moisture indicator and is included in the MBB to show the approximate relative humidity level within the bag. A sample humidity card is shown in Figure 38. If the components have been exposed to moisture above the recommended limits, the units will have to be rebaked.

Figure 38: Humidity Indicator Card - HIC

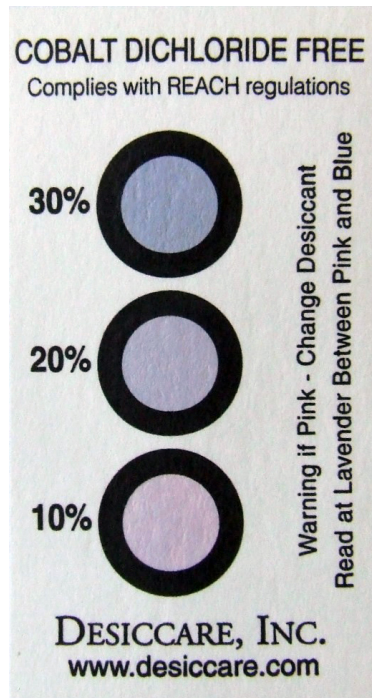

A baking is required if the humidity indicator inside the bag indicates 10% RH or more.

6.3.2.2. Transportation Box

Tape and reel carriers are distributed in a box, marked with a barcode label for identification purposes. A box contains 2 reels with 500 modules each.

7/ Sample Application

Figure 39 shows a typical example of how to integrate an ALS6A-E module with an application.

The PWR_IND line is an open collector that needs an external pull-up resistor which connects to the voltage supply VCC μ C of the microcontroller. Low state of the open collector pulls the PWR_IND signal low and indicates that the ALS6A-E module is active, high level notifies the Power Down mode.

If the module is in Power Down mode avoid current flowing from any other source into the module circuit, for example reverse current from high state external control lines. Therefore, the controlling application must be designed to prevent reverse flow.

While developing SMT applications it is strongly recommended to provide test points for certain signals, i.e., lines to and from the module - for debug and/or test purposes. The SMT application should allow for an easy access to these signals. For details on how to implement test points see [3].

The EMC measures are best practice recommendations. In fact, an adequate EMC strategy for an individual application is very much determined by the overall layout and, especially, the position of components.

Some LGA pads are connected to clocks or high speed data streams that might interfere with the module's antenna. The RF receiver would then be blocked at certain frequencies (self interference). The external application's PCB tracks connected to these pads should therefore be well shielded or kept away from the antenna. This applies especially to the USB and UICC/SIM interfaces.

The analog-to-digital converter (ADCx_IN lines) can be used for antenna diagnosis. A sample antenna detection circuit can be found in Figure 40 and Figure 41.

Disclaimer:

No warranty, either stated or implied, is provided on the sample schematic diagram shown in Figure 39 and the information detailed in this section. As functionality and compliance with national regulations depend to a great amount on the used electronic components and the individual application layout manufacturers are required to ensure adequate design and operating safeguards for their products using ALS6A-E modules.

Figure 39: ALS6A-E sample application

ALS6A

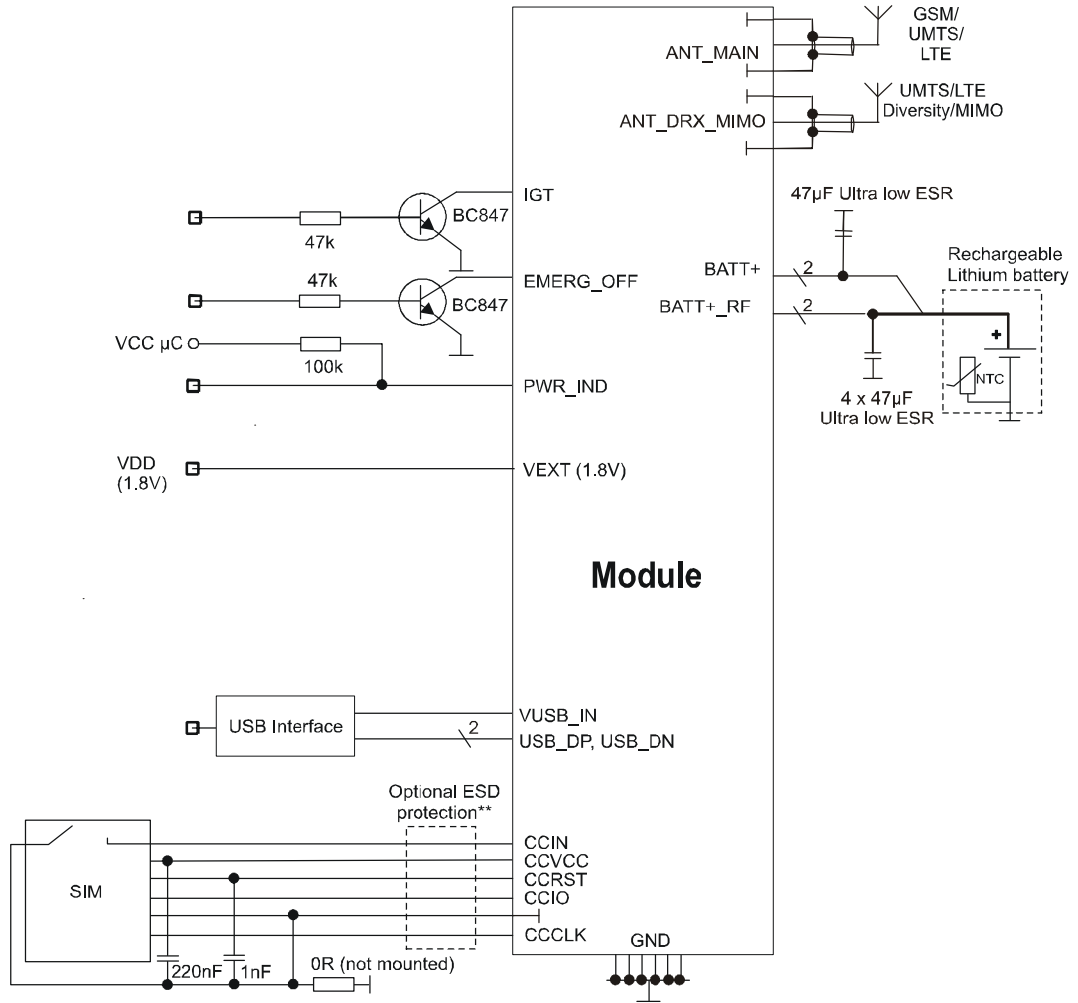

All SIM components shall be close to card holder.
Keep SIM wires low capacitive.

** See Section 3.6.1. for details on enhanced ESD protection

7.1. Sample Circuit for Antenna Detection

The following figures explain how an RF antenna detection circuit may be implemented for ALS6A-E to be able to detect 1 or 2 antennas (for basic circuit and diagnostic principles - including usage of GPIO and ADCx_IN pads - please refer to Section 4.1.3.). Figure 40 gives a general overview, Figure 41 depicts the actual antenna detection layout and shows how ESD protection, i.e., an RF/DC bridge will have to be handled. The switch driver and antenna switch mentioned in Figure 40 will have to be realized by the application manufacturer.

Properties for the components mentioned in Figure 40 and Figure 41 are given in Table 27 - parts list.

Figure 40: Antenna diagnosis - overview

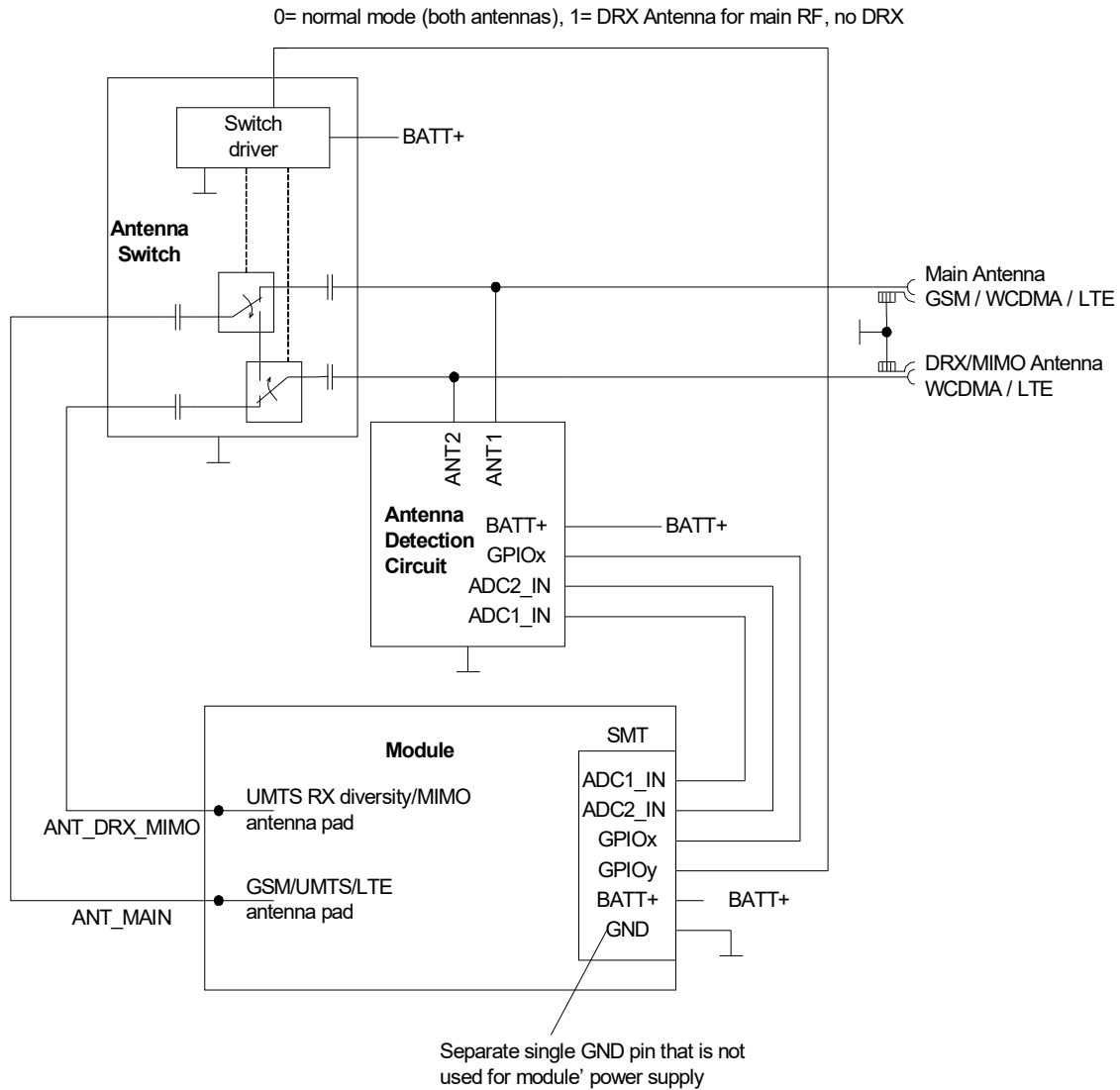

Figure 41: Antenna diagnosis - antenna detection schematic

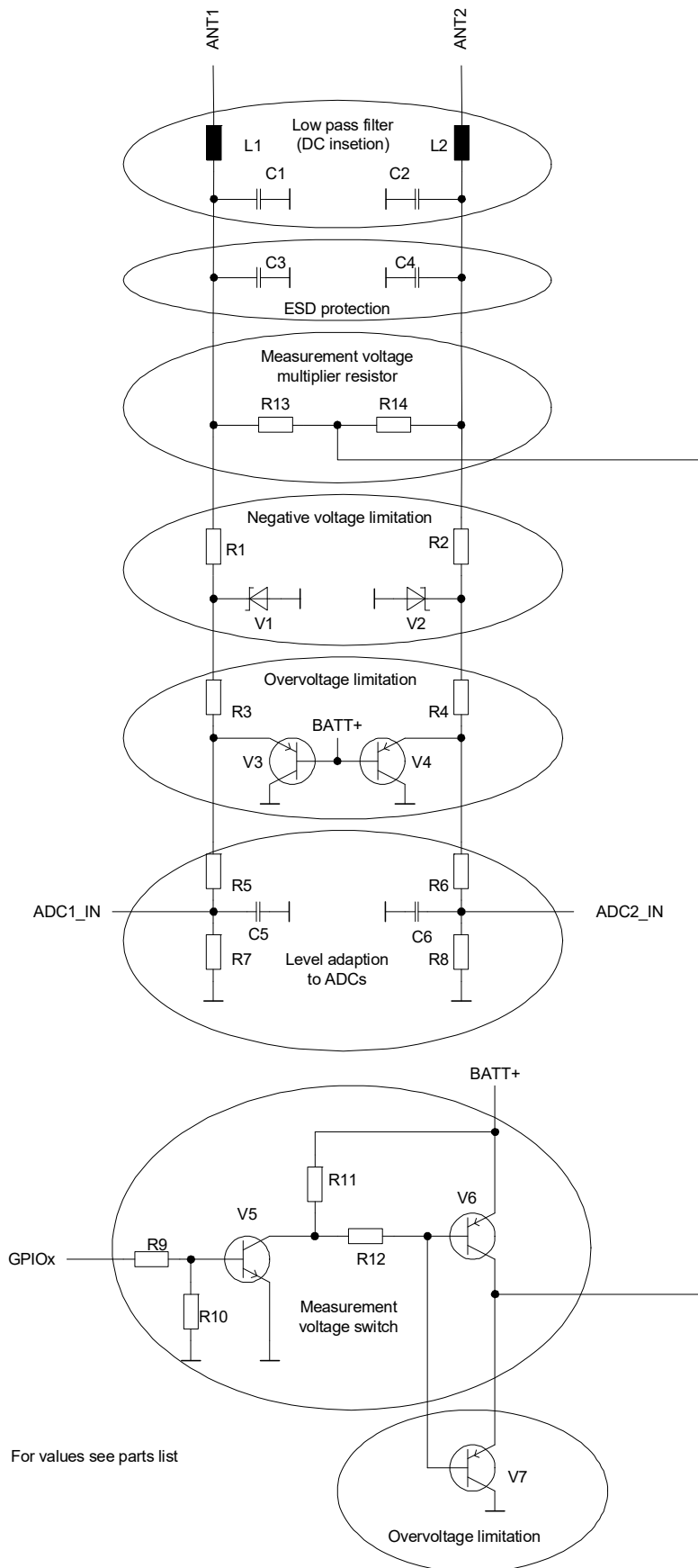

Table 27: Antenna diagnosis reference circuit - parts list

Reference	Part	Value	Tolerance	Conditions	Size
R1,2	Resistor	22R			
R3,4	Resistor	10k		$\geq 125\text{mW}$	
R5,6	Resistor	140k	1%		
R7,8	Resistor	100k	1%		
R9,10	Resistor	100k			
R11,12	Resistor	10k		$\geq 125\text{mW}$	
R13,14	Resistor	4k4 (e.g., 2x2k2 or 4x1k1)	1%	$\geq 300\text{mW}$	
C1,2	Capacitor	22p		50V	≤ 0402
C3,4	Capacitor	100n		50V	
C5,6	Capacitor	100n		10V	
V1,2	Schottky diode	RB520-40		40V	
V3,4,6,7	Transistor	BC857			
V5	Transistor	BC847			
L1,2	Inductor	39nH		Wire wound High Q	0402

8/ Reference Approval

8.1. Reference Equipment for Type Approval

The Kontron reference setup submitted to type approve ALS6A-E is shown in Figure 42. The module (i.e., the evaluation module) is connected to the DSB75 by means of a flex cable and a special DSB75 adapter. The GSM/UMTS/LTE test equipment is connected via edge mount SMA connectors soldered to the module's antenna pads.

For ESD tests and evaluation purposes, it is also possible connect the module to the GSM/UMTS/LTE test equipment through an SMA-to-Hirose-U.FL antenna cable and the SMA antenna connectors of the DSB75 adapter.

A further option is to mount the evaluation module directly onto the DSB75 adapter's 80-pin board-to-board connector and to connect the test equipment as shown below.

Figure 42: Reference equipment for type approval

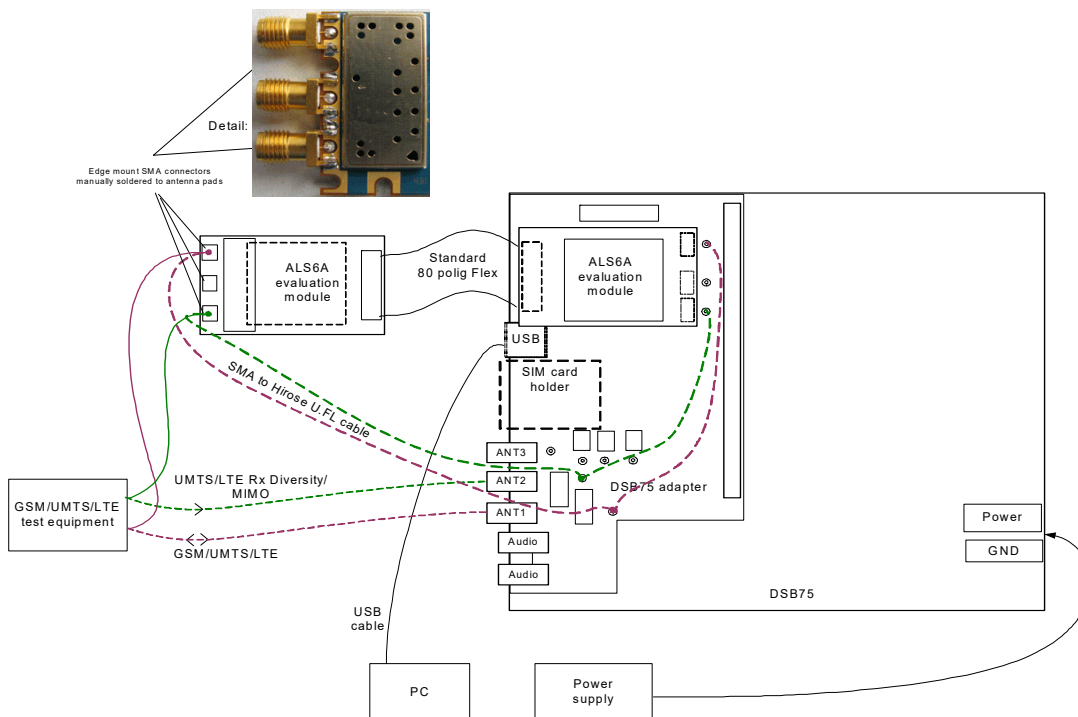

8.2. Compliance with FCC Rules and Regulations

The Equipment Authorization Certification for the Kontron modules reference application described in [Section 8.1](#). will be registered under the following identifiers:

- › ALS6A-E:
FCC Identifier: 2AATHALS6A-E
Granted to Kontron Europe GmbH

Manufacturers of mobile or fixed devices incorporating ALS6A-E modules are authorized to use the FCC Grants of the ALS6A-E modules for their own final products according to the conditions referenced in these documents. In this case, the FCC label of the module shall be visible from the outside, or the host device shall bear a second label stating "Contains FCC ID: 2AATHALS6A-E". The integration is limited to fixed or mobile categorised host devices, where a separation distance between the antenna and any person of min. 20cm can be assured during normal operating conditions. For mobile and fixed operation configurations the antenna gain, including cable loss, must not exceed the limits 9.51 dBi (2600MHz).

IMPORTANT:

Manufacturers of portable applications incorporating ALS6A-E modules are required to have their final product certified and apply for their own FCC Grant related to the specific portable mobile. This is mandatory to meet the SAR requirements for portable mobiles (see [Section 1.4.2](#). for detail).

Changes or modifications not expressly approved by the party responsible for compliance could void the user's authority to operate the equipment.

Note: This equipment has been tested and found to comply with the limits for a Class B digital device, pursuant to part 15 of the FCC Rules. These limits are designed to provide reasonable protection against harmful interference in a residential installation. This equipment generates, uses and can radiate radio frequency energy and, if not installed and used in accordance with the instructions, may cause harmful interference to radio communications. However, there is no guarantee that interference will not occur in a particular installation. If this equipment does cause harmful interference to radio or television reception, which can be determined by turning the equipment off and on, the user is encouraged to try to correct the interference by one or more of the following measures:

- › Reorient or relocate the receiving antenna.
- › Increase the separation between the equipment and receiver.
- › Connect the equipment into an outlet on a circuit different from that to which the receiver is connected.
- › Consult the dealer or an experienced radio/TV technician for help.

9/ Appendix

9.1. List of Parts and Accessories

Table 28: List of parts and accessories

Description	Supplier	Ordering information
ALS6A-E	Kontron	Standard module Kontron IMEI: Packaging unit (ordering) number: L30960-N3160-B100 Module label number: S30960-S3160-B100-1
DSB75 Support Box	Kontron	Ordering number: L36880-N8811-A100
DSB75 adapter for mounting the evaluation module	Kontron	Ordering number: L30960-N2301-A100
Votronic handset for approval purposes	Votronic / Kontron	Kontron ordering number: L36880-N8301-A107 Votronic ordering number: HH-SI-30.3/V1.1/0 Votronic Entwicklungs- und Produktionsgesellschaft für elektronische Geräte mbH Saarbrücker Str. 8 66386 St. Ingbert Germany Phone: +49-(0)6 89 4 / 92 55-0 Fax: +49-(0)6 89 4 / 92 55-88 Email: contact@votronic.com
SIM card holder incl. push button ejector and slide-in tray	Molex	Ordering numbers: 91228 91236 Sales contacts are listed in Table 29 .
U.FL antenna connector	Hirose or Molex	Sales contacts are listed in Table 29 and Table 30 .

Table 29: Molex sales contacts (subject to change)

Molex For further information please click: http://www.molex.com	Molex Deutschland GmbH Otto-Hahn-Str. 1b 69190 Walldorf Germany Phone: +49-6227-3091-0 Fax: +49-6227-3091-8100 Email: mxgermany@molex.com	American Headquarters Lisle, Illinois 60532 U.S.A. Phone: +1-800-78MOLEX Fax: +1-630-969-1352
Molex China Distributors Beijing, Room 1311, Tower B, COFCO Plaza No. 8, Jian Guo Men Nei Street, 100005 Beijing P.R. China Phone: +86-10-6526-9628 Fax: +86-10-6526-9730	Molex Singapore Pte. Ltd. 110, International Road Jurong Town, Singapore 629174 Phone: +65-6-268-6868 Fax: +65-6-265-6044	Molex Japan Co. Ltd. 1-5-4 Fukami-Higashi, Yamato-City, Kanagawa, 242-8585 Japan Phone: +81-46-265-2325 Fax: +81-46-265-2365

Table 30: Hirose sales contacts (subject to change)

Hirose Ltd. For further information please click: http://www.hirose.com	Hirose Electric (U.S.A.) Inc 2688 Westhills Court Simi Valley, CA 93065 U.S.A. Phone: +1-805-522-7958 Fax: +1-805-522-3217	Hirose Electric Europe B.V. German Branch: Herzog-Carl-Strasse 4 73760 Ostfildern Germany Phone: +49-711-456002-1 Fax: +49-711-456002-299 Email: info@hirose.de
Hirose Electric Europe B.V. UK Branch: First Floor, St. Andrews House, Caldecotte Lake Business Park, Milton Keynes MK7 8LE Great Britain Phone: +44-1908-369060 Fax: +44-1908-369078	Hirose Electric Co., Ltd. 5-23, Osaki 5 Chome, Shinagawa-Ku Tokyo 141 Japan Phone: +81-03-3491-9741 Fax: +81-03-3493-2933	Hirose Electric Europe B.V. Hogehill- weg 8 1101 CC Amsterdam Z-O Netherlands Phone: +31-20-6557-460 Fax: +31-20-6557-469

9.2. Mounting Advice Sheet

To prevent mechanical damage, be careful not to force, bend or twist the module. Be sure it is soldered flat against the host device (see also [Section 6.2.](#)). The advice sheet on the next page shows a number of examples for the kind of bending that may lead to mechanical damage of the module (the module as part of an external application is integrated into a housing).

.

Mounting Advice

Do **NOT BEND** the Module

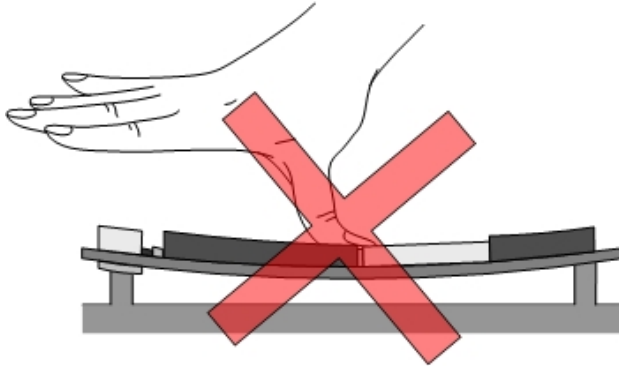

- By pressing from above

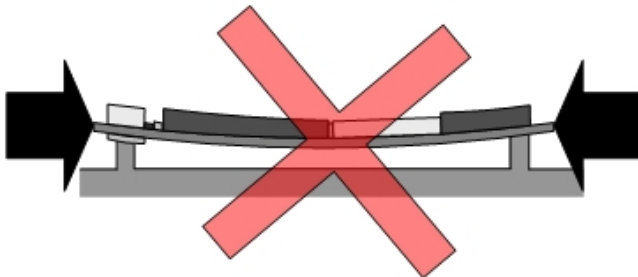

- By mounting under pressure

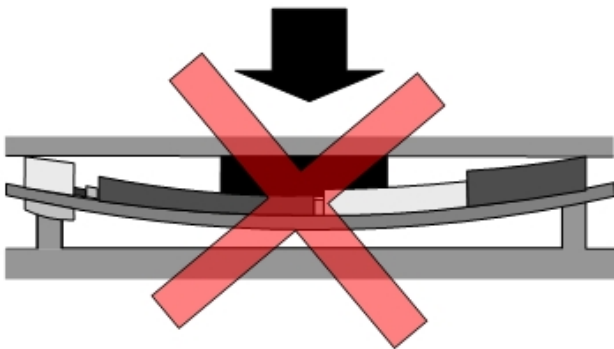

- By putting objects on top

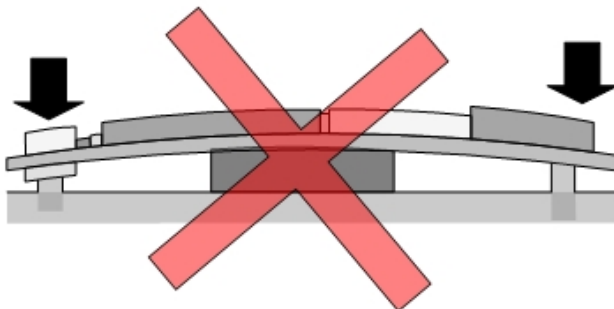

- By putting objects below



About Kontron

Kontron is a global leader in IoT/Embedded Computing Technology (ECT) and offers individual solutions in the areas of Internet of Things (IoT) and Industry 4.0 through a combined portfolio of hardware, software and services. With its standard and customized products based on highly reliable state-of-the-art technologies, Kontron provides secure and innovative applications for a wide variety of industries. As a result, customers benefit from accelerated time-to-market, lower total cost of ownership, extended product lifecycles and the best fully integrated applications.

For more information, please visit: www.kontron.com

Global Headquarters

Kontron Europe GmbH

Gutenbergstraße 2
D-85737 Ismaning, Germany
Phone: +49 8214 4086-0
Mail: info@kontron.com

www.kontron.de



kontron