



ALS3-US R4

Hardware Interface Description

Version: 04.003d

DocId: ALS3-USR4_HD_v04.003d

Status: Confidential / Released

Date: 2024-05-21

DISCLAIMER

Kontron would like to point out that the information contained in this document may be subject to alteration, particularly as a result of the constant upgrading of Kontron products. This document does not entail any guarantee on the part of Kontron with respect to technical processes described in the document or any product characteristics set out in the document. Kontron assumes no responsibility or liability for the use of the described product(s), conveys no license or title under any patent, copyright or mask work rights to these products and makes no representations or warranties that these products are free from patent, copyright or mask work right infringement unless otherwise specified. Applications that are described in this document are for illustration purposes only. Kontron makes no representation or warranty that such application will be suitable for the specified use without further testing or modification. Kontron expressly informs the user that this document only contains a general description of processes and instructions which may not be applicable in every individual case. In cases of doubt, please contact Kontron.

This document is protected by copyright. All rights are reserved by Kontron. No part of this document may be reproduced, transmitted, transcribed, stored in a retrieval system, or translated into any language or computer language, in any form or by any means (electronic, mechanical, photocopying, recording, or otherwise), without the express written permission of Kontron. Kontron points out that the information contained in this document is constantly being updated in line with the technical alterations and improvements made by Kontron to the products and thus this document only reflects the technical status of the products by Kontron at the time of publishing.

Brand and product names are trademarks or registered trademarks of their respective owners.

© 2024 by Kontron Europe GmbH

Kontron Europe GmbH
Gutenbergstraße 2
85737 Ismaning
Germany
www.kontron.com

Contents

Document History	8
1/ Introduction	12
1.1. Supported Products	12
1.2. Related Documents	12
1.3. Terms and Abbreviations	12
1.4. Regulatory and Type Approval Information	15
1.4.1. Directives and Standards	15
1.4.2. SAR requirements specific to portable mobiles	18
1.4.3. SELV Requirements	19
1.4.4. Safety Precautions	19
2/ Product Concept	20
2.1. Key Features at a Glance	20
2.2. ALS3-US R4 System Overview	23
2.3. Circuit Concept	24
3/ Application Interface	25
3.1. Operating Modes	26
3.2. Power Supply	27
3.2.1. Minimizing Power Losses	28
3.2.2. Monitoring Power Supply by AT Command	28
3.3. Power-Up / Power-Down Scenarios	29
3.3.1. Turn on ALS3-US R4	29
3.3.2. Signal States after Startup	30
3.3.3. Turn off ALS3-US R4 Using AT Command	31
3.3.4. Turn off ALS3-US R4 Using IGT Line	32
3.3.5. Automatic Shutdown	32
3.3.5.1. Thermal Shutdown	33
3.3.5.2. Deferred Shutdown at Extreme Temperature Conditions	33
3.3.5.3. Undervoltage Shutdown	34
3.3.5.4. Overvoltage Shutdown	34
3.3.6. Turn off ALS3-US R4 in Case of Emergency	35
3.4. Power Saving	36
3.4.1. Power Saving while Attached to GSM Networks	36
3.4.2. Power Saving while Attached to WCDMA Networks	37
3.4.3. Power Saving while Attached to LTE Networks	37
3.4.4. Wake-up via RTS0	38
3.5. RTC Backup	39
3.6. USB Interface	40
3.6.1. Reducing Power Consumption	41
3.7. Serial Interface ASC0	42
3.8. UICC/SIM/USIM Interface	43
3.8.1. Enhanced ESD Protection for SIM Interface	45
3.9. Analog Audio Interface	46
3.9.1. Microphone Inputs and Supply	47
3.9.2. Loudspeaker Output	49
3.10. Digital Audio Interface	50
3.10.1. Pulse Code Modulation Interface (PCM)	50
3.10.2. Inter IC Sound Interface (I ² S)	52
3.11. Analog-to-Digital Converter (ADC)	53
3.12. GPIO Interface	53
3.13. Control Signals	54
3.13.1. PWR_IND Signal	54
3.13.2. Behavior of the RING0 Line	54
3.13.3. Remote Wakeup	55
3.13.4. Low Current Indicator	56
3.13.5. Network Connectivity and Technology Status Signals	57
3.13.6. 700MHz Antenna Switch Control	57
4/ GNSS Receiver	58
5/ Antenna Interfaces	59
5.1. GSM/UMTS/LTE Antenna Interface	59
5.1.1. Antenna Installation	60
5.1.2. RF Line Routing Design	61
5.1.2.1. Line Arrangement Examples	61
5.1.2.2. Routing Example	63

	5.1.3. ESD Protection for Antenna Interfaces	64
	5.1.4. RF Antenna Diagnostic	65
	5.2. GNSS Antenna Interface.....	68
	5.2.1. GNSS Antenna Diagnostic	69
6/	Electrical, Reliability and Radio Characteristics	71
	6.1. Absolute Maximum Ratings	71
	6.2. Operating Temperatures.....	72
	6.3. Storage Conditions	72
	6.4. Reliability Characteristics.....	73
	6.4.1. Bending Tests.....	74
	6.5. Pad Assignment and Signal Description	75
	6.6. Power Supply Ratings.....	83
	6.7. Electrical Characteristics of the Voiceband Part	86
	6.7.1. Setting Audio Parameters by AT Commands	86
	6.7.2. Audio Programming Model.....	86
	6.7.3. Characteristics of Audio Modes	87
	6.7.4. Voiceband Receive Path.....	88
	6.7.5. Voiceband Transmit Path.....	88
	6.8. RF Antenna Interface Characteristics.....	89
	6.9. GNSS Interface Characteristics.....	93
	6.10. Electrostatic Discharge.....	94
7/	Mechanics, Mounting and Packaging	95
	7.1. Mechanical Dimensions of ALS3-US R4.....	95
	7.2. Mounting ALS3-US R4 onto the Application Platform	97
	7.2.1. SMT PCB Assembly.....	97
	7.2.1.1. Land Pattern and Stencil	97
	7.2.1.2. Board Level Characterization	99
	7.2.2. Moisture Sensitivity Level	99
	7.2.3. Soldering Conditions and Temperature.....	99
	7.2.3.1. Reflow Profile	99
	7.2.3.2. Maximum Temperature and Duration	100
	7.2.4. Durability and Mechanical Handling.....	101
	7.2.4.1. Storage Life	101
	7.2.4.2. Processing Life.....	101
	7.2.4.3. Baking.....	101
	7.2.4.4. Electrostatic Discharge	101
	7.3. Packaging	102
	7.3.1. Tape and Reel	102
	7.3.1.1. Orientation.....	102
	7.3.1.2. Barcode Label.....	103
	7.3.2. Shipping Materials	103
	7.3.2.1. Moisture Barrier Bag.....	103
	7.3.2.2. Transportation Box.....	105
8/	Sample Application	106
	8.1. Sample Level Conversion Circuit	108
	8.2. Sample Circuit for Antenna Detection	109
9/	Reference Approval	112
	9.1. Reference Equipment for Type Approval.....	112
	9.2. Compliance with FCC and ISED Rules and Regulations	113
10/	Appendix	115
	10.1. List of Parts and Accessories	115
	10.2. Mounting Advice Sheet	117

Tables

Table 1: Directives.....	15
Table 2: Standards of North American type approval.....	15
Table 3: Standards of European type approval.....	15
Table 4: Requirements of quality.....	16
Table 5: Standards of the Ministry of Information Industry of the People’s Republic of China.....	17
Table 6: Toxic or hazardous substances or elements with defined concentration limits.....	17
Table 7: Overview of operating modes.....	26
Table 8: Signal states.....	30
Table 9: Temperature dependent behavior.....	33
Table 10: DCE-DTE wiring of ASCO.....	42
Table 11: Signals of the SIM interface (SMT application interface).....	43
Table 12: Input resistor values versus input gain.....	47
Table 13: Overview of PCM pin functions.....	50
Table 14: Overview of I ² S pin functions.....	52
Table 15: Host wakeup lines.....	55
Table 16: Low current indicator line.....	56
Table 17: Return loss in the active band.....	59
Table 18: Possible GPIOx and GPIOy signal states if used for antenna diagnosis.....	67
Table 19: Assured antenna diagnostic states.....	67
Table 20: GSM/UMTS/LTE antenna diagnostic decision threshold.....	67
Table 21: Values of the GNSS antenna diagnostic measurements and their meaning.....	69
Table 22: Absolute maximum ratings.....	71
Table 23: Board temperature.....	72
Table 24: Storage conditions.....	72
Table 25: Summary of reliability test conditions.....	73
Table 26: Overview: Pad assignments.....	75
Table 27: Signal description.....	78
Table 28: Voltage supply ratings.....	83
Table 29: Current consumption ratings.....	83
Table 30: Audio parameters adjustable by AT command.....	86
Table 31: Voiceband characteristics.....	87
Table 32: Voiceband receive path.....	88
Table 33: Voiceband transmit path.....	88
Table 34: RF Antenna interface GSM/UMTS/LTE (at operating temperature range).....	89
Table 35: GNSS properties.....	93
Table 36: Power supply for active GNSS antenna.....	93
Table 37: Electrostatic values.....	94
Table 38: Reflow temperature recommendations.....	100
Table 39: Antenna diagnosis reference circuit - parts list.....	111
Table 40: Antenna gain limits for FCC and ISED.....	113
Table 41: List of parts and accessories.....	115
Table 42: Molex sales contacts (subject to change).....	116
Table 43: Hirose sales contacts (subject to change).....	116

Figures

Figure 1: ALS3-US R4 system overview	23
Figure 2: ALS3-US R4 block diagram	24
Figure 3: Decoupling capacitor(s) for BATT+	27
Figure 4: Power supply limits during transmit burst	28
Figure 5: Power-on with IGT	29
Figure 6: Signal states during turn-off procedure	31
Figure 7: Timing of IGT if used as ON/OFF switch	32
Figure 8: Shutdown by EMERG_OFF signal	35
Figure 9: Power saving and paging in GSM networks	36
Figure 10: Power saving and paging in WCDMA networks	37
Figure 11: Power saving and paging in LTE networks	37
Figure 12: Wake-up via RTS0	38
Figure 13: RTC supply variants	39
Figure 14: USB circuit	40
Figure 15: Serial interface ASC0	42
Figure 16: First UICC/SIM/USIM interface	44
Figure 17: Second UICC/SIM/USIM interface	44
Figure 18: SIM interface - enhanced ESD protection	45
Figure 19: Structure of audio input and supply	47
Figure 20: Single ended microphone connection	48
Figure 21: Differential microphone connection	48
Figure 22: Line input	49
Figure 23: Differential loudspeaker connection	49
Figure 24: Line output connection	49
Figure 25: PCM timing short frame (master, 4096KHz, 16kHz sample rate)	51
Figure 26: PCM timing long frame (master, 128kHz, 8kHz sample rate)	51
Figure 27: I ² S timing (master mode)	52
Figure 28: PWR_IND signal	54
Figure 29: Low current indication timing (still to be confirmed)	56
Figure 30: LED circuit (example)	57
Figure 31: Antenna pads (bottom view)	60
Figure 32: Embedded Stripline line arrangement	61
Figure 33: Micro-Stripline line arrangement samples	62
Figure 34: Routing to application's RF connector	63
Figure 35: ALS3-US R4 evaluation board layer table	63
Figure 36: ESD protection for RF antenna interface	64
Figure 37: Resistor measurement used for antenna detection	65
Figure 38: Basic layout sample for antenna detection	66
Figure 39: Supply voltage for active GNSS antenna	68
Figure 40: ESD protection for passive GNSS antenna	69
Figure 41: Sample GNSS antenna detection circuit	70
Figure 42: Bending test setup	74
Figure 43: ALS3-US R4 bottom view: Pad assignments	76
Figure 44: ALS3-US R4 top view: Pad assignments	77
Figure 45: Audio programming model	86
Figure 46: ALS3-US R4 – top and bottom view	95
Figure 47: Dimensions of ALS3-US R4 (all dimensions in mm)	96
Figure 48: Land pattern (top layer)	97
Figure 49: Recommended design for 110 micron thick stencil (top layer)	98
Figure 50: Recommended design for 150 micron thick stencil (top layer)	98
Figure 51: Reflow Profile	99
Figure 52: Carrier tape	102
Figure 53: Roll direction	102
Figure 54: Barcode label on tape reel	103
Figure 55: Moisture barrier bag (MBB) with imprint	103
Figure 56: Moisture Sensitivity Label	104
Figure 57: Humidity Indicator Card - HIC	105
Figure 58: ALS3-US R4 sample application	107
Figure 59: Sample level conversion circuit	108

Figure 60: Antenna diagnosis - overview 109
Figure 61: Antenna diagnosis - antenna detection schematic 110
Figure 62: Reference equipment for type approval..... 112

Document History

Preceding document: "ALS3-US R4 Hardware Interface Description" v04.003c

New document: "ALS3-US R4 Hardware Interface Description" v04.003d

Chapter	What is new
--	Updated layout (because of company name change).
1.4.1.	Updated some standards versions.
9.2.	Revised FCC Identifier as well as ISED Certification Number.

Preceding document: "ALS3-US R4 Hardware Interface Description" v04.003b

New document: "ALS3-US R4 Hardware Interface Description" v04.003c

Chapter	What is new
6.10.	Revised CDM rating in Table 37 ($\pm 500V$ --> $\pm 250V$).

Preceding document: "ALS3-US R4 Hardware Interface Description" v04.003a

New document: "ALS3-US R4 Hardware Interface Description" v04.003b

Chapter	What is new
3.4.	Changed power saving default.
3.5.	Added RTC clock tolerance.

Preceding document: "ALS3-US R4 Hardware Interface Description" v04.003

New document: "ALS3-US R4 Hardware Interface Description" v04.003a

Chapter	What is new
6.9.	Revised test condition footnote for TTF in Table 35 .

Preceding document: "ALS3-US R4 Hardware Interface Description" v04.001

New document: "ALS3-US R4 Hardware Interface Description" v04.003

Chapter	What is new
--	Updated DocId.

Preceding document: "ALS3-US R4 Hardware Interface Description" v03.915

New document: "ALS3-US R4 Hardware Interface Description" v04.001

Chapter	What is new
Throughout document	Revised names for digital audio lines, and replaced names as follows: PCM_I2S_IN --> DIN, PCM_I2S_OUT --> DOUT, PCM_I2S_FSC --> FSC, PCM_I2S_CLK --> BCLK, I2S_MCLKOUT --> MCLK
1.4.1., 1.4.2.	Revised information with regard to the new Radio Equipment Directive (RED).
3.6.	Added remark about maximum USB cable length.
5.1.3.	New section ESD Protection for Antenna Interfaces .
10.1.	Added note for manufacturing information.

Preceding document: "ALS3-US R3 Hardware Interface Description" v03.011c

New document: "ALS3-US R4 Hardware Interface Description" v03.915

Chapter	What is new
Throughout document	Added Galileo as supported GNSS.
1.4.1.	Revised tables listing directives and standards.
2.1.	Added VoLTE support for multiple operators as new feature.
3.3.5.1.	Removed undertemperature shutdown URC.
6.10.	Revised CDM rating in Table 37 .
7.3.2.1.	Revised MSL label shown in Figure 56 .
10.1.	Updated ordering information.

Preceding document: "ALS3-US R3 Hardware Interface Description" v03.011b

New document: "ALS3-US R3 Hardware Interface Description" v03.011c

Chapter	What is new
3.4.	Revised description of power saving configuration and added Section 3.4.1. , Section 3.4.2. and Section 3.4.3. again.
3.6.1.	Revised section to include remark about data connections.
6.5.	Added comment for CCIN.
7.2.3.1.	Revised Table 38 listing reflow temperature ratings.
7.2.3.2.	Added remark on ramp-down rate.
10.1.	Added note for module label information.

Preceding document: "ALS3-US R3 Hardware Interface Description" v03.011a

New document: "ALS3-US R3 Hardware Interface Description" v03.011b

Chapter	What is new
2.1.	Added WB-AMR and USAT as supported features.
3.3.4.	Revised section including Figure 7 .
3.13.1.	Revised section to mention VCC μ C in PWR_IND circuit.

Preceding document: "ALS3-US R3 Hardware Interface Description" v03.011

New document: "ALS3-US R3 Hardware Interface Description" v03.011a

Chapter	What is new
1.4.1.	Revised some standard versions.
3.4.	Revised description of power save mode and removed previous sections 3.4.1, 3.4.2 and 3.4.2.
3.7.	Added further fixed baud rates at which ASC0 can be operated.
3.13.3.	Revised description of remote host wakeup functionality. Updated other sections accordingly.
3.13.6.	New section 700MHz Antenna Switch Control .
4/	Added remark about availability of dead reckoning synchronization signal.
6.5.	Added 700MHz antenna switch control functionality for GPIO2.
6.6.	Added current consumption rating for GPRS data transfer (4Tx/1Rx @ total mismatch). Revised average GSM/UMTS/LTE current consumption ratings while GNSS is ON. Revised current consumption ratings for IDLE mode listed in Table 29 .

Preceding document: "ALS3-US R3 Hardware Interface Description" v03.009

New document: "ALS3-US R3 Hardware Interface Description" v03.011

Chapter	What is new
6.5.	Host wakeup functionality added for GPIOs in Table 27
7.2.3.1.	Average ramp-down rate changed in Table 38

Preceding document: "ALS3-US Hardware Interface Description" v03.003

New document: "ALS3-US R3 Hardware Interface Description" v03.009

Chapter	What is new
Throughout document	Renamed ALS3-US to ALS3-US R3.
1.4.	Removed ECE-R 10 directive from Table 1 . Updated NAPRD version in Table 2 .
5.2.	Revised ratings for VGNSS in Figure 39 .
9.2.	Revised maximum antenna gain limits - added Table 40 .

Preceding document: "ALS3-US Hardware Interface Description" v02.502

New document: "ALS3-US Hardware Interface Description" v03.003

Chapter	What is new
Throughout document	Added real time clock (RTC) information. Added VDDLp line information. Added information on dead reckoning synchronization line.
1.4.1.	Updated section on directives and standards.
3.4.	Revised remarks about the AT commands AT^SCFG= "MEopMode/PwrSave" and AT^SCFG= "MEop-Mode/ExpectDTR".
3.5.	New section RTC Backup .
6.5.	Added characteristics for VDDLp line (RTC backup) in Table 27 .
7.2.3.1.	Revised description for average ramp up and ramp down rates in Table 38 .

Preceding document: "ALS3-US Hardware Interface Description" v01.032

New document: "ALS3-US Hardware Interface Description" v02.502

Chapter	What is new
Throughout document	Added second USIM interface.
3.13.4.	Revised LCI_IND to be configurable for all GPIOs.
6.5.	Revised characteristics of analog audio interface given in Table 27 .
6.7.3., 6.7.4., 6.7.5.	Updated audio mode characteristics and voiceband measurements.

Preceding document: "ALS3-US Hardware Interface Description" v01.438a

New document: "ALS3-US Hardware Interface Description" v01.032

Chapter	What is new
Throughout document	Added analog audio interface.
10.1.	Updated (evaluation) module's ordering information.

Preceding document: "ALS3-US Hardware Interface Description" v01.438

New document: "ALS3-US Hardware Interface Description" v01.438a

Chapter	What is new
3.7.	Removed notes on Multiplexer and specific usage of ASC0.
3.10.2.	Removed I ² S Slave mode.
3.12.	Added: GPIOs can be used to wake up the module from SLEEP mode.
6.2.	Shortened chapter.

Preceding document: "ALS3-US Hardware Interface Description" v01.431

New document: "ALS3-US Hardware Interface Description" v01.438

Chapter	What is new
Throughout document	Added support for I ² S interface (2nd digital audio interface). Renamed PCM related pads from PCM_* to PCM_I2S_*
3.3.1.	Added note on "^SYSSTART" URCs.
3.6.1.	New section Reducing Power Consumption .
3.10.1.	Revised section describing PCM interface.
3.13.3.	New section Remote Wakeup .

Preceding document: "ALS3-US Hardware Interface Description" v01.302

New document: "ALS3-US Hardware Interface Description" v01.431

Chapter	What is new
Throughout document	Added STATUS pad and low current indicator (LCI_IND) at GPIO6.
3.13.4.	New section Low Current Indicator .
3.13.5.	New section Network Connectivity and Technology Status Signals .

New document: "ALS3-US Hardware Interface Description" v01.302

Chapter	What is new
---	Initial document setup.

1/ Introduction

The document¹ describes the hardware of the ALS3-US R4 module, designed to connect to a cellular device application and the air interface. It helps you quickly retrieve interface specifications, electrical and mechanical details and information on the requirements to be considered for integrating further components.

1.1. Supported Products

This document applies to the following Kontron products:

- › ALS3-US R4 module

1.2. Related Documents

- [1] AT Command Set for your Kontron product
- [2] Release Notes for your Kontron product
- [3] Application Note 48: SMT Module Integration
- [4] Universal Serial Bus Specification Revision 2.0, April 27, 2000

1.3. Terms and Abbreviations

Abbreviation	Description
AMR	Adaptive Multirate
ANSI	American National Standards Institute
ARP	Antenna Reference Point
BIP	Bearer Independent Protocol
CE	Conformité Européene (European Conformity)
CS	Coding Scheme
CS	Circuit Switched
CSD	Circuit Switched Data
CSFB	Circuit Switched Fallback
DCS	Digital Cellular System
DL	Download
dnu	Do not use
DRX	Discontinuous Reception
DSB	Development Support Board
DTX	Discontinuous Transmission
EDGE	Enhanced Data rates for GSM Evolution
EFR	Enhanced Full Rate
EGSM	Extended GSM
EMC	Electromagnetic Compatibility
ESD	Electrostatic Discharge
ETS	European Telecommunication Standard
ETSI	European Telecommunications Standards Institute
FCC	Federal Communications Commission (U.S.)

¹ The document is effective only if listed in the appropriate Release Notes as part of the technical documentation delivered with your Kontron product.

Abbreviation	Description
FDD	Frequency Division Duplex
FR	Full Rate
GPRS	General Packet Radio Service
GSM	Global Standard for Mobile Communications
HiZ	High Impedance
HR	Half Rate
HSDPA	High Speed Downlink Packet Access
I/O	Input/Output
IMEI	International Mobile Equipment Identity
ISO	International Standards Organization
ITU	International Telecommunications Union
kbps	kbits per second
LED	Light Emitting Diode
LGA	Land Grid Array
LTE	Long term evolution
MBB	Moisture barrier bag
Mbps	Mbits per second
MCS	Modulation and Coding Scheme
MIMO	Multiple Input Multiple Output
MLCC	Multi Layer Ceramic Capacitor
MO	Mobile Originated
MS	Mobile Station, also referred to as TE
MSL	Moisture Sensitivity Level
MT	Mobile Terminated
nc	Not connected
NTC	Negative Temperature Coefficient
PCB	Printed Circuit Board
PCL	Power Control Level
PCS	Personal Communication System, also referred to as GSM 1900
PD	Pull Down resistor
PDU	Protocol Data Unit
PS	Packet Switched
PSK	Phase Shift Keying
PU	Pull Up resistor
QAM	Quadrature Amplitude Modulation
R&TTE	Radio and Telecommunication Terminal Equipment
RF	Radio Frequency
rfu	Reserved for future use
ROPR	Radio Output Power Reduction
RTC	Real Time Clock

Abbreviation	Description
Rx	Receive Direction
SAR	Specific Absorption Rate
SELV	Safety Extra Low Voltage
SIM	Subscriber Identification Module
SMD	Surface Mount Device
SMS	Short Message Service
SMT	Surface Mount Technology
SRAM	Static Random Access Memory
SRB	Signaling Radio Bearer
TE	Terminal Equipment
TPC	Transmit Power Control
TS	Technical Specification
Tx	Transmit Direction
UL	Upload
UMTS	Universal Mobile Telecommunications System
URC	Unsolicited Result Code
USB	Universal Serial Bus
UICC	USIM Integrated Circuit Card
USIM	UMTS Subscriber Identification Module
USAT	U/SIM Application Toolkit
WB-AMR	Wideband Adaptive Multirate
WCDMA	Wideband Code Division Multiple Access

1.4. Regulatory and Type Approval Information

1.4.1. Directives and Standards

ALS3-US R4 has been designed to comply with the directives and standards listed below.

It is the responsibility of the application manufacturer to ensure compliance of the final product with all provisions of the applicable directives and standards as well as with the technical specifications provided in the "ALS3-US R4 Hardware Interface Description".¹

Table 1: Directives



2014/53/EU	Directive of the European Parliament and of the council of 16 April 2014 on the harmonization of the laws of the Member States relating to the making available on the market of radio equipment and repealing Directive 1999/ 05/EC. The product is labeled with the CE conformity mark.	
2002/95/EC (RoHS 1) 2011/65/EC (RoHS 2)	Directive of the European Parliament and of the Council of 27 January 2003 (and revised on 8 June 2011) on the restriction of the use of certain hazardous substances in electrical and electronic equipment (RoHS)	

Table 2: Standards of North American type approval

CFR Title 47	Code of Federal Regulations, Part 22, Part 24 and Part 27; US Equipment Authorization FCC	
OET Bulletin 65 (Edition 97-01)	Evaluating Compliance with FCC Guidelines for Human Exposure to Radiofrequency Electromagnetic Fields	
UL 60 950-1	Product Safety Certification (Safety requirements)	
NAPRD.03 V5.30	Overview of PCS Type certification review board Mobile Equipment Type Certification and IMEI control PCS Type Certification Review board (PTCRB)	
RSS-102 I5, RSS-130 I1, RSS-132 I3, RSS-133 I6, RSS-139 I3, RSS-GEN I4	Canadian Standards	

Table 3: Standards of European type approval

3GPP TS 51.010-1	Digital cellular telecommunications system (Release 7); Mobile Station (MS) conformance specification;
ETSI EN 301 511 V12.5.1	Global System for Mobile communications (GSM); Mobile Stations (MS) equipment; Harmonized Standard covering the essential requirements of article 3.2 of Directive 2014/53/EU
GCF-CC V3.64	Global Certification Forum - Certification Criteria
ETSI EN 301 489-01 V2.2.3	Electromagnetic Compatibility (EMC) standard for radio equipment and services; Part 1: Common technical requirements; Harmonized Standard covering the essential requirements of article 3.1(b) of Directive 2014/53/EU and the essential requirements of article 6 of Directive 2014/30/EU
ETSI EN 301 489-19 V2.1.1	Electromagnetic Compatibility (EMC) standard for radio equipment and services; Part 19: Specific conditions for Receive Only Mobile Earth Stations (ROMES) operating in the 1,5 GHz band providing data communications and GNSS receivers operating in the RNSS band (ROGNSS) providing positioning, navigation, and timing data; Harmonized Standard covering the essential requirements of article 3.1(b) of Directive 2014/53/EU

¹ Manufacturers of applications which can be used in the US shall ensure that their applications have a PTCRB approval. For this purpose they can refer to the PTCRB approval of the respective module.

Table 3: Standards of European type approval

ETSI EN 301 489-52 V1.2.1	Electromagnetic Compatibility (EMC) standard for radio equipment and services; Part 52: Specific conditions for Cellular Communication Mobile and portable (UE) radio and ancillary equipment; Harmonized Standard covering the essential requirements of article 3.1(b) of Directive 2014/53/EU
ETSI EN 300 440 V2.1.1	Short Range Devices (SRD); Radio equipment to be used in the 1 GHz to 40 GHz frequency range; Harmonized Standard covering the essential requirements of article 3.2 of the Directive 2014/53/EU
EN 62311:2008	Assessment of electronic and electrical equipment related to human exposure restrictions for electromagnetic fields (0 Hz - 300 GHz)
IEC/EN 60950-1:2006+ A11:2009+A1:2010+ A12:2011+A2:2013	Safety of information technology equipment

Table 4: Requirements of quality

IEC 60068	Environmental testing
DIN EN 60529	IP codes

Table 5: Standards of the Ministry of Information Industry of the People’s Republic of China

SJ/T 11363-2006	“Requirements for Concentration Limits for Certain Hazardous Substances in Electronic Information Products” (2006-06).
SJ/T 11364-2006	<p data-bbox="499 266 1230 322">“Marking for Control of Pollution Caused by Electronic Information Products” (2006-06).</p> <p data-bbox="499 353 1479 524">According to the “Chinese Administration on the Control of Pollution caused by Electronic Information Products” (ACPEIP) the EPUP, i.e., Environmental Protection Use Period, of this product is 20 years as per the symbol shown here, unless otherwise marked. The EPUP is valid only as long as the product is operated within the operating limits described in the Hardware Interface Description.</p> <p data-bbox="499 555 1479 642">Please see Table 6 for an overview of toxic or hazardous substances or elements that might be contained in product parts in concentrations above the limits defined by SJ/T 11363-2006.</p>

**Table 6: Toxic or hazardous substances or elements with defined concentration limits**

部件名称 Name of the part	有毒有害物质或元素 Hazardous substances					
	铅 (Pb)	汞 (Hg)	镉 (Cd)	六价铬 (Cr(VI))	多溴联苯 (PBB)	多溴二苯醚 (PBDE)
金属部件 (Metal Parts)	○	○	○	○	○	○
电路模块 (Circuit Modules)	X	○	○	○	○	○
电缆及电缆组件 (Cables and Cable Assemblies)	○	○	○	○	○	○
塑料和聚合物部件 (Plastic and Polymeric parts)	○	○	○	○	○	○

O:
 表示该有毒有害物质在该部件所有均质材料中的含量均在SJ/T11363-2006 标准规定的限量要求以下。
 Indicates that this toxic or hazardous substance contained in all of the homogeneous materials for this part is below the limit requirement in SJ/T11363-2006.

X:
 表示该有毒有害物质至少在该部件的某一均质材料中的含量超出SJ/T11363-2006标准规定的限量要求。
 Indicates that this toxic or hazardous substance contained in at least one of the homogeneous materials used for this part *might exceed* the limit requirement in SJ/T11363-2006.

1.4.2. SAR requirements specific to portable mobiles

Mobile phones, PDAs or other portable transmitters and receivers incorporating a GSM/UMTS/LTE module must be in accordance with the guidelines for human exposure to radio frequency energy. This requires the Specific Absorption Rate (SAR) of portable ALS3-US R4 based applications to be evaluated and approved for compliance with national and/or international regulations.

Since the SAR value varies significantly with the individual product design manufacturers are advised to submit their product for approval if designed for portable use. For US markets the relevant directives are mentioned below. It is the responsibility of the manufacturer of the final product to verify whether or not further standards, recommendations or directives are in force outside these areas.

Products intended for sale on US markets

ES 59005/ANSI C95.1 Considerations for evaluation of human exposure to electromagnetic fields (EMFs) from mobile telecommunication equipment (MTE) in the frequency range 30MHz - 6GHz

IMPORTANT:





Manufacturers of portable applications based on ALS3-US R4 modules are required to have their final product certified and apply for their own FCC Grant and Industry Canada Certificate related to the specific portable mobile.

1.4.3. SELV Requirements

The power supply connected to the ALS3-US R4 module shall be in compliance with the SELV requirements defined in EN 60950-1.

1.4.4. Safety Precautions

The following safety precautions must be observed during all phases of the operation, usage, service or repair of any cellular terminal or mobile incorporating ALS3-US R4. Manufacturers of the cellular terminal are advised to convey the following safety information to users and operating personnel and to incorporate these guidelines into all manuals supplied with the product. Failure to comply with these precautions violates safety standards of design, manufacture and intended use of the product. Kontron assumes no liability for customer's failure to comply with these precautions.

	<p>When in a hospital or other health care facility, observe the restrictions on the use of mobiles. Switch the cellular terminal or mobile off, if instructed to do so by the guidelines posted in sensitive areas. Medical equipment may be sensitive to RF energy.</p> <p>The operation of cardiac pacemakers, other implanted medical equipment and hearing aids can be affected by interference from cellular terminals or mobiles placed close to the device. If in doubt about potential danger, contact the physician or the manufacturer of the device to verify that the equipment is properly shielded. Pacemaker patients are advised to keep their hand-held mobile away from the pacemaker, while it is on.</p>
	<p>Switch off the cellular terminal or mobile before boarding an aircraft. Make sure it cannot be switched on inadvertently. The operation of wireless appliances in an aircraft is forbidden to prevent interference with communications systems. Failure to observe these instructions may lead to the suspension or denial of cellular services to the offender, legal action, or both.</p>
	<p>Do not operate the cellular terminal or mobile in the presence of flammable gases or fumes. Switch off the cellular terminal when you are near petrol stations, fuel depots, chemical plants or where blasting operations are in progress. Operation of any electrical equipment in potentially explosive atmospheres can constitute a safety hazard.</p>
	<p>Your cellular terminal or mobile receives and transmits radio frequency energy while switched on. Remember that interference can occur if it is used close to TV sets, radios, computers or inadequately shielded equipment. Follow any special regulations and always switch off the cellular terminal or mobile wherever forbidden, or when you suspect that it may cause interference or danger.</p>
	<p>IMPORTANT! Cellular terminals or mobiles operate using radio signals and cellular networks. Because of this, connection cannot be guaranteed at all times under all conditions. Therefore, you should never rely solely upon any wireless device for essential communications, for example emergency calls.</p> <p>Remember, in order to make or receive calls, the cellular terminal or mobile must be switched on and in a service area with adequate cellular signal strength.</p> <p>Some networks do not allow for emergency calls if certain network services or phone features are in use (e.g. lock functions, fixed dialing etc.). You may need to deactivate those features before you can make an emergency call.</p> <p>Some networks require that a valid SIM card be properly inserted in the cellular terminal or mobile.</p>

2/ Product Concept

2.1. Key Features at a Glance

Feature	Implementation
<i>General</i>	
Frequency bands	GSM/GPRS/EDGE: Quad band, 850/900/1800/1900MHz UMTS/HSPA+: Triple band, 850 (BdV) / AWS (BdIV) / 1900MHz (BdII) LTE: Quad band, 700 (Bd17) / 850 (Bd5) / AWS (Bd4) / 1900MHz (Bd2)
GSM class	Small MS
Output power (according to Release 99)	Class 4 (+33dBm ±2dB) for EGSM850 Class 4 (+33dBm ±2dB) for EGSM900 Class 1 (+30dBm ±2dB) for GSM1800 Class 1 (+30dBm ±2dB) for GSM1900 Class E2 (+27dBm ± 3dB) for GSM 850 8-PSK Class E2 (+27dBm ± 3dB) for GSM 900 8-PSK Class E2 (+26dBm +3 /-4dB) for GSM 1800 8-PSK Class E2 (+26dBm +3 /-4dB) for GSM 1900 8-PSK Class 3 (+24dBm +1/-3dB) for UMTS 1900,WCDMA FDD BdII Class 3 (+24dBm +1/-3dB) for UMTS AWS, WCDMA FDD BdIV Class 3 (+24dBm +1/-3dB) for UMTS 850, WCDMA FDD BdV
Output power (according to Release 8)	Class 3 (+23dBm +-2dB) for LTE 1900, LTE FDD Bd2 Class 3 (+23dBm +-2dB) for LTE AWS, LTE FDD Bd4 Class 3 (+23dBm +-2dB) for LTE 850, LTE FDD Bd5 Class 3 (+23dBm +-2dB) for LTE 700, LTE FDD Bd17
Power supply	$3.3V \leq V_{BATT+} \leq 4.2V$
Operating temperature (board temperature)	Normal operation: -30°C to +85°C Restricted operation: -40°C to +95°C
Physical	Dimensions: 33mm x 29mm x 2.2mm Weight: approx. 4.5g
RoHS	All hardware components fully compliant with EU RoHS Directive
<i>LTE features</i>	
3GPP Release 9	UE CAT 3 supported DL 100Mbps, UL 50Mbps 2x2 MIMO in DL direction
<i>HSPA features</i>	
3GPP Release 8	UE CAT. 14, 24 DC-HSPA+ – DL 42Mbps HSUPA – UL 5.76Mbps Compressed mode (CM) supported according to 3GPP TS25.212
<i>UMTS features</i>	
3GPP Release 8	PS data rate – 384 kbps DL / 384 kbps UL

Feature	Implementation
<i>GSM / GPRS / EGPRS features</i>	
Data transfer	GPRS: <ul style="list-style-type: none"> › Multislot Class 12 › Mobile Station Class B › Coding Scheme 1 – 4 EGPRS: <ul style="list-style-type: none"> › Multislot Class 12 › EDGE E2 power class for 8 PSK › Downlink coding schemes – CS 1-4, MCS 1-9 › Uplink coding schemes – CS 1-4, MCS 1-9 › SRB loopback and test mode B › 8-bit, 11-bit RACH › 1 phase/2 phase access procedures › Link adaptation and IR › NACC, extended UL TBF › Mobile Station Class B
SMS	Point-to-point MT and MO Cell broadcast Text and PDU mode
<i>Software</i>	
AT commands	Hayes, 3GPP TS 27.007 and 27.005, and proprietary Kontron commands
Firmware update	Generic update from host application over USB and ASCO
U/SIM application toolkit	USAT letter c; with BIP
Audio	Audio speech codecs GSM: WB-AMR, AMR, EFR, FR, HR 3GPP: WB-AMR, AMR Speakerphone operation, echo cancellation, noise suppression, 9 ringing tones VoLTE support for multiple operators, with CSFB
<i>GNSS Features</i>	
Protocol	NMEA (for GPS, GLONASS and Galileo related sentences)
Modes	Standalone GNSS Assisted GNSS - Control plane - E911 - User plane - gpsOneXTRA™
General	Power saving modes Power supply for active antenna
<i>Interfaces</i>	
Module interface	Surface mount device with solderable connection pads (SMT application interface). Land grid array (LGA) technology ensures high solder joint reliability and provides the possibility to use an optional module mounting socket. For more information on how to integrate SMT modules see also [3]. This application note comprises chapters on module mounting and application layout issues as well as on additional SMT application development equipment.
Antenna	50Ω. GSM/UMTS/LTE main antenna, UMTS/LTE Diversity/MIMO antenna, (active/passive) GNSS antenna
USB	USB 2.0 High Speed (480Mbit/s) device interface
Serial interface	ASCO: <ul style="list-style-type: none"> › 8-wire modem interface with status and control lines, unbalanced, asynchronous › Adjustable baud rates: 115,200bps to 921,600bps › Supports RTS0/CTS0 hardware flow control

Feature	Implementation
UICC interface	2 UICC interfaces (switchable) Supported chip cards: UICC/SIM/USIM 3V, 1.8V
Audio	1 digital interface (PCM or I ² S) 1 analog interface with microphone feeding
Status	Signal line to indicate network connectivity state
RINGO	Signal line to indicate incoming calls and other types of URCs
<i>Power on/off, Reset</i>	
Power on/off	Switch-on by hardware signal IGT Switch-off by AT command (AT^SMSO) or IGT Automatic switch-off in case of critical temperature or voltage conditions
Reset	Orderly shutdown and reset by AT command
Emergency-off	Emergency-off by hardware signal EMERG_OFF if IGT is not active
<i>Special Features</i>	
Antenna	SAIC (Single Antenna Interference Cancellation) / DARP (Downlink Advanced Receiver Performance) Rx Diversity (receiver type 3i - 64-QAM) / MIMO
GPIO	10 I/O pins of the application interface programmable as GPIO. GPIOs can be configured as low current indicator (LCI). GPIOs can be configured for antenna diagnosis. GPIO1 can be configured as dead reckoning synchronization signal. GPIO2 can be configured as 700MHz antenna switch control signal. GPIOs can be configured as remote host wakeup lines. Programming is done via AT commands.
ADC inputs	Analog-to-Digital Converter with three unbalanced analog inputs for (external) antenna diagnosis.
<i>Evaluation kit</i>	
Evaluation module	ALS3-US R4 module soldered onto a dedicated PCB that can be connected to an adapter in order to be mounted onto the DSB75.
DSB75	DSB75 Development Support Board designed to test and type approve Kontron modules and provide a sample configuration for application engineering. A special adapter is required to connect the ALS3-US R4 evaluation module to the DSB75.

2.2. ALS3-US R4 System Overview

Figure 1: ALS3-US R4 system overview

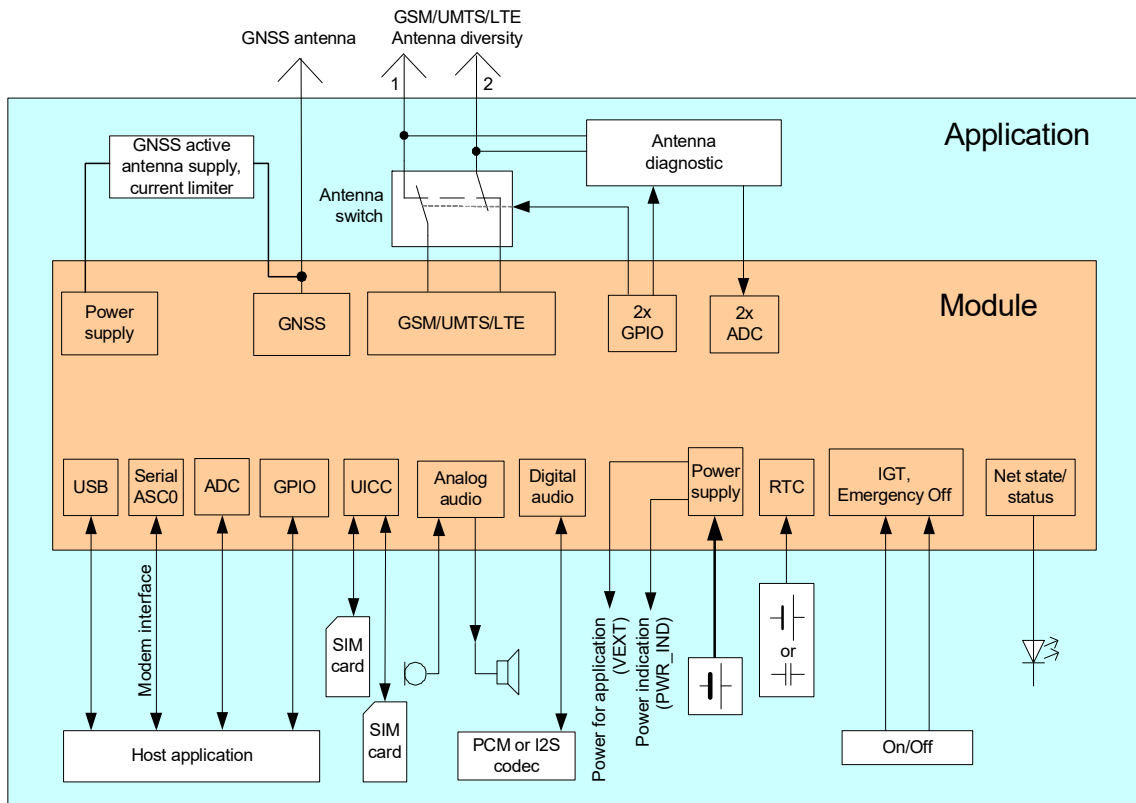

2.3. Circuit Concept

Figure 2 shows a block diagram of the ALS3-US R4 module and illustrates the major functional components:

Baseband block:

- › GSM/UMTS/LTE controller/transceiver/power supply
- › Stacked Flash/RAM memory with multiplexed address data bus
- › Audio codec
- › Application interface (SMT with connecting pads)

RF section:

- › RF transceiver
- › RF power amplifier/frontend
- › RF filter
- › GNSS receiver/Front end
- › Antenna pad

Figure 2: ALS3-US R4 block diagram

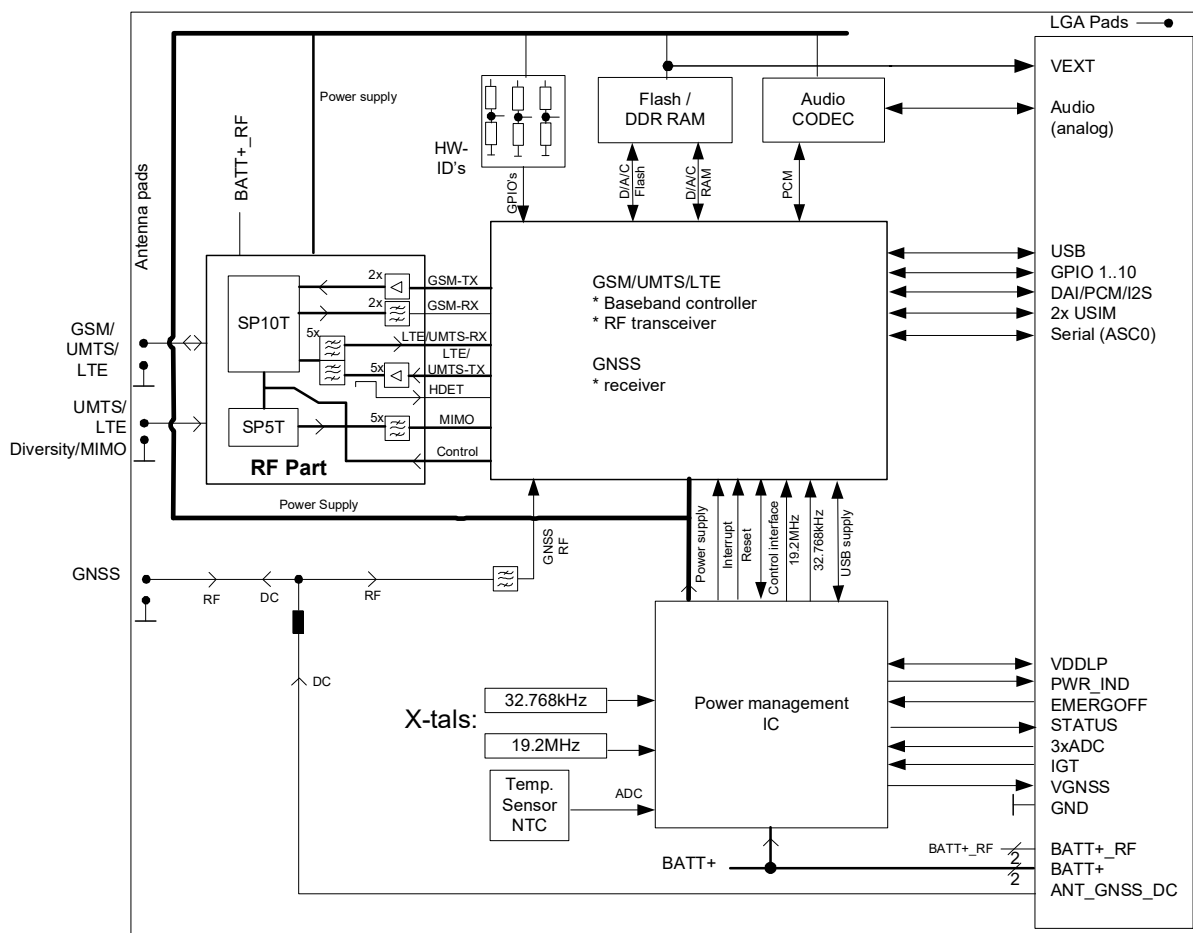

3/ Application Interface

ALS3-US R4 is equipped with an SMT application interface (LGA pads) that connects to the external application. The host interface incorporates several sub-interfaces described in the following sections:

- › Operating modes - see [Section 3.1](#).
- › Power supply - see [Section 3.2](#).
- › RTC backup - see [Section 3.5](#).
- › Serial interface USB - see [Section 3.6](#).
- › Serial interface ASC0 - [Section 3.7](#).
- › UICC/SIM/USIM interface - see [Section 3.8](#).
- › Analog audio interface - see [Section 3.9](#).
- › Digital audio interface (PCM or I²S) - see [Section 3.10](#).
- › ADC interface - [Section 3.11](#).
- › GPIO interface - [Section 3.12](#).
- › Control and status lines: PWR_IND, STATUS, RING0, STATUS, LCI - see [Section 3.13](#).

3.1. Operating Modes

The table below briefly summarizes the various operating modes referred to in the following chapters.

Table 7: Overview of operating modes

Mode	Function	
Normal operation	GSM / GPRS / UMTS / HSPA / LTE SLEEP	Power saving set automatically when no call is in progress and the USB connection is detached and no active communication via ASC0. Also, the GNSS active antenna mode has to be turned off or set to "auto".
	GSM / GPRS / UMTS / HSPA / LTE IDLE	Power saving disabled or an USB connection active, but no data transfer in progress.
	GPRS DATA	GPRS data transfer in progress. Power consumption depends on network settings (e.g. power control level), uplink / downlink data rates and GPRS configuration (e.g. used multislot settings).
	EGPRS DATA	EGPRS data transfer in progress. Power consumption depends on network settings (e.g. power control level), uplink / downlink data rates and EGPRS configuration (e.g. used multislot settings).
	UMTS DATA	UMTS data transfer in progress. Power consumption depends on network settings (e.g. TPC Pattern) and data transfer rate.
	HSPA DATA	HSPA data transfer in progress. Power consumption depends on network settings (e.g. TPC Pattern) and data transfer rate.
	LTE DATA	LTE data transfer in progress. Power consumption depends on network settings (e.g. TPC Pattern) and data transfer rate.
Power Down	Normal shutdown after sending the AT^SMSO command. Only a voltage regulator is active for powering the RTC. Software is not active. Interfaces are not accessible. Operating voltage (connected to BATT+) remains applied.	
Airplane mode	Airplane mode shuts down the radio part of the module, causes the module to log off from the GSM/GPRS network and disables all AT commands whose execution requires a radio connection. Airplane mode can be controlled by AT command (see [1]).	

3.2. Power Supply

ALS3-US R4 needs to be connected to a power supply at the SMT application interface - 4 lines BATT+, and GND. There are two separate voltage domains for BATT+:

- › BATT+_RF with 2 lines for the RF power amplifier supply
- › BATT+ with 2 lines for the general power management.

The main power supply from an external application has to be a single voltage source and has to be expanded to two sub paths (star structure). Each voltage domain must be decoupled by application with low ESR capacitors ($\geq 47\mu\text{F}$ MLCC @ BATT+; $\geq 4 \times 47\mu\text{F}$ MLCC @ BATT+_RF) as close as possible to LGA pads. [Figure 3](#) shows a sample circuit for decoupling capacitors for BATT+.

Figure 3: Decoupling capacitor(s) for BATT+

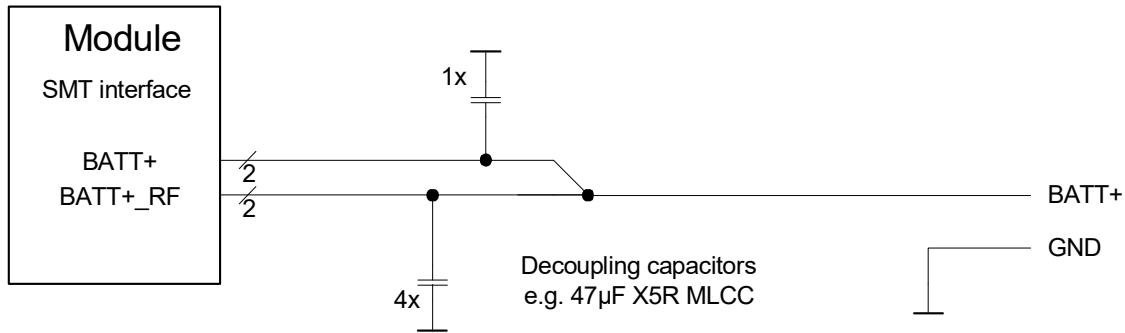

In addition, the VDDLp pad may be connected to an external capacitor or a battery to backup the RTC (see [Section 3.5](#)). Please note that for proper module startup the voltage at BATT+ should be higher than at VDDLp.

The power supply of ALS3-US R4 must be able to provide the peak current during the uplink transmission.

All key functions for supplying power to the device are handled by the power management IC. It provides the following features:

- › Stabilizes the supply voltages for the baseband using switching regulators and low drop linear voltage regulators.
- › Switches the module's power voltages for the power-up and -down procedures.
- › Delivers, across the VEXT line, a regulated voltage for an external application.
- › LDO to provide SIM power supply.

3.2.1. Minimizing Power Losses

When designing the power supply for your application please pay specific attention to power losses. Ensure that the input voltage $V_{\text{BATT+}}$ never drops below 3.3V on the ALS3-US R4 board, not even in a transmit burst where current consumption can rise to typical peaks of 2A. It should be noted that ALS3-US R4 switches off when exceeding these limits. Any voltage drops that may occur in a transmit burst should not exceed 400mV to ensure the expected RF performance in 2G networks.

The module switches off if the minimum battery voltage (V_{BATTmin}) is reached.

Example:

$V_{\text{Imin}} = 3.3\text{V}$

$D_{\text{max}} = 0.4\text{V}$

$V_{\text{BATTmin}} = V_{\text{Imin}} + D_{\text{max}}$

$V_{\text{BATTmin}} = 3.3\text{V} + 0.4\text{V} = 3.7\text{V}$

Figure 4: Power supply limits during transmit burst

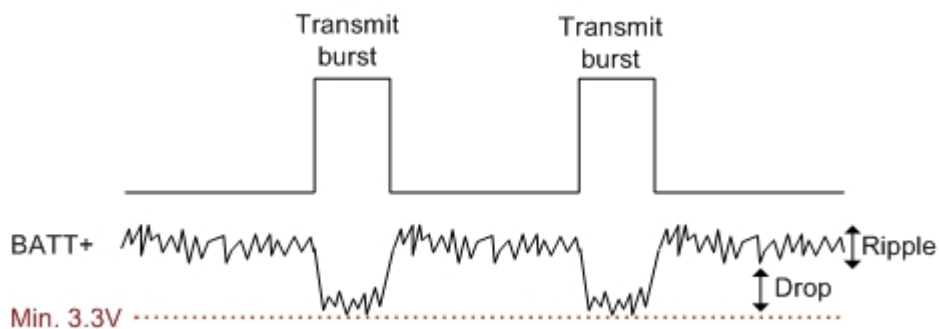

3.2.2. Monitoring Power Supply by AT Command

To monitor the supply voltage you can use the AT[^]SBV command which returns the averaged value related to BATT+ and GND at the SMT application interface.

The module continuously measures the voltage at intervals depending on the operating mode of the RF interface. The duration of measuring ranges from 0.5 seconds in DATA mode to 50 seconds when ALS3-US R4 is in Limited Service (deregistered). The displayed voltage (in mV) is averaged over the last measuring period before the AT[^]SBV command was executed.

3.3. Power-Up / Power-Down Scenarios

In general, be sure not to turn on ALS3-US R4 while it is beyond the safety limits of voltage and temperature stated in [Section 6.1](#). ALS3-US R4 immediately switches off after having started and detected these inappropriate conditions. In extreme cases this can cause permanent damage to the module.

3.3.1. Turn on ALS3-US R4

When the ALS3-US R4 module is in Power Down mode, it can be started to Normal mode by driving the IGT (ignition) line to ground. It is recommended to use an open drain/collector driver to avoid current flowing into this signal line. Pulling this signal low triggers a power-on sequence. To turn on ALS3-US R4, IGT has to be kept active at least 100 milliseconds. After turning on ALS3-US R4, IGT should be set inactive to prevent the module from turning on again after a shut down by AT command or EMERG_OFF. For details on signal states during startup see also [Section 3.3.2](#).

Figure 5: Power-on with IGT

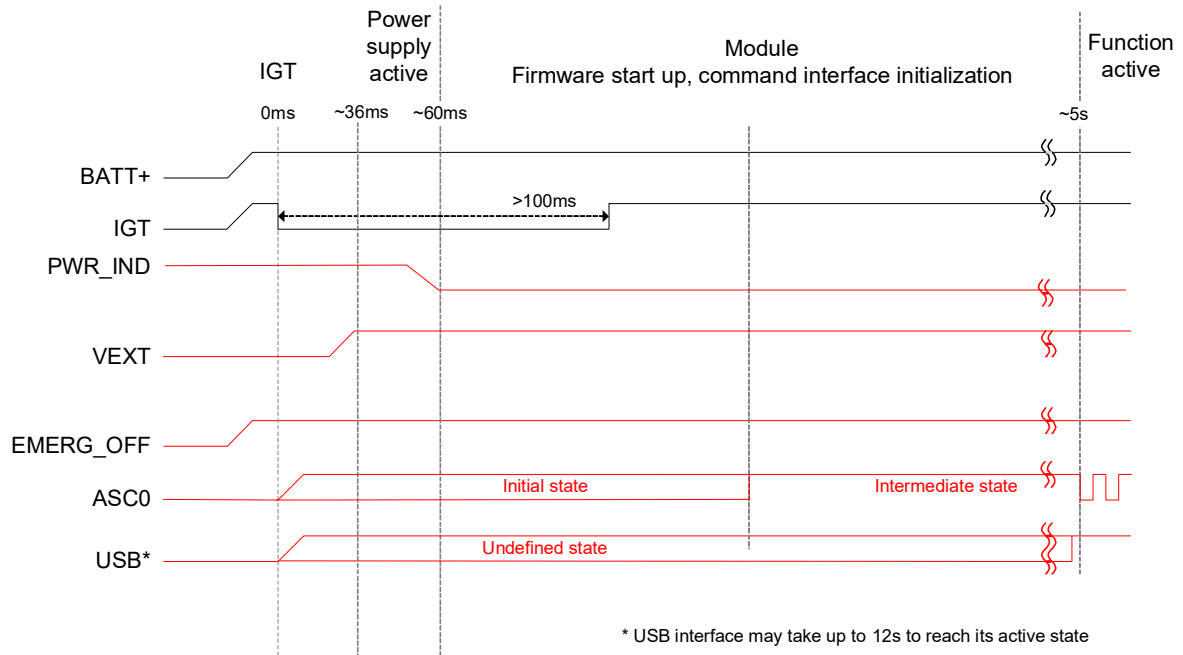

Note: After power up IGT should remain high. Also note that with a USB connection the USB host may take up to 12 seconds to set up the virtual COM port connection.

After startup or mode change the following URCs are sent to every port able to receive AT commands indicating the module's ready state:

- "^SYSSTART" indicates that the module has entered Normal mode.
- "^SYSSTART AIRPLANE MODE" indicates that the module has entered Airplane mode.

These URCs notify the external application that the first AT command can be sent to the module. If these URCs are not used to detect then the only way of checking the module's ready state is polling. To do so, try to send characters (e.g. "at") until the module is responding.

3.3.2. Signal States after Startup

Table 8 describes the various states each interface signal passes through after startup and during operation.

Signals are in an initial state while the module is initializing. Once the startup initialization has completed, i.e. when the software is running, all signals are in defined state. The state of several signals will change again once the respective interface is activated or configured by AT command.

Table 8: Signal states

Signal name	Power on reset	Startup phase	State after first firmware initialization After 4-5s
	Duration appr. 60ms	Duration appr. 4s	
CCINx	PD and PU (24k)	PU(24k)	I, PU(24k)
CCRSTx	Not driven (similar PD)	Not driven (similar PD)	O, L ¹ O, H ²
CCIOx	PD(10k)	PD(10k)	PD(10k) ¹ PU(10k) ²
CCCLKx	Not driven (similar PD)	Not driven (similar PD)	O, L ¹ Clock ²
CCVCCx	Off	Off	Off ¹ 1.8V/3V ²
RXD0	PD	PU	PU
TXD0	PD	PD	PD
CTS0	PD	PD	PD
RTS0	PU and PD	PD	PD
DTR0	PD	PD	PD
DCD0	PD	PU ³	PD
DSR0	PD	PD	PD
RING0	PD	O, H	O, H
DIN	PU	PD	PD
BCLK	PD	PD	PD
FSC	PD	PD	PD
DOUT	PD	PD	PD
MCLK	PD	PD	PD
PWR_IND	Z	O, L	O, L
STATUS	PD	PD	PD
EMERG_OFF	PU	I, PU	I, PU
IGT	I, PU	I, PU	I, PU
GPIO1...10 ⁴	PD	PD	PD

¹ If CCIN = High level

² If CCIN = Low level

³ No external pull down allowed during this phase.

⁴ Please note that during its startup phase the GPIO8 signal will be in an active low state for approx. 80ms.

L = Low level H = High level I = Input O = Output	PD = Pull down resistor with approx. 100k ¹ PD(...k) = Pull down resistor with ...k PU = Pull up resistor with approx. 100k PU(...k) = Pull up resistor with ...k, Z = High impedance
--	--

¹ Internal pulls are implemented using JFETs; strengths vary between devices, possible range: 55k...390k

3.3.3. Turn off ALS3-US R4 Using AT Command

The best and safest approach to powering down ALS3-US R4 is to issue the AT[^]SMSO command. This procedure lets ALS3-US R4 log off from the network and allows the software to enter into a secure state and save data before disconnecting the power supply. The mode is referred to as Power Down mode. In this mode, only the RTC stays active. After sending AT[^]SMSO do not enter any other AT commands. While powering down the module may still send some URCs. To verify that the module turned off it is possible to monitor the PWR_IND signal. A high state of the PWR_IND signal line indicates that the module is being switched off as shown in Figure 6.

Be sure not to disconnect the supply voltage V_{BATT+} before the module's switch off procedure has been completed and the VEXT signal has gone low. Otherwise you run the risk of losing data. Signal states during switch off are shown in Figure 6.

While ALS3-US R4 is in Power Down mode the application interface is switched off and must not be fed from any other source. Therefore, your application must be designed to avoid any current flow into any digital signal lines of the application interface. No special care is required for the USB interface which is protected from reverse current.

Figure 6: Signal states during turn-off procedure

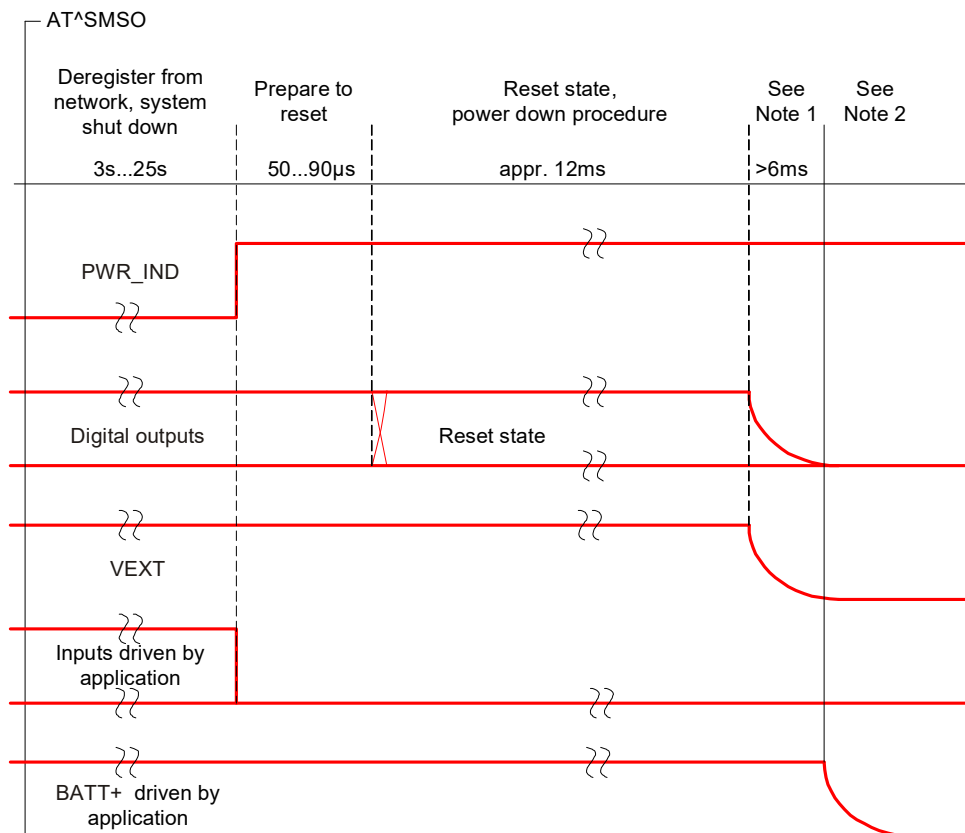

Note 1: Depending on capacitance load from host application

Note 2: The power supply voltage (BATT+) may be disconnected or switched off only after the VEXT went low.

Note 3: After module shutdown by means of AT command is completed, please allow for a time period of at least 1 second before restarting the module.

3.3.4. Turn off ALS3-US R4 Using IGT Line

The IGT line can be configured for use in two different switching modes: You can set the IGT line to switch on the module only, or to switch it on and off. The switching mode is determined by the parameter "MESHUTDOWN/OnIgnition" of the AT^SCFG command. This approach is useful for external application manufacturers who wish to have an ON/OFF switch installed on the host device.

By factory default, the ON/OFF switch mode of IGT is disabled:

```
at^scfg=meshutdown/onignition          # Query the current status of IGT.
^SCFG: "MESHUTDOWN/OnIgnition","off"   # IGT can be used only to switch on ALS3-US R4.
OK                                       IGT works as described in Section 3.3.1..
```

To configure IGT for use as ON/OFF switch:

```
at^scfg=meshutdown/onignition          # Enable the ON/OFF switch mode of IGT.
^SCFG: "MESHUTDOWN/OnIgnition","on"   # IGT can be used to switch on and off ALS3-US R4.
OK
```

Take great care before changing the switching mode of the IGT line. To ensure that the IGT line works properly as ON/OFF switch it is of vital importance that the following conditions are met:

Switch-on condition:

If the ALS3-US R4 is off, the IGT line must be asserted for at least 100 milliseconds before being released.

Switch-off condition:

If the ALS3-US R4 is on, the IGT line must be asserted for at least 2.15 seconds before being released. The module switches off after the line is released. The switch-off routine is identical with the procedure initiated by AT^SMSO, i.e. the software performs an orderly shutdown as described in Section 3.3.3.. Before switching off the module wait at least 5 seconds after startup.

Figure 7: Timing of IGT if used as ON/OFF switch

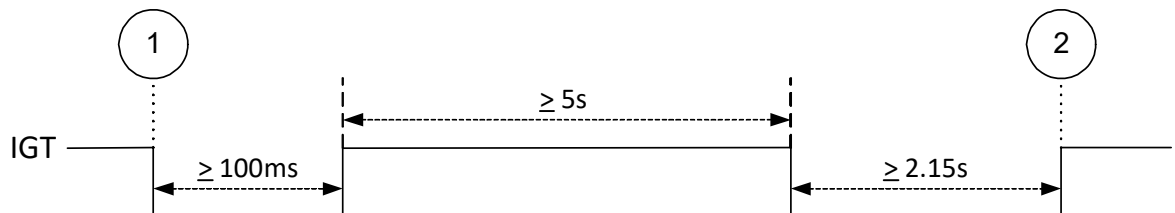

1 – Triggers switch ON routine

2 – Triggers switch OFF routine

3.3.5. Automatic Shutdown

Automatic shutdown takes effect if:

- The ALS3-US R4 board exceeds the critical limits of overtemperature
- Undervoltage or overvoltage is detected

The automatic shutdown procedure is equivalent to the power down initiated with the AT^SMSO command, i.e. ALS3-US R4 logs off from the network and the software enters a secure state avoiding loss of data.

Alert messages transmitted before the device switches off are implemented as Unsolicited Result Codes (URCs). The presentation of the temperature URCs can be enabled or disabled with the AT commands AT^SCTM. The URC presentation mode varies with the condition, please see Section 3.3.5.1. to Section 3.3.5.4. for details. For further instructions on AT commands refer to [1].

3.3.5.1. Thermal Shutdown

The board temperature is constantly monitored by an internal NTC resistor located on the PCB. The values detected by the NTC resistor are measured directly on the board and therefore, are not fully identical with the ambient temperature.

Each time the board temperature goes out of range or back to normal, ALS3-US R4 instantly displays an alert (if enabled).

- ▶ URCs indicating the level "1" or "-1" allow the user to take appropriate precautions, such as protecting the module from exposure to extreme conditions. The presentation of the URCs depends on the settings selected with the AT^SCTM write command:
 AT^SCTM=1: Presentation of URCs is always enabled.
 AT^SCTM=0 (default): Presentation of URCs is enabled during the 2 minutes guard period after start-up of ALS3-US R4. After expiry of the 2 minutes guard period, the presentation will be disabled, i.e. no URCs with alert levels "1" or "-1" will be generated.
- ▶ URCs indicating the level "2" are instantly followed by an orderly shutdown. The presentation of these URCs is always enabled, i.e. they will be output even though the factory setting AT^SCTM=0 was never changed.

The maximum temperature ratings are stated in [Section 6.2.](#) Refer to [Table 9](#) for the associated URCs.

Table 9: Temperature dependent behavior

Sending temperature alert (2 minutes after ALS3-US R4 start-up, otherwise only if URC presentation enabled)	
^SCTM_B: 1	Caution: Board close to overtemperature limit, i.e., board is 5°C below overtemperature limit.
^SCTM_B: -1	Caution: Board close to undertemperature limit, i.e., board is 5°C above undertemperature limit.
^SCTM_B: 0	Board back to uncritical temperature range, i.e., board is 6°C below its over- or above its undertemperature limit.
Automatic shutdown (URC appears no matter whether or not presentation was enabled)	
^SCTM_B: 2	Alert: Board equal or beyond overtemperature limit. ALS3-US R4 switches off.

The AT^SCTM command can also be used to check the present status of the board. Depending on the selected mode, the read command returns the current board temperature in degrees Celsius or only a value that indicates whether the board is within the safe or critical temperature range. See [\[1\]](#) for further instructions.

3.3.5.2. Deferred Shutdown at Extreme Temperature Conditions

In the following cases, automatic shutdown will be deferred if a critical temperature limit is exceeded:

- ▶ While an emergency call is in progress.
- ▶ During a two minute guard period after power-up. This guard period has been introduced in order to allow for the user to make an emergency call. The start of any one of these calls extends the guard period until the end of the call. Any other network activity may be terminated by shutdown upon expiry of the guard time.

While in a "deferred shutdown" situation, ALS3-US R4 continues to measure the temperature and to deliver alert messages, but deactivates the shutdown functionality. Once the 2 minute guard period is expired or the call is terminated, full temperature control will be resumed. If the temperature is still out of range, ALS3-US R4 switches off immediately (without another alert message).

CAUTION! Automatic shutdown is a safety feature intended to prevent damage to the module.

Extended usage of the deferred shutdown facilities provided may result in damage to the module, and possibly other severe consequences.

3.3.5.3. Undervoltage Shutdown

If the measured battery voltage is no more sufficient to set up a call the following URC will be presented:

^SBC: Undervoltage.

The URC indicates that the module is close to the undervoltage threshold. If undervoltage persists the module keeps sending the URC several times before switching off automatically.

This type of URC does not need to be activated by the user. It will be output automatically when fault conditions occur.

3.3.5.4. Overvoltage Shutdown

The overvoltage shutdown threshold is 100mV above the maximum supply voltage $V_{\text{BATT+}}$ specified in [Table 27](#).

When the supply voltage approaches the overvoltage shutdown threshold the module will send the following URC:

^SBC: Overvoltage warning

This alert is sent once.

When the overvoltage shutdown threshold is exceeded the module will send the following URC

^SBC: Overvoltage shutdown

before it shuts down cleanly.

This type of URC does not need to be activated by the user. It will be output automatically when fault conditions occur.

Keep in mind that several ALS3-US R4 components are directly linked to BATT+ and, therefore, the supply voltage remains applied at major parts of ALS3-US R4, even if the module is switched off. Especially the power amplifier is very sensitive to high voltage and might even be destroyed.

3.3.6. Turn off ALS3-US R4 in Case of Emergency

Caution: Use the EMERG_OFF line only when, due to serious problems, the software is not responding for more than 5 seconds. Pulling the EMERG_OFF line causes the loss of all information stored in the volatile memory. Therefore, this procedure is intended only for use in case of emergency, e.g. if ALS3-US R4 does not respond, if reset or shutdown via AT command fails.

The EMERG_OFF line is available on the application interface and can be used to switch off the module. To control the EMERG_OFF line it is recommended to use an open drain / collector driver.

To switch off, the EMERG_OFF line must be pulled to ground for longer than 40 milliseconds. After the 40 milliseconds and an additional delay period of 500 milliseconds the module shuts down as shown in Figure 8.

Figure 8: Shutdown by EMERG_OFF signal

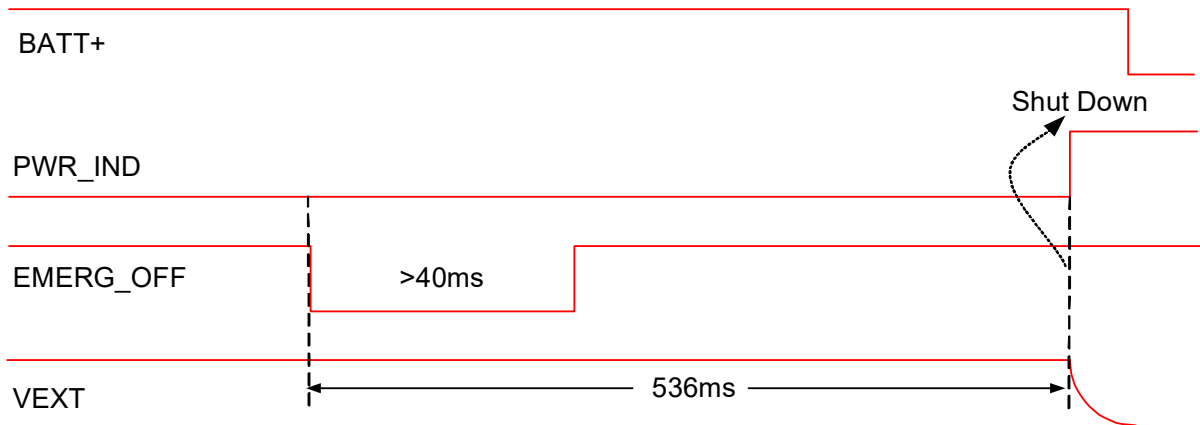

Note: The power supply voltage (BATT+) may be disconnected or switched off only after having reached Shut Down as indicated by the PWR_IND signal going high. The power supply has to be available (again) before the module is restarted.

3.4. Power Saving

The power saving behavior is further configurable by AT command:

- ▶ AT^SCFG="MEopMode/PwrSave": The default state is mentioned in [1]. While inactive, the module stays in power save (SLEEP) state, waking up only upon any of the following events:
 - Cyclically to meet basic technical demands, e.g. network requirements (such as regularly listening to paging messages from the base station as described in Section 3.4.1., Section 3.4.2. and Section 3.4.3..
 - Cyclically after expiry of a configured power saving period.
 - Data at any interface port, e.g., URCs for incoming calls.
 - A level state transition at GPIO1, GPIO3, GPIO4, GPIO5 and GPIO9.
- ▶ AT^SCFG="MEopMode/ExpectDTR": Power saving will take effect only if there is no transmission data pending on any of the module's USB ports. The expect DTR AT command ensures that data becoming pending on any USB port before an external application has signaled its readiness to receive the data is discarded. By default this behavior is enabled for all available USB CDC ACM and CDC ECM ports.
- ▶ AT^SCFG="Radio/OutputPowerReduction": Output power reduction is possible for the module in GPRS multislots scenarios to reduce its output power according to 3GPP 45.005 section.

Please refer to [1] for more information on the above AT commands used to configure the module's power saving behavior.

The implementation of the USB host interface also influences the module's power saving behavior and therefore its current consumption. For more information see Section 3.6.. Another feature influencing the current consumption is the configuration of the GNSS antenna interface. For details see Section 6.9.. Also note that the command AT^SBV, which allows to monitor the module's power supply, is only available if the module is not in SLEEP mode. This means, the shorter the power saving periods, the faster and more precise the module's power supply monitoring is going to be (see also Section 3.2.2.).

3.4.1. Power Saving while Attached to GSM Networks

The power saving possibilities while attached to a GSM network depend on the paging timing cycle of the base station. The duration of a paging timing cycle can be calculated using the following formula:

$$t = 4.615 \text{ ms (TDMA frame duration)} * 51 \text{ (number of frames)} * \text{DRX value.}$$

DRX (Discontinuous Reception) is a value from 2 to 9, resulting in paging timing cycles between 0.47 and 2.12 seconds. The DRX value of the base station is assigned by the GSM network operator.

Now, a paging timing cycle consists of the actual fixed length paging plus a variable length pause before the next paging. In the pauses between listening to paging messages, the module resumes power saving, as shown in Figure 9.

Figure 9: Power saving and paging in GSM networks

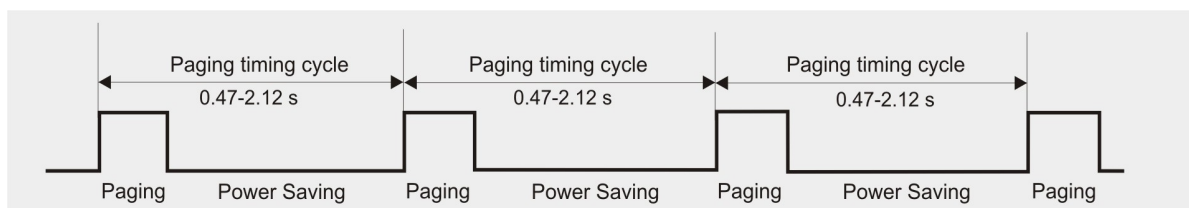

The varying pauses explain the different potential for power saving. The longer the pause the less power is consumed.

Generally, power saving depends on the module's application scenario and may differ from the above mentioned normal operation. The power saving interval may be shorter than 0.47 seconds or longer than 2.12 seconds.

3.4.2. Power Saving while Attached to WCDMA Networks

The power saving possibilities while attached to a WCDMA network depend on the paging timing cycle of the base station.

During normal WCDMA operation, i.e., the module is connected to a WCDMA network, the duration of a paging timing cycle varies. It may be calculated using the following formula:

$$t = 2^{\text{DRX value}} * 10 \text{ ms (WCDMA frame duration)}.$$

DRX (Discontinuous Reception) in WCDMA networks is a value between 6 and 9, thus resulting in paging timing cycles between 0.64 and 5.12 seconds. The DRX value of the base station is assigned by the WCDMA network operator.

Now, a paging timing cycle consists of the actual fixed length paging plus a variable length pause before the next paging. In the pauses between listening to paging messages, the module resumes power saving, as shown in [Figure 10](#).

Figure 10: Power saving and paging in WCDMA networks

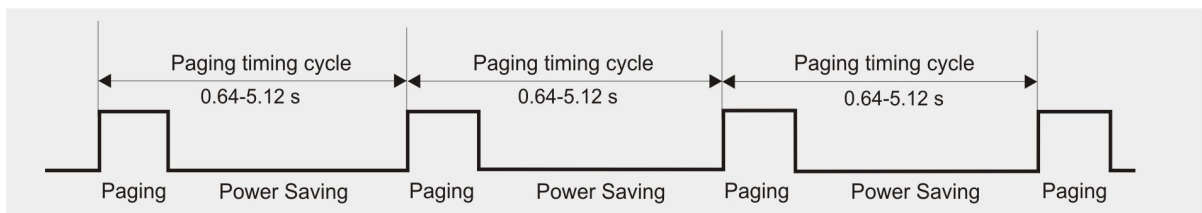

The varying pauses explain the different potential for power saving. The longer the pause the less power is consumed.

Generally, power saving depends on the module's application scenario and may differ from the above mentioned normal operation. The power saving interval may be shorter than 0.64 seconds or longer than 5.12 seconds.

3.4.3. Power Saving while Attached to LTE Networks

The power saving possibilities while attached to an LTE network depend on the paging timing cycle of the base station.

During normal LTE operation, i.e., the module is connected to an LTE network, the duration of a paging timing cycle varies. It may be calculated using the following formula:

$$t = \text{DRX Cycle Value} * 10 \text{ ms}$$

DRX cycle value in LTE networks is any of the four values: 32, 64, 128 and 256, thus resulting in paging timing cycles between 0.32 and 2.56 seconds. The DRX cycle value of the base station is assigned by the LTE network operator.

Now, a paging timing cycle consists of the actual fixed length paging plus a variable length pause before the next paging. In the pauses between listening to paging messages, the module resumes power saving, as shown in [Figure 11](#).

Figure 11: Power saving and paging in LTE networks

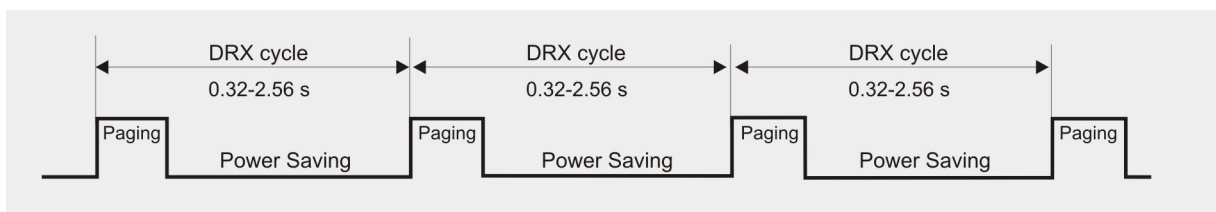

The varying pauses explain the different potential for power saving. The longer the pause the less power is consumed.

Generally, power saving depends on the module's application scenario and may differ from the above mentioned normal operation. The power saving interval may be shorter than 0.32 seconds or longer than 2.56 seconds.

3.4.4. Wake-up via RTS0

RTS0 can be used to wake up ALS3-US R4 from SLEEP mode. Assertion of RTS0 (i.e., toggle from inactive high to active low) serves as wake up event, thus allowing an external application to almost immediately terminate power saving. After RTS0 assertion, the CTS0 line signals module wake up, i.e., readiness of the AT command interface. It is therefore recommended to enable RTS/CTS flow control (default setting).

Figure 12 shows the described RTS0 wake up mechanism.

Figure 12: Wake-up via RTS0

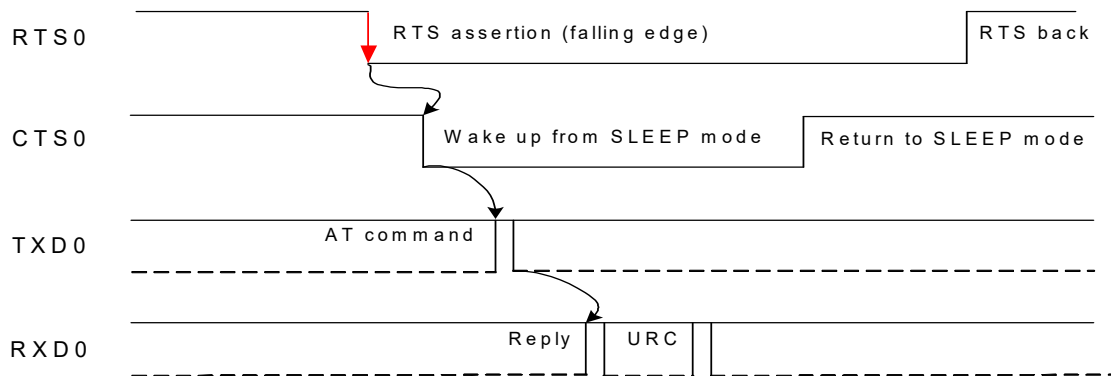

3.5. RTC Backup

The internal Real Time Clock of ALS3-US R4 is supplied from a separate voltage regulator in the power supply component which is also active when ALS3-US R4 is in Power Down mode and BATT+ is available. An alarm function is provided that allows to wake up ALS3-US R4. When the alarm time is reached the module wakes up to the functionality level (AT+CFUN) that was valid before power down. For example, if the module was in Airplane mode before power down, the module will wake up without logging on to the GSM/UMTS/LTE network.

In addition, you can use the VDDL P pad on the SMT interface to backup the RTC from an external capacitor or a battery (rechargeable or non-chargeable). The capacitor is charged from the internal LDO of ALS3-US R4. If the voltage supply at BATT+ is disconnected the RTC can be powered by the capacitor. The size of the capacitor determines the duration of buffering when no voltage is applied to ALS3-US R4, i.e. the greater the capacitor the longer ALS3-US R4 will save the date and time. It limits the output current of an empty capacitor or battery. If the RTC is only powered by VDDL P, the clock generator has an accuracy of $\pm 15\%$.

Figure 13 show various sample configurations.

Figure 13: RTC supply variants

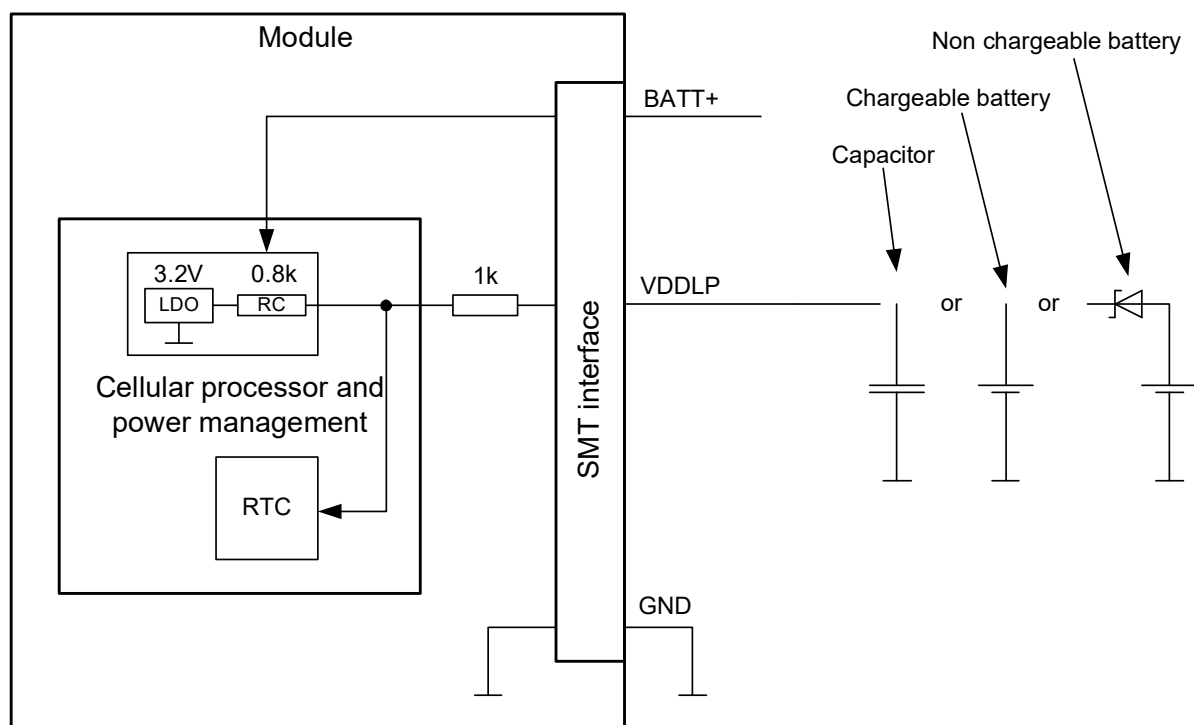

3.6. USB Interface

ALS3-US R4 supports a USB 2.0 High Speed (480Mbps) device interface. The USB interface is primarily intended for use as command and data interface and for downloading firmware.

The USB host is responsible for supplying the VUSB_IN line. This line is for voltage detection only. The USB part (driver and transceiver) is supplied by means of BATT+. This is because ALS3-US R4 is designed as a self-powered device compliant with the "Universal Serial Bus Specification Revision 2.0"¹.

Figure 14: USB circuit

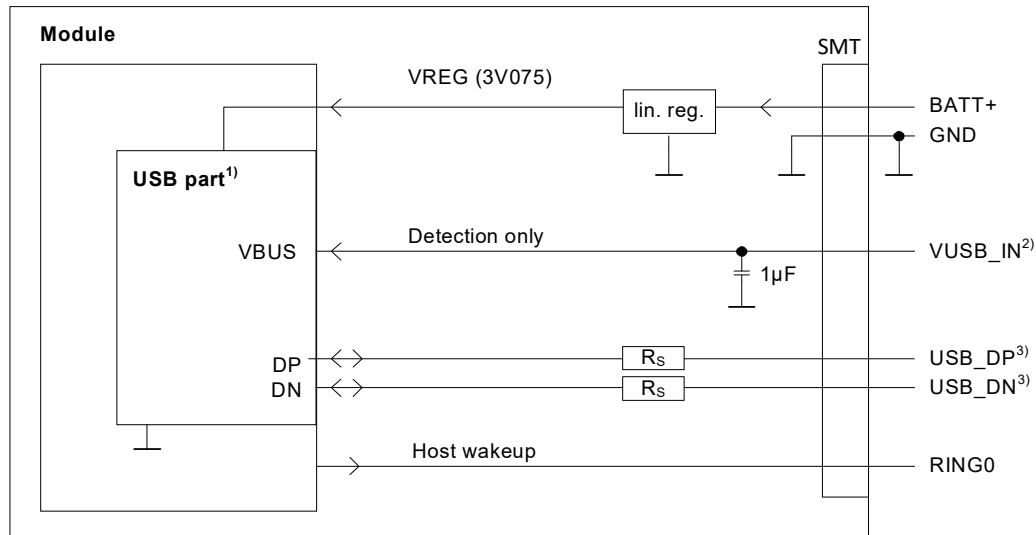

¹⁾ All serial (including R_s) and pull-up resistors for data lines are implemented.

²⁾ Since VUSB_IN is used for detection only it is recommended not to add any further blocking capacitors on the VUSB_IN line.

³⁾ If the USB interface is operated in High Speed mode (480MHz), it is recommended to take special care routing the data lines USB_DP and USB_DN. Application layout should in this case implement a differential impedance of 90 ohms for proper signal integrity.

To properly connect the module's USB interface to the external application, a USB 2.0 compatible connector and cable or hardware design is required. If all connections and impedances are within the USB 2.0 specification range, a USB cable can be up to 5m long. For more information on the USB related signals see also [Table 27](#). Furthermore, the USB modem driver distributed with ALS3-US R4 needs to be installed.

¹ The specification is ready for download on http://www.usb.org/developers/docs/usb20_docs/

3.6.1. Reducing Power Consumption

While a USB connection is active, the module will never switch into SLEEP mode. Only if the USB interface is in Suspended state or Detached (i.e., VUSB_IN = 0) is the module able to switch into SLEEP mode thereby saving power¹. There are two possibilities to enable power reduction mechanisms:

› **Recommended implementation of USB Suspend/Resume/Remote Wakeup:**

The USB host should be able to bring its USB interface into the Suspended state as described in the “Universal Serial Bus Specification Revision 2.0”². For this functionality to work, the VUSB_IN line should always be kept enabled. On incoming calls and other events ALS3-US R4 will then generate a Remote Wakeup request to resume the USB host controller.

See also [4] (USB Specification Revision 2.0, Section 10.2.7, p.282):

"If USB System wishes to place the bus in the Suspended state, it commands the Host Controller to stop all bus traffic, including SOFs. This causes all USB devices to enter the Suspended state. In this state, the USB System may enable the Host Controller to respond to bus wakeup events. This allows the Host Controller to respond to bus wakeup signaling to restart the host system."

› **Implementation for (legacy) USB applications not supporting USB Suspend/Resume:**

As an alternative to the regular USB suspend and resume mechanism it is possible to employ a remote wakeup line (e.g., the RING0 line) to wake up the host application in case of incoming calls or events signaled by URCs while the USB interface is in Detached state (i.e., VUSB_IN = 0). Every wakeup event will force a new USB enumeration. Therefore, the external application has to carefully consider the enumeration timings to avoid losing any signaled events. For details on this remote wakeup functionality see [Section 3.13.3.](#)

It is possible to prevent existing data connections from being disconnected while the USB interface is in detached state (i.e., VUSB_IN=0) by configuring at least one of the module's USB ports to contribute to a host wakeup, i.e., configuring the port to try to wake up a connected host in case an appropriate event occurs (see [1]: AT^SCFG="RemoteWakeUp/Ports"), and by configuring a GPIO as USB wakeup GPIO (see [1]: AT^SCFG="RemoteWakeUp/Event/USB").

¹ Please note that if the USB interface is employed, and a USB cable is connected, there should also be a terminal program linked to the USB port in order to receive and process the initial SYSSTART URC after module startup. Otherwise, the SYSSTART URC remains pending in the USB driver's output buffer and this unprocessed data prevents the module from power saving.

² The specification is ready for download on http://www.usb.org/developers/docs/usb20_docs/

3.7. Serial Interface ASC0

ALS3-US R4 offers an 8-wire unbalanced, asynchronous modem interface ASC0 conforming to ITU-T V.24 protocol DCE signaling. The electrical characteristics do not comply with ITU-T V.28. The significant levels are 0V (for low data bit or active state) and 1.8V (for high data bit or inactive state). For electrical characteristics please refer to [Table 27](#).

ALS3-US R4 is designed for use as a DCE. Based on the conventions for DCE-DTE connections it communicates with the customer application (DTE) using the following signals:

- › Port TXD @ application sends data to the module's TXD0 signal line
- › Port RXD @ application receives data from the module's RXD0 signal line

Figure 15: Serial interface ASC0

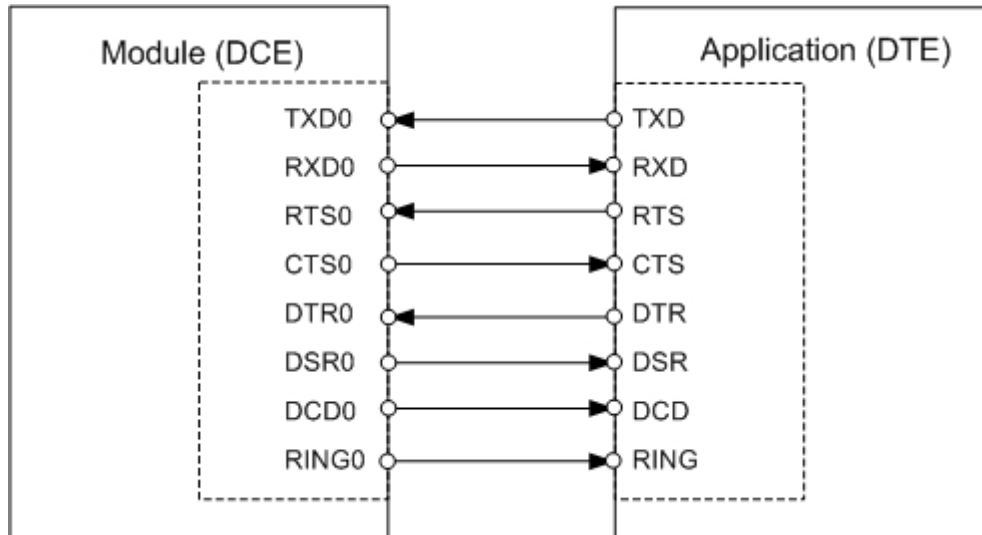

Features:

- › Includes the data lines TXD0 and RXD0, the status lines RTS0 and CTS0 and, in addition, the modem control lines DTR0, DSR0, DCD0 and RING0.
- › The RING0 signal serves to indicate incoming calls and other types of URCs (Unsolicited Result Code). It can also be configured to send pulses to the host application, for example to remotely wake up the application from power saving state. See [Section 3.13.3](#) and [\[1\]](#) for details on how to configure the RING0 line by AT^SCFG.
- › Configured for 8 data bits, no parity and 1 stop bit.
- › ASC0 can be operated at fixed bit rates from 115200bps up to 921600bps.
- › Supports RTS0/CTS0 hardware flow control.
- › Wake up from SLEEP mode by RTS0 activation (high to low transition; see [Section 3.4.4](#)).

Note: If the ASC0 serial interface is the application's only interface, it is suggested to connect test points on the USB signal lines as a potential tracing possibility.

Table 10: DCE-DTE wiring of ASC0

V.24 circuit	DCE		DTE	
	Line function	Signal direction	Line function	Signal direction
103	TXD0	Input	TXD	Output
104	RXD0	Output	RXD	Input
105	RTS0	Input	RTS	Output
106	CTS0	Output	CTS	Input
108/2	DTR0	Input	DTR	Output
107	DSR0	Output	DSR	Input
109	DCD0	Output	DCD	Input
125	RING0	Output	RING	Input

3.8. UICC/SIM/USIM Interface

ALS3-US R4 has two integrated UICC/SIM/USIM interfaces compatible with the 3GPP 31.102 and ETSI 102 221. These are wired to the host interface in order to be connected to an external SIM card holder. Five pads on the SMT application interface are reserved for each of the SIM two interfaces. An AT command allows to enable either the first or the second SIM interface (for details see [1]: AT^SCFG="Sim/CS").

The UICC/SIM/USIM interfaces support 3V and 1.8V SIM cards. Please refer to [Table 27](#) for electrical specifications of the UICC/SIM/USIM interface lines depending on whether a 3V or 1.8V SIM card is used.

The CCINx signal serves to detect whether a tray (with SIM card) is present in the card holder. Using the CCINx signal is mandatory for compliance with the GSM 11.11 recommendation if the mechanical design of the host application allows the user to remove the SIM card during operation. To take advantage of this feature, an appropriate SIM card detect switch is required on the card holder. For example, this is true for the model supplied by Molex, which has been tested to operate with ALS3-US R4 and is part of the Kontron reference equipment submitted for type approval. See [Chapter 10/](#) for Molex ordering numbers.

Table 11: Signals of the SIM interface (SMT application interface)

Signal	Description
GND	Ground connection for SIM interfaces. Optionally a separate SIM ground line using e.g., pad N11 may be used to improve EMC.
CCCLK1 CCCLK2	Chipcard clock lines for 1 st and 2 nd SIM interface.
CCVCC1 CCVCC2	SIM supply voltage lines for 1 st and 2 nd SIM interface.
CCIO1 CCIO2	Serial data lines for 1 st and 2 nd SIM interface, input and output.
CCRST1 CCRST2	Chipcard reset lines for 1 st and 2 nd SIM interface.
CCIN1 CCIN2	<p>Input on the baseband processor for detecting a SIM card tray in the holder. If the SIM is removed during operation the SIM interface is shut down immediately to prevent destruction of the SIM. The CCINx signal is active low.</p> <p>The CCINx signal is mandatory for applications that allow the user to remove the SIM card during operation.</p> <p>The CCINx signal is solely intended for use with a SIM card. It must not be used for any other purposes. Failure to comply with this requirement may invalidate the type approval of ALS3-US R4.</p>

Note: No guarantee can be given, nor any liability accepted, if loss of data is encountered after removing the SIM card during operation. Also, no guarantee can be given for properly initializing any SIM card that the user inserts after having removed the SIM card during operation. In this case, the application must restart ALS3-US R4.

Figure 16: First UICC/SIM/USIM interface

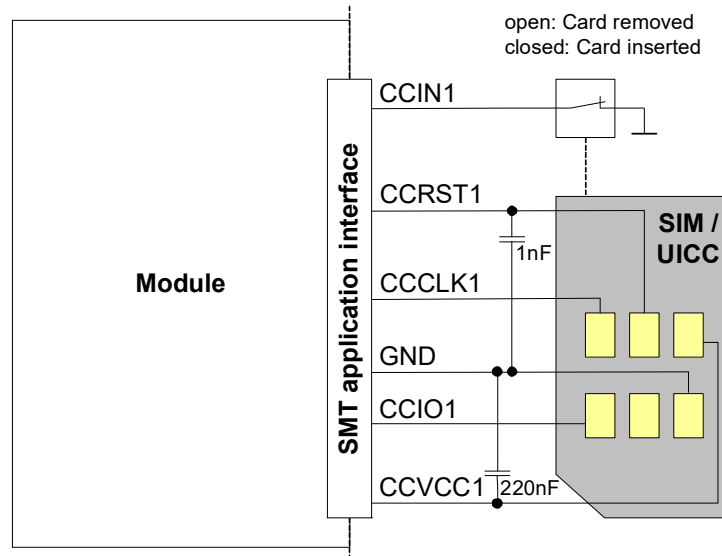

The total cable length between the SMT application interface pads on ALS3-US R4 and the pads of the external SIM card holder must not exceed 100mm in order to meet the specifications of 3GPP TS 51.010-1 and to satisfy the requirements of EMC compliance.

To avoid possible cross-talk from the CCCLKx signal to the CCIOx signal be careful that both lines are not placed closely next to each other. A useful approach is using the GND line to shield the CCIOx line from the CCCLKx line.

An example for an optimized ESD protection for the SIM interface is shown in [Section 3.8.1..](#)

Note: [Figure 16](#) shows how to connect a SIM card holder to the first SIM interface. With the second SIM interface some internally integrated components on the SIM circuit will have to be externally integrated as shown for the second SIM interface in [Figure 17](#).

Figure 17: Second UICC/SIM/USIM interface

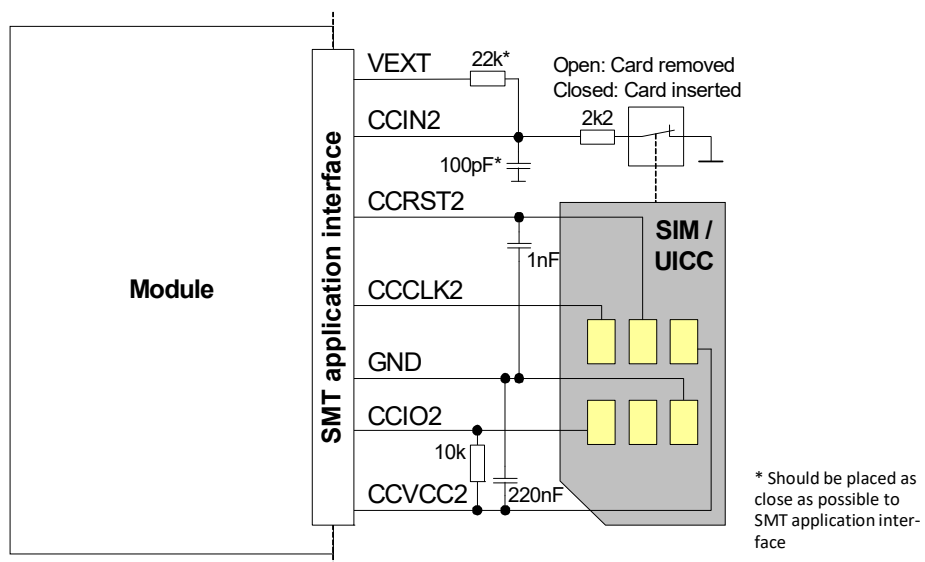

* Should be placed as close as possible to SMT application interface

3.8.1. Enhanced ESD Protection for SIM Interface

To optimize ESD protection for the SIM interfaces it is possible to add ESD diodes to the interface lines of the first and second SIM interface as shown in the example given in [Figure 18](#).

The example was designed to meet ESD protection according ETSI EN 301 489-1/7: Contact discharge: $\pm 4\text{kV}$, air discharge: $\pm 8\text{kV}$.

Figure 18: SIM interface - enhanced ESD protection

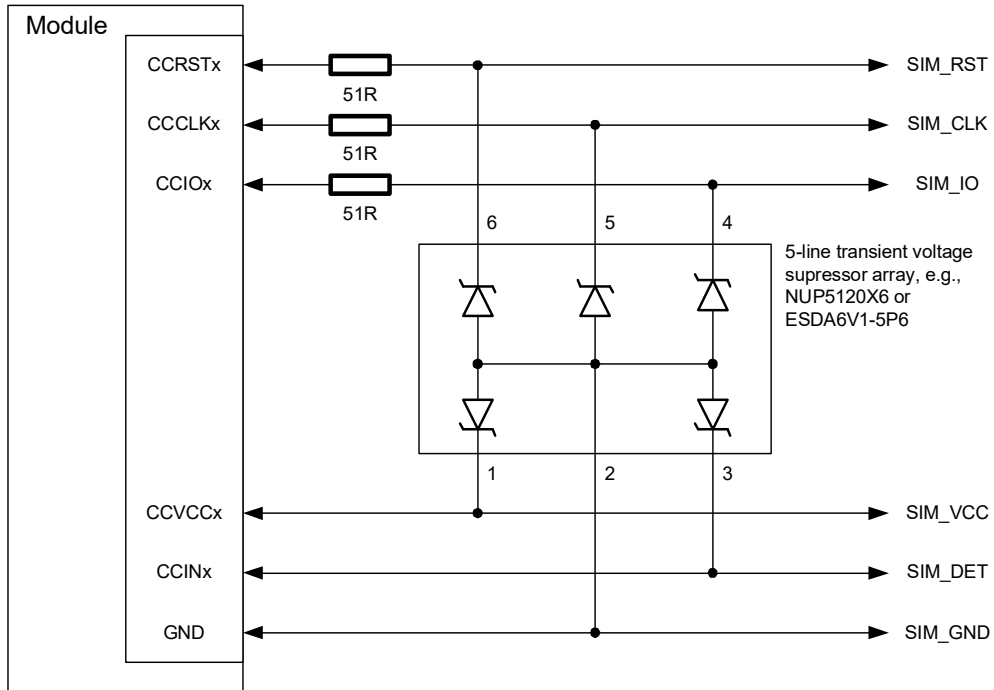

3.9. Analog Audio Interface

ALS3-US R4 has an analog audio interface with a balanced analog microphone input and a balanced analog earpiece output. A supply voltage and an analog ground connection are provided at dedicated pads.

ALS3-US R4 offers six audio modes which can be selected with the AT^SNFS command. The electrical characteristics of the voiceband part vary with the audio mode. For example, sending and receiving amplification, sidetone paths, noise suppression etc. depend on the selected mode and can be altered with AT commands (except for mode 1).

Please refer to [Section 6.7](#) for specifications of the audio interface and an overview of the audio parameters. Detailed instructions on using AT commands are presented in [\[1\]](#). [Table 31](#) summarizes the characteristics of the various audio modes and shows what parameters are supported in each mode.

When shipped from factory, all audio parameters of ALS3-US R4 are set to audio mode 1. This is the default configuration optimized for the Votronic HH-SI-30.3/V1.1/0 handset and used for type approving the Kontron reference configuration.

3.9.1. Microphone Inputs and Supply

The differential microphone inputs MICP and MICN present variable impedances depending on the gain. The microphone inputs must be decoupled by capacitors C_k (typical $1\mu\text{F}$). The input stage uses a differential programmable gain amplifier (PGA) circuit. The detailed structure of this stage and the following uplink path is shown in Figure 19. The input can be controlled by the AT command `AT^SNFI`. Command parameters with their effect are mentioned in the figure and marked in <red>. More information about audio AT commands can be found in Section 6.7. and [1].

Figure 19: Structure of audio input and supply

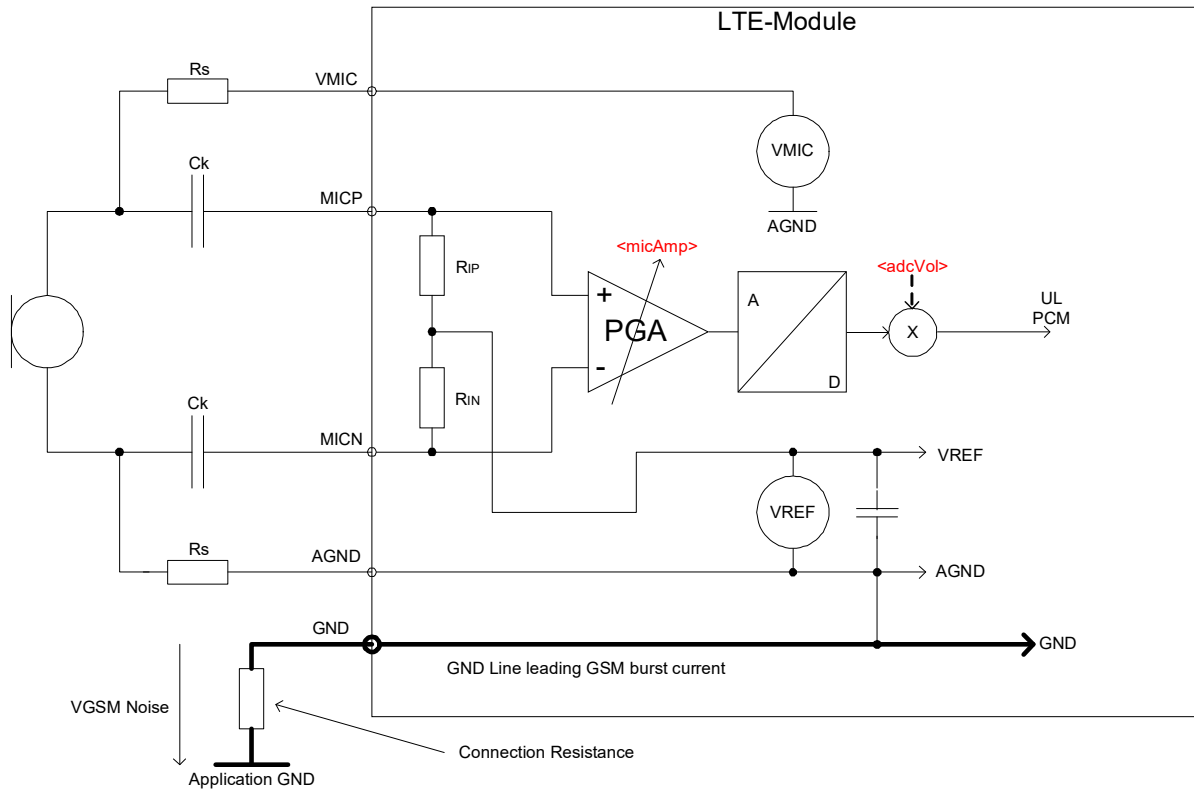

MICP leads the signal to the non-inverting input of the PGA while the inverted signal goes through MICN to the inverting input of the PGA. The gain of the input stage can be programmed by the parameter `<micAmp>` in steps of 0.75dB between -12dB and +35.25dB. R_{iP} respective R_{iN} represent the variable input resistances depending on PGA gain. Typical values of R_{iP} or R_{iN} are shown in Table 12 for some selected gains.

Table 12: Input resistor values versus input gain

Gain [dB]	R_{iP} [k Ω]	R_{iN} [k Ω]
35.25	4.2	18.4
30	6.8	18.4
18	11.0	18.4
12	14.0	18.4
6	16.2	18.4
0	18.3	18.4
-12	19.0	18.4

After the analogue digital conversion the uplink gain can be scaled in the onboard codec by `<adcVol>` in the range of -71.625dB and +23.625dB in steps of 0.375dB.

It is strongly recommended to use the AGND line for grounding the microphone circuit. AGND provides for the same module ground potential the analog circuits of the module refer to. AGND must not be connected to the system GND anywhere. Otherwise high GSM burst peak currents will flow across AGND causing GSM humming in the uplink audio signal.

A regulated power supply for electret microphones is available at VMIC. The voltage at VMIC is rated at 2.4V at 3mA and is available while audio is active (e.g., during a call).

The following figures show possible microphone and line connections.

Figure 20: Single ended microphone connection

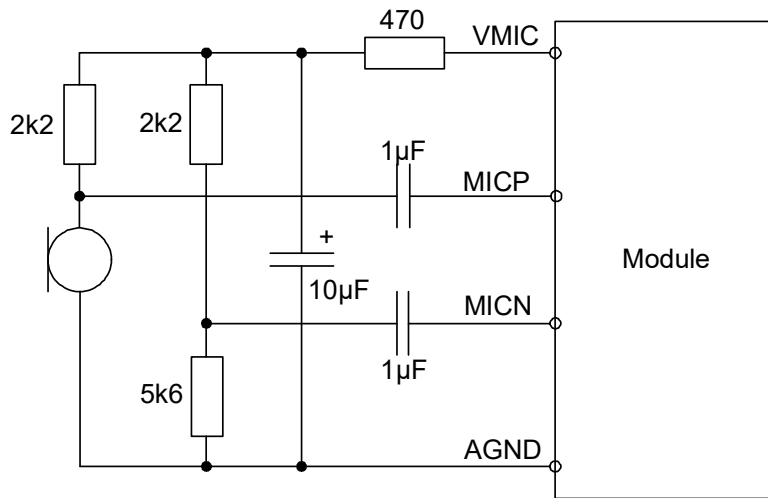

The configuration shown in [Figure 20](#) is suitable for short distances between microphone and module. A typical electret microphone has a metal case connected to its ground pad. Since this is routed directly to AGND, electro static discharges applied to the microphone will be easily led away. It is recommended to use an additional RC-filter for VMIC (for example 470Ω and 10μF as shown in the figure) in case a high microphone gain is necessary.

If the microphone lines are longer, use the configuration shown in [Figure 21](#). It is recommended to use an additional RC-filter for VMIC (for example 1kΩ, 10μF and 1kΩ as shown in the figure) in case a high microphone gain is necessary.

Figure 21: Differential microphone connection

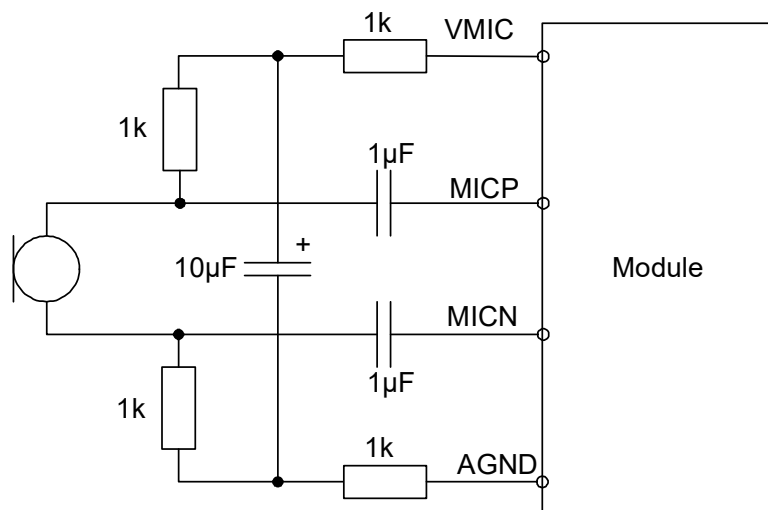
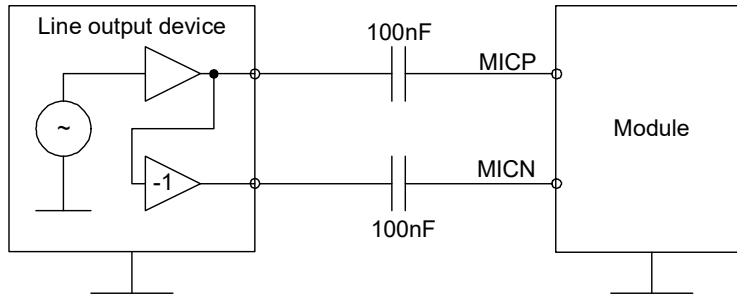

Figure 22: Line input



Using the line input configuration the output level of the ground related balanced source should be as high as possible to achieve the best SNR. Since the input impedance of ALS3-US R4 is quite high at low gains, the coupling capacitances may be smaller.

3.9.2. Loudspeaker Output

ALS3-US R4 provides a differential loudspeaker output EPP/EPN. If it is used as line output, the application should provide a capacitor decoupled differential input to eliminate GSM humming. A single ended connection to a speaker or a line input is not recommended.

The following figures show the typical output configurations.

Figure 23: Differential loudspeaker connection

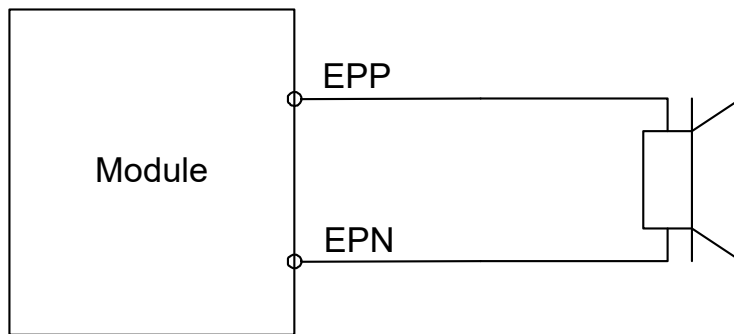
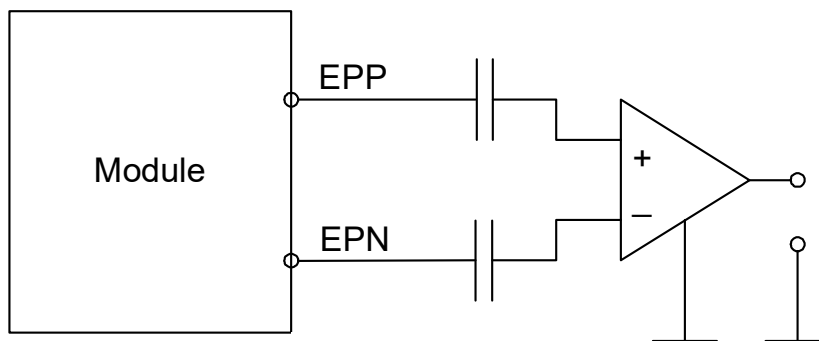

Figure 24: Line output connection



3.10. Digital Audio Interface

ALS3-US R4 supports a digital audio interface that can be employed either as pulse code modulation interface (see [Section 3.10.1.](#)) or as inter IC sound interface (see [Section 3.10.2.](#)). Operation of these interface variants is mutually exclusive, and can be configured by AT command (see [\[1\]](#)). Default setting is pulse code modulation.

3.10.1. Pulse Code Modulation Interface (PCM)

ALS3-US R4's PCM interface can be used to connect audio devices capable of pulse code modulation. The PCM functionality covers the use of narrowband codecs with 8kHz sample rate and wideband codecs with 16kHz sample rate as well. Configured for wideband the PCM interface runs at 16 kHz sample rate (62.5µs frame length), while the signal processing maintains this rate in a wideband AMR call or samples automatically down to 8kHz in a narrowband call. Therefore, the PCM sample rate is independent of the audio bandwidth of the call.

The PCM interface has the following implementation:

- › Master mode, slave mode
- › Short frame synchronization, long frame synchronization
- › 8kHz and 16kHz sample rate
- › 128kHz, 256kHz, 512kHz, 2048kHz bit clock at 8kHz sample rate
- › 256kHz, 512kHz, 1024kHz, 4096kHz bit clock at 16kHz sample rate
- › Permanent clock option

For the PCM interface configuration the parameters <clock>, <mode>, <frame_mode>, <ext_clk_mode> and <sample_rate> of the AT^SAIC command can be configured in any combination (for details on AT^SAIC see [\[1\]](#)). But the following hints should be considered while configuring the PCM interface:

The external clock mode should be switched off in slave mode.

In Slave Mode <clock>, <frame_mode> and <sample_rate> must be set according to the characteristics of the external master. There is no automatic detection of the received clock frequency, frame length and sample rate.

[Table 13](#) lists the available PCM interface signals.

Table 13: Overview of PCM pin functions

Signal name on SMT application interface	Signal configuration inactive	Signal direction: Master	Signal direction: Slave	Description
DOUT	PD	O	O	PCM data from ALS3-US R4 to external codec
DIN	PD	I	I	PCM data from external codec to ALS3-US R4
FSC	PD	O	I	Frame synchronization signal to/from external codec
BCLK	PD	O	I	Bit clock to/from external codec

Note: PCM data is always formatted as 16-bit uncompressed two's complement. Also, all PCM data and frame synchronization signals are written to the PCM bus on the rising clock edge and read on the falling edge.

The timing of a PCM short frame is shown in [Figure 25](#).

Figure 25: PCM timing short frame (master, 4096KHz, 16kHz sample rate)

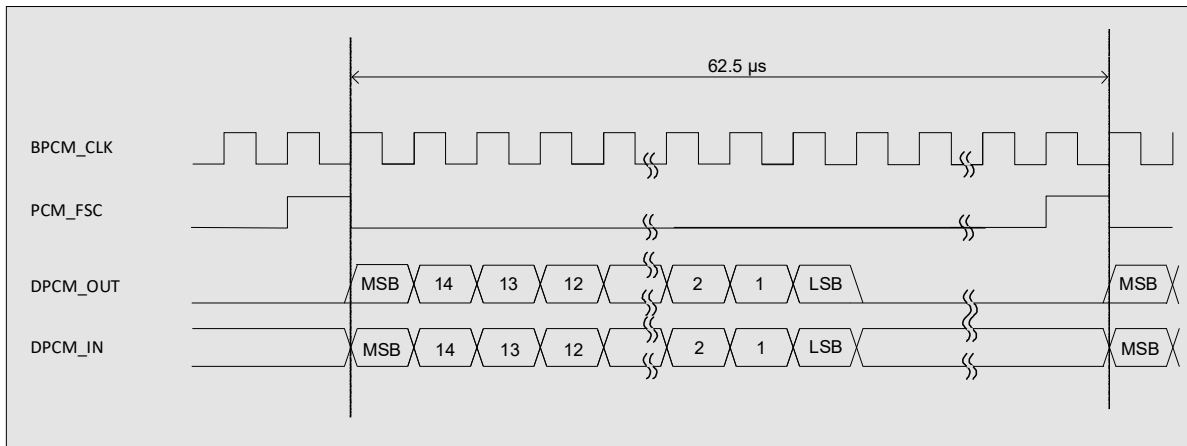

Configured to short frame synchronization, the pulse on FSC is one clock period wide and occurs one clock before the data, using long frame the pulse has a duty cycle of 50% starting with the first data bit.

The timing of a PCM long frame is shown in [Figure 26](#).

Figure 26: PCM timing long frame (master, 128kHz, 8kHz sample rate)

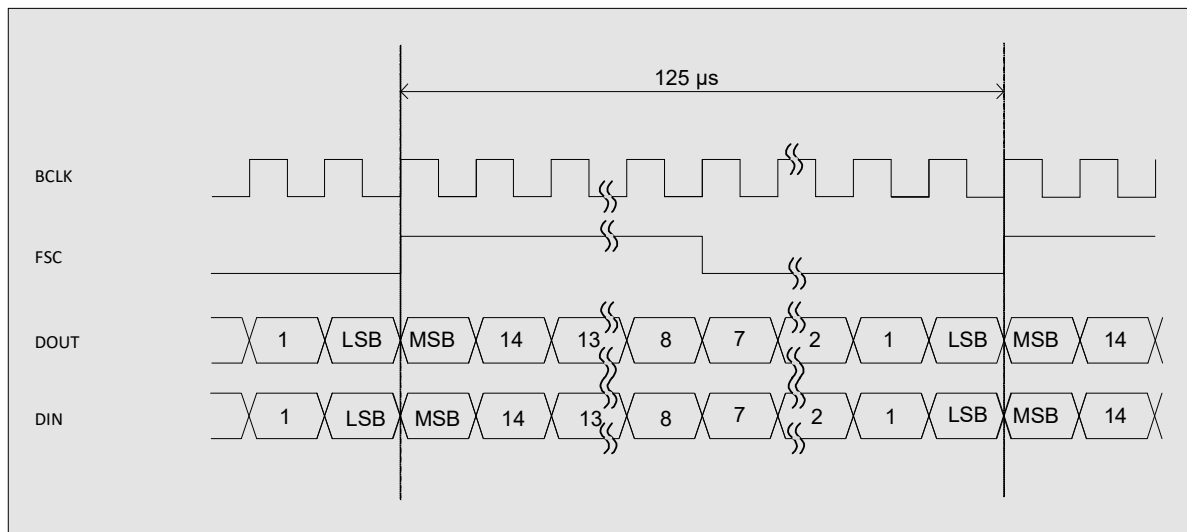

Characteristics of Audio Modes

ALS3-US R4 has various audio modes selectable with AT^SNFS (for details on AT^SNFS see [\[1\]](#)).

Audio mode 1 with its default settings is used for type approval with the Votronic handset via the DSB75 codec adapter. The handset is adjusted for the type 3.2 low-leakage ear simulator for narrowband and wideband calls.

Audio mode 6 is used for transparent access to the narrowband or wideband speech coders without any signal processing (except for sample rate converters in case of narrowband calls). The full scale level of the PCM interface is mapped to the full scale level of the speech coders.

3.10.2. Inter IC Sound Interface (I²S)

The I²S Interface is a standardized bidirectional I²S ("Inter-IC Sound Interface") based digital audio interface for transmission of mono voice signals for telephony services.

The I²S interface can be enabled and configured using the AT command AT^SAIC (see [1]). An activation is possible only out of call and out of tone presentation. The I²S properties and capabilities comply with the requirements laid out in the Phillips I2S Bus Specifications, revised June 5, 1996.

The I²S interface has the following characteristics:

- › Bit clock mode: Master, optional master clock output
- › Sampling rate: 8KHz (narrowband), 16KHz (wideband)
- › 256kHz bit clock at 8kHz sample rate
- › 512kHz bit clock at 16kHz sample rate
- › Frame length: 32 bit stereo voice signal (16 bit word length)
- › Optional Master clock: 2048KHz (8KHz sample rate) or 4096KHz (16KHz sample rate)

The digital audio interface pads available for the PCM interface are also available for the I²S interface. In I²S mode they have the same electrical characteristics. For the master clock option there is a separate line (see Section 6.5. for more information on these lines).

Table 14 lists the available I²S interface signals, Figure 27 shows the I²S timing.

Table 14: Overview of I²S pin functions

Signal name on SMT application interface	Signal configuration inactive	Signal direction: Master	Description
DOUT	PD	O	I ² S data from ALS3-US R4 to external codec
DIN	PD	I	I ² S data from external codec to ALS3-US R4
FSC	PD	O	Frame synchronization signal to/from external codec Word alignment (WS)
BCLK	PD	O	Bit clock to external codec
MCLK	PD	O	I ² S Master clock to supply external codecs without PLL.

Figure 27: I²S timing (master mode)

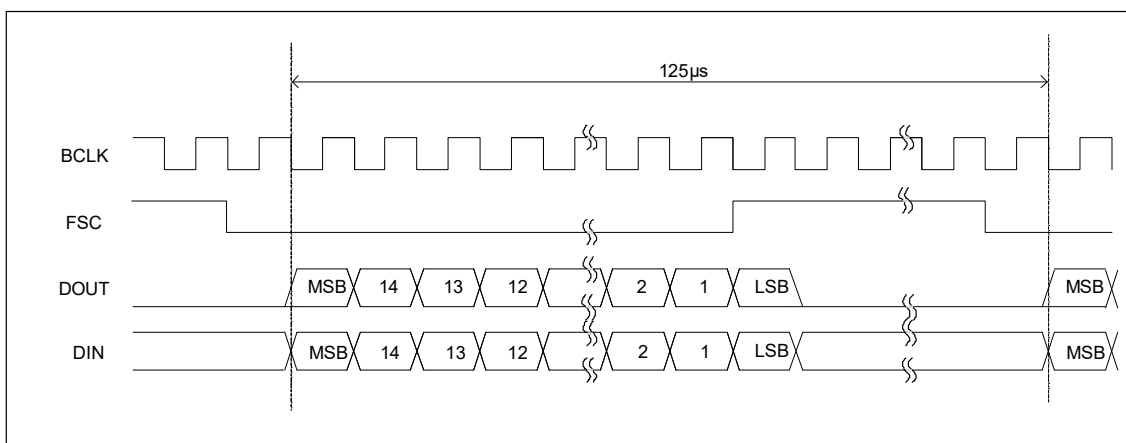

3.11. Analog-to-Digital Converter (ADC)

ALS3-US R4 provides three unbalanced ADC input lines: ADC1_IN, ADC2_IN and ADC3_IN. They can be used to measure three independent, externally connected DC voltages in the range of 0.3V to 3.075V. As described in [Section 5.1.4.](#) and [Section 5.1.4.](#) they can be used especially for antenna diagnosing.

The AT^SRADC command can be employed to select the ADC line, set the measurement mode and read out the measurement results.

3.12. GPIO Interface

ALS3-US R4 has 10 GPIOs for external hardware devices. Each GPIO can be configured for use as input or output. All settings are AT command controlled.

The IO port driver has to be open before using and configuring GPIOs. Before changing the configuration of a GPIO pin (e.g. input to output) the pin has to be closed. If the GPIO pins are not configured or the pins/driver were closed, the GPIO pins are high-Z with pull down resistor. If a GPIO is configured to input, the pin has high-Z without pull resistor.

GPIO1 can be configured as dead reckoning synchronization line (see [Chapter 4/](#)), GPIO2 can be configured as 700MHz antenna switch control signal (see [Section 3.13.6.](#)), GPIO6 may be configured as low current indicator signal (see [Section 3.13.4.](#)), and GPIOs may be set as remote host wakeup lines (see [Section 3.13.3.](#)).

If the ALS3-US R4 is in power save (SLEEP) mode a level state transition at GPIO1, GPIO3, GPIO4, GPIO5 and GPIO9 will wake up the module. To query the level state the AT^SCPOL command may be used.

3.13. Control Signals

3.13.1. PWR_IND Signal

PWR_IND notifies the on/off state of the module. For state detection an external pull-up resistor is required (cp. R1 in below [Figure 28](#)). As long as the feeding voltage is applied at the pull-up resistor, a high state of PWR_IND indicates that the module is switched off.

Figure 28: PWR_IND signal

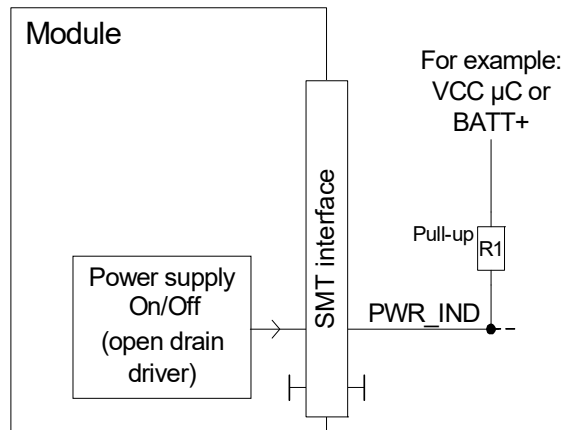

3.13.2. Behavior of the RING0 Line

The RING0 line serves to indicate incoming calls and other types of URCs (Unsolicited Result Code).

Although not mandatory for use in an external host application, it is recommended that you connect the RING0 line to an interrupt line of your application. In this case, the application can be designed to receive an interrupt when a falling edge on RING0 occurs. This solution is most effective, particularly, for waking up an application from power saving (see also [Section 3.13.3](#)). Therefore, utilizing the RING0 line provides an option to significantly reduce the overall current consumption of your application.

The RING0 line behavior and usage can be configured by AT command. For details see [\[1\]](#): AT^SCFG.

3.13.3. Remote Wakeup

If no call, data or message transfer is in progress, the external host application may shut down its own module interfaces or other components in order to save power. If a call, data, or other request (URC) arrives, the external application can be notified of this event and be woken up again by a state transition of a configurable remote wakeup line. Available as remote wakeup lines are all GPIO signals as well as the RING0 line. Please refer to [1]: AT^SCFG: "RemoteWakeup/..." for details on how to configure these lines for defined wakeup events on specified device interfaces. Possible states are listed in Table 15.

If no line is specifically configured as remote wakeup signal, the remote USB suspend and resume mechanism as specified in the "Universal Serial Bus Specification Revision 2.0"¹ applies for the USB interface (see Section 3.6.), or the RING0 line may be employed with USB applications not supporting this mechanism (see also Section 3.6.1.). This legacy behavior of the RING0 line as remote host wakeup line has to be enabled and configured by AT command (see [1]: AT^SCFG: "URC/Ringline"). Possible states are listed in Table 15.

Table 15: Host wakeup lines

Signal	I/O/P	Description
RING0	O	Inactive to active low transition: 0 = The host shall wake up 1 = No wake up request
GPIOx	O	Inactive to active high transition: 0 = No wake up request 1 = The host shall wake up

¹ The specification is ready for download on http://www.usb.org/developers/docs/usb20_docs/

3.13.4. Low Current Indicator

A low current indication is optionally available over a GPIO line. By default, low current indication is disabled and the GPIO pads can be configured and employed as usual.

For a GPIO pad to work as a low current indicator the feature has to be enabled by AT command (see [1]: AT^SCFG: MEop-Mode/PowerMgmt/LCI). By default, the GPIO6 pad is configured as LCI_IND signal.

If enabled, the GPIOx/LCI_IND signal is high when the module is sleeping. During its sleep the module will for the most part be slow clocked with 32kHz RTC.

Table 16: Low current indicator line

Signal	I/O/P	Description
GPIOx/LCI_IND	O	Inactive to active high transition: 0 = High current consumption The module draws its power via BATT+ 1 = Low current consumption (only reached during SLEEP mode) The module draws only a low current via BATT+

Figure 29: Low current indication timing (still to be confirmed)

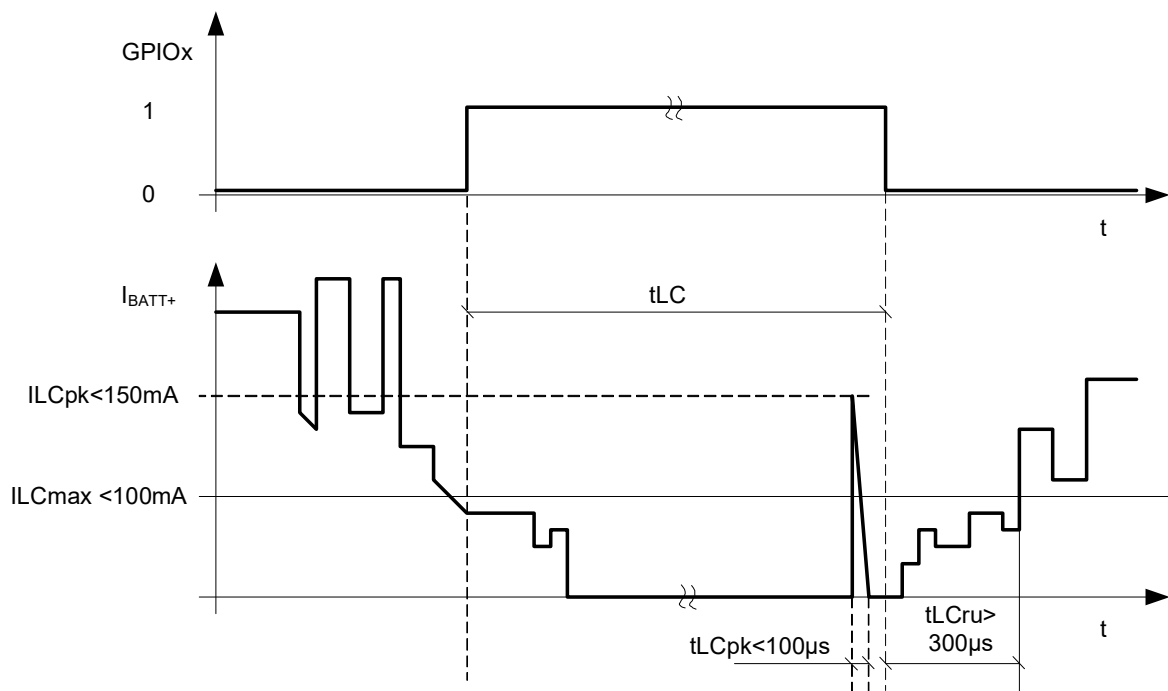

- tLC Time for the I_{BATT+} current consumption: $ILC_{max} < 100mA$.
- tLCpk Max. time duration for the inrush current peak at the end of the low current period.
- tLCru When the GPIOx signal becomes inactive (low) the current ramps up to the maximum low current value within tLCru.
- ILCpk When the module turns from sleep to normal operation some internal supply voltages will be switched on. That causes a small inrush current peak.
- ILCmax During the low current period tLC the current consumption does not exceed the ILCmax value.

3.13.5. Network Connectivity and Technology Status Signals

The STATUS line serves to indicate the module's network connectivity state or the underlying network technology (2G or 3G/4G) and can be used to control an externally connected LED as shown in Figure 30. To operate the LED a buffer, e.g. a transistor or gate, must be included in the external application.

Figure 30: LED circuit (example)

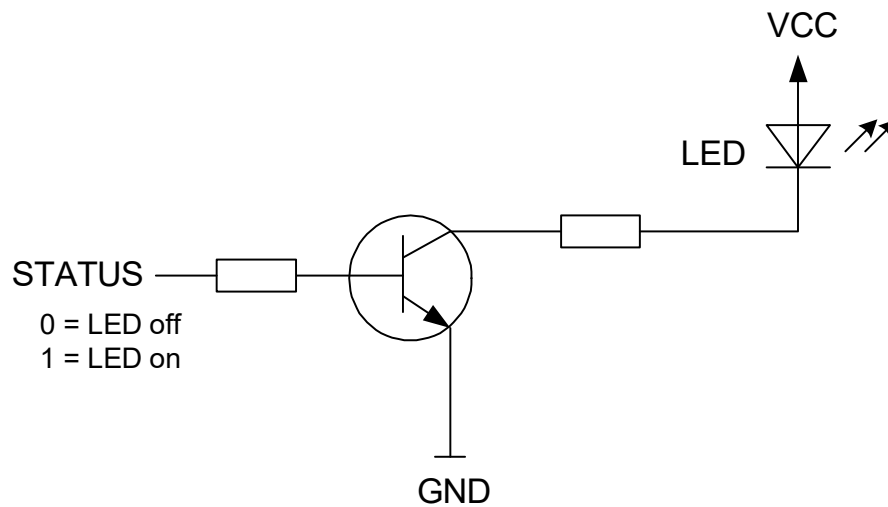

For electrical characteristics of the STATUS line see Table 27. The network connectivity and technology signal function is volatile and has to be activated after module startup with AT[^]SLED. For details on the command as well as status and mode indications through blinking intervals see [1].

3.13.6. 700MHz Antenna Switch Control

To provide for an antenna optimization over a wide frequency range, the GPIO2 (ANT_SWITCH) line can be configured as a control signal for a possible external antenna switch that is able to change between an antenna covering the 700MHz band and an antenna covering all other bands - depending on the frequency band currently being used by the module.

If the control switch functionality is enabled, GPIO2 is set to "high" (1) if the module is employing frequencies in the 700 MHz range (i.e., LTE band 17) and "low" (0) for all other frequencies, including the 800/850 MHz frequency bands.

A GPIO2 signal switch is triggered by all module internal activities involving a change of the used frequency, even if only temporary (e.g., inter-band scanning using compressed mode). The maximum delay/deviation between internal usage change of the frequency band, and the GPIO2 signal change is 10 microseconds.

For electrical characteristics of the GPIO2 (ANT_SWITCH) line see Table 27. The antenna switch control is non-volatile and has to be activated after module startup with AT[^]SCFG="GPIO/Mode/Antenna". For details on the command see [1].

4/ GNSS Receiver

ALS3-US R4 integrates a GNSS receiver that offers the full performance of GPS/GLONASS/Galileo technology. The GNSS receiver is able to continuously track all satellites in view, thus providing accurate satellite position data.

The integrated GNSS receiver supports the NMEA protocol via USB or ASC0 interface. NMEA is a combined electrical and data specification for communication between various (marine) electronic devices including GNSS receivers. It has been defined and controlled by the US based National Marine Electronics Association. For more information on the NMEA Standard please refer to <http://www.nmea.org>.

Depending on the receiver's knowledge of last position, current time and ephemeris data, the receiver's startup time (i.e., TTFF = Time-To-First-Fix) may vary: If the receiver has no knowledge of its last position or time, a startup takes considerably longer than if the receiver has still knowledge of its last position, time and almanac or has still access to valid ephemeris data and the precise time. For more information see [Section 6.9](#).

By default, the GNSS receiver is switched off. It has to be switched on and configured using AT commands. For more information on how to control the GNSS interface via the AT commands see [\[1\]](#).

Dead Reckoning Sync Line:

Dead reckoning solutions are used in (automotive) platforms to determine the (vehicles) location even when there is no GPS signal available (e.g. in tunnels, basement garages or even between high buildings in cities).

In addition to dead reckoning related NMEA sentences (for details see [\[1\]](#): GNSS sentences), ALS3-US R4 provides a dead reckoning synchronization line (DR_SYNC line) to be employed in external dead reckoning applications. DR_SYNC is derived from the GPS signal clock as 1 pulse per second (1PPS) signal, with a frequency of 1Hz, an accuracy of +/-5 ms, and a high state pulse of 1ms. The DR_SYNC signal is provided as long as synchronized with the GPS satellite clock, and continues after GPS signal loss. DR_SYNC can be configured for the GPIO1 pad.

DR_SYNC can be activated using the AT command AT^SGPSC. For more information on the command please refer to [\[1\]](#), for electrical characteristics see [Table 27](#).

5/ Antenna Interfaces

5.1. GSM/UMTS/LTE Antenna Interface

The ALS3-US R4 GSM/UMTS/LTE antenna interface comprises a GSM/UMTS/LTE main antenna as well as a UMTS/LTE Rx diversity/MIMO antenna to improve signal reliability and quality¹. The interface has an impedance of 50Ω. ALS3-US R4 is capable of sustaining a total mismatch at the antenna interface without any damage, even when transmitting at maximum RF power.

The external antennas must be matched properly to achieve best performance regarding radiated power, modulation accuracy and harmonic suppression. Matching networks are not included on the ALS3-US R4 PCB and should be placed in the host application, if the antenna does not have an impedance of 50Ω.

Regarding the return loss ALS3-US R4 provides the following values in the active band:

Table 17: Return loss in the active band

State of module	Return loss of module	Recommended return loss of application
Receive	≥ 8dB	≥ 12dB
Transmit	not applicable	≥ 12dB
Idle	≤ 5dB	not applicable

¹ By delivery default the UMTS/LTE Rx diversity/MIMO antenna is configured as available for the module since its usage is mandatory for LTE. Please refer to [1] for details on how to configure antenna settings.

5.1.1. Antenna Installation

The antenna is connected by soldering the antenna pads (ANT_MAIN; ANT_DRX_MIMO) and their neighboring ground pads directly to the application’s PCB.

Figure 31: Antenna pads (bottom view)

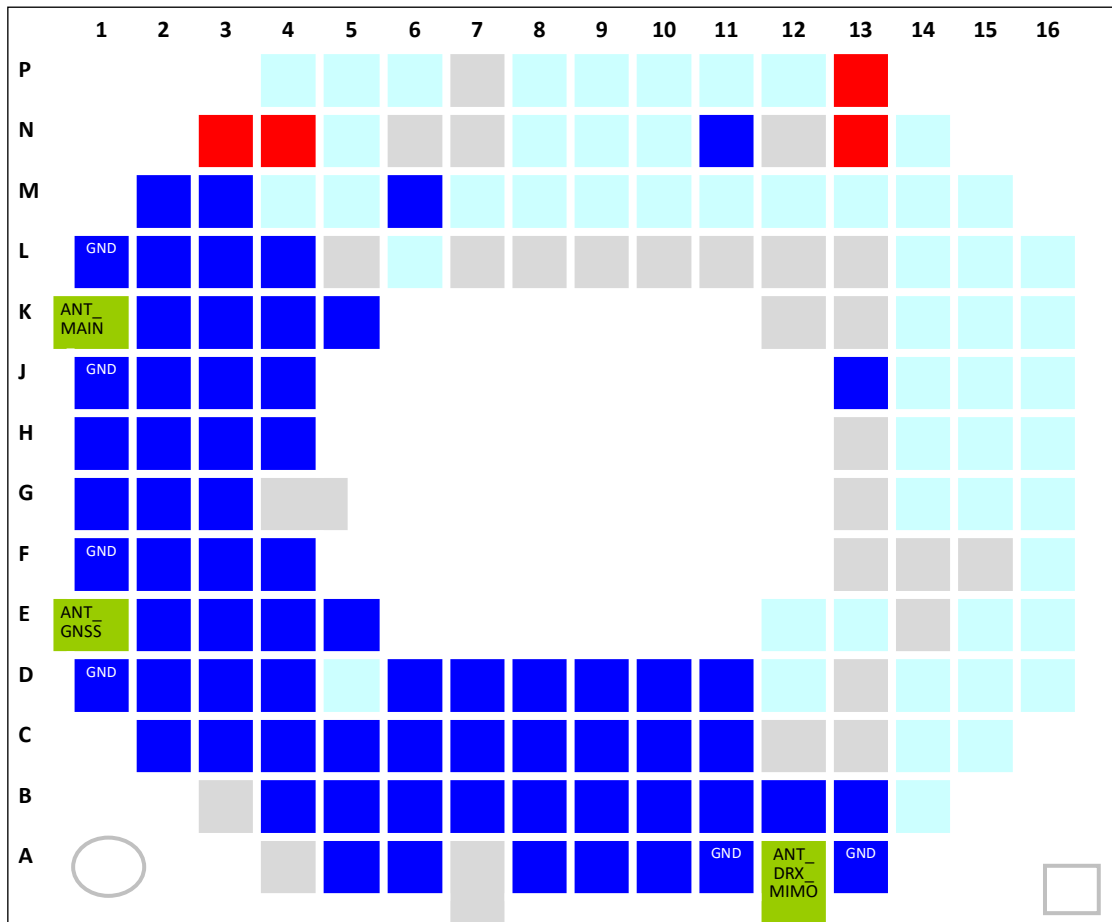

The distance between the antenna pads and their neighboring GND pads has been optimized for best possible impedance. To prevent mismatch, special attention should be paid to these pads on the application’ PCB.

The wiring of the antenna connection, starting from the antenna pad to the application’s antenna should result in a 50Ω line impedance. Line width and distance to the GND plane need to be optimized with regard to the PCB’s layer stack. Some examples are given in Section 5.1.2..

To prevent receiver desensitization due to interferences generated by fast transients like high speed clocks on the external application PCB, it is recommended to realize the antenna connection line using embedded Stripline rather than Micro-Stripline technology. Please see Section 5.1.2. for examples of how to design the antenna connection in order to achieve the required 50Ω line impedance.

For type approval purposes, the use of a 50Ω coaxial antenna connector (U.FL-R-SMT) might be necessary. In this case the U.FL-R-SMT connector should be placed as close as possible to ALS3-US R4’s antenna pad.

5.1.2. RF Line Routing Design

5.1.2.1. Line Arrangement Examples

Several dedicated tools are available to calculate line arrangements for specific applications and PCB materials - for example from <http://www.polarinstruments.com/> (commercial software) or from <http://web.awrcorp.com/Usa/Products/Optional-Products/TX-Line/> (free software).

Embedded Stripline

This below figure shows line arrangement examples for embedded stripline.

Figure 32: Embedded Stripline line arrangement

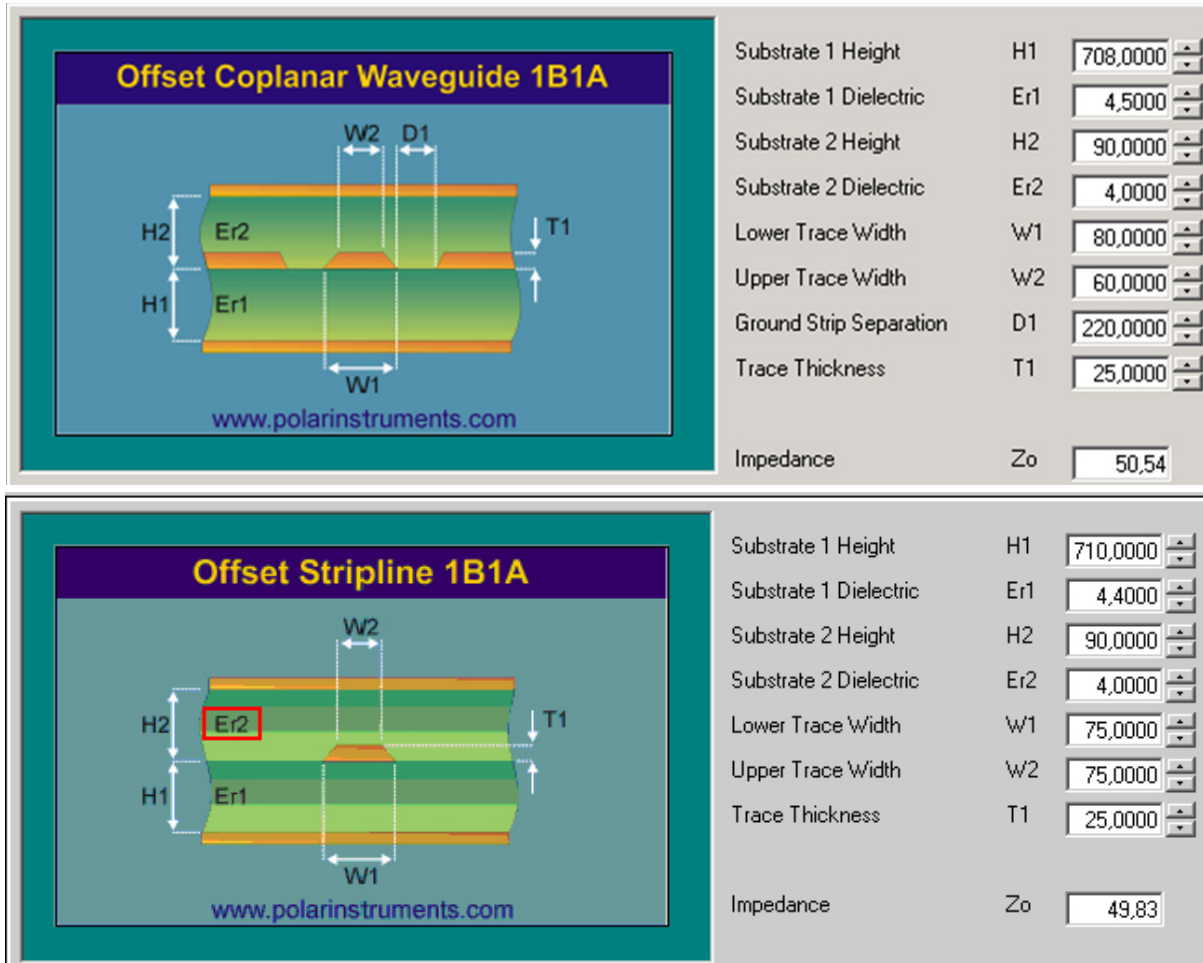

Micro-Stripline

This section gives two line arrangement examples for micro-stripline.

Figure 33: Micro-Stripline line arrangement samples

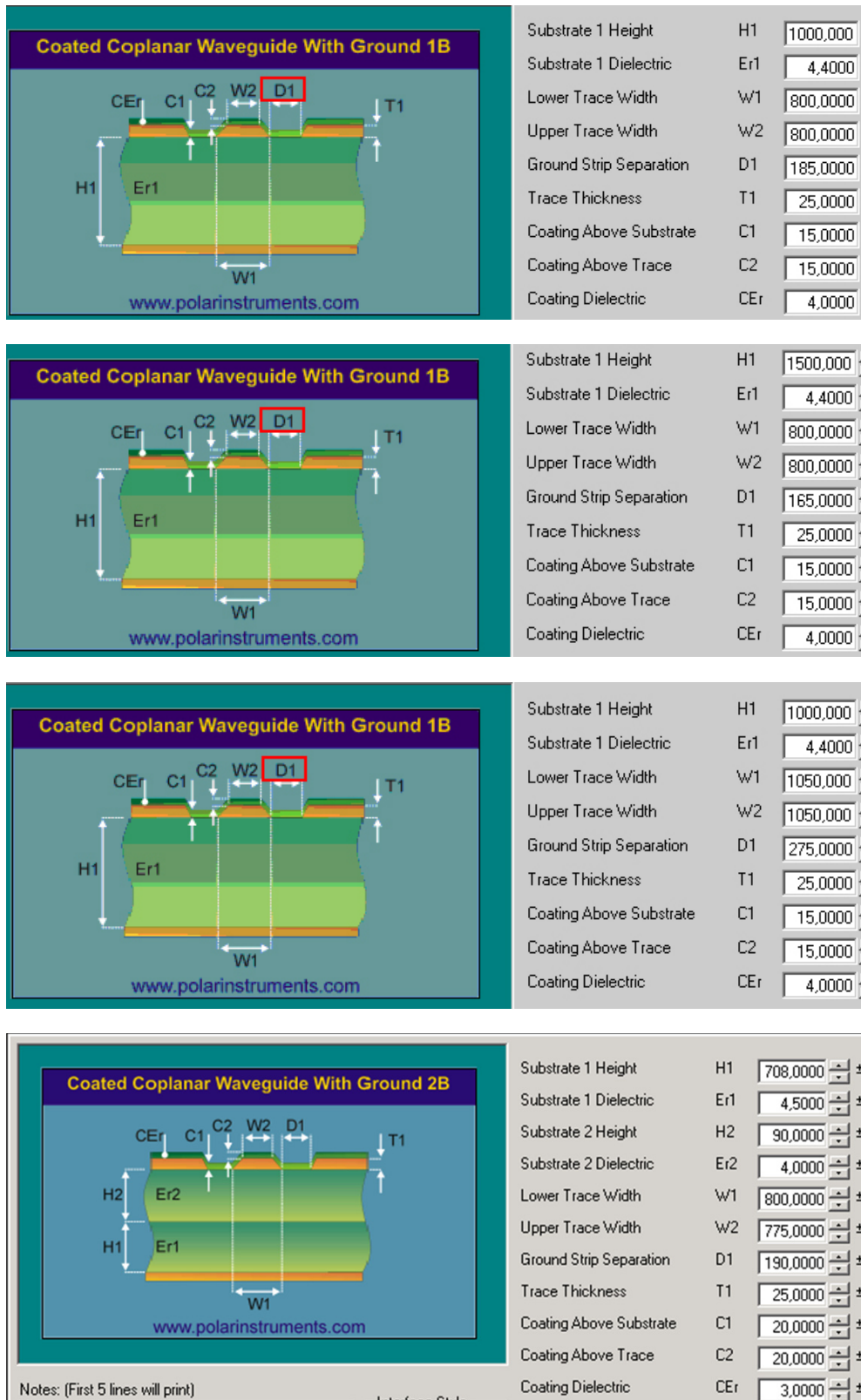

5.1.2.2. Routing Example

Interface to RF Connector

Figure 34 shows a sample connection of a module’s antenna pad at the bottom layer of the module PCB with an application PCB’s coaxial antenna connector. Line impedance depends on line width, but also on other PCB characteristics like

dielectric, height and layer gap. The sample stripline width of 0.33mm is recommended for an application with a PCB layer stack resembling the one of the ALS3-US R4 evaluation board shown in Figure 35. For different layer stacks the stripline width will have to be adapted accordingly.

Figure 34: Routing to application's RF connector

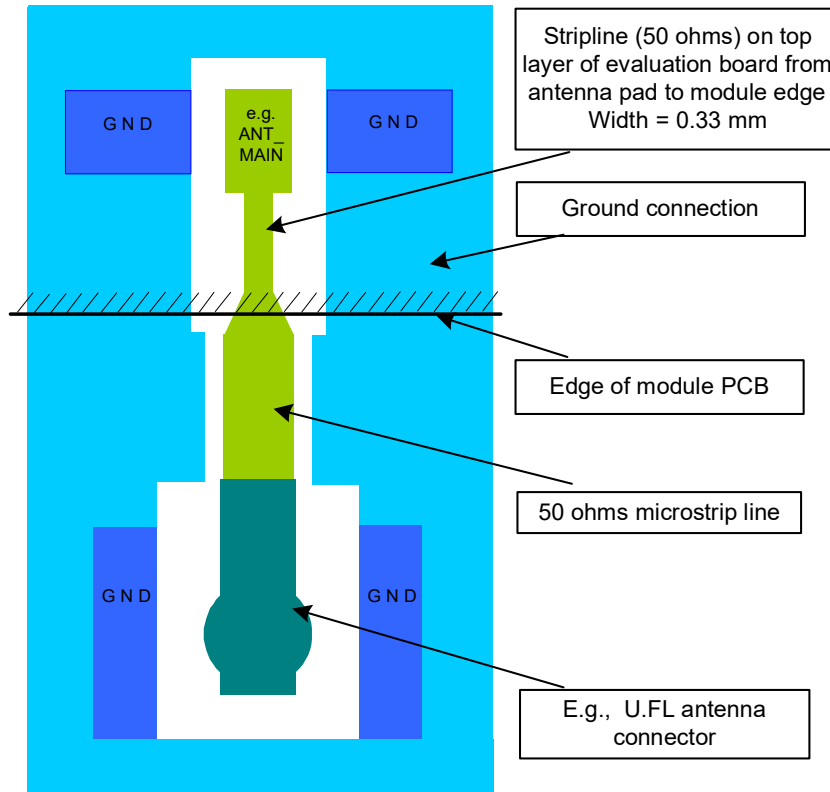

Figure 35: ALS3-US R4 evaluation board layer table

Layer No.	Construction	Finished thkness (um)
s/m		15
1		25
	Prepreg :1080X1 RC:64%	65
2		25
	CORE:28mil H/Hoz 7628x4	708
3		25
	Prepreg :1080X1 RC:64%	65
4		25
s/m		15
Total thickness (including S/M):		968

5.1.3. ESD Protection for Antenna Interfaces

The following [Figure 36](#) shows how to implement an external ESD protection for the RF antenna interfaces (ANT_MAIN and ANT_DRX_MIMO) with either a T pad or PI pad network circuit (for RF line routing design see also [Section 5.1.2.](#)).

Figure 36: ESD protection for RF antenna interface

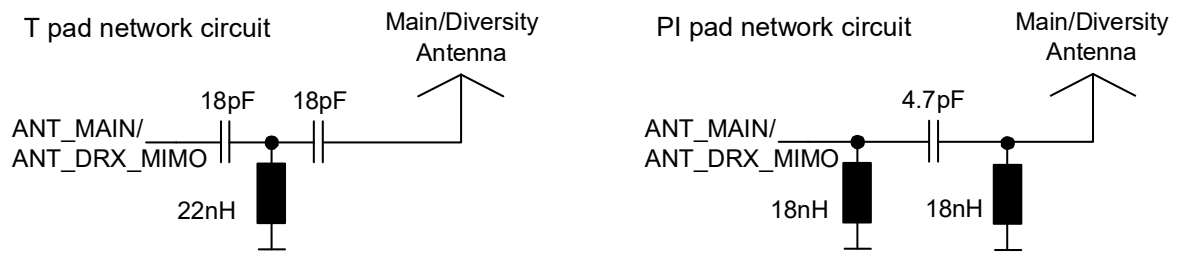

Recommended for the above sample circuits is the use of SMD 0402 chip components, e.g., Size 0402 SMD inductors from the Panasonic ELJRF series (22nH and 18nH inductors) or Murata LQW15AN18NJ00 (18nH inductors only).

5.1.4. RF Antenna Diagnostic

RF antenna (GSM/UMTS/LTE) diagnosis requires the implementation of an external antenna detection circuit. An example for such a circuit is illustrated in [Figure 38](#). It allows to check the presence and the connection status of 1 or 2 RF antennas.

To properly detect the antenna and verify its connection status the antenna feed point must have a DC resistance R_{ANT} of $9k\Omega (\pm 3k\Omega)$.

A positive or negative voltage drop (referred to as $V_{disturb}$) on the ground line may occur without having any impact on the measuring procedure and the measuring result. A peak deviation ($V_{disturb}$) of $\leq 0.8V$ from ground is acceptable.

$V_{disturb}$ (peak) = $\pm 0.8V$ (maximum); $f_{disturb}$ = 0Hz ... 5kHz

Waveform: DC, sinus, square-pulse, peak-pulse (width = 100 μ s)

$R_{disturb}$ = 5 Ω

To make sure that the antenna detection operates reliably, the capacitance at the module's antenna pad (i.e., the cable capacitance plus the antenna capacitance (C_{ANT})) should not be greater than 100pF. Some types of antennas (for example "inverted F antenna" or "half loop antenna") need an RF short circuit between the antenna structure and ground to work properly. In this case the RF short circuit has to be realized via a capacitance (C_{ANT}). For C_{ANT} we recommend a capacitance lower than 100pF (see [Figure 37](#)).

Figure 37: Resistor measurement used for antenna detection

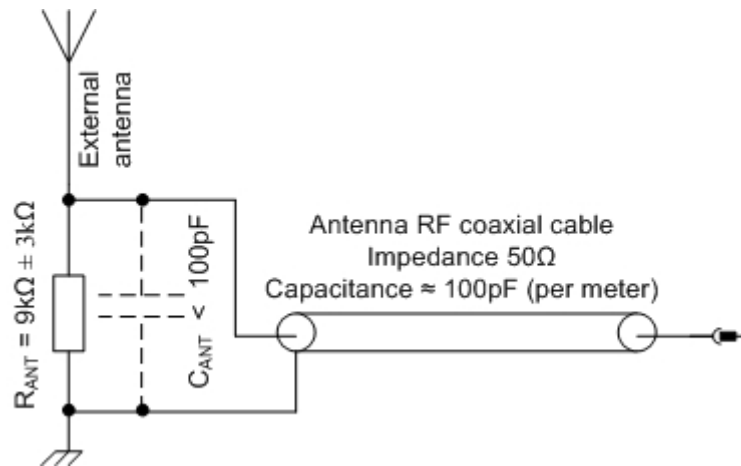
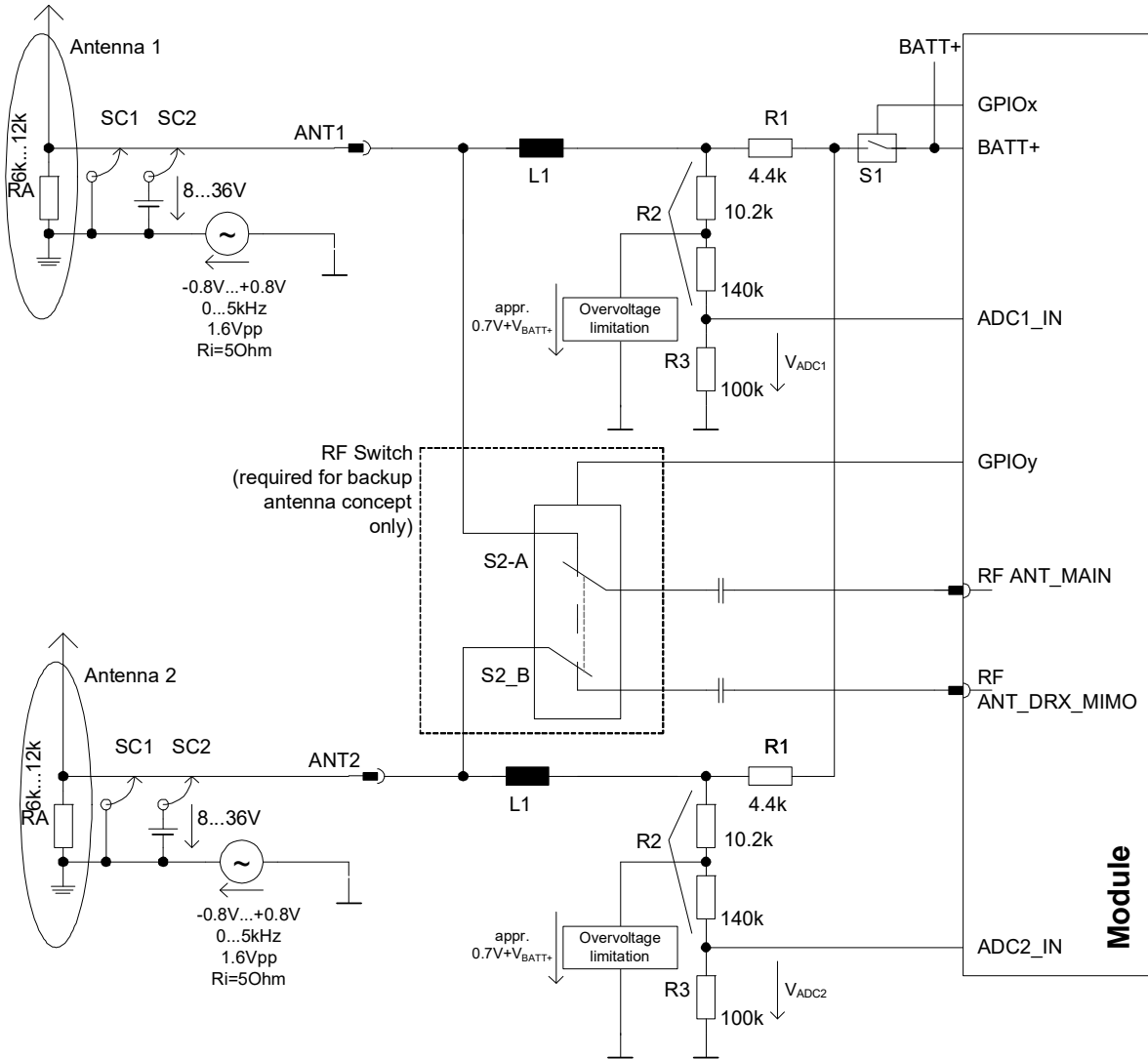

Figure 38 shows the basic principles of an antenna detection circuit that is able to detect two antennas and verify their connection status. The GPIO pads can be employed to enable the antenna detection, the ADCx_IN pads can be used to measure the voltage of external devices connected to these ADC input pads - thus determining R_{ANT} values. The AT^SRADC write command configures the parameters required for ADC measurement and returns the measurement result(s) - for command details see [1].

Figure 38: Basic layout sample for antenna detection



The following [Table 18](#) lists possible signal states for the GPIOx and GPIOy signal lines in case these lines are configured and used for antenna detection. For GPIO configuration and control commands see [\[1\]](#).

Table 18: Possible GPIOx and GPIOy signal states if used for antenna diagnosis

Signal state	Meaning
GPIOx: Input Pull down or Output low Output high	Antenna detection control (S1 in above figure): Off (diagnostic measurement is off) On (diagnostic measurement is on)
GPIOy: Input Pull down or Output low Output high	Antenna switch control (RF switch in above figure): Antenna 1 Antenna 2

[Table 19](#) lists assured antenna diagnostic states depending on the measured R_{ANT} values. Note that the R_{ANT} ranges not mentioned in the below table, i.e., $1k\Omega...6k\Omega$ and $12k\Omega...40k\Omega$ are tolerance ranges. Within these tolerance ranges a decision threshold for a diagnostic application may be located. For more details on the sample antenna detection circuit please refer to [Section 8.2.](#)

Table 19: Assured antenna diagnostic states

Antenna state	R_{ANT} range
Normal operation, antenna connected (resistance at feed point as required)	$R_{ANT} = 6k\Omega...12k\Omega$
Antenna pad short-circuited to GND	$R_{ANT} = 0...1k\Omega$
Antenna not properly connected, or resistance at antenna feed point wrong or not present	$R_{ANT} = 40k\Omega...∞\Omega$
Antenna pad is short-circuited to the supply voltage of the host application, for example the vehicle's on-board power supply voltage	max. 36V

Measuring procedure for the basic layout sample given in [Figure 38](#):

The battery current flows through R1 and RA. The voltage drop on RA is divided by $R3/(R3+R2)$ and measured by the ADCx_IN input. For the ADCx_IN voltage V_{ADCx} (monitored using AT^SRADC) and the BATT+ supply voltage V_{BATT+} (monitored using AT^SBV) several measuring samples should be taken for averaging. The measured and averaged value V_{ADCx} will then be compared to three decision thresholds. The decision thresholds depend on BATT+:

Table 20: GSM/UMTS/LTE antenna diagnostic decision threshold

Decision threshold ¹		V_{ADCx}	Result
Short to GND	Appr. $0,176 * V_{BATT+}$ (580mV...738mV)	<	Short-circuited to ground
		>	Antenna connected
No antenna	Appr. $0,337 * V_{BATT+}$ (1111mV...1414mV)	<	Antenna nor properly connected
		>	
Short to power	$0.146+0.405 * V_{BATT+}$ (1482mV...1888mV)	<	Short-circuited to power
		>	

¹ The decision thresholds depends on BATT+ and has to be calculated separately for each decision (the BATT+ voltage level V_{BATT+} is known to the system: $3.3V \leq V_{BATT+} \leq 4.2V$).

5.2. GNSS Antenna Interface

In addition to the RF antenna interface ALS3-US R4 also has a GNSS antenna interface. See [Section 6.5](#) to find out where the GNSS antenna pad is located. The GNSS pad itself is the same as for the RF antenna interface (see [Section 5.1.1](#)).

It is possible to connect active or passive GNSS antennas. In either case they must have 50Ω impedance. The simultaneous operation of GSM/UMTS/LTE and GNSS is implemented. For electrical characteristics see [Section 6.9](#).

ALS3-US R4 provides the supply voltage VGNSS for the GNSS active antenna (3.05V). It has to be enabled by software when the GNSS receiver becomes active, otherwise VGNSS should be off (power saving). VGNSS is not short circuit protected. This will have to be provided for by an external application. The DC voltage should be fed back via ANT_GNSS_DC for coupling into the GNSS antenna path. [Figure 39](#) shows the flexibility in realizing the power supply for an active GNSS antenna - one with short circuit protection and one with an external LDO employed.

Figure 39: Supply voltage for active GNSS antenna

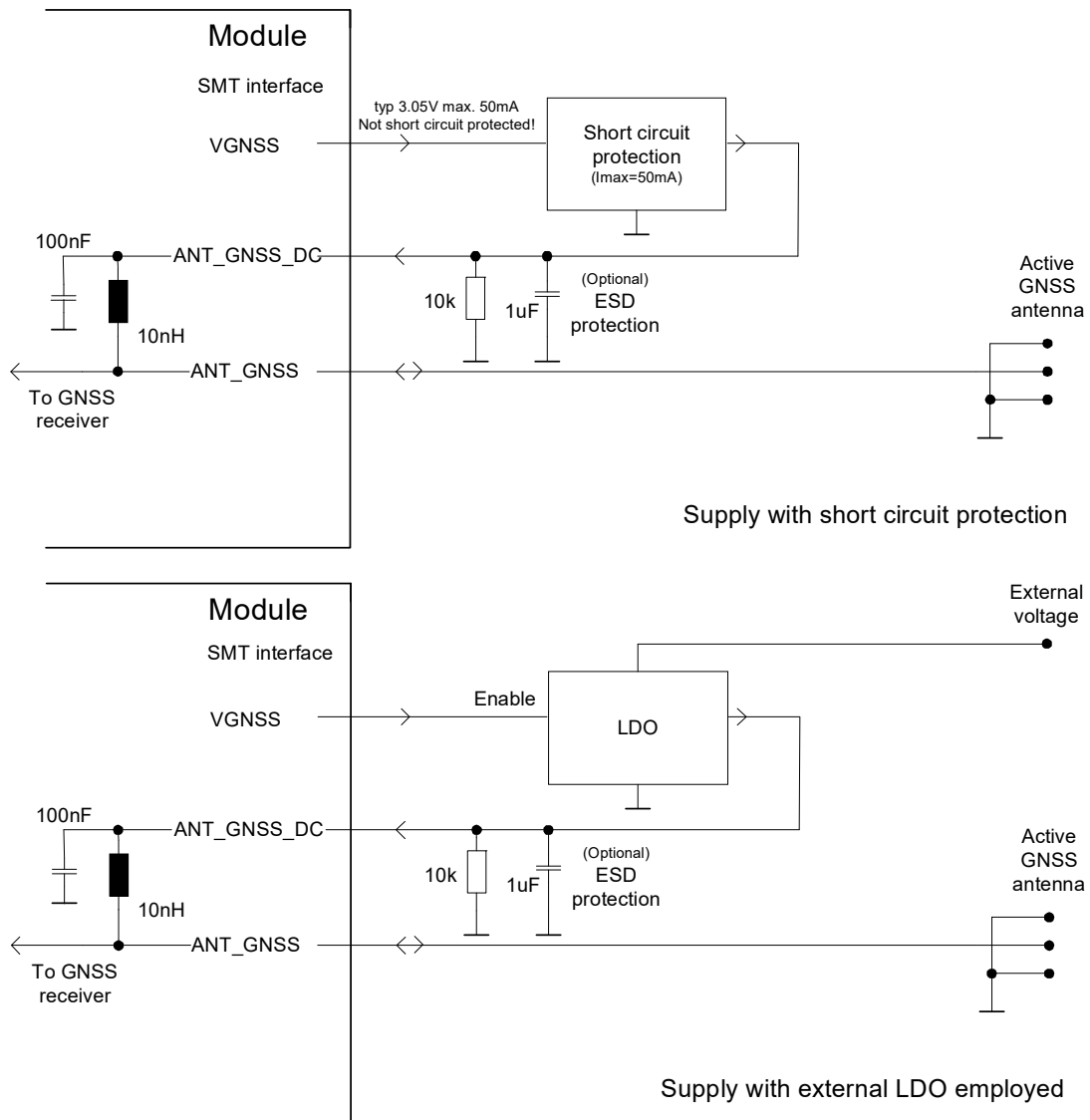
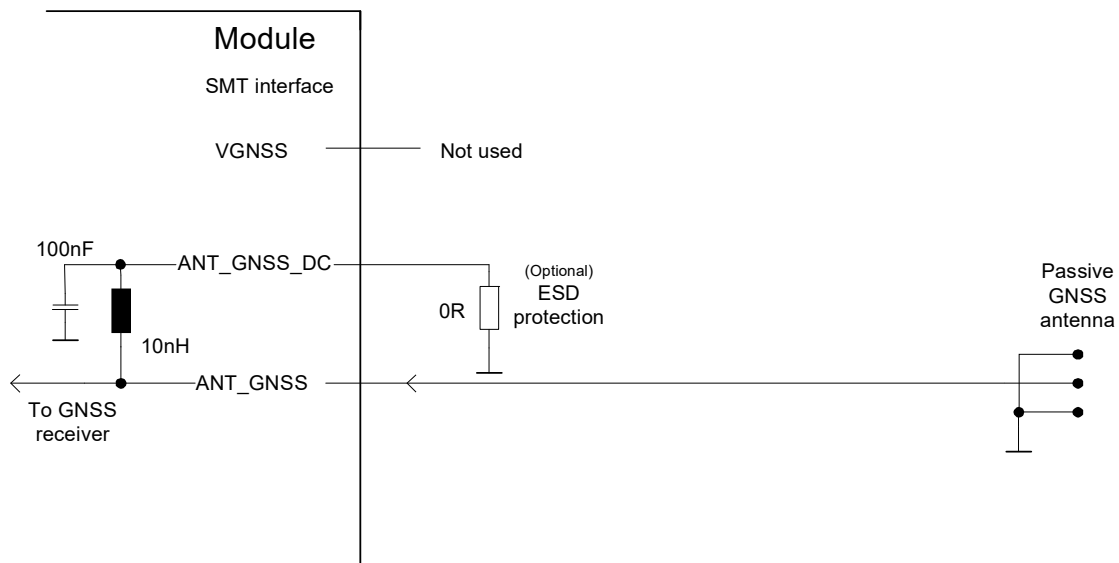

Figure 40 shows sample circuits realizing ESD protection for a passive GNSS antenna.

Figure 40: ESD protection for passive GNSS antenna



5.2.1. GNSS Antenna Diagnostic

GNSS antenna diagnosis does require an external detection circuit. The antenna DC supply current can be measured via ADC3_IN. The ADC3_IN input voltage (U_g) may be generated by a sample circuit shown in Figure 41. The circuit allows to check the presence and the connection status of an active GNSS antenna. Passive GNSS antennas cannot be detected. Therefore, GNSS antenna detection is only available in active GNSS antenna mode. This mode is configured by the AT command: AT^SGPSC (for details see [1]).

Having enabled the active GNSS antenna mode the presence and connection status of an active GNSS antenna can be checked using the AT command AT^SRADC to monitor ADC3_IN. The following table lists current ranges for possible antenna states as well as voltage ranges as decision thresholds to distinguish between the antenna connection states. Please refer to [1] for more information on the command AT^SRADC.

Table 21: Values of the GNSS antenna diagnostic measurements and their meaning

Antenna connection status	Current ranges (I_g) ¹	Voltage ranges (U_g)
Antenna not connected	<1.4mA	
Decision threshold		59mV ±20%
Antenna connected	2.2mA...20mA	
Decision threshold		825mV ±20%
Antenna short circuited to ground	>30mA	
GNSS antenna detection is not possible because GNSS antenna power supply is switched off.	--	

¹ Please note that the mA ranges 1.4mA...2.2mA and 20mA...30mA are tolerance ranges. The decision threshold should be defined within these ranges.

Figure 41: Sample GNSS antenna detection circuit

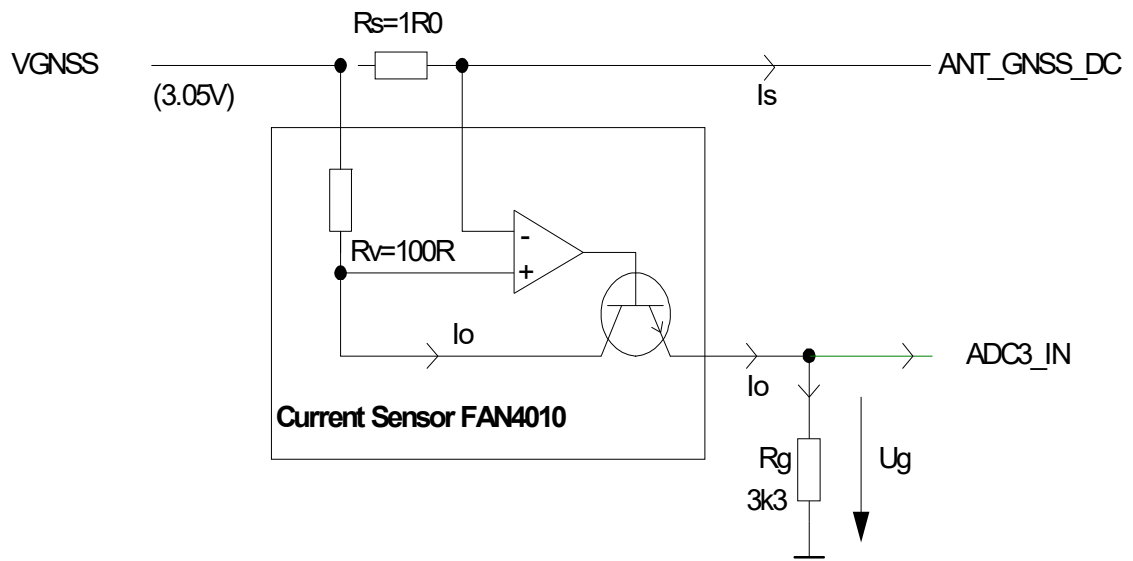

$$U_g = R_g * I_s * R_s / R_v$$

$$U_{gmax} = 1.5V$$

6/ Electrical, Reliability and Radio Characteristics

6.1. Absolute Maximum Ratings

The absolute maximum ratings stated in [Table 22](#) are stress ratings under any conditions. Stresses beyond any of these limits will cause permanent damage to ALS3-US R4.

Table 22: Absolute maximum ratings

Parameter	Min	Max	Unit
Supply voltage BATT+	-0.5	+6.0	V
Voltage at all digital lines in Power Down mode	-0.5	+0.5	V
Voltage at digital lines in normal operation	-0.5	+2.3	V
Voltage at SIM/USIM interface, CCVCCx 1.8V in normal operation	-0.5	+2.3	V
Voltage at SIM/USIM interface, CCVCCx 3.0V in normal operation	-0.5	+3.4	V
Voltage at analog audio pads in normal operation (VMIC=on)	-0.3	+3.3	V
Voltage at analog audio pads during audio off mode (VMIC=off)	-0.3	+0.3	V
VDDL input voltage	-0,3	+3.5	V
Voltage at ADC lines if the module is powered by BATT+	-0.5	+3.5	V
Voltage at ADC lines if the module is not powered	-0.5	+0.5	V
VEXT maximum current shorted to GND		-300	mA
VUSB_IN, USB_DN, USB_DP	-0.3	5.75	V
Voltage at PWR_IND line	-0.5	5.5	V
PWR_IND input current if PWR_IND= low		2	mA
Voltage at following signals: IGT, EMERG_OFF	-0.5	2.5	V
GNSS antenna supply VGNSS		300	mA

6.2. Operating Temperatures

Table 23: Board temperature

Parameter	Min	Typ	Max	Unit
Operating temperature range	-30	+25	+85	°C
Restricted temperature range ¹	-40		+95	°C
Automatic shutdown ² Temperature measured on ALS3-US R4 board	---	---	>+95	°C

¹ Restricted operation allows normal mode data transmissions for limited time until automatic thermal shutdown takes effect. Within the restricted temperature range (outside the operating temperature range) the specified electrical characteristics may be in- or decreased.

² Due to temperature measurement uncertainty, a tolerance on the stated shutdown thresholds may occur. The possible deviation is in the range of $\pm 2^\circ\text{C}$ at the over-temperature limit.

6.3. Storage Conditions

The conditions stated below are only valid for modules in their original packed state in weather protected, non-temperature-controlled storage locations. Normal storage time under these conditions is 12 months maximum. The modules will be delivered in a packaging that meets the requirements according "IPD/JEDEC J-STD-033B.1" for Low Temperature Carriers.

Table 24: Storage conditions

Type	Condition	Unit	Reference
Humidity relative: Low High	10 90 at 40°C	%	IPC/JEDEC J-STD-033A
Air pressure: Low High	70 106	kPa	IEC TR 60271-3-1: 1K4 IEC TR 60271-3-1: 1K4
Movement of surrounding air	1.0	m/s	IEC TR 60271-3-1: 1K4
Water: rain, dripping, icing and frosting	Not allowed	---	---
Radiation: Solar Heat	1120 600	W/m ²	ETS 300 019-2-1: T1.2, IEC 60068-2-2 Bb ETS 300 019-2-1: T1.2, IEC 60068-2-2 Bb
Chemically active substances	Not recommended		IEC TR 60271-3-1: 1C1L
Mechanically active substances	Not recommended		IEC TR 60271-3-1: 1S1
Vibration sinusoidal: Displacement Acceleration Frequency range	1.5 5 2-9 9-200	mm m/s ² Hz	IEC TR 60271-3-1: 1M2
Shocks: Shock spectrum Duration Acceleration	Semi-sinusoidal 1 50	ms m/s ²	IEC 60068-2-27 Ea

6.4. Reliability Characteristics

The test conditions stated below are an extract of the complete test specifications.

Table 25: Summary of reliability test conditions

Type of test	Conditions	Standard
Vibration	Frequency range: 10-20Hz; acceleration: 5g Frequency range: 20-500Hz; acceleration: 20g Duration: 20h per axis; 3 axes	DIN IEC 60068-2-6 ¹
Shock half-sinus	Acceleration: 500g Shock duration: 1ms 1 shock per axis 6 positions ($\pm x$, y and z)	DIN IEC 60068-2-27
Dry heat	Temperature: $+70 \pm 2^\circ\text{C}$ Test duration: 16h Humidity in the test chamber: < 50%	EN 60068-2-2 Bb ETS 300 019-2-7
Temperature change (shock)	Low temperature: $-40^\circ\text{C} \pm 2^\circ\text{C}$ High temperature: $+85^\circ\text{C} \pm 2^\circ\text{C}$ Changeover time: < 30s (dual chamber system) Test duration: 1h Number of repetitions: 100	DIN IEC 60068-2-14 Na ETS 300 019-2-7
Damp heat cyclic	High temperature: $+55^\circ\text{C} \pm 2^\circ\text{C}$ Low temperature: $+25^\circ\text{C} \pm 2^\circ\text{C}$ Humidity: 93% $\pm 3\%$ Number of repetitions: 6 Test duration: 12h + 12h	DIN IEC 60068-2-30 Db ETS 300 019-2-5
Cold (constant exposure)	Temperature: $-40 \pm 2^\circ\text{C}$ Test duration: 16h	DIN IEC 60068-2-1

¹ For reliability tests in the frequency range 20-500Hz the Standard's acceleration reference value was increased to 20g.

6.4.1. Bending Tests

From experience with other modules an elongation of up to 200µm/m is acceptable for ALS3-US R4 modules as a result of bending strains.

Tests (based on EN 60068-2-21) showed that if applying a force of 10N at the middle of the module, i.e., the evaluation module with the actual ALS3-US R4 module soldered onto the evaluation PCB as shown in Figure 42, the possible elongation is clearly below the value of 200µm/m. Therefore, a force of 10N is recommended as maximum force.

Please note that these values only apply for a one-off short stress. The module will have to be mounted free of any strains and without being exposed to dynamic pressures.

Figure 42: Bending test setup

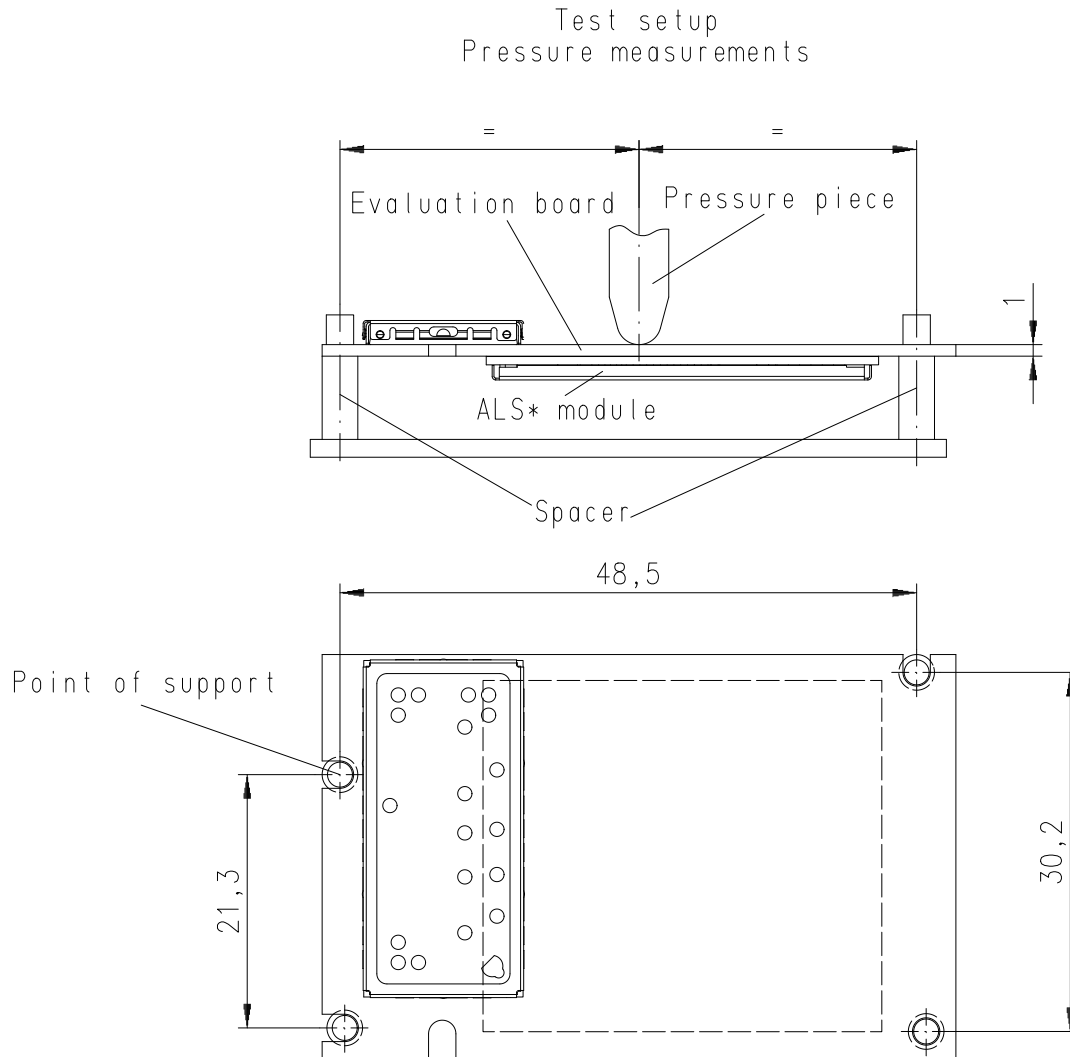

6.5. Pad Assignment and Signal Description

The SMT application interface on the ALS3-US R4 provides connecting pads to integrate the module into external applications. Table 26 lists the pads' assignments. Figure 44 (bottom view) and Figure 44 (top view) show the connecting pads' numbering plan.

Please note that pads marked "rfu" (reserved for future use) and further qualified as "dnu" (do not use) may be soldered but should not be connected to an external application. Pads marked "rfu" and qualified as "GND" (ground) are assigned to ground with ALS3-US R4 modules, but may have different assignments with future Kontron products using the same pad layout.

Kontron strongly recommends to solder all connecting pads for mechanical stability and heat dissipation.

Table 26: Overview: Pad assignments¹

Pad No.	Signal Name	Pad No.	Signal Name	Pad No.	Signal Name
A4	nc	E2	GND	L2	GND
A5	GND	E3	GND	L3	GND
A6	GND	E4	GND	L4	GND
A7	rfu (dnu)	E5	GND	L5	rfu (dnu)
A8	GND	E12	CCIO2	L6	CCVCC2
A9	GND	E13	CCRST2	L7	rfu (dnu)
A10	GND	E14	rfu (dnu)	L8	rfu (dnu)
A11	GND	E15	EPP	L9	rfu (dnu)
A12	ANT_DRX_MIMO	E16	EPN	L10	rfu (dnu)
A13	GND	F1	GND	L11	rfu (dnu)
B3	nc	F2	GND	L12	rfu (dnu)
B4	GND	F3	GND	L13	rfu (dnu)
B5	GND	F4	GND	L14	CCRST1
B6	GND	F13	rfu (dnu)	L15	CCCLK1
B7	GND	F14	rfu (dnu)	L16	IGT
B8	GND	F15	rfu (dnu)	M2	GND
B9	GND	F16	GPIO10	M3	GND
B10	GND	G1	GND	M4	PWR_IND
B11	GND	G2	GND	M5	VEXT
B12	GND	G3	GND	M6	GND
B13	GND	G4	rfu (dnu)	M7	DIN
B14	STATUS	G13	rfu (dnu)	M8	BCLK
C2	GND	G14	GPIO7	M9	FSC
C3	GND	G15	GPIO8	M10	DOUT
C4	GND	G16	GPIO9	M11	ADC3_IN
C5	GND	H1	GND	M12	ADC2_IN
C6	GND	H2	GND	M13	ADC1_IN
C7	GND	H3	GND	M14	CCIN1
C8	GND	H4	GND	M15	VDDL
C9	GND	H13	rfu (dnu)	N3	BATT+ RF
C10	GND	H14	GPIO4	N4	BATT+ RF
C11	GND	H15	GPIO5	N5	VUSB_IN
C12	rfu (dnu)	H16	GPIO6	N6	rfu (dnu)
C13	rfu (dnu)	J1	GND	N7	rfu (dnu)
C14	VMIC	J2	GND	N8	CTS0
C15	AGND	J3	GND	N9	DCD0
D1	GND	J4	GND	N10	RTS0
D2	GND	J13	GND	N11	GND
D3	GND	J14	GPIO1	N12	rfu (dnu)
D4	GND	J15	GPIO2	N13	BATT+
D5	ANT_GNSS_DC	J16	GPIO3	N14	EMERG_OFF
D6	GND	K1	ANT_MAIN	P4	USB_DP
D7	GND	K2	GND	P5	USB_DN
D8	GND	K3	GND	P6	MCLK
D9	GND	K4	GND	P7	rfu (dnu)
D10	GND	K5	GND	P8	DTR0
D11	GND	K12	rfu (dnu)	P9	DSR0
D12	CCIN2	K13	rfu (dnu)	P10	RINGO
D13	rfu (dnu)	K14	CCIO1	P11	RXD0
D14	CCCLK2	K15	CCVCC1	P12	TXD0
D15	MICP	K16	VGNSS	P13	BATT+
D16	MICN	L1	GND		
E1	ANT_GNSS				

¹ nc = not connected; rfu = reserved for future use; dnu = do not use

Figure 43: ALS3-US R4 bottom view: Pad assignments

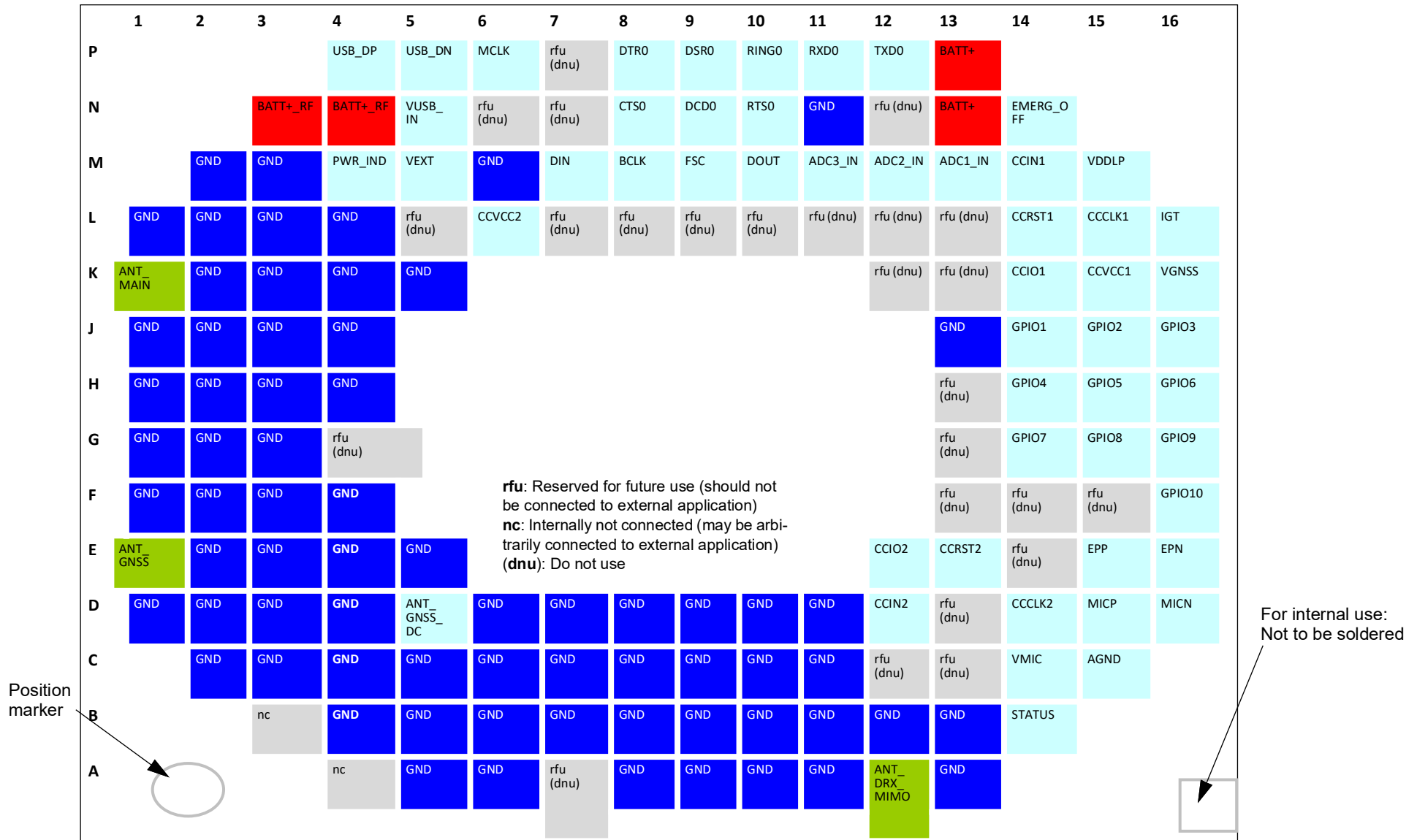
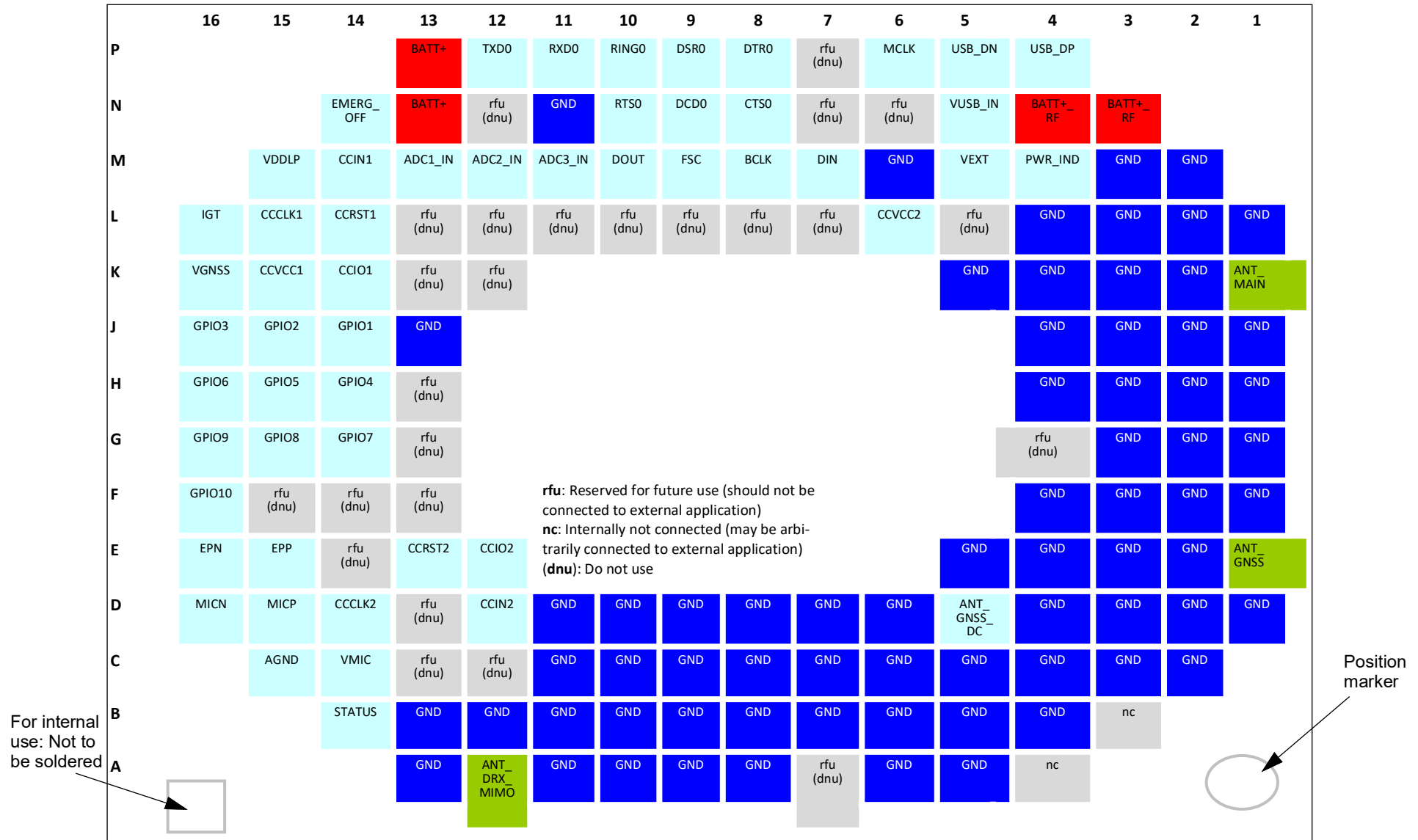

Figure 44: ALS3-US R4 top view: Pad assignments



Please note that the reference voltages listed in [Table 27](#) are the values measured directly on the ALS3-US R4 module. They do not apply to the accessories connected.

Table 27: Signal description

Function	Signal name	IO	Signal form and level	Comment
Power supply	BATT+_RF	I	$V_{I,max} = 4.2V$ $V_{I,norm} = 3.8V$ $V_{I,min} = 3.3V$ during Tx burst on board $I_{max} \approx 2A$, during Tx burst (GSM)  $n \text{ Tx} = n \times 577\mu s$ peak current every 4.615ms	Lines of BATT+ and GND must be connected in parallel for supply purposes because higher peak currents may occur. Minimum voltage must not fall below 3.3V including drop, ripple, spikes.
	BATT+	I	$V_{I,max} = 4.2V$ $V_{I,norm} = 3.8V$ $V_{I,min} = 3.3V$ during Tx burst on board $I_{max} = 350mA$	
Power supply	GND		Ground	Application Ground
External supply voltage	VEXT	O	$CL_{max} = 1\mu F$ $V_O = 1.80V \pm 1\% - 5\%$ $I_{O,max} = -50mA$	VEXT may be used for application circuits. If unused keep line open. The external digital logic must not cause any spikes or glitches on voltage VEXT. Do not exceed IOmax
Supply voltage for active GNSS antenna (Output)	VGNSS	O	$CL_{max} = 2.2\mu$ $V_O = 3.05V \pm 1\%$ $@I_O = -20mA$ $I_{O,max} = -50mA$	Available if GNSS antenna DC power is enabled (configurable by AT command; see Section 6.9).
Supply voltage for active GNSS antenna (Input)	ANT_GNSS_DC	I	$V_{I,max} = 6V$ The input current has to be limited at 50mA (antenna short circuit protection)	If unused connect to GND.
Ignition	IGT	I	$R_{pU} \approx 200k\Omega$ $V_{OH,max} = 1.8V$ $V_{IH,max} = 2.1V$ $V_{IH,min} = 1.17V$ $V_{IL,max} = 300mV$ Low impulse width > 100ms	This signal switches the module ON. It is required to drive this line low by an open drain or open collector driver connected to GND.
Emergency off	EMERG_OFF	I	$R_{pU} \approx 40k\Omega$ $V_{OH,max} = 1.8V$ $V_{IH,max} = 2.1V$ $V_{IH,min} = 1.17V$ $V_{IL,max} = 300mV$  low impulse width > 40ms	It is required to drive this line low by an open drain or open collector driver connected to GND. If unused keep line open.
RTC Back up	VDDL	O	$V_{O,max} = 3.20V$ while BATT+ =>3.3V $R_I = 1.8k\Omega$	If unused keep line open.
		I	$V_I = 1.5V \dots 3.25V$ at $I_{max} = 10\mu A$ while BATT+ = 0V	
Connectivity status	STATUS	O	$V_{OI,max} = 0.45V$ at $I = 2mA$ $V_{OH,min} = 1.35V$ at $I = -2mA$ $V_{OH,max} = 1.85V$	Status signaling e.g. with ext. LED circuit

Table 27: Signal description

Function	Signal name	IO	Signal form and level	Comment
SIM card detection (2x)	CCIN1	I	$R_{PU} \approx 24.2k\Omega$ $V_{OHmax} = 2.0V$ $V_{IHmin} = 1.15V$ $V_{IHmax} = 1.9V$ $V_{ILmax} = 0.4V$	CCINx = Low, SIM card inserted. If SIM card holder does not support CCIN, connect to GND.
	CCIN2	I	$V_{IHmin} = 1.20V$ at $-30\mu A$ $V_{IHmax} = 2V$ $V_{ILmax} = 0.6V$ at $30\mu A$	CCIN2: External pull-up required - for details please refer to Section 3.8. If 2 nd SIM interface not used, keep line open.
3V SIM card interface	CCRST1 CCRST2	O	$V_{OLmax} = 0.45V$ at $I = 2mA$ $V_{OHmin} = 2.57V$ at $I = -2mA$ $V_{OHmax} = 3.08V$	Maximum cable length or copper track should be not longer than 100mm to SIM card holder. CCIO2: External 10k Ω pull-up required - for details please refer to Section 3.8. If 2 nd SIM interface not used, keep lines open.
	CCIO1 CCIO2	I/O	CCIO1: $R_{PU} \approx 4.8...9.5k\Omega$ CCIO2: $R_{PU} \approx 9.2...190k\Omega$ $V_{ILmax} = 0.76V$ $V_{ILmin} = -0.3V$ $V_{IHmin} = 1.98V$ $V_{IHmax} = 3.35V$ $V_{OLmax} = 0.45V$ at $I = 2mA$ $V_{OHmin} = 2.57V$ at $I = -0.05mA$ $V_{OHmax} = 3.08V$	
	CCCLK1 CCCLK2	O	$V_{OLmax} = 0.45V$ at $I = 2mA$ $V_{OHmin} = 2.57V$ at $I = -2mA$ $V_{OHmax} = 3.08V$	
	CCVCC1 CCVCC2	O	$V_{Omin} = 3.0V$ $V_{Otyp} = 3.05V$ $V_{Omax} = 3.08V$ $I_{Omax} = -50mA$	
1.8V SIM card interface	CCRST1 CCRST2	O	$V_{OLmax} = 0.45V$ at $I = 2mA$ $V_{OHmin} = 1.35V$ at $I = -2mA$ $V_{OHmax} = 1.85V$	Maximum cable length or copper track should be not longer than 100mm to SIM card holder. CCIO2: External 10k Ω pull-up required - for details please refer to Section 3.8. If 2 nd SIM interface not used, keep lines open.
	CCIO1 CCIO2	I/O	CCIO1: $R_{PU} \approx 4.8...9.5k\Omega$ CCIO2: $R_{PU} \approx 9.2...190k\Omega$ $V_{ILmax} = 0.62V$ $V_{ILmin} = -0.3V$ $V_{IHmin} = 1.20V$ $V_{IHmax} = 2.1V$ $V_{OLmax} = 0.45V$ at $I = 2mA$ $V_{OHmin} = 1.32V$ at $I = -0.05mA$ $V_{OHmax} = 1.82V$	
	CCCLK1 CCCLK2	O	$V_{OLmax} = 0.45V$ at $I = 2mA$ $V_{OHmin} = 1.32V$ at $I = -2mA$ $V_{OHmax} = 1.82V$	
	CCVCC1 CCVCC2	O	$V_{Omin} = 1.75V$ $V_{Otyp} = 1.80V$ $V_{Omax} = 1.82V$ $I_{Omax} = -50mA$	

Table 27: Signal description

Function	Signal name	IO	Signal form and level	Comment
Serial Modem Interface ASCO	RXD0	O	$V_{OLmax} = 0.45V$ at $I = 2mA$ $V_{OHmin} = 1.35V$ at $I = -2mA$ $V_{OHmax} = 1.85V$	If unused keep line open.
	CTS0	O		
	DSR0	O		
	DCD0	O		
	RING0	O	$V_{ILmax} = 0.6V$ at $30\mu A$ $V_{IHmin} = 1.20V$ at $-30\mu A$ $V_{IHmax} = 2V$	
	TXD0	I		
	RTS0	I		
	DTR0	I		
Power indicator	PWR_IND	O	$V_{IHmax} = 5.5V$ $V_{OLmax} = 0.4V$ at $I_{max} = 1mA$	<p>PWR_IND (Power Indicator) notifies the module's on/off state.</p> <p>PWR_IND is an open collector that needs to be connected to an external pull-up resistor. Low state of the open collector indicates that the module is on. Vice versa, high level notifies the Power Down mode.</p> <p>Therefore, signal may be used to enable external vol-tage regulators that supply an external logic for communication with the module, e.g. level converters.</p>
Host wakeup	RING0	O	$V_{OLmax} = 0.45V$ at $I = 2mA$ $V_{OHmin} = 1.35V$ at $I = -2mA$ $V_{OHmax} = 1.85V$	If unused keep line open.
USB	VUSB_IN	I	$V_{INmin} = 3.0V$ $V_{INmax} = 5.25V$ $I_{I,typ} = 150\mu A$ $I_{I,max} = 200\mu A$ $C_{in} = 1\mu F$ In case of $V_{ripple} \geq 10mV_{pp}$ (with $f > 300kHz$), and V_{BUS_IN} driven in the voltage range $4.08V \dots 4.11V$, use of an RC filter $1k\Omega/100nF$ is required.	<p>If the USB interface is not used please connect this line to GND.</p> <p>Since VUSB_IN is used for detection only it is recommended not to add any further blocking capacitors on the VUSB_IN line.</p>
	USB_DN	I/O	All electrical characteristics according to USB Implementers' Forum, USB 2.0 High Speed Specification.	<p>Keep lines open if VUSB_IN connects to GND.</p> <p>USB High Speed mode operation requires a differential impedance of 90Ω.</p>
	USB_DP	I/O		

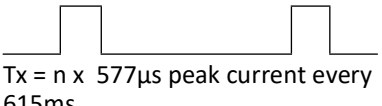
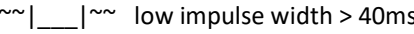
Table 27: Signal description

Function	Signal name	IO	Signal form and level	Comment
Analog Audio interface	VMIC	O	$V_{O\text{typ}} = 2.4\text{V}$ $I_{\text{max}} = 3\text{mA}$	Microphone supply for customer feeding circuits. If unused keep line open.
	EPP	O	Differential, Minimum load resistance 16Ω typ. 5.0Vpp at no load PCM level = $+3\text{dBm0}$, 1.02kHz sine wave @ 0dB gain	Balanced output for earphone or balance output for line out. See also Section 6.7.4. If unused keep line open.
	EPN	O		
	MICP	I	$Z_{i\text{typ}} = 36\text{k}\Omega$ @ 0dB gain $Z_{i\text{typ}} = 25\text{k}\Omega$ @ 30dB gain $V_{in\text{max}} = 2.7\text{Vpp}$ (for 3dBm0 @ 0dB gain)	Balanced differential microphone with external feeding circuit (using VMIC and AGND) or balanced differential line input. See also Section 6.7.4. Use coupling capacitors. If unused keep lines open.
	MICN	I		
AGND		Analog ground	GND level for external audio circuits	
Digital audio interface (PCM or I ² S)	DIN	I	$V_{IL\text{max}} = 0.6\text{V}$ at $30\mu\text{A}$ $V_{IH\text{min}} = 1.20\text{V}$ at $-30\mu\text{A}$ $V_{IH\text{max}} = 2\text{V}$ $V_{OL\text{max}} = 0.45\text{V}$ at $I = 2\text{mA}$ $V_{OH\text{min}} = 1.35\text{V}$ at $I = -2\text{mA}$ $V_{OH\text{max}} = 1.85\text{V}$	PCM Master/Slave mode. I ² S Master mode. If unused keep lines open.
	BCLK	I/O		
	FSC	I/O		
	DOUT	O		
	MCLK	O	$V_{OL\text{max}} = 0.45\text{V}$ at $I = 2\text{mA}$ $V_{OH\text{min}} = 1.35\text{V}$ at $I = -2\text{mA}$ $V_{OH\text{max}} = 1.85\text{V}$ $F=2048\text{KHz}$ (at 8KHz sample rate) $F=4096\text{KHz}$ (at 16KHz sample rate)	Master clock option for audio codecs without PLL. If unused keep line open.
GPIO interface	GPIO1 GPIO2 GPIO3 GPIO4 GPIO5 GPIO6 GPIO7 GPIO8 GPIO9 GPIO10	I/O	$V_{IL\text{max}} = 0.6\text{V}$ at $30\mu\text{A}$ $V_{IH\text{min}} = 1.20\text{V}$ at $-30\mu\text{A}$ $V_{IH\text{max}} = 2\text{V}$ $V_{OL\text{max}} = 0.45\text{V}$ at $I = 2\text{mA}$ $V_{OH\text{min}} = 1.35\text{V}$ at $I = -2\text{mA}$ $V_{OH\text{max}} = 1.85\text{V}$	If unused keep lines open. Following functions can be configured for GPIOs using AT commands: GPIO1 --> Dead reckoning synchronization GPIO2 --> 700MHz antenna control switch Any GPIO --> Low current indication. By default GPIO6 is configured as LCI line. Any GPIO --> Remote host wakeup line
Dead reckoning synchronization	GPIO1 (DR_SYNC)	O	$V_{OL\text{max}} = 0.45\text{V}$ at $I = 2\text{mA}$ $V_{OH\text{min}} = 1.35\text{V}$ at $I = -2\text{mA}$ $V_{OH\text{max}} = 1.85\text{V}$	1 pulse per second dead reckoning synchronization signal for usage in external dead reckoning applications (see Chapter 4 /).
700MHz antenna control switch	GPIO2 (ANT_SWITCH)	O	$V_{OL\text{max}} = 0.45\text{V}$ at $I = 2\text{mA}$ $V_{OH\text{min}} = 1.35\text{V}$ at $I = -2\text{mA}$ $V_{OH\text{max}} = 1.85\text{V}$	Line can be configured as a control signal for a possible external 700MHz antenna switch (see Section 3.13.6 /).

Table 27: Signal description

Function	Signal name	IO	Signal form and level	Comment
Low Current Indication	GPIOx (LCI_IND)	O	$V_{OLmax} = 0.45V$ at $I = 2mA$ $V_{OHmin} = 1.35V$ at $I = -2mA$ $V_{OHmax} = 1.85V$	If the feature is enabled (see Section 3.13.4.).
		I	$V_{IHmax} = 2V$ $R_{PD} = \text{appr. } 100k\Omega$	If the feature is disabled (see Section 3.13.4.).
Remote host wakeup	GPIOx	O	$V_{OLmax} = 0.45V$ at $I = 2mA$ $V_{OHmin} = 1.35V$ at $I = -2mA$ $V_{OHmax} = 1.85V$	If feature is enabled (see Section 3.13.3.).
ADC interface	ADC1_IN, ADC2_IN, ADC3_IN	I	Full specification compliance range $V_{Imin} \geq 0.3V$ $V_{Imax} \leq 3.075V$ Degraded accuracy range $V_{Imin} 0.05V \dots 0.3V$ $R_{id} > 1M\Omega$ Resolution: 12 Bit Offset error: $< \pm 10mV$ Gain error: $< 1\%$ analog bandwidth: $< 16kHz$ conversion time: $853\mu s$	If unused keep line open. Prepared for general purpose and antenna diagnostic use.

6.6. Power Supply Ratings

Table 28 and Table 34 assemble various voltage supply and current consumption ratings of the module.

Table 28: Voltage supply ratings

	Description	Conditions	Min	Typ	Max	Unit
BATT+	Supply voltage	Directly measured at Module. Voltage must stay within the min/max values, including voltage drop, ripple, spikes	3.3	3.8	4.2	V
	Maximum allowed voltage drop during transmit burst	Normal condition, power control level for Pout max			400	mV
	Voltage ripple	Normal condition, power control level for Pout max @ f <= 250 kHz @ f > 250 kHz			120 90	mV _{pp} mV _{pp}

Table 29: Current consumption ratings

	Description	Conditions	Typical rating	Unit	
$I_{VDDL P}$ @ 3V	OFF state supply current	Power Down	4	μ A	
I_{BATT+}^1	OFF State supply current	Power Down	40	μ A	
	Average GSM / GPRS supply current	SLEEP ² @ DRX=9 (no communication via UART)	USB disconnected	2.0	mA
		SLEEP ² @ DRX=5 (no communication via UART)	USB disconnected	2.5	mA
		SLEEP ² @ DRX=2 (no communication via UART)	USB disconnected	3.7	mA
	IDLE @ DRX=2 UART active, but no communication		USB disconnected	40	mA
			USB active	50	mA
	Voice call GSM850/900; PCL=5		@50 Ω	330	mA
	GPRS Data transfer GSM850/ 900; PCL=5; 1Tx/4Rx		ROPR=8 (max. reduction)	320	mA
			ROPR=4 (no reduction)		
	GPRS Data transfer GSM850/ 900; PCL=5; 2Tx/3Rx		ROPR=8 (max. reduction)	430	mA
ROPR=4 (no reduction)			540		
GPRS Data transfer GSM850/ 900; PCL=5; 4Tx/1Rx		ROPR=8 (max. reduction)	600	mA	
		ROPR=4 (no reduction)	930		
		@ total mismatch	990		

Table 29: Current consumption ratings

	Description	Conditions	Typical rating	Unit	
I_{BATT+}^1	Average GSM / GPRS supply current	EDGE Data transfer GSM850/900; PCL=5; 1Tx/4Rx	ROPR=8 (max. reduction)	220	mA
			ROPR=4 (no reduction)		
		EDGE Data transfer GSM850/900; PCL=5; 2Tx/3Rx	ROPR=8 (max. reduction)	300	mA
			ROPR=4 (no reduction)	340	
		EDGE Data transfer GSM850/900; PCL=5; 4Tx/1Rx	ROPR=8 (max. reduction)	490	mA
			ROPR=4 (no reduction)	570	
		Voice call GSM1800/1900; PCL=0	@50Ω	240	mA
		GPRS Data transfer GSM1800/1900; PCL=0; 1Tx/4Rx	ROPR=8 (max. reduction)	230	mA
			ROPR=4 (no reduction)		
		GPRS Data transfer GSM1800/1900; PCL=0; 2Tx/3Rx	ROPR=8 (max. reduction)	300	mA
			ROPR=4 (no reduction)	360	
		GPRS Data transfer GSM1800/1900; PCL=0; 4Tx/1Rx	ROPR=8 (max. reduction)	410	mA
			ROPR=4 (no reduction)	590	
		EDGE Data transfer GSM1800/1900; PCL=0; 1Tx/4Rx	ROPR=8 (max. reduction)	190	mA
			ROPR=4 (no reduction)		
		EDGE Data transfer GSM1800/1900; PCL=0; 2Tx/3Rx	ROPR=8 (max. reduction)	250	mA
ROPR=4 (no reduction)	290				
EDGE Data transfer GSM1800/1900; PCL=0; 4Tx/1Rx	ROPR=8 (max. reduction)	380	mA		
	ROPR=4 (no reduction)	460			
Peak current during GSM transmit burst	Voice call GSM850/900; PCL=5	@50Ω	2.1	A	
		@total mismatch	2.4		
	Voice call GSM1800/1900; PCL=0	@50Ω	1.3	A	
		@total mismatch	1.6		
I_{BATT+}^1	Average GSM supply current (GNSS on)	GSM active (UART/USB active); @DRX=2 & GNSS NMEA output off	65	mA	
		GSM active (UART/USB active); @DRX=2 & GNSS NMEA output on ³	85	mA	

Table 29: Current consumption ratings

	Description	Conditions		Typical rating	Unit	
I_{BATT+}^1	Average UMTS supply current	SLEEP ² @ DRX=9	USB disconnected	1.8	mA	
		SLEEP ² @ DRX=8	USB disconnected	2.1	mA	
	Data transfers measured @maximum Pout	SLEEP ² @ DRX=6	USB disconnected	3.3	mA	
		IDLE @ DRX=6	USB disconnected	30	mA	
			USB active	40	mA	
		Voice call Band II	@50Ω	580	mA	
			@total mismatch	700		
		Voice call Band IV		490	mA	
		Voice call Band V		470	mA	
		UMTS Data transfer Band II		580	mA	
		UMTS Data transfer Band IV		520	mA	
		UMTS Data transfer Band V		490	mA	
	HSPA Data transfer Band II		590	mA		
	HSPA Data transfer Band IV		540	mA		
	HSPA Data transfer Band V		510	mA		
	Average UMTS supply current (GNSS on)	WCDMA active (UART / USB active); @DRX=6 & GNSS NMEA output off		65	mA	
		WCDMA active (UART / USB active); @DRX=6 & GNSS NMEA output on ³		85	mA	
	Average LTE supply current ⁴	Data transfers measured @maximum Pout	SLEEP ² @ "Paging Occasions" = 256	USB disconnected	2.3	mA
			SLEEP ² @ "Paging Occasions" = 128	USB disconnected	2.7	mA
			SLEEP ² @ "Paging Occasions" = 64	USB disconnected	3.5	mA
SLEEP ² @ "Paging Occasions" = 32			USB disconnected	5.4	mA	
IDLE			USB disconnected	35	mA	
			USB active	45	mA	
LTE Data transfer Band 2			@ 50Ω	620	mA	
			@ total mismatch	740	mA	
LTE Data transfer Band 4				540	mA	
LTE Data transfer Band 5				550	mA	
LTE Data transfer Band 17				550	mA	
I_{BATT+}^1			Average LTE supply current (GNSS on)	LTE active (UART / USB active); @DRX=6 & GNSS NMEA output off		65
	LTE active (UART / USB active); @DRX=6 & GNSS NMEA output on ³			85	mA	
I_{VUSB_IN}	USB typical and maximum ratings are mentioned in Table 27: VUSB_IN .					

¹ With an impedance of $Z_{LOAD}=50\Omega$ at the antenna pads. Measured at 25°C and 4.2V - except for Power Down ratings that were measured at 3.4V.

² Measurements start 6 minutes after switching ON the module, Averaging times: SLEEP mode - 3 minutes, transfer modes - 1.5 minutes
Communication tester settings: no neighbor cells, no cell reselection etc, RMC (Reference Measurement Channel)

³ One fix per second.

⁴ Communication tester settings:
- Channel Bandwidth: 5MHz, Number of Resource Blocks: 25 (DL), 1 (UL), Modulation: QPSK

6.7. Electrical Characteristics of the Voiceband Part

6.7.1. Setting Audio Parameters by AT Commands

The audio modes 1 to 6 can be temporarily adjusted according to the AT command parameters listed in the table below. The audio parameters are set with the AT commands AT^SNFI as well as AT^SNFO and the audio mode is changed by AT^SNFS (see [1]). For a model of how the parameters influence the audio signal path see Section 6.7.2..

Table 30: Audio parameters adjustable by AT command

Parameter ¹	Influence to	Range	Gain range	Calculation
AT^SNFI=				
micAmp	MICP/MICN analog amplifier gain before ADC	0...63	-12...+35.25dB	0.75dB steps
adcVol	Digital gain of input signal after ADC in the codec	0, 1...255	Mute, -71.625...+23.625B	0.75dB steps
AT^SNFO=				
cdcRxVol	Analog gain of output signal after summation of sidetone	0...63	-57...+6dB	1dB steps
rxVolStep	Digital volume of output signal after speech decoder, before summation of sidetone and DAC.	0...5	-0...-15dB	3dB steps

¹ See [1] for command syntax and further parameter descriptions.

6.7.2. Audio Programming Model

The audio programming model shows how the signal path can be influenced by varying AT command parameters: AT^SNFI allows to set the parameters <micAmp>, and <adcVol>, whereas the parameters <cdcRxVol> and <rxVolStep> can be adjusted with AT^SNFO. For more information on the AT commands and parameters see Section 6.7.1. and [1].

Figure 45: Audio programming model

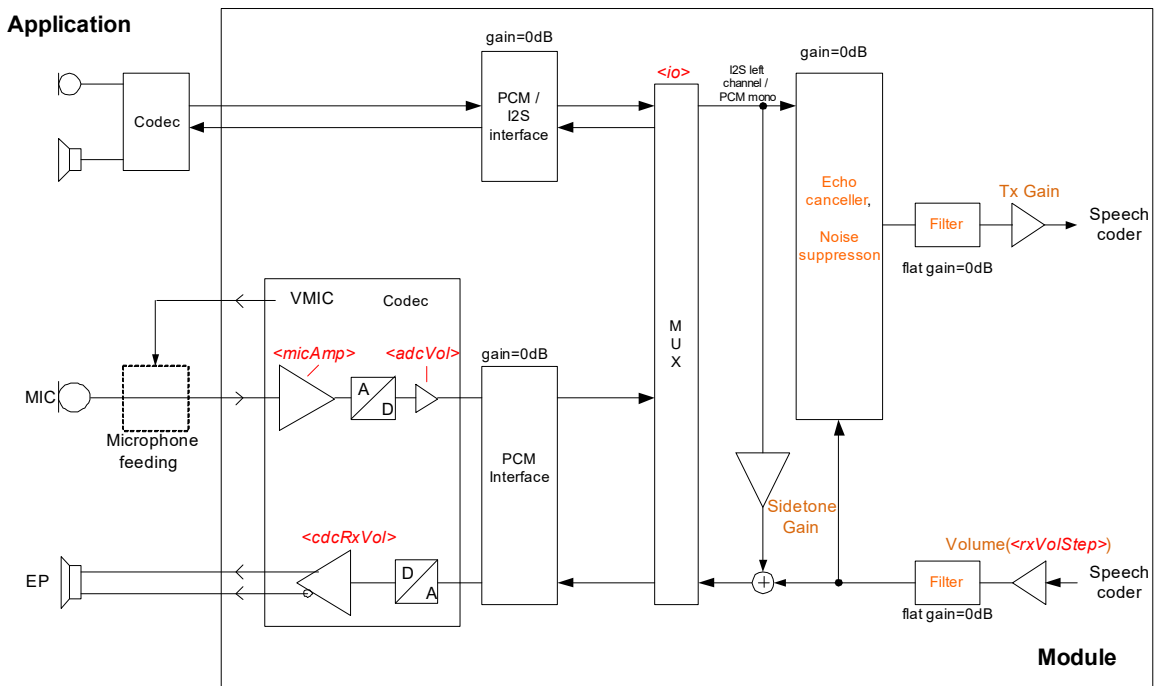

red: Audio mode parameters adjustable by AT commands
 orange: Selectable audio mode parameter (adjustable on request by Kontron)

6.7.3. Characteristics of Audio Modes

The electrical characteristics of the voiceband part depend on the current audio mode set with AT command. All values are noted for default gains, e.g. the default parameters are left unchanged.

Table 31: Voiceband characteristics

Audio mode no. AT^SNFS=	1	2	3	4	5	6
Name	Default Handset	Router	User Handset	Headset	Speaker phone	Transparent
Purpose	DSB with Votronic handset	Analog phone interface	Same as audio mode 1	Mono Headset	Handheld speakerphone	Direct access to speech coder
TX-Filters	Adjusted	Flat	Adjusted	Flat	Flat	Flat
RX-Filters	Adjusted to fit artificial ear type 3.2 low leakage	Flat	Adjusted to fit artificial ear type 3.2 low leakage	800Hz HP	800Hz HP	Flat
Default SNFI Parameters <micAmp> <adcVol> <txVol>(reserved)	56 (+30dB) 192 (0dB) 16384 (0dB)	56 (+30dB) 192 (0dB) 16384 (0dB)	56 (+30dB) 192 (0dB) 16384 (0dB)	56 (+30dB) 192 (0dB) 16384 (0dB)	56 (+30dB) 192 (0dB) 16384 (0dB)	56 (+30dB) 192 (0dB) 16384 (0dB)
Default SNFO Parameters <cdcRxGain> <rxVol>	54 (-3dB) 33 (0dB)	54 (-3dB) 33 (0dB)	54 (-3dB) 33 (0dB)	54 (-3dB) 33 (0dB)	54 (-3dB) 33 (0dB)	54 (-3dB) 33 (0dB)
Echo canceller Behaviour optimized for	ON low echo	ON low echo	ON low echo	ON moderate echo	ON high echo	OFF
Residual echo suppression with comfort noise generator	ON	ON	ON	ON	ON	OFF
Noise Reduction (Tx)	-12dB	-15dB	-12dB	-15dB	-15dB	OFF
MIC input signal for 0dBm0, ¹ f = 1024 Hz	15mV	22.5mV	15mV	22.5mV	22.5mV	22.5mV
EP output signal in mV rms. @ 0dBm0, 1024 Hz, no load (default gain)	300mV	790mV	300mV	610mV	635mV	790mV
Sidetone gain at default settings	19.4dB	-∞ dB	19.4dB	17.8dB	-∞ dB	-∞ dB
<i>Digital audio characteristics (PCM)</i>						
Uplink gain at 1024Hz	-1dB	0dB	-1dB	0dB	0dB	0dB
Downlink gain at 1024Hz	-12dB	0dB	-12dB	-2dB	-2dB	0dB
Sidetone Gain	-21.5dB	Mute	-21.5dB	-15dB	Mute	Mute

¹ All values measured before the noise reduction attenuates the sine wave after a few seconds.

Note: With regard to acoustic shock, the cellular application must be designed to avoid sending false AT commands that might increase amplification, e.g. for a highly sensitive earpiece. A protection circuit should be implemented in the cellular application.

6.7.4. Voiceband Receive Path

Test conditions:

- › The values specified below were tested to 1024Hz using AT^SNFO=57,33,0,0,43 in audio mode 6 during a GSM FR voice call unless otherwise stated.

Table 32: Voiceband receive path

Parameter	Min.	Typ.	Max.	Unit	Test condition / remark
Maximum differential output voltage (peak to peak) EPP to EPN		4.5 5.0		V V	16Ω No load @ 3.14dBm0 (full scale)
Nominal differential output voltage (peak to peak) EPP to EPN		3.1 3.4		V V	16Ω No load @ 0dBm0 (nominal scale)
Output bias voltage		1.4		V	From EPP or EPN to GND
Differential output load resistance	16			Ω	

6.7.5. Voiceband Transmit Path

Test conditions:

- › The values specified below were tested to 1024Hz using AT^SNFI=16,192,16384 in audio mode 6 during a GSM FR voice call unless otherwise stated.

Table 33: Voiceband transmit path

Parameter	Min.	Typ.	Max.	Unit	Test condition / Remark
Full scale input voltage (peak to peak) for 3.14dBm0 MICP to MICN		2.7		V	Balanced
Nominal input voltage (rms) for 0dBm0 MICP to MICN		0.7		V	Balanced
Microphone supply voltage VMIC		2.4		V	@ 3mA

6.8. RF Antenna Interface Characteristics

Table 34: RF Antenna interface GSM/UMTS/LTE (at operating temperature range¹)

Parameter	Conditions	Min.	Typical	Max.	Unit
LTE connectivity ²	Band 2, 4, 5, 17				
Receiver Input Sensitivity @ ARP (ch. bandwidth 5MHz)	LTE 700 Band 17	-97	-102		dBm
	LTE 850 Band 5	-98	-104		dBm
	LTE AWS Band 4	-100	-103		dBm
	LTE 1900 Band 2	-98	-103		dBm
RF Power @ ARP with 50Ω Load	LTE 700 Band 17	+21	+23	+25	dBm
	LTE 850 Band 5	+21	+23	+25	dBm
	LTE AWS Band 4	+21	+23	+25	dBm
	LTE 1900 Band 2	+21	+23	+25	dBm
UMTS/HSPA connectivity ²	Band II, IV, V				
Receiver Input Sensitivity @ ARP	UMTS 850 Band V	-104.7	-110		dBm
	UMTS AWS Band IV	-106.7	-110		dBm
	UMTS 1900 Band II	-104.7	-109		dBm
RF Power @ ARP with 50Ω Load	UMTS 850 Band V	+21	+24	+25	dBm
	UMTS AWS Band IV	+21	+24	+25	dBm
	UMTS 1900 Band II	+21	+24	+25	dBm
Tx noise @ ARP with max. RF power for UMTS: Band 1 channel 9777 Band 2 channel 9477	GNSS band		-170		dBm/Hz
GPRS coding schemes	Class 12, CS1 to CS4				
EGPRS	Class 12, MCS1 to MCS9				
GSM Class	Small MS				
Static Receiver input Sensitivity @ ARP	GSM 850 / E-GSM 900	-102	-111		dBm
	GSM 1800 / GSM 1900	-102	-110		dBm
RF Power @ ARP with 50Ω Load GSM	GSM 850 / E-GSM 900		33		dBm
	GSM 1800 / GSM 1900		30		dBm

Table 34: RF Antenna interface GSM/UMTS/LTE (at operating temperature range¹)

Parameter		Conditions	Min.	Typical	Max.	Unit
RF Power @ ARP with 50Ω Load (ROPR=4, i.e., no reduction)	GPRS, 1 TX	GSM 850 / E-GSM 900		33		dBm
		GSM 1800 / GSM 1900		30		dBm
	EDGE, 1 TX	GSM 850 / E-GSM 900		27		dBm
		GSM 1800 / GSM 1900		26		dBm
	GPRS, 2 TX	GSM 850 / E-GSM 900		33		dBm
		GSM 1800 / GSM 1900		30		dBm
	EDGE, 2 TX	GSM 850 / E-GSM 900		27		dBm
		GSM 1800 / GSM 1900		26		dBm
	GPRS, 3 TX	GSM 850 / E-GSM 900		33		dBm
		GSM 1800 / GSM 1900		30		dBm
	EDGE, 3 TX	GSM 850 / E-GSM 900		27		dBm
		GSM 1800 / GSM 1900		26		dBm
	GPRS, 4 TX	GSM 850 / E-GSM 900		33		dBm
		GSM 1800 / GSM 1900		30		dBm
	EDGE, 4 TX	GSM 850 / E-GSM 900		27		dBm
		GSM 1800 / GSM 1900		26		dBm
RF Power @ ARP with 50Ω Load (ROPR=5)	GPRS, 1 TX	GSM 850 / E-GSM 900		33		dBm
		GSM 1800 / GSM 1900		30		dBm
	EDGE, 1 TX	GSM 850 / E-GSM 900		27		dBm
		GSM 1800 / GSM 1900		26		dBm
	GPRS, 2 TX	GSM 850 / E-GSM 900		33		dBm
		GSM 1800 / GSM 1900		30		dBm
	EDGE, 2 TX	GSM 850 / E-GSM 900		27		dBm
		GSM 1800 / GSM 1900		26		dBm
	GPRS, 3 TX	GSM 850 / E-GSM 900		32.2		dBm
		GSM 1800 / GSM 1900		29.2		dBm
	EDGE, 3 TX	GSM 850 / E-GSM 900		27		dBm
		GSM 1800 / GSM 1900		26		dBm
	GPRS, 4 TX	GSM 850 / E-GSM 900		31		dBm
		GSM 1800 / GSM 1900		28		dBm
	EDGE, 4 TX	GSM 850 / E-GSM 900		27		dBm
		GSM 1800 / GSM 1900		26		dBm

Table 34: RF Antenna interface GSM/UMTS/LTE (at operating temperature range¹)

Parameter		Conditions	Min.	Typical	Max.	Unit
RF Power @ ARP with 50Ω Load (ROPR=6)	GPRS, 1 TX	GSM 850 / E-GSM 900		33		dBm
		GSM 1800 / GSM 1900		30		dBm
	EDGE, 1 TX	GSM 850 / E-GSM 900		27		dBm
		GSM 1800 / GSM 1900		26		dBm
	GPRS, 2 TX	GSM 850 / E-GSM 900		31		dBm
		GSM 1800 / GSM 1900		28		dBm
	EDGE, 2 TX	GSM 850 / E-GSM 900		27		dBm
		GSM 1800 / GSM 1900		26		dBm
	GPRS, 3 TX	GSM 850 / E-GSM 900		30.2		dBm
		GSM 1800 / GSM 1900		27.2		dBm
	EDGE, 3 TX	GSM 850 / E-GSM 900		27		dBm
		GSM 1800 / GSM 1900		26		dBm
	GPRS, 4 TX	GSM 850 / E-GSM 900		29		dBm
		GSM 1800 / GSM 1900		26		dBm
	EDGE, 4 TX	GSM 850 / E-GSM 900		27		dBm
		GSM 1800 / GSM 1900		26		dBm
RF Power @ ARP with 50Ω Load (ROPR=7)	GPRS, 1 TX	GSM 850 / E-GSM 900		33		dBm
		GSM 1800 / GSM 1900		30		dBm
	EDGE, 1 TX	GSM 850 / E-GSM 900		27		dBm
		GSM 1800 / GSM 1900		26		dBm
	GPRS, 2 TX	GSM 850 / E-GSM 900		30		dBm
		GSM 1800 / GSM 1900		27		dBm
	EDGE, 2 TX	GSM 850 / E-GSM 900		27		dBm
		GSM 1800 / GSM 1900		26		dBm
	GPRS, 3 TX	GSM 850 / E-GSM 900		28.2		dBm
		GSM 1800 / GSM 1900		25.2		dBm
	EDGE, 3 TX	GSM 850 / E-GSM 900		27		dBm
		GSM 1800 / GSM 1900		26		dBm
	GPRS, 4 TX	GSM 850 / E-GSM 900		27		dBm
		GSM 1800 / GSM 1900		24		dBm
	EDGE, 4 TX	GSM 850 / E-GSM 900		27		dBm
		GSM 1800 / GSM 1900		26		dBm

Table 34: RF Antenna interface GSM/UMTS/LTE (at operating temperature range¹)

Parameter		Conditions	Min.	Typical	Max.	Unit
RF Power @ ARP with 50Ω Load (ROPR=8, i.e., max. reduction)	GPRS, 1 TX	GSM 850 / E-GSM 900		33		dBm
		GSM 1800 / GSM 1900		30		dBm
	EDGE, 1 TX	GSM 850 / E-GSM 900		27		dBm
		GSM 1800 / GSM 1900		26		dBm
	GPRS, 2 TX	GSM 850 / E-GSM 900		30		dBm
		GSM 1800 / GSM 1900		27		dBm
	EDGE, 2 TX	GSM 850 / E-GSM 900		24		dBm
		GSM 1800 / GSM 1900		23		dBm
	GPRS, 3 TX	GSM 850 / E-GSM 900		28.2		dBm
		GSM 1800 / GSM 1900		25.2		dBm
	EDGE, 3 TX	GSM 850 / E-GSM 900		22.2		dBm
		GSM 1800 / GSM 1900		21.2		dBm
	GPRS, 4 TX	GSM 850 / E-GSM 900		27		dBm
		GSM 1800 / GSM 1900		24		dBm
	EDGE, 4 TX	GSM 850 / E-GSM 900		21		dBm
		GSM 1800 / GSM 1900		20		dBm

¹ At restricted temperature range no active power reduction is implemented - any deviations are hardware related.

² Applies also to UMTS/LTE Rx diversity/MIMO antenna.

6.9. GNSS Interface Characteristics

The following tables list general characteristics of the GNSS interface.

Table 35: GNSS properties

Parameter	Conditions	Min.	Typical	Max.	Unit
Frequency	GPS GLONASS Galileo	1597.551	1575.42 1575.42	1605.886	MHz
Tracking Sensitivity	Open sky Active antenna or LNA Passive antenna		-159 -156		dBm
Acquisition Sensitivity	Open sky Active antenna or LNA Passive antenna		-149 -145		dBm
Cold Start sensitivity ¹			-145		dBm
Time-to-First-Fix (TTFF) ²	Cold ³		25	32	s
	Warm ⁴		10	29	s

¹ Test condition: Assumes 300 seconds timeout, QoS=1000m, and 50% yield.



² Test conditions: TTFF is defined for an open sky environment, i.e., with a clear view to the sky and a minimum signal level of -130dBm at the antenna for at least 3...4 satellites. This signal level represents C/No=42dB in an NMEA \$GPGSV message. Also, the DR_SYNC line needs to be enabled using the AT command: AT^SGP-SC="Nmea/DRSync","on"

³ For test purposes a cold start may be triggered by AT command: AT^SBNW="agps",-1 - see also [1]

⁴ To optimize GPS start-up behavior, it is recommended to backup the module's internal real time clock via VD-DLP line as described in Section 3.5..

Through the external GNSS antenna DC feeding the module is able to supply an active GNSS antenna. The supply voltage level at the GNSS antenna interface depends on the GNSS configuration done with AT command as shown in Table 36.

Table 36: Power supply for active GNSS antenna

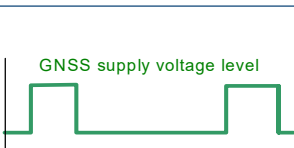
Function	Setting samples	IO	Signal form and level
GNSS active antenna supply	Supply voltage with: GNSS receiver off Active antenna off	O	
	Supply voltage with: GNSS receiver on Active antenna on SLEEP mode	O	
	Supply voltage with: GNSS receiver on Active antenna auto	O	

6.10. Electrostatic Discharge

The module is not protected against Electrostatic Discharge (ESD) in general. Consequently, it is subject to ESD handling precautions that typically apply to ESD sensitive components. Proper ESD handling and packaging procedures must be applied throughout the processing, handling and operation of any application that incorporates a ALS3-US R4 module.

Special ESD protection provided on ALS3-US R4:

BATT+: Inductor/capacitor

An example for an enhanced ESD protection for the SIM interface is shown in [Section 3.8.1.](#)

The remaining interfaces of ALS3-US R4 with the exception of the antenna interface are not accessible to the user of the final product (since they are installed within the device) and are therefore only protected according to the ANSI/ESDA/ JEDEC JS-001-2011 requirements.

ALS3-US R4 has been tested according to the following standards. Electrostatic values can be gathered from the following table.

Table 37: Electrostatic values

Specification / Requirements	Contact discharge	Air discharge
<i>ANSI/ESDA/JEDEC JS-001-2011</i>		
All SMT interfaces	± 1kV Human Body Model	n.a.
<i>JESD22-C101-F (Class C1)</i>		
All SMT interfaces	± 250V Charged Device Model (CDM)	n.a.
<i>ETSI EN 301 489-1/7</i>		
BATT+	± 4kV	± 8kV

Note: The values may vary with the individual application design. For example, it matters whether or not the application platform is grounded over external devices like a computer or other equipment, such as the Kontron reference application described in [Chapter 9/](#).

7/ Mechanics, Mounting and Packaging

7.1. Mechanical Dimensions of ALS3-US R4

Figure 46 shows a 3D view¹ of ALS3-US R4 and provides an overview of the board's mechanical dimensions. For further details see Figure 47.

Length: 33mm
Width: 29mm
Height: 2.2mm

Figure 46: ALS3-US R4 – top and bottom view

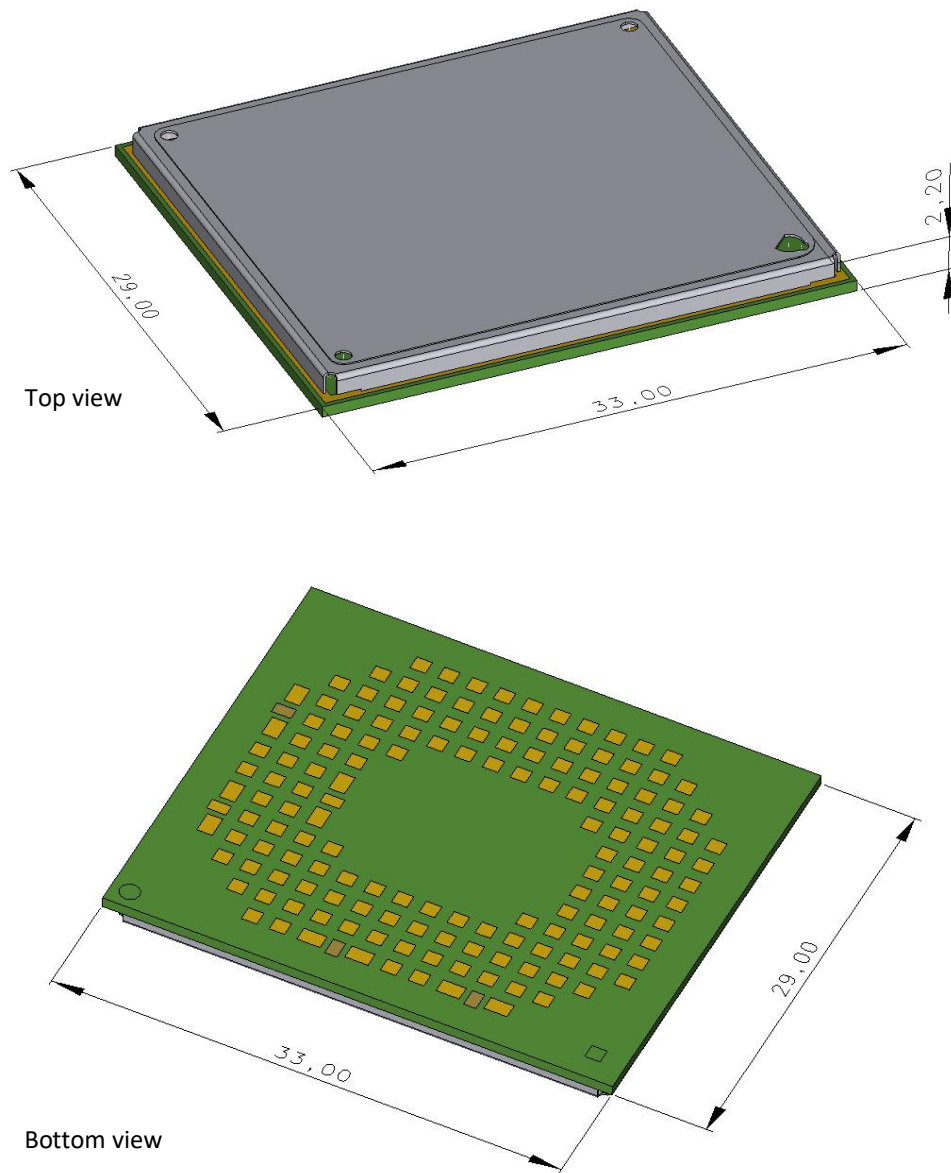

¹ The coloring of the 3D view does not reflect the module's real color.

7.2. Mounting ALS3-US R4 onto the Application Platform

This section describes how to mount ALS3-US R4 onto the PCBs, including land pattern and stencil design, board-level characterization, soldering conditions, durability and mechanical handling. For more information on issues related to SMT module integration see also [3].

Note: Kontron strongly recommends to solder all connecting pads for mechanical stability and heat dissipation. Not only must all supply pads and signals be connected appropriately, but all pads denoted as “Do not use” should also be soldered (but not electrically connected). Note also that in order to avoid short circuits between signal tracks on an external application's PCB and various markings at the bottom side of the module, it is recommended not to route the signal tracks on the top layer of an external PCB directly under the module, or at least to ensure that signal track routes are sufficiently covered with solder resist.

7.2.1. SMT PCB Assembly

7.2.1.1. Land Pattern and Stencil

The land pattern and stencil design as shown below is based on Kontron characterizations for lead-free solder paste on a four-layer test PCB and a 110 as well as a 150 micron-thick stencil.

The land pattern given in Figure 48 reflects the module's pad layout, including signal pads and ground pads (for pad assignment see Section 6.5.). Besides these pads there are ground areas on the module's bottom side that must not be soldered, e.g., the position marker. To prevent short circuits, it has to be ensured that there are no wires on the external application side that may connect to these module ground areas.

Figure 48: Land pattern (top layer)

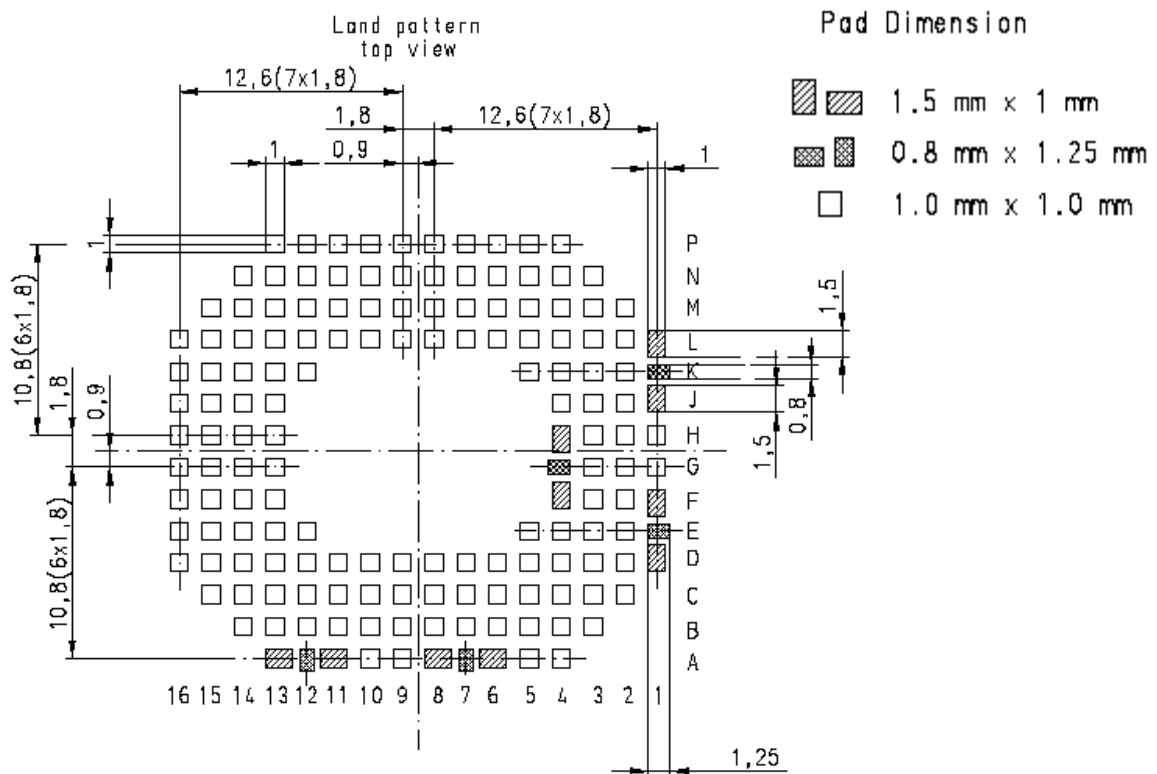

The stencil design illustrated in Figure 49 and Figure 50 is recommended by Kontron as a result of extensive tests with Kontron Daisy Chain modules.

Figure 49: Recommended design for 110 micron thick stencil (top layer)

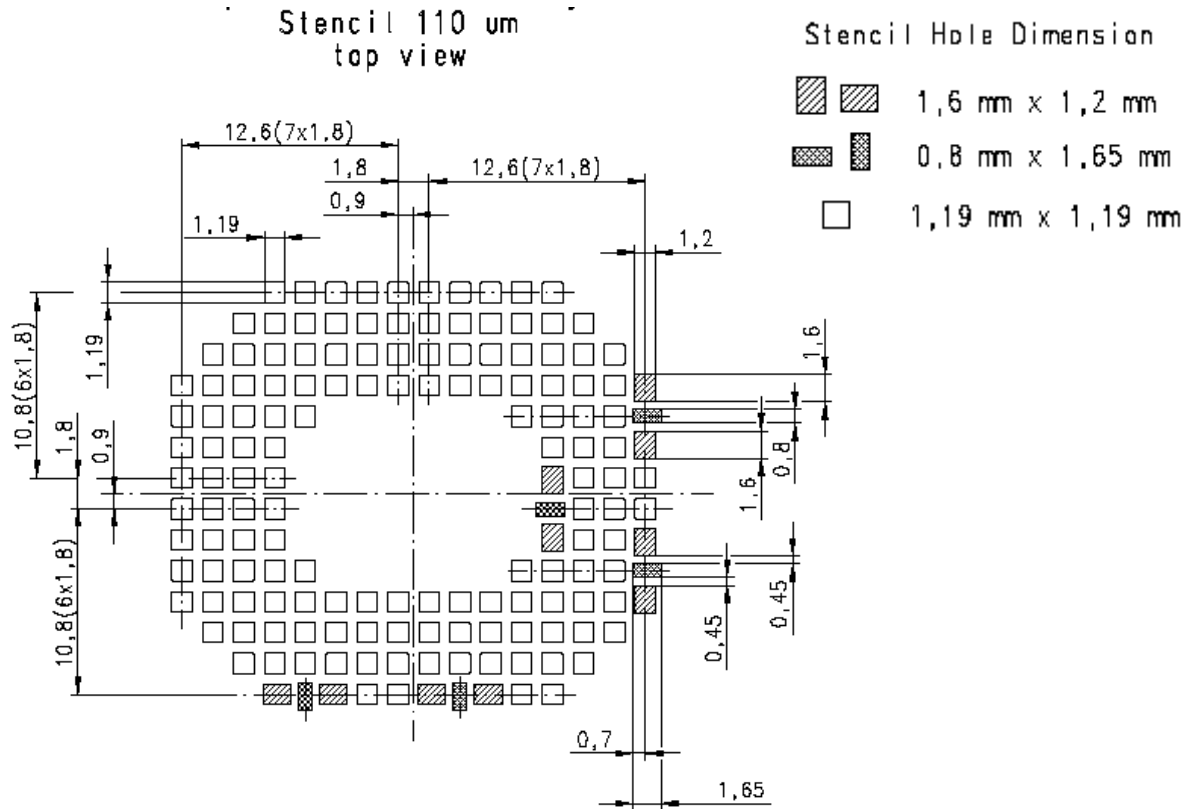
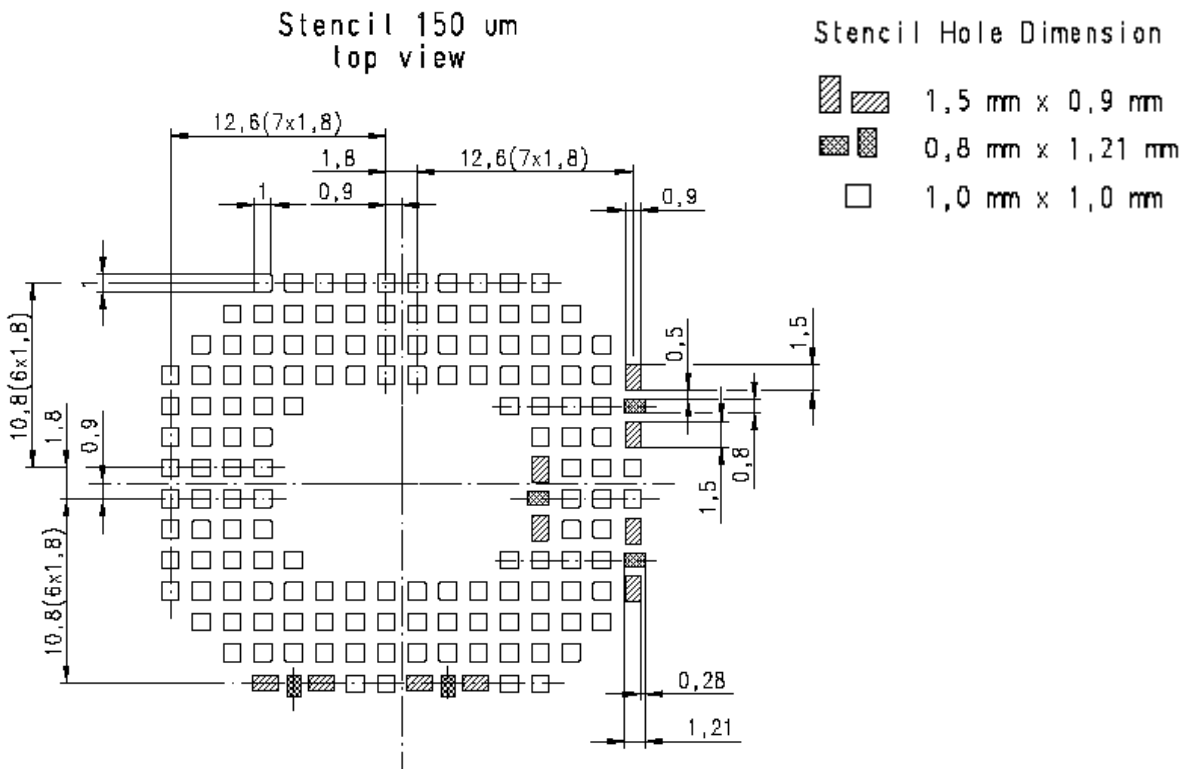

Figure 50: Recommended design for 150 micron thick stencil (top layer)



7.2.1.2. Board Level Characterization

Board level characterization issues should also be taken into account if devising an SMT process.

Characterization tests should attempt to optimize the SMT process with regard to board level reliability. This can be done by performing the following physical tests on sample boards: Peel test, bend test, tensile pull test, drop shock test and temperature cycling. Sample surface mount checks are described in [3].

It is recommended to characterize land patterns before an actual PCB production, taking individual processes, materials, equipment, stencil design, and reflow profile into account. For land and stencil pattern design recommendations see also Section 7.2.1.1.. Optimizing the solder stencil pattern design and print process is necessary to ensure print uniformity, to decrease solder voids, and to increase board level reliability.

Daisy chain modules for SMT characterization are available on request. For details refer to [3].

Generally, solder paste manufacturer recommendations for screen printing process parameters and reflow profile conditions should be followed. Maximum ratings are described in Section 7.2.3..

7.2.2. Moisture Sensitivity Level

ALS3-US R4 comprises components that are susceptible to damage induced by absorbed moisture.

Kontron' ALS3-US R4 module complies with the latest revision of the IPC/JEDEC J-STD-020 Standard for moisture sensitive surface mount devices and is classified as MSL 4.

For additional moisture sensitivity level (MSL) related information see Section 7.2.4. and Section 7.3.2..

7.2.3. Soldering Conditions and Temperature

7.2.3.1. Reflow Profile

Figure 51: Reflow Profile

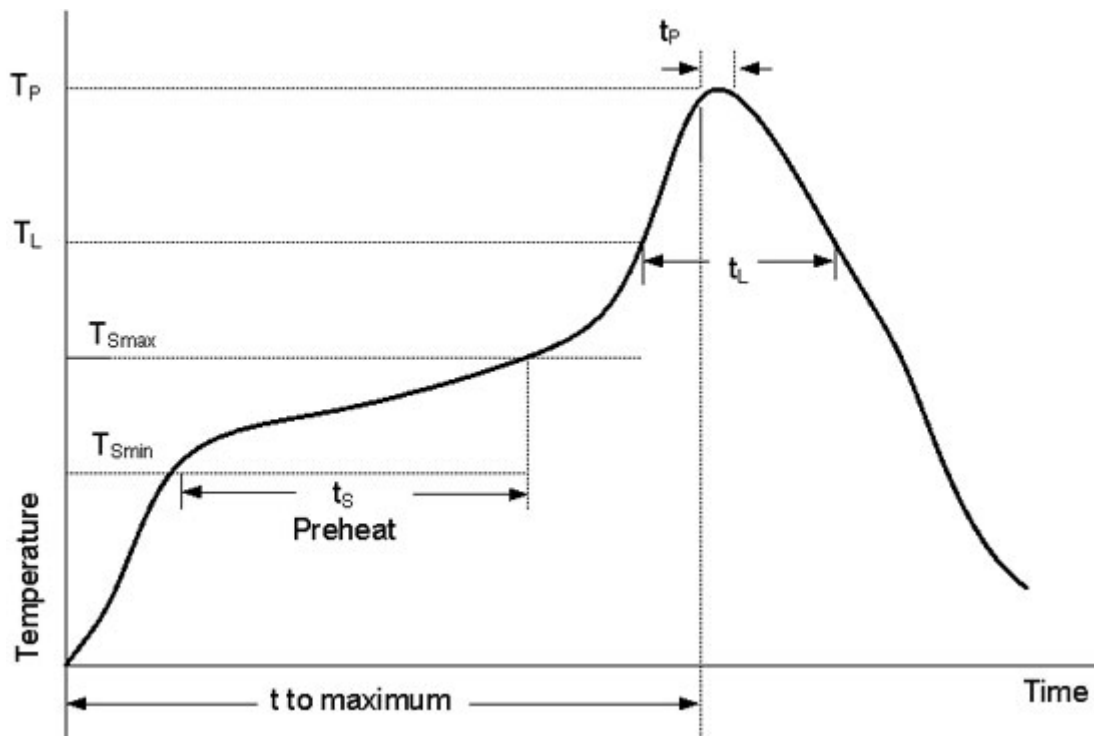
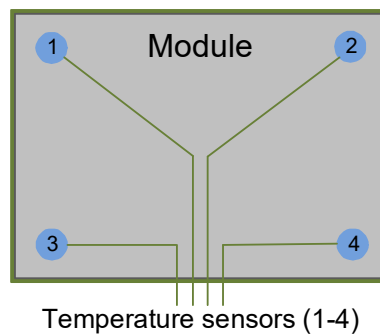

Table 38: Reflow temperature recommendations¹

Profile Feature	Pb-Free Assembly
Preheat & Soak Temperature Minimum (T_{Smin}) Temperature Maximum (T_{Smax}) Time (t_{Smin} to t_{Smax}) (t_s)	150°C 200°C 60-120 seconds
Average ramp up rate (T_L to T_p)	3K/second max. ²
Liquidous temperature (T_L) Time at liquidous (t_L)	217°C 60-90 seconds
Peak package body temperature (T_p)	245°C +0/-5°C
Time (t_p) within 5 °C of the peak package body temperature (T_p)	30 seconds max.
Limited ramp-down rate ($T_p - 200^\circ\text{C}$) Average ramp-down rate from 200°C	1K/second max. ² 3K-6K/second max. ²
Time 25°C to maximum temperature	8 minutes max.

¹ Please note that the listed reflow profile features and ratings are based on the joint industry standard IPC/JEDEC J-STD-020D.1, and are as such meant as a general guideline. For more information on reflow profiles and their optimization please refer to [3].

² Temperatures measured on shielding at each corner. See also [3].



7.2.3.2. Maximum Temperature and Duration

The following limits are recommended for the SMT board-level soldering process to attach the module:

- › A maximum module temperature of 245°C. This specifies the temperature as measured at the module's top side.
- › A maximum duration of 30 seconds at this temperature.
- › Ramp-down rate from T_p to 200°C should be controlled in order to reduce thermally induced stress during the solder solidification phase (see Table 38 - limited ramp-down rate). Therefore, a cool-down step in the oven's temperature program between 200°C and 180°C should be considered. For more information on reflow profiles and their optimization see [3].

Please note that while the solder paste manufacturers' recommendations for best temperature and duration for solder reflow should generally be followed, the limits listed above must not be exceeded.

ALS3-US R4 is specified for one soldering cycle only. Once ALS3-US R4 is removed from the application, the module will very likely be destroyed and cannot be soldered onto another application.

7.2.4. Durability and Mechanical Handling

7.2.4.1. Storage Life

ALS3-US R4 modules, as delivered in tape and reel carriers, must be stored in sealed, moisture barrier anti-static bags. The shelf life in a sealed moisture bag is an estimated 12 months. However, such a life span requires a non-condensing atmospheric environment, ambient temperatures below 40°C and a relative humidity below 90%. Additional storage conditions are listed in [Table 27](#).

7.2.4.2. Processing Life

ALS3-US R4 must be soldered to an application within 72 hours after opening the moisture barrier bag (MBB) it was stored in.

As specified in the IPC/JEDEC J-STD-033 Standard, the manufacturing site processing the modules should have ambient temperatures below 30°C and a relative humidity below 60%.

7.2.4.3. Baking

Baking conditions are specified on the moisture sensitivity label attached to each MBB (see [Figure 56](#) for details):

- › It is *not necessary* to bake ALS3-US R4, if the conditions specified in [Section 7.2.4.1.](#) and [Section 7.2.4.2.](#) were not exceeded.
- › It is *necessary* to bake ALS3-US R4, if any condition specified in [Section 7.2.4.1.](#) and [Section 7.2.4.2.](#) was exceeded.

If baking is necessary, the modules must be put into trays that can be baked to at least 125°C. Devices should not be baked in tape and reel carriers at any temperature.

7.2.4.4. Electrostatic Discharge

Electrostatic discharge (ESD) may lead to irreversible damage for the module. It is therefore advisable to develop measures and methods to counter ESD and to use these to control the electrostatic environment at manufacturing sites.

Please refer to [Section 6.10.](#) for further information on electrostatic discharge.

7.3. Packaging

7.3.1. Tape and Reel

The single-feed tape carrier for ALS3-US R4 is illustrated in Figure 52. The figure also shows the proper part orientation. The tape width is 44mm and the ALS3-US R4 modules are placed on the tape with a 40mm pitch. The reels' outer diameter is 330mm. For further information on the number of modules per reel and tape as well as the minimum order quantity (MoQ) please contact Kontron.

7.3.1.1. Orientation

Figure 52: Carrier tape

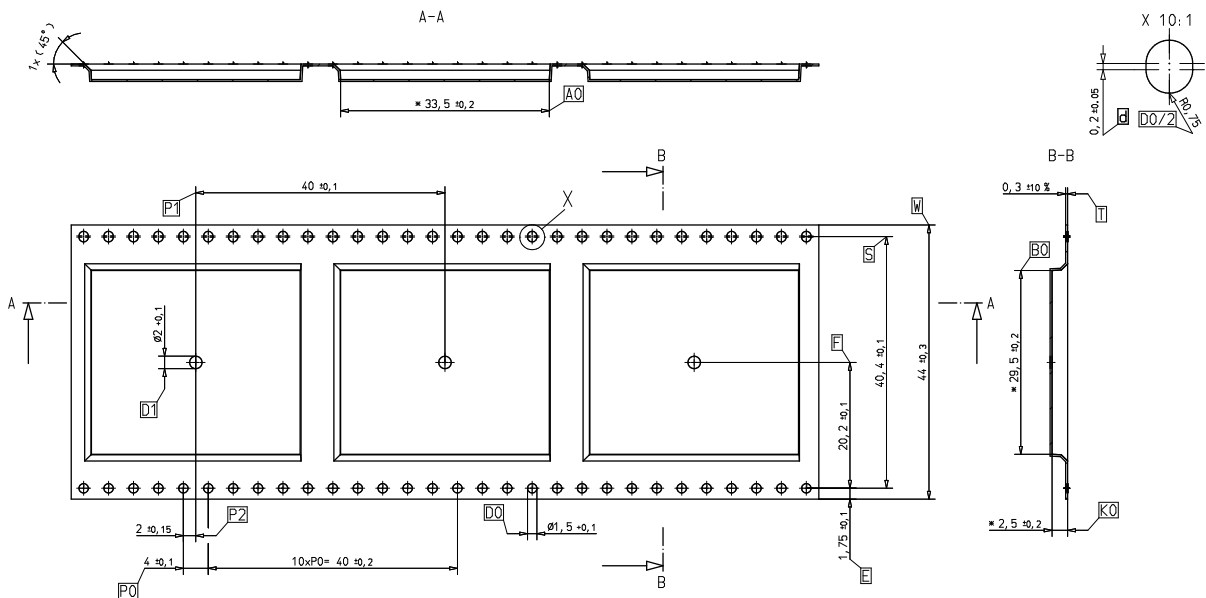
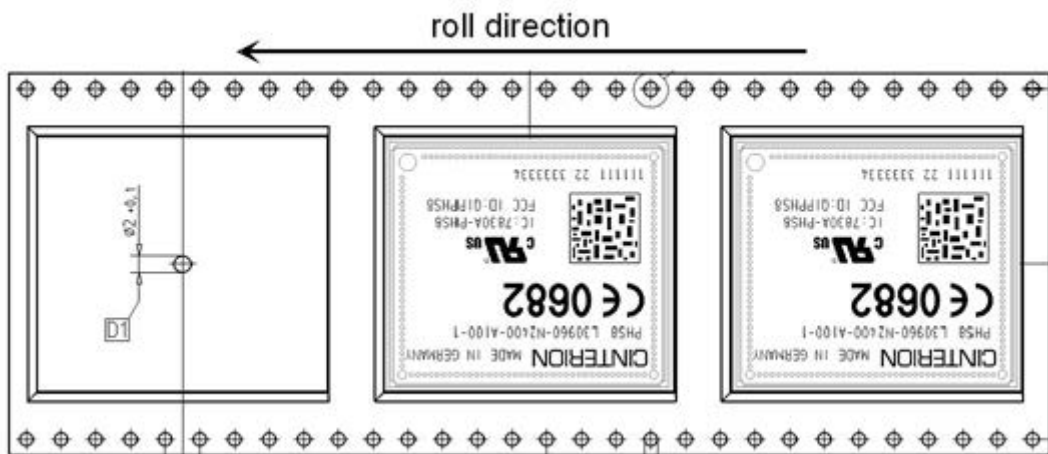

Figure 53: Roll direction



7.3.1.2. Barcode Label

A barcode label provides detailed information on the tape and its contents. It is attached to the reel.

Figure 54: Barcode label on tape reel

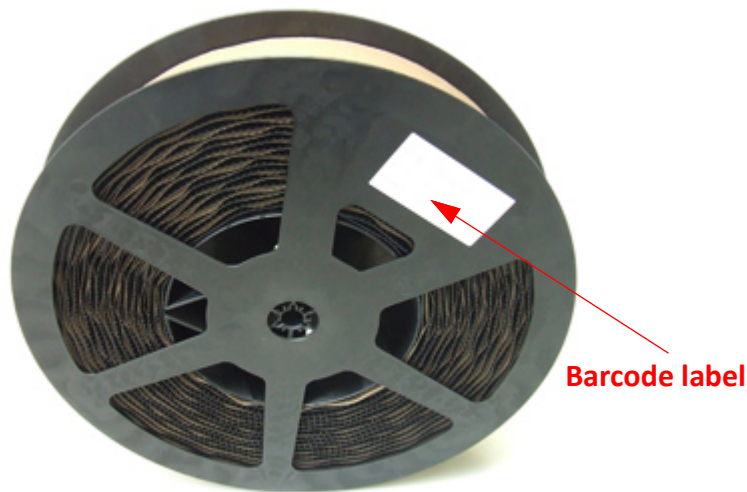

7.3.2. Shipping Materials

ALS3-US R4 is distributed in tape and reel carriers. The tape and reel carriers used to distribute ALS3-US R4 are packed as described below, including the following required shipping materials:

- › Moisture barrier bag, including desiccant and humidity indicator card
- › Transportation bag

7.3.2.1. Moisture Barrier Bag

The tape reels are stored inside a moisture barrier bag (MBB), together with a humidity indicator card and desiccant pouches - see [Figure 55](#). The bag is ESD protected and delimits moisture transmission. It is vacuum-sealed and should be handled carefully to avoid puncturing or tearing. The bag protects the ALS3-US R4 modules from moisture exposure. It should not be opened until the devices are ready to be soldered onto the application.

Figure 55: Moisture barrier bag (MBB) with imprint

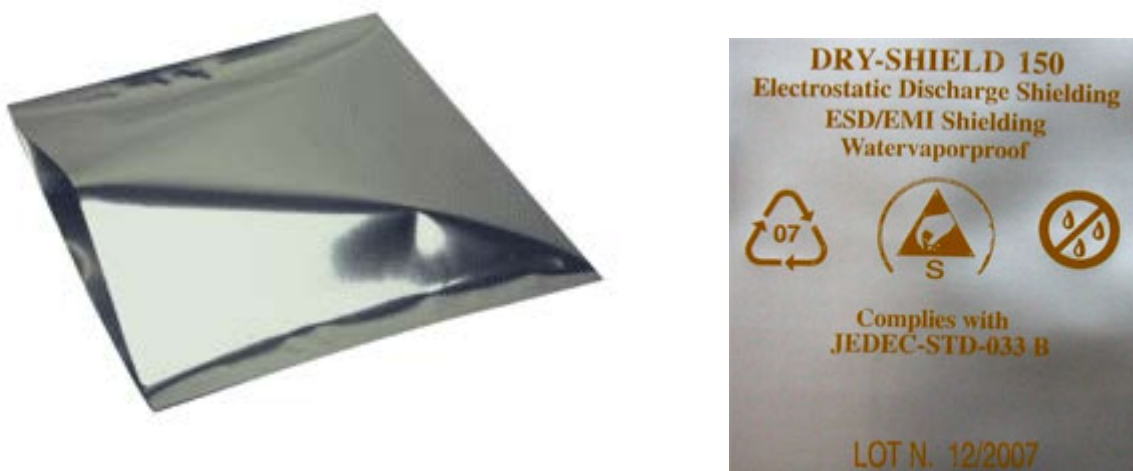

The label shown in Figure 56 summarizes requirements regarding moisture sensitivity, including shelf life and baking requirements. It is attached to the outside of the moisture barrier bag.

Figure 56: Moisture Sensitivity Label



CAUTION

This bag contains

MOISTURE-SENSITIVE DEVICES

LEVEL

4

1. Calculated shelf life in sealed bag:
12 months at < 40 °C and < 90% relative humidity (RH)
2. Peak package body temperature: 245 °C
3. After bag is opened, devices that will be subject to reflow solder or other high temperature process must be
 - a) mounted within: 72 hours of factory conditions < 30 °C / 60% RH
 - b) stored at < 10% RH
4. Devices require bake, before mounting, if
 - a) Humidity Indicator Card is > 10% when read at 23 +/- 5 °C
 - b) 3a or 3b not met
5. If baking is required, refer to IPC/Jedec J-STD-033 for bake procedure
 Note: The devices are shipped in a non heat-resistant carrier and may not be baked in the carriers
6. The maximum guaranteed soldering cycle of the module is limited to 1 cycle

Bag Seal Date: DD.MM.YYYY

Note: MSL level and body temperature defined by IPC/JEDEC J-STD-020

CINTERION

INFO-2
DELIVERYPARTNUMBER

Peak package body temperature: 245°C Qty. : 000

Bag Seal Date (DDMMYYYY) : DDMMYYYY



Package ID: WM8000123412



MBBs contain one or more desiccant pouches to absorb moisture that may be in the bag. The humidity indicator card described below should be used to determine whether the enclosed components have absorbed an excessive amount of moisture.

The desiccant pouches should not be baked or reused once removed from the MBB.

The humidity indicator card is a moisture indicator and is included in the MBB to show the approximate relative humidity level within the bag. A sample humidity card is shown in Figure 57. If the components have been exposed to moisture above the recommended limits, the units will have to be rebaked.

Figure 57: Humidity Indicator Card - HIC

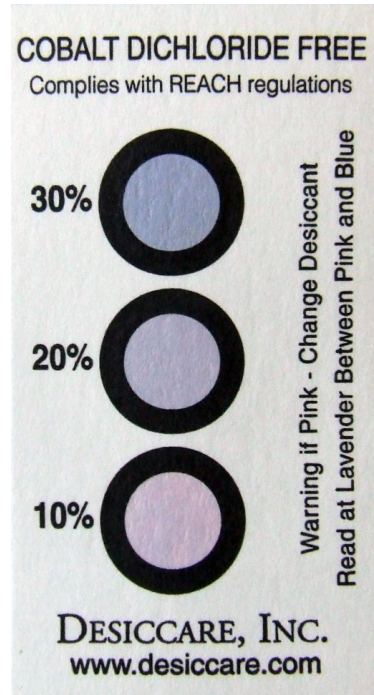

A baking is required if the humidity indicator inside the bag indicates 10% RH or more.

7.3.2.2. Transportation Box

Tape and reel carriers are distributed in a box, marked with a barcode label for identification purposes.

8/ Sample Application

[Figure 58](#) shows a typical example of how to integrate an ALS3-US R4 module with an application.

The audio interface demonstrates the balanced connection of microphone and earpiece. This solution is particularly well suited for internal transducers.

The PWR_IND line is an open collector that needs an external pull-up resistor which connects to the voltage supply VCC μ C of the microcontroller. Low state of the open collector pulls the PWR_IND signal low and indicates that the ALS3-US R4 module is active, high level notifies the Power Down mode.

If the module is in Power Down mode avoid current flowing from any other source into the module circuit, for example reverse current from high state external control lines. Therefore, the controlling application must be designed to prevent reverse flow.

While developing SMT applications it is strongly recommended to provide test points for certain signals, i.e., lines to and from the module - for debug and/or test purposes. The SMT application should allow for an easy access to these signals. For details on how to implement test points see [\[3\]](#).

The EMC measures are best practice recommendations. In fact, an adequate EMC strategy for an individual application is very much determined by the overall layout and, especially, the position of components.

Some LGA pads are connected to clocks or high speed data streams that might interfere with the module's antenna. The RF receiver would then be blocked at certain frequencies (self interference). The external application's PCB tracks connected to these pads should therefore be well shielded or kept away from the antenna. This applies especially to the USB and UICC/SIM interfaces.

Depending on the micro controller used by an external application ALS3-US R4's digital input and output lines may require level conversion. [Section 8.1.](#) shows a possible sample level conversion circuit.

The analog-to-digital converter (ADCx_IN lines) can be used for antenna diagnosis. A sample antenna detection circuit can be found in [Figure 60](#) and [Figure 61](#).

Disclaimer:

No warranty, either stated or implied, is provided on the sample schematic diagram shown in [Figure 58](#) and the information detailed in this section. As functionality and compliance with national regulations depend to a great amount on the used electronic components and the individual application layout manufacturers are required to ensure adequate design and operating safeguards for their products using ALS3-US R4 modules.

Figure 58: ALS3-US R4 sample application

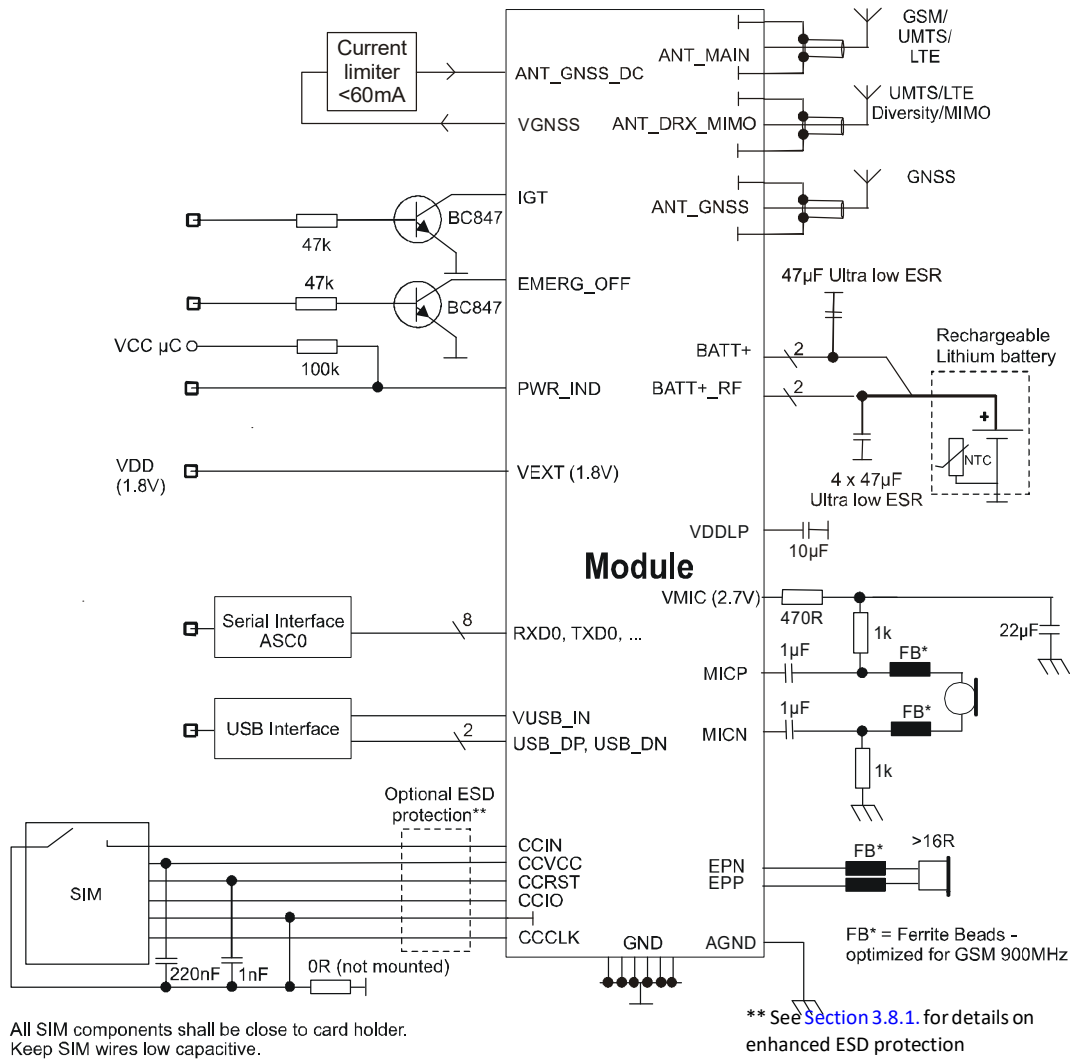

All SIM components shall be close to card holder.
Keep SIM wires low capacitive.

8.1. Sample Level Conversion Circuit

Depending on the micro controller used by an external application ALS3-US R4's digital input and output lines (i.e., ASCO lines) may require level conversion. The following [Figure 59](#) shows a sample circuit with recommended level shifters for an external application's micro controller (with VLOGIC between 3.0V...3.6V). The level shifters can be used for digital input and output lines with $V_{OHmax}=1.85V$ or $V_{IHmax}=1.85V$.

Figure 59: Sample level conversion circuit

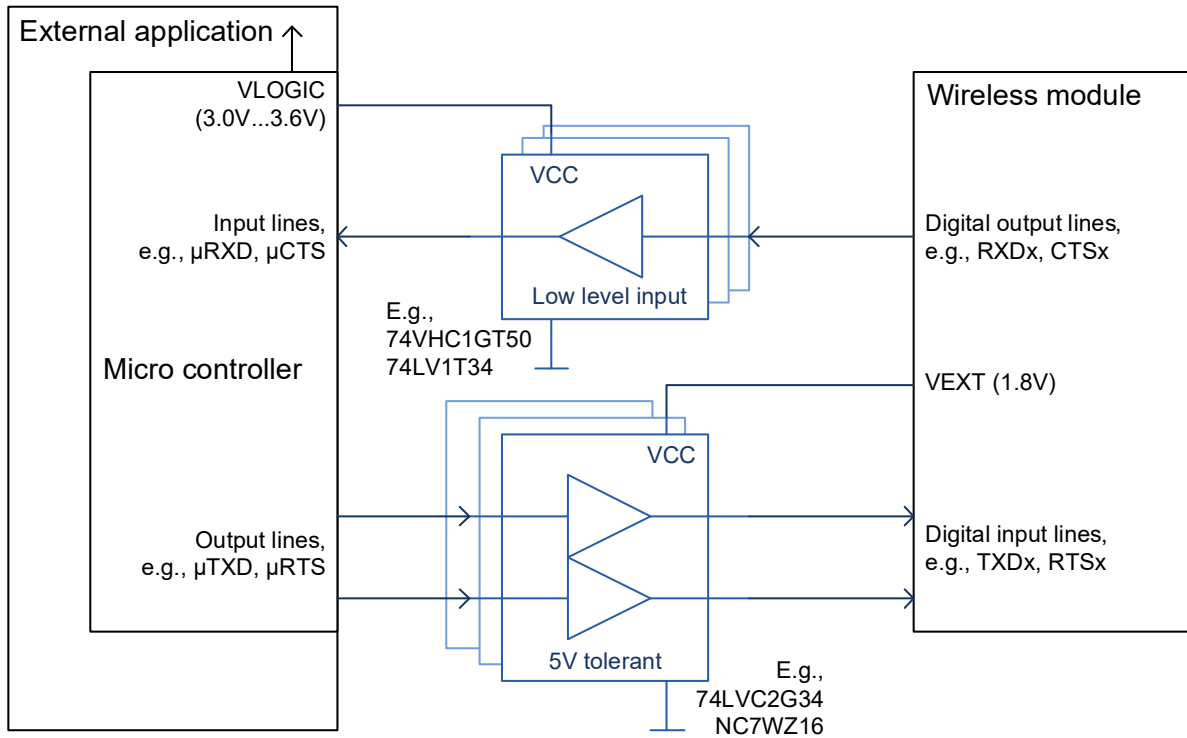

8.2. Sample Circuit for Antenna Detection

The following figures explain how an RF antenna detection circuit may be implemented for ALS3-US R4 to be able to detect 1 or 2 antennas (for basic circuit and diagnostic principles - including usage of GPIO and ADCx_IN pads - please refer to Section 5.1.4.). Figure 60 gives a general overview, Figure 61 depicts the actual antenna detection layout and shows how ESD protection, i.e., an RF/DC bridge will have to be handled. The switch driver and antenna switch mentioned in Figure 60 will have to be realized by the application manufacturer.

Properties for the components mentioned in Figure 60 and Figure 61 are given in Table 39 - parts list.

Figure 60: Antenna diagnosis - overview

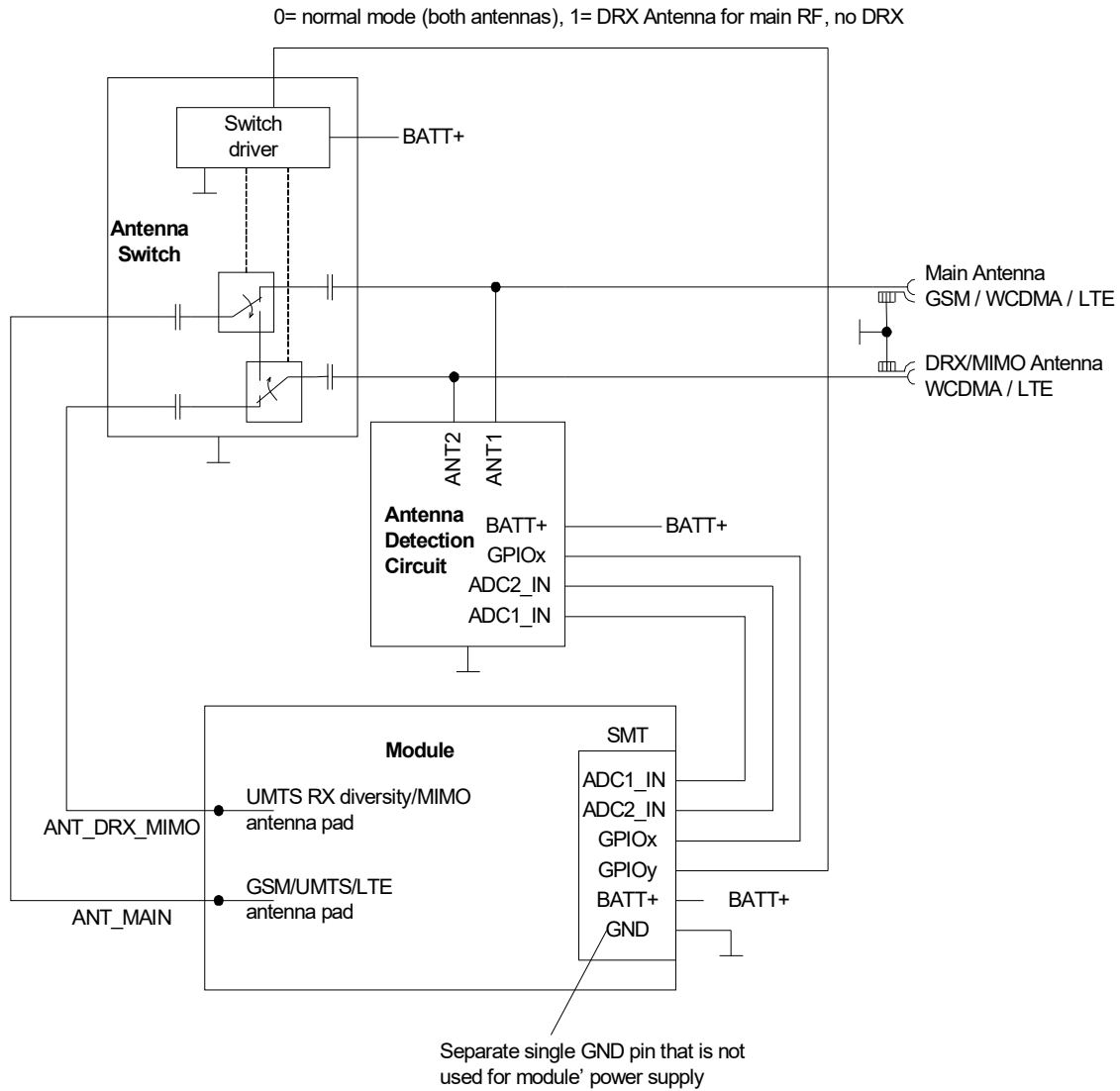

Figure 61: Antenna diagnosis - antenna detection schematic

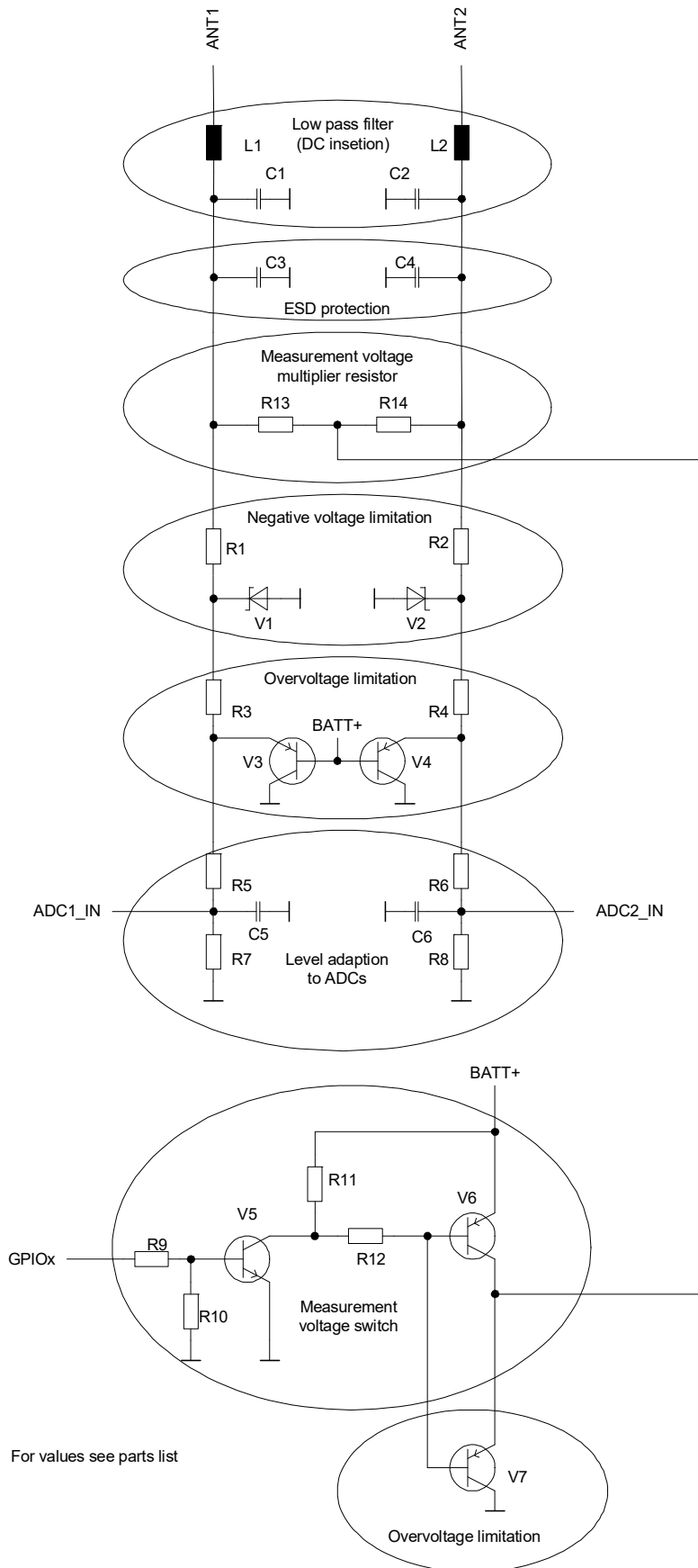

Table 39: Antenna diagnosis reference circuit - parts list

Reference	Part	Value	Tolerance	Conditions	Size
R1,2	Resistor	22R			
R3,4	Resistor	10k		$\geq 125\text{mW}$	
R5,6	Resistor	140k	1%		
R7,8	Resistor	100k	1%		
R9,10	Resistor	100k			
R11,12	Resistor	10k		$\geq 125\text{mW}$	
R13,14	Resistor	4k4 (e.g., 2x2k2 or 4x1k1)	1%	$\geq 300\text{mW}$	
C1,2	Capacitor	22p		50V	≤ 0402
C3,4	Capacitor	100n		50V	
C5,6	Capacitor	100n		10V	
V1,2	Schottky diode	RB520-40		40V	
V3,4,6,7	Transistor	BC857			
V5	Transistor	BC847			
L1,2	Inductor	39nH		Wire wound High Q	0402

9/ Reference Approval

9.1. Reference Equipment for Type Approval

The Kontron reference setup submitted to type approve ALS3-US R4 is shown in [Figure 62](#). The module (i.e., the evaluation module) is connected to the DSB75 by means of a flex cable and a special DSB75 adapter. The GSM/UMTS/LTE test equipment is connected via edge mount SMA connectors soldered to the module's antenna pads.

For ESD tests and evaluation purposes, it is also possible connect the module to the GSM/UMTS/LTE test equipment through an SMA-to-Hirose-U.FL antenna cable and the SMA antenna connectors of the DSB75 adapter.

A further option is to mount the evaluation module directly onto the DSB75 adapter's 80-pin board-to-board connector and to connect the test equipment as shown below.

Figure 62: Reference equipment for type approval

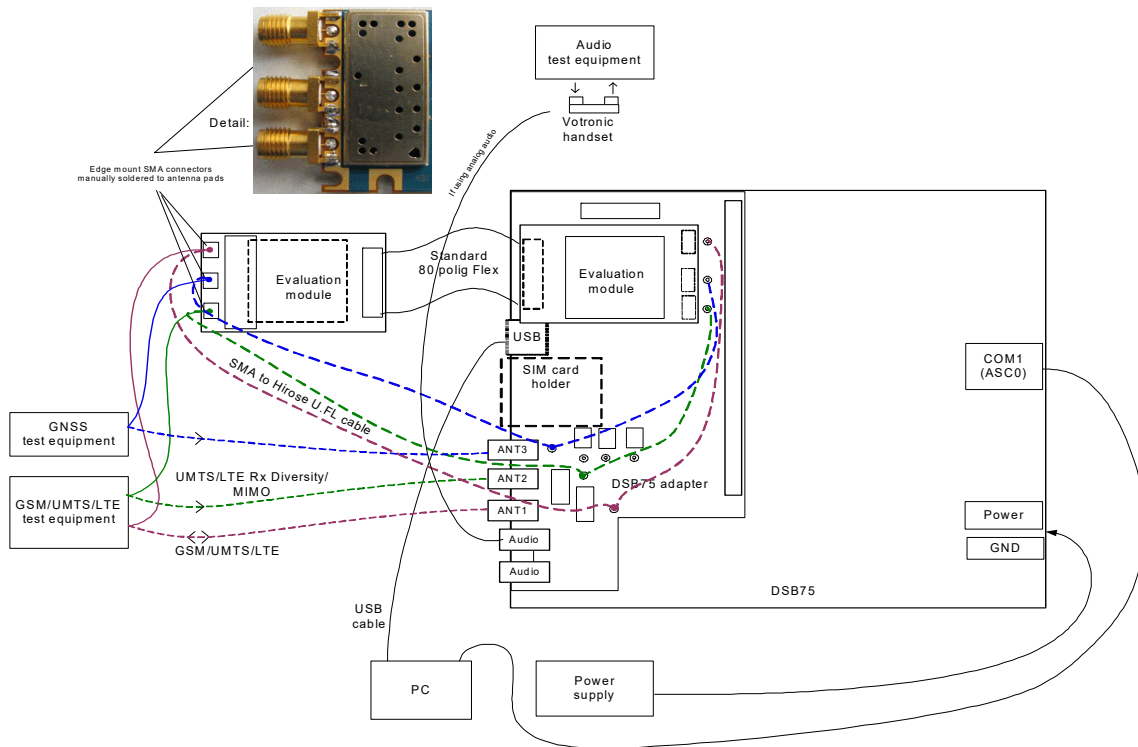

9.2. Compliance with FCC and ISED Rules and Regulations

The Equipment Authorization Certification for the Kontron modules reference application described in [Section 9.1](#). will be registered under the following identifiers:

- › ALS3-US R4:
FCC Identifier: 2AATHALS3-USR4
ISED Certification Number: 9927C-ALS3USR4
Granted to Kontron Europe GmbH

Note¹: Manufacturers of mobile or fixed devices incorporating ALS3-US R4 modules are authorized to use the FCC Grants and ISED Certificates of the ALS3-US R4 modules for their own final products according to the conditions referenced in these documents. In this case, the FCC label of the module shall be visible from the outside, or the host device shall bear a second label stating "Contains FCC ID: 2AATHALS3-USR4" and accordingly "Contains IC: 9927C-ALS3USR4". The integration is limited to fixed or mobile categorized host devices, where a separation distance between the antenna and any person of min. 20cm can be assured during normal operating conditions.

For mobile and fixed operation configurations the antenna gain, including cable loss, must not exceed the limits listed in the following [Table 40](#) for FCC and IC.

Table 40: Antenna gain limits for FCC and ISED

Operating band	FCC limit	ISED limit	Unit
Maximum gain in lower operating bands with f< 1GHz (GSM850, WCDMA BdV, LTE Bd5 / Bd17)	3.25	0.18	dBi
Maximum gain in higher operating bands with f=1700MHz (WCDMA BdIV, LTE Bd4)	5.5	5.5	dBi
Maximum gain in higher operating bands with f=1900MHz (GSM1900, WCDMA BdII, LTE Band 2)	2.51	2.51	dBi

IMPORTANT:

Manufacturers of portable applications incorporating ALS3-US R4 modules are required to have their final product certified and apply for their own FCC Grant and ISED Certificate related to the specific portable mobile. This is mandatory to meet the SAR requirements for portable mobiles (see [Section 1.4](#). for detail). The final product still requires FCC Part 15 Subpart B compliance testing with the modular transmitter installed. The final product with an embedded module may also need to pass the FCC Part 15 unintentional emission testing requirements, and be properly authorized per FCC Part 15.

Changes or modifications not expressly approved by the party responsible for compliance could void the user's authority to operate the equipment.

Note: This equipment has been tested and found to comply with the limits for a Class B digital device, pursuant to part 15 of the FCC Rules and with Canadian ICES-003 and RSS-210 standards. Operation is subject to the following two conditions: (1) this device may not cause interference, and (2) this device must accept any interference, including interference that may cause undesired operation of the device. These limits are designed to provide reasonable protection against harmful interference in a residential installation. This equipment generates, uses and can radiate radio frequency energy and, if not installed and used in accordance with the instructions, may cause harmful interference to radio communications. However, there is no guarantee that interference will not occur in a particular installation. If this equipment does cause harmful interference to radio or television reception, which can be determined by turning the equipment off and on, the user is encouraged to try to correct the interference by one or more of the following measures:

- › Reorient or relocate the receiving antenna.
- › Increase the separation between the equipment and receiver.
- › Connect the equipment into an outlet on a circuit different from that to which the receiver is connected.
- › Consult the dealer or an experienced radio/TV technician for help.

¹. Label note in French for ISED: Les fabricants d'équipement mobile ou fixe intégrant le module ALS3-US R4 sont autorisés à utiliser les accords FCC et certificats d'Innovation, Sciences et Développement économique Canada (ISED) du module ALS3-US R4 pour leur propre produit final suivant les conditions référencées dans ces documents. Dans ce cas, le label FCC du module doit être visible de l'extérieur, sinon l'équipement hôte doit disposer d'un second label avec la déclaration suivante " Contains FCC ID: 2AATHALS3-USR4", et en conséquence " Contains IC: 9927C-ALS3USR4". L'intégration est limitée aux catégories d'équipement hôte mobile ou fixe, respectant une distance minimum de 20 centimètres entre l'antenne et toute personne avoisinante pour des conditions d'utilisation normale.

If Canadian approval is requested for devices incorporating ALS3-US R4 modules the above note will have to be provided in the English and French language in the final user documentation. Manufacturers/OEM Integrators must ensure that the final user documentation does not contain any information on how to install or remove the module from the final product.

Notes (ISED):

(EN) This Class B digital apparatus complies with Canadian ICES-003 and RSS-210. Operation is subject to the following two conditions: (1) this device may not cause interference, and (2) this device must accept any interference, including interference that may cause undesired operation of the device.

(FR) Cet appareil numérique de classe B est conforme aux normes canadiennes ICES-003 et RSS-210. Son fonctionnement est soumis aux deux conditions suivantes: (1) cet appareil ne doit pas causer d'interférence et (2) cet appareil doit accepter toute interférence, notamment les interférences qui peuvent affecter son fonctionnement.

(EN) Radio frequency (RF) Exposure Information

The radiated output power of the Wireless Device is below the ISED radio frequency exposure limits. The Wireless Device should be used in such a manner such that the potential for human contact during normal operation is minimized. This device has also been evaluated and shown compliant with the ISED RF Exposure limits under mobile exposure conditions. (antennas are greater than 20cm from a person's body).

(FR) Informations concernant l'exposition aux fréquences radio (RF)

La puissance de sortie émise par l'appareil de sans fil est inférieure à la limite d'exposition aux fréquences radio d'Innovation, Sciences et Développement économique Canada (ISDE). Utilisez l'appareil de sans fil de façon à minimiser les contacts humains lors du fonctionnement normal.

Ce périphérique a également été évalué et démontré conforme aux limites d'exposition aux RF d'ISDE dans des conditions d'exposition à des appareils mobiles (les antennes se situent à moins de 20cm du corps d'une personne).

10/ Appendix

10.1. List of Parts and Accessories

Table 41: List of parts and accessories

Description	Supplier	Ordering information
ALS3-US R4 ¹	Kontron	Standard module Kontron IMEI: Packaging unit (ordering) number: L30960-N3480-A400 Module label number: S30960-S3480-A400-1 ² Customer IMEI module: Packaging unit (ordering) number: L30960-N3485-A400 Module label number: S30960-S3485-A400-1 ²
ALS3-US R4 Evaluation module ¹	Kontron	Ordering number: L30960-N3481-A400
DSB75 Support Box	Kontron	Ordering number: L36880-N8811-A100
DSB75 adapter for mounting the evaluation module	Kontron	Ordering number: L30960-N2301-A100
Votronic handset for approval purposes	Votronic / Kon- tron	Votronic ordering number: HH-SI-30.3/V1.1/0 Votronic Entwicklungs- und Produktionsgesellschaft für elektronische Geräte mbH Saarbrücker Str. 8 66386 St. Ingbert Germany Phone: +49-(0)6 89 4 / 92 55-0 Fax: +49-(0)6 89 4 / 92 55-88 Email: contact@votronic.com
SIM card holder incl. push but- ton ejector and slide-in tray	Molex	Ordering numbers: 91228 91236 Sales contacts are listed in Table 42 .
U.FL antenna connector	Hirose or Molex	Sales contacts are listed in Table 42 and Table 43 .

¹ Note: At the discretion of Kontron, modules can be made either in Germany or in China.

² Note: At the discretion of Kontron, module label information can either be laser engraved on the module's shielding or be printed on a label adhered to the module's shielding.

Table 42: Molex sales contacts (subject to change)

Molex For further information please click: http://www.molex.com	Molex Deutschland GmbH Otto-Hahn-Str. 1b 69190 Walldorf Germany Phone: +49-6227-3091-0 Fax: +49-6227-3091-8100 Email: mxgermany@molex.com	American Headquarters Lisle, Illinois 60532 U.S.A. Phone: +1-800-78MOLEX Fax: +1-630-969-1352
Molex China Distributors Beijing, Room 1311, Tower B, COFCO Plaza No. 8, Jian Guo Men Nei Street, 100005 Beijing P.R. China Phone: +86-10-6526-9628 Fax: +86-10-6526-9730	Molex Singapore Pte. Ltd. 110, International Road Jurong Town, Singapore 629174 Phone: +65-6-268-6868 Fax: +65-6-265-6044	Molex Japan Co. Ltd. 1-5-4 Fukami-Higashi, Yamato-City, Kanagawa, 242-8585 Japan Phone: +81-46-265-2325 Fax: +81-46-265-2365

Table 43: Hirose sales contacts (subject to change)

Hirose Ltd. For further information please click: http://www.hirose.com	Hirose Electric (U.S.A.) Inc 2688 Westhills Court Simi Valley, CA 93065 U.S.A. Phone: +1-805-522-7958 Fax: +1-805-522-3217	Hirose Electric Europe B.V. German Branch: Herzog-Carl-Strasse 4 73760 Ostfildern Germany Phone: +49-711-456002-1 Fax: +49-711-456002-299 Email: info@hirose.de
Hirose Electric Europe B.V. UK Branch: First Floor, St. Andrews House, Caldecotte Lake Business Park, Milton Keynes MK7 8LE Great Britain Phone: +44-1908-369060 Fax: +44-1908-369078	Hirose Electric Co., Ltd. 5-23, Osaki 5 Chome, Shinagawa-Ku Tokyo 141 Japan Phone: +81-03-3491-9741 Fax: +81-03-3493-2933	Hirose Electric Europe B.V. Hogehill- weg 8 1101 CC Amsterdam Z-O Netherlands Phone: +31-20-6557-460 Fax: +31-20-6557-469

10.2. Mounting Advice Sheet

To prevent mechanical damage, be careful not to force, bend or twist the module. Be sure it is soldered flat against the host device (see also [Section 7.2.](#)). The advice sheet on the next page shows a number of examples for the kind of bending that may lead to mechanical damage of the module (the module as part of an external application is integrated into a housing).

Mounting Advice

Do **NOT BEND** the Module

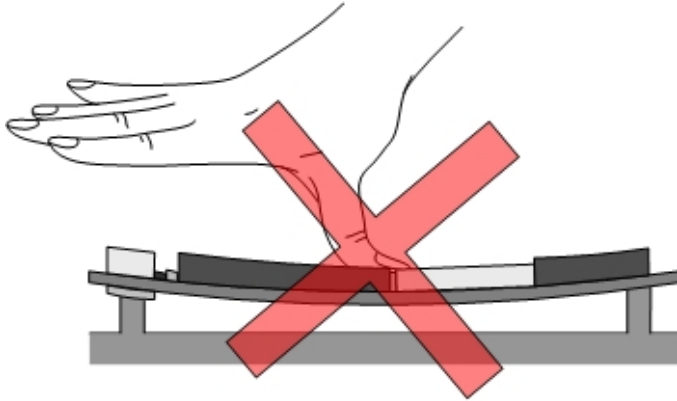

- By pressing from above

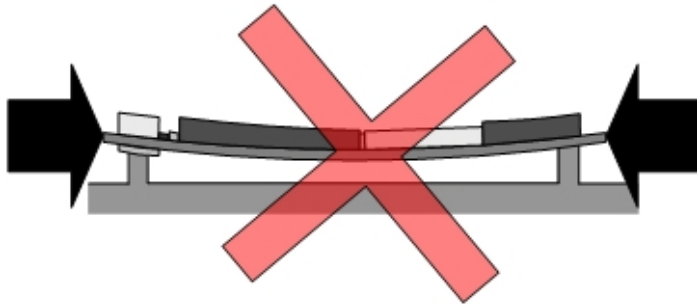

- By mounting under pressure

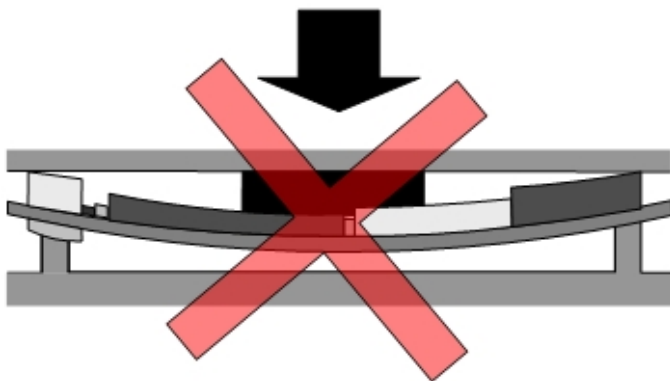

- By putting objects on top

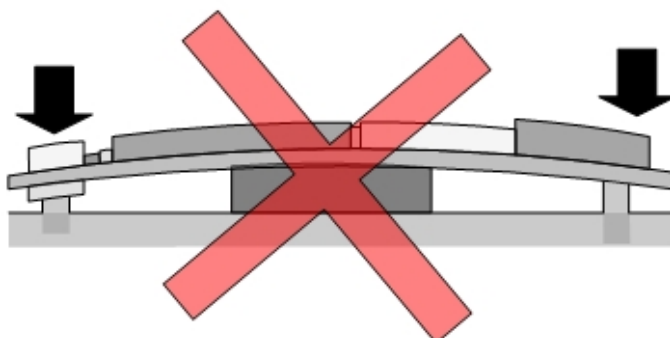

- By putting objects below



About Kontron

Kontron is a global leader in IoT/Embedded Computing Technology (ECT) and offers individual solutions in the areas of Internet of Things (IoT) and Industry 4.0 through a combined portfolio of hardware, software and services. With its standard and customized products based on highly reliable state-of-the-art technologies, Kontron provides secure and innovative applications for a wide variety of industries. As a result, customers benefit from accelerated time-to-market, lower total cost of ownership, extended product lifecycles and the best fully integrated applications.

For more information, please visit: www.kontron.com

Global Headquarters

Kontron Europe GmbH

Gutenbergstraße 2
D-85737 Ismaning, Germany
Phone: +49 8214 4086-0
Mail: info@kontron.com

www.kontron.de



kontron