

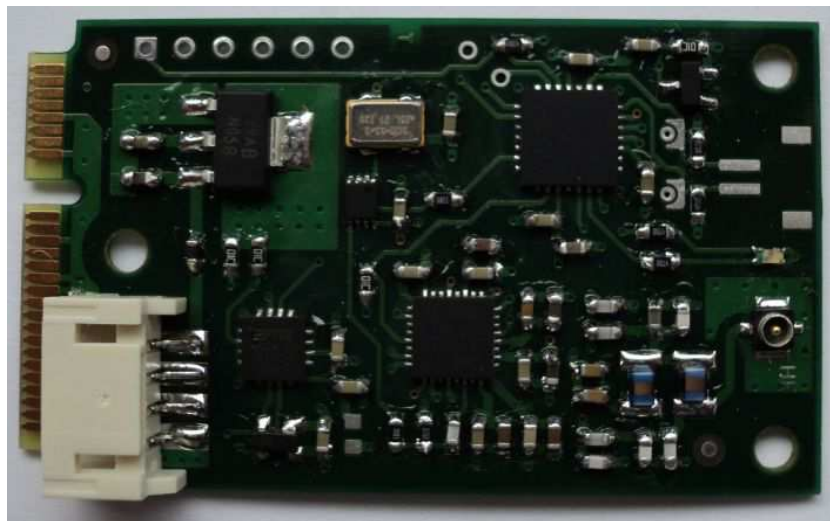

HF-mPCIe RFID Reader Documentation



Contents

1	General description.....	3
1.1	Supported RFID chips.....	3
1.2	Functional description.....	3
1.3	Model, Manufacturer	4
1.4	Labelling	4
2	Applied standards and regulations.....	5
3	Specification.....	6
3.1	Power supply	6
3.2	RFID data	6
3.3	Environmental conditions	7
3.4	Dimensions.....	8
3.4.1	HF-mPCIe RFID Reader	8
3.4.2	Antenna_KEU.....	9
3.5	Dimensions of transponder.....	10
3.6	Connector	11
3.6.1	HF-mPCIe RFID reader	11
3.6.2	Antenna KEU.....	11
3.7	Serial interface parameters	12
3.8	Host communication protocol	12
3.9	Life time	12
3.10	Design-FMEA	12
3.11	Production-FMEA	12
4	Packaging.....	13
4.1	Reader packaging.....	13
4.2	User manual.....	13
5	Embargoed countries	13
6	Installation notes.....	13
7	Product warranty	14
8	Document revisions	15

1 General description

The HF-mPCIe RFID reader is a customer specific adopted RFID reader based on Pondi reader technology. It is designed for the use in an industrial-panel-pc-system.

1.1 Supported RFID chips

Standard ISO 15693 Transponders are supported by the HF-mPCIe RFID reader.

1.2 Functional description

At the detection process the RFID reader reads/writes the data of the transponder. The data is send via an USB comport emulation to host system.

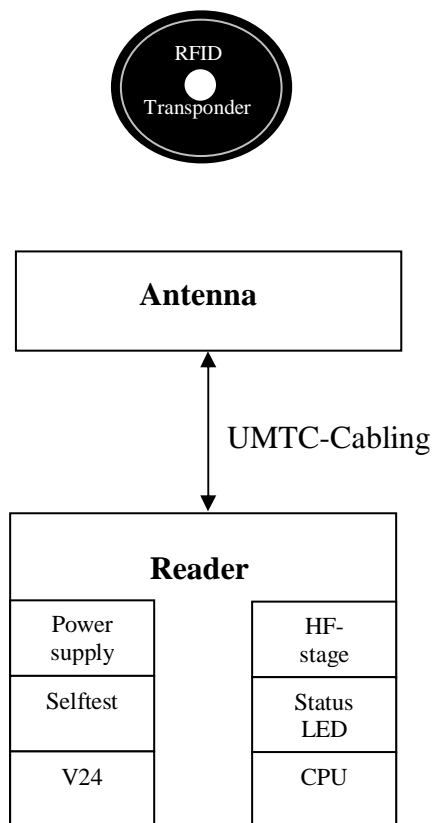

Drawing 1: Block diagram of HF-mPCIe RFID reader

1.3 Model, Manufacturer

The HF-mPCIe RFID reader can be ordered at maxsol at the following order code:
“HF-mPCIe RFID reader”.

The RFID antenna can be ordered at maxsol at the following order code:
“RFID Antenna_KEU”.

Only this antenna may be used for the reader module.
All other antennas are not allowed.

The reader electronic unit consists of a RFID reader main board, with external antenna.
The electronic unit is not assembled into a housing.
The whole production of the HF-mPCIe RFID reader and the Antenna_KEU unit will be done
under the responsibility of maxsol and a certified EMS partner.

1.4 Labelling

On module:

HF RFID module Kontron Europe GmbH Model: HF-mPCIe FCC ID: 2AATH-HFMPCIE IC: 9927C-HFMPCIE
--

Sticker is placed on shield of device

On rear side of device in which this module is mounted

Device contains HF RFID module Model: HF-mPCIe FCC ID: 2AATH-HFMPCIE IC: 9927C-HFMPCIE

2 Applied standards and regulations

The HF-mPCIe RFID reader is conformal to the following radio regulations and standards:

STATEMENTS

FCC Part 15.19
RSS-GEN 7.1.2

This device complies with Part 15 of the FCC Rules and with Industry Canada license-exempt RSS standard(s). Operation is subject to the following two conditions: (1) this device may not cause harmful interference, and (2) this device must accept any interference received, including interference that may cause undesired operation

Le présent appareil est conforme aux CNR d'Industrie Canada applicables aux appareils radio exempts de licence. L'exploitation est autorisée aux deux conditions suivantes : (1) l'appareil ne doit pas produire de brouillage, et (2) l'utilisateur de l'appareil doit accepter tout brouillage radioélectrique subi, même si le brouillage est susceptible d'en compromettre le fonctionnement.

FCC Part 15.21

Changes or modifications not expressly approved by the party responsible for compliance could void the user's authority to operate the equipment.

3 Specification

3.1 Power supply

The circuitry is operates with an internally stabilized voltage for optimum and stable operation.

Value Symbol Unit

Value	Symbol		Unit
Supply voltage (at external USB connector)	V	5 +/-10%	V _{DC}
Max. ripple on supply voltage	V _{SS}	150	mV _{pp}
Current consumption, standby	I _{standby}	<100	mA
Max. current consumption	I _{max}	<200	mA

3.2 RFID data

Value Symbol Unit

Value	Symbol		Unit
RFID Frequency (typical)	f	13,56	MHz
RFID Output power @ 50 Ohm termination	P _{HF}	<100	mW
Read distance	d _{Peak}	0 - 20	mm

The transponder is readable over the whole operation distance between reader antenna and the specified maximum read distance

3.3 Environmental conditions

Value Symbol Unit

Value	Symbol		Unit
Operation temperature range	T _{Operation}	-10 - +85	°C
Storage temperature range	T _{Storage}	-20 - +85	°C
Requested Relative humidity for storage and operation (not condensing)		5 - 95	%

3.4 Dimensions

3.4.1 HF-mPCIe RFID Reader

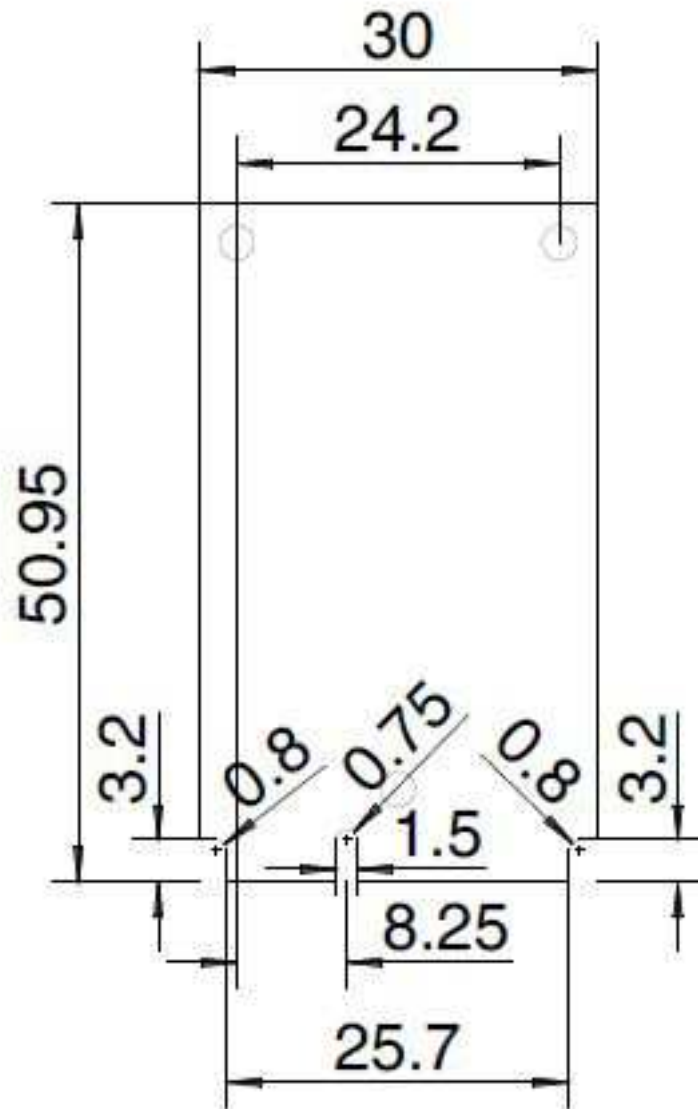

3.4.2 Antenna_KEU

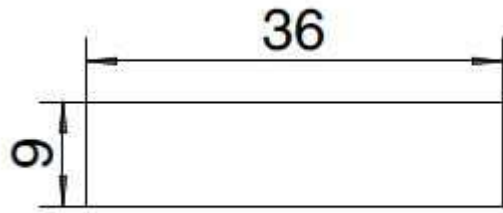

3.5 Dimensions of transponder

Form and dimension t.b.d. by customer.

This has impact on the reading distance.

3.6 Connector

Power/Communication:

3.6.1 HF-mPCIe RFID reader

J2 Pin assignment:	1	+ 5V
	2	D-
	3	D+
	4	GND

Connector type: WR-WTB SMT Male Horizontal Shrouded Header 2.00mm
WE 620104131822, 4 pol.

J5 HF-connector

Connector type: Microwave Coaxial Connectors



3.6.2 Antenna KEU

J1 HF-connector

Connector type: Microwave Coaxial Connectors



3.7 Serial interface parameters

The data between the HF-mPCIe RFID reader and a host system are transmitted via a USB comport emulation.

Interface parameters:

Baud rate 19.200

No of Bits 8

Stop bit 1; Parity N

Handshake No hardware or software handshake

3.8 Host communication protocol

The communication protocol between a host system and the HF-mPCIe RFID reader is defined in the document "P2 Interface Protocol"

3.9 Life time

No MTBF calculation.

3.10 Design-FMEA

No

3.11 Production-FMEA

No

4 Packaging

4.1 Reader packaging

Every reader is packed into an ESD proof bag.

Every antenna is packed into an ESD proof bag.

4.2 User manual

One documentation is delivered to customer in paper and pdf.

5 Embargoed countries

In customer responsibility.

6 Installation notes

Special ESD prevention is required to assemble the HF-mPCIe RFID reader.

It is recommend to use a ESD wristband when you unpack the reader and connect it to the host system.

The system power has to be switched off prior to the assembly.

Be aware of the following possible environmental effects when your are installing the HFmPCIe RFID reader into a device.

Also the transponders might be effected by:

- Nearby existing metal objects like housings, shielding and also PCB-boards with large ground plates.
- EMC effects from cables
- EMC effects from magnetic fields.

Metal surface in direct vicinity of the active antenna will detune the antenna and thus have a direct influence to the operating distance. Increase the distance between the antenna and the metal layer to the possible maximum for least influence.

Communication between the reader and a transponder can never pass through a metal layer.

7 Product warranty

maxsol provides customer assistance in various technical areas, but does not have full access to data concerning the use and applications of customer's products. Therefore, maxsol assumes no liability and is not responsible for customer applications or product or software design or performance relating to systems or applications incorporating maxsol products.

maxsol assumes no liability and is not responsible for infringement of patents and/or any other intellectual or industrial property rights of third parties, which may result from assistance provided by maxsol. maxsol is not liable for infringements of patents and/or any other intellectual or industrial property rights of third parties resulting out of the usage in the customers industrial system.

maxsol products are not designed, intended, authorized or warranted to be suitable for life support applications or any other life critical applications which could involve potential risk of death, personal injury or severe property or environmental damage. A critical component is a component used in a life-supporting device or system whose failure can reasonably be expected to cause the failure of that life-support device or system, or to affect its safety or effectiveness of that device or system. Life support devices or systems are intended (a) to be implanted in the human body, or (b) to support and/or maintain and sustain human life. If they fail, it is reasonable to assume that the health of the user may be endangered.

The product warranty is defined by governmental law and in maxsol's "General Conditions for the supply of products and services".

8 Document revisions

Datum	Version	Status
27.06.2013	1.0	draft
06.02.2014	1.1	Added FCC Statements
10.02.2013	1.2	Added some changes
07.04.2014	1.3	Added 1.4 Labelling