

WAP-3518 Dual Band Wireless Router

Quick Start Guide

Panel

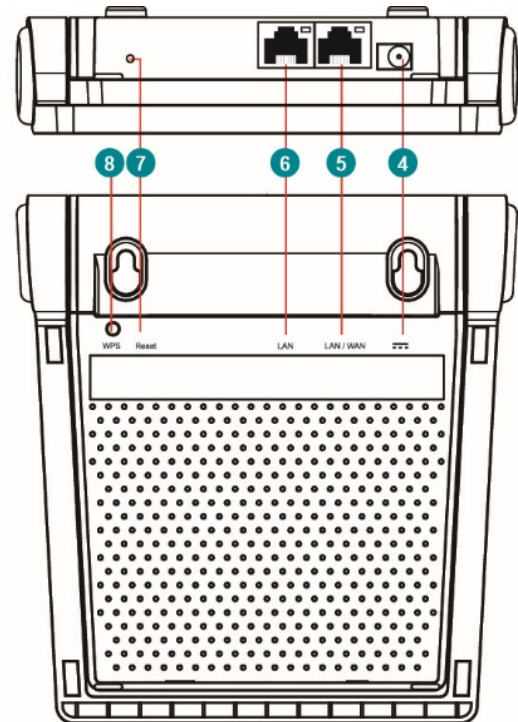
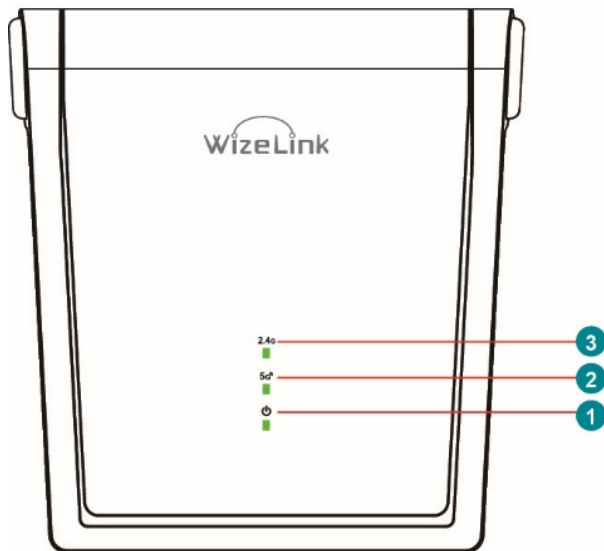

1 Power LED :

Off : No power

On(Green Light) : Device is ready

Flashing(Orange Light) : WPS is processing or enter the reset mode.

2 5G Signal LED :

No light : No 5GHz signal.

Green Light : 5GHz Wireless system is ready.

Flashing Green Light : Transmitting or receiving data via wireless connection.

3 2.4G Signal LED :

No Light : No 2.4GHz signal.

Green Light : 2.4GHz Wireless system is ready.

Flashing Green Light : Transmitting or receiving data via wireless connection.

4 Power (DC IN) Port :

Connect your router to an AC socket with the power adapter.

5 WAN Port :

Connect a network cable into this port to establish WAN connection. When in MESH mode, WAN port works as a LAN Port.

6 LAN Port:

Connect a network cable into these ports to establish LAN connection.

7 Reset Button:

Press and hold the button for 10 seconds. When the power indicator is flashing orange light, the router will enter the reset mode, and revert back to Factory settings.

8 WPS Button:

Pushing this button will initiate automatic pairing.

Safety Information

- Do not let liquids make contact with the router. If this happens, wipe the router with a dry cloth immediately.
- Do not use thinner, alcohol, benzene or other chemicals when cleaning the box.
- To avoid electrical shock, do not disassemble the case.
- To prevent overheating and damage to the router, avoid placing router in areas with dust and sand.
- To avoid areas with strong magnetic fields, do not place the router near metallic objects or similar environments.
- Do not place the router under direct sunlight or expose router to extreme temperatures.
- Do not drop, hit, or place heavy objects on the router.

1. Installation

Wired Connection

- a. Plug in power adapter.
- b. Use a network cable to connect modem and router's WAN port.
- c. Use a network cable to connect your computer and router's LAN port.

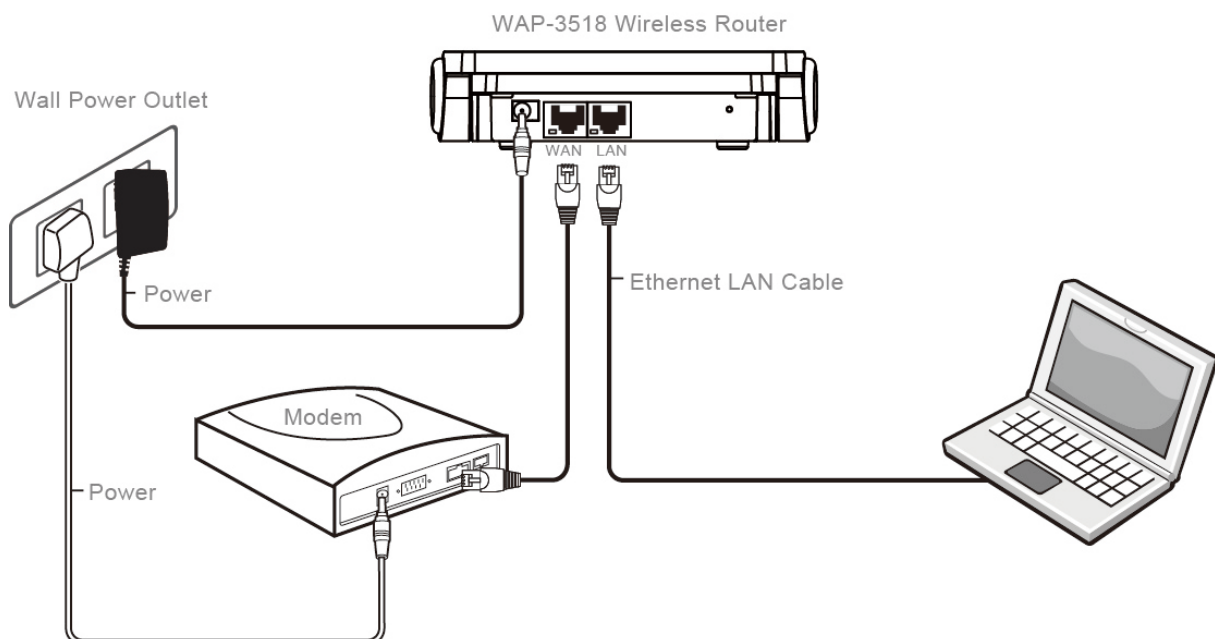

Wireless Connection

Method 1: Manually connect to the network

- a. Plug in power adapter.
- b. Use a network cable to connect modem and router's WAN port.
- c. Connect your computer or mobile phone to router via WiFi:
 - ▶ SSID : [TTI_3518_5G](#) or [TTI_3518_2.4G](#)
 - ▶ Password : [00000000](#) (default value)

Method 2: Use WPS to connect to the network

(Do not use WPS if the wireless network has not been encrypted)

- a. Press down on the WPS button on router until the power light flashes orange indicating that the WPS pairing is in progress.
- b. When router power light flashes orange, start the WPS pairing on your wireless device within 2 minutes, or follow the instructions on the wireless device to set WPS.
- c. Your wireless device will start scanning and will connect to the router's wireless network. When the power light on router stops flashing, the device and router has successfully connected.

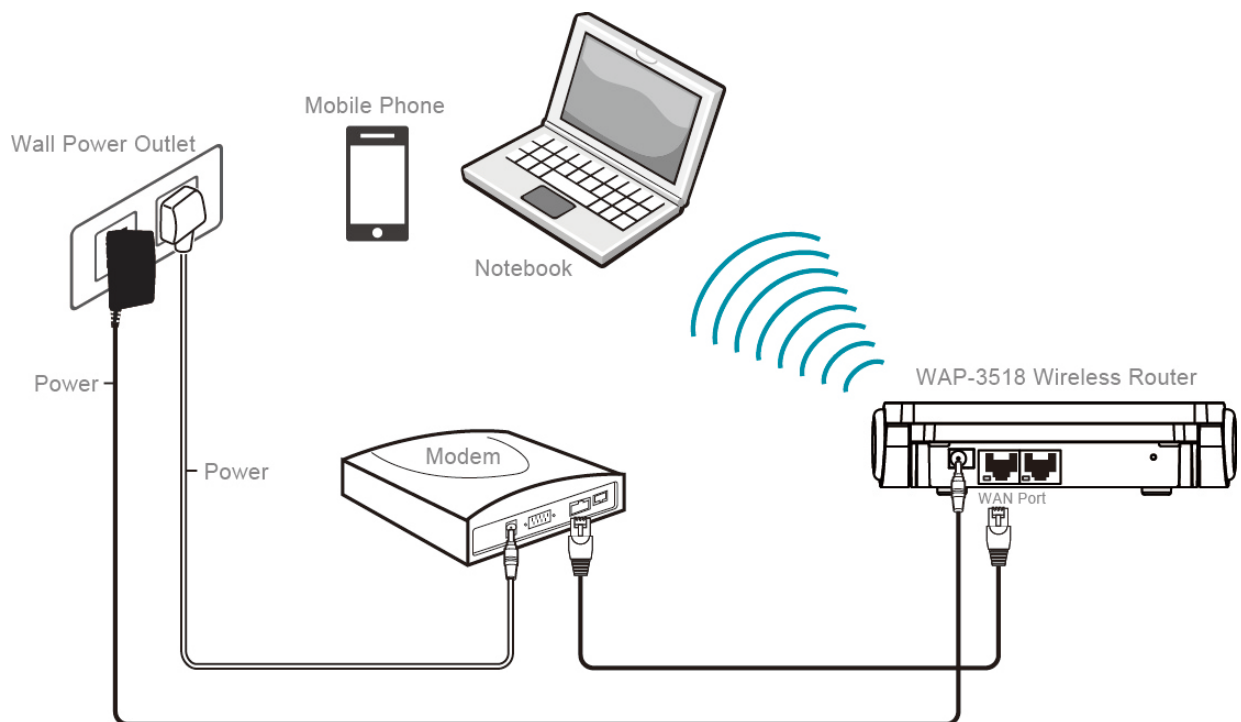

2. Router Set-Up via Mobile Phone App



- Connect your mobile phone to router via WiFi.
SSID : [TTI_3518_5G](#) or [TTI_3518_2.4G](#)
Password : [00000000](#) (default value)
- Open the Mobile Phone App, key in the default user name ([admin](#)) and password ([admin](#)).

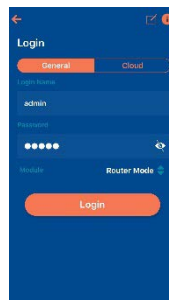

- After login, you can now set-up router.



3. Router Set-Up via Web UI

Your Wireless Router comes with an intuitive web graphical user interface (GUI) that allows you to easily configure its various features through a web browser such as Internet Explorer, Firefox, Safari, or Google Chrome.

Login to Web UI(Wired Connection or Wireless Connection by computer)

- a. Manually key in the wireless router's default IP address ([192.168.10.1](#)) on your web browser.
- b. On the login page, key in the default user name ([admin](#)) and password ([admin](#)).
- c. You can now use the Web GUI to configure various settings of your Wireless Router.

4. Easy Mesh Set Up

Controller Device Set up

- a) Use network cable and connect your modem or router LAN port to the LAN port on the first WAP-3518 and plug in the power supply.
- b) Connect to the WAP-3518 device with a smart device (notebook or mobile phone)
 - Wired connection -- Connect to the LAN port of the WAP-3518 device via the RJ-45 cable.
 - Wireless connection -- a wireless network connected to the WAP-3518 device
SSID : [TTI_3518_5G](#) or [TTI_3518_2.4G](#)
Password : [00000000](#) (default value)
- c) Launch a web browser, type in the IP address ([192.168.10.1](#)) in the browser's address bar of the WAP-3518 device.
- d) On the login page, type in the default user name ([admin](#)) and password ([admin](#)).
- e) Follow the setup steps below to set up the Controller Device.
 1. Click the **EASYMESH** tab on the left menu.
 2. Then select the Role as a **Controller** (**wlan0** is the default value for the Backhaul BSS).
 3. Click **Save & Apply** to finish the Controller Device set up.

WizeLink WAP-3518 Enrutador De Malla

English Português Español

Salir Reiniciar

ESTABLECER INALÁMBRICA NETWORKING CORTAFUEGOS ADMINISTRACIÓN

EasyMesh General Settings

This page is used to configure the parameters for EasyMesh feature of your Access Point.

STATUS

1 AJUSTES

EASYMESH

Device Name: 01D050S3516

2 Role: Controller Agent Disabled

Backhaul BSS: **3** wlan0 wlan1

Save Save & Apply

Agent Device Set up

- a) Plug the power adapter in to the second WAP-3518.
- b) Connect to the second WAP-3518 device with a smart device (notebook or mobile phone)
 - Wired connection -- Connect to the LAN port of the WAP-3518 device via the RJ-45 cable.
 - Wireless connection -- a wireless network connected to the WAP-3518 device
SSID : [TTI_3518_5G](#) or [TTI_3518_2.4G](#)

Password : 00000000 (default value)

- c) Launch a web browser, type in the IP address (192.168.10.1) in the browser's address bar of the WAP-3518 device.
- d) On the login page, type in the default user name (admin) and password (admin).
- e) Follow the setup steps below to set up the Controller Device.
 4. Click the **EASYMESH** tab on the left menu.
 5. Then select the Role as an **Agent** (wlan0 is the default value for the Backhaul BSS).
 6. Click **Save & Apply** to finish the Agent Device set up.

The screenshot shows the WizeLink WAP-3518 web interface. At the top, there are language options (English, Português, Español) and buttons for 'Salir' and 'Reiniciar'. The main navigation bar includes 'ESTABLECER', 'INALÁMBRICA', 'NETWORKING', 'CORTAFUEGOS', and 'ADMINISTRACIÓN'. The 'EASYMESH' tab is highlighted in the left sidebar (marked with a red box and '1'). The main content area is titled 'EasyMesh General Settings' and contains the following fields:

- Device Name:** 01D03953516 (marked with a red box and '2')
- Role:** Controller, Agent (selected), Disabled
- Backhaul STA:** wlan0 (selected), wlan1

At the bottom, there are 'Save' and 'Save & Apply' buttons. The 'Save & Apply' button is highlighted with a red box and '3'.

Easy Mesh Connection Set up

- a) Press and hold the WPS bottom of the first (Controller) and the second WAP-3518 (Agent) for more than two seconds, until the power light of both flashes orange indicating that the WPS pairing is in progress.
- b) Wait until the power light turn to green solid light, which indicates the WAP-3518 Controller and Agent has been successfully connected wirelessly.
- c) If necessary, you can set the third WAP-3518 (Agent), refer to the: Agent Device Set up & Easy Mesh Connection Set up.

5. Mounting Instruction

Elegant design to have multiple usage scenarios: to be mounted on the wall as well as to be placed vertically or horizontally on the table.

Vertically or Horizontally on the table



Mounted on the wall

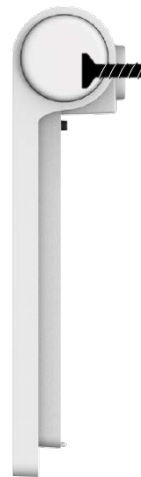

Screw Length/Diameter:

Depending on the type of wall mounting, make sure to use screws of appropriate length and diameter (note: screws are not included in the package)

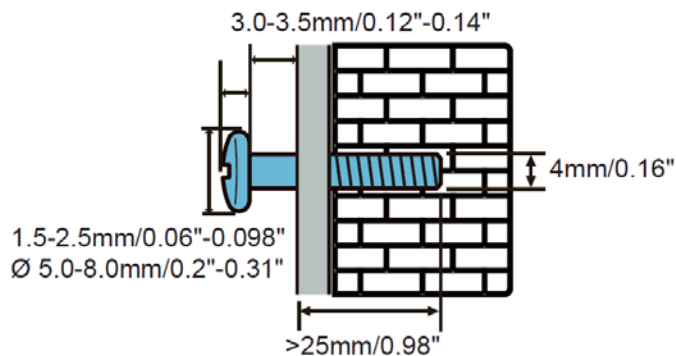

Schematic diagram of the way of wall hanging:

1. Drill two holes in the wall.
2. Fix the pins and screws in the holes.
3. Hang the router on the fastened screws.

Federal Communications Commission Statement

This device complies with Part 15 of the FCC Rules. Operation is subject to the following two conditions: (1) This device may not cause harmful interference, and (2) This device must accept any interference received, including interference that may cause undesired operation.

This equipment has been tested and found to comply with the limits for a Class B digital device, pursuant to Part 15 of the FCC Rules. These limits are designed to provide reasonable protection against harmful interference in a residential installation. This equipment generates, uses and can radiate radio frequency energy and, if not installed and used in accordance with the instructions, may cause harmful interference to radio communications. However, there is no guarantee that interference will not occur in a particular installation. If this equipment does cause harmful interference to radio or television reception, which can be determined by turning the equipment off and on, the user is encouraged to try to correct the interference by one of the following measures:

- Reorient or relocate the receiving antenna.
- Increase the separation between the equipment and receiver.
- Connect the equipment into an outlet on a circuit different from that to which the receiver is connected.
- Consult the dealer or an experienced radio/TV technician for help.

FCC Caution: Any changes or modifications not expressly approved by the party responsible for compliance could void the user's authority to operate this equipment.

This transmitter must not be co-located or operating in conjunction with any other antenna or transmitter.

Radiation Exposure Statement:

This equipment complies with FCC radiation exposure limits set forth for an uncontrolled environment. This equipment should be installed and operated with minimum distance 20cm between the radiator & your body.