



FCC TEST REPORT (15.407)

REPORT NO.: RF130715C30-2
MODEL NO.: STB-2560
FCC ID: 2AATB-000000
RECEIVED: Jul. 15, 2013
TESTED: Jul. 22, 2013 ~ Aug. 08, 2013
ISSUED: Aug. 14, 2013

APPLICANT: TATUNG TECHNOLOGY INC

ADDRESS: 22, CHUNGSHAN N.RD., 3RD SEC., TAIPEI, TAIWAN, 10435

ISSUED BY: Bureau Veritas Consumer Products Services
(H.K.) Ltd., Taoyuan Branch

LAB ADDRESS: No. 47, 14th Ling, Chia Pau Vil., Lin Kou Dist.,
New Taipei City, Taiwan (R.O.C)

TEST LOCATION: No. 19, Hwa Ya 2nd Rd, Wen Hwa Tsuen, Kwei
Shan Hsiang, Taoyuan Hsien 333, Taiwan, R.O.C.

This report should not be used by the client to claim product certification, approval, or endorsement by TAF or any government agencies.



This report is for your exclusive use. Any copying or replication of this report to or for any other person or entity, or use of our name or trademark, is permitted only with our prior written permission. This report sets forth our findings solely with respect to the test samples identified herein. The results set forth in this report are not indicative or representative of the quality or characteristics of the lot from which a test sample was taken or any similar or identical product unless specifically and expressly noted. Our report includes all of the tests requested by you and the results thereof based upon the information that you provided to us. You have 60 days from date of issuance of this report to notify us of any material error or omission caused by our negligence, provided, however, that such notice shall be in writing and shall specifically address the issue you wish to raise. A failure to raise such issue within the prescribed time shall constitute your unqualified acceptance of the completeness of this report, the tests conducted and the correctness of the report contents. Unless specific mention, the uncertainty of measurement has been explicitly taken into account to declare the compliance or non-compliance to the specification

TABLE OF CONTENTS

RELEASE CONTROL RECORD	4
1. CERTIFICATION	5
2. SUMMARY OF TEST RESULTS	6
2.1 MEASUREMENT uncertainty	6
3. GENERAL INFORMATION	7
3.1 GENERAL DESCRIPTION OF EUT	7
3.2 DESCRIPTION OF TEST MODES	8
3.2.1 Test Mode Applicability and tested channel detail	9
3.3 DESCRIPTION OF SUPPORT UNITS	11
3.3.1 CONFIGURATION OF SYSTEM UNDER TEST	11
3.4 Duty cycle of test signal	12
3.5 GENERAL DESCRIPTION OF APPLIED STANDARDS	12
4. TEST TYPES AND RESULTS	13
4.1 Radiated Emission AND BANDEDGE Measurement	13
4.1.1 LIMITS OF RADIATED EMISSION AND BANDEDGE MEASUREMENT	13
4.1.2 LIMITS OF UNWANTED EMISSION OUT OF THE RESTRICTED BANDS	14
4.1.3 TEST INSTRUMENTS	15
4.1.4 TEST PROCEDURES	16
4.1.5 DEVIATION FROM TEST STANDARD	16
4.1.6 TEST SETUP	17
4.1.7 EUT OPERATING CONDITION	17
4.1.8 Test RESULTS	18
4.2 CONDUCTED EMISSION MEASUREMENT	25
4.2.1 LIMITS OF CONDUCTED EMISSION MEASUREMENT	25
4.2.2 TEST INSTRUMENTS	25
4.2.3 TEST PROCEDURES	26
4.2.4 DEVIATION FROM TEST STANDARD	26
4.2.5 TEST SETUP	26
4.2.6 EUT OPERATING CONDITIONS	26
4.2.7 TEST RESULTS	27
4.3 Peak transmit power MEASUREMENT	29
4.3.1 LIMITS OF PEAK TRANSMIT POWER MEASUREMENT	29
4.3.2 TEST SETUP	29
4.3.3 TEST INSTRUMENTS	30
4.3.4 TEST PROCEDURE	30
4.3.5 DEVIATION FROM TEST STANDARD	30
4.3.6 EUT OPERATING CONDITIONS	30
4.3.7 TEST RESULTS	31
4.4 PEAK power spectral density measurement	32
4.4.1 LIMITS OF PEAK POWER SPECTRAL DENSITY MEASUREMENT	32
4.4.2 TEST SETUP	32



A D T

4.4.3	TEST INSTRUMENTS	32
4.4.4	TEST PROCEDURES	32
4.4.5	DEVIATION FROM TEST STANDARD	33
4.4.6	EUT OPERATING CONDITIONS	33
4.4.7	TEST RESULTS	33
4.5	Peak power EXCURSION MEASUREMENT	35
4.5.1	LIMITS OF PEAK POWER EXCURSION MEASUREMENT	35
4.5.2	TEST SETUP	35
4.5.3	TEST INSTRUMENTS	35
4.5.4	TEST PROCEDURE	35
4.5.5	DEVIATION FROM TEST STANDARD	35
4.5.6	EUT OPERATING CONDITIONS	35
4.5.7	TEST RESULTS	36
4.6	FREQUENCY STABILITY	37
4.6.1	LIMITS OF FREQUENCY STABILITY MEASUREMENT	37
4.6.2	TEST SETUP	37
4.6.3	TEST INSTRUMENTS	37
4.6.4	TEST PROCEDURE	38
4.6.5	DEVIATION FROM TEST STANDARD	38
4.6.6	EUT OPERATING CONDITION	38
4.6.7	TEST RESULTS	39
5.	PHOTOGRAPHS OF THE TEST CONFIGURATION	40
6.	INFORMATION ON THE TESTING LABORATORIES	41
7.	APPENDIX A - Modifications recorders for engineering changes to the eut BY THE LAB	42



A D T

RELEASE CONTROL RECORD

ISSUE NO.	REASON FOR CHANGE	DATE ISSUED
RF130715C30-2	Original release	Aug. 14, 2013

1. CERTIFICATION

PRODUCT: Set-top Box
MODEL NO.: STB-2560
BRAND: TATUNG TECHNOLOGY INC
APPLICANT: TATUNG TECHNOLOGY INC
TESTED: Jul. 22, 2013 ~ Aug. 08, 2013
TEST SAMPLE: Production Unit
STANDARDS: **FCC Part 15, Subpart E (Section 15.407)**
ANSI C63.10-2009

The above equipment (model: STB-2560) has been tested by **Bureau Veritas Consumer Products Services (H.K.) Ltd., Taoyuan Branch**, and found compliance with the requirement of the above standards. The test record, data evaluation & Equipment Under Test (EUT) configurations represented herein are true and accurate accounts of the measurements of the sample's EMC characteristics under the conditions specified in this report.

PREPARED BY : Vera Huang , **DATE** : Aug. 14, 2013

Vera Huang / Specialist

APPROVED BY : Sam chen , **DATE** : Aug. 14, 2013

Sam Chen / Assistant Manager

2. SUMMARY OF TEST RESULTS

The EUT has been tested according to the following specifications:

APPLIED STANDARD: FCC PART 15, SUBPART E (SECTION 15.407)			
STANDARD SECTION	TEST TYPE	RESULT	REMARK
15.407(b)(6)	AC Power Conducted Emission	PASS	Meet the requirement of limit. Minimum passing margin is -17.90dB at 0.38438MHz.
15.407(b/1/2/3) (b)(6)	Spurious Emissions	PASS	Meet the requirement of limit. Minimum passing margin is -0.47dB at 5350MHz.
15.407(a/1/2)	Peak Transmit Power	PASS	Meet the requirement of limit.
15.407(a)(6)	Peak Power Excursion	PASS	Meet the requirement of limit.
15.407(a/1/2)	Peak Power Spectral Density	PASS	Meet the requirement of limit.
15.407(g)	Frequency Stability	PASS	Meet the requirement of limit.
15.203	Antenna Requirement	PASS	No antenna connector is used.

2.1 MEASUREMENT UNCERTAINTY

Where relevant, the following measurement uncertainty levels have been estimated for tests performed on the EUT as specified in CISPR 16-4-2:

MEASUREMENT	FREQUENCY	UNCERTAINTY
Conducted emissions	9kHz~30MHz	2.44 dB
Radiated emissions	30MHz ~ 200MHz	2.93 dB
	200MHz ~1000MHz	2.95 dB
	1GHz ~ 18GHz	2.26 dB
	18GHz ~ 40GHz	1.94 dB

This uncertainty represents an expanded uncertainty expressed at approximately the 95% confidence level using a coverage factor of $k = 2$.



3. GENERAL INFORMATION

3.1 GENERAL DESCRIPTION OF EUT

EUT	Set-top Box
MODEL NO.	STB-2560
POWER SUPPLY	12Vdc (adapter)
MODULATION TYPE	64QAM, 16QAM, QPSK, BPSK
MODULATION TECHNOLOGY	OFDM
TRANSFER RATE	802.11n: up to MCS7
OPERATING FREQUENCY	5270 ~ 5310MHz, 5510 ~ 5670MHz
NUMBER OF CHANNEL	5270 ~ 5310MHz: 2 for 802.11n (40MHz) 5510 ~ 5670MHz: 3 for 802.11n (40MHz)
OUTPUT POWER	213.796mW
ANTENNA TYPE	PCB antenna with 1.65dBi gain (5270 ~ 5310MHz) PCB antenna with 2.74dBi gain (5510 ~ 5670MHz)
ANTENNA CONNECTOR	NA
DATA CABLE	Refer to Note as below
I/O PORTS	Refer to user's manual
ACCESSORY DEVICES	Refer to Note as below

NOTE:

1. The EUT has following accessories.

ITEM	BRAND	MODEL	DESCRIPTION
AC Adapter 1	APD	WA-18J12FU	I/P: 100-240Vac, 50-60Hz, 0.5A O/P: 12Vdc, 1.5A
AC Adapter 2	APD	WA-18Q12FU	I/P: 100-240Vac, 50-60Hz, 0.5A O/P: 12Vdc, 1.5A

2. The EUT incorporates a MIMO function. Physically, the EUT provides 4 completed transmitters and 4 receivers.

MODULATION MODE	TX FUNCTION
802.11n (40MHz)	4TX

3. The above EUT information is declared by the manufacturer and for more detailed features description, please refer to the manufacturer's specifications or User's Manual.



3.2 DESCRIPTION OF TEST MODES

FOR 5270 ~ 5310MHz

2 channels are provided for 802.11n (40MHz):

CHANNEL	FREQUENCY	CHANNEL	FREQUENCY
54	5270 MHz	62	5310 MHz

FOR 5510 ~ 5670MHz

3 channels are provided for 802.11n (40MHz):

CHANNEL	FREQUENCY	CHANNEL	FREQUENCY
102	5510MHz	134	5670MHz
110	5550MHz		

3.2.1 TEST MODE APPLICABILITY AND TESTED CHANNEL DETAIL

EUT CONFIGURE MODE	APPLICABLE TO				DESCRIPTION
	RE≥1G	RE<1G	PLC	APCM	
-	√	√	√	√	-

Where **RE≥1G**: Radiated Emission above 1GHz **RE<1G**: Radiated Emission below 1GHz
PLC: Power Line Conducted Emission **APCM**: Antenna Port Conducted Measurement

NOTE: The EUT had been pre-tested on the positioned of each 3 axis. The worst case was found when positioned on **Z-plane**.

RADIATED EMISSION TEST (ABOVE 1GHz):

- Pre-Scan has been conducted to determine the worst-case mode from all possible combinations between available modulations, data rates and antenna ports (if EUT with antenna diversity architecture).
- Following channel(s) was (were) selected for the final test as listed below.

MODE	FREQ. BAND (MHz)	AVAILABLE CHANNEL	TESTED CHANNEL	MODULATION TECHNOLOGY	MODULATION TYPE	DATA RATE (Mbps)
802.11n (40MHz)	5270-5310	54 to 62	54, 62	OFDM	BPSK	13.5
802.11n (40MHz)	5510-5670	102 to 134	102, 110, 134	OFDM	BPSK	13.5

RADIATED EMISSION TEST (BELOW 1GHz):

- Pre-Scan has been conducted to determine the worst-case mode from all possible combinations between available modulations, data rates and antenna ports (if EUT with antenna diversity architecture).
- Following channel(s) was (were) selected for the final test as listed below.

MODE	FREQ. BAND (MHz)	AVAILABLE CHANNEL	TESTED CHANNEL	MODULATION TECHNOLOGY	MODULATION TYPE	DATA RATE (Mbps)
802.11n (40MHz)	5270-5310	54 to 62	54	OFDM	BPSK	13.5
802.11n (40MHz)	5510-5670	102 to 134	134	OFDM	BPSK	13.5

POWER LINE CONDUCTED EMISSION TEST:

The EUT was tested with the following mode.

MODE	TEST CONDITION
1	WLAN (5G) Link + Adapter 1
2	WLAN (5G) Link + Adapter 2

NOTE: Test mode 2 was the worst case and only this mode was presented in this report.



BANDEDGE MEASUREMENT:

- Pre-Scan has been conducted to determine the worst-case mode from all possible combinations between available modulations, data rates and antenna ports (if EUT with antenna diversity architecture).
- Following channel(s) was (were) selected for the final test as listed below.

MODE	FREQ. BAND (MHz)	AVAILABLE CHANNEL	TESTED CHANNEL	MODULATION TECHNOLOGY	MODULATION TYPE	DATA RATE (Mbps)
802.11n (40MHz)	5270-5310	54 to 62	54, 62	OFDM	BPSK	13.5
802.11n (40MHz)	5510-5670	102 to 134	102, 110, 134	OFDM	BPSK	13.5

ANTENNA PORT CONDUCTED MEASUREMENT:

- This item includes all test value of each mode, but only includes spectrum plot of worst value of each mode.
- Pre-Scan has been conducted to determine the worst-case mode from all possible combinations between available modulations, data rates and antenna ports (if EUT with antenna diversity architecture).
- Following channel(s) was (were) selected for the final test as listed below.

MODE	FREQ. BAND (MHz)	AVAILABLE CHANNEL	TESTED CHANNEL	MODULATION TECHNOLOGY	MODULATION TYPE	DATA RATE (Mbps)
802.11n (40MHz)	5270-5310	54 to 62	54, 62	OFDM	BPSK	13.5
802.11n (40MHz)	5510-5670	102 to 134	102, 110, 134	OFDM	BPSK	13.5

TEST CONDITION:

APPLICABLE TO	ENVIRONMENTAL CONDITIONS	INPUT POWER	TESTED BY
RE \geq 1G	25deg. C, 65%RH	120Vac, 60Hz	Anson Lin
RE $<$ 1G	25deg. C, 65%RH	120Vac, 60Hz	Anson Lin
PLC	25deg. C, 65%RH	120Vac, 60Hz	Johnson Liao
APCM	25deg. C, 65%RH	120Vac, 60Hz	Howard Kao

3.3 DESCRIPTION OF SUPPORT UNITS

The EUT has been tested as an independent unit together with other necessary accessories or support units. The following support units or accessories were used to form a representative test configuration during the tests.

NO.	PRODUCT	BRAND	MODEL NO.	SERIAL NO.	FCC ID
1	NOTEBOOK	DELL	Inspiron 14R	8LRKKW1	N/A

NO.	SIGNAL CABLE DESCRIPTION OF THE ABOVE SUPPORT UNITS
1	N/A

NOTE:

1. All power cords of the above support units are non shielded (1.8m).
2. Items 1 acted as a communication partner to transfer data.

3.3.1 CONFIGURATION OF SYSTEM UNDER TEST

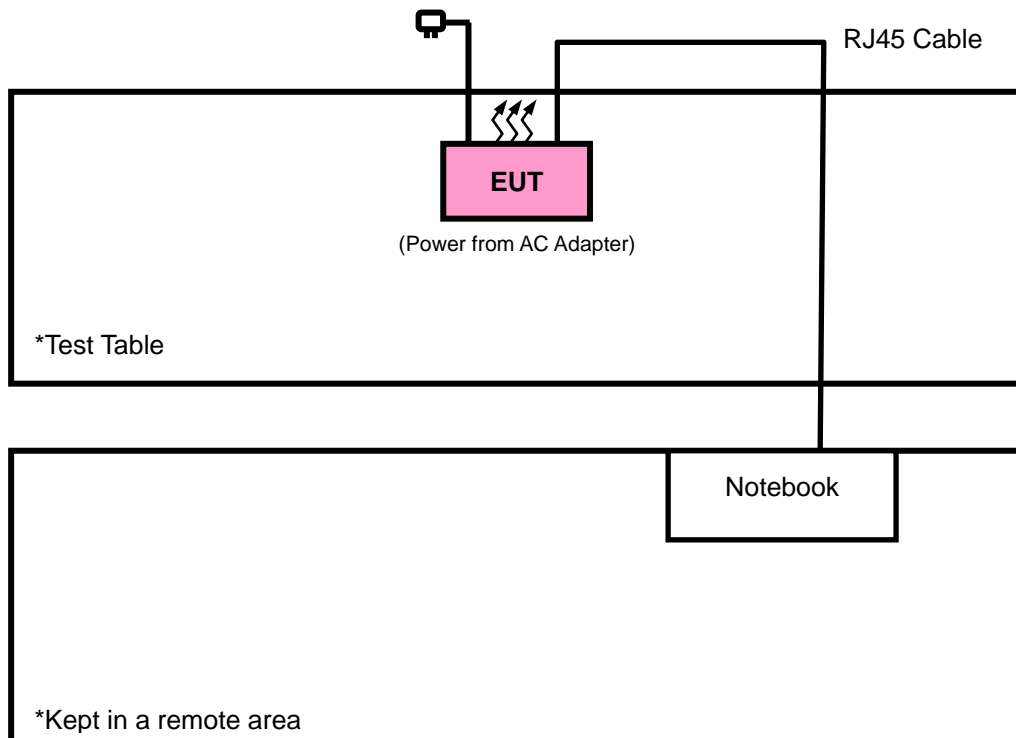

3.4 DUTY CYCLE OF TEST SIGNAL

If duty cycle is < 98%, duty factor shall be considered.

802.11n (40MHz): Duty cycle = $2.379/2.484 = 0.958$, Duty factor = $10 * \log(1/0.958) = 0.19$

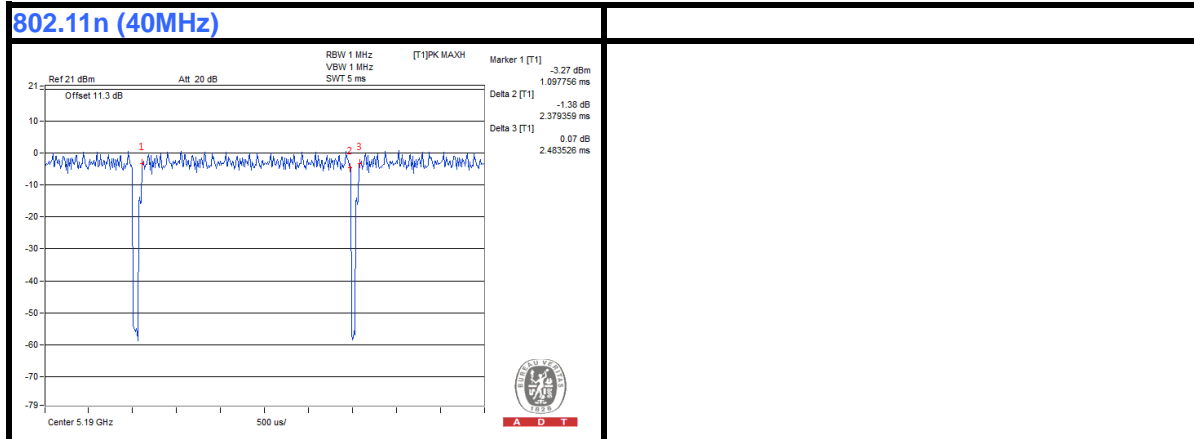

3.5 GENERAL DESCRIPTION OF APPLIED STANDARDS

The EUT is a RF Product. According to the specifications of the manufacturer, it must comply with the requirements of the following standards:

FCC Part 15, Subpart E (15.407)

ANSI C63.10-2009

KDB 789033 D01 General UNII Test Procedures v01r02

662911 D01 Multiple Transmitter Output v01 r02

All test items have been performed and recorded as per the above standards.

NOTE: The EUT is also considered as a kind of computer peripheral, because the connection to computer is necessary for typical use. It has been verified to comply with the requirements of FCC Part 15, Subpart B, Class B. The test report has been issued separately.

4. TEST TYPES AND RESULTS

4.1 RADIATED EMISSION AND BANDEDGE MEASUREMENT

4.1.1 LIMITS OF RADIATED EMISSION AND BANDEDGE MEASUREMENT

Radiated emissions which fall in the restricted bands must comply with the radiated emission limits specified as below table:

FREQUENCIES (MHz)	FIELD STRENGTH (microvolts/meter)	MEASUREMENT DISTANCE (meters)
0.009 ~ 0.490	2400/F(kHz)	300
0.490 ~ 1.705	24000/F(kHz)	30
1.705 ~ 30.0	30	30
30 ~ 88	100	3
88 ~ 216	150	3
216 ~ 960	200	3
Above 960	500	3

NOTE:

1. The lower limit shall apply at the transition frequencies.
2. Emission level (dBuV/m) = 20 log Emission level (uV/m).
3. For frequencies above 1000MHz, the field strength limits are based on average detector, however, the peak field strength of any emission shall not exceed the maximum permitted average limits, specified above by more than 20dB under any condition of modulation.



4.1.2 LIMITS OF UNWANTED EMISSION OUT OF THE RESTRICTED BANDS

APPLICABLE TO	LIMIT	
	FIELD STRENGTH AT 3m (dB μ V/m)	
	PK	AV
	74	54
√	EIRP LIMIT (dBm)	EQUIVALENT FIELD STRENGTH AT 3m (dB μ V/m)
	PK	PK
	-27	68.3

NOTE: The following formula is used to convert the equipment isotropic radiated power (eirp) to field strength:

$$E = \frac{1000000\sqrt{30P}}{3} \mu\text{V/m, where P is the eirp (Watts).}$$



4.1.3 TEST INSTRUMENTS

DESCRIPTION & MANUFACTURER	MODEL NO.	SERIAL NO.	DATE OF CALIBRATION	DUE DATE OF CALIBRATION
Test Receiver ROHDE & SCHWARZ	ESCI	100424	Aug. 21, 2012	Aug. 20, 2013
Spectrum Analyzer ROHDE & SCHWARZ	FSU43	101261	Dec. 17, 2012	Dec. 16, 2013
BILOG Antenna SCHWARZBECK	VULB9168	9168-472	Mar. 25, 2013	Mar. 24, 2014
HORN Antenna SCHWARZBECK	BBHA 9120 D	9120D-969	Jan. 07, 2013	Jan. 06, 2014
HORN Antenna SCHWARZBECK	BBHA 9170	9170-480	Dec. 25, 2012	Dec. 24, 2013
Loop Antenna	HFH2-Z2	100070	Jan. 31, 2012	Jan. 30, 2014
Preamplifier EMCI	EMC 012645	980115	Dec. 28, 2012	Dec. 27, 2013
Preamplifier EMCI	EMC 184045	980116	Dec. 28, 2012	Dec. 27, 2013
Preamplifier EMCI	EMC 330H	980112	Dec. 28, 2012	Dec. 27, 2013
RF signal cable HUBER+SUHNNER	SUCOFLEX 104	309219/4	Oct. 19, 2012	Oct. 18, 2013
RF signal cable HUBER+SUHNNER	SUCOFLEX 104	250130/4	Oct. 19, 2012	Oct. 18, 2013
RF signal cable Worken	RG-213	NA	Dec. 29, 2012	Dec. 28, 2013
Software	E3 6.120103	NA	NA	NA
Antenna Tower MF	MFA-440H	NA	NA	NA
Turn Table MF	MFT-201SS	NA	NA	NA
Antenna Tower & Turn Table Controller MF	MF-7802	NA	NA	NA

- NOTE:**
1. The calibration interval of the above test instruments is 12 months and the calibrations are traceable to NML/ROC and NIST/USA.
 2. The calibration interval of the loop antenna is 24 months and the calibrations are traceable to NML/ROC and NIST/USA.
 3. The test was performed in HwaYa Chamber 10.
 4. The horn antenna and HP preamplifier (model: 8449B) are used only for the measurement of emission frequency above 1GHz if tested.
 5. The FCC Site Registration No. is 690701.
 6. The IC Site Registration No. is IC 7450F-10.

4.1.4 TEST PROCEDURES

- a. The EUT was placed on the top of a rotating table 0.8 meters above the ground at a 3 meter semi-anechoic chamber. The table was rotated 360 degrees to determine the position of the highest radiation.
- b. The EUT was set 3 meters away from the interference-receiving antenna, which was mounted on the top of a variable-height antenna tower.
- c. The antenna is a broadband antenna, and its height is varied from one meter to four meters above the ground to determine the maximum value of the field strength. Both horizontal and vertical polarizations of the antenna are set to make the measurement.
- d. For each suspected emission, the EUT was arranged to its worst case and then the antenna was tuned to heights from 1 meter to 4 meters and the rotatable table was turned from 0 degrees to 360 degrees to find the maximum reading.
- e. The test-receiver system was set to Peak Detect Function and Specified Bandwidth with Maximum Hold Mode.
- f. If the emission level of the EUT in peak mode was 10dB lower than the limit specified, then testing could be stopped and the peak values of the EUT would be reported. Otherwise the emissions that did not have 10dB margin would be re-tested one by one using peak, quasi-peak or average method as specified and then reported in a data sheet.

NOTE:

1. The resolution bandwidth and video bandwidth of test receiver/spectrum analyzer is 120kHz for Peak detection (PK) and Quasi-peak detection (QP) at frequency below 1GHz.
2. The resolution bandwidth of test receiver/spectrum analyzer is 1MHz and video bandwidth is 3MHz for Peak detection at frequency above 1GHz.
3. The resolution bandwidth of test receiver/spectrum analyzer is 1MHz and the video bandwidth is 1kHz for Average detection (AV) at frequency above 1GHz.
4. All modes of operation were investigated and the worst-case emissions are reported.

4.1.5 DEVIATION FROM TEST STANDARD

No deviation.

4.1.6 TEST SETUP

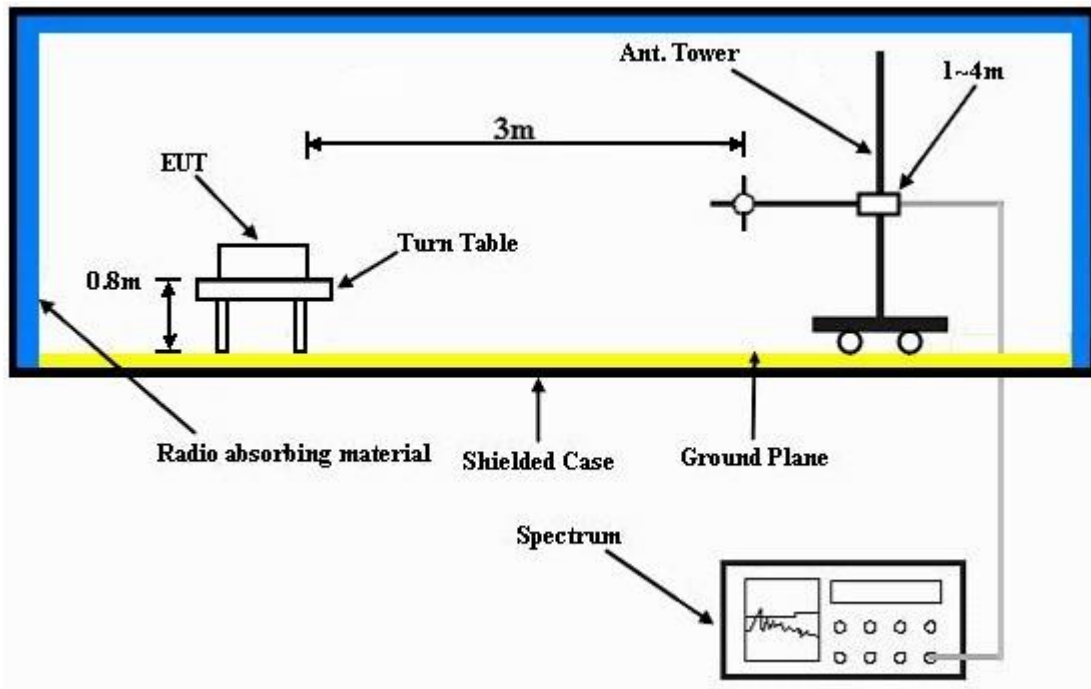

For the actual test configuration, please refer to the attached file (Test Setup Photo).

4.1.7 EUT OPERATING CONDITION

- Placed the EUT on a testing table.
- Use the software to control the EUT under transmission condition continuously at specific channel frequency.



4.1.8 TEST RESULTS

ABOVE 1GHz DATA:

802.11n (40MHz)

EUT TEST CONDITION		MEASUREMENT DETAIL	
CHANNEL	Channel 54	FREQUENCY RANGE	1GHz ~ 40GHz
INPUT POWER (SYSTEM)	120Vac, 60 Hz	DETECTOR FUNCTION	Peak (PK) Average (AV)
ENVIRONMENTAL CONDITIONS	25deg. C, 65%RH	TESTED BY	Anson Lin

ANTENNA POLARITY & TEST DISTANCE: HORIZONTAL AT 3 M										
FREQ. (MHz)	EMISSION LEVEL (dBuV/m)	READ LEVEL (dBuV)	LIMIT (dBuV/m)	MARGIN (dB)	ANTENNA FACTOR (dB/m)	CABLE LOSS (dB)	PREAMP FACTOR (dB)	ANTENNA HEIGHT (cm)	TABLE ANGLE (Degree)	REMARK
5150	45.12	36.53	54	-8.88	34.46	8.13	34	164	283	Average
5150	57.25	48.66	74	-16.75	34.46	8.13	34	164	283	Peak
5270	104.37	95.59			34.5	8.29	34.01	164	283	Average
5270	110.81	102.03			34.5	8.29	34.01	164	283	Peak
5350	45.37	36.52	54	-8.63	34.5	8.38	34.03	164	283	Average
5350	58.33	49.48	74	-15.67	34.5	8.38	34.03	164	283	Peak
ANTENNA POLARITY & TEST DISTANCE: VERTICAL AT 3 M										
FREQ. (MHz)	EMISSION LEVEL (dBuV/m)	READ LEVEL (dBuV)	LIMIT (dBuV/m)	MARGIN (dB)	ANTENNA FACTOR (dB/m)	CABLE LOSS (dB)	PREAMP FACTOR (dB)	ANTENNA HEIGHT (cm)	TABLE ANGLE (Degree)	REMARK
5150	47.43	38.84	54	-6.57	34.46	8.13	34	101	150	Average
5150	59.43	50.84	74	-14.57	34.46	8.13	34	101	150	Peak
5270	106.42	97.64			34.5	8.29	34.01	101	150	Average
5270	112.72	103.94			34.5	8.29	34.01	101	150	Peak
5350	45.52	36.67	54	-8.48	34.5	8.38	34.03	101	150	Average
5350	59.37	50.52	74	-14.63	34.5	8.38	34.03	101	150	Peak

REMARKS: 5270MHz: Fundamental frequency.



A D T

EUT TEST CONDITION		MEASUREMENT DETAIL	
CHANNEL	Channel 62	FREQUENCY RANGE	1GHz ~ 40GHz
INPUT POWER (SYSTEM)	120Vac, 60 Hz	DETECTOR FUNCTION	Peak (PK) Average (AV)
ENVIRONMENTAL CONDITIONS	25deg. C, 65%RH	TESTED BY	Anson Lin

ANTENNA POLARITY & TEST DISTANCE: HORIZONTAL AT 3 M										
FREQ. (MHz)	EMISSION LEVEL (dBuV/m)	READ LEVEL (dBuV)	LIMIT (dBuV/m)	MARGIN (dB)	ANTENNA FACTOR (dB/m)	CABLE LOSS (dB)	PREAMP FACTOR (dB)	ANTENNA HEIGHT (cm)	TABLE ANGLE (Degree)	REMARK
5150	43.08	34.49	54	-10.92	34.46	8.13	34	158	287	Average
5150	55.54	46.95	74	-18.46	34.46	8.13	34	158	287	Peak
5310	99.43	90.63			34.5	8.32	34.02	158	287	Average
5310	106.43	97.63			34.5	8.32	34.02	158	287	Peak
5350	50.51	41.66	54	-3.49	34.5	8.38	34.03	164	246	Average
5350	62.31	53.46	74	-11.69	34.5	8.38	34.03	164	246	Peak
ANTENNA POLARITY & TEST DISTANCE: VERTICAL AT 3 M										
FREQ. (MHz)	EMISSION LEVEL (dBuV/m)	READ LEVEL (dBuV)	LIMIT (dBuV/m)	MARGIN (dB)	ANTENNA FACTOR (dB/m)	CABLE LOSS (dB)	PREAMP FACTOR (dB)	ANTENNA HEIGHT (cm)	TABLE ANGLE (Degree)	REMARK
5150	45.01	36.42	54	-8.99	34.46	8.13	34	100	152	Average
5150	56.29	47.7	74	-17.71	34.46	8.13	34	100	152	Peak
5310	101.51	92.71			34.5	8.32	34.02	100	152	Average
5310	108.01	99.21			34.5	8.32	34.02	100	152	Peak
5350	53.53	44.68	54	-0.47	34.5	8.38	34.03	100	323	Average
5350	65.08	56.23	74	-8.92	34.5	8.38	34.03	100	323	Peak

REMARKS: 5310MHz: Fundamental frequency.



EUT TEST CONDITION		MEASUREMENT DETAIL	
CHANNEL	Channel 102	FREQUENCY RANGE	1GHz ~ 40GHz
INPUT POWER (SYSTEM)	120Vac, 60 Hz	DETECTOR FUNCTION	Peak (PK) Average (AV)
ENVIRONMENTAL CONDITIONS	25deg. C, 65%RH	TESTED BY	Anson Lin

ANTENNA POLARITY & TEST DISTANCE: HORIZONTAL AT 3 M

FREQ. (MHz)	EMISSION LEVEL (dBuV/m)	READ LEVEL (dBuV)	LIMIT (dBuV/m)	MARGIN (dB)	ANTENNA FACTOR (dB/m)	CABLE LOSS (dB)	PREAMP FACTOR (dB)	ANTENNA HEIGHT (cm)	TABLE ANGLE (Degree)	REMARK
5460	44.22	35.26	54	-9.78	34.5	8.51	34.05	166	278	Average
5460	58.81	49.85	74	-15.19	34.5	8.51	34.05	166	278	Peak
5470	61.74	52.78	68.3	-6.56	34.5	8.51	34.05	157	244	Peak
5510	98.62	89.6			34.51	8.57	34.06	166	278	Average
5510	106.35	97.33			34.51	8.57	34.06	166	278	Peak
5725	56.17	46.96	68.3	-12.13	34.67	8.65	34.11	166	278	Peak

ANTENNA POLARITY & TEST DISTANCE: VERTICAL AT 3 M

FREQ. (MHz)	EMISSION LEVEL (dBuV/m)	READ LEVEL (dBuV)	LIMIT (dBuV/m)	MARGIN (dB)	ANTENNA FACTOR (dB/m)	CABLE LOSS (dB)	PREAMP FACTOR (dB)	ANTENNA HEIGHT (cm)	TABLE ANGLE (Degree)	REMARK
5460	49.37	40.41	54	-4.63	34.5	8.51	34.05	173	176	Average
5460	64.58	55.62	74	-9.42	34.5	8.51	34.05	173	176	Peak
5470	66.78	57.82	68.3	-1.52	34.5	8.51	34.05	101	360	Peak
5510	101.84	92.82			34.51	8.57	34.06	173	176	Average
5510	108.79	99.77			34.51	8.57	34.06	173	176	Peak
5725	56.3	47.09	68.3	-12	34.67	8.65	34.11	173	176	Peak

REMARKS:

- 5510MHz: Fundamental frequency.
- 5470MHz & 5725MHz: Out of restricted band



EUT TEST CONDITION		MEASUREMENT DETAIL	
CHANNEL	Channel 110	FREQUENCY RANGE	1GHz ~ 40GHz
INPUT POWER (SYSTEM)	120Vac, 60 Hz	DETECTOR FUNCTION	Peak (PK) Average (AV)
ENVIRONMENTAL CONDITIONS	25deg. C, 65%RH	TESTED BY	Anson Lin

ANTENNA POLARITY & TEST DISTANCE: HORIZONTAL AT 3 M										
FREQ. (MHz)	EMISSION LEVEL (dBuV/m)	READ LEVEL (dBuV)	LIMIT (dBuV/m)	MARGIN (dB)	ANTENNA FACTOR (dB/m)	CABLE LOSS (dB)	PREAMP FACTOR (dB)	ANTENNA HEIGHT (cm)	TABLE ANGLE (Degree)	REMARK
5460	45.29	36.33	54	-8.71	34.5	8.51	34.05	101	280	Average
5460	58.76	49.8	74	-15.24	34.5	8.51	34.05	101	280	Peak
5470	60.01	51.05	68.3	-8.29	34.5	8.51	34.05	101	280	Peak
5550	100.99	91.93			34.54	8.59	34.07	101	280	Average
5550	108.71	99.65			34.54	8.59	34.07	101	280	Peak
5725	57.51	48.3	68.3	-10.79	34.67	8.65	34.11	101	280	Peak
ANTENNA POLARITY & TEST DISTANCE: VERTICAL AT 3 M										
FREQ. (MHz)	EMISSION LEVEL (dBuV/m)	READ LEVEL (dBuV)	LIMIT (dBuV/m)	MARGIN (dB)	ANTENNA FACTOR (dB/m)	CABLE LOSS (dB)	PREAMP FACTOR (dB)	ANTENNA HEIGHT (cm)	TABLE ANGLE (Degree)	REMARK
5460	47.15	38.19	54	-6.85	34.5	8.51	34.05	187	176	Average
5460	60.28	51.32	74	-13.72	34.5	8.51	34.05	187	176	Peak
5470	60.03	51.07	68.3	-8.27	34.5	8.51	34.05	187	176	Peak
5550	105.53	96.47			34.54	8.59	34.07	187	176	Average
5550	113.32	104.26			34.54	8.59	34.07	187	176	Peak
5725	58.82	49.61	68.3	-9.48	34.67	8.65	34.11	187	176	Peak

REMARKS:

- 5550MHz: Fundamental frequency.
- 5470MHz & 5725MHz: Out of restricted band



EUT TEST CONDITION		MEASUREMENT DETAIL	
CHANNEL	Channel 134	FREQUENCY RANGE	1GHz ~ 40GHz
INPUT POWER (SYSTEM)	120Vac, 60 Hz	DETECTOR FUNCTION	Peak (PK) Average (AV)
ENVIRONMENTAL CONDITIONS	25deg. C, 65%RH	TESTED BY	Anson Lin

ANTENNA POLARITY & TEST DISTANCE: HORIZONTAL AT 3 M										
FREQ. (MHz)	EMISSION LEVEL (dBuV/m)	READ LEVEL (dBuV)	LIMIT (dBuV/m)	MARGIN (dB)	ANTENNA FACTOR (dB/m)	CABLE LOSS (dB)	PREAMP FACTOR (dB)	ANTENNA HEIGHT (cm)	TABLE ANGLE (Degree)	REMARK
5460	45.12	36.16	54	-8.88	34.5	8.51	34.05	100	360	Average
5460	58.08	49.12	74	-15.92	34.5	8.51	34.05	100	360	Peak
5470	58.95	49.99	68.3	-9.35	34.5	8.51	34.05	100	360	Peak
5670	104.08	94.92			34.63	8.63	34.1	100	360	Average
5670	101.31	92.15			34.63	8.63	34.1	100	360	Peak
5725	57.98	48.77	68.3	-10.32	34.67	8.65	34.11	100	360	Peak
ANTENNA POLARITY & TEST DISTANCE: VERTICAL AT 3 M										
FREQ. (MHz)	EMISSION LEVEL (dBuV/m)	READ LEVEL (dBuV)	LIMIT (dBuV/m)	MARGIN (dB)	ANTENNA FACTOR (dB/m)	CABLE LOSS (dB)	PREAMP FACTOR (dB)	ANTENNA HEIGHT (cm)	TABLE ANGLE (Degree)	REMARK
5460	45.55	36.59	54	-8.45	34.5	8.51	34.05	166	214	Average
5460	59.24	50.28	74	-14.76	34.5	8.51	34.05	166	214	Peak
5470	59.34	50.38	68.3	-8.96	34.5	8.51	34.05	166	214	Peak
5670	106.06	96.9			34.63	8.63	34.1	166	214	Average
5670	113.37	104.21			34.63	8.63	34.1	166	214	Peak
5725	62.69	53.48	68.3	-5.61	34.67	8.65	34.11	166	214	Peak

REMARKS:

- 5670MHz: Fundamental frequency.
- 5470MHz & 5725MHz: Out of restricted band



BELOW 1GHz WORST-CASE DATA : 802.11n (40MHz)

EUT TEST CONDITION		MEASUREMENT DETAIL	
CHANNEL	Channel 54	FREQUENCY RANGE	30MHz ~ 1GHz
INPUT POWER (SYSTEM)	120Vac, 60 Hz	DETECTOR FUNCTION	Peak (PK) Quasi-Peak (QP)
ENVIRONMENTAL CONDITIONS	25deg. C, 65%RH	TESTED BY	Anson Lin

ANTENNA POLARITY & TEST DISTANCE: HORIZONTAL AT 3 M										
FREQ. (MHz)	EMISSION LEVEL (dBuV/m)	READ LEVEL (dBuV)	LIMIT (dBuV/m)	MARGIN (dB)	ANTENNA FACTOR (dB/m)	CABLE LOSS (dB)	PREAMP FACTOR (dB)	ANTENNA HEIGHT (cm)	TABLE ANGLE (Degree)	REMARK
75.09	22.51	43.69	40	-17.49	9.57	0.93	31.68	100	118	Peak
150.15	22.87	40.43	43.5	-20.63	12.71	1.34	31.61	100	325	Peak
275.16	26.68	44.44	46	-19.32	12.22	1.94	31.92	100	146	Peak
351.1	37.09	52.54	46	-8.91	14.17	2.23	31.85	100	121	Peak
675.2	37.09	45.07	46	-8.91	20.51	3.34	31.83	100	130	Peak
799.8	35.3	40.81	46	-10.7	22.23	3.69	31.43	100	184	Peak
ANTENNA POLARITY & test distance: VERTICAL at 3 m										
FREQ. (MHz)	EMISSION LEVEL (dBuV/m)	READ LEVEL (dBuV)	LIMIT (dBuV/m)	MARGIN (dB)	ANTENNA FACTOR (dB/m)	CABLE LOSS (dB)	PREAMP FACTOR (dB)	ANTENNA HEIGHT (cm)	TABLE ANGLE (Degree)	REMARK
31.62	32.42	50.65	40	-7.58	12.3	0.58	31.11	100	195	Peak
58.08	26.92	45.31	40	-13.08	12.15	0.81	31.35	100	174	Peak
299.46	25.41	42.26	46	-20.59	12.94	2.05	31.84	100	178	Peak
479.9	33.43	45.64	46	-12.57	16.93	2.71	31.85	100	147	Peak
624.8	33.7	42.8	46	-12.3	19.9	3.16	32.16	100	158	Peak
836.9	32.84	38.13	46	-13.16	22.7	3.79	31.78	100	174	Peak



A D T

EUT TEST CONDITION		MEASUREMENT DETAIL	
CHANNEL	Channel 134	FREQUENCY RANGE	30MHz ~ 1GHz
INPUT POWER (SYSTEM)	120Vac, 60 Hz	DETECTOR FUNCTION	Peak (PK) Quasi-Peak (QP)
ENVIRONMENTAL CONDITIONS	25deg. C, 65%RH	TESTED BY	Anson Lin

ANTENNA POLARITY & TEST DISTANCE: HORIZONTAL AT 3 M										
FREQ. (MHz)	EMISSION LEVEL (dBuV/m)	READ LEVEL (dBuV)	LIMIT (dBuV/m)	MARGIN (dB)	ANTENNA FACTOR (dB/m)	CABLE LOSS (dB)	PREAMP FACTOR (dB)	ANTENNA HEIGHT (cm)	TABLE ANGLE (Degree)	REMARK
75.09	26.71	47.89	40	-13.29	9.57	0.93	31.68	100	26	Peak
224.94	25.01	44.65	46	-20.99	10.42	1.72	31.78	100	123	Peak
298.38	33.01	49.87	46	-12.99	12.91	2.05	31.82	100	145	Peak
351.1	34.79	50.24	46	-11.21	14.17	2.23	31.85	100	341	Peak
451.2	35.19	48.2	46	-10.81	16.35	2.62	31.98	100	184	Peak
750.1	36.99	43.2	46	-9.01	21.52	3.57	31.3	100	139	Peak
ANTENNA POLARITY & test distance: VERTICAL at 3 m										
FREQ. (MHz)	EMISSION LEVEL (dBuV/m)	READ LEVEL (dBuV)	LIMIT (dBuV/m)	MARGIN (dB)	ANTENNA FACTOR (dB/m)	CABLE LOSS (dB)	PREAMP FACTOR (dB)	ANTENNA HEIGHT (cm)	TABLE ANGLE (Degree)	REMARK
31.84	34.78	53.01	40	-5.22	12.3	0.58	31.11	100	132	QP
145.56	26.35	44.11	43.5	-17.15	12.54	1.32	31.62	100	136	Peak
209.82	21.15	41.35	43.5	-22.35	9.77	1.64	31.61	100	184	Peak
566.7	36.11	46.35	46	-9.89	18.84	2.99	32.07	100	152	Peak
675.2	35.68	43.66	46	-10.32	20.51	3.34	31.83	100	135	Peak
729.1	34.47	41.32	46	-11.53	21.23	3.52	31.6	100	117	Peak



A D T

4.2 CONDUCTED EMISSION MEASUREMENT

4.2.1 LIMITS OF CONDUCTED EMISSION MEASUREMENT

FREQUENCY OF EMISSION (MHz)	CONDUCTED LIMIT (dB μ V)	
	Quasi-peak	Average
0.15 ~ 0.5	66 to 56	56 to 46
0.5 ~ 5	56	46
5 ~ 30	60	50

- NOTE:** 1. The lower limit shall apply at the transition frequencies.
2. The limit decreases in line with the logarithm of the frequency in the range of 0.15 to 0.50MHz.
3. All emanations from a class A/B digital device or system, including any network of conductors and apparatus connected thereto, shall not exceed the level of field strengths specified above.

4.2.2 TEST INSTRUMENTS

DESCRIPTION & MANUFACTURER	MODEL NO.	SERIAL NO.	DATE OF CALIBRATION	DUE DATE OF CALIBRATION
Test Receiver ROHDE & SCHWARZ	ESCS30	100288	Nov. 09, 2012	Nov. 08, 2013
RF signal cable Woken	5D-FB	Cable-HYCO2-01	Dec. 28, 2012	Dec. 27, 2013
LISN ROHDE & SCHWARZ (EUT)	ESH2-Z5	100100	Dec. 21, 2012	Dec. 20, 2013
LISN ROHDE & SCHWARZ (Peripheral)	ESH3-Z5	100312	Jul. 02, 2013	Jul. 01, 2014
Software ADT	BV ADT_Cond_ V7.3.7.3	NA	NA	NA

- NOTE:** 1. The calibration interval of the above test instruments is 12 months and the calibrations are traceable to NML/ROC and NIST/USA.
2. The test was performed in HwaYa Shielded Room 2.
3. The VCCI Site Registration No. is C-2047.

4.2.3 TEST PROCEDURES

- The EUT was placed 0.4 meters from the conducting wall of the shielded room with EUT being connected to the power mains through a line impedance stabilization network (LISN). Other support units were connected to the power mains through another LISN. The two LISNs provide 50 ohm/ 50uH of coupling impedance for the measuring instrument.
- Both lines of the power mains connected to the EUT were checked for maximum conducted interference.
- The frequency range from 150kHz to 30MHz was searched. Emission levels under (Limit - 20dB) was not recorded.

NOTE: All modes of operation were investigated and the worst-case emissions are reported.

4.2.4 DEVIATION FROM TEST STANDARD

No deviation.

4.2.5 TEST SETUP

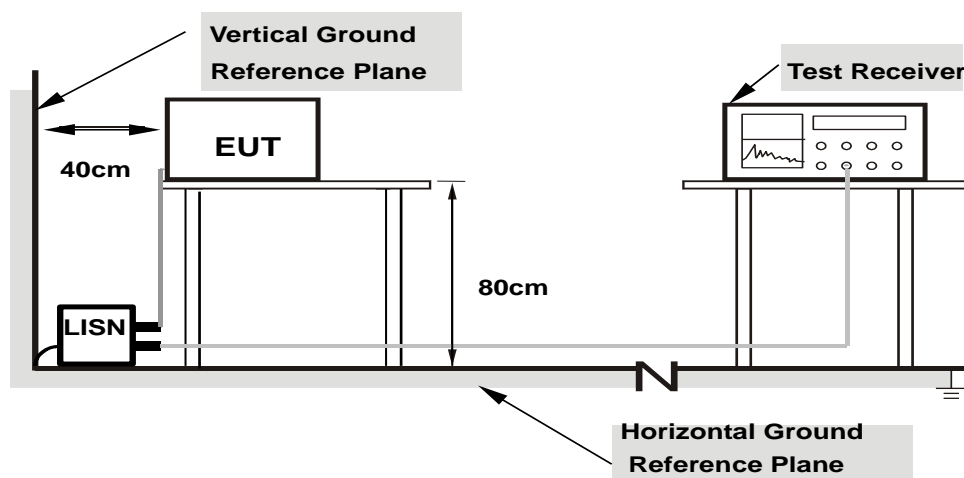

- Note:**
- Support units were connected to second LISN.
 - Both of LISNs (AMN) are 80 cm from EUT and at least 80 from other units and other metal planes

For the actual test configuration, please refer to the attached file (Test Setup Photo).

4.2.6 EUT OPERATING CONDITIONS

Same as 4.1.6.

4.2.7 TEST RESULTS

CONDUCTED WORST-CASE DATA : 802.11n (40MHz)

PHASE	Line 1	6dB BANDWIDTH	9kHz
--------------	--------	----------------------	------

No	Freq. [MHz]	Corr. Factor (dB)	Reading Value [dB (uV)]		Emission Level [dB (uV)]		Limit [dB (uV)]		Margin (dB)	
			Q.P.	AV.	Q.P.	AV.	Q.P.	AV.	Q.P.	AV.
			1	0.22031	0.17	34.24	22.87	34.41	23.04	62.81
2	0.38438	0.21	35.48	30.08	35.69	30.29	58.18	48.18	-22.50	-17.90
3	0.77109	0.25	32.62	25.52	32.87	25.77	56.00	46.00	-23.13	-20.23
4	2.26172	0.29	29.92	23.66	30.21	23.95	56.00	46.00	-25.79	-22.05
5	6.85156	0.40	27.52	21.61	27.92	22.01	60.00	50.00	-32.08	-27.99
6	13.55469	0.50	31.26	25.80	31.76	26.30	60.00	50.00	-28.24	-23.70

REMARKS:

1. Q.P. and AV. are abbreviations of quasi-peak and average individually.
2. The emission levels of other frequencies were very low against the limit.
3. Margin value = Emission level - Limit value
4. Correction factor = Insertion loss + Cable loss
5. Emission Level = Correction Factor + Reading Value

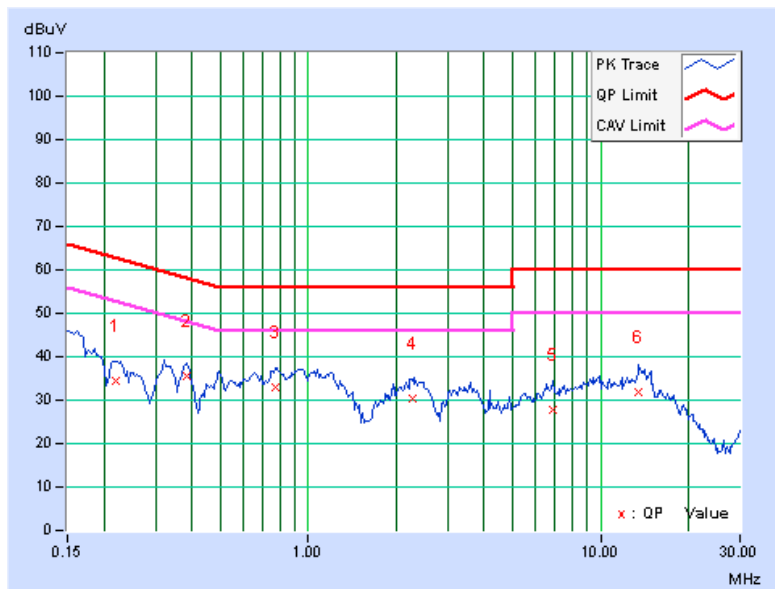

PHASE	Line 2	6dB BANDWIDTH	9kHz
-------	--------	---------------	------

No	Freq. [MHz]	Corr. Factor (dB)	Reading Value		Emission Level		Limit		Margin	
			[dB (uV)]		[dB (uV)]		[dB (uV)]		(dB)	
			Q.P.	AV.	Q.P.	AV.	Q.P.	AV.	Q.P.	AV.
1	0.22422	0.19	39.24	31.24	39.43	31.43	62.66	52.66	-23.23	-21.23
2	0.32578	0.22	34.69	20.77	34.91	20.99	59.56	49.56	-24.64	-28.56
3	0.77891	0.24	27.23	18.37	27.47	18.61	56.00	46.00	-28.53	-27.39
4	2.37109	0.30	28.17	21.01	28.47	21.31	56.00	46.00	-27.53	-24.69
5	4.79688	0.40	23.86	17.43	24.26	17.83	56.00	46.00	-31.74	-28.17
6	14.61328	0.60	35.53	29.95	36.13	30.55	60.00	50.00	-23.87	-19.45

REMARKS:

1. Q.P. and AV. are abbreviations of quasi-peak and average individually.
2. The emission levels of other frequencies were very low against the limit.
3. Margin value = Emission level - Limit value
4. Correction factor = Insertion loss + Cable loss
5. Emission Level = Correction Factor + Reading Value

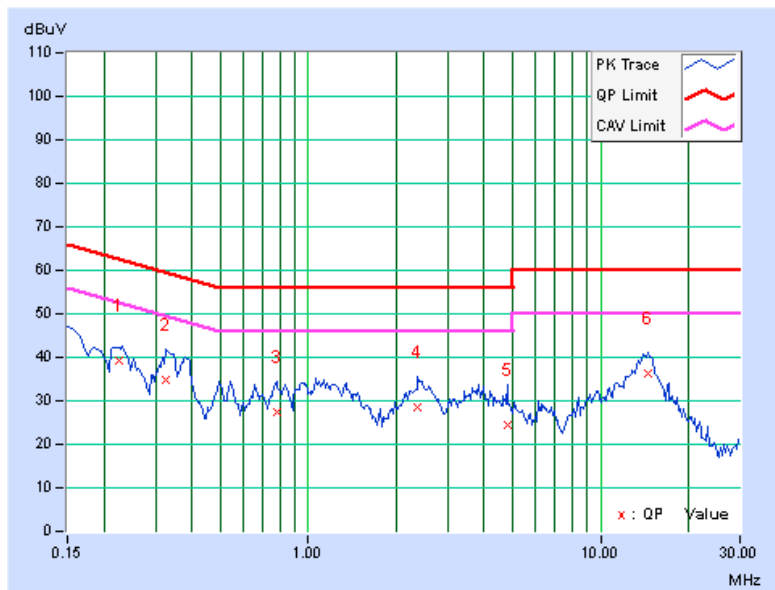

4.3 PEAK TRANSMIT POWER MEASUREMENT

4.3.1 LIMITS OF PEAK TRANSMIT POWER MEASUREMENT

FREQUENCY BAND	LIMIT
5.250 ~ 5.350GHz	The lesser of 250mW (24dBm) or 11dBm + 10logB
5.470 ~ 5.725GHz	The lesser of 250mW (24dBm) or 11dBm + 10logB

NOTE: Where B is the 26dB emission bandwidth in MHz.

Per KDB 662911 D01 Multiple Transmitter Output v01r02 Method of conducted output power measurement on IEEE 802.11 devices,

Array Gain = 0 dB (i.e., no array gain) for NANT ≤ 4;

Array Gain = 0 dB (i.e., no array gain) for channel widths ≥ 40 MHz for any NANT;

Array Gain = 5 log(NANT/NSS) dB or 3 dB, whichever is less for 20-MHz channel widths with NANT ≥ 5.

For power measurements on all other devices: Array Gain = 10 log(NANT/NSS) dB.

4.3.2 TEST SETUP

FOR POWER OUTPUT MEASUREMENT

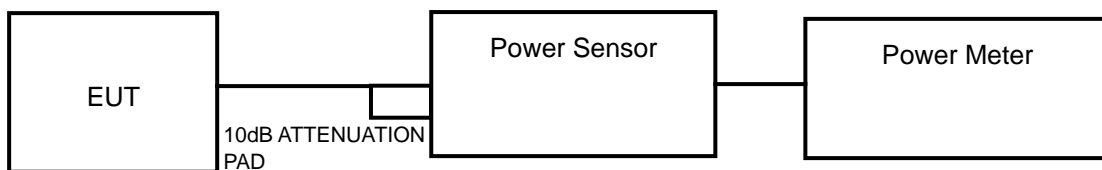

FOR 26dB BANDWIDTH

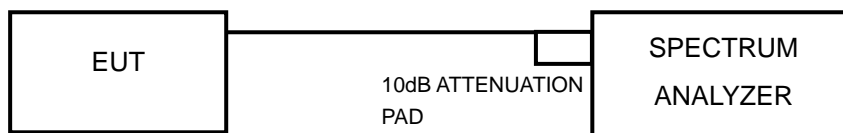

4.3.3 TEST INSTRUMENTS

Refer to section 4.1.3 to get information of above instrument.

4.3.4 TEST PROCEDURE

FOR AVERAGE POWER MEASUREMENT

Method PM is used to perform output power measurement, trigger and gating function of wide band power meter is enabled to measure max output power of TX on burst. Duty factor is not added to measured value.

FOR 26dB BANDWIDTH

- 1) Set RBW = approximately 1% of the emission bandwidth.
- 2) Set the VBW > RBW.
- 3) Detector = Peak.
- 4) Trace mode = max hold.
- 5) Measure the maximum width of the emission that is 26 dB down from the peak of the emission. Compare this with the RBW setting of the analyzer. Readjust RBW and repeat measurement as needed until the RBW/EBW ratio is approximately 1%.

4.3.5 DEVIATION FROM TEST STANDARD

No deviation.

4.3.6 EUT OPERATING CONDITIONS

The software provided by client to enable the EUT under transmission condition continuously at specific channel frequencies individually.



4.3.7 TEST RESULTS

POWER OUTPUT:

802.11n (40MHz)

CH.	CHAN. FREQ. (MHz)	AVERAGE POWER (dBm)				TOTAL POWER (mW)	TOTAL POWER (dBm)	POWER LIMIT (dBm)	PASS / FAIL
		CHAIN 0	CHAIN 1	CHAIN 2	CHAIN 3				
54	5270	17.46	16.91	17.68	17.03	213.796	23.30	24	PASS
62	5310	12.91	12.5	13.21	12.35	75.509	18.78	24	PASS
102	5510	16.64	16.54	16.85	16.34	182.810	22.62	24	PASS
110	5550	16.68	16.48	16.74	16.42	181.970	22.60	24	PASS
134	5670	16.65	16.49	16.97	16.47	184.927	22.67	24	PASS

26dB BANDWIDTH:

802.11n (40MHz)

CH.	CHANNEL FREQUENCY (MHz)	26dBc BANDWIDTH (MHz)				PASS / FAIL
		chain 0	chain 1	CHAIN 2	CHAIN 3	
54	5270	60.46	52.55	60.47	50.78	PASS
62	5310	44.56	44.21	44.74	44.33	PASS
102	5510	53.03	55.33	60.11	50.35	PASS
110	5550	56.99	52.37	60.20	50.67	PASS
134	5670	52.94	50.66	54.91	50.81	PASS

4.4 PEAK POWER SPECTRAL DENSITY MEASUREMENT

4.4.1 LIMITS OF PEAK POWER SPECTRAL DENSITY MEASUREMENT

FREQUENCY BAND	LIMIT
5.250 ~ 5.350GHz	11dBm
5.470 ~ 5.725GHz	11dBm

4.4.2 TEST SETUP

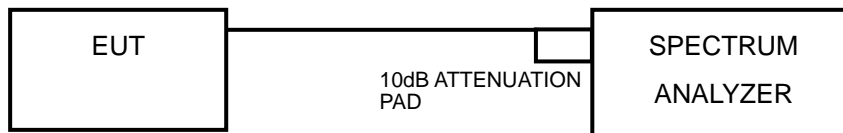

4.4.3 TEST INSTRUMENTS

Refer to section 4.1.3 to get information of above instrument.

4.4.4 TEST PROCEDURES

Using method SA-2 alternative

- 1) Set span to encompass the entire emission bandwidth (EBW) of the signal.
- 2) Set RBW = 30 kHz, Set VBW \geq 1 MHz, Detector = RMS
- 3) Set Channel power measure = 1MHz
- 4) Sweep time = 30ms
- 5) Perform a single sweep.
- 6) Record the max value and add 10 log (1/duty cycle)



4.4.5 DEVIATION FROM TEST STANDARD

No deviation.

4.4.6 EUT OPERATING CONDITIONS

Same as 4.3.6.

4.4.7 TEST RESULTS

For 5270 ~ 5310 MHz

802.11n (40MHz)

CH.	CHAN. FREQ. (MHz)	PSD W/O DUTY FACTOR (dBm)				DUTY FACTOR	PSD W/ DUTY FACTOR (dBm)				TOTAL PSD WITH DUTY FACTOR (dBm)	MAX. LIMIT (dBm)	PASS / FAIL
		CHAIN 0	CHAIN 1	CHAIN 2	CHAIN 3		CHAIN 0	CHAIN 1	CHAIN 2	CHAIN 3			
54	5270	2.08	1.86	2.09	1.88	0.19	2.27	2.05	2.28	2.07	8.19	9.33	PASS
62	5310	-1.95	-2.76	-2.36	-2.54	0.19	-1.76	-2.57	-2.17	-2.35	3.81	9.33	PASS

NOTE:

1. Method 1 of power density measurement of KDB 662911 is using for calculating total power density. Total power density is summing entire spectra across corresponding frequency bins on the various outputs by computer.
2. Directional gain = $1.65\text{dBi} + 10\log(4) = 7.67\text{dBi} > 6\text{dBi}$, so the power density limit shall be reduced to $11-(7.67-6) = 9.33\text{dBm}$.
3. Refer to section 3.3 for duty cycle spectrum plot.



For 5510 ~ 5670 MHz

802.11n (40MHz)

CH.	CHAN. FREQ. (MHz)	PSD W/O DUTY FACTOR (dBm)				DUTY FACTOR	PSD W/ DUTY FACTOR (dBm)				TOTAL PSD WITH DUTY FACTOR (dBm)	MAX. LIMIT (dBm)	PASS / FAIL
		CHAIN 0	CHAIN 1	CHAIN 2	CHAIN 3		CHAIN 0	CHAIN 1	CHAIN 2	CHAIN 3			
102	5510	1.87	1.74	2.40	1.47	0.19	2.06	1.93	2.59	1.66	8.09	8.24	PASS
110	5550	2.11	1.65	2.32	1.70	0.19	2.30	1.84	2.51	1.89	8.16	8.24	PASS
134	5670	1.87	1.37	1.97	1.48	0.19	2.06	1.56	2.16	1.67	7.89	8.24	PASS

NOTE:

1. Method 1 of power density measurement of KDB 662911 is using for calculating total power density. Total power density is summing entire spectra across corresponding frequency bins on the various outputs by computer.
2. Directional gain = $2.74\text{dBi} + 10\log(4) = 8.76\text{dBi} > 6\text{dBi}$, so the power density limit shall be reduced to $11 - (8.76 - 6) = 8.24\text{dBm}$.
3. Refer to section 3.3 for duty cycle spectrum plot.

4.5 PEAK POWER EXCURSION MEASUREMENT

4.5.1 LIMITS OF PEAK POWER EXCURSION MEASUREMENT

Shall not exceed 13 dB.

4.5.2 TEST SETUP

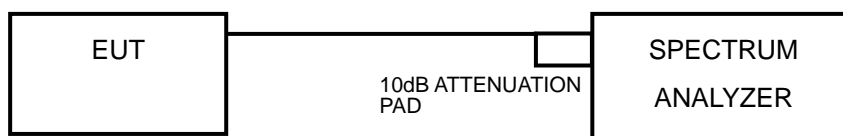

4.5.3 TEST INSTRUMENTS

Refer to section 4.1.3 to get information of above instrument.

4.5.4 TEST PROCEDURE

- 1) Set RBW = 1 MHz, VBW \geq 3 MHz, Detector = peak.
- 2) Trace mode = max-hold. Allow the sweeps to continue until the trace stabilizes.
- 3) Use the peak search function to find the peak of the spectrum.
- 4) Measure the PPSD.
- 5) Compute the ratio of the maximum of the peak-max-hold spectrum to the PPSD.

4.5.5 DEVIATION FROM TEST STANDARD

No deviation.

4.5.6 EUT OPERATING CONDITIONS

Same as 4.2.6

4.5.7 TEST RESULTS

802.11n (40MHz)

Modulation Mode	Modulation type	Channel Frequency (MHz)	PEAK VALUE (dBm)				PPSD WITHOUT DUTY FACTOR (dBm)			
			CHAIN 0	CHAIN 1	CHAIN 2	CHAIN 3	CHAIN 0	CHAIN 1	CHAIN 2	CHAIN 3
HT 40_MCS0	BPSK	5270	11.11	10.81	10.91	10.88	2.08	1.86	2.09	1.88
	QPSK		11.26	10.84	10.80	10.94	1.99	1.72	2.34	1.61
	16QAM		11.12	10.99	11.32	10.78	1.84	1.55	2.31	1.53
	64QAM		12.29	12.13	12.88	11.58	1.79	1.46	1.83	1.59

PPSD WITH DUTY FACTOR (dBm)				PEAK Excursion (dB)				LIMIT (dB)	PASS /FAIL
CHAIN 0	CHAIN 1	CHAIN 2	CHAIN 3	CHAIN 0	CHAIN 1	CHAIN 2	CHAIN 3		
2.27	2.05	2.28	2.07	8.84	8.76	8.63	8.81	13	PASS
2.18	1.91	2.53	1.80	9.08	8.93	8.27	9.14	13	PASS
2.03	1.74	2.50	1.72	9.09	9.25	8.82	9.06	13	PASS
1.98	1.65	2.02	1.78	10.31	10.48	10.86	9.80	13	PASS

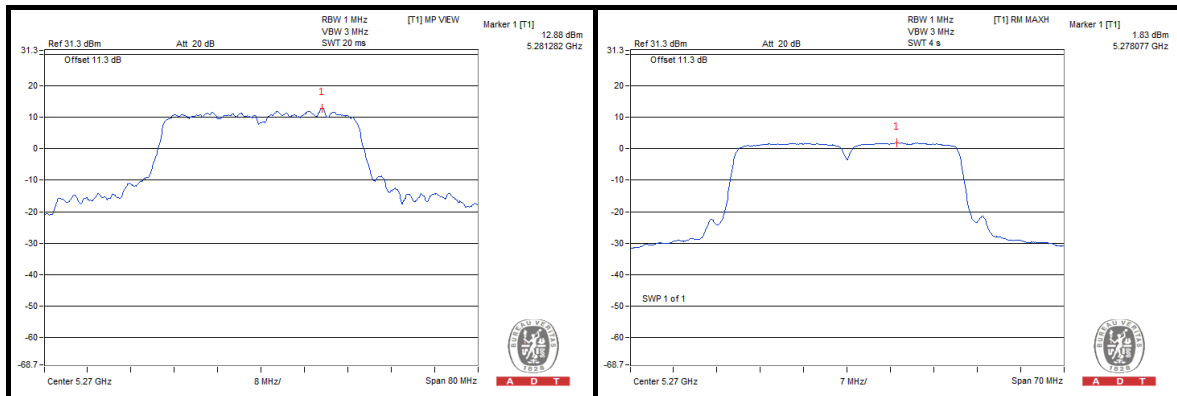

4.6 FREQUENCY STABILITY

4.6.1 LIMITS OF FREQUENCY STABILITY MEASUREMENT

The frequency of the carrier signal shall be maintained within band of operation

4.6.2 TEST SETUP

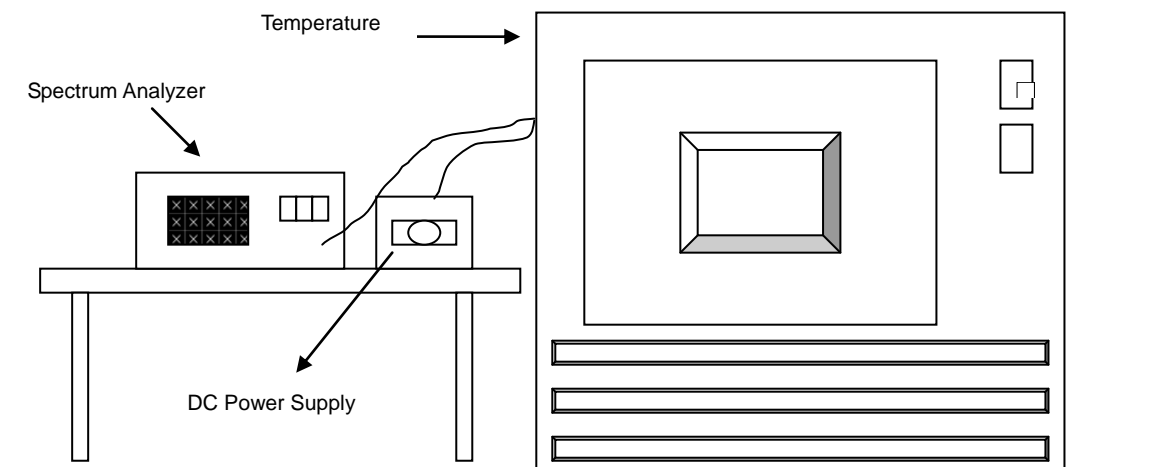

4.6.3 TEST INSTRUMENTS

Refer to section 4.1.3 to get information of above instrument.

4.6.4 TEST PROCEDURE

- a. To ensure emission at the band edge is maintained within the authorized band, those values shall be measured by radiation emissions at upper and lower frequency points, and finally compensated by frequency deviation as procedures below.
- b. The EUT was operated at the maximum output power, and connected to the spectrum analyzer, which is set to maximum hold function and peak detector. The peak value of the power envelope was measured and noted. The upper and lower frequency points were respectively measured relatively 10dB lower than the measured peak value.
- c. The frequency deviation was calculated by adding the upper frequency point and the lower frequency point divided by two. Those detailed values of frequency deviation are provided in table below.

4.6.5 DEVIATION FROM TEST STANDARD

No deviation.

4.6.6 EUT OPERATING CONDITION

Set the EUT transmit at un-modulation mode to test frequency stability.



4.6.7 TEST RESULTS

FREQUENCY STABILITY VERSUS TEMP.									
OPERATING FREQUENCY: 5310MHz									
TEMP. (°C)	POWER SUPPLY (Vdc)	0 MINUTE		2 MINUTE		5 MINUTE		10 MINUTE	
		Measured Frequency (MHz)	Frequency Drift (ppm)	Measured Frequency (MHz)	Frequency Drift (ppm)	Measured Frequency (MHz)	Frequency Drift (ppm)	Measured Frequency (MHz)	Frequency Drift (ppm)
50	12.0	5310.063302	11.921	5310.064071	12.066	5310.063393	11.938	5310.064223	12.095
40	12.0	5310.064135	12.078	5310.064212	12.093	5310.064253	12.100	5310.064247	12.099
30	12.0	5310.065566	12.348	5310.065425	12.321	5310.065425	12.321	5310.065107	12.261
20	12.0	5310.072480	13.650	5310.072071	13.573	5310.072296	13.615	5310.072168	13.591
10	12.0	5310.067648	12.740	5310.067619	12.734	5310.067624	12.735	5310.067487	12.709
0	12.0	5310.066198	12.467	5310.066092	12.447	5310.066202	12.467	5310.066538	12.531
-10	12.0	5310.064439	12.135	5310.064708	12.186	5310.064697	12.184	5310.064469	12.141
-20	12.0	5310.064138	12.079	5310.064662	12.177	5310.063971	12.047	5310.064511	12.149
-30	12.0	5310.063110	11.885	5310.063080	11.879	5310.063439	11.947	5310.063386	11.937

FREQUENCY STABILITY VERSUS VOLTAGE									
OPERATING FREQUENCY: 5310MHz									
TEMP. (°C)	POWER SUPPLY (Vac)	0 MINUTE		2 MINUTE		5 MINUTE		10 MINUTE	
		Measured Frequency (MHz)	Frequency Drift (ppm)	Measured Frequency (MHz)	Frequency Drift (ppm)	Measured Frequency (MHz)	Frequency Drift (ppm)	Measured Frequency (MHz)	Frequency Drift (ppm)
20	10.8	5310.071343	13.436	5310.071909	13.542	5310.071507	13.466	5310.071839	13.529
	12.0	5310.072480	13.650	5310.072071	13.573	5310.072296	13.615	5310.072168	13.591
	12.6	5310.074114	13.957	5310.073834	13.905	5310.073976	13.931	5310.073745	13.888



A D T

5. PHOTOGRAPHS OF THE TEST CONFIGURATION

Please refer to the attached file (Test Setup Photo).

6. INFORMATION ON THE TESTING LABORATORIES

We, Bureau Veritas Consumer Products Services (H.K.) Ltd., Taoyuan Branch, were founded in 1988 to provide our best service in EMC, Radio, Telecom and Safety consultation. Our laboratories are accredited and approved according to ISO/IEC 17025.

If you have any comments, please feel free to contact us at the following:

Linko EMC/RF Lab:

Tel: 886-2-26052180

Fax: 886-2-26051924

Hsin Chu EMC/RF Lab:

Tel: 886-3-5935343

Fax: 886-3-5935342

Hwa Ya EMC/RF/Safety Telecom Lab:

Tel: 886-3-3183232

Fax: 886-3-3270892

Email: service.adt@tw.bureauveritas.com

Web Site: www.bureauveritas-adt.com

The address and road map of all our labs can be found in our web site also.



A D T

7. APPENDIX A - MODIFICATIONS RECORDERS FOR ENGINEERING CHANGES TO THE EUT BY THE LAB

No modifications were made to the EUT by the lab during the test.

---END---