

FCC TEST REPORT  
for  
Shenzhen Samoon Technology Co., Ltd.

SPORT DVR  
Model No.:SHA58S, SHA58

Prepared for : Shenzhen Samoon Technology Co., Ltd.  
Address : Floor 6, Zhongyuntai Industrial Park, Yingrenshi Road Crossing,  
Shiyan Town, Baoan District, Shenzhen, CN

Prepared By : Shenzhen Anbotek Compliance Laboratory Limited  
Address : 1/F., Building 1, SEC Industrial Park, No.0409 Qianhai Road,  
Nanshan District, Shenzhen, Guangdong, China  
Tel: (86) 755-26066544  
Fax: (86) 755-26014772

Report Number : 201307720F  
Date of Test : Sep. 24~ Oct. 16, 2013  
Date of Report : Oct. 16, 2013

**TABLE OF CONTENT**

Description

Page

Test Report

<b>1. GENERAL INFORMATION .....</b>	<b>4</b>
1.1. Description of Device (EUT).....	4
1.2. Description of Test Facility .....	5
1.3. Measurement Uncertainty.....	5
<b>2. TEST METHODOLOGY .....</b>	<b>6</b>
2.1. Summary of Test Results.....	6
2.2. Description of Test Modes.....	6
2.3. List of channels:.....	7
<b>3. CONDUCTED EMISSION TEST.....</b>	<b>8</b>
3.1. Block Diagram of Test Setup .....	8
3.2. Power Line Conducted Emission Measurement Limits (15.207).....	8
3.3. Configuration of EUT on Measurement .....	8
3.4. Operating Condition of EUT .....	8
3.5. Test Procedure .....	9
3.6. Test equipment .....	9
3.7. Power Line Conducted Emission Measurement Results .....	9
<b>4. FCC PART 15.247 REQUIREMENTS FOR DSSS &amp; OFDM MODULATION.....</b>	<b>12</b>
4.1. Test Setup .....	12
4.2. 6dB Bandwidth .....	12
4.3. Maximum Peak output power test .....	20
4.4. Band Edges Measurement .....	28
4.5. Peak Power Spectral Density .....	33
4.6. Radiated Emissions.....	41
<b>5. PHOTOGRAPH.....</b>	<b>52</b>
5.1. Photo of Conducted Emission Measurement.....	52
5.2. Photo of Radiation Emission Test .....	52

Appendix I (2 Pages)

Appendix II (4 Pages)

## TEST REPORT

Applicant : Shenzhen Samoon Technology Co., Ltd.  
Manufacturer : Shenzhen Samoon Technology Co., Ltd.  
EUT : SPORT DVR  
Model No. : SHA58S, SHA58  
Serial No. : N/A  
Trade Mark : N/A  
Rating : DC 5V, 1A, 5W Via AC/DC Adapter (AC 100- 240V, 50/60Hz, 0.3A)

Measurement Procedure Used:  
FCC Part15 Subpart C, Paragraph 15.247: 2012

The device described above is tested by Shenzhen Anbotek Compliance Laboratory Limited to determine the maximum emission levels emanating from the device and the severe levels of the device can endure and its performance criterion. The measurement results are contained in this test report and Shenzhen Anbotek Compliance Laboratory Limited is assumed full of responsibility for the accuracy and completeness of these measurements. Also, this report shows that the EUT (Equipment Under Test) is technically compliant with the FCC Part 15 Subpart C requirements.

This report applies to above tested sample only and shall not be reproduced in part without written approval of Shenzhen Anbotek Compliance Laboratory Limited.

Date of Test : Sep. 24~ Oct. 16, 2013

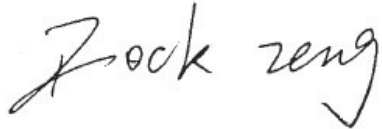
Prepared by :   
(Engineer / Rock Zeng)

Reviewer :   
(Project Manager / Sally Zhang)

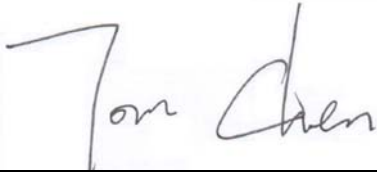
Approved & Authorized Signer :   
(Manager / Tom Chen)

## 1. GENERAL INFORMATION

### 1.1. Description of Device (EUT)

EUT	: SPORT DVR
Model Number	: SHA58S, SHA58 (Note: All samples are the same except the model number & shape of appliances, so we prepare "SHA58" for EMC test only.)
Test Power Supply	: AC 120V/60Hz for adapter
Adapter	: Power Supply Model: LCP-05001000A Input: AC 100-240V, 50/60Hz, 0.5A Output: DC 5V, 1000mA
RF Transmission Frequency	: 2412MHz~2462MHz (802.11b/802.11g/802.11n(HT20)) 2422MHz~2452MHz ( 802.11n(HT40))
Channels	: 11 For (802.11b/802.11g/802.11n(HT20)) 7 For (802.11n(HT40))
Modulation	: 802.11b CCK 802.11g OFDM 802.11n MCS
Antenna Type	: Integral
Antenna Gain	: 0 dBi
Applicant Address	: Shenzhen Samoon Technology Co., Ltd. Floor 6, Zhongyuntai Industrial Park, Yingrenshi Road Crossing, Shiyan Town, Baoan District, Shenzhen, CN
Manufacturer Address	: Shenzhen Samoon Technology Co., Ltd. Floor 6, Zhongyuntai Industrial Park, Yingrenshi Road Crossing, Shiyan Town, Baoan District, Shenzhen, CN
Date of receiver	: Sep. 24, 2013
Date of Test	: Sep. 24~ Oct. 16, 2013

## 1.2. Description of Test Facility

The test facility is recognized, certified, or accredited by the following organizations:

### **CNAS - LAB Code: L3503**

Shenzhen Anbotek Compliance Laboratory Limited., Laboratory has been assessed and in compliance with CNAS/CL01: 2006 accreditation criteria for testing laboratories (identical to ISO/IEC 17025:2005 General Requirements) for the Competence of Testing Laboratories.

### **FCC-Registration No.: 752021**

Shenzhen Anbotek Compliance Laboratory Limited, EMC Laboratory has been registered and fully described in a report filed with the (FCC) Federal Communications Commission. The acceptance letter from the FCC is maintained in our files. Registration 752021, July 10, 2013.

### **IC-Registration No.: 8058A-1**

Shenzhen Anbotek Compliance Laboratory Limited., EMC Laboratory has been registered and fully described in a report filed with the (IC) Industry Canada. The acceptance letter from the IC is maintained in our files. Registration 8058A, February 22, 2013.

### **Test Location**

All Emissions tests were performed at Shenzhen Anbotek Compliance Laboratory Limited. at 1/F., Building 1, SEC Industrial Park, No.0409 Qianhai Road, Nanshan District, Shenzhen, Guangdong, China

## 1.3. Measurement Uncertainty

Radiation Uncertainty :  $U_r = 4.3\text{dB}$

Conduction Uncertainty :  $U_c = 3.4\text{dB}$

## 2. TEST METHODOLOGY

The tests documented in this report were performed in accordance with ANSI C63.4: 2009 and FCC Part 15, Paragraph 15.247.

### 2.1. Summary of Test Results

The EUT has been tested according to the following specifications:

Standard	Test Type	Result	Notes
FCC Part 15, Paragraph 15.107, 15.207	Conducted Emission Test	PASS	Complies
FCC Part 15, Paragraph 15.247(b)(1)	Peak Output Power	PASS	Complies
FCC Part 15, Paragraph 15.247(a)(2)	6dB Bandwidth	PASS	Complies
FCC Part 15, Paragraph 15.247(c)	100kHz Bandwidth of Frequency Band Edges	PASS	Complies
FCC Part 15, Paragraph 15.209(a)(f)	Spurious Emission	PASS	Complies
FCC Part 15, Paragraph 15.247(a)(1)	Frequency Separation	-	N/A
FCC Part 15, Paragraph 15.247(a)(1)(iii)	Number of Hopping Frequency	-	N/A
FCC Part 15, Paragraph 15.247(a)(1)(iii)	Time of Occupancy	-	N/A
FCC Part 15, Paragraph 15.247(c)	Peak Power Density	PASS	Complies

### 2.2. Description of Test Modes

The EUT has been tested under operating condition.

Software used to control the EUT for staying in continuous transmitting and receiving mode is programmed.

IEEE802.11b: Channel 1(2412MHz), Channel 6(2437MHz) and Channel 11(2462MHz) with 1 Mbps lowest data rate (worst case) are chosen for the final testing.

IEEE802.11g: Channel 1(2412MHz), Channel 6(2437MHz) and Channel 11(2462MHz) with 6 Mbps lowest data rate (the worst case) are chosen for the final testing.

IEEE802.11n (HT20): Channel 1(2412MHz), Channel 6(2437MHz) and Channel 11(2462MHz) with 6.5 Mbps lowest data rate (the worst case) are chosen for the final testing.

IEEE802.11n (HT40): Channel 3(2422MHz), Channel 6(2437MHz) and Channel 9(2452MHz) with 13.5 Mbps lowest data rate (the worst case) are chosen for the final testing.

## 2.3. List of channels:

√ - available

X - tested

Number	Frequency(MHz)		802.11 b/g/n (HT20)	802.11 b/g/n (HT40)
1	2412	√	X	
2	2417	√		
3	2422	√		X
4	2427	√		
5	2432	√		
6	2437	√	X	X
7	2442	√		
8	2447	√		
9	2452	√		X
10	2457	√		
11	2462	√	X	

### 3. Conducted Emission Test

#### 3.1. Block Diagram of Test Setup

##### 3.1.1. Block diagram of connection between the EUT and simulators

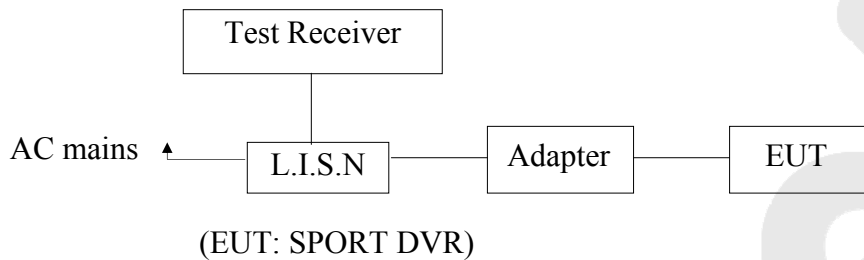

#### 3.2. Power Line Conducted Emission Measurement Limits (15.207)

Frequency MHz	Limits dB(μV)	
	Quasi-peak Level	Average Level
0.15 ~ 0.50	66 ~ 56*	56 ~ 46*
0.50 ~ 5.00	56	46
5.00 ~ 30.00	60	50

- Notes: 1. \*Decreasing linearly with logarithm of frequency.  
2. The lower limit shall apply at the transition frequencies.

#### 3.3. Configuration of EUT on Measurement

The following equipments are installed on Power Line Conducted Emission Measurement to meet the commission requirement and operating regulations in a manner which tends to maximize its emission characteristics in a normal application.

EUT : SPORT DVR  
Model Number : SHA58  
Applicant : Shenzhen Samoon Technology Co., Ltd.

#### 3.4. Operating Condition of EUT

3.4.1. Setup the EUT and simulator as shown as Section 3.1.

3.4.2. Turn on the power of all equipment.

3.4.3. Let the EUT work in test mode (ON) and measure it.



### 3.5. Test Procedure

The EUT system is connected to the power mains through a line impedance stabilization network (L.I.S.N.). This provides a 50ohm coupling impedance for the EUT system. Please refer the block diagram of the test setup and photographs. Both sides of AC line are checked to find out the maximum conducted emission. In order to find the maximum emission levels, the relative positions of equipment and all of the interface cables shall be changed according to FCC ANSI C63.4-2003 on Conducted Emission Measurement.

The bandwidth of test receiver (ESCI) set at 9KHz.

The frequency range from 150KHz to 30MHz is checked.

The test results are reported on Section 3.6.

### 3.6. Test equipment

Item	Equipment	Manufacturer	Model No.	Serial No.	Last Cal.	Cal. Interval
1.	Two-Line V-network	Rohde & Schwarz	ENV216	100055	Apr. 23, 2013	1 Year
2.	EMI Test Receiver	Rohde & Schwarz	ESCI	100627	Apr. 23, 2013	1 Year
3.	RF Switching Unit	Compliance Direction	RSU-M2	38303	Apr. 23, 2013	1 Year

### 3.7. Power Line Conducted Emission Measurement Results

**PASS.**

The frequency range from 150KHz to 30 MHz is investigated.

Please refer the following pages.

**CONDUCTED EMISSION TEST DATA**

EUT: SPORT DVR M/N: SHA58  
 Operating Condition: ON  
 Test Site: 1# Shielded Room  
 Operator: Rock Zeng  
 Test Specification: AC 120V/60Hz for Adapter  
 Comment: Live Line  
 Tem:25°C Hum:50%

**SCAN TABLE: "Voltage (150K~30M) FIN"**

Short Description: 150K-30M Disturbance Voltages

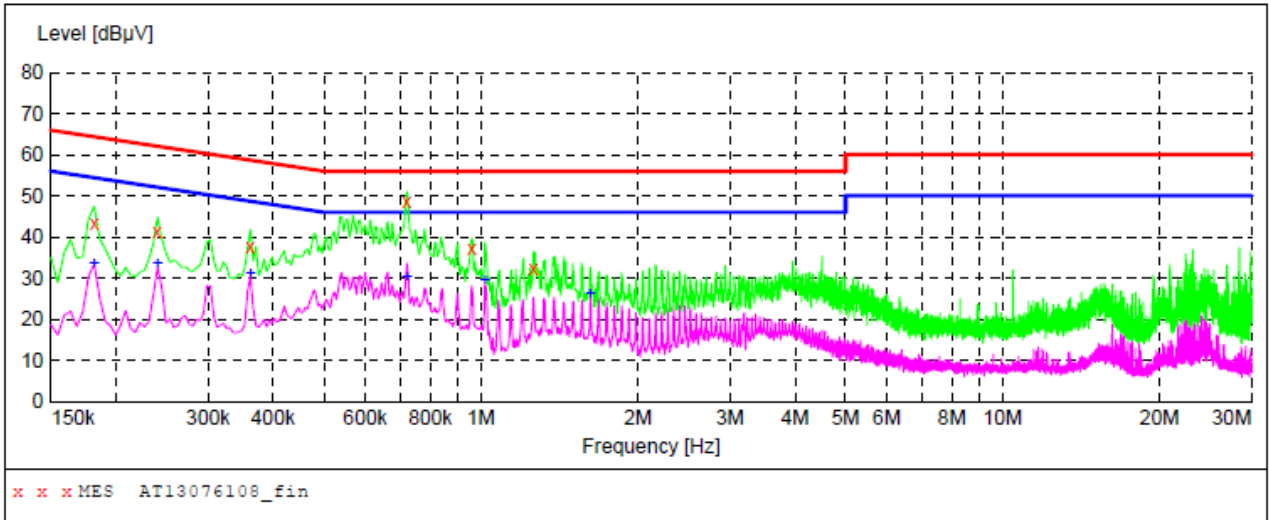

**MEASUREMENT RESULT: "AT1307660108\_fin"**

9/25/2013 4:02PM

Frequency MHz	Level dBµV	Transd dB	Limit dBµV	Margin dB	Detector	Line	PE
0.181500	43.50	20.1	64	20.9	QP	L1	GND
0.240000	41.20	20.1	62	20.9	QP	L1	GND
0.361500	37.60	20.1	59	21.1	QP	L1	GND
0.721500	48.80	20.1	56	7.2	QP	L1	GND
0.960000	37.10	20.2	56	18.9	QP	L1	GND
1.261000	32.50	20.2	56	23.5	QP	L1	GND

**MEASUREMENT RESULT: "AT1307660108\_fin2"**

9/25/2013 4:02PM

Frequency MHz	Level dBµV	Transd dB	Limit dBµV	Margin dB	Detector	Line	PE
0.181500	33.60	20.1	54	20.8	AV	L1	GND
0.240000	33.60	20.1	52	18.5	AV	L1	GND
0.361500	31.30	20.1	49	17.4	AV	L1	GND
0.721500	30.20	20.1	46	15.8	AV	L1	GND
1.018000	29.40	20.2	46	16.6	AV	L1	GND
1.621000	26.30	20.3	46	19.7	AV	L1	GND

**CONDUCTED EMISSION TEST DATA**

EUT: SPORT DVR M/N: SHA58  
 Operating Condition: ON  
 Test Site: 1# Shielded Room  
 Operator: Rock Zeng  
 Test Specification: AC 120V/60Hz for Adapter  
 Comment: Neutral Line  
 Tem:25°C Hum:50%

**SCAN TABLE: "Voltage (150K~30M) FIN"**

Short Description: 150K-30M Disturbance Voltages

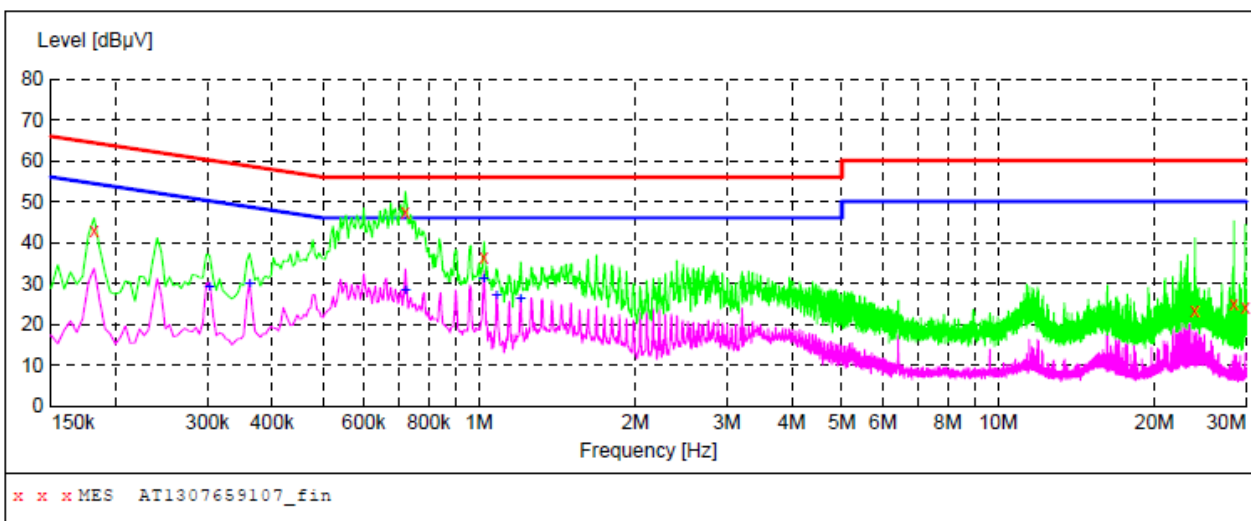

**MEASUREMENT RESULT: "AT1307660107\_fin"**

9/25/2013 3:59PM

Frequency MHz	Level dBµV	Transd dB	Limit dBµV	Margin dB	Detector	Line	PE
0.181500	43.00	20.1	64	21.4	QP	N	GND
0.721500	47.30	20.1	56	8.7	QP	N	GND
1.022500	36.30	20.2	56	19.7	QP	N	GND
23.914000	23.20	20.8	60	36.8	QP	N	GND
28.414000	24.90	20.9	60	35.1	QP	N	GND
29.912500	24.30	20.9	60	35.7	QP	N	GND

**MEASUREMENT RESULT: "AT1307660107\_fin2"**

9/25/2013 3:59PM

Frequency MHz	Level dBµV	Transd dB	Limit dBµV	Margin dB	Detector	Line	PE
0.303000	29.20	20.1	50	21.0	AV	N	GND
0.361500	30.00	20.1	49	18.7	AV	N	GND
0.721500	28.30	20.1	46	17.7	AV	N	GND
1.022500	31.30	20.2	46	14.7	AV	N	GND
1.081000	27.00	20.2	46	19.0	AV	N	GND
1.202500	26.30	20.2	46	19.7	AV	N	GND

## 4. FCC Part 15.247 Requirements for DSSS & OFDM Modulation

### 4.1. Test Setup

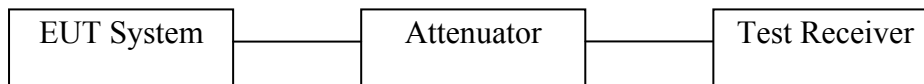

### 4.2. 6dB Bandwidth

#### a. Limit

For the direct sequence systems, the minimum 6dB bandwidth shall be at least 500kHz.

#### b. Test Procedure

1. Place the EUT on the table and set it in the transmitting mode.
2. Remove the antenna from the EUT and then connect a low loss RF cable from the antenna port to the spectrum analyzer.
3. Set the spectrum analyzer as:  
 RBW = 100kHz, VBW  $\geq$  3\*RBW = 300kHz,  
 Detector= Peak  
 Trace mode= Max hold.  
 Sweep- auto couple.
4. Mark the peak frequency and -6dB (upper and lower) frequency.
5. Repeat until all the rest channels are investigated.

#### c. Test Setup See 4.1

#### d. Test Equipment

Item	Equipment	Manufacturer	Model No.	Serial No.	Last Cal.	Cal. Interval
1.	Spectrum Analysis	Agilent	E4407B	US39390582	Aug. 09, 2013	1 Year
2.	Preamplifier	Instruments corporation	EMC011830	980100	Aug. 09, 2013	1 Year
3.	EMI Test Receiver	Rohde & Schwarz	ESPI	101604	Apr. 23, 2013	1 Year
4.	Double Ridged Horn Antenna	Instruments corporation	GTH-0118	351600	Aug. 09, 2013	3 Year
5.	Bilog Broadband Antenna	Schwarzbeck	VULB9163	VULB 9163-289	Apr. 23, 2013	3 Year
6.	Pre-amplifier	SONOMA	310N	186860	Apr. 23, 2013	1 Year
7.	EMI Test Software EZ-EMC	SHURPLE	N/A	N/A	N/A	N/A

#### e. Test Results

Pass.

**f. Test Data**

Test mode: IEEE 802.11b

Channel	Frequency (MHz)	Bandwidth (MHz)	Limit (kHz)	Results
Low	2412	10.10		Pass
Mid	2437	10.0	>500	Pass
High	2462	10.0		Pass

Test mode: IEEE 802.11g

Channel	Frequency (MHz)	Bandwidth (MHz)	Limit (kHz)	Results
Low	2412	16.60		Pass
Mid	2437	16.60	>500	Pass
High	2462	16.60		Pass

Test mode: IEEE 802.11n (HT20)

Channel	Frequency (MHz)	Bandwidth (MHz)	Limit (kHz)	Results
Low	2412	17.80		Pass
Mid	2437	17.80	>500	Pass
High	2462	17.80		Pass

Test mode: IEEE 802.11n (HT40)

Channel	Frequency (MHz)	Bandwidth (MHz)	Limit (kHz)	Results
Low	2422	35.80		Pass
Mid	2437	35.80	>500	Pass
High	2452	35.80		Pass

Test Plots See the following page.

Test Mode: 802.11b---Low

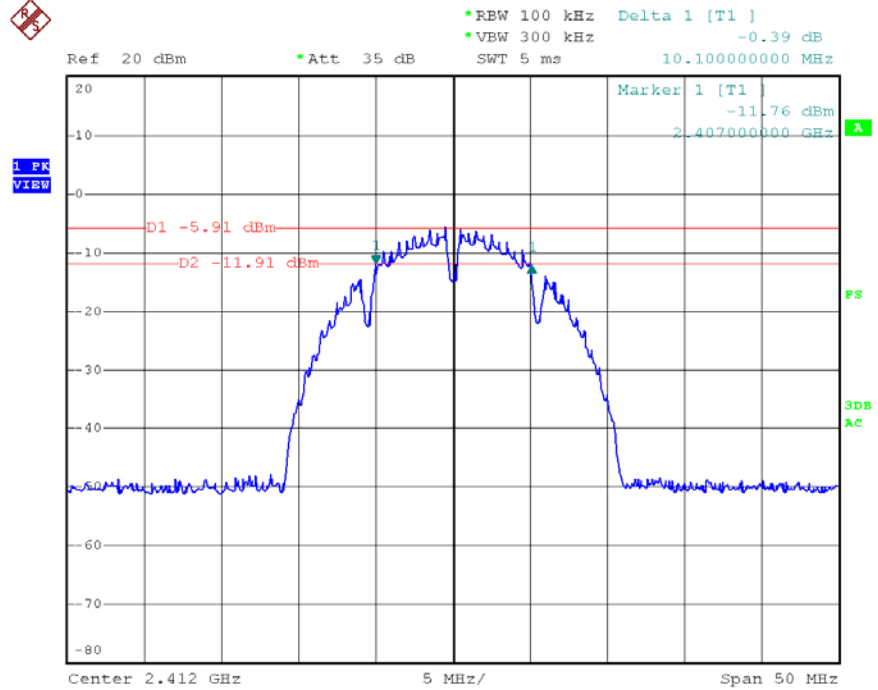

Date: 11.OCT.2013 11:28:03

Test Mode: 802.11b---Mid

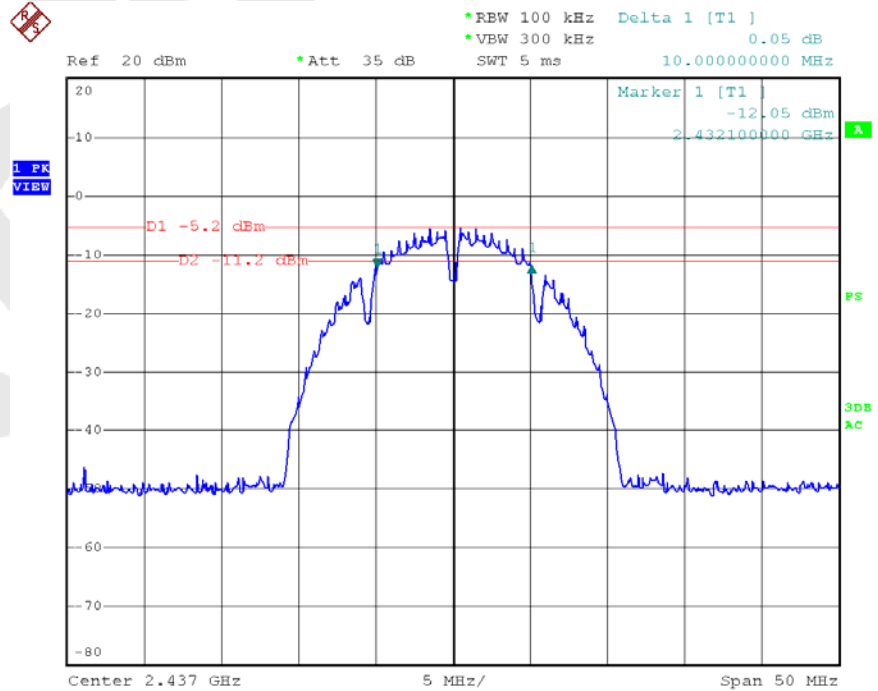

Date: 11.OCT.2013 11:33:18

Test Mode: 802.11b---High

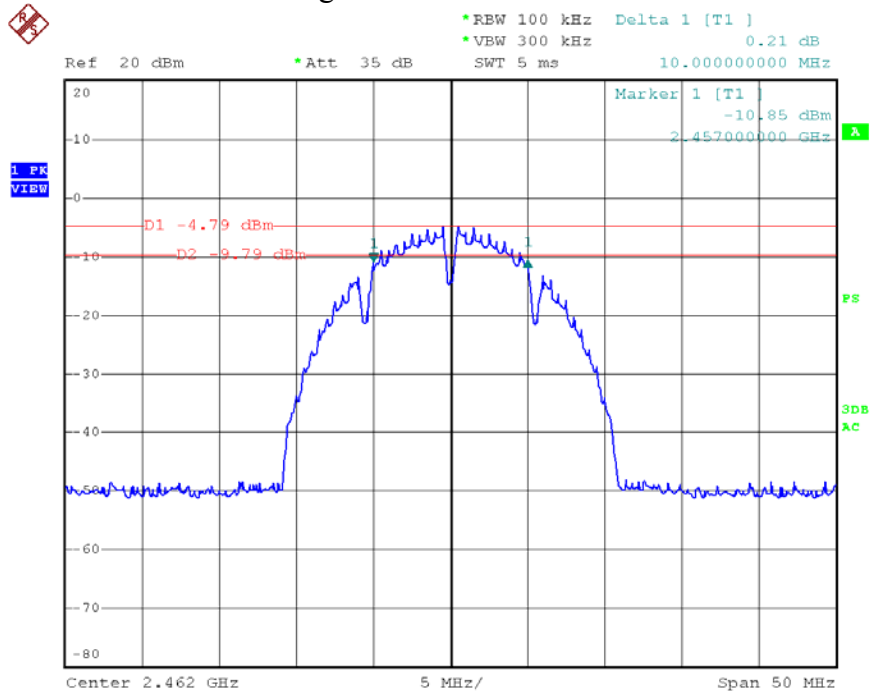

Date: 11.OCT.2013 11:35:41

Test Mode: 802.11g---Low

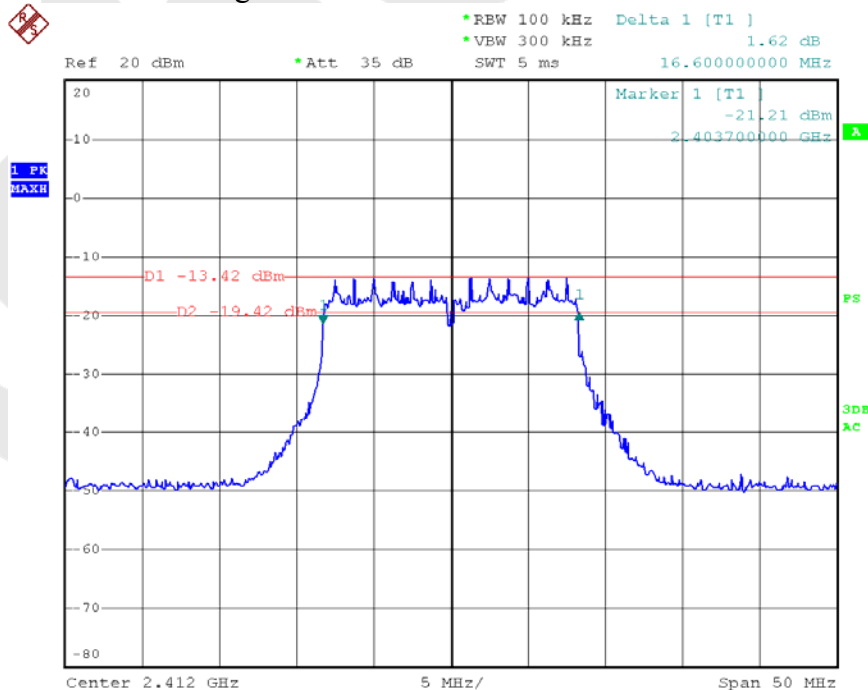

Date: 11.OCT.2013 11:38:58

Test Mode: 802.11g---Mid

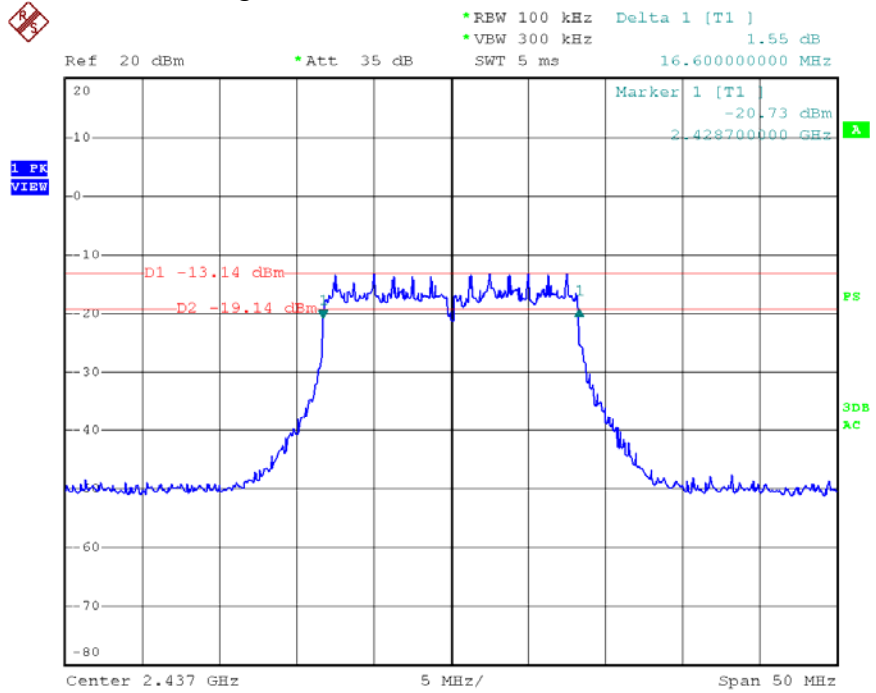

Date: 11.OCT.2013 11:44:00

Test Mode: 802.11g---High

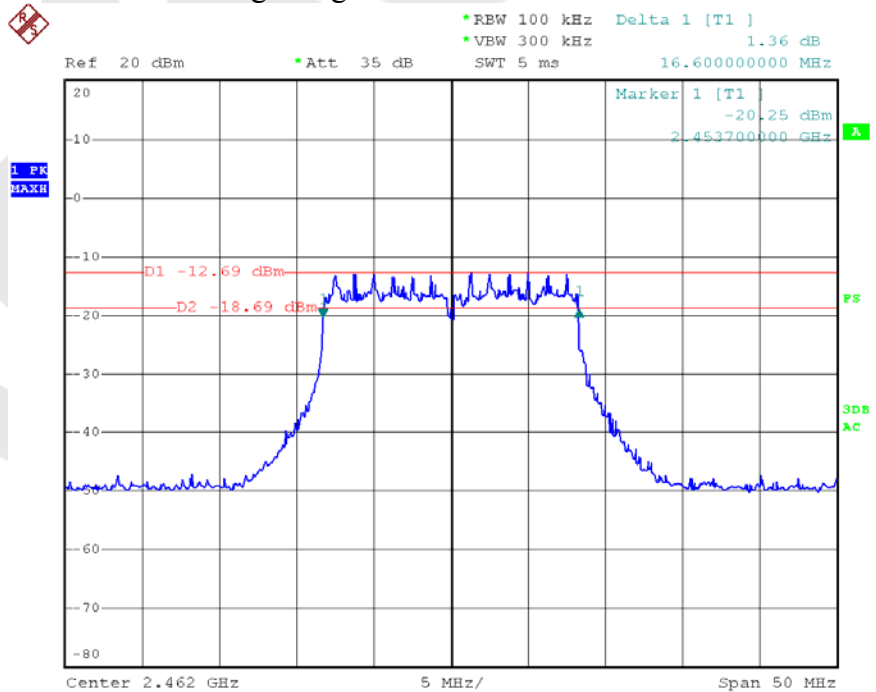

Date: 11.OCT.2013 11:42:32



Test Mode: 802.11n (HT20)---Low

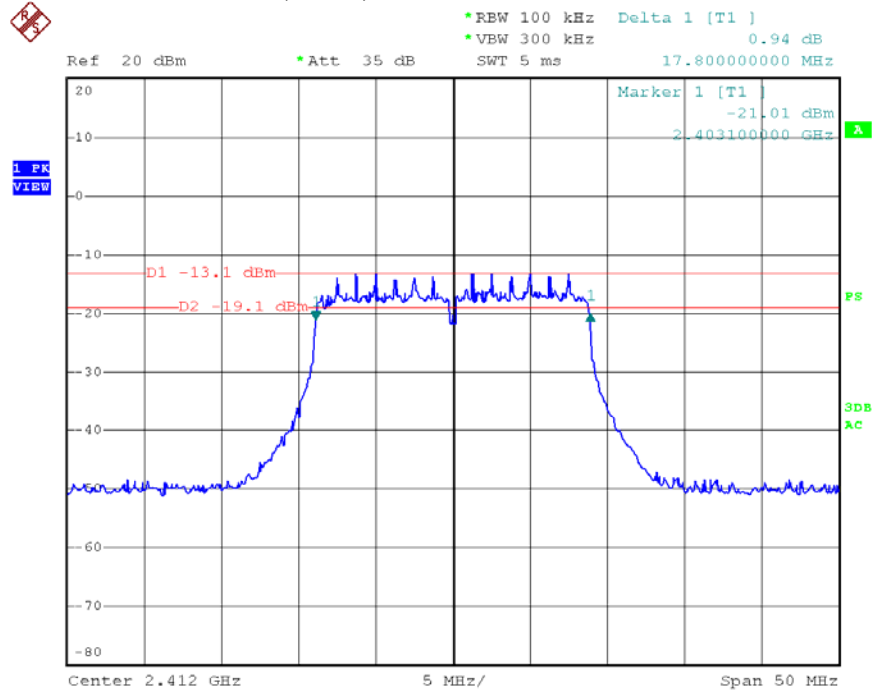

Date: 11.OCT.2013 14:25:26

Test Mode: 802.11n (HT20)---Mid

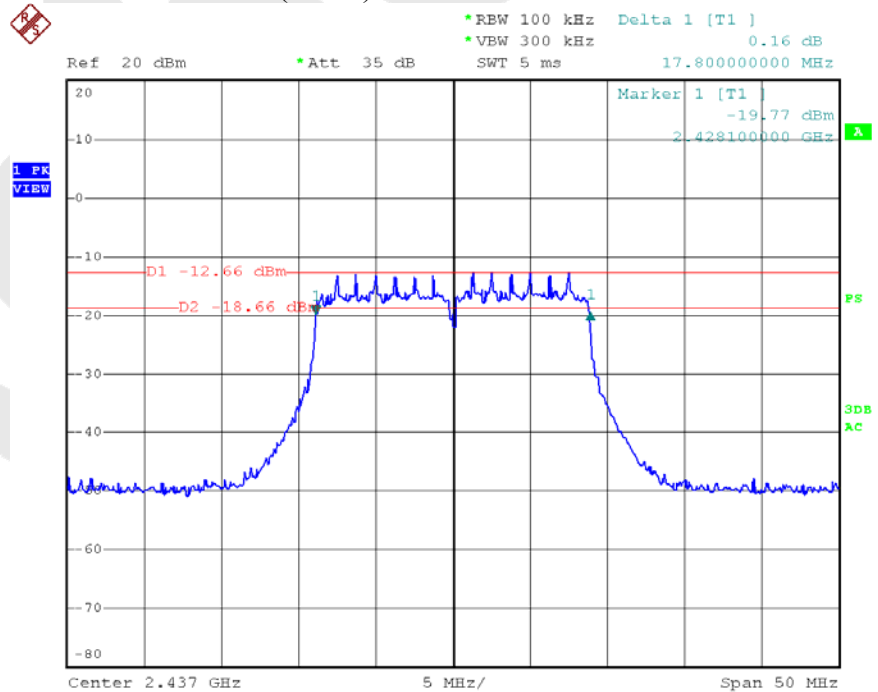

Date: 11.OCT.2013 14:27:10

Test Mode: 802.11n (HT20)---High

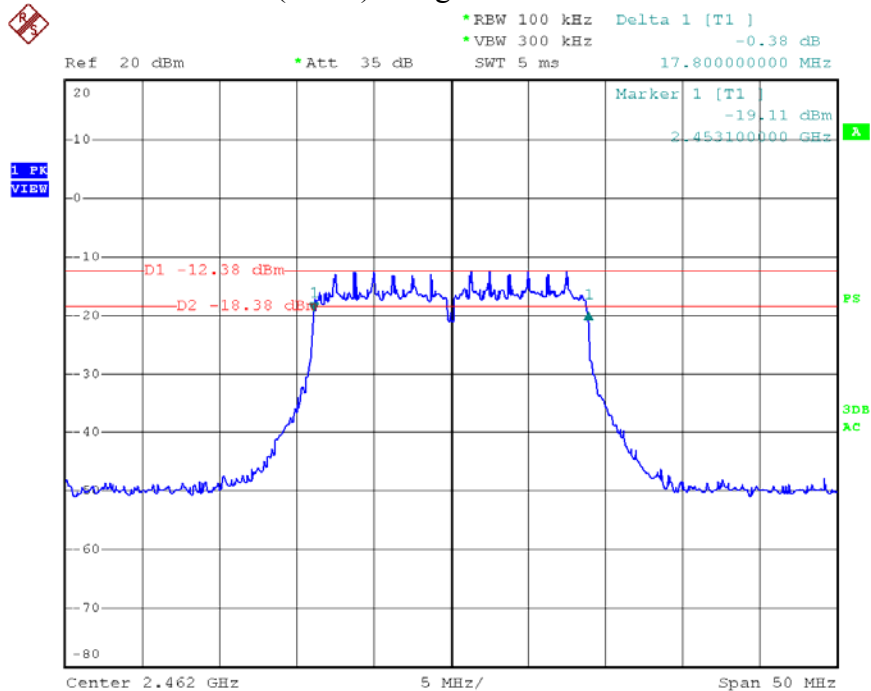

Date: 11.OCT.2013 14:28:47

Test Mode: 802.11n (HT40)---Low

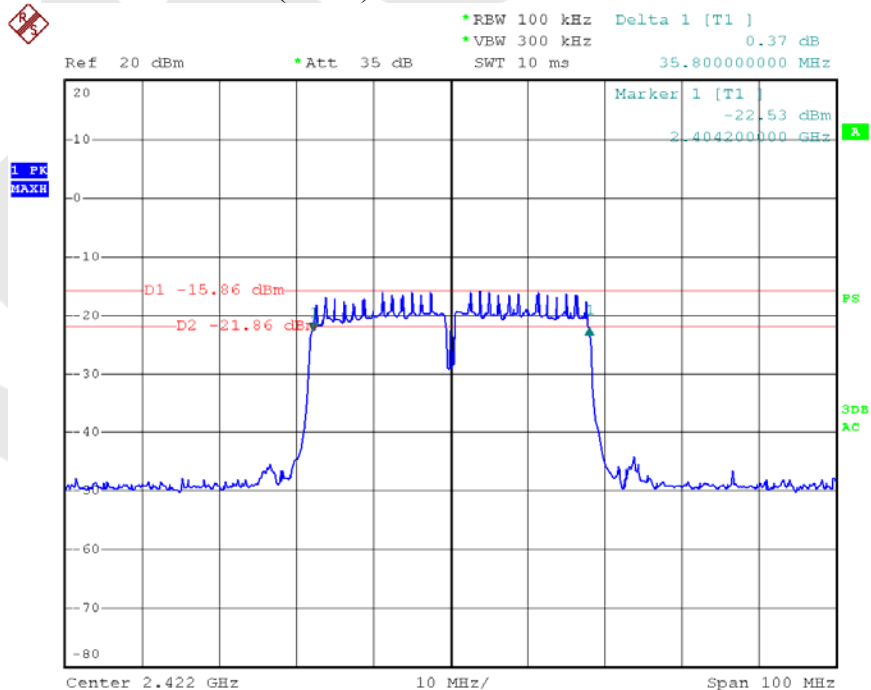

Date: 11.OCT.2013 14:30:59

Test Mode: 802.11n (HT40)---Mid

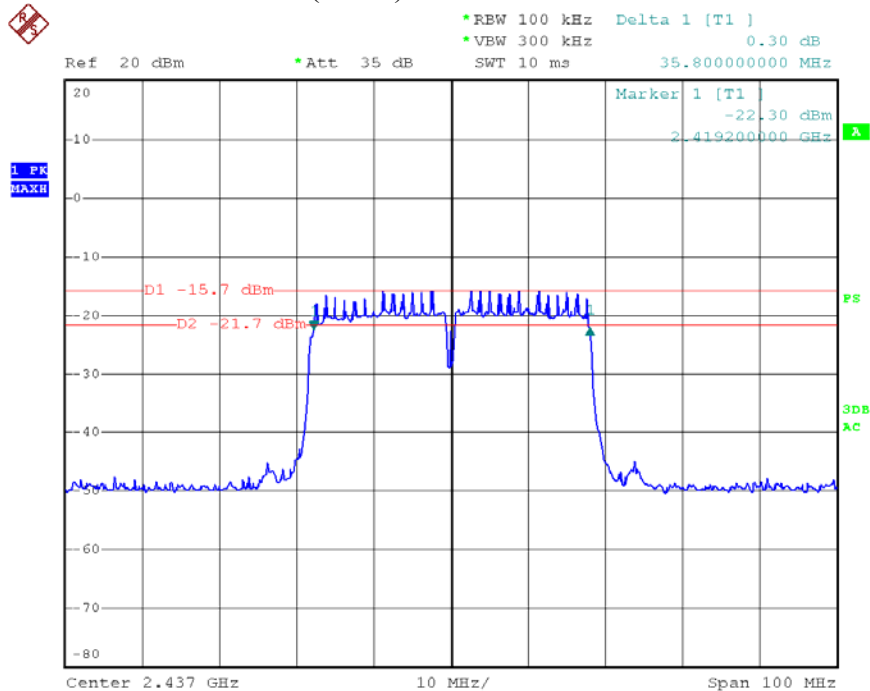

Date: 11.OCT.2013 14:32:29

Test Mode: 802.11n (HT40)---High

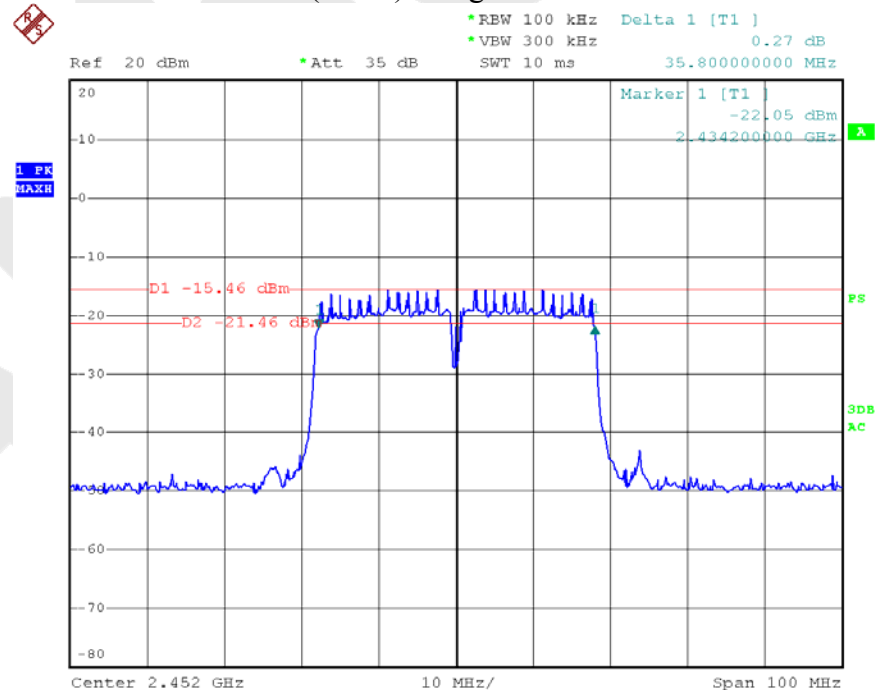

Date: 11.OCT.2013 14:34:05

### 4.3. Maximum Peak output power test

#### a. Limit

The maximum peak output power of the intentional radiator shall not exceed the following:

1. For systems using digital modulation in the bands of 902-928 MHz, 2400-2483.5 MHz, and 5725-5850 MHz: 1 watt (30dBm).
2. Except as shown in paragraphs (b)(3) (i), (ii) and (iii) of this section, if transmitting antenna of directional gain greater than 6 dBi are used the peak output power from the intentional radiator shall be reduced below the stated values in paragraphs (b)(1) or (b)(2) of this section, as appropriate, by the amount in dB that the directional gain of the antenna exceeds 6 dBi.

#### b. Configuration of Measurement

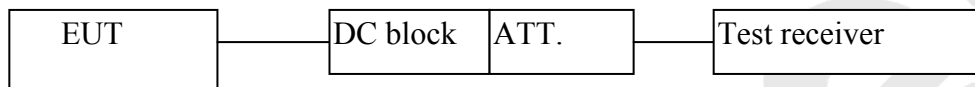

#### c. Data Rates

IEEE802.11b: Channel 1(2412MHz), Channel 6(2437MHz) and Channel 11(2462MHz) with 1 Mbps data rate (worst case) are chosen for the final testing.

IEEE802.11g: Channel 1(2412MHz), Channel 6(2437MHz) and Channel 11(2462MHz) with 6 Mbps data rate (the worst case) are chosen for the final testing.

IEEE802.11n (HT20: Channel 1(2412MHz), Channel 6(2437MHz) and Channel 11(2462MHz) with 6.5Mbps data rate (the worst case) are chosen for the final testing.

IEEE802.11n (HT40: Channel 3(2422MHz), Channel 6(2437MHz) and Channel 9(2452MHz) with 13.5Mbps data rate (the worst case) are chosen for the final testing.

#### d. Test Procedure

**This test was according the kDB 558074 9.1.2:**

1. This procedure may be used when the maximum available RBW of the measurement instrument is less than the DTS bandwidth.
2. Set the RBW = 1 MHz.
3. Set the VBW  $\geq 3 \times$  RBW = 3 MHz.
4. Set the span  $\geq 1.5 \times$  DTS bandwidth.
5. Detector = peak.
6. Sweep time = auto couple.
7. Trace mode = max hold.
8. Allow trace to fully stabilize.
9. Use the instrument's band/channel power measurement function with the band limits set equal to the DTS bandwidth edges (for some instruments, this may require a manual override to select peak detector). If the instrument does not have a band power function, sum the spectrum levels (in linear power units) at intervals equal to the RBW extending across the DTS bandwidth.

#### e. Test Equipment

Same as the equipment listed in 4.2.

#### f. Test Results

Pass.

**g. Test Data**

Test mode: IEEE 802.11b

Channel	Frequency (MHz)	Maximum transmit power (dBm)	Limit		Result
			(dBm)	(watts)	
Low	2412	6.81	30	1	Pass
Mid	2437	7.44			Pass
High	2462	7.63			Pass

Test mode: IEEE 802.11g

Channel	Frequency (MHz)	Maximum transmit power (dBm)	Limit		Result
			(dBm)	(watts)	
Low	2412	5.52	30	1	Pass
Mid	2437	6.05			Pass
High	2462	6.44			Pass

Test mode: IEEE 802.11n (HT20)

Channel	Frequency (MHz)	Maximum transmit power (dBm)	Limit		Result
			(dBm)	(watts)	
Low	2412	5.75	30	1	Pass
Mid	2437	6.32			Pass
High	2462	6.86			Pass

Test mode: IEEE 802.11n (HT40)

Channel	Frequency (MHz)	Maximum transmit power (dBm)	Limit		Result
			(dBm)	(watts)	
Low	2422	5.84	30	1	Pass
Mid	2437	6.07			Pass
High	2452	6.32			Pass

Test Mode: 802.11b ---Low



Ref 20 dBm \*Att 35 dB \*RBW 1 MHz Marker 1 [T1] -1.32 dBm  
\*VBW 3 MHz \*SWT 5 ms 2.412880000 GHz

1 PK  
MAXH

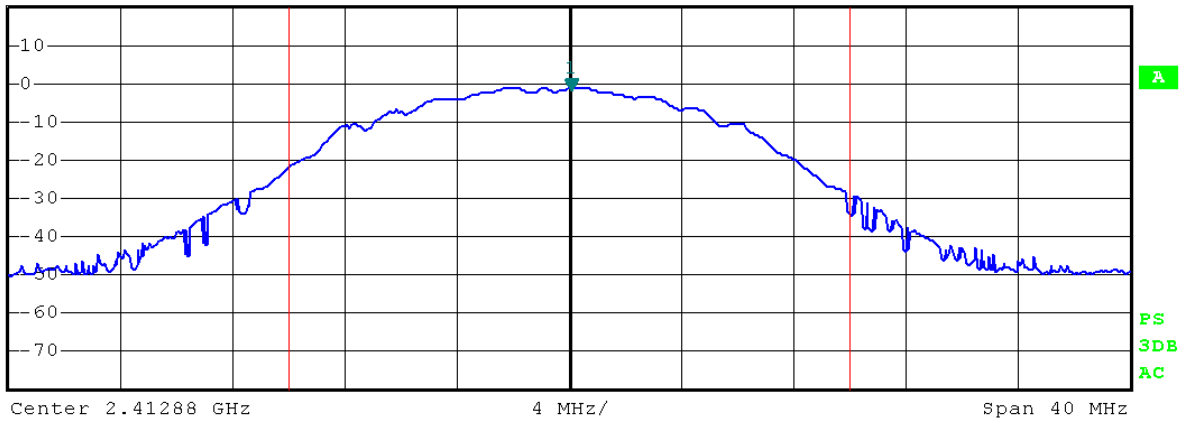

**Tx Channel**  
Bandwidth 20 MHz Power 6.81 dBm

Test Mode: 802.11b---Mid



Ref 20 dBm \*Att 35 dB \*RBW 1 MHz Marker 1 [T1] -0.57 dBm  
\*VBW 3 MHz \*SWT 5 ms 2.438080000 GHz

1 PK  
MAXH

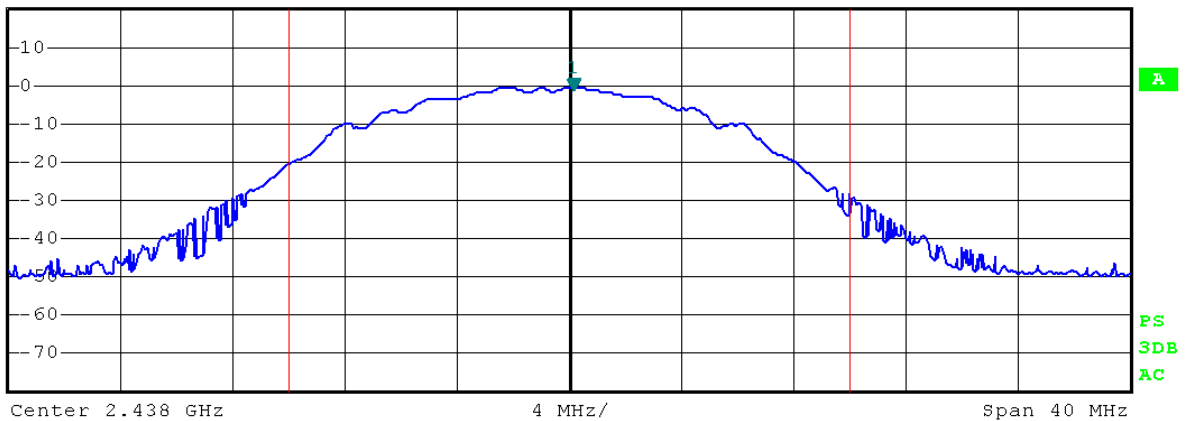

**Tx Channel**  
Bandwidth 20 MHz Power 7.44 dBm

Test Mode: 802.11b---High

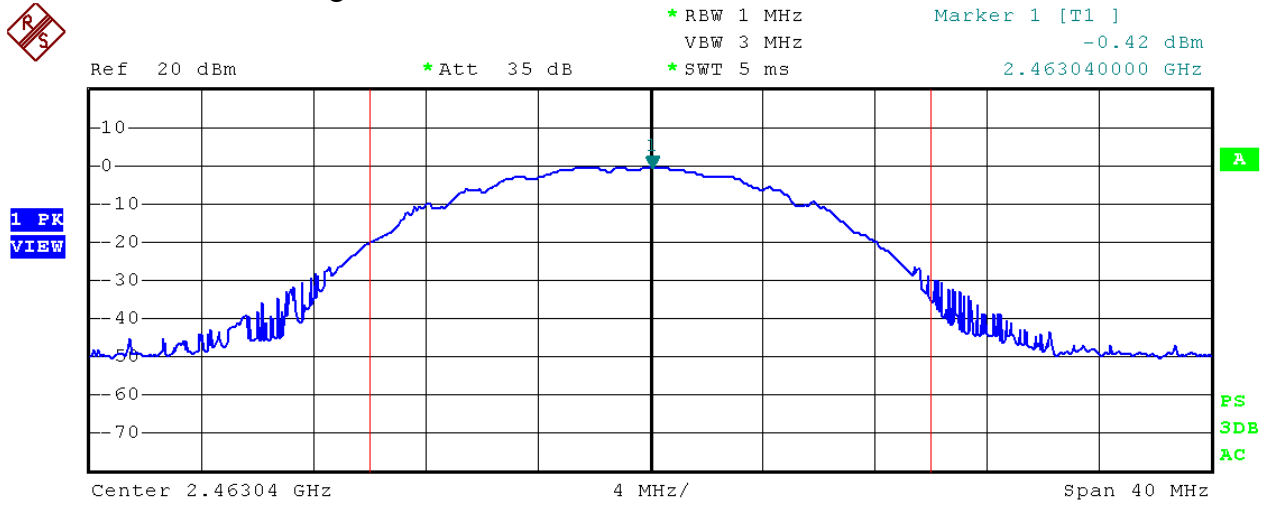

Test Mode: 802.11g ---Low

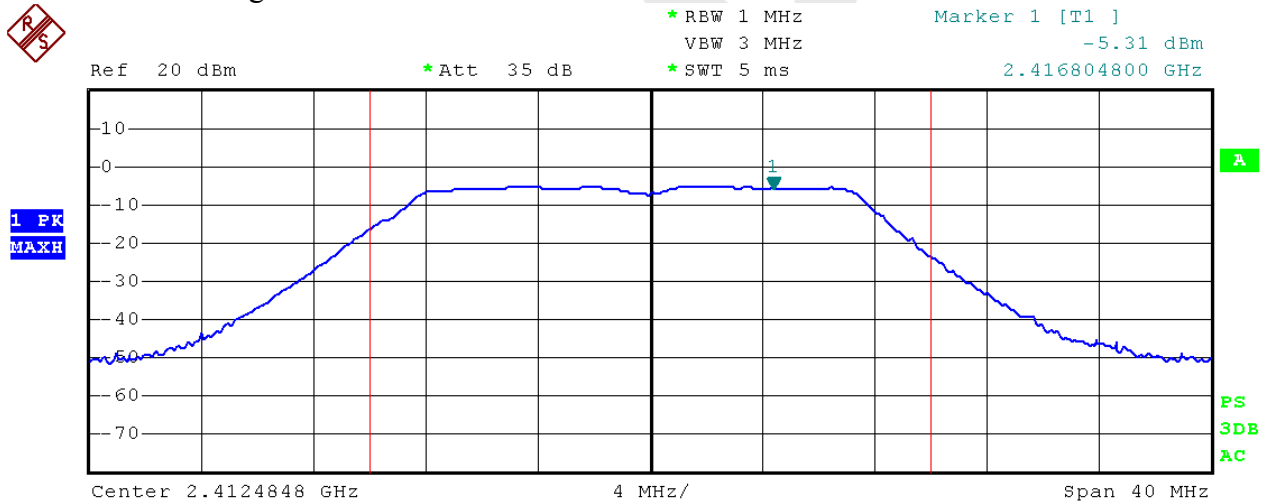

Test Mode: 802.11g---Mid



Ref 20 dBm \*Att 35 dB \*RBW 1 MHz Marker 1 [T1 ]  
 VBW 3 MHz -4.88 dBm  
 \*SWT 5 ms 2.439760000 GHz

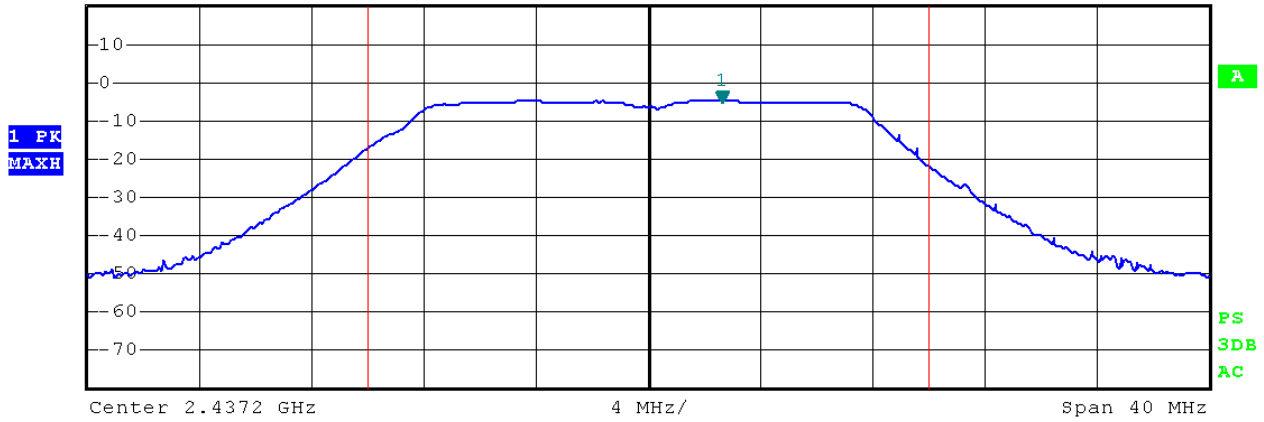

**Tx Channel**

Bandwidth 20 MHz Power 6.05 dBm

Test Mode: 802.11g---High



Ref 20 dBm \*Att 35 dB \*RBW 1 MHz Marker 1 [T1 ]  
 VBW 3 MHz -4.50 dBm  
 \*SWT 5 ms 2.464240000 GHz

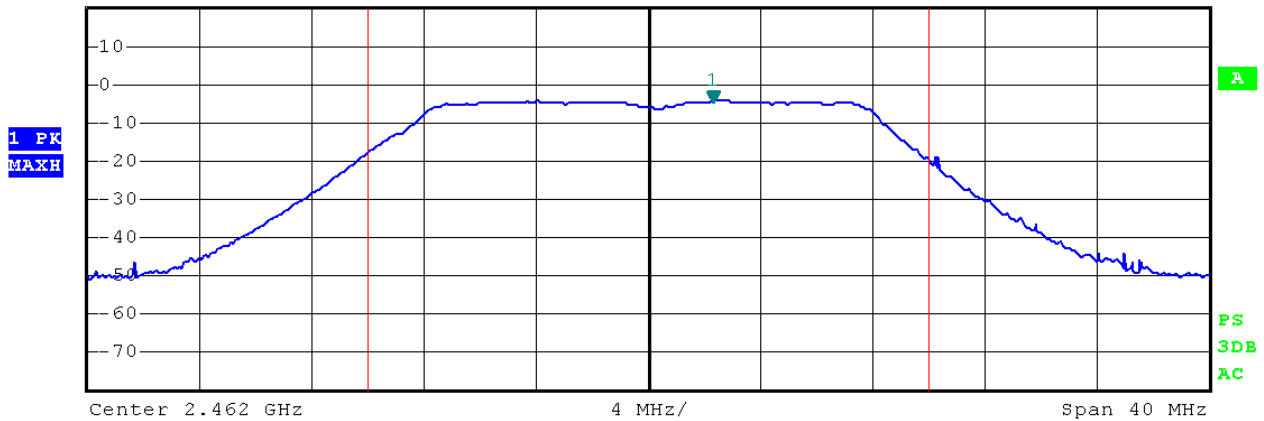

**Tx Channel**

Bandwidth 20 MHz Power 6.44 dBm



Test Mode: 802.11n (HT20) ---Low



\*RBW 1 MHz  
VBW 3 MHz  
\*SWT 5 ms  
Marker 1 [T1 ]  
-5.31 dBm  
2.409120000 GHz

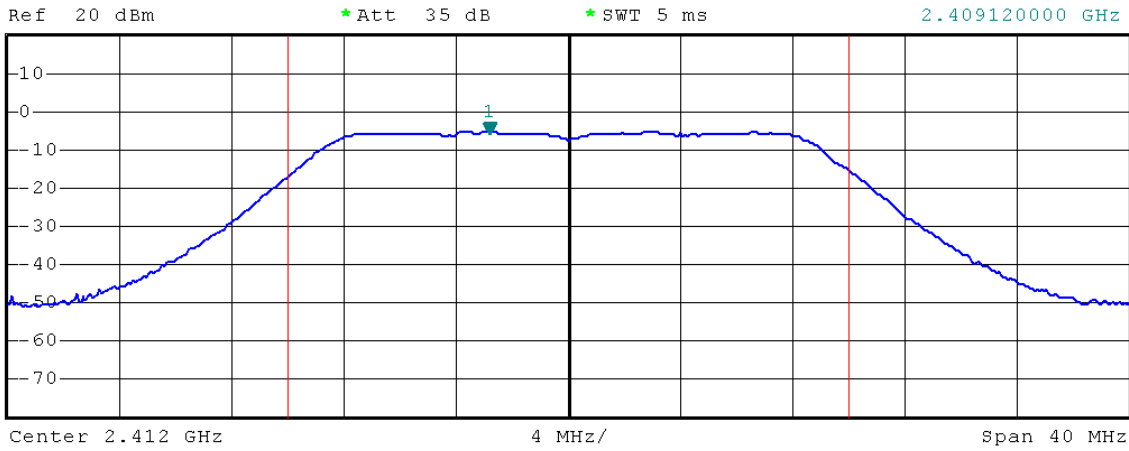

**Tx Channel**  
Bandwidth 20 MHz Power 5.75 dBm

Test Mode: 802.11n (HT20)---Mid



\*RBW 1 MHz  
VBW 3 MHz  
\*SWT 5 ms  
Marker 1 [T1 ]  
-4.77 dBm  
2.434120000 GHz

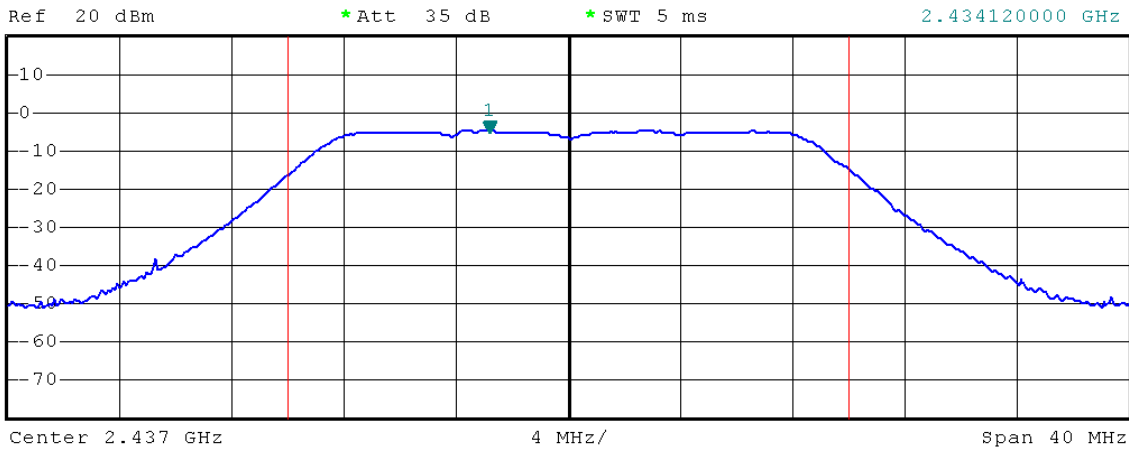

**Tx Channel**  
Bandwidth 20 MHz Power 6.32 dBm

Test Mode: 802.11n (HT20) ---High

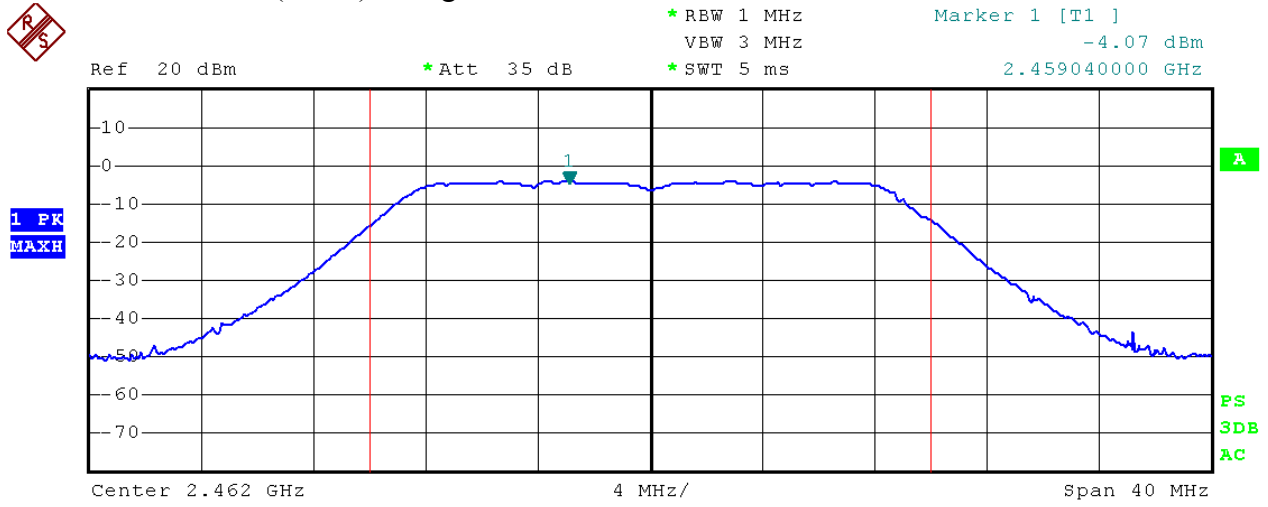

**Tx Channel**  
Bandwidth 20 MHz Power 6.86 dBm

Test Mode: 802.11n (HT40) ---Low

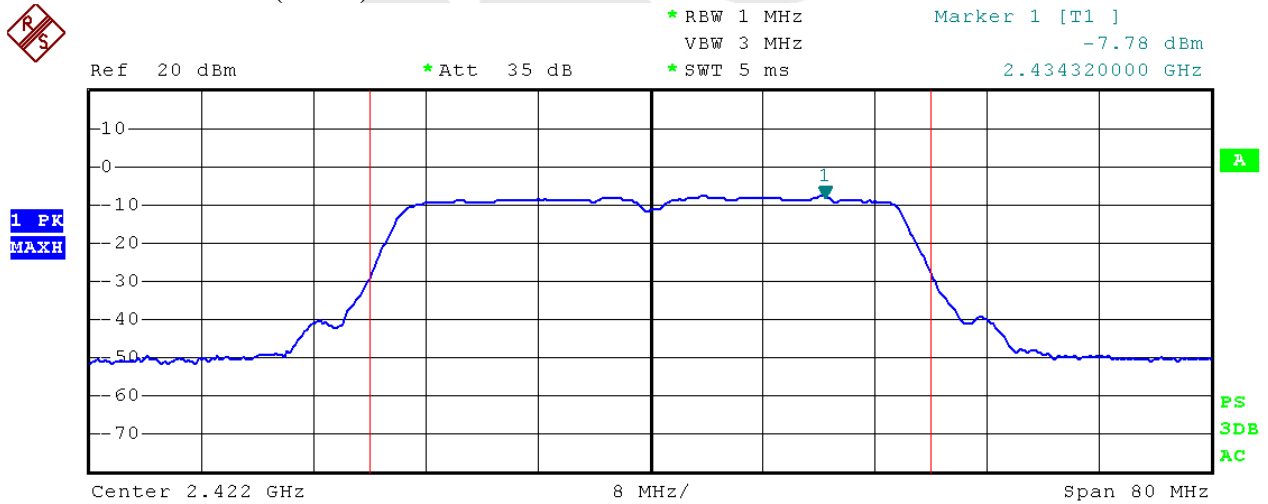

**Tx Channel**  
Bandwidth 40 MHz Power 5.84 dBm

Test Mode: 802.11n (HT40) --- Mid



\*RBW 1 MHz  
VBW 3 MHz  
\*SWT 5 ms  
Marker 1 [T1 ]  
-7.60 dBm  
2.440680000 GHz

Ref 20 dBm \*Att 35 dB

1 PK  
MAXH

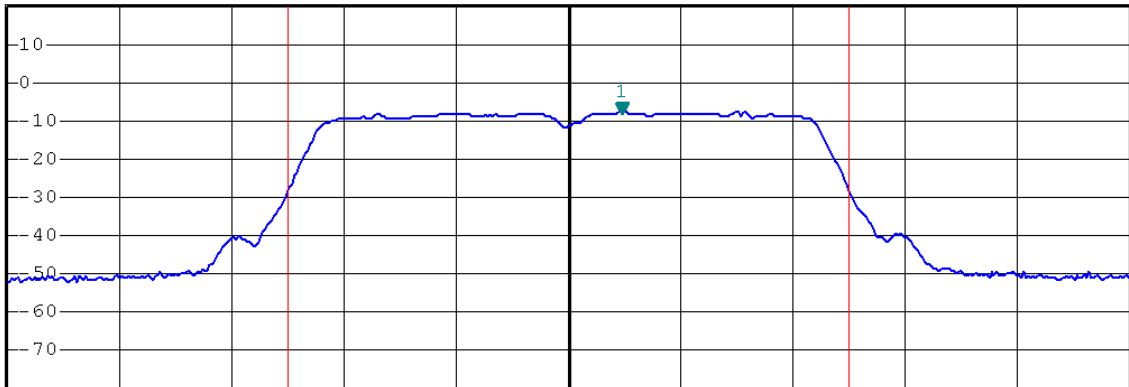

Center 2.437 GHz 8 MHz/ Span 80 MHz

**Tx Channel**

Bandwidth 40 MHz Power 6.07 dBm

Test Mode: 802.11n (HT40)---High



\*RBW 1 MHz  
VBW 3 MHz  
\*SWT 5 ms  
Marker 1 [T1 ]  
-7.32 dBm  
2.455840000 GHz

Ref 20 dBm \*Att 35 dB

1 PK  
MAXH

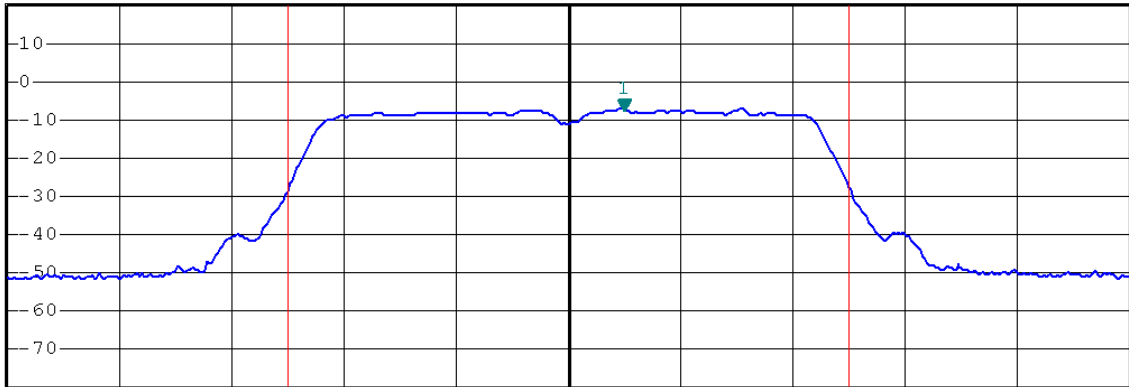

Center 2.452 GHz 8 MHz/ Span 80 MHz

**Tx Channel**

Bandwidth 40 MHz Power 6.32 dBm

#### 4.4. Band Edges Measurement

**a. Limit**

According to §15.247(c), in any 100 kHz bandwidth outside the frequency bands in which the spread spectrum intentional radiator is operating, the radio frequency power that is produced by the intentional radiator shall be at least 20dB below that in the 100kHz bandwidth within the band that contains the highest level of the desired power, In addition, radiated emissions which fall in the restricted bands, as defined in §15.205(a), must also comply with the radiated emission limits specified in §15.209(a).

**b. Test Procedure**

1. Set RBW=100KHz, VBW=300KHz
2. Detector=peak
3. Sweep time= auto
4. Trace mode=max hold.

**c. Test Equipment**

Same as the equipment listed in 4.2.

**d. Test Results**

Pass.

**e. Test Plots**

See the following page.

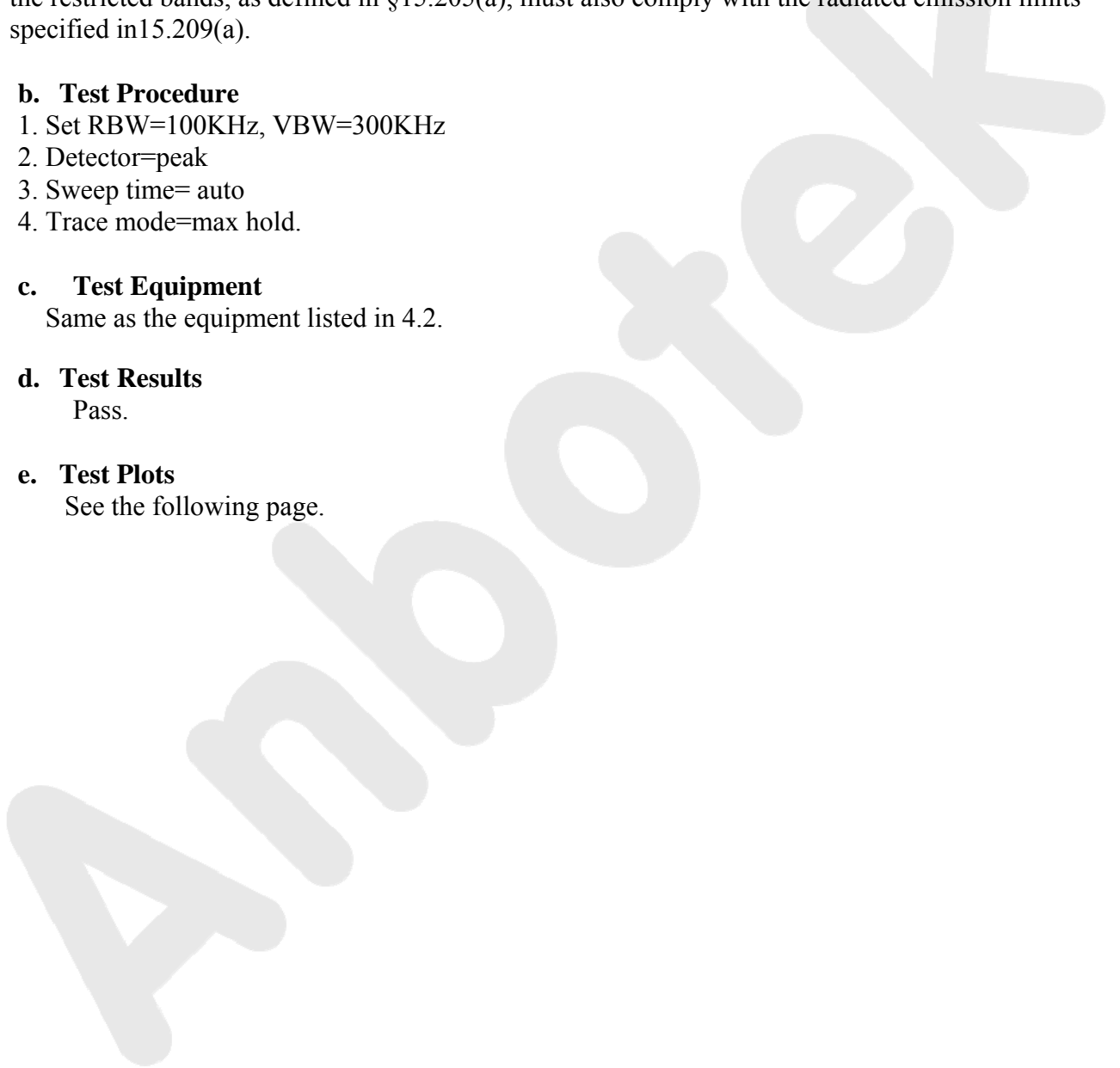

Test Mode: 802.11b ---Low

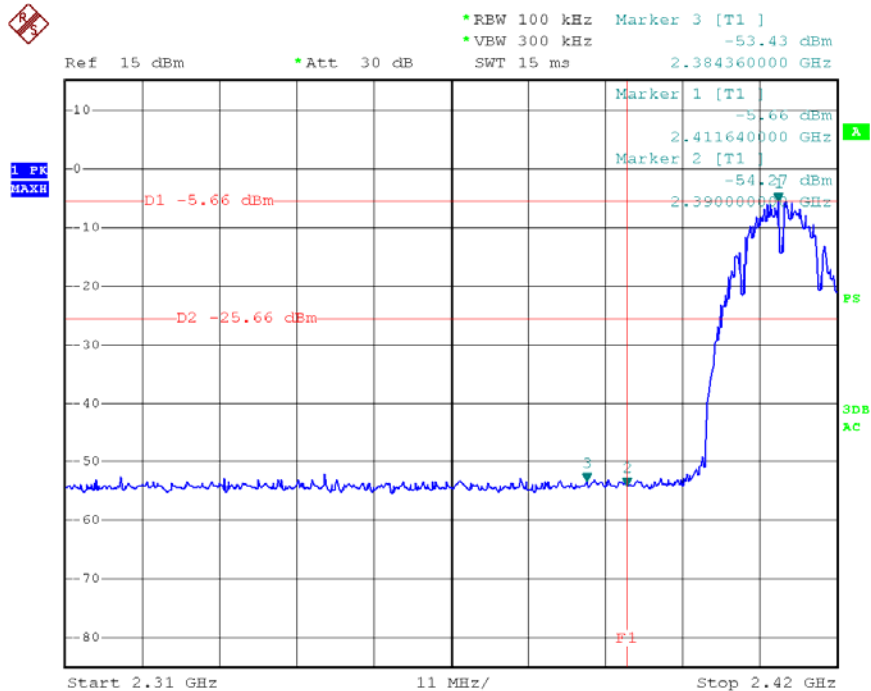

Date: 14.OCT.2013 16:40:39

Test Mode: 802.11b ---High

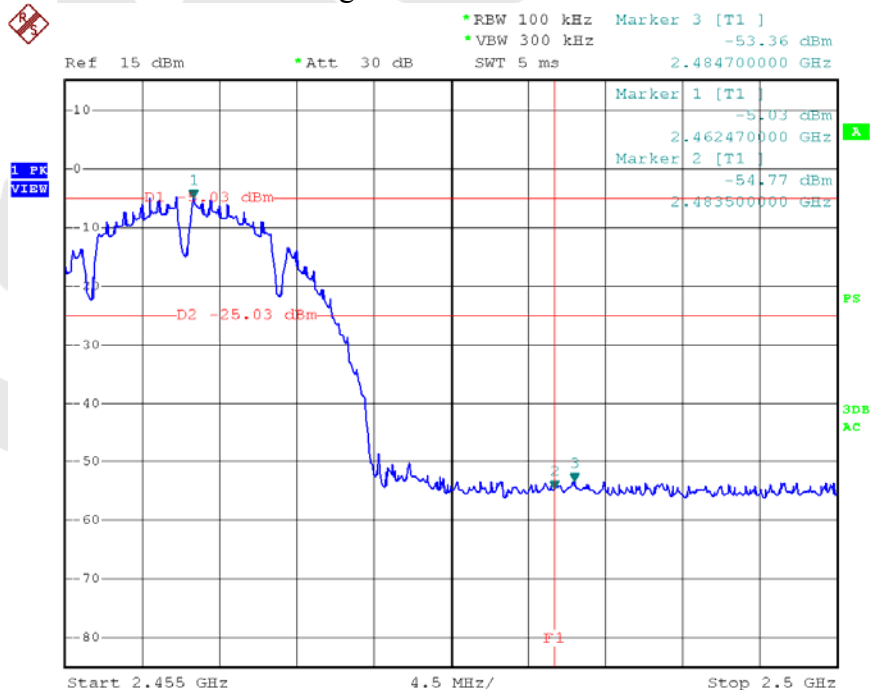

Date: 14.OCT.2013 16:42:49

Test Mode: 802.11g ---Low

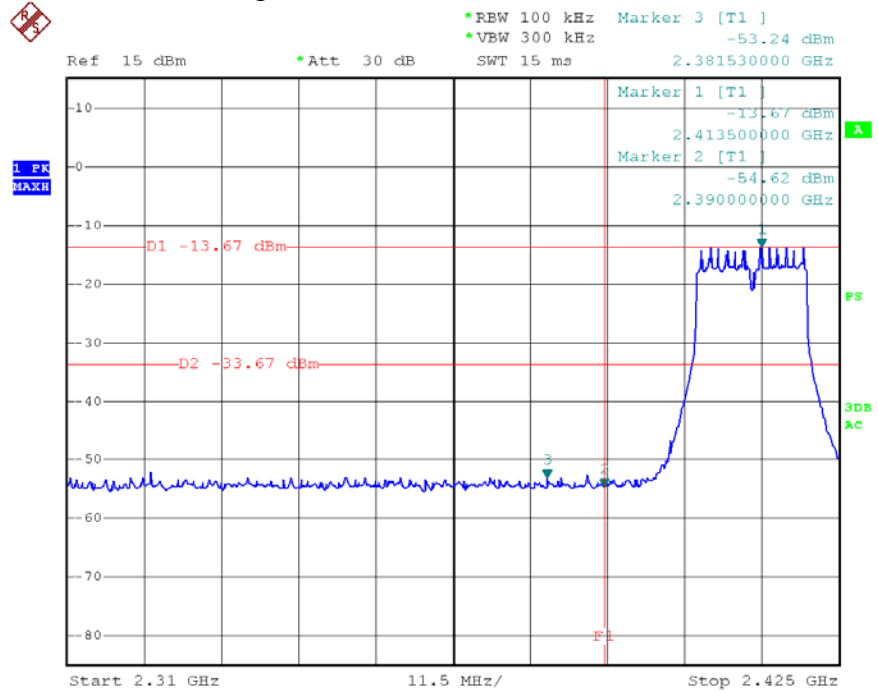

Date: 14.OCT.2013 16:45:20

Test Mode: 802.11g ---High

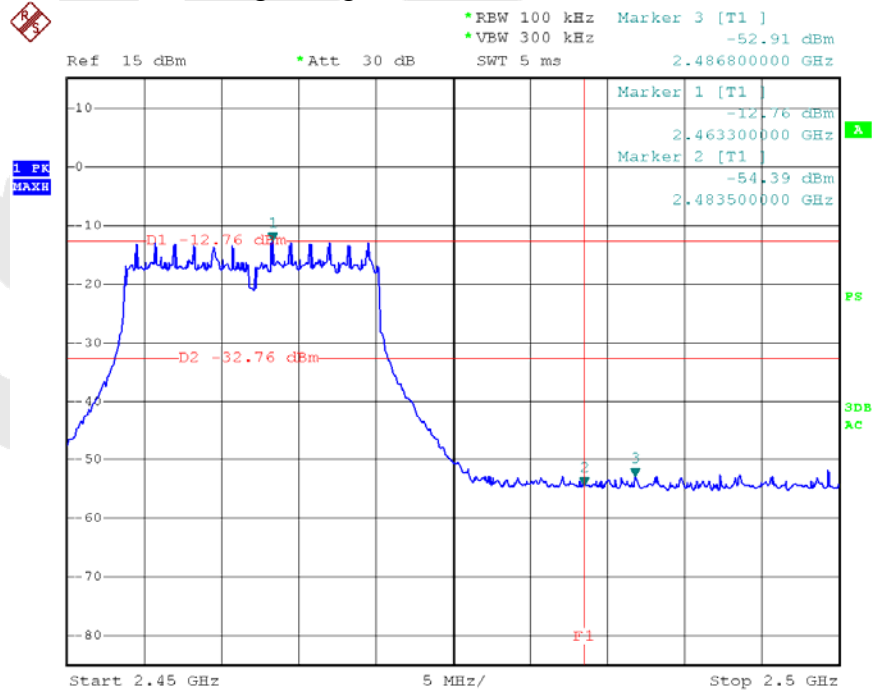

Date: 14.OCT.2013 16:47:30

Test Mode: 802.11n (HT20) ---Low

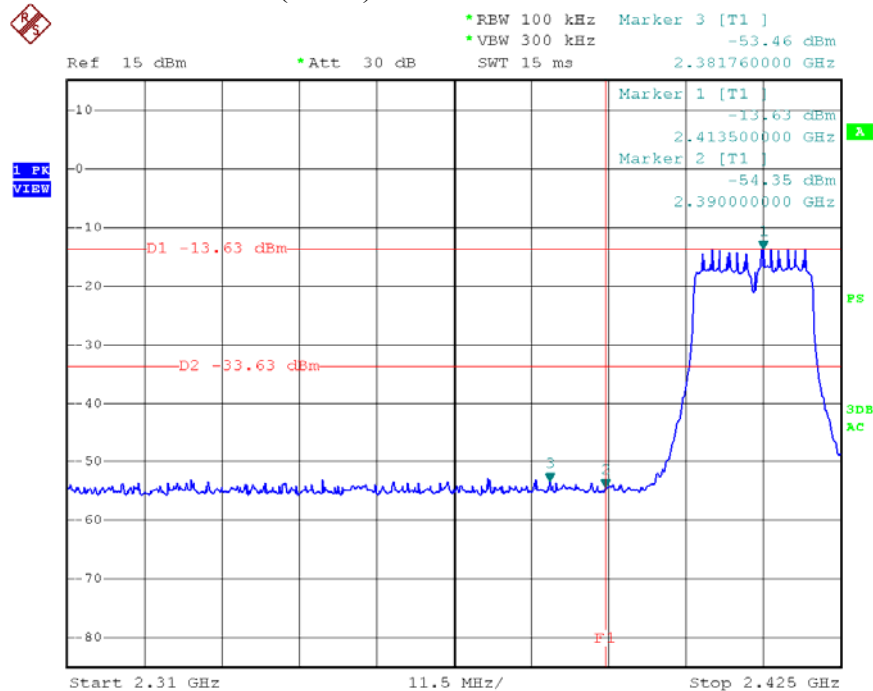

Date: 14.OCT.2013 16:49:28

Test Mode: 802.11n (HT20)---High

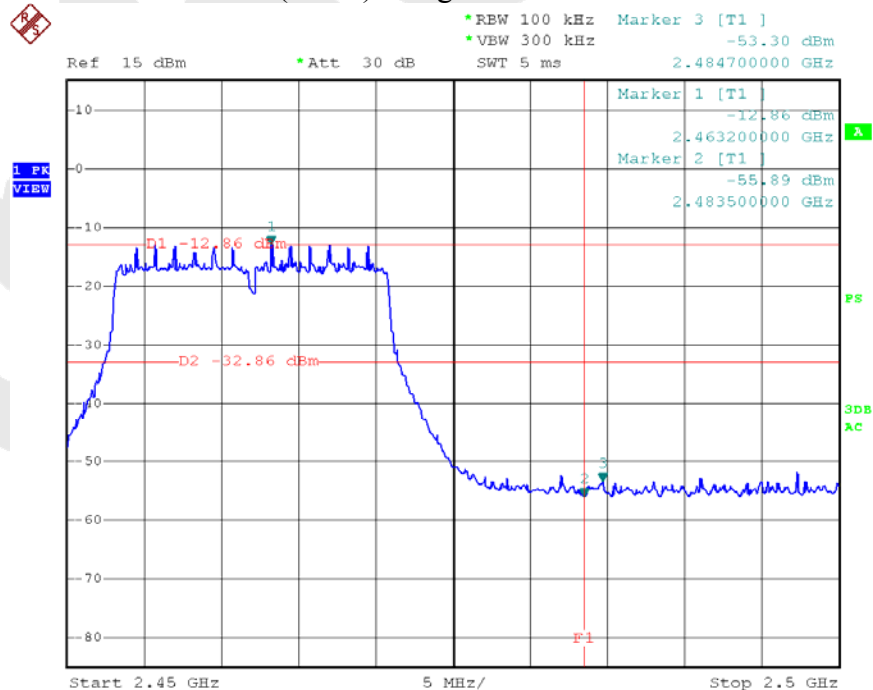

Date: 14.OCT.2013 16:51:41

Test Mode: 802.11n (HT40) ---Low

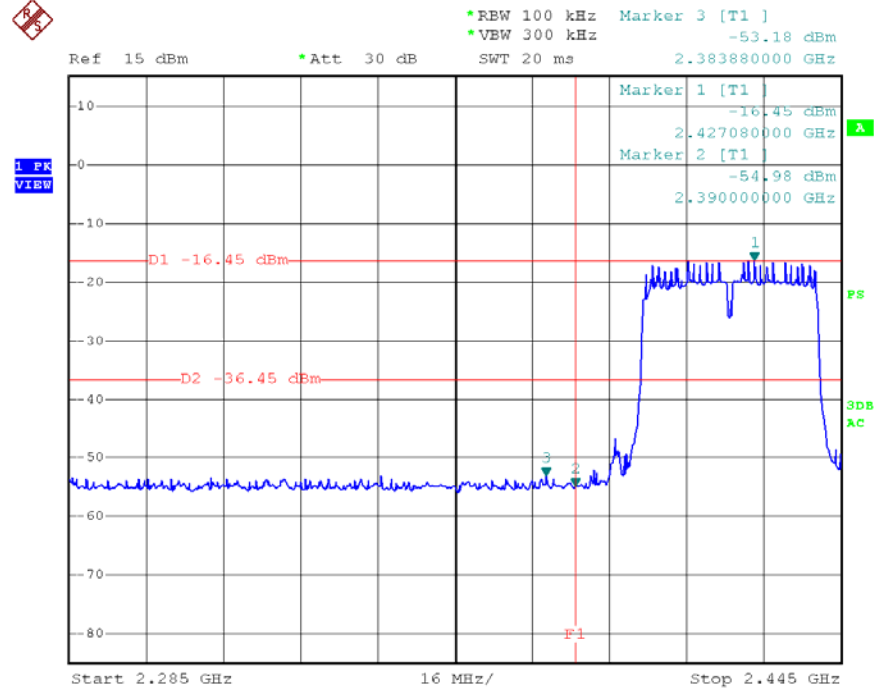

Date: 14.OCT.2013 16:54:11

Test Mode: 802.11n (HT40) ---High

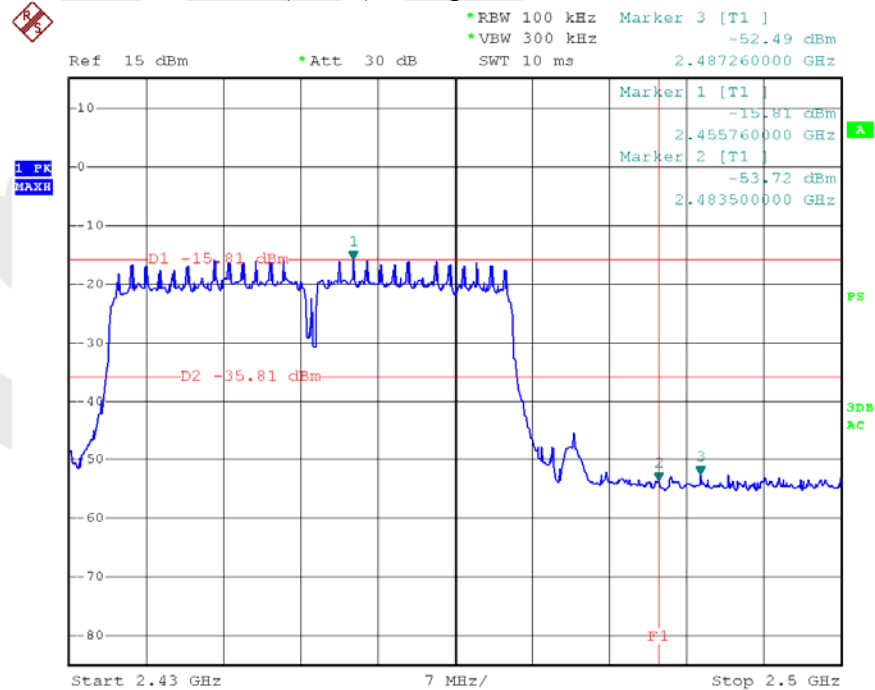

Date: 14.OCT.2013 16:57:08



#### 4.5. Peak Power Spectral Density

**a. Limit**

1. For direct sequence systems, the peak power spectral density conducted from the intentional radiator to the antenna shall not be greater than 8dBm in any 3kHz band during any time interval of continuous transmission.
2. The direct sequence operating of the hybrid system, with the frequency hopping operation turned off, shall comply with the power density requirements of paragraph (d) of this section.

**b. Test Procedure**

1. Place the EUT on the table and set it in transmitting mode. Remove the antenna from the EUT and then connect a low loss RF cable from the antenna port to the spectrum analyzer.
2. Set the spectrum analyzer as RBW = 3kHz, VBW = 10kHz, Span = 1.5MHz, Sweep=500s
3. Record the max. reading.
4. Repeat the above procedure until the measurements for all frequencies are completed.

**c. Test Equipment**

Same as the equipment listed in 4.2.

**d. Test Setup**

See 4.1

**e. Test Results**

Pass

**f. Test Data**

Please refer to the following data.

Anbotek

Test mode: IEEE 802.11b

Channel	Frequency (MHz)	PPSD (dBm/3KHz)	ΣPPSD (dBm/3KHz)	Limit (dBm)	Result
Low	2412	-22.15	-	8.00	Pass
Mid	2437	-20.80	-		Pass
High	2462	-20.88	-		Pass

Test mode: IEEE 802.11g

Channel	Frequency (MHz)	PPSD (dBm)	ΣPPSD (dBm)	Limit (dBm)	Result
Low	2412	-29.43	-	8.00	Pass
Mid	2437	-25.26	-		Pass
High	2462	-24.92	-		Pass

Test mode: IEEE 802.11n (HT20)

Channel	Frequency (MHz)	PPSD (dBm/3KHz)	ΣPPSD (dBm/3KHz)	Limit (dBm)	Result
Low	2412	-25.77	-	8.00	Pass
Mid	2437	-25.27	-		Pass
High	2462	-24.78	-		Pass

Test mode: IEEE 802.11n (HT40)

Channel	Frequency (MHz)	PPSD (dBm/3KHz)	ΣPPSD (dBm/3KHz)	Limit (dBm)	Result
Low	2422	-25.83	-	8.00	Pass
Mid	2437	-29.28	-		Pass
High	2452	-25.16	-		Pass

g. Test Plot See the following pages  
802.11 b CH--Low

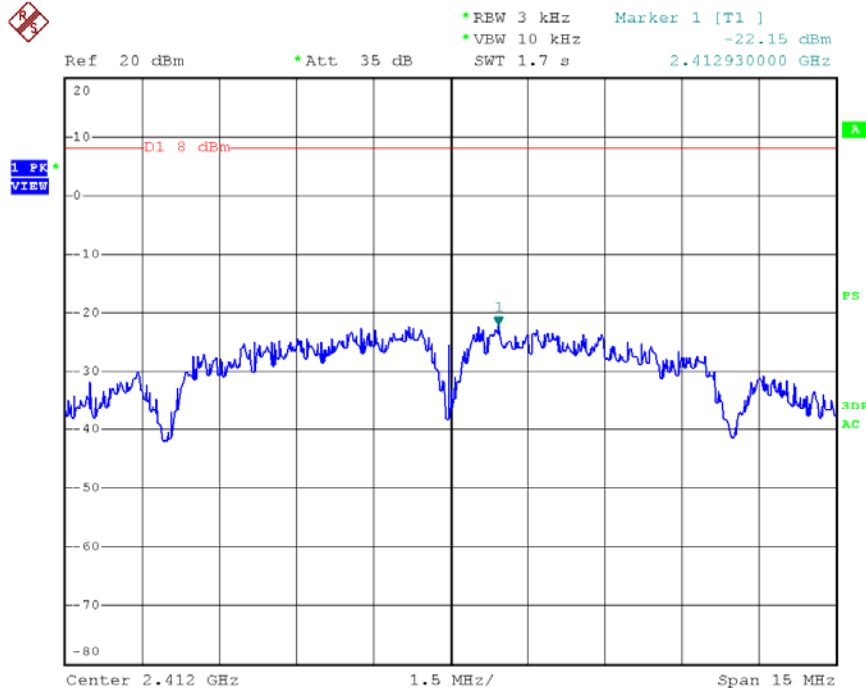

Date: 11.OCT.2013 14:49:44

802.11 b CH--Mid

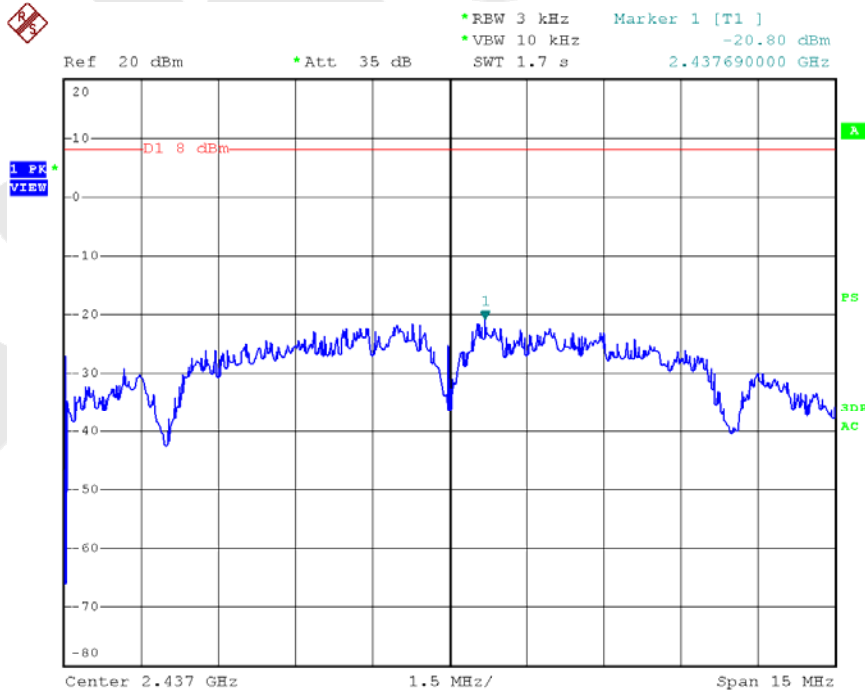

Date: 11.OCT.2013 14:50:42

802.11 b CH--High

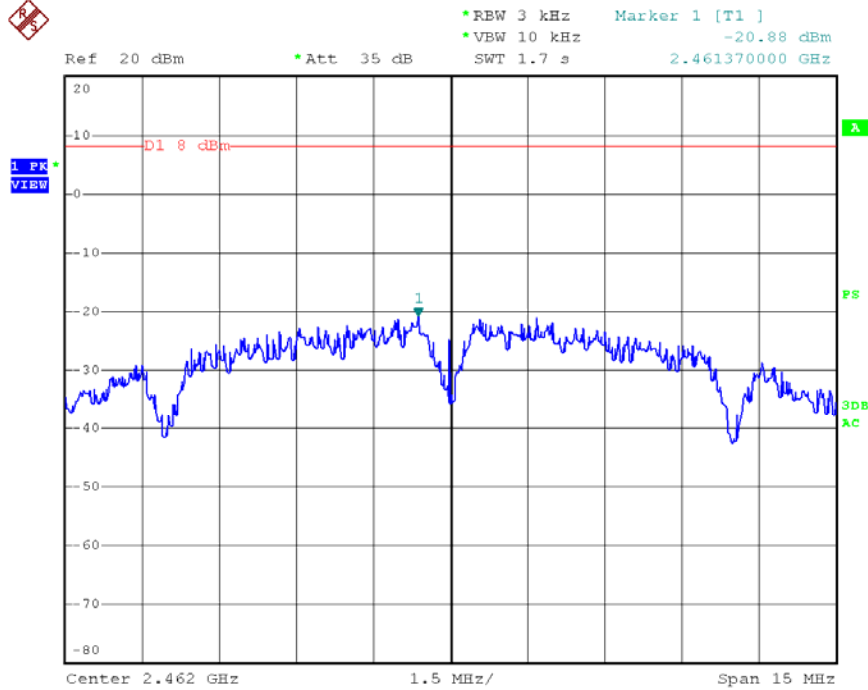

Date: 11.OCT.2013 14:51:23

802.11g CH--Low

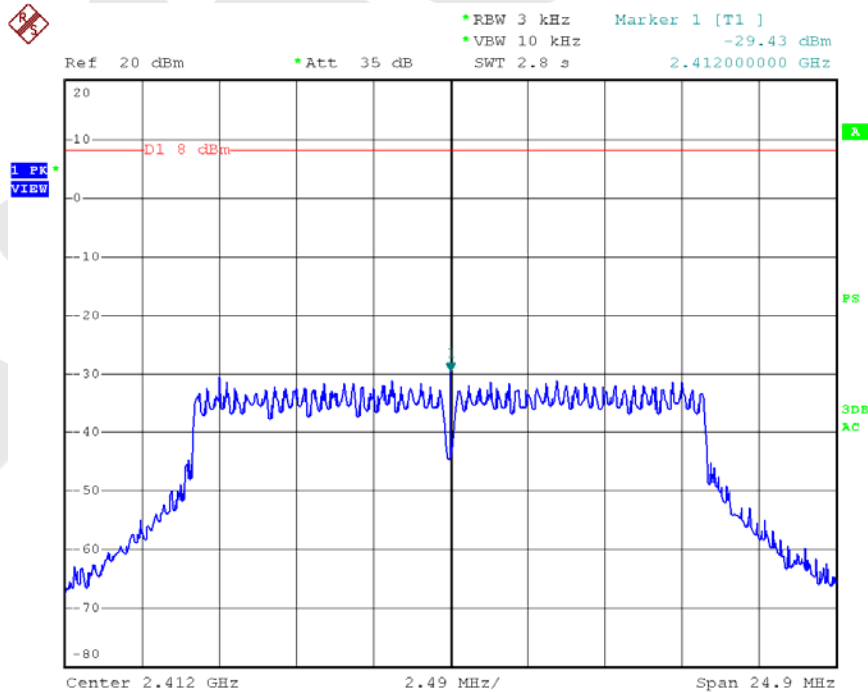

Date: 11.OCT.2013 14:55:34

802.11g CH--Mid

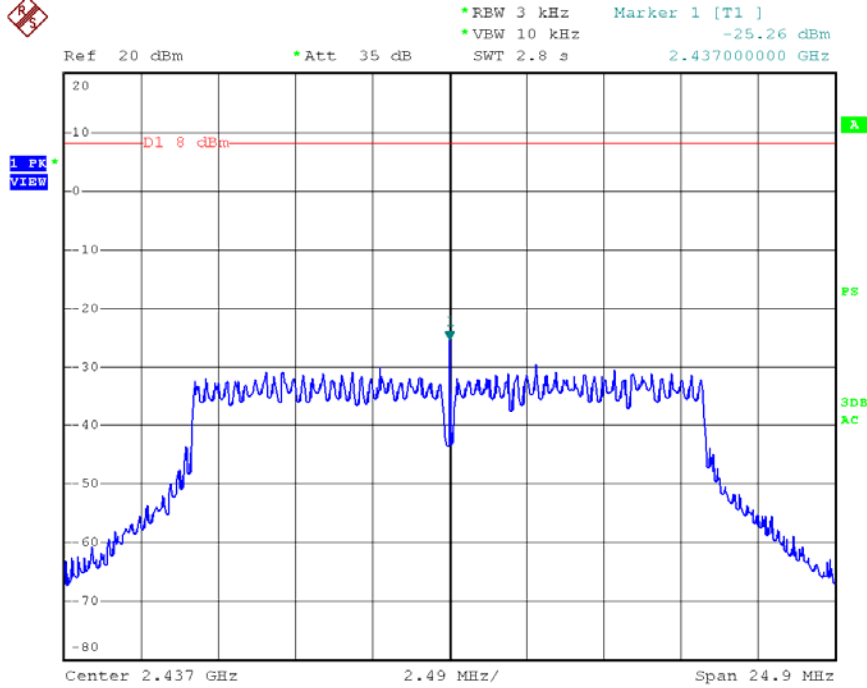

Date: 11.OCT.2013 14:56:35

802.11g CH--High

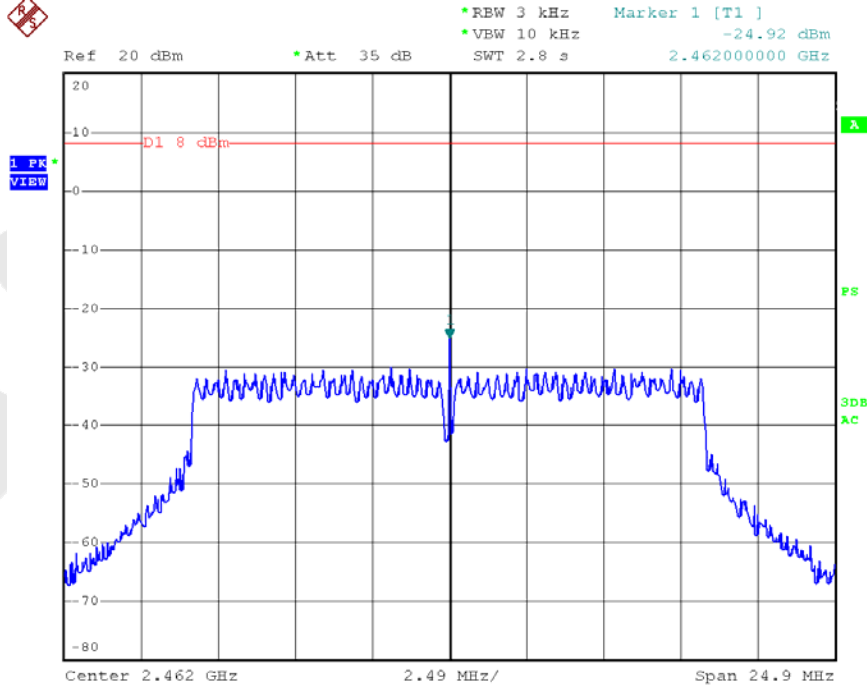

Date: 11.OCT.2013 14:57:20

802.11n (HT20) CH—Low

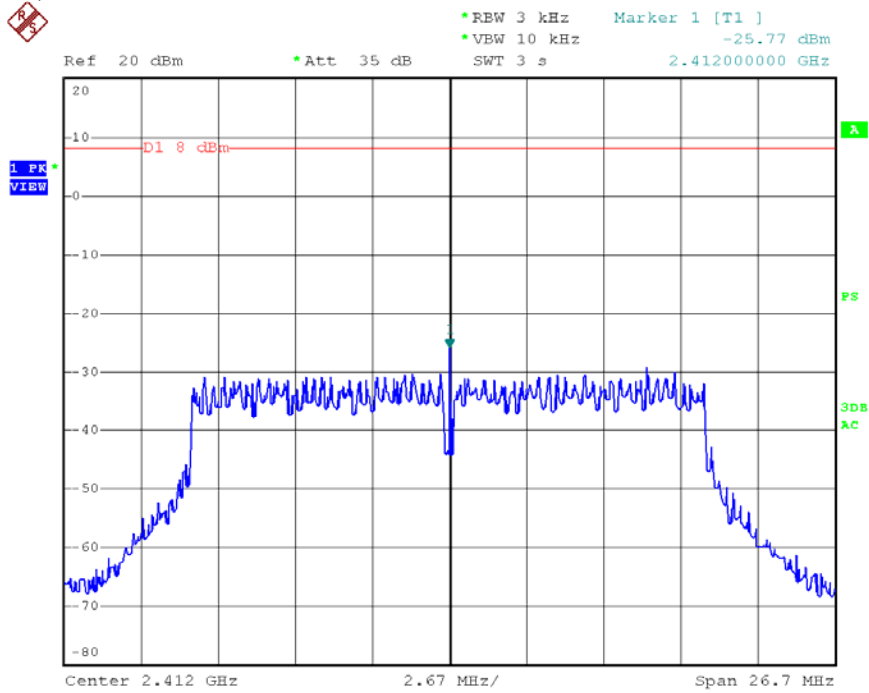

Date: 11.OCT.2013 15:00:11

802.11n (HT20) CH—Mid

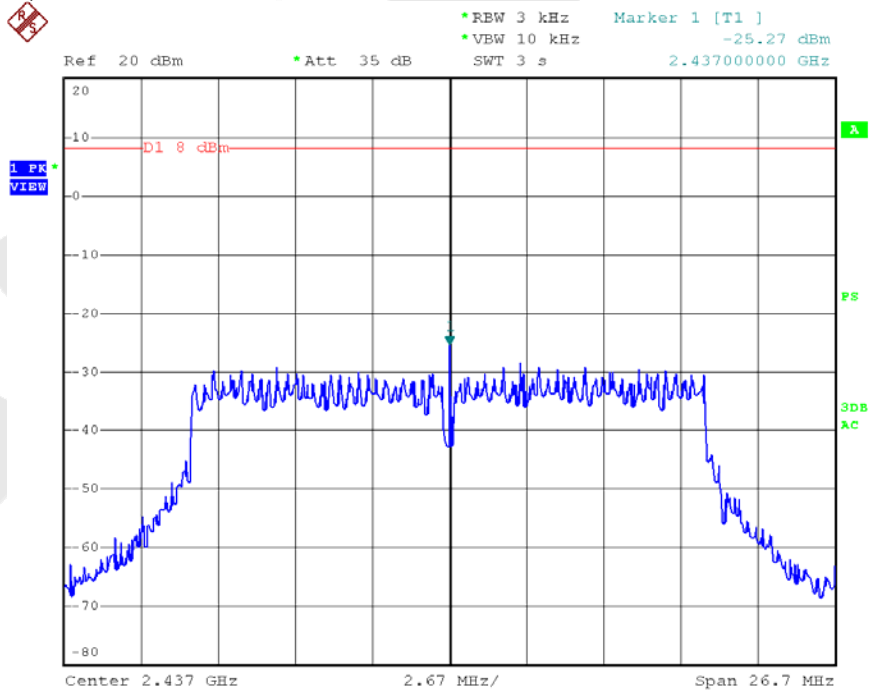

Date: 11.OCT.2013 15:00:55

802.11n (HT20) CH—High

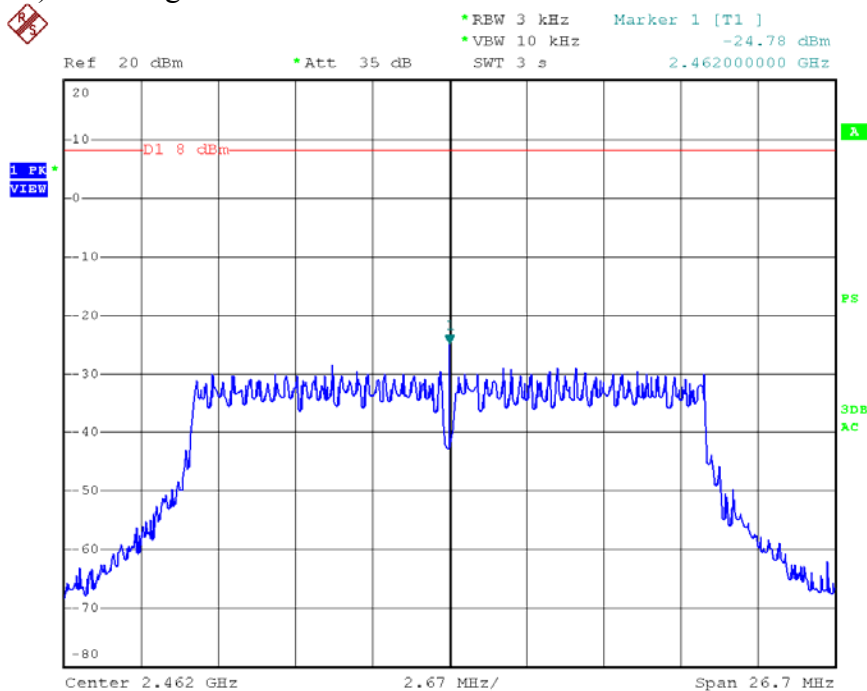

Date: 11.OCT.2013 15:02:13

802.11n (HT40) CH—Low

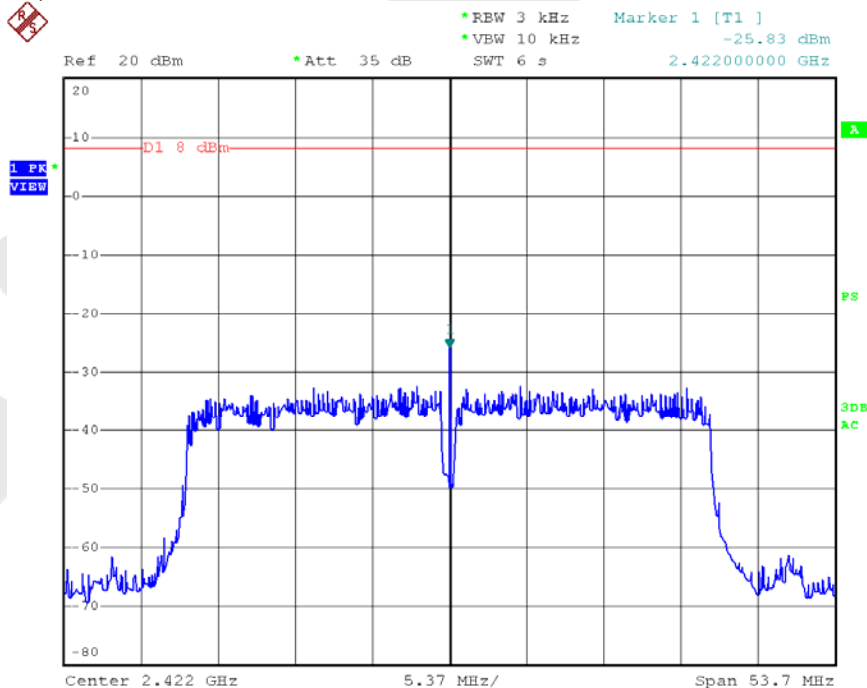

Date: 11.OCT.2013 15:03:20

802.11n (HT40) CH—Mid

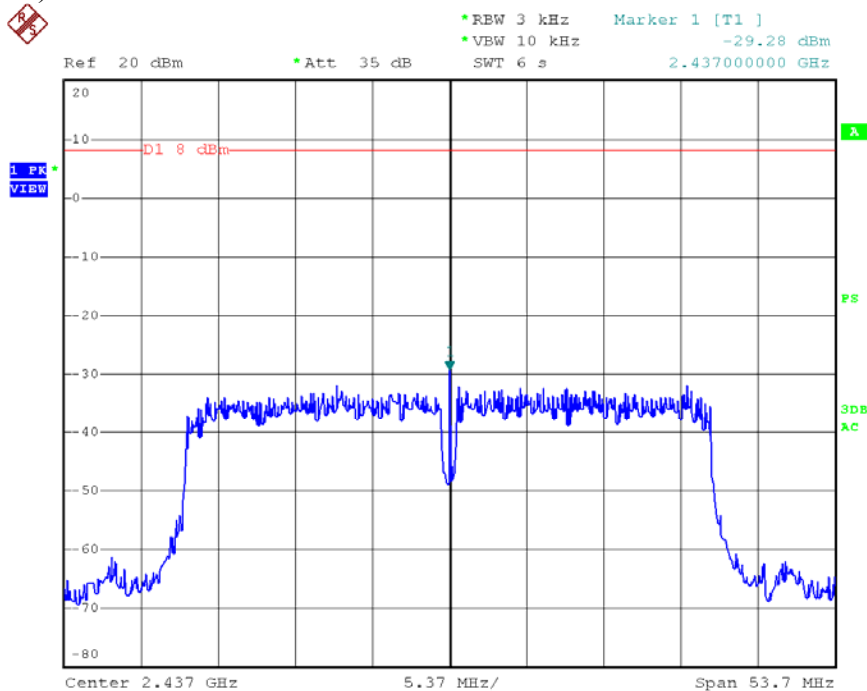

Date: 11.OCT.2013 15:04:28

802.11n (HT40) CH—High

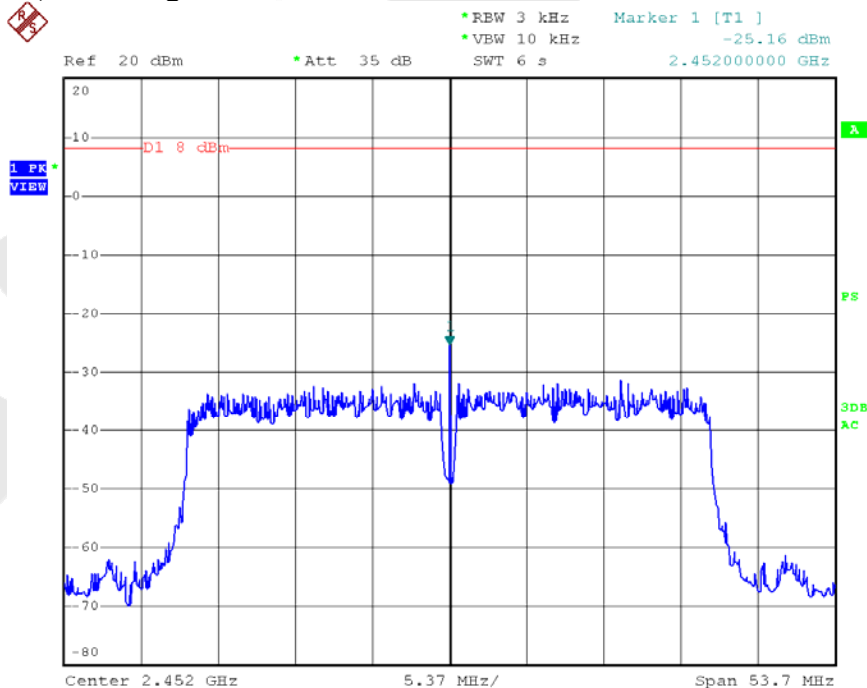

Date: 11.OCT.2013 15:05:10



#### 4.6. Radiated Emissions

##### 4.6.1.1. Test Limits (< 30 MHz)

Frequency (MHz)	Field Strength (microvolts/meter)	Measurement Distance (meter)
0.009-0.490	2400/F(kHz)	300
0.490-1.705	24000/F(kHz)	30
1.705-30.0	30	30

##### 4.6.1.2. Test Limits ( $\geq$ 30 MHz)

FIELD STRENGTH of Fundamental: @3M	FIELD STRENGTH of Harmonics	S15.209 30 - 88 MHz	40 dBuV/m
902-928 MHz		88 - 216 MHz	43.5
2.4-2.4835 GHz		216 - 960 MHz	46
94 dB $\mu$ V/m @3m	54 dB $\mu$ V/m @3m	ABOVE 960 MHz	54dBuV/m

In any 100 kHz bandwidth outside the frequency band in which the spread spectrum or digitally modulated intentional radiator is operating, the radio frequency power that is produced by the intentional radiator shall be at least 20 dB below that in the 100 kHz bandwidth within the band that contains the highest level of the desired power, based on either an RF conducted or a radiated measurement. Attenuation below the general limits specified in Section 15.209(a) is not required. In addition, radiated emissions which fall in the restricted bands, as defined in Section 15.205(a), must also comply with the radiated emission limits specified in Section 15.209(a) (see Section 15.205(c)).

##### Test Equipment

Item	Equipment	Manufacturer	Model No.	Serial No.	Last Cal.	Cal. Interval
1.	Preamplifier	Instruments corporation	EMC011830	980100	Aug. 09, 2013	1 Year
2.	EMI Test Receiver	Rohde & Schwarz	ESPI	101604	Apr. 23, 2013	1 Year
3.	Double Ridged Horn Antenna	Instruments corporation	GTH-0118	351600	Aug. 09, 2013	3 Year
4.	Bilog Broadband Antenna	Schwarzbeck	VULB9163	VULB 9163-289	Apr. 23, 2013	3 Year
5.	Pre-amplifier	SONOMA	310N	186860	Apr. 23, 2013	1 Year
6.	EMI Test Software EZ-EMC	SHURPLE	N/A	N/A	N/A	N/A

4.6.2. Test Configuration:

4.6.2.1. 9k to 30MHz emissions:

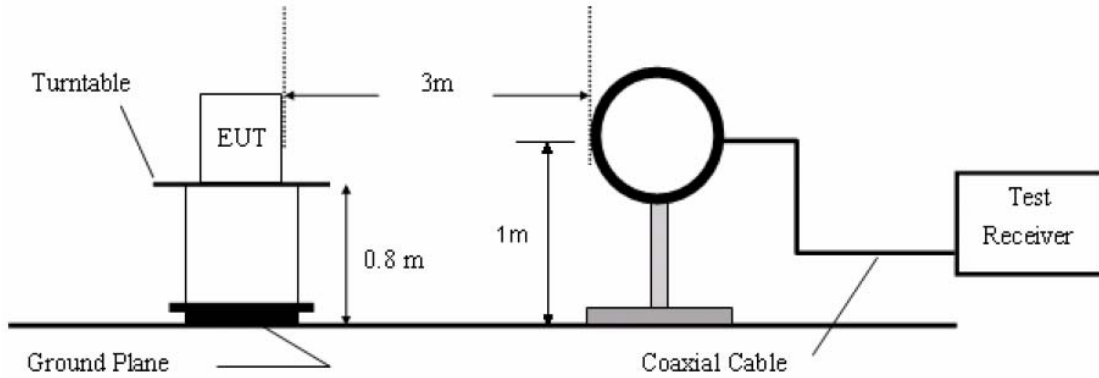

4.6.2.2. 30M to 1G emissions:

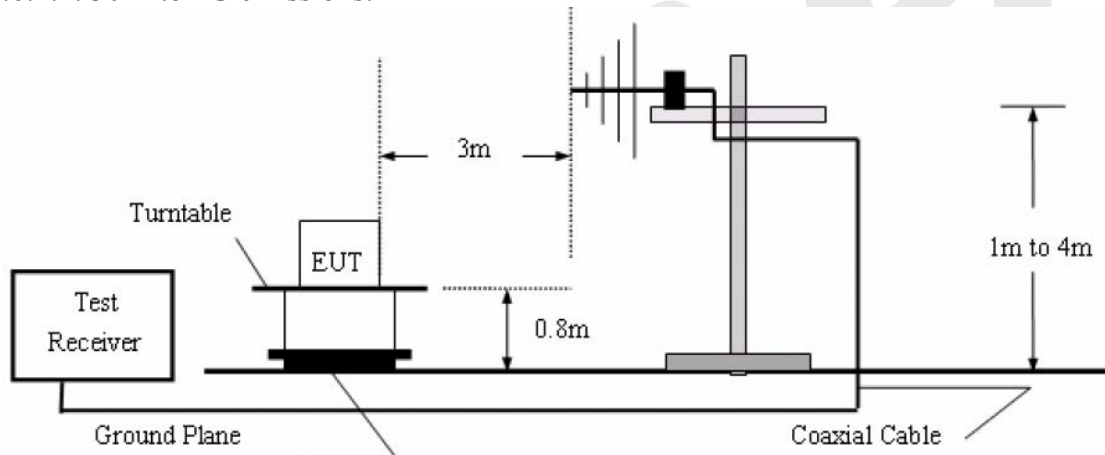

4.6.2.3. 1G to 40G emissions:

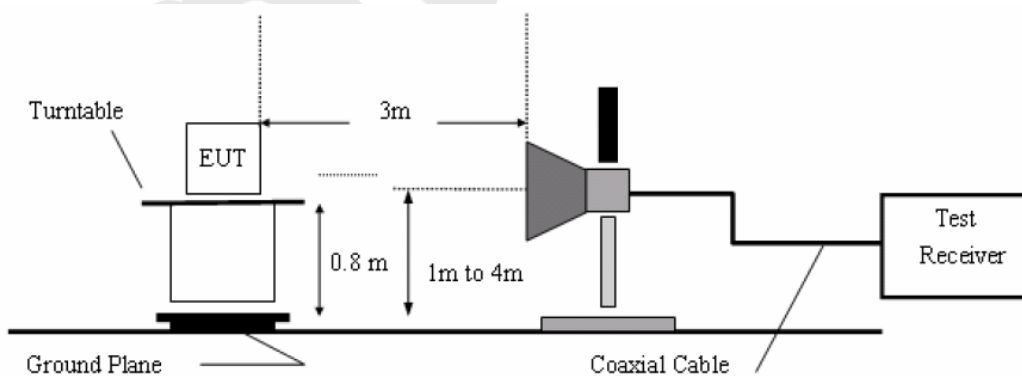

#### 4.6.3. Test Procedure

The EUT is placed on a turn table which is 0.8 meter high above the ground. The turn table can rotate 360 degrees to determine the position of the maximum emission level. The EUT is set 3 meters away from the receiving antenna which is mounted on a antenna tower. The antenna can be moved up and down from 1 to 4 meters to find out the maximum emission level. Both horizontal and vertical polarization of the antenna are set on test.

Measurements are made on 9KHz to 30MHz and 30MHz to 26GHz range with the transmitter set to the lowest, middle, and highest channels.

All readings from 30MHz to 1GHz are quasi-peak values with a resolution bandwidth of 120kHz. All reading are above 1GHz, peak & average values with a resolution bandwidth of 1MHz.

The EUT is tested in 9\*6\*6 Chamber.

The test results are listed in Section 4.6.4.

4.6.4. Test Results

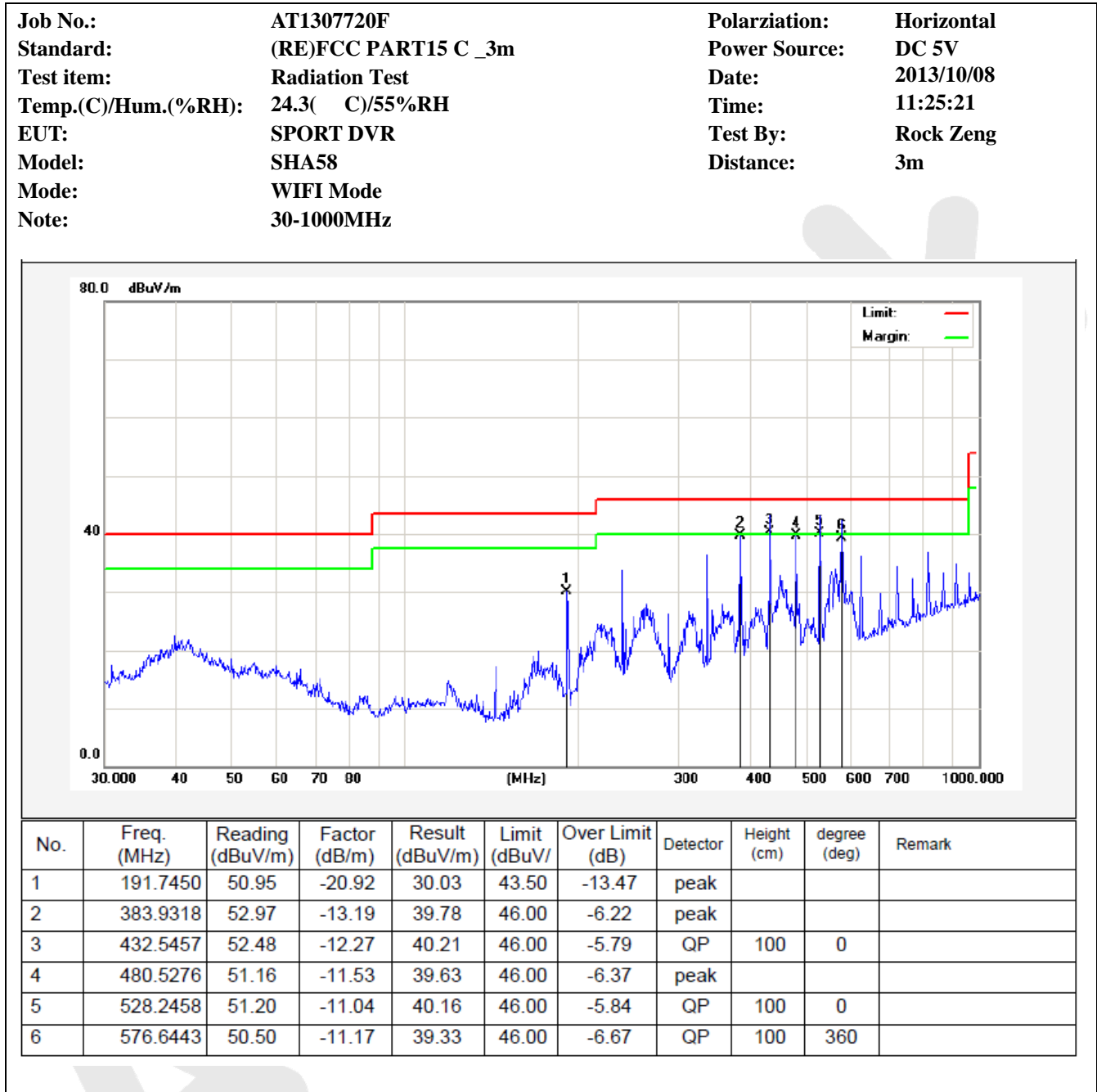

<b>Job No.:</b>	<b>AT1307720F</b>	<b>Polarziation:</b>	<b>Vertical</b>
<b>Standard:</b>	<b>(RE)FCC PART15 C _3m</b>	<b>Power Source:</b>	<b>DC 5V</b>
<b>Test item:</b>	<b>Radiation Test</b>	<b>Date:</b>	<b>2013/10/08</b>
<b>Temp.(C)/Hum.(%RH):</b>	<b>24.3( C)/55%RH</b>	<b>Time:</b>	<b>1:28:04</b>
<b>EUT:</b>	<b>SPORT DVR</b>	<b>Test By:</b>	<b>Rock Zeng</b>
<b>Model:</b>	<b>SHA58</b>	<b>Distance:</b>	<b>3m</b>
<b>Mode:</b>	<b>WIFI</b>		
<b>Note:</b>	<b>30-1000MHz</b>		

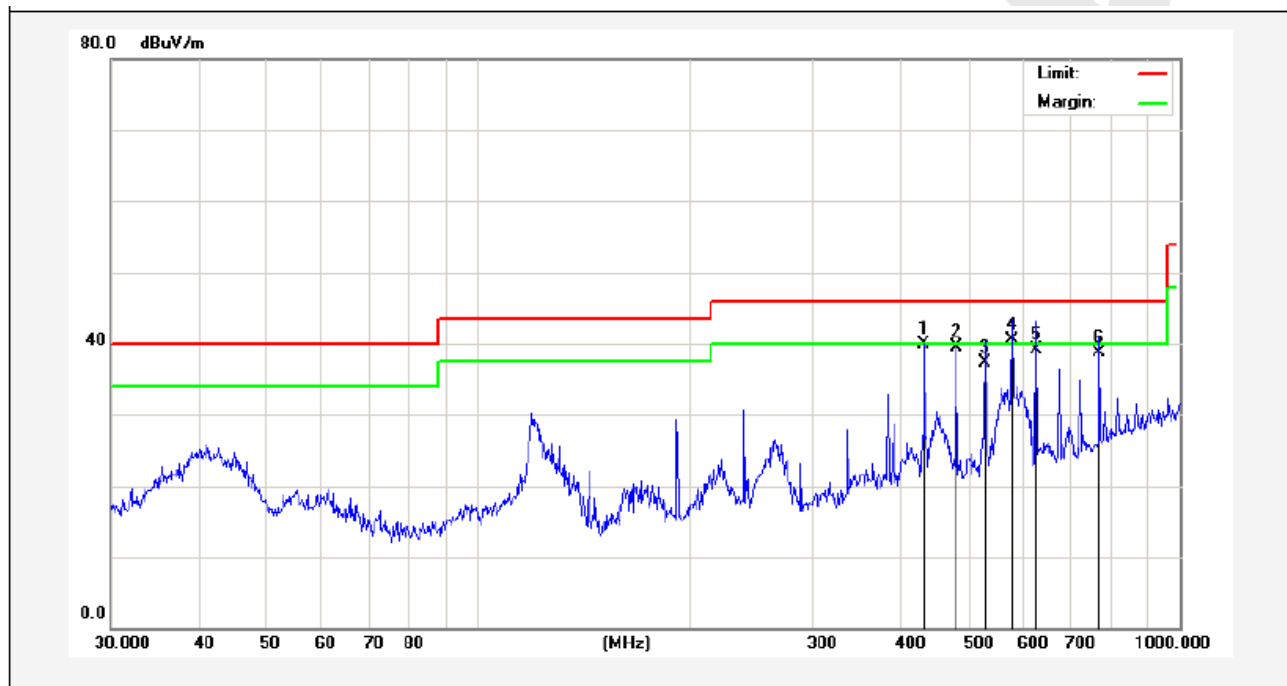

No.	Freq. (MHz)	Reading (dBuV/m)	Factor (dB/m)	Result (dBuV/m)	Limit (dBuV/)	Over Limit (dB)	Detector	Height (cm)	degree (deg)	Remark
1	432.5457	51.19	-11.24	39.95	46.00	-6.05	peak			
2	480.5276	50.97	-11.53	39.44	46.00	-6.56	peak			
3	528.2458	47.72	-10.47	37.25	46.00	-8.75	QP	100	0	
4	576.6443	50.12	-9.64	40.48	46.00	-5.52	QP	100	0	
5	625.0778	48.11	-9.05	39.06	46.00	-6.94	QP	100	360	
6	768.7481	45.23	-6.43	38.80	46.00	-7.20	QP	100	360	

**Above 1 GHz (The worst Mode)**

Operation Mode: TX / IEEE 802.11g / CH Low

Temperature: 25°C

Humidity: 50 % RH

Test Date: Oct. 08, 2013

Tested by: Rock Zeng

Polarity: Horizontal

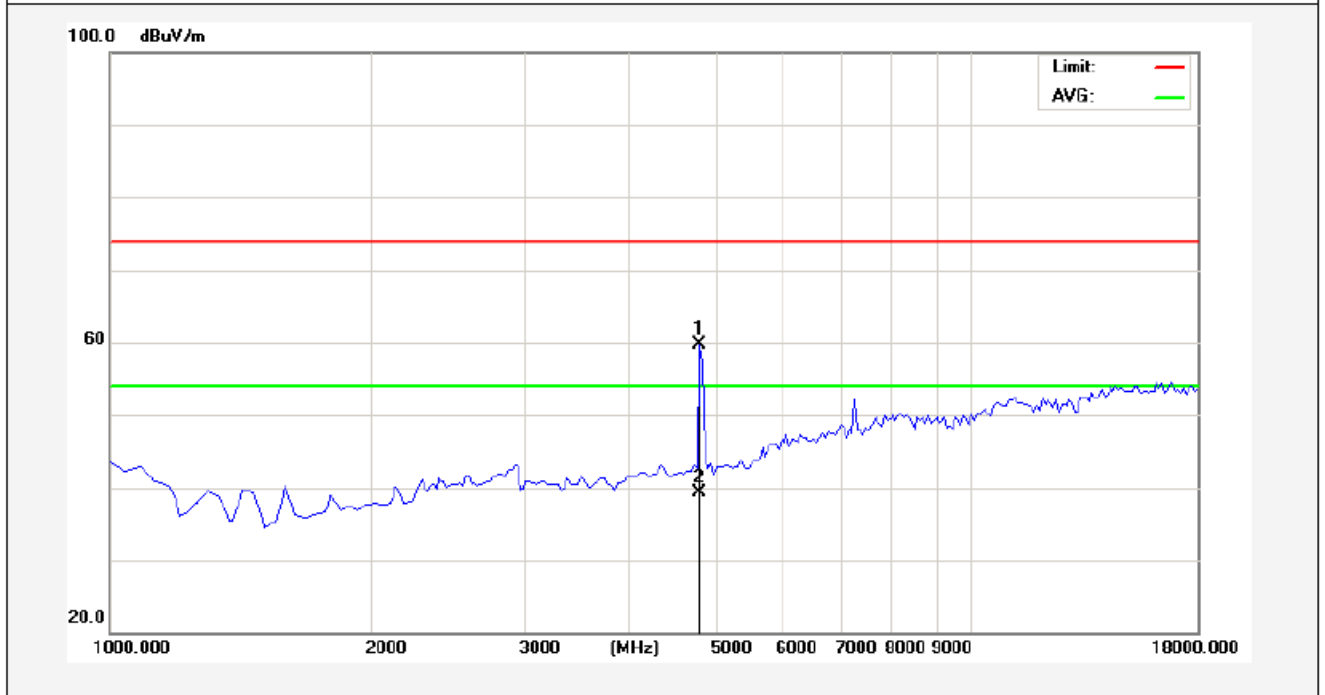

No.	Freq. (MHz)	Reading (dBuV/m)	Factor (dB/m)	Result (dBuV/m)	Limit (dBuV/)	Over Limit (dB)	Detector	Height (cm)	degree (deg)	Remark
1	4825.000	56.32	3.34	59.66	74.00	-14.34	peak			
2	4825.000	36.01	3.34	39.35	54.00	-14.65	AVG			

AMR

Operation Mode: TX / IEEE 802.11g / CH Low  
Temperature: 25°C  
Humidity: 50 % RH

Test Date: Oct. 08, 2013  
Tested by: Rock Zeng  
Polarity: Vertical

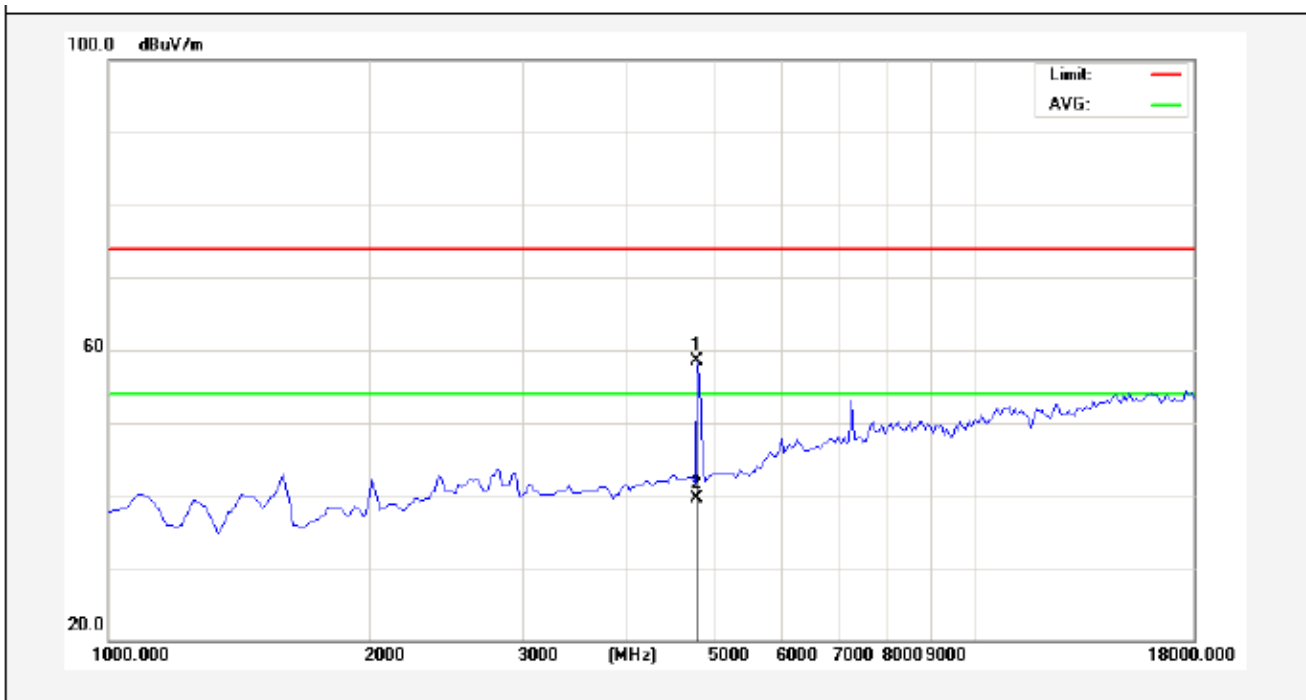

No.	Freq. (MHz)	Reading (dBuV/m)	Factor (dB/m)	Result (dBuV/m)	Limit (dBuV/)	Over Limit (dB)	Detector	Height (cm)	degree (deg)	Remark
1	4825.000	55.18	3.34	58.52	74.00	-15.48	peak			
2	4825.000	36.08	3.34	39.42	54.00	-14.58	AVG			

A M K

Operation Mode: TX / IEEE 802.11g / CH Mid  
Temperature: 25°C  
Humidity: 50 % RH

Test Date: Oct. 08, 2013  
Tested by: Rock Zeng  
Polarity: Horizontal

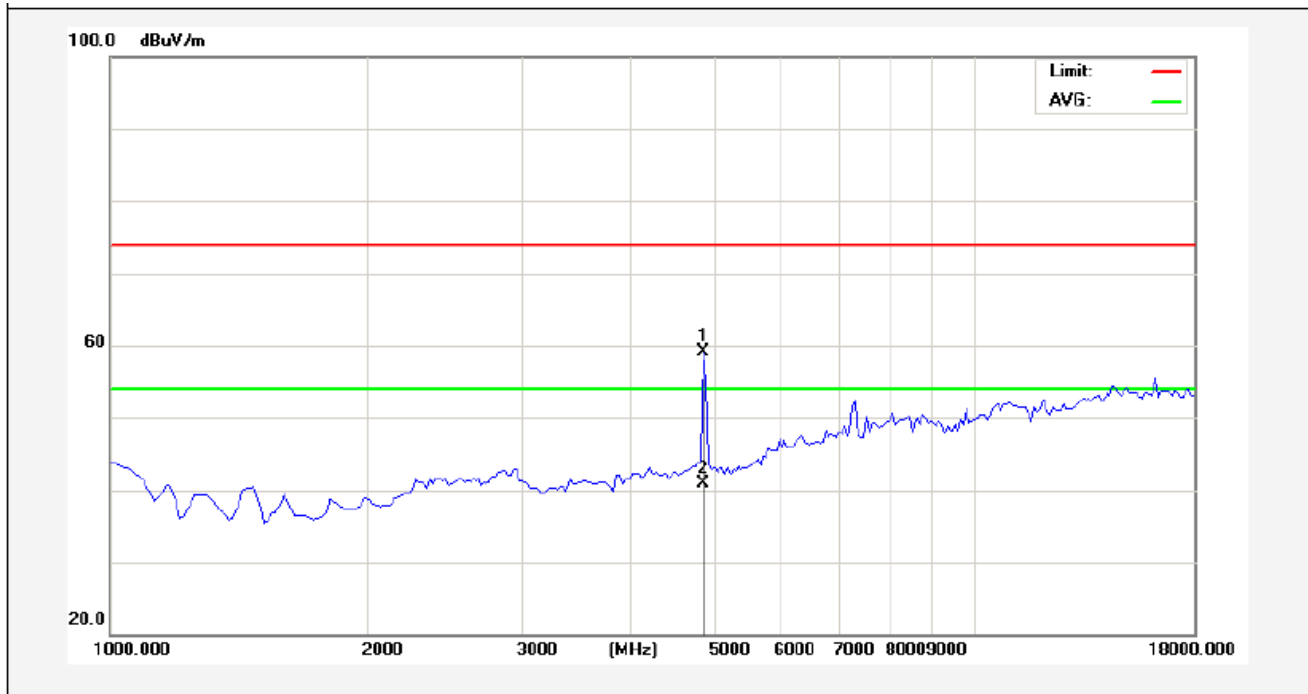

No.	Freq. (MHz)	Reading (dBuV/m)	Factor (dB/m)	Result (dBuV/m)	Limit (dBuV/)	Over Limit (dB)	Detector	Height (cm)	degree (deg)	Remark
1	4867.500	55.60	3.41	59.01	74.00	-14.99	peak			
2	4867.500	37.43	3.41	40.84	54.00	-13.16	AVG			

A M K



Operation Mode: TX / IEEE 802.11g / CH Mid  
Temperature: 25°C  
Humidity: 50 % RH

Test Date: Oct. 08, 2013  
Tested by: Rock Zeng  
Polarity: Vertical

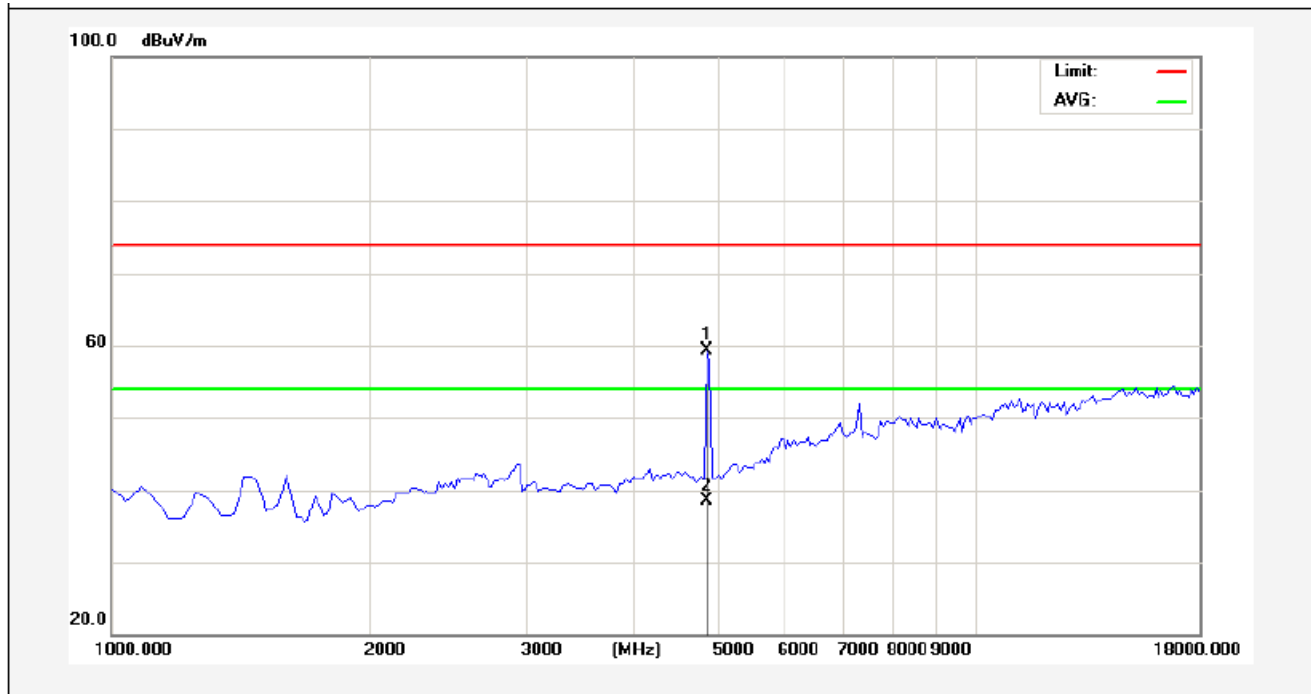

No.	Freq. (MHz)	Reading (dBuV/m)	Factor (dB/m)	Result (dBuV/m)	Limit (dBuV/)	Over Limit (dB)	Detector	Height (cm)	degree (deg)	Remark
1	4867.500	55.85	3.41	59.26	74.00	-14.74	peak			
2	4867.500	35.10	3.41	38.51	54.00	-15.49	AVG			

AMR

Operation Mode: TX / IEEE 802.11g / CH High  
Temperature: 25°C  
Humidity: 50 % RH

Test Date: Oct. 08, 2013  
Tested by: Rock Zeng  
Polarity: Horizontal

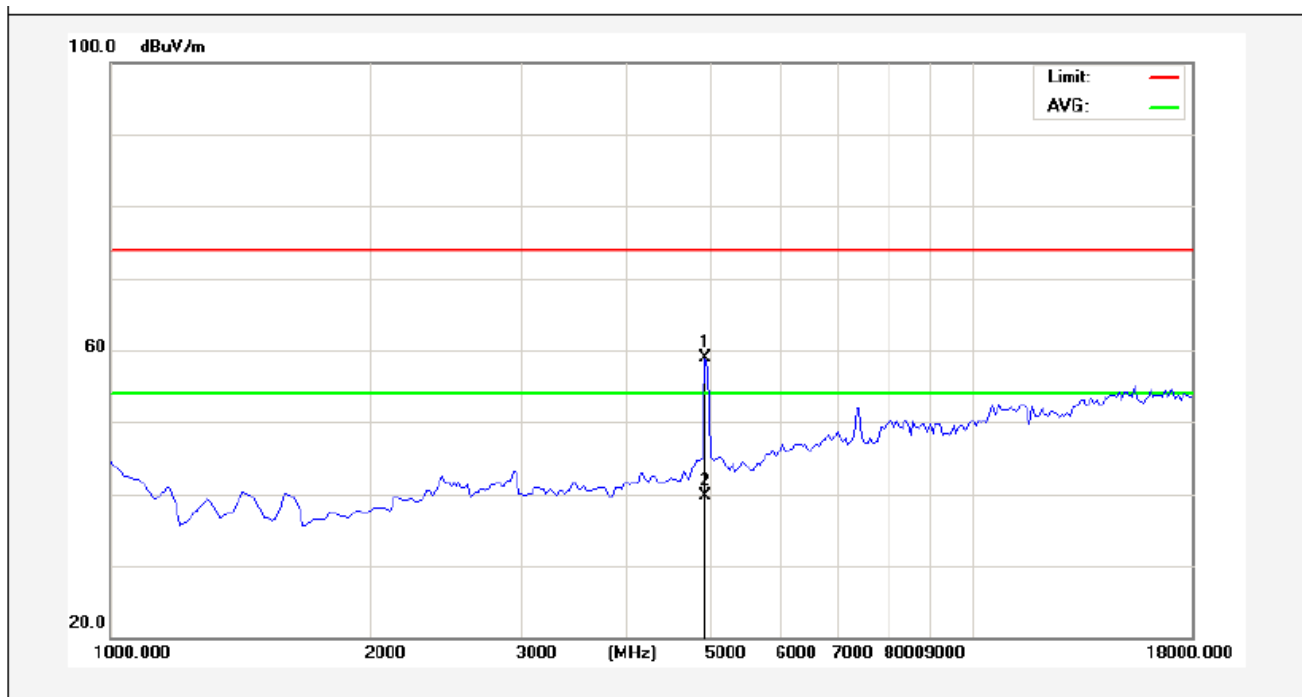

No.	Freq. (MHz)	Reading (dBuV/m)	Factor (dB/m)	Result (dBuV/m)	Limit (dBuV/)	Over Limit (dB)	Detector	Height (cm)	degree (deg)	Remark
1	4910.000	55.50	3.49	58.99	74.00	-15.01	peak			
2	4910.000	36.12	3.49	39.61	54.00	-14.39	AVG			

AMR

Operation Mode: TX / IEEE 802.11g / CH High  
Temperature: 25°C  
Humidity: 50 % RH

Test Date: Oct. 08, 2013  
Tested by: Rock Zeng  
Polarity: Vertical

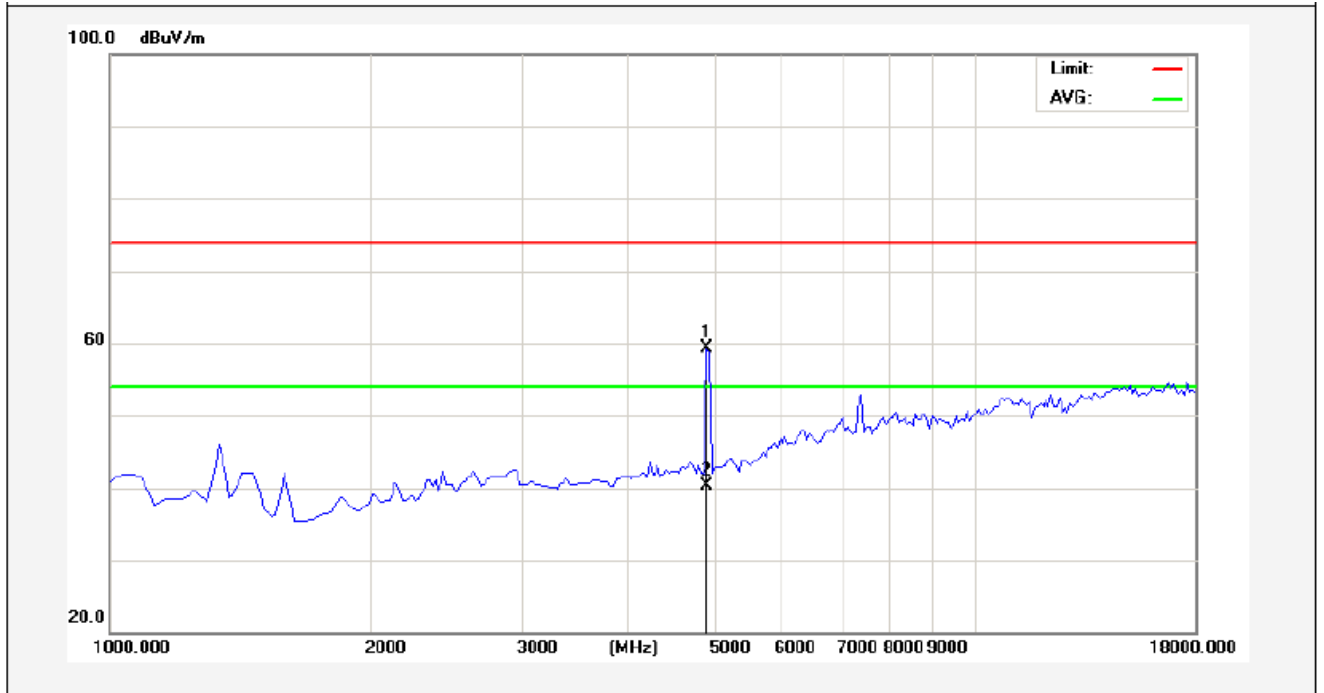

No.	Freq. (MHz)	Reading (dBuV/m)	Factor (dB/m)	Result (dBuV/m)	Limit (dBuV/)	Over Limit (dB)	Detector	Height (cm)	degree (deg)	Remark
1	4910.000	55.81	3.49	59.30	74.00	-14.70	peak			
2	4910.000	36.80	3.49	40.29	54.00	-13.71	AVG			

AMR

## 5. PHOTOGRAPH

### 5.1. Photo of Conducted Emission Measurement



### 5.2. Photo of Radiation Emission Test



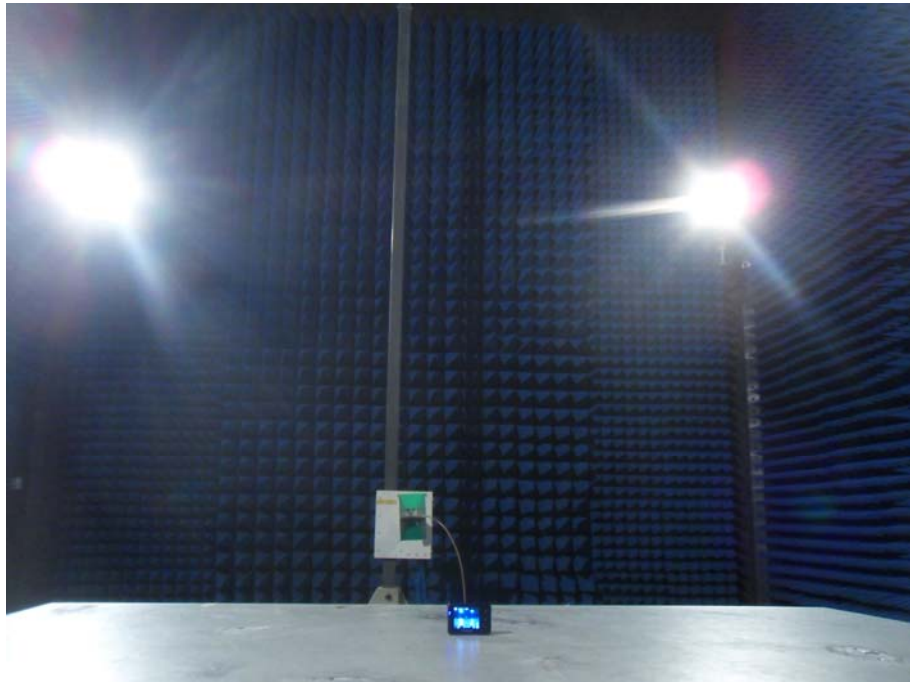

Anbotek

## Appendix I (External Photos)

Figure 1  
The EUT-Overall View



Figure 2  
The EUT-Front View



Figure 3  
The EUT-Back View



Figure 4  
The Label of Adapter View



## Appendix II (Internal Photos)

Figure 5  
The EUT-Inside View



Figure 6  
PCB of the EUT-Front View

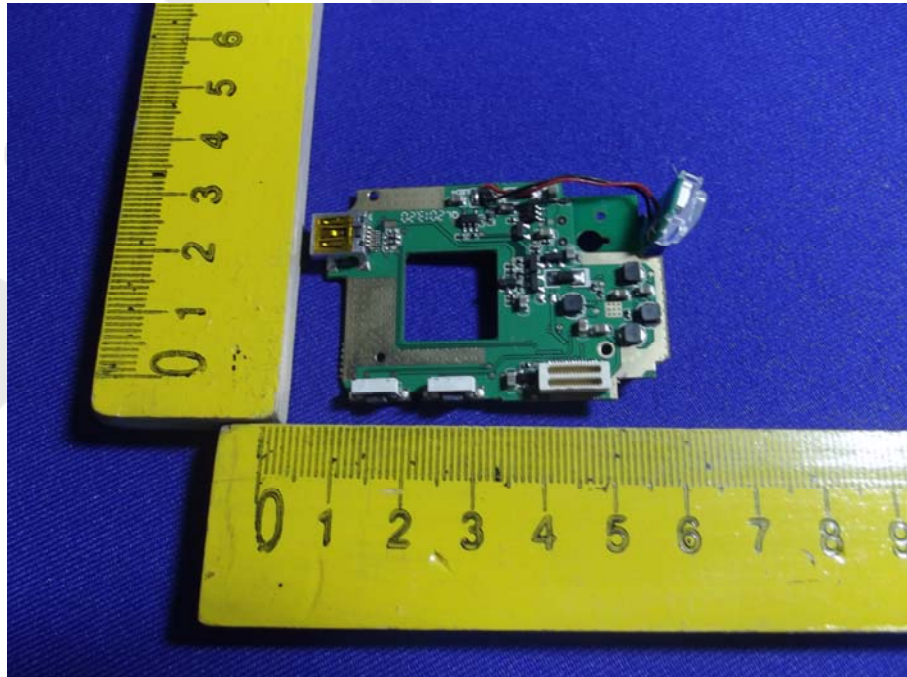



Figure 7  
PCB of the EUT-Back View

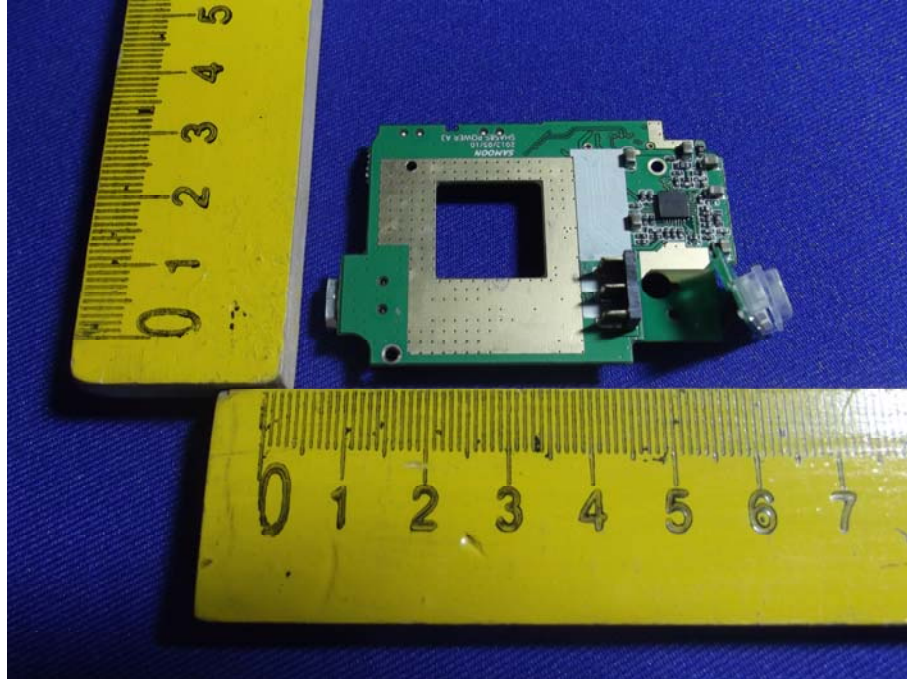

Figure 8  
PCB of the EUT-Front View

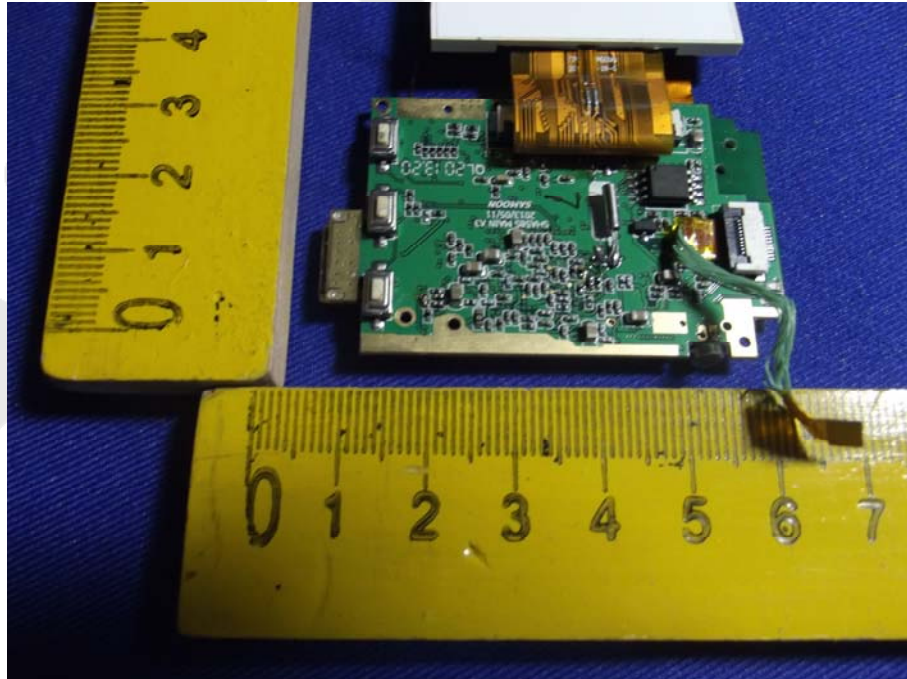

Figure 9  
PCB of the EUT-Back View

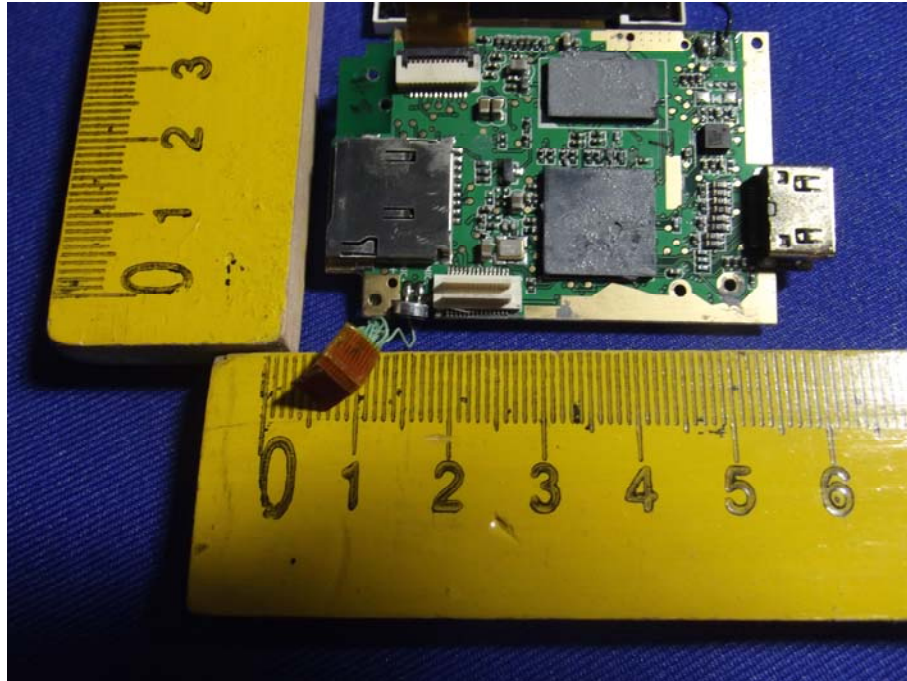

Figure 10  
PCB of the EUT-Front View (Shielding)



Figure 11  
PCB of the EUT-Back View



Figure 12  
PCB of the EUT-Front View

