

<b>Samoon technology Co.,Ltd</b>		
Title	SPCA6330	
Size	Document Number	Rev
A3	SPCA6330A RDK Main_BD Circuit	1.0
Date:	Tuesday, July 09, 2013	Sheet 3 of 12

# DSP POWER AND RESET

U1D

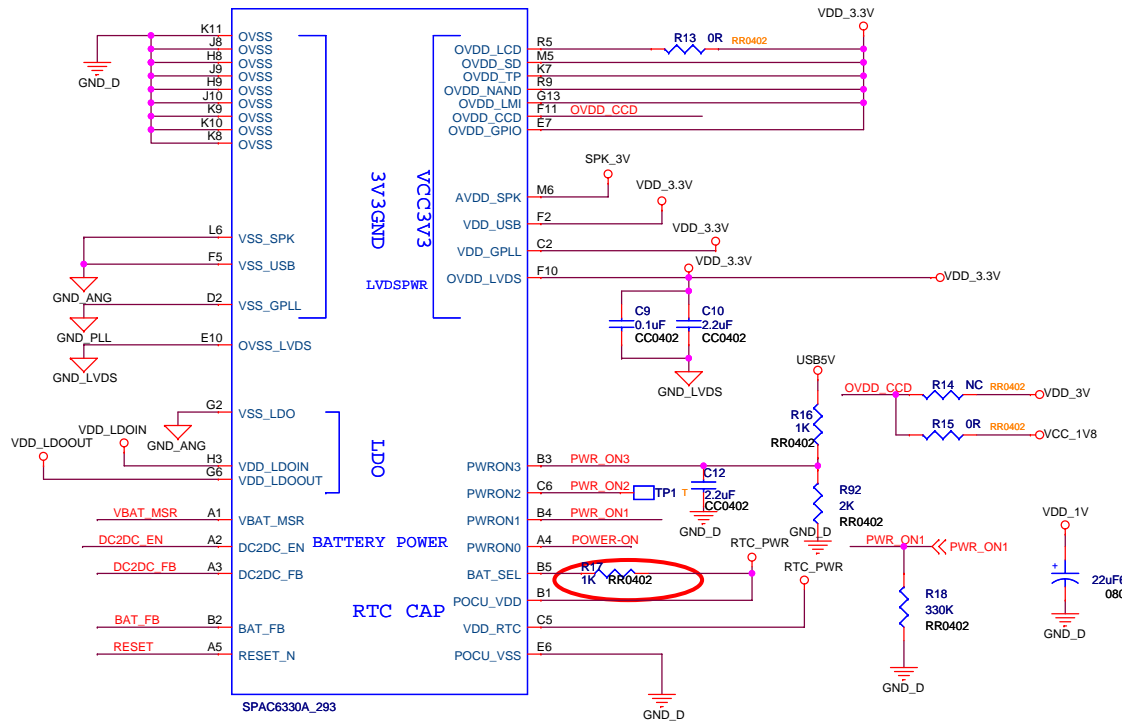

U1E

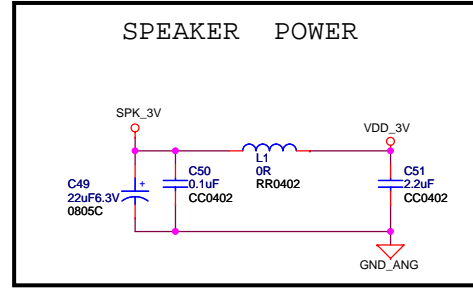
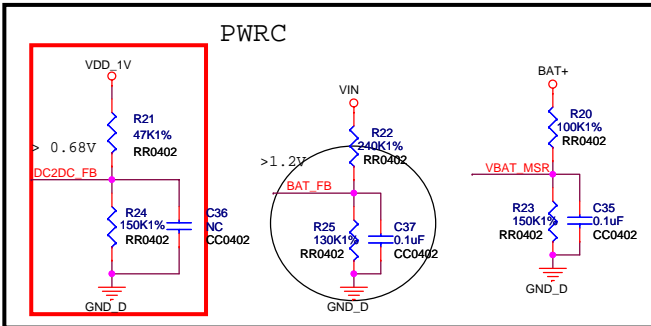
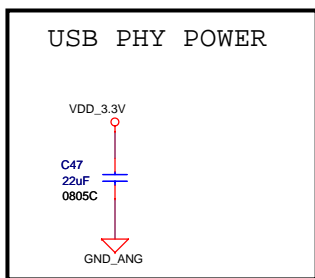
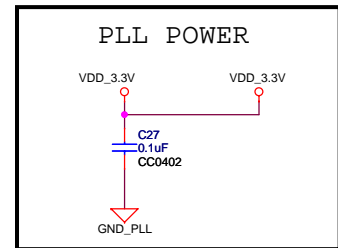
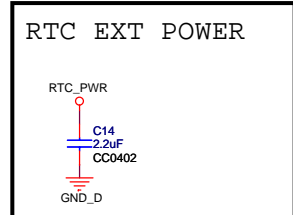
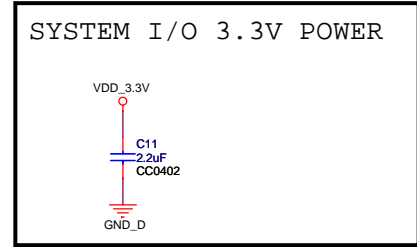
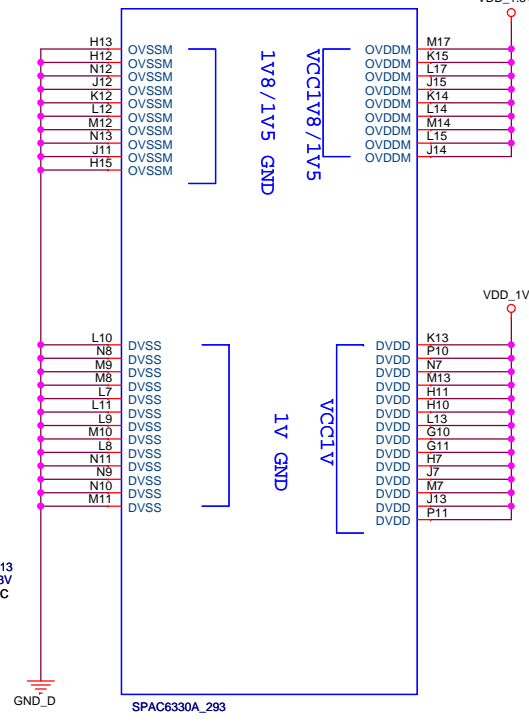

<b>Samoon technology Co.,Ltd</b>		
Title	SPCA6330	
Size	Document Number	Rev
A3	SPCA6330A RDK Main_BD Circuit	1.0
Date:	Tuesday, July 09, 2013	Sheet 4 of 12

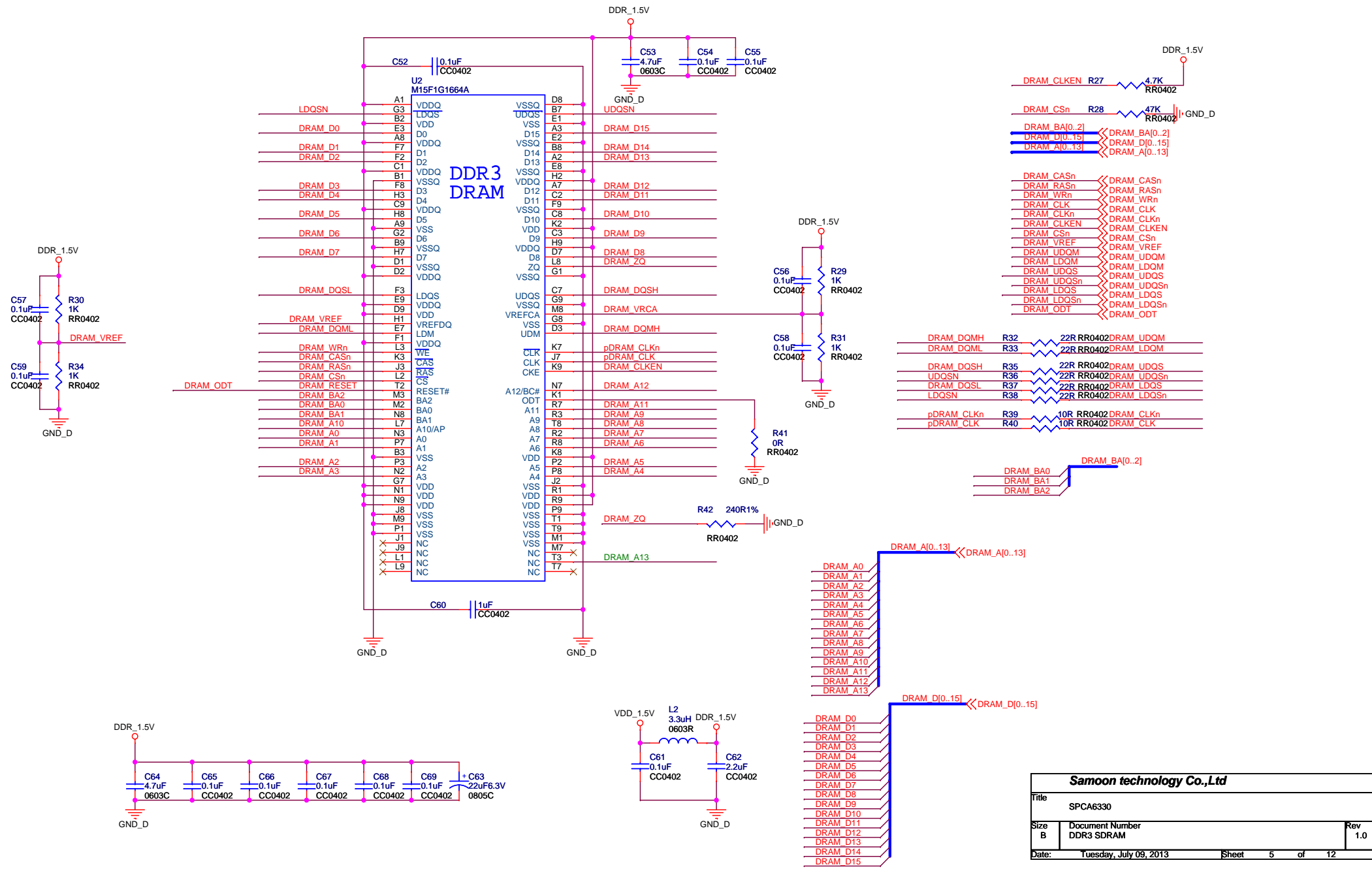

<b>Samoon technology Co.,Ltd</b>		
Title		
SPCA6330		
Size	Document Number	Rev
B	DDR3 SDRAM	1.0
Date:	Tuesday, July 09, 2013	Sheet 5 of 12

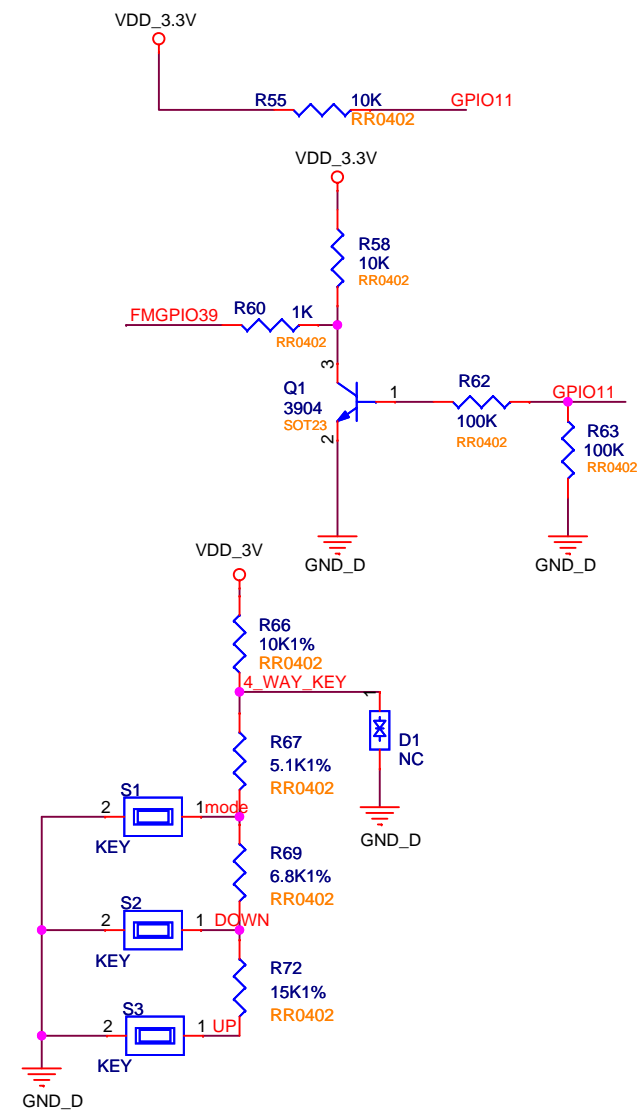
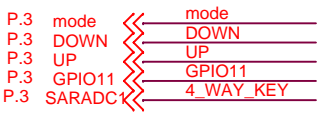
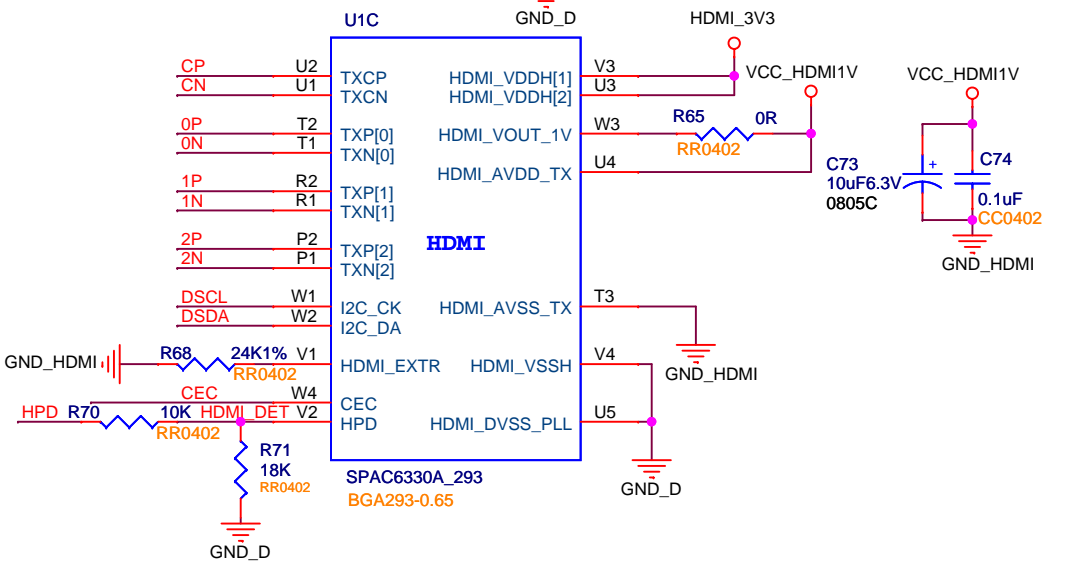
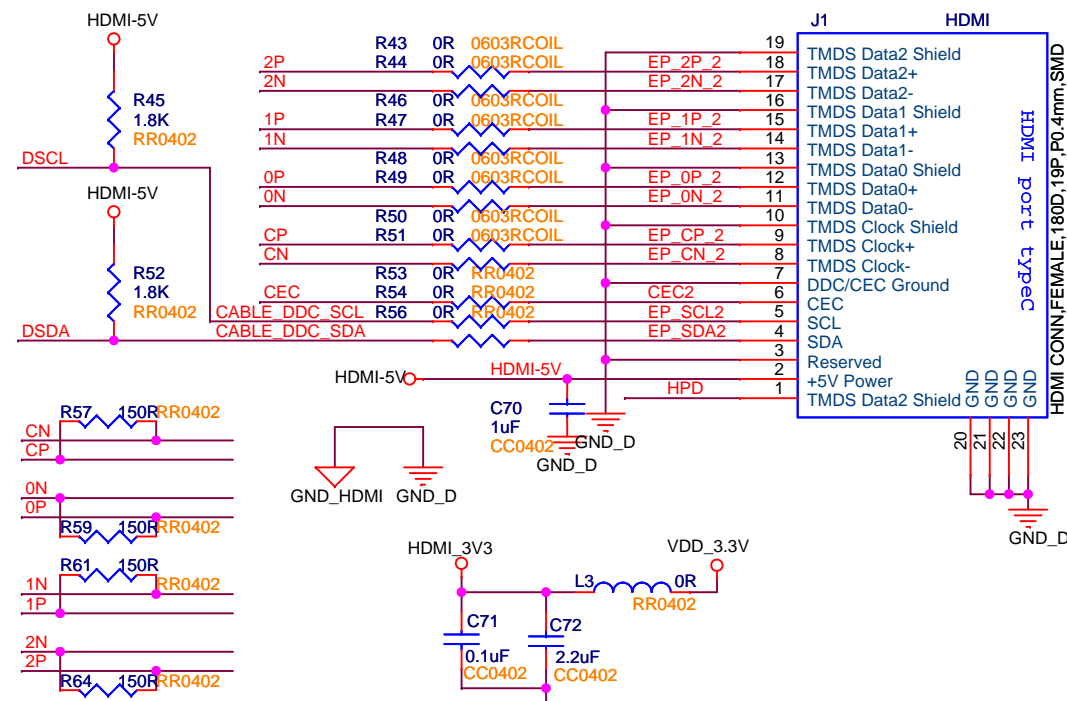

<b>Samoon technology Co.,Ltd</b>		
Title: SPCA6330		
Size: A4	Document Number: SPCA6330A HDMI	Rev: 1.0
Date: Tuesday, July 09, 2013	Sheet: 6	of 12





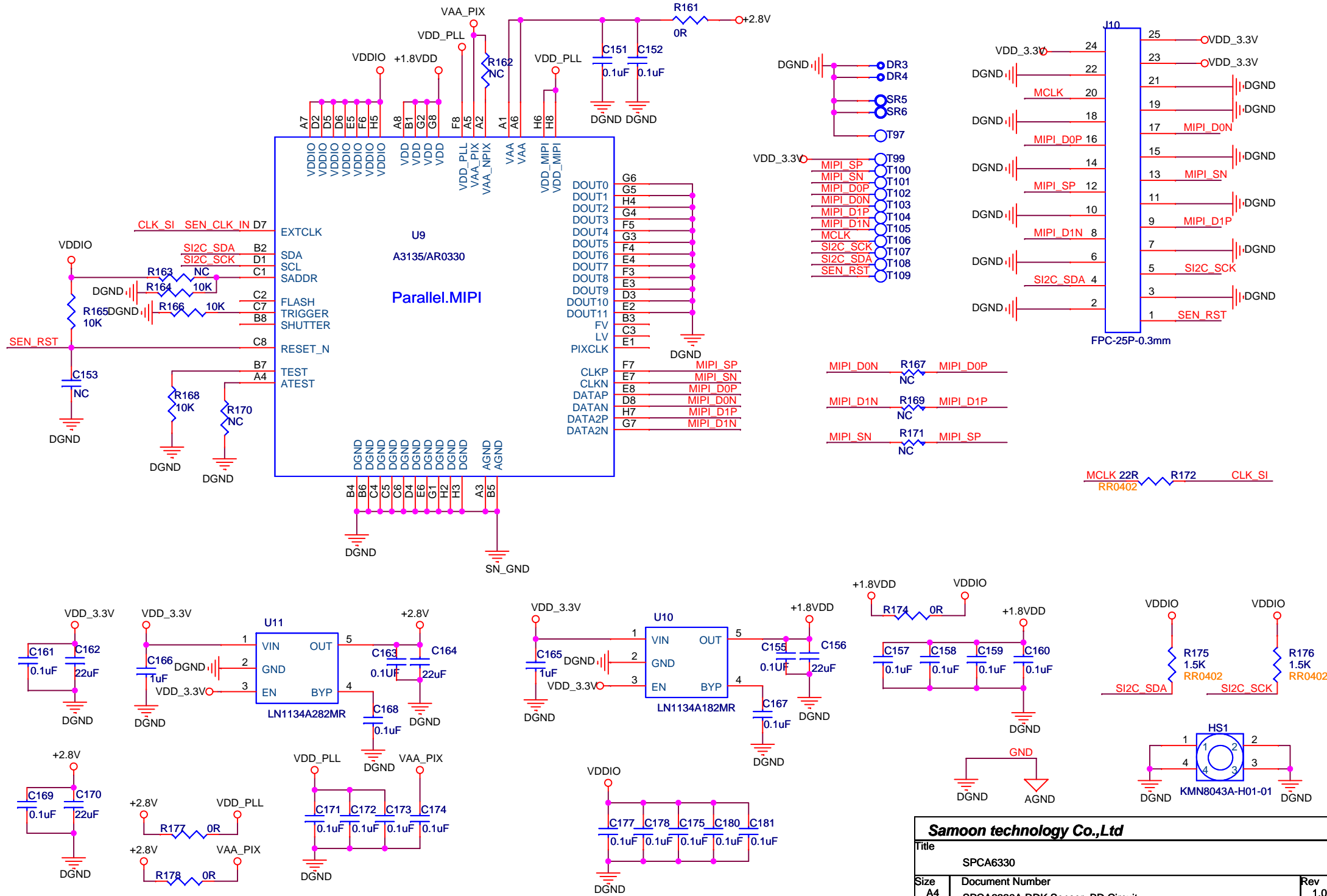

<b>Samoon technology Co.,Ltd</b>		
Title SPCA6330		
Size A4	Document Number SPCA6330A RDK Sensor_BD Circuit	Rev 1.0
Date: Thursday, May 23, 2013	Sheet 11	of 12

**Power ON Sequence :** 1) CH1 5V ON, 2) CH2 3V3 ON, 3) CH3 1V5 ON, 4) CH4 1V0 ON.  
**Power OFF Sequence :** 1) CH4 1V0 OFF, 2) CH3 1V5 OFF, 3) CH2 3V3 OFF, 4) CH1 5V OFF.

1080p30录像实测电流	
VCC_1V8	45mA
3.0VA	30mA
+3.3VD	200mA
1.0VD	450mA
1.5V	100mA

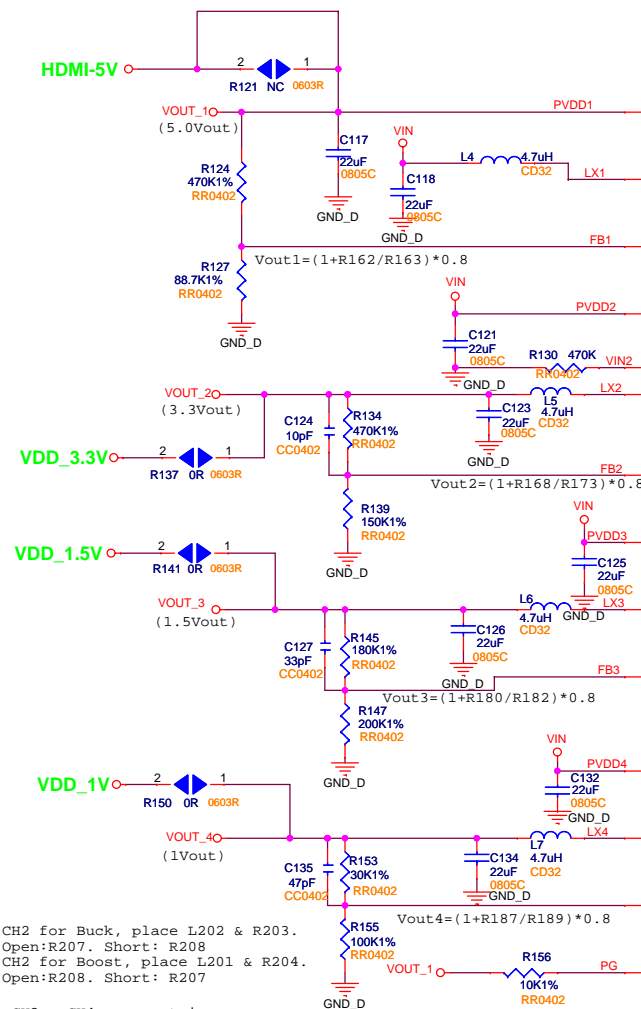

CH2 for Buck, place L202 & R203.  
 Open:R207. Short: R208.  
 CH2 for Boost, place L201 & R204.  
 Open:R208. Short: R207.

CH3 & CH4 compenstaion:  
 1V: R301=23.2Kohm, R302=93.1Kohm, C=47pF  
 1.2V: R301=187Kohm, R302=374Kohm, C=82pF  
 1.3V: R301=237Kohm, R302=374Kohm, C=68pF  
 1.8V: R301=470Kohm, R302=374Kohm, C=33pF  
 2.5V: R301=768Kohm, R302=360Kohm, C=22pF

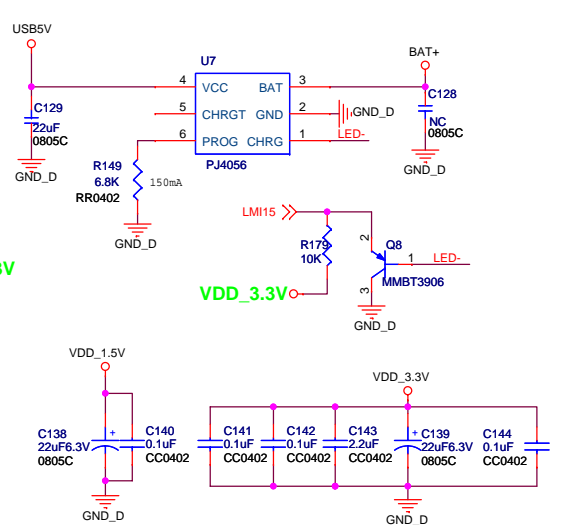
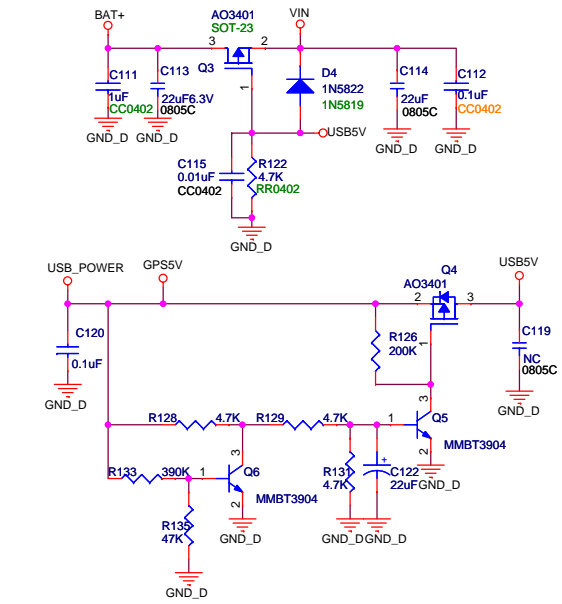
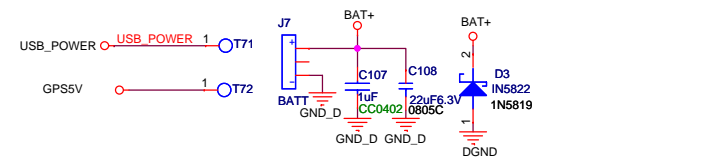
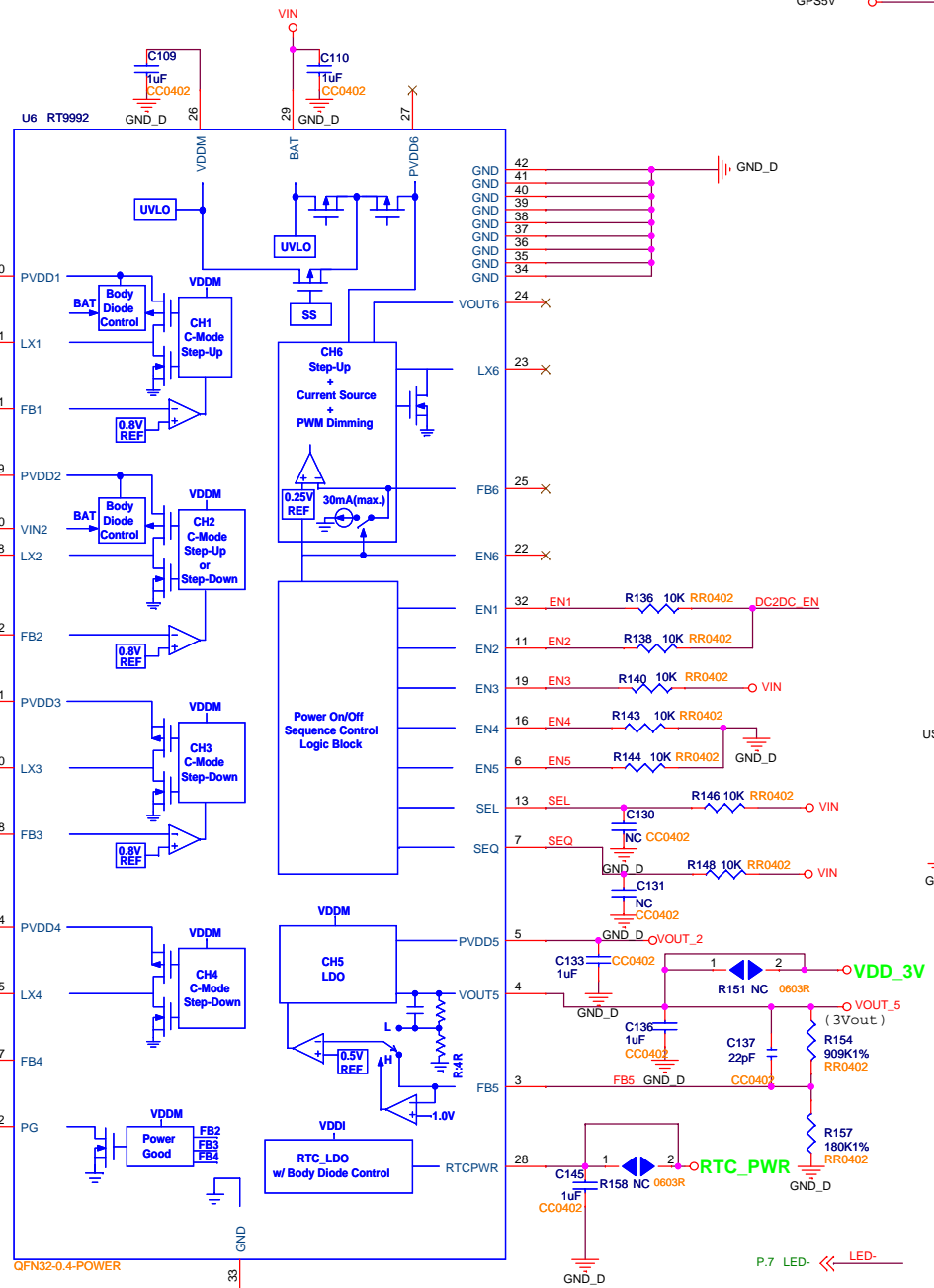

Samoon technology Co.,Ltd		
Title	SPCA6330	
Size	Document Number	Rev
A3	SPCA6330A RDK POWER Circuit	1.0
Date:	Saturday, June 29, 2013	Sheet 9 of 12



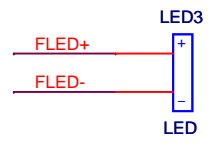
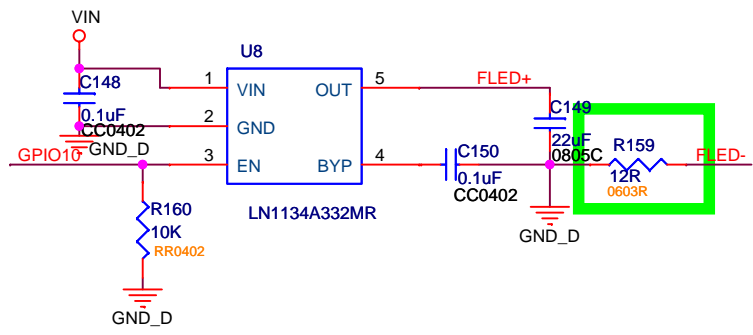
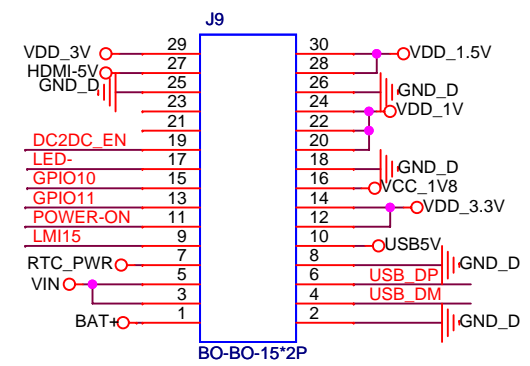
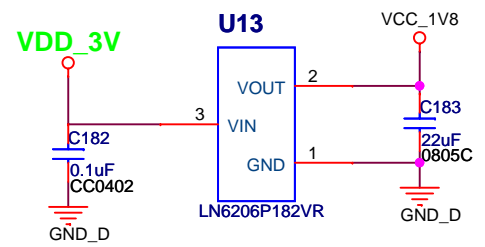
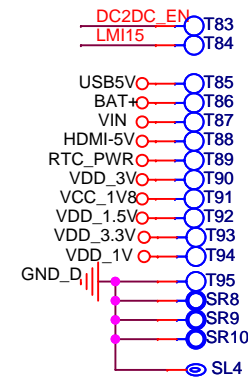
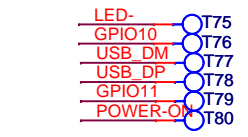
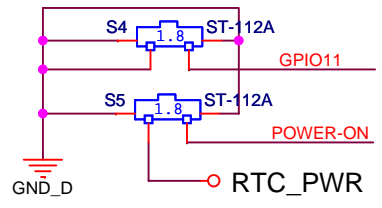
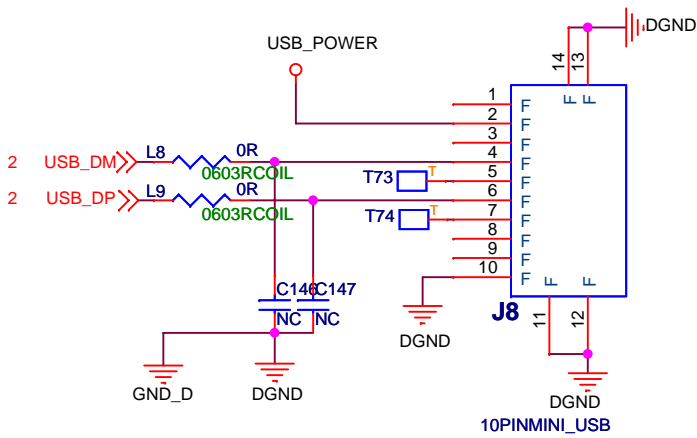

<b>Samoon technology Co.,Ltd</b>		
Title SPCA6330		
Size A4	Document Number SPCA6330A WIFI Circuit	Rev 1.0
Date: Thursday, May 23, 2013	Sheet 10	of 12

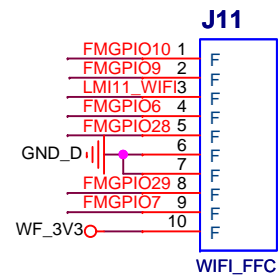
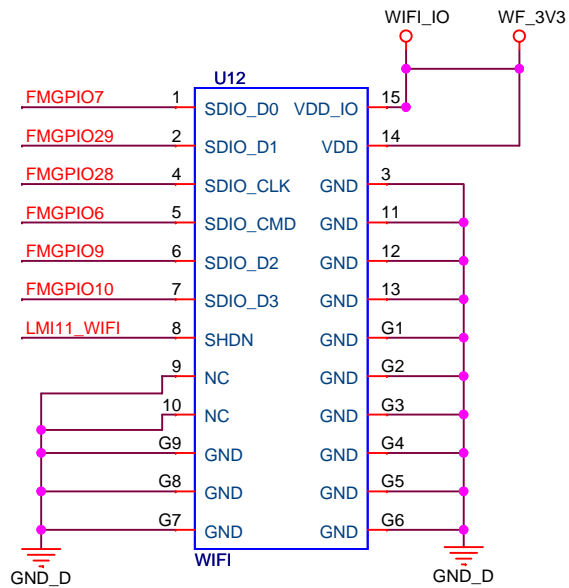

<b>Samoon technology Co.,Ltd</b>		
Title		
SPCA6330		
Size	Document Number	Rev
A4	SPCA6330A WIFI MODULE	1.0
Date:	Tuesday, July 09, 2013	Sheet 12 of 12