

FCC Test Report

FCC ID : 2AAS9-BW1257
Equipment : Tri-Band Wi-Fi AC3000 Indoor Access Point
Model No. : BW1257
Brand Name : BROWAN
Applicant : BROWAN COMMUNICATIONS Co., Ltd.
Address : No.15-1, Zhoughua Rd, Hsinchu Industrial Park, Hukou, Hsinchu, Taiwan, R.O.C. 333
Standard : 47 CFR FCC Part 15.247
Received Date : Dec. 18, 2018
Tested Date : Dec. 24 ~ Apr. 03, 2019

We, International Certification Corp., would like to declare that the tested sample has been evaluated and in compliance with the requirement of the above standards. The test results contained in this report refer exclusively to the product. It may be duplicated completely for legal use with the approval of the applicant. It shall not be reproduced except in full without the written approval of our laboratory.

Reviewed by:

Along Chen / Assistant Manager

Approved by:

Gary Chang / Manager



Table of Contents

1	GENERAL DESCRIPTION	5
1.1	Information.....	5
1.2	Local Support Equipment List	8
1.3	Test Setup Chart	8
1.4	The Equipment List	12
1.5	Test Standards	14
1.6	Deviation from Test Standard and Measurement Procedure.....	14
1.7	Measurement Uncertainty	14
2	TEST CONFIGURATION.....	15
2.1	Testing Condition	15
2.2	The Worst Test Modes and Channel Details	15
3	TRANSMITTER TEST RESULTS	17
3.1	Conducted Emissions.....	17
3.2	6dB and Occupied Bandwidth	26
3.3	RF Output Power.....	35
3.4	Power Spectral Density	38
3.5	Unwanted Emissions into Restricted Frequency Bands	47
3.6	Emissions in Non-Restricted Frequency Bands.....	93
4	TEST LABORATORY INFORMATION	100

Release Record

Report No.	Version	Description	Issued Date
FR8D1801AC	Rev. 01	Initial issue	Jun. 19, 2019

Summary of Test Results

FCC Rules	Test Items	Measured	Result
15.207	Conducted Emissions	[dBuV]: 19.435MHz 45.09 (Margin -4.91dB) - AV	Pass
15.247(d) 15.209	Radiated Emissions	[dBuV/m at 3m]: 2483.50MHz 52.97 (Margin -1.03dB) - AV	Pass
15.247(b)(3)	Maximum Output Power	Max Power [dBm]: Non-beamforming mode 28.22 Beamforming mode 21.29	Pass
15.247(a)(2)	6dB Bandwidth	Meet the requirement of limit	Pass
15.247(e)	Power Spectral Density	Meet the requirement of limit	Pass
15.203	Antenna Requirement	Meet the requirement of limit	Pass

Declaration of Conformity:

The test results with all measurement uncertainty excluded are presented in accordance with the regulation limits or requirements declared by manufacturers.

Comments and Explanations:

The declared values of gain for EUT presented in the report are provided by the manufacturer, and the manufacturer takes all the responsibilities for the accuracy of the gain.

1 General Description

1.1 Information

1.1.1 Specification of the Equipment under Test (EUT)

RF General Information					
Frequency Range (MHz)	IEEE Std. 802.11	Ch. Freq. (MHz)	Channel Number	Transmit Chains (N _{TX})	Data Rate / MCS
2400-2483.5	b	2412-2462	1-11 [11]	2	1-11 Mbps
2400-2483.5	g	2412-2462	1-11 [11]	2	6-54 Mbps
2400-2483.5	n (HT20)	2412-2462	1-11 [11]	2	MCS 0-15
2400-2483.5	n (HT40)	2422-2452	3-9 [7]	2	MCS 0-15

Note 1: RF output power specifies that Maximum Conducted (Average) Output Power.
 Note 2: 802.11b uses a combination of DSSS-DBPSK, DQPSK, CCK modulation.
 Note 3: 802.11g/n uses a combination of OFDM-BPSK, QPSK, 16QAM, 64QAM, 256QAM modulation..
 Note 4: 802.11n supports beamforming function.

1.1.2 Antenna Details

Ant. No.	Type	Connector	Operating Frequencies (MHz) / Antenna Gain (dBi)		
			2400~2483.5	5150~5250	5725~5850
1	Dipole	R-SMA	3.4	3.3	4.3
2	Dipole	R-SMA	2.8	2.7	3.4

Note: The antenna with highest gain was selected for final testing in this test report.

1.1.3 Power Supply Type of Equipment under Test (EUT)

Power Supply Type	12Vdc from adapter 55Vdc from POE
--------------------------	--------------------------------------

Note: The POE power supplies are not bundled in market.

1.1.4 Accessories

Accessories		
No.	Equipment	Description
1	Adapter	Brand: APD Model: WA-36A12FU Power Rating: I/P: 100-240Vac, 50-60Hz, 0.9A Max O/P: 12Vdc, 3A Power Line: 1.2m non-shielded without core
2	RJ45 (EEKSONG)	1.95m non-shielded without core
3	Core	Brand: King core Mode:KCF-130

1.1.5 Channel List

Frequency band (MHz)		2400~2483.5	
802.11 b / g / n HT20		802.11n HT40	
Channel	Frequency(MHz)	Channel	Frequency(MHz)
1	2412	3	2422
2	2417	4	2427
3	2422	5	2432
4	2427	6	2437
5	2432	7	2442
6	2437	8	2447
7	2442	9	2452
8	2447	---	---
9	2452	---	---
10	2457	---	---
11	2462	---	---

1.1.6 Test Tool and Duty Cycle

Test Tool	Non-beamforming: QRCT, V3.0.298.0 Beamforming: LanTest, V2.0.0.2				
Duty Cycle and Duty Factor	Mode	Non-beamforming		Beamforming	
		Duty cycle (%)	Duty factor (dB)	Duty cycle (%)	Duty factor (dB)
	11b	100.00%	0.00	---	---
	11g	96.52%	0.15	---	---
	HT20	98.74%	0.06	92.45%	0.34
HT40	97.77%	0.10	86.44%	0.63	

1.1.7 Power Index of Test Tool

Modulation Mode	Test Frequency (MHz)	Power Index	
		Non-beamforming	Beamforming
11b	2412	23.5	---
11b	2437	26	---
11b	2462	22.5	---
11g	2412	17.5	---
11g	2437	24.5	---
11g	2462	16.5	---
HT20	2412	16.5	18
HT20	2437	24.5	21
HT20	2462	16	18
HT40	2422	13	15
HT40	2437	19	19
HT40	2452	12.5	15

1.2 Local Support Equipment List

Support Equipment List					
No.	Equipment	Brand	Model	FCC ID	Remarks
1	Notebook	Latitude E5470	R33002	DoC	---
2	Notebook	Latitude E6430	R33002	DoC	---
3	USB Flash	Kingston	DTSE9	---	---
4	Tri-Band Wi-Fi AC3000 Indoor Access Point	Browan	BW1257	---	Provided by applicant.

1.3 Test Setup Chart

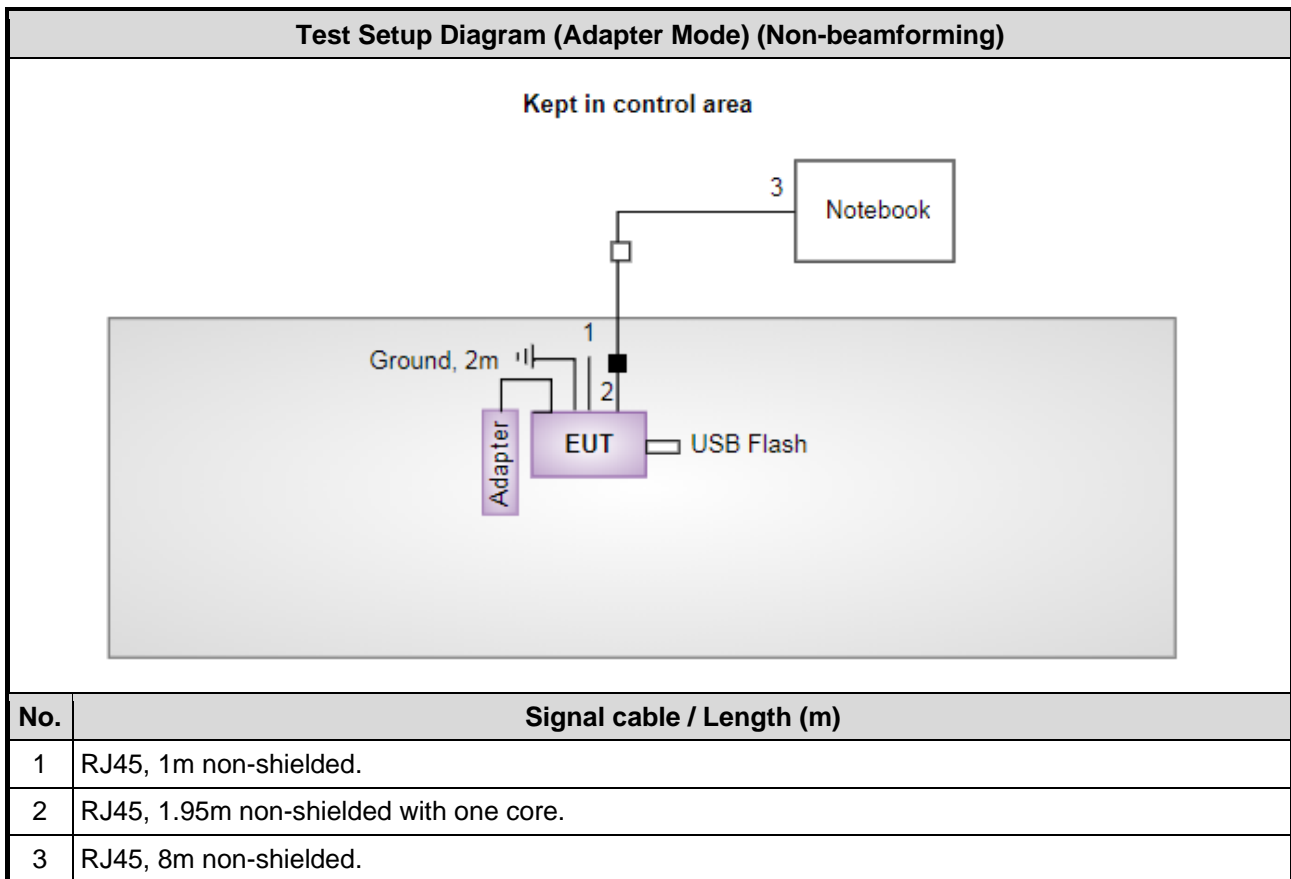

Test Setup Diagram (POE Mode) (Non-beamforming)

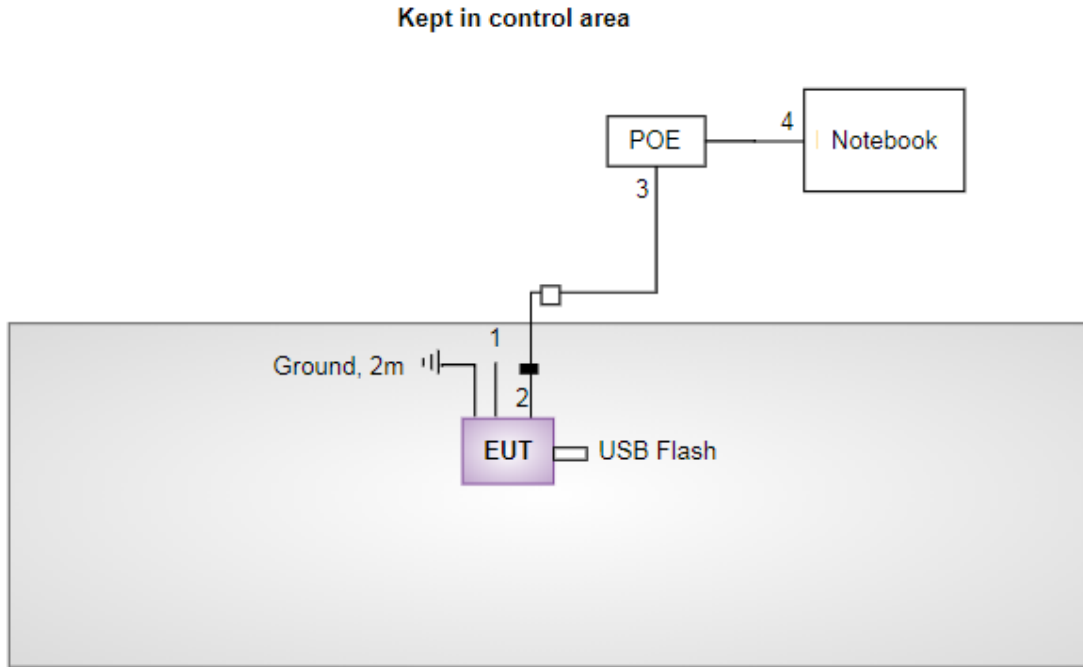

No.	Signal cable / Length (m)
1	RJ45, 1m non-shielded.
2	RJ45, 1.95m non-shielded with one core.
3	RJ45, 8m non-shielded.
4	RJ45, 1m non-shielded.

Test Setup Diagram (Adapter Mode) (Beamforming)

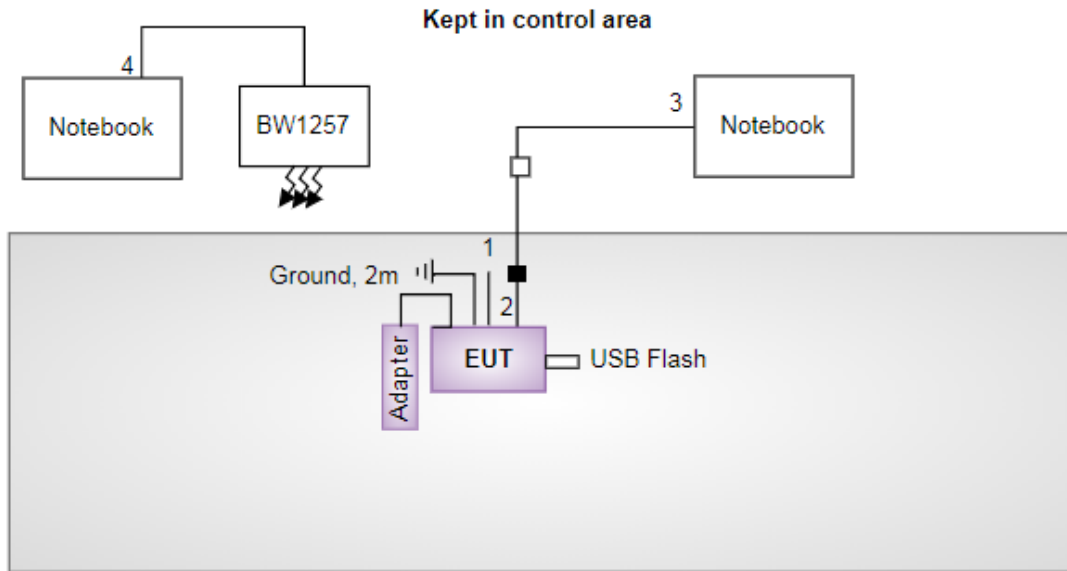

No.	Signal cable / Length (m)
1	RJ45, 1m non-shielded.
2	RJ45, 1.95m non-shielded with one core.
3	RJ45, 8m non-shielded.
4	RJ45, 1m non-shielded.

Test Setup Diagram (POE Mode) (Beamforming)

Kept in control area

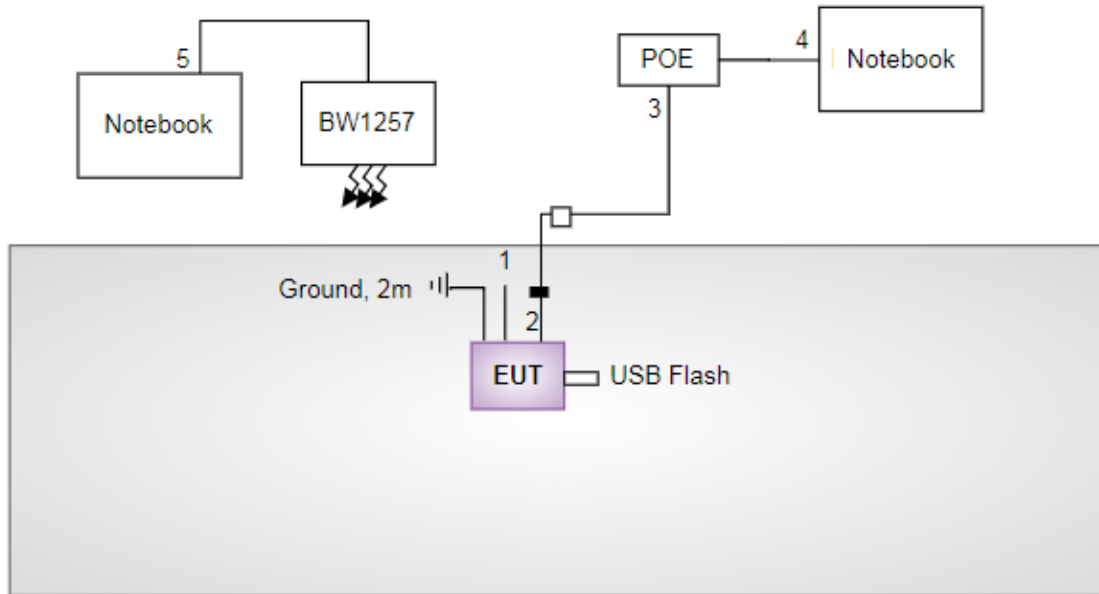

No.	Signal cable / Length (m)
1	RJ45, 1m non-shielded.
2	RJ45, 1.95m non-shielded with one core.
3	RJ45, 8m non-shielded.
4-5	RJ45, 1m non-shielded.

1.4 The Equipment List

Test Item	Conducted Emission				
Test Site	Conduction room 1 / (CO01-WS)				
Tested Date	Mar. 19, 2019				
Instrument	Manufacturer	Model No.	Serial No.	Calibration Date	Calibration Until
Receiver	R&S	ESR3	101657	Jan. 08, 2019	Jan. 07, 2020
LISN	R&S	ENV216	101579	Mar. 08, 2019	Mar. 07, 2020
RF Cable-CON	Woken	CFD200-NL	CFD200-NL-001	Oct. 23, 2018	Oct. 23, 2019
Measurement Software	AUDIX	e3	6.120210k	NA	NA
Note: Calibration Interval of instruments listed above is one year.					

Test Item	Radiated Emission				
Test Site	966 chamber 3 / (03CH03-WS)				
Tested Date	Mar. 19, 2019				
Instrument	Manufacturer	Model No.	Serial No.	Calibration Date	Calibration Until
Spectrum Analyzer	R&S	FSV40	101499	Jan. 07, 2019	Jan. 06, 2020
Receiver	R&S	ESR3	101658	Dec. 11, 2018	Dec. 10, 2019
Bilog Antenna	SCHWARZBECK	VULB9168	VULB9168-685	Apr. 19, 2018	Apr. 18, 2019
Horn Antenna 1G-18G	SCHWARZBECK	BBHA 9120 D	BBHA 9120 D 1206	Jan. 07, 2019	Jan. 06, 2020
Horn Antenna 18G-40G	SCHWARZBECK	BBHA 9170	BBHA 9170517	Nov. 15, 2018	Nov. 14, 2019
Loop Antenna	R&S	HFH2-Z2	100330	Nov. 09, 2018	Nov. 08, 2019
Loop Antenna Cable	KOAX KABEL	101354-BW	101354-BW	Oct. 08, 2018	Oct. 07, 2019
Preamplifier	EMC	EMC02325	980187	Aug. 24, 2018	Aug. 23, 2019
Preamplifier	Agilent	83017A	MY53270014	Aug. 09, 2018	Aug. 08, 2019
Preamplifier	EMC	EMC184045B	980192	Aug. 09, 2018	Aug. 08, 2019
RF cable-3M	HUBER+SUHNER	SUCOFLEX104	MY22620/4	Oct. 01, 2018	Sep. 30, 2019
RF cable-8M	EMC	EMC104-SM-SM-8000	181107	Oct. 01, 2018	Sep. 30, 2019
RF cable-1M	HUBER+SUHNER	SUCOFLEX104	MY22624/4	Oct. 01, 2018	Sep. 30, 2019
LF cable-0.8M	EMC	EMC8D-NM-NM-800	EMC8D-NM-NM-800-001	Oct. 01, 2018	Sep. 30, 2019
LF cable-3M	EMC	EMC8D-NM-NM-3000	131103	Oct. 01, 2018	Sep. 30, 2019
LF cable-13M	EMC	EMC8D-NM-NM-13000	131104	Oct. 01, 2018	Sep. 30, 2019
Measurement Software	AUDIX	e3	6.120210g	NA	NA
Note: Calibration Interval of instruments listed above is one year.					

Test Item	Radiated Emission				
Test Site	966 chamber 3 / (03CH03-WS)				
Tested Date	Dec. 24, 2018				
Instrument	Manufacturer	Model No.	Serial No.	Calibration Date	Calibration Until
Spectrum Analyzer	R&S	FSV40	101499	Jan. 03, 2018	Jan. 02, 2019
Receiver	R&S	ESR3	101658	Dec. 11, 2018	Dec. 10, 2019
Bilog Antenna	SCHWARZBECK	VULB9168	VULB9168-685	Apr. 19, 2018	Apr. 18, 2019
Horn Antenna 1G-18G	SCHWARZBECK	BBHA 9120 D	BBHA 9120 D 1206	Jan. 18, 2018	Jan. 17, 2019
Horn Antenna 18G-40G	SCHWARZBECK	BBHA 9170	BBHA 9170517	Nov. 15, 2018	Nov. 14, 2019
Loop Antenna	R&S	HFH2-Z2	100330	Nov. 09, 2018	Nov. 08, 2019
Loop Antenna Cable	KOAX KABEL	101354-BW	101354-BW	Oct. 08, 2018	Oct. 07, 2019
Preamplifier	EMC	EMC02325	980187	Aug. 24, 2018	Aug. 23, 2019
Preamplifier	Agilent	83017A	MY53270014	Aug. 09, 2018	Aug. 08, 2019
Preamplifier	EMC	EMC184045B	980192	Aug. 09, 2018	Aug. 08, 2019
RF cable-3M	HUBER+SUHNER	SUCOFLEX104	MY22620/4	Oct. 01, 2018	Sep. 30, 2019
RF cable-8M	EMC	EMC104-SM-SM-80 00	181107	Oct. 01, 2018	Sep. 30, 2019
RF cable-1M	HUBER+SUHNER	SUCOFLEX104	MY22624/4	Oct. 01, 2018	Sep. 30, 2019
LF cable-0.8M	EMC	EMC8D-NM-NM-800	EMC8D-NM-NM-800 -001	Oct. 01, 2018	Sep. 30, 2019
LF cable-3M	EMC	EMC8D-NM-NM-300 0	131103	Oct. 01, 2018	Sep. 30, 2019
LF cable-13M	EMC	EMC8D-NM-NM-130 00	131104	Oct. 01, 2018	Sep. 30, 2019
Measurement Software	AUDIX	e3	6.120210g	NA	NA
Note: Calibration Interval of instruments listed above is one year.					

Test Item	RF Conducted				
Test Site	(TH01-WS)				
Tested Date	Apr. 02 ~ Apr. 03, 2019				
Instrument	Manufacturer	Model No.	Serial No.	Calibration Date	Calibration Until
Spectrum Analyzer	R&S	FSV40	101063	Apr. 16, 2018	Apr. 15, 2019
Power Meter	Anritsu	ML2495A	1241002	Oct. 09, 2018	Oct. 08, 2019
Power Sensor	Anritsu	MA2411B	1207366	Oct. 09, 2018	Oct. 08, 2019
DC POWER SOURCE	GW INSTEK	GPC-6030D	EM892433	Oct. 25, 2018	Oct. 24, 2019
AC POWER SOURCE	APC	AFC-500W	F312060012	Nov. 29, 2018	Nov. 28, 2019
Measurement Software	Sporton	SENSE-15247_DTS	V5.9	NA	NA
Note: Calibration Interval of instruments listed above is one year.					

1.5 Test Standards

According to the specification of EUT, the EUT must comply with following standards and KDB documents.

47 CFR FCC Part 15.247

ANSI C63.10-2013

FCC KDB 558074 D01 15.247 Meas Guidance v05r02

FCC KDB 662911 D01 Multiple Transmitter Output v02r01

1.6 Deviation from Test Standard and Measurement Procedure

None

1.7 Measurement Uncertainty

ISO/IEC 17025 requires that an estimate of the measurement uncertainties associated with the emissions test results be included in the report. The measurement uncertainties given below are based on a 95% confidence level (based on a coverage factor (k=2))

Measurement Uncertainty	
Parameters	Uncertainty
Bandwidth	±34.130 Hz
Conducted power	±0.808 dB
Power density	±0.583 dB
Conducted emission	±2.715 dB
AC conducted emission	±2.92 dB
Radiated emission ≤ 1GHz	±3.96 dB
Radiated emission > 1GHz	±4.51 dB

2 Test Configuration

2.1 Testing Condition

Test Item	Test Site	Ambient Condition	Tested By
AC Conduction	CO01-WS	21°C / 62%	Akun Chung
Radiated Emissions	03CH03-WS	24°C / 61-65%	Roger Lu Akun Chung
RF Conducted	TH01-WS	21°C / 64%	Roger Lu

- FCC Designation No.: TW0009
- FCC site registration No.: 207696
- ISED#: 10807A
- CAB identifier: TW2732

2.2 The Worst Test Modes and Channel Details

Non-beamforming mode

Test item	Modulation Mode	Test Frequency (MHz)	Data Rate	Test Configuration
Conducted Emissions	11b	2437	1 Mbps	1, 2
Radiated Emissions ≤1GHz	11b	2437	1 Mbps	1, 2
Radiated Emissions >1GHz	11b 11g HT20 HT40	2412 / 2437 / 2462 2412 / 2437 / 2462 2412 / 2437 / 2462 2422 / 2437 / 2452	1 Mbps 6 Mbps MCS 0 MCS 0	2
Maximum Output Power 6dB bandwidth Power spectral density	11b 11g HT20 HT40	2412 / 2437 / 2462 2412 / 2437 / 2462 2412 / 2437 / 2462 2422 / 2437 / 2452	1 Mbps 6 Mbps MCS 0 MCS 0	1

NOTE:

1. The EUT was pretested with 3 orientations placed on the table for the radiated emission measurement – X, Y, and Z-plane. The **X-plane** results were found as the worst case and were shown in this report.
2. The EUT had been tested by following test configurations.
 - 1) Configuration 1 : Adapter mode
 - 2) Configuration 2 : POE mode

Beamforming mode

Test item	Modulation Mode	Test Frequency (MHz)	Data Rate	Test Configuration
Conducted Emissions	HT20	2437	MCS 0	1, 2
Radiated Emissions ≤ 1 GHz	HT20	2437	MCS 0	1, 2
Radiated Emissions > 1 GHz	HT20 HT40	2412 / 2437 / 2462 2422 / 2437 / 2452	MCS 0 MCS 0	2
Maximum Output Power 6dB bandwidth Power spectral density	HT20 HT40	2412 / 2437 / 2462 2422 / 2437 / 2452	MCS 0 MCS 0	1

NOTE:

1. The EUT was pretested with 3 orientations placed on the table for the radiated emission measurement – X, Y, and Z-plane. The **X-plane** results were found as the worst case and were shown in this report.
2. The EUT had been tested by following test configurations.
 - 3) Configuration 1 : Adapter mode
 - 4) Configuration 2 : POE mode

3 Transmitter Test Results

3.1 Conducted Emissions

3.1.1 Limit of Conducted Emissions

Conducted Emissions Limit		
Frequency Emission (MHz)	Quasi-Peak	Average
0.15-0.5	66 - 56 *	56 - 46 *
0.5-5	56	46
5-30	60	50

Note 1: * Decreases with the logarithm of the frequency.

3.1.2 Test Procedures

1. The device is placed on a test table, raised 80 cm above the reference ground plane. The vertical conducting plane is located 40 cm to the rear of the device.
2. The device is connected to line impedance stabilization network (LISN) and other accessories are connected to other LISN. Measured levels of AC power line conducted emission are across the 50 Ω LISN port.
3. AC conducted emission measurements is made over frequency range from 150 kHz to 30 MHz.
4. This measurement was performed with AC 120V / 60Hz.

3.1.3 Test Setup

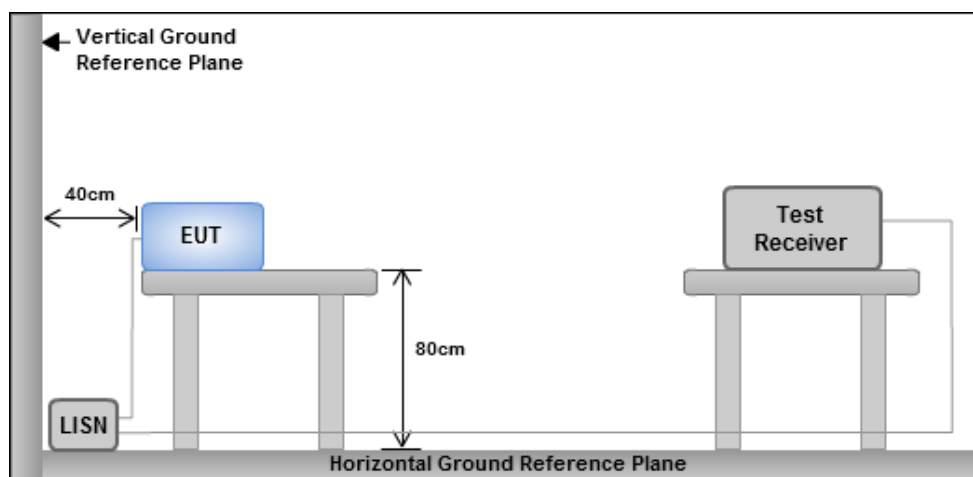

Note: 1. Support units were connected to second LISN.

2. Both of LISNs (AMN) are 80 cm from EUT and at least 80 cm from other units and other metal planes

3.1.4 Test Result of Conducted Emissions

Non-beamforming mode

Modulation	11b	Test Freq. (MHz)	2437
Power Phase	Line	Test Configuration	1

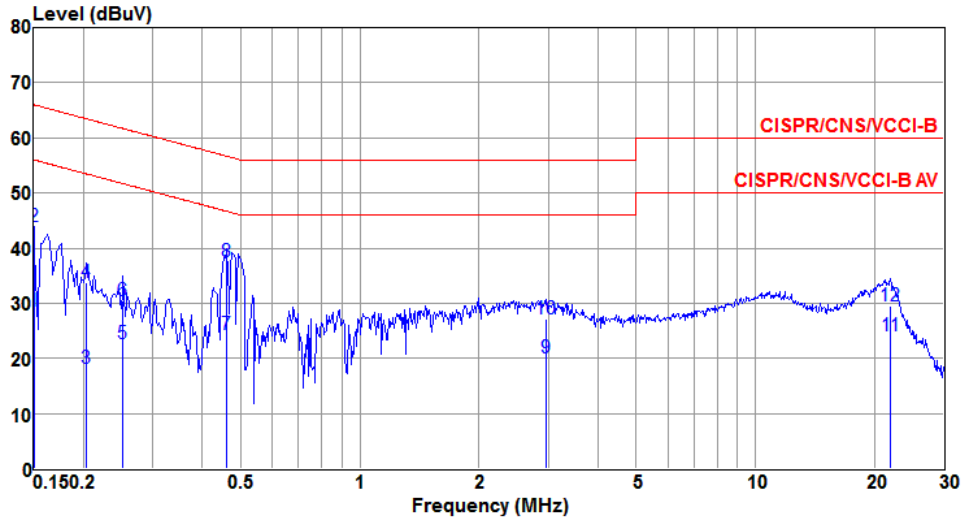

	Freq MHz	Level dBuV	Limit Line dBuV	Over Limit dB	Read Level dBuV	LISN factor dB	cable loss dB	Remark
1	0.150	28.63	56.00	-27.37	28.39	0.07	0.05	Average
2	0.150	43.79	66.00	-22.21	43.55	0.07	0.05	QP
3	0.204	18.07	53.45	-35.38	17.75	0.06	0.07	Average
4	0.204	33.78	63.45	-29.67	33.46	0.06	0.07	QP
5	0.252	22.58	51.69	-29.11	22.24	0.06	0.07	Average
6	0.252	30.50	61.69	-31.19	30.16	0.06	0.07	QP
7	0.461	24.22	46.67	-22.45	23.81	0.06	0.08	Average
8*	0.461	37.48	56.67	-19.19	37.07	0.06	0.08	QP
9	2.962	20.01	46.00	-25.99	19.31	0.10	0.23	Average
10	2.962	27.15	56.00	-28.85	26.45	0.10	0.23	QP
11	21.946	23.99	50.00	-26.01	22.47	0.25	0.63	Average
12	21.946	29.41	60.00	-30.59	27.89	0.25	0.63	QP

Note 1: Level (dBuV) = Read Level (dBuV) + LISN Factor (dB) + Cable Loss (dB).
 2: Over Limit (dB) = Level (dBuV) – Limit Line (dBuV).

Modulation	11b	Test Freq. (MHz)	2437
Power Phase	Neutral	Test Configuration	1

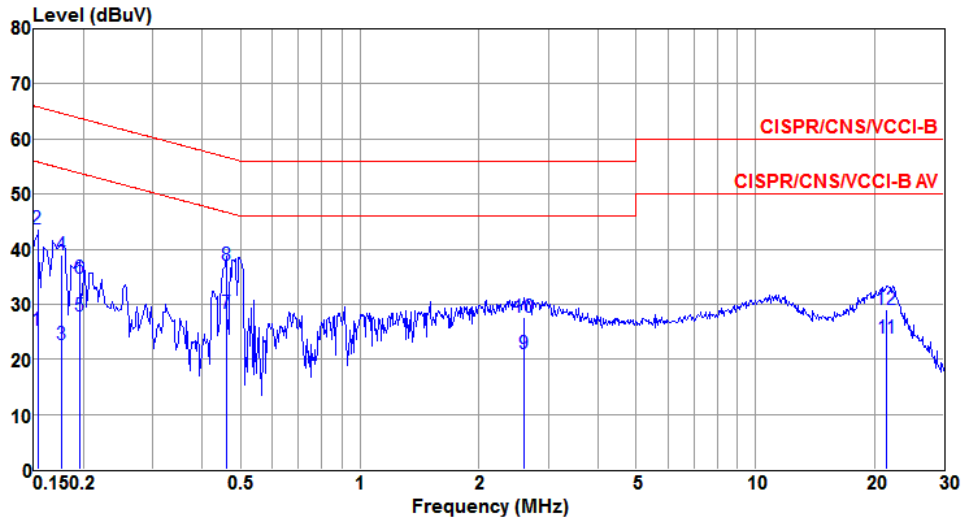

	Freq MHz	Level dBuV	Limit Line dBuV	Over Limit dB	Read Level dBuV	LISN factor dB	cable loss dB	Remark
1	0.153	25.32	55.82	-30.50	25.11	0.05	0.05	Average
2	0.153	43.66	65.82	-22.16	43.45	0.05	0.05	QP
3	0.177	22.56	54.64	-32.08	22.33	0.04	0.06	Average
4	0.177	38.90	64.64	-25.74	38.67	0.04	0.06	QP
5	0.195	27.90	53.80	-25.90	27.65	0.04	0.07	Average
6	0.195	34.75	63.80	-29.05	34.50	0.04	0.07	QP
7*	0.459	28.29	46.71	-18.42	28.02	0.05	0.08	Average
8	0.459	37.13	56.71	-19.58	36.86	0.05	0.08	QP
9	2.608	21.04	46.00	-24.96	20.50	0.08	0.21	Average
10	2.608	27.70	56.00	-28.30	27.16	0.08	0.21	QP
11	21.486	23.73	50.00	-26.27	22.32	0.27	0.63	Average
12	21.486	29.05	60.00	-30.95	27.64	0.27	0.63	QP

Note 1: Level (dBuV) = Read Level (dBuV) + LISN Factor (dB) + Cable Loss (dB).
 2: Over Limit (dB) = Level (dBuV) – Limit Line (dBuV).

Modulation	11b	Test Freq. (MHz)	2437
Power Phase	Line	Test Configuration	2

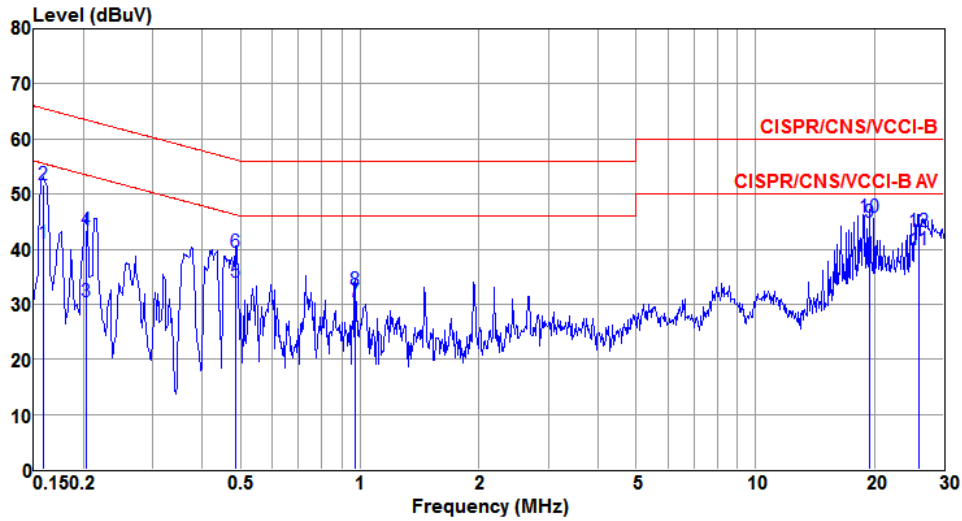

	Freq MHz	Level dBuV	Limit Line dBuV	Over Limit dB	Read Level dBuV	LISN factor dB	cable loss dB	Remark
1	0.159	41.01	55.52	-14.51	40.89	0.07	0.05	Average
2	0.159	51.68	65.52	-13.84	51.56	0.07	0.05	QP
3	0.204	30.42	53.45	-23.03	30.29	0.06	0.07	Average
4	0.204	43.51	63.45	-19.94	43.38	0.06	0.07	QP
5	0.484	34.02	46.27	-12.25	33.88	0.06	0.08	Average
6	0.484	39.35	56.27	-16.92	39.21	0.06	0.08	QP
7	0.974	30.46	46.00	-15.54	30.28	0.08	0.10	Average
8	0.974	32.58	56.00	-23.42	32.40	0.08	0.10	QP
9*	19.435	44.79	50.00	-5.21	43.95	0.24	0.60	Average
10	19.435	45.85	60.00	-14.15	45.01	0.24	0.60	QP
11	25.998	39.92	50.00	-10.08	38.95	0.27	0.70	Average
12	25.998	43.17	60.00	-16.83	42.20	0.27	0.70	QP

Note 1: Level (dBuV) = Read Level (dBuV) + LISN Factor (dB) + Cable Loss (dB).
 2: Over Limit (dB) = Level (dBuV) – Limit Line (dBuV).

Modulation	11b	Test Freq. (MHz)	2437
Power Phase	Neutral	Test Configuration	2

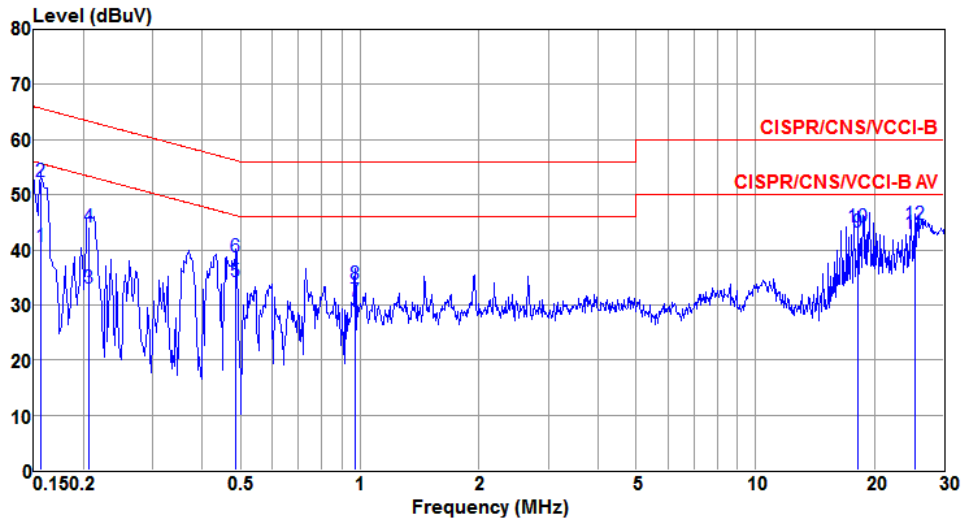

	Freq MHz	Level dBUV	Limit Line dBUV	Over Limit dB	Read Level dBUV	LISN factor dB	cable loss dB	Remark
1	0.156	40.63	55.69	-15.06	40.53	0.05	0.05	Average
2	0.156	52.35	65.69	-13.34	52.25	0.05	0.05	QP
3	0.207	33.03	53.32	-20.29	32.92	0.04	0.07	Average
4	0.207	44.12	63.32	-19.20	44.01	0.04	0.07	QP
5	0.486	34.29	46.23	-11.94	34.16	0.05	0.08	Average
6	0.486	38.70	56.23	-17.53	38.57	0.05	0.08	QP
7	0.974	30.63	46.00	-15.37	30.47	0.06	0.10	Average
8	0.974	33.65	56.00	-22.35	33.49	0.06	0.10	QP
9*	18.224	43.09	50.00	-6.91	42.25	0.25	0.59	Average
10	18.224	44.04	60.00	-15.96	43.20	0.25	0.59	QP
11	25.266	43.02	50.00	-6.98	42.03	0.30	0.69	Average
12	25.266	44.64	60.00	-15.36	43.65	0.30	0.69	QP

Note 1: Level (dBUV) = Read Level (dBUV) + LISN Factor (dB) + Cable Loss (dB).
 2: Over Limit (dB) = Level (dBUV) – Limit Line (dBUV).

Beamforming mode

Modulation	HT20	Test Freq. (MHz)	2437
Power Phase	Line	Test Configuration	1

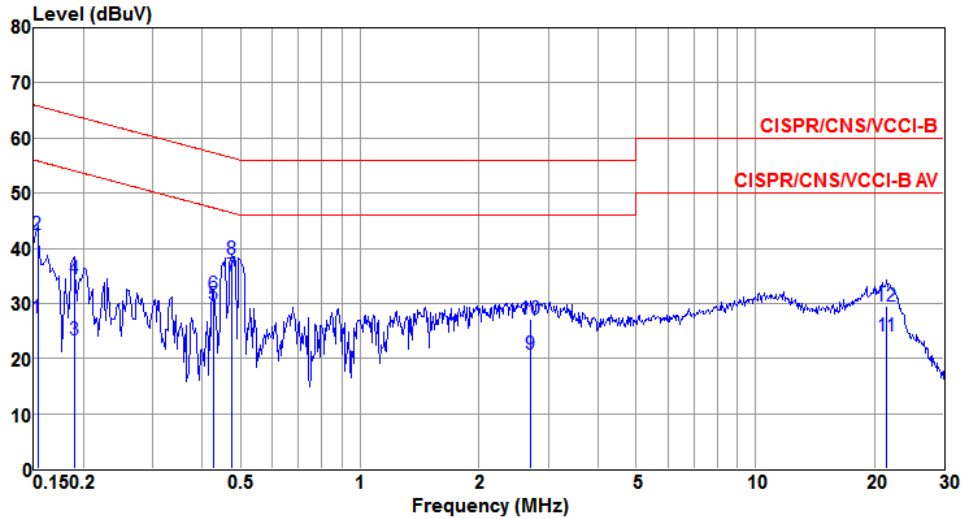

	Freq	Level	Limit	Over	Read	LISN	cable	
	MHz	dBuV	Line	Limit	Level	factor	loss	Remark
			dBuV	dB	dBuV	dB	dB	
1	0.153	27.44	55.82	-28.38	27.19	0.07	0.05	Average
2	0.153	42.37	65.82	-23.45	42.12	0.07	0.05	QP
3	0.189	23.42	54.06	-30.64	23.11	0.06	0.07	Average
4	0.189	34.56	64.06	-29.50	34.25	0.06	0.07	QP
5	0.426	29.75	47.33	-17.58	29.35	0.06	0.08	Average
6	0.426	31.72	57.33	-25.61	31.32	0.06	0.08	QP
7*	0.474	34.98	46.45	-11.47	34.57	0.06	0.08	Average
8	0.474	38.02	56.45	-18.43	37.61	0.06	0.08	QP
9	2.707	20.77	46.00	-25.23	20.09	0.10	0.21	Average
10	2.707	27.05	56.00	-28.95	26.37	0.10	0.21	QP
11	21.486	24.19	50.00	-25.81	22.67	0.25	0.63	Average
12	21.486	29.59	60.00	-30.41	28.07	0.25	0.63	QP

Note 1: Level (dBuV) = Read Level (dBuV) + LISN Factor (dB) + Cable Loss (dB).
 2: Over Limit (dB) = Level (dBuV) – Limit Line (dBuV).

Modulation	HT20	Test Freq. (MHz)	2437
Power Phase	Neutral	Test Configuration	1

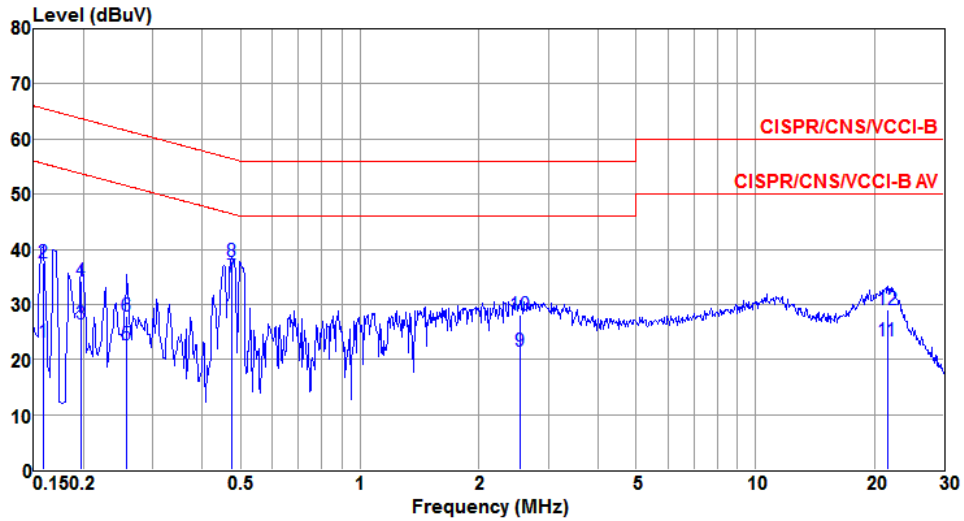

	Freq	Level	Limit	Over	Read	LISN	cable	Remark
	MHz	dBuV	Line	Limit	Level	factor	loss	
			dBuV	dB	dBuV	dB	dB	
1	0.159	23.20	55.52	-32.32	22.98	0.05	0.05	Average
2	0.159	37.60	65.52	-27.92	37.38	0.05	0.05	QP
3	0.198	26.51	53.71	-27.20	26.26	0.04	0.07	Average
4	0.198	34.23	63.71	-29.48	33.98	0.04	0.07	QP
5	0.258	22.58	51.51	-28.93	22.34	0.04	0.07	Average
6	0.258	27.91	61.51	-33.60	27.67	0.04	0.07	QP
7*	0.474	34.86	46.45	-11.59	34.59	0.05	0.08	Average
8	0.474	37.71	56.45	-18.74	37.44	0.05	0.08	QP
9	2.540	21.37	46.00	-24.63	20.84	0.08	0.20	Average
10	2.540	28.07	56.00	-27.93	27.54	0.08	0.20	QP
11	21.600	23.39	50.00	-26.61	21.97	0.27	0.63	Average
12	21.600	29.09	60.00	-30.91	27.67	0.27	0.63	QP

Note 1: Level (dBuV) = Read Level (dBuV) + LISN Factor (dB) + Cable Loss (dB).
 2: Over Limit (dB) = Level (dBuV) – Limit Line (dBuV).

Modulation	HT20	Test Freq. (MHz)	2437
Power Phase	Line	Test Configuration	2

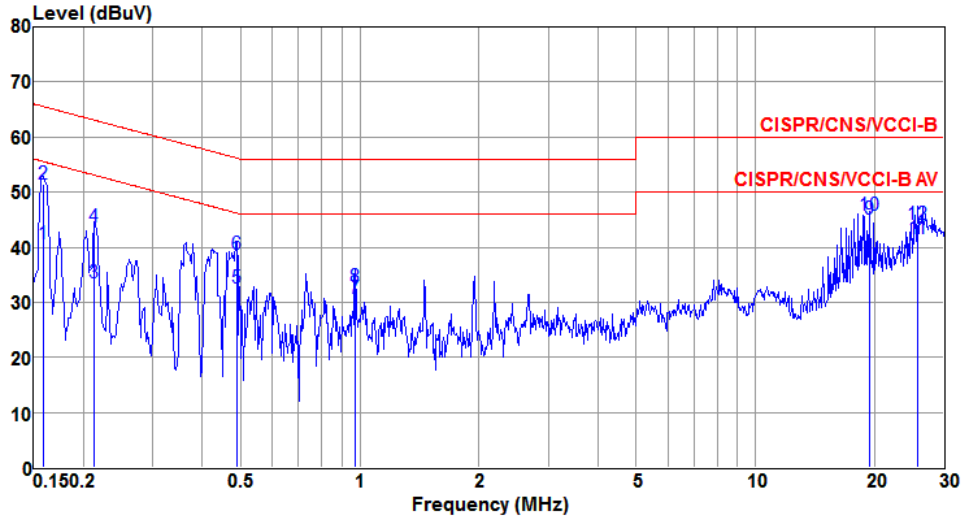

	Freq MHz	Level dBuV	Limit Line dBuV	Over Limit dB	Read Level dBuV	LISN factor dB	cable loss dB	Remark
1	0.159	40.64	55.52	-14.88	40.52	0.07	0.05	Average
2	0.159	51.37	65.52	-14.15	51.25	0.07	0.05	QP
3	0.213	33.63	53.10	-19.47	33.50	0.06	0.07	Average
4	0.213	43.66	63.10	-19.44	43.53	0.06	0.07	QP
5	0.489	32.53	46.19	-13.66	32.39	0.06	0.08	Average
6	0.489	38.66	56.19	-17.53	38.52	0.06	0.08	QP
7	0.974	30.61	46.00	-15.39	30.43	0.08	0.10	Average
8	0.974	32.82	56.00	-23.18	32.64	0.08	0.10	QP
9*	19.435	45.09	50.00	-4.91	44.25	0.24	0.60	Average
10	19.435	45.90	60.00	-14.10	45.06	0.24	0.60	QP
11	25.753	41.59	50.00	-8.41	40.63	0.26	0.70	Average
12	25.753	44.25	60.00	-15.75	43.29	0.26	0.70	QP

Note 1: Level (dBuV) = Read Level (dBuV) + LISN Factor (dB) + Cable Loss (dB).
 2: Over Limit (dB) = Level (dBuV) – Limit Line (dBuV).

Modulation	HT20	Test Freq. (MHz)	2437
Power Phase	Neutral	Test Configuration	2

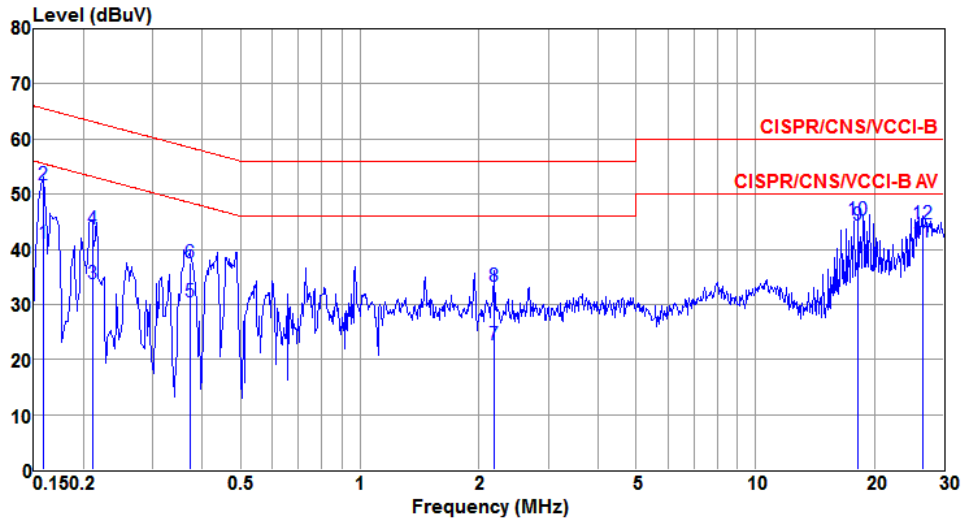

	Freq MHz	Level dBuV	Limit Line dBuV	Over Limit dB	Read Level dBuV	LISN factor dB	cable loss dB	Remark
1	0.159	41.02	55.52	-14.50	40.92	0.05	0.05	Average
2	0.159	51.59	65.52	-13.93	51.49	0.05	0.05	QP
3	0.211	33.66	53.18	-19.52	33.55	0.04	0.07	Average
4	0.211	43.72	63.18	-19.46	43.61	0.04	0.07	QP
5	0.371	30.47	48.47	-18.00	30.34	0.05	0.08	Average
6	0.371	37.63	58.47	-20.84	37.50	0.05	0.08	QP
7	2.178	22.67	46.00	-23.33	22.42	0.07	0.18	Average
8	2.178	33.32	56.00	-22.68	33.07	0.07	0.18	QP
9*	18.222	44.32	50.00	-5.68	43.48	0.25	0.59	Average
10	18.222	45.41	60.00	-14.59	44.57	0.25	0.59	QP
11	26.480	41.28	50.00	-8.72	40.25	0.31	0.72	Average
12	26.480	44.60	60.00	-15.40	43.57	0.31	0.72	QP

Note 1: Level (dBuV) = Read Level (dBuV) + LISN Factor (dB) + Cable Loss (dB).
 2: Over Limit (dB) = Level (dBuV) – Limit Line (dBuV).

3.2 6dB and Occupied Bandwidth

3.2.1 Limit of 6dB Bandwidth

The minimum 6dB bandwidth shall be at least 500 kHz.

3.2.2 Test Procedures

6dB Bandwidth

1. Set resolution bandwidth (RBW) = 100 kHz, Video bandwidth = 300 kHz.
2. Detector = Peak, Trace mode = max hold.
3. Sweep = auto couple, Allow the trace to stabilize.
4. Measure the maximum width of the emission that is constrained by the frequencies associated with the two outermost amplitude points (upper and lower) that are attenuated by 6dB relative to the maximum level measured in the fundamental emission.

Occupied Bandwidth

1. Set resolution bandwidth (RBW) = 1% ~ 5 % of OBW, Video bandwidth = 3 x RBW
2. Detector = Sample, Trace mode = max hold.
3. Sweep = auto couple, Allow the trace to stabilize.
4. Use the OBW measurement function of spectrum analyzer to measure the occupied bandwidth.

3.2.3 Test Setup

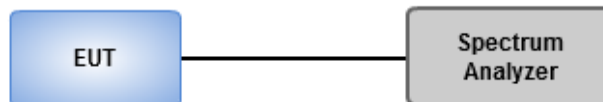

3.2.4 Test Result of 6dB and Occupied Bandwidth

Non-beamforming mode

Summary

Mode	Max-N dB (Hz)	Max-OBW (Hz)	ITU-Code	Min-N dB (Hz)	Min-OBW (Hz)
2.4-2.4835GHz	-	-	-	-	-
802.11b_Nss1,(1Mbps)_2T X	8.043M	13.821M	13M8G1D	7.609M	12.952M
802.11g_Nss1,(6Mbps)_2T X	16.377M	16.57M	16M6D1D	16.304M	16.425M
802.11n HT20_Nss1,(MCS0)_2TX	17.609M	17.728M	17M7D1D	16.739M	17.583M
802.11n HT40_Nss1,(MCS0)_2TX	35.072M	35.89M	35M9D1D	31.304M	35.745M

Max-N dB = Maximum6dB downbandwidth;**Max-OBW** = Maximum99% occupied bandwidth;
Min-N dB = Minimum6dB downbandwidth;**Min-OBW** = Minimum99% occupied bandwidth;

Result

Mode	Result	Limit (Hz)	Port 1 -N dB (Hz)	Port 1 -OBW (Hz)	Port 2 -N dB (Hz)	Port 2 -OBW (Hz)
802.11b_Nss1,(1Mbps)_2TX	-	-	-	-	-	-
2412MHz	Pass	500k	8.043M	12.952M	8.043M	13.025M
2437MHz	Pass	500k	8.043M	13.531M	8.043M	13.821M
2462MHz	Pass	500k	7.609M	12.952M	8.043M	12.952M
802.11g_Nss1,(6Mbps)_2TX	-	-	-	-	-	-
2412MHz	Pass	500k	16.377M	16.425M	16.377M	16.425M
2437MHz	Pass	500k	16.304M	16.498M	16.304M	16.57M
2462MHz	Pass	500k	16.304M	16.425M	16.304M	16.425M
802.11n HT20_Nss1,(MCS0)_2TX	-	-	-	-	-	-
2412MHz	Pass	500k	17.609M	17.583M	17.536M	17.583M
2437MHz	Pass	500k	16.739M	17.728M	17.536M	17.728M
2462MHz	Pass	500k	17.609M	17.583M	17.609M	17.583M
802.11n HT40_Nss1,(MCS0)_2TX	-	-	-	-	-	-
2422MHz	Pass	500k	33.913M	35.89M	31.304M	35.745M
2437MHz	Pass	500k	35.072M	35.89M	35.072M	35.745M
2452MHz	Pass	500k	35.072M	35.89M	35.072M	35.89M

Port X-N dB = Port X6dB downbandwidth; **Port X-OBW** = Port X99% occupied bandwidth;

802.11b_Nss1,(1Mbps)_2TX

EBW

2412MHz

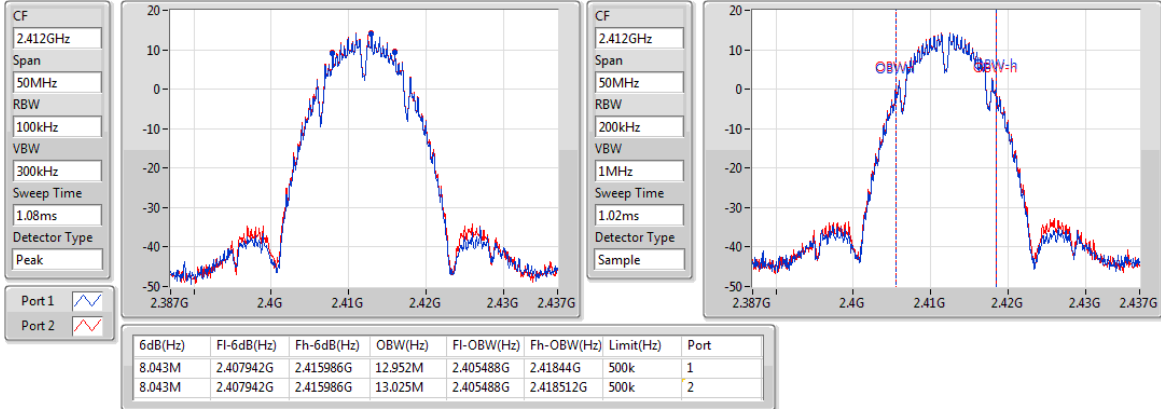

802.11b_Nss1,(1Mbps)_2TX

EBW

2437MHz

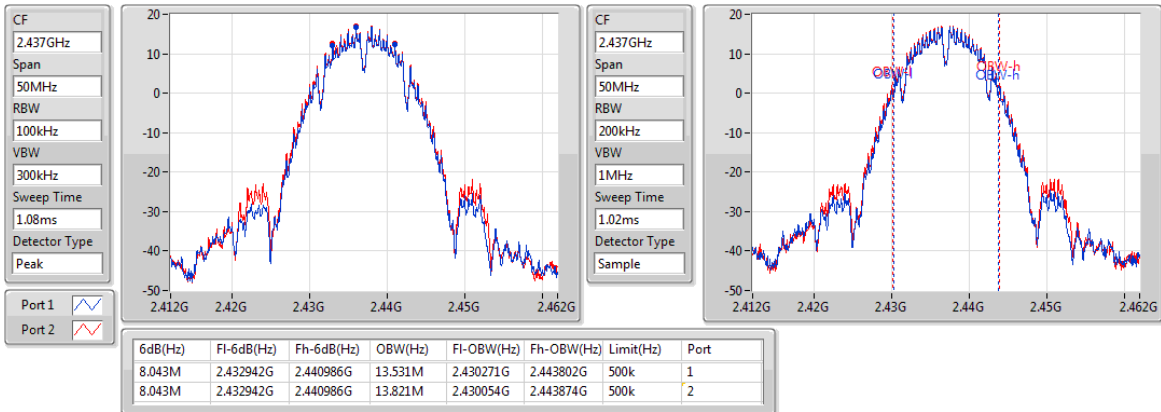

802.11b_Nss1,(1Mbps)_2TX

EBW

2462MHz

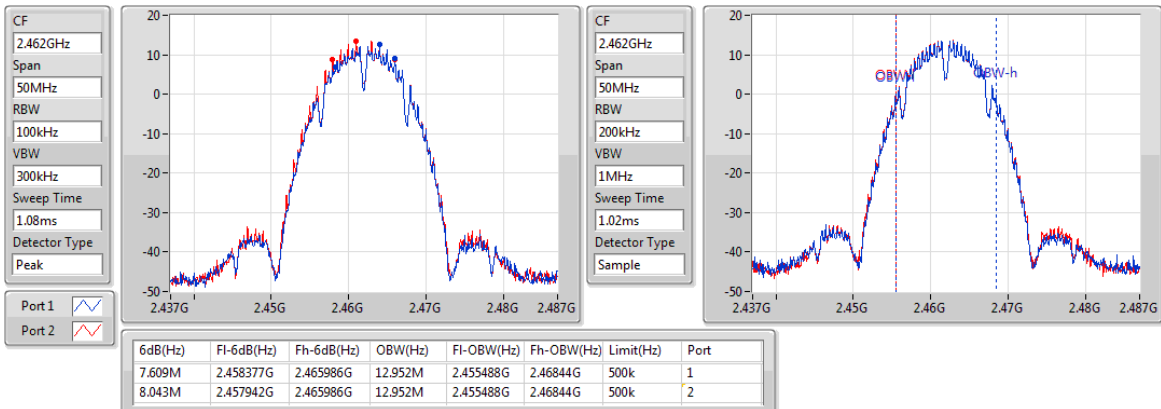

802.11g_Nss1,(6Mbps)_2TX

EBW

2412MHz

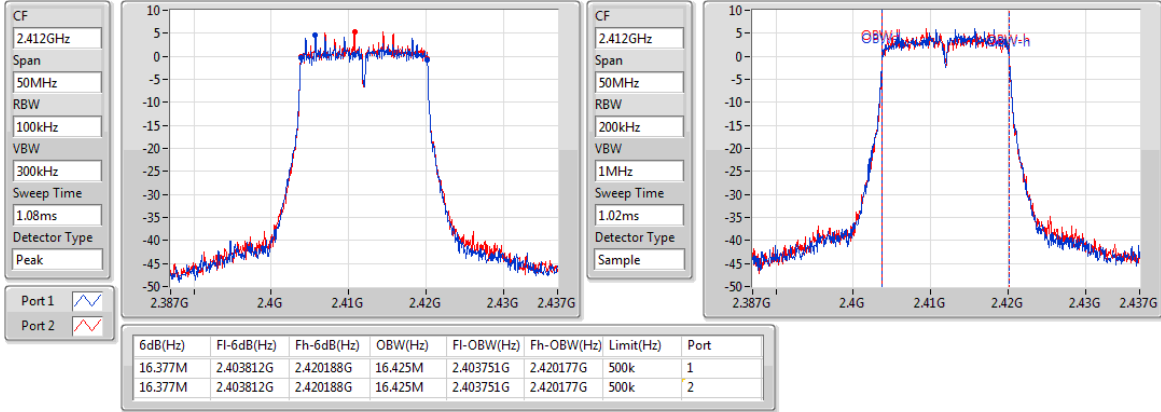

802.11g_Nss1,(6Mbps)_2TX

EBW

2437MHz

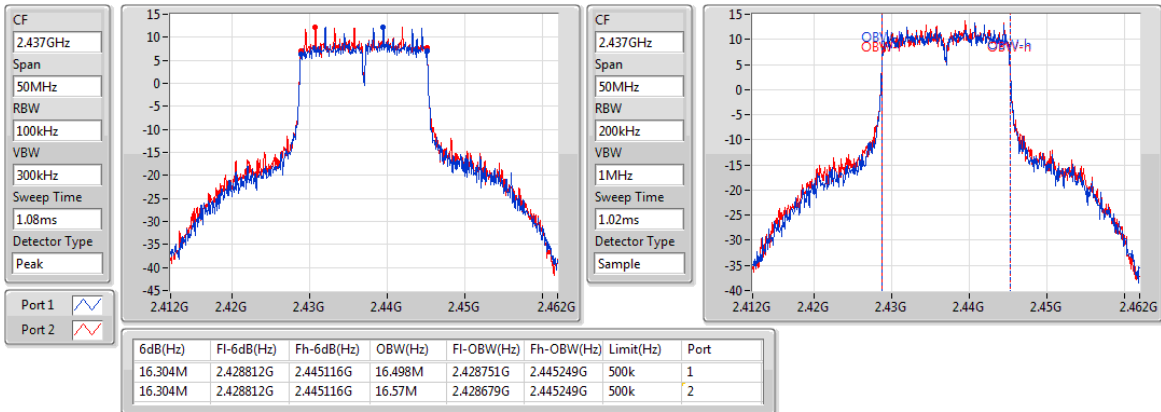

802.11g_Nss1,(6Mbps)_2TX

EBW

2462MHz

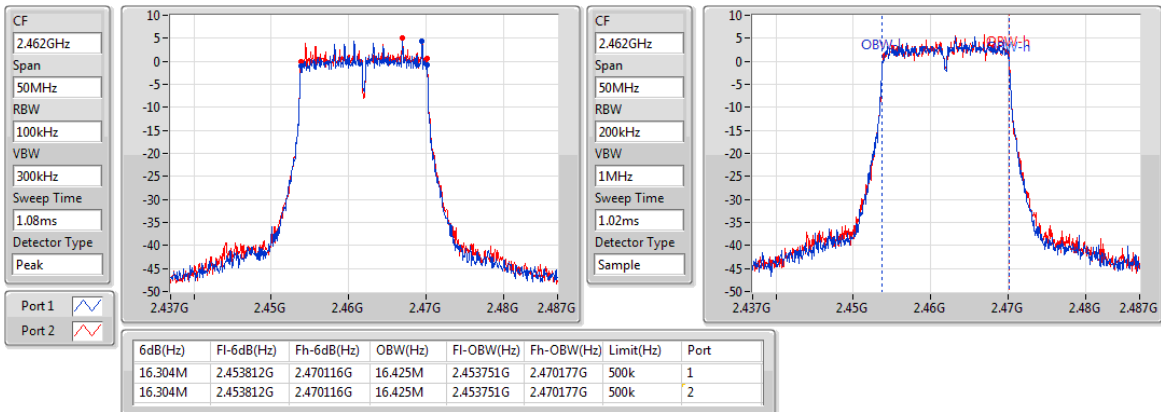

802.11n HT20_Nss1,(MCS0)_2TX

EBW

2412MHz

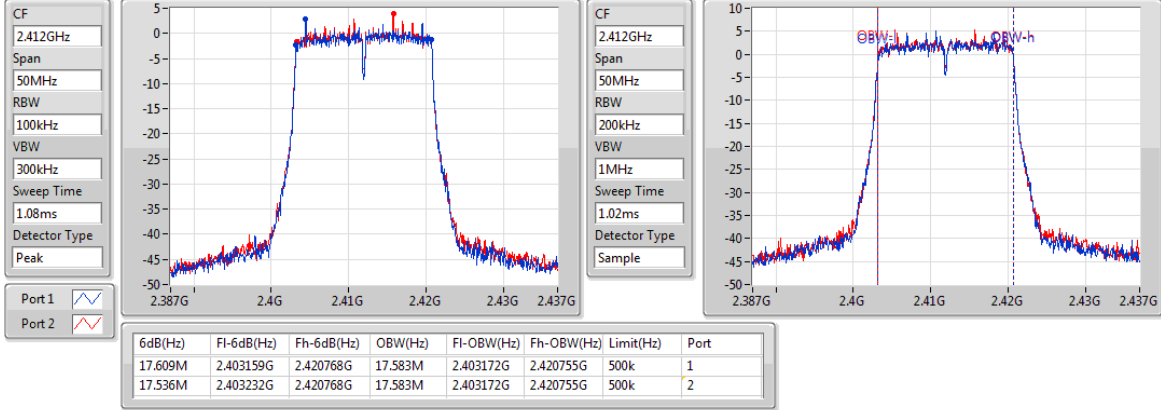

802.11n HT20_Nss1,(MCS0)_2TX

EBW

2437MHz

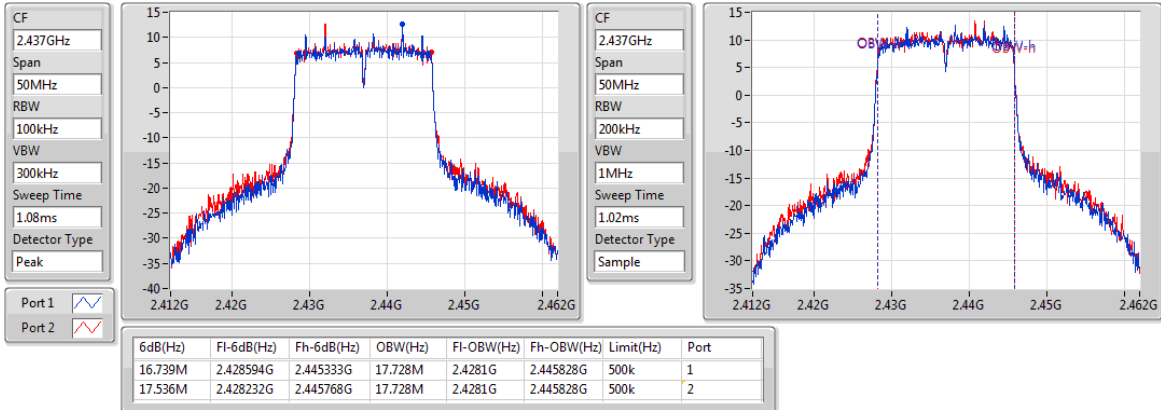

802.11n HT20_Nss1,(MCS0)_2TX

EBW

2462MHz

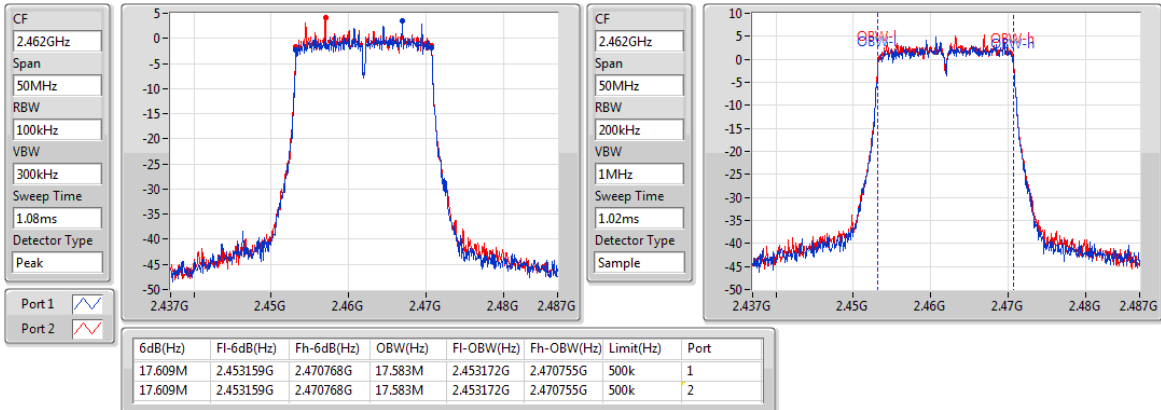

802.11n HT40_Nss1,(MCS0)_2TX

EBW

2422MHz

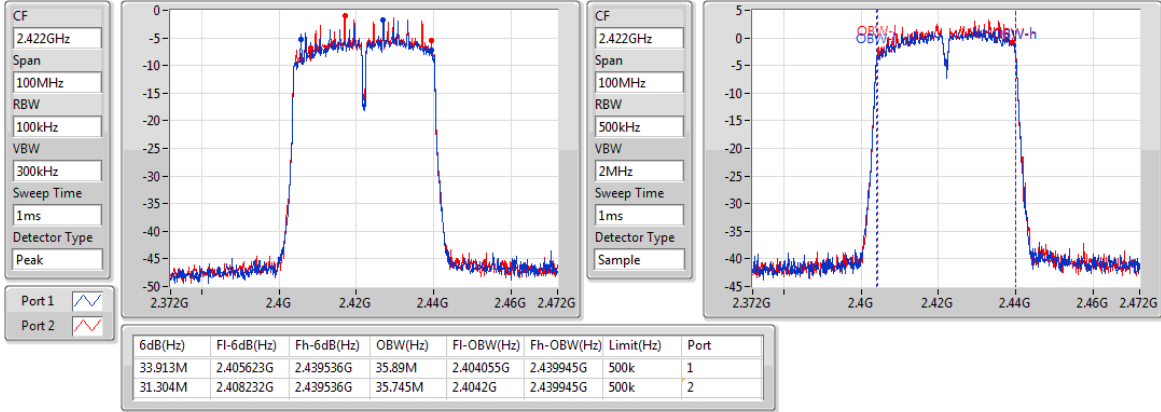

802.11n HT40_Nss1,(MCS0)_2TX

EBW

2437MHz

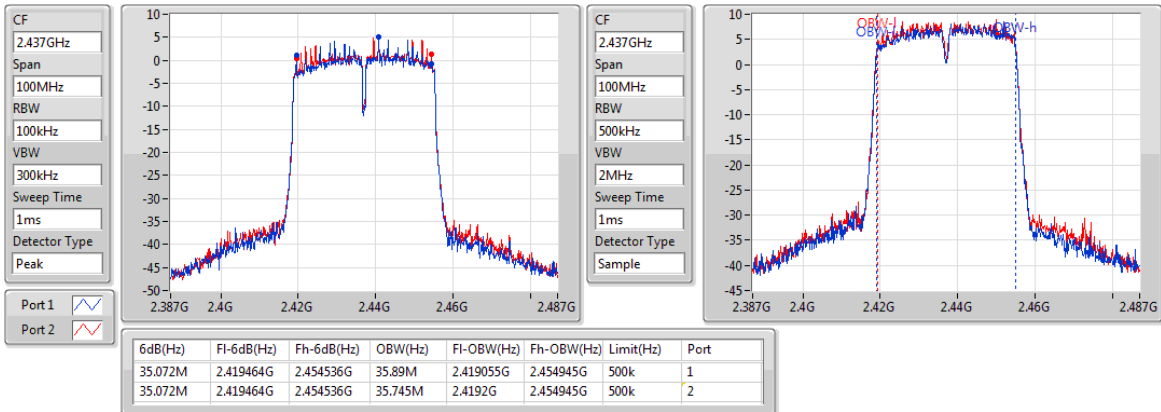

802.11n HT40_Nss1,(MCS0)_2TX

EBW

2452MHz

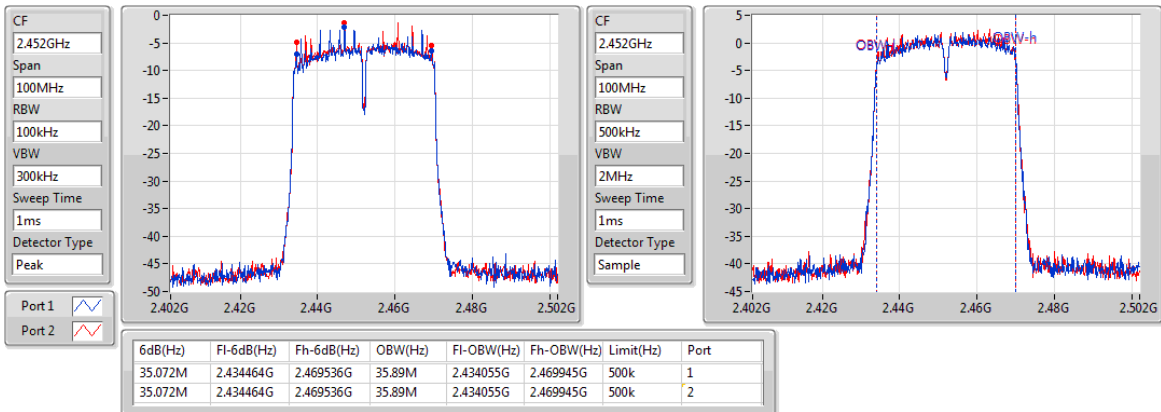

Beamforming mode

Summary

Mode	Max-N dB (Hz)	Max-OBW (Hz)	ITU-Code	Min-N dB (Hz)	Min-OBW (Hz)
2.4-2.4835GHz	-	-	-	-	-
802.11n HT20-BF_Nss1,(MCS0)_2T X	17.609M	17.583M	17M6D1D	14.058M	17.438M
802.11n HT40-BF_Nss1,(MCS0)_2T X	33.913M	36.035M	36M0D1D	30.145M	35.456M

Max-N dB = Maximum6dB downbandwidth;**Max-OBW** = Maximum99% occupied bandwidth;
Min-N dB = Minimum6dB downbandwidth;**Min-OBW** = Minimum99% occupied bandwidth;

Result

Mode	Result	Limit (Hz)	Port 1 -N dB (Hz)	Port 1 -OBW (Hz)	Port 2 -N dB (Hz)	Port 2 -OBW (Hz)
802.11n HT20-BF_Nss1,(MCS0)_2TX	-	-	-	-	-	-
2412MHz	Pass	500k	14.058M	17.583M	17.391M	17.583M
2437MHz	Pass	500k	16.304M	17.511M	15M	17.583M
2462MHz	Pass	500k	17.029M	17.438M	17.609M	17.583M
802.11n HT40-BF_Nss1,(MCS0)_2TX	-	-	-	-	-	-
2422MHz	Pass	500k	31.304M	35.745M	31.304M	35.745M
2437MHz	Pass	500k	33.913M	36.035M	30.145M	35.456M
2452MHz	Pass	500k	31.304M	35.745M	31.304M	35.601M

Port X-N dB = Port X6dB downbandwidth; **Port X-OBW** = Port X99% occupied bandwidth;

802.11n HT20-BF_Nss1,(MCS0)_2TX

EBW

2412MHz

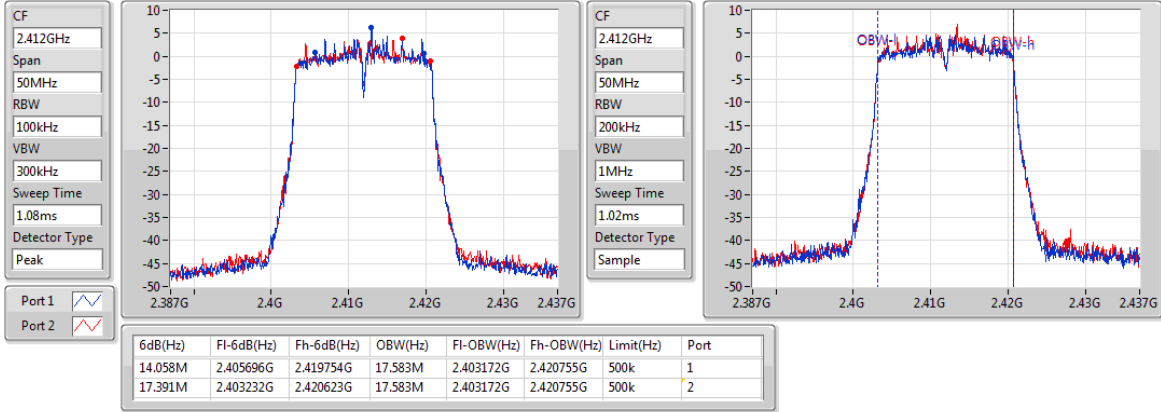

802.11n HT20-BF_Nss1,(MCS0)_2TX

EBW

2437MHz

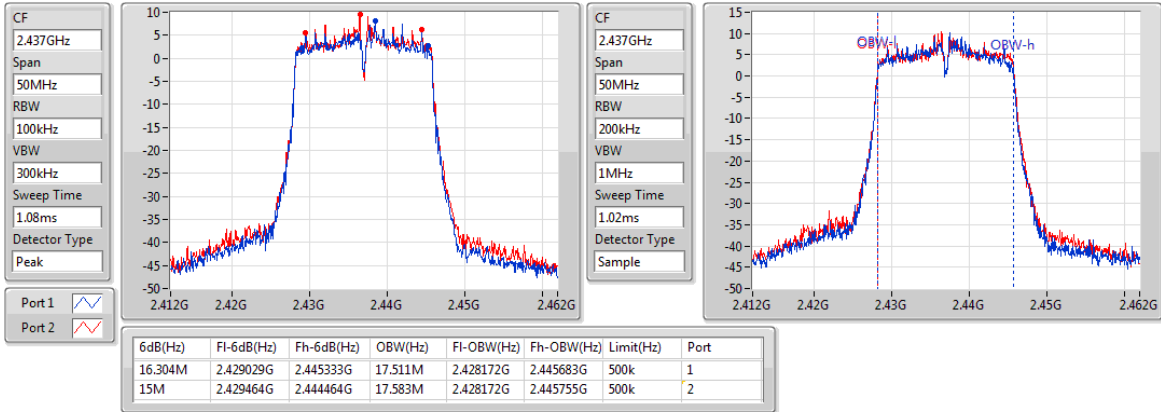

802.11n HT20-BF_Nss1,(MCS0)_2TX

EBW

2462MHz

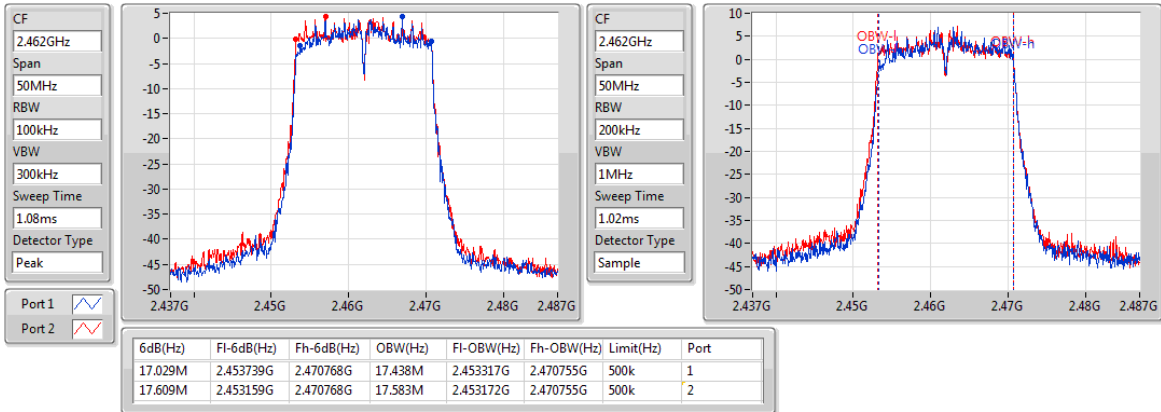

802.11n HT40-BF_Nss1,(MCS0)_2TX

EBW

2422MHz

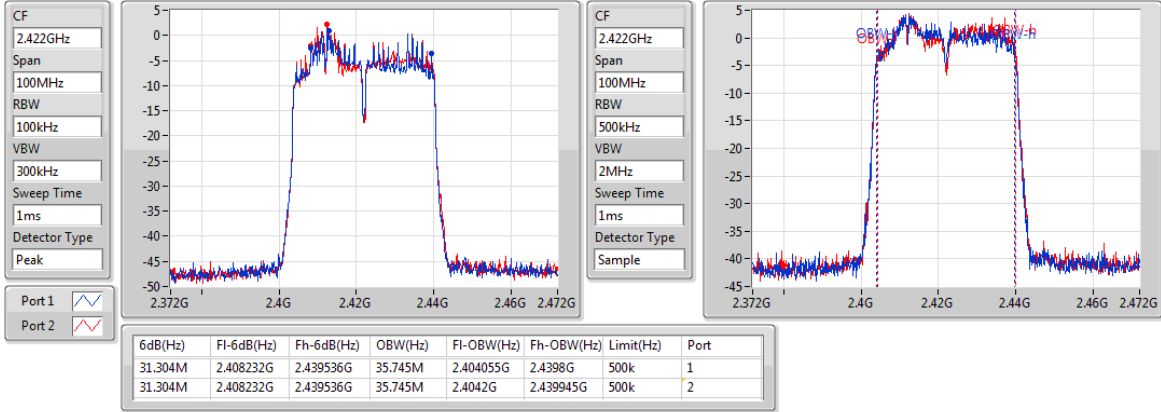

802.11n HT40-BF_Nss1,(MCS0)_2TX

EBW

2437MHz

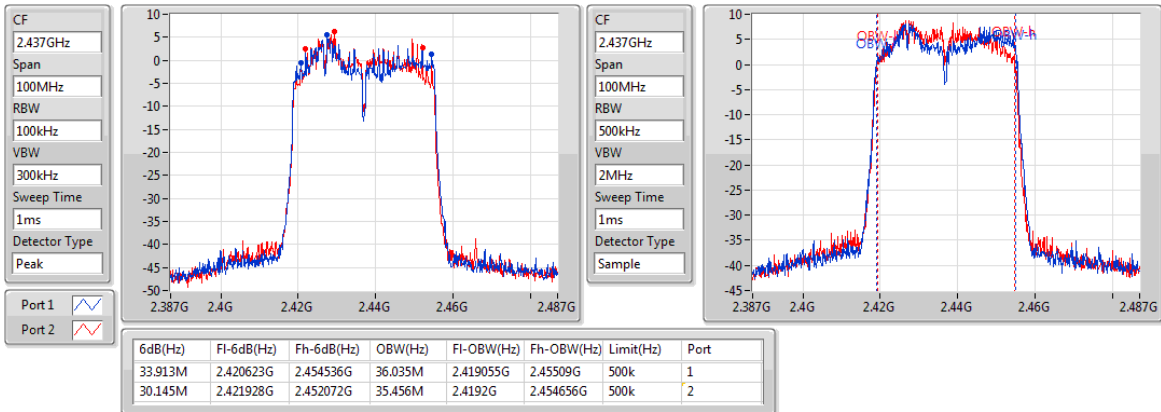

802.11n HT40-BF_Nss1,(MCS0)_2TX

EBW

2452MHz

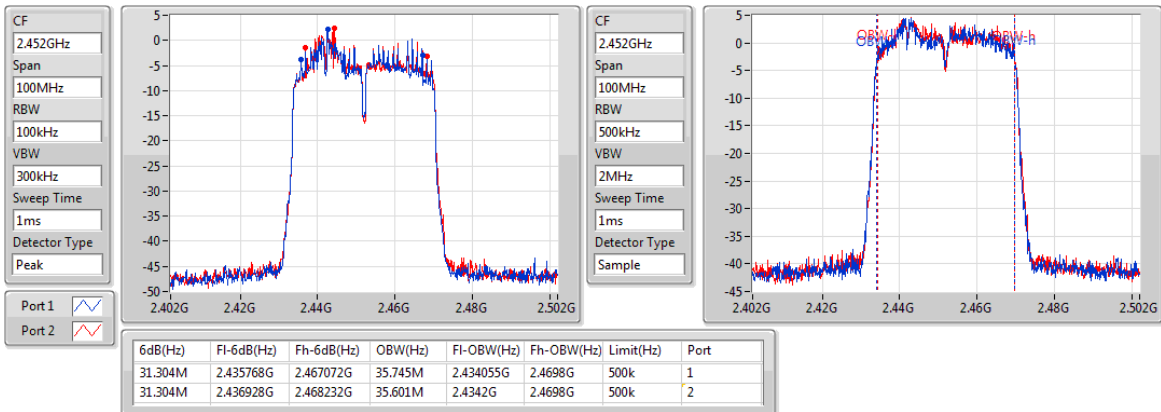

3.3 RF Output Power

3.3.1 Limit of RF Output Power

Conducted power shall not exceed 1Watt.

Antenna gain $\leq 6\text{dBi}$, no any corresponding reduction is in output power limit.

Antenna gain $> 6\text{dBi}$

Non Fixed, point to point operations.

The conducted output power from the intentional radiator shall be reduced by the amount in dB that the directional gain of the antenna exceeds 6 dB

Fixed, point to point operations

Systems operating in the 2400–2483.5 MHz band that are used exclusively for fixed, point-to-point Operations, maximum peak output power of the intentional radiator is reduced by 1 dB for every 3 dB that the directional gain of the antenna exceeds 6 dBi.

3.3.2 Test Procedures

A broadband RF power meter is used for output power measurement. The video bandwidth of power meter is greater than DTS bandwidth of EUT. If duty cycle of test signal is not 100 %, trigger and gating function of power meter will be enabled to capture transmission burst for measuring output power.

3.3.3 Test Setup



3.3.4 Test Result of Maximum Output Power

Non-beamforming mode

Summary of Average Conducted Output Power

Mode	Total Power (dBm)	Total Power (W)
2.4-2.4835GHz	-	-
802.11b_Nss1,(1Mbps)_2TX	28.22	0.66374
802.11g_Nss1,(6Mbps)_2TX	26.38	0.43451
802.11n HT20_Nss1,(MCS0)_2TX	26.33	0.42954
802.11n HT40_Nss1,(MCS0)_2TX	21.58	0.14388

Result

Mode	Result	DG (dBi)	Port 1 (dBm)	Port 2 (dBm)	Total Power (dBm)	Power Limit (dBm)	EIRP (dBm)	EIRP Limit (dBm)
802.11b_Nss1,(1Mbps)_2TX	-	-	-	-	-	-	-	-
2412MHz	Pass	3.40	22.17	22.61	25.41	30.00	28.81	36.00
2437MHz	Pass	3.40	24.95	25.45	28.22	30.00	31.62	36.00
2462MHz	Pass	3.40	21.58	21.89	24.75	30.00	28.15	36.00
802.11g_Nss1,(6Mbps)_2TX	-	-	-	-	-	-	-	-
2412MHz	Pass	3.40	16.39	16.73	19.57	30.00	22.97	36.00
2437MHz	Pass	3.40	23.15	23.58	26.38	30.00	29.78	36.00
2462MHz	Pass	3.40	15.61	16.15	18.90	30.00	22.30	36.00
802.11n HT20_Nss1,(MCS0)_2TX	-	-	-	-	-	-	-	-
2412MHz	Pass	3.40	14.95	15.34	18.16	30.00	21.56	36.00
2437MHz	Pass	3.40	23.13	23.51	26.33	30.00	29.73	36.00
2462MHz	Pass	3.40	15.15	15.67	18.43	30.00	21.83	36.00
802.11n HT40_Nss1,(MCS0)_2TX	-	-	-	-	-	-	-	-
2422MHz	Pass	3.40	12.22	12.63	15.44	30.00	18.84	36.00
2437MHz	Pass	3.40	18.34	18.79	21.58	30.00	24.98	36.00
2452MHz	Pass	3.40	11.96	12.34	15.16	30.00	18.56	36.00

DG = Directional Gain; **Port X** = Port X output power

Beamforming mode

Summary of Average Conducted Output Power

Mode	Total Power (dBm)	Total Power (W)
2.4-2.4835GHz	-	-
802.11n HT20-BF_Nss1,(MCS0)_2TX	21.29	0.13459
802.11n HT40-BF_Nss1,(MCS0)_2TX	19.17	0.08260

Result

Mode	Result	DG (dBi)	Port 1 (dBm)	Port 2 (dBm)	Total Power (dBm)	Power Limit (dBm)	EIRP (dBm)	EIRP Limit (dBm)
802.11n HT20-BF_Nss1,(MCS0)_2T X	-	-	-	-	-	-	-	-
2412MHz	Pass	6.41	15.11	15.06	18.10	29.59	24.51	36.00
2437MHz	Pass	6.41	18.20	18.35	21.29	29.59	27.70	36.00
2462MHz	Pass	6.41	15.35	15.26	18.32	29.59	24.73	36.00
802.11n HT40-BF_Nss1,(MCS0)_2T X	-	-	-	-	-	-	-	-
2422MHz	Pass	6.41	12.25	12.55	15.41	29.59	21.82	36.00
2437MHz	Pass	6.41	15.90	16.40	19.17	29.59	25.58	36.00
2452MHz	Pass	6.41	11.88	12.29	15.10	29.59	21.51	36.00

DG = Directional Gain; **Port X** = Port X output power

Note:

Directional gain = $3.4 \text{ dBi} + 10 \cdot \log(2/1) = 6.41 \text{ dBi} > 6 \text{ dBi}$

Limit shall be reduced to $30 \text{ dBm} - (6.41 \text{ dBi} - 6 \text{ dBi}) = 29.59 \text{ dBm}$

3.4 Power Spectral Density

3.4.1 Limit of Power Spectral Density

Power spectral density shall not be greater than 8 dBm in any 3 kHz band.

3.4.2 Test Procedures

Peak PSD

1. Set the RBW = 3 kHz, VBW = 10 kHz.
2. Detector = Peak, Sweep time = auto couple.
3. Trace mode = max hold, allow trace to fully stabilize.
4. Use the peak marker function to determine the maximum amplitude level.

Average PSD, duty cycle $\geq 98\%$

1. Set the RBW = 30 kHz, VBW = 100 kHz.
2. Detector = RMS, Sweep time = auto couple.
3. Sweep time = auto couple.
4. Employ trace averaging (RMS) mode over a minimum of 100 traces.
5. Use the peak marker function to determine the maximum amplitude level.

Average PSD, duty cycle $< 98\%$

1. Set the RBW = 30 kHz, VBW = 100 kHz. Detector = RMS.
2. Set the sweep time to: ≥ 10 (number of measurement points in sweep) x (total on/off period of the transmitted signal).
3. Perform the measurement over a single sweep.
4. Use the peak marker function to determine the maximum amplitude level.
5. Add $10 \log (1/x)$, where x is the duty cycle.

3.4.3 Test Setup

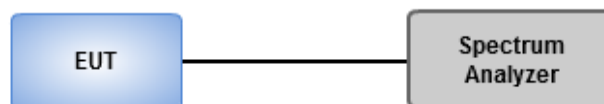

3.4.4 Test Result of Power Spectral Density

Non-beamforming mode

Summary

Mode	PD (dBm/RBW)
2.4-2.4835GHz	-
802.11b_Nss1,(1Mbps)_2TX	6.27
802.11g_Nss1,(6Mbps)_2TX	1.14
802.11n HT20_Nss1,(MCS0)_2TX	1.44
802.11n HT40_Nss1,(MCS0)_2TX	-6.72

RBW=3kHz.

Result

Mode	Result	DG (dBi)	Port 1 (dBm/RBW)	Port 2 (dBm/RBW)	PD (dBm/RBW)	PD Limit (dBm/RBW)
802.11b_Nss1,(1Mbps)_2TX	-	-	-	-	-	-
2412MHz	Pass	6.41	0.38	2.39	4.22	7.59
2437MHz	Pass	6.41	3.42	3.71	6.27	7.59
2462MHz	Pass	6.41	0.22	0.21	3.07	7.59
802.11g_Nss1,(6Mbps)_2TX	-	-	-	-	-	-
2412MHz	Pass	6.41	-8.90	-8.71	-5.90	7.59
2437MHz	Pass	6.41	-1.99	-1.46	1.14	7.59
2462MHz	Pass	6.41	-9.71	-9.15	-6.49	7.59
802.11n HT20_Nss1,(MCS0)_2TX	-	-	-	-	-	-
2412MHz	Pass	6.41	-9.38	-8.77	-6.19	7.59
2437MHz	Pass	6.41	-1.30	-1.05	1.44	7.59
2462MHz	Pass	6.41	-9.40	-9.02	-6.49	7.59
802.11n HT40_Nss1,(MCS0)_2TX	-	-	-	-	-	-
2422MHz	Pass	6.41	-16.04	-15.66	-12.84	7.59
2437MHz	Pass	6.41	-9.88	-9.47	-6.72	7.59
2452MHz	Pass	6.41	-16.33	-16.03	-13.22	7.59

DG = Directional Gain;

PD = trace bin-by-bin of each transmits port summing can be performed maximum power density; **Port X** = Port Xpower density;

Note:

Directional gain = $3.4 \text{ dBi} + 10 \cdot \log(2/1) = 6.41 \text{ dBi} > 6 \text{ dBi}$

Limit shall be reduced to $8 \text{ dBm} - (6.41 \text{ dBi} - 6 \text{ dBi}) = 7.59 \text{ dBm}$

802.11b_Nss1,(1Mbps)_2TX

PSD

2412MHz

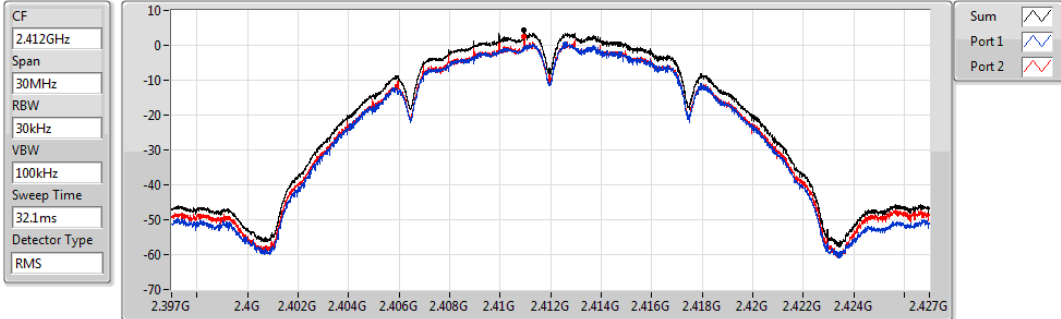

Sum	PD	Port 1	Port 2
(dBm/RBW)	(dBm/RBW)	(dBm/RBW)	(dBm/RBW)
4.22	4.22	0.38	2.39

802.11b_Nss1,(1Mbps)_2TX

PSD

2437MHz

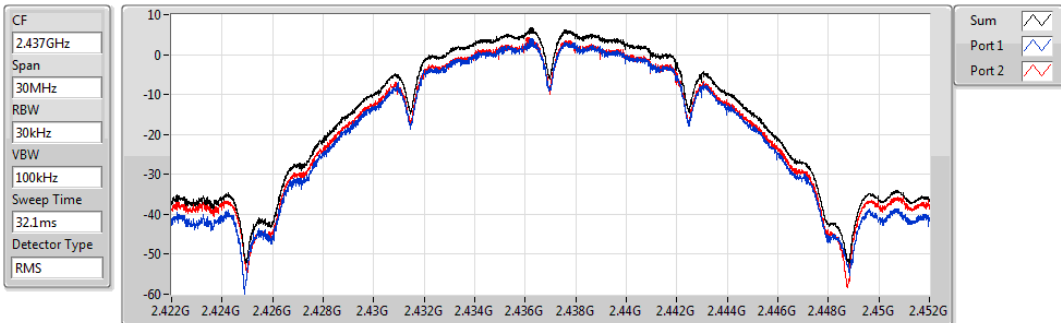

Sum	PD	Port 1	Port 2
(dBm/RBW)	(dBm/RBW)	(dBm/RBW)	(dBm/RBW)
6.27	6.27	3.42	3.71

802.11b_Nss1,(1Mbps)_2TX

PSD

2462MHz

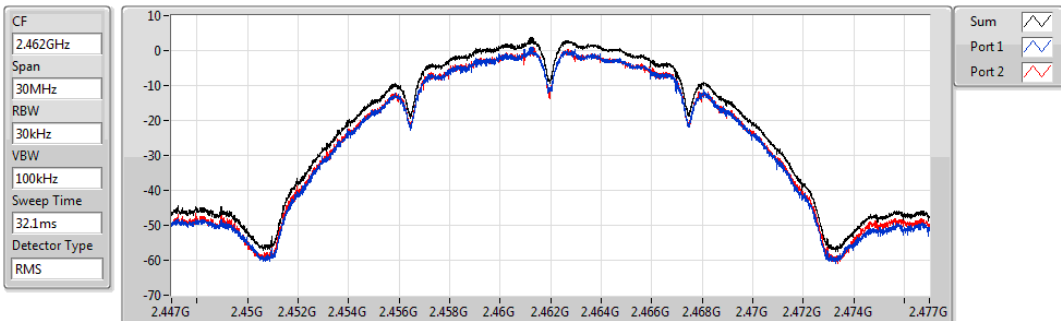

Sum	PD	Port 1	Port 2
(dBm/RBW)	(dBm/RBW)	(dBm/RBW)	(dBm/RBW)
3.07	3.07	0.22	0.21

802.11g_Nss1,(6Mbps)_2TX

PSD

2412MHz

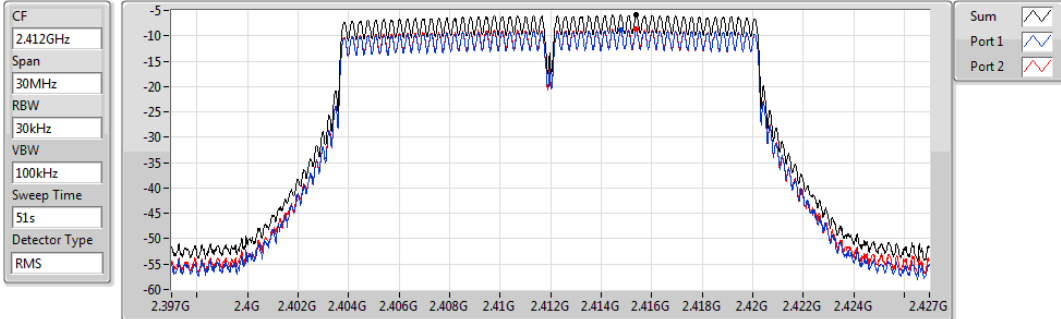

Sum	PD	Port 1	Port 2
(dBm/RBW)	(dBm/RBW)	(dBm/RBW)	(dBm/RBW)
-5.90	-5.90	-8.90	-8.71

802.11g_Nss1,(6Mbps)_2TX

PSD

2437MHz

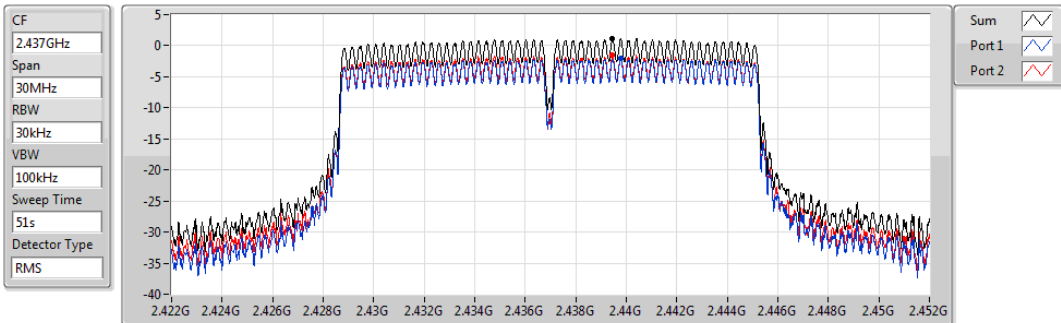

Sum	PD	Port 1	Port 2
(dBm/RBW)	(dBm/RBW)	(dBm/RBW)	(dBm/RBW)
1.14	1.14	-1.99	-1.46

802.11g_Nss1,(6Mbps)_2TX

PSD

2462MHz

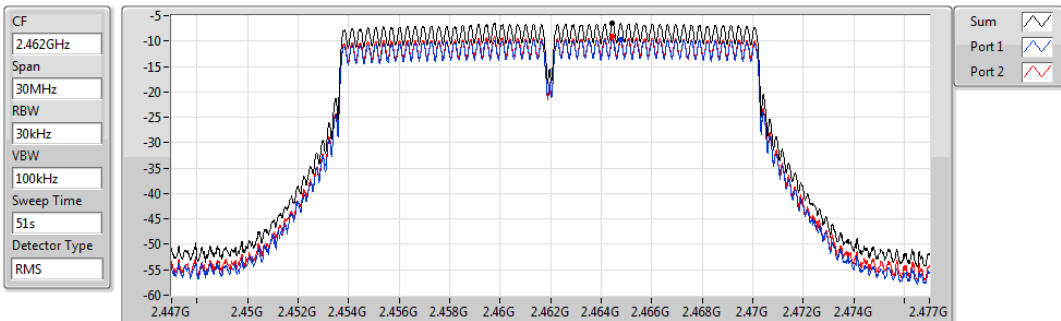

Sum	PD	Port 1	Port 2
(dBm/RBW)	(dBm/RBW)	(dBm/RBW)	(dBm/RBW)
-6.49	-6.49	-9.71	-9.15

802.11n HT20_Nss1,(MCS0)_2TX

PSD

2412MHz

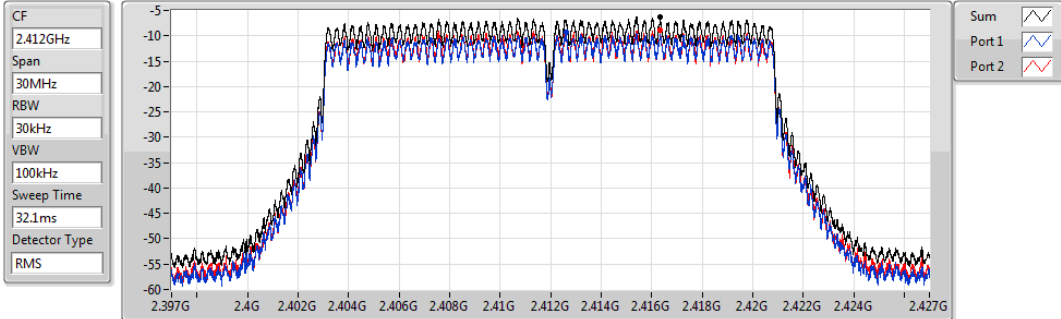

Sum	PD	Port 1	Port 2
(dBm/100kHz)	(dBm/100kHz)	(dBm/100kHz)	(dBm/100kHz)
-6.19	-6.19	-9.38	-8.77

802.11n HT20_Nss1,(MCS0)_2TX

PSD

2437MHz

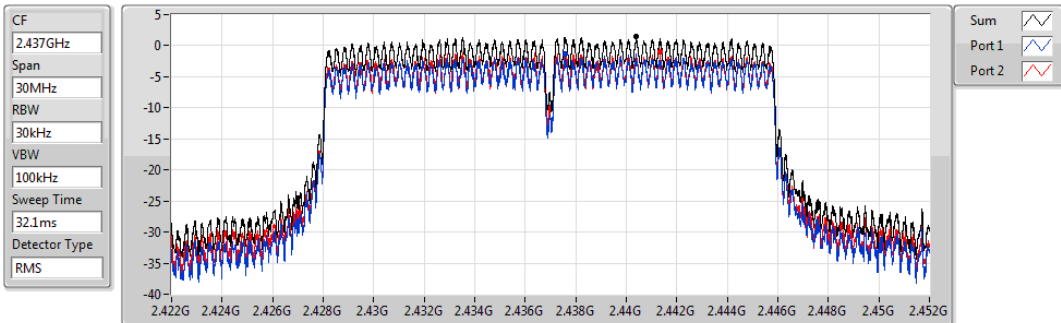

Sum	PD	Port 1	Port 2
(dBm/100kHz)	(dBm/100kHz)	(dBm/100kHz)	(dBm/100kHz)
1.44	1.44	-1.30	-1.05

802.11n HT20_Nss1,(MCS0)_2TX

PSD

2462MHz

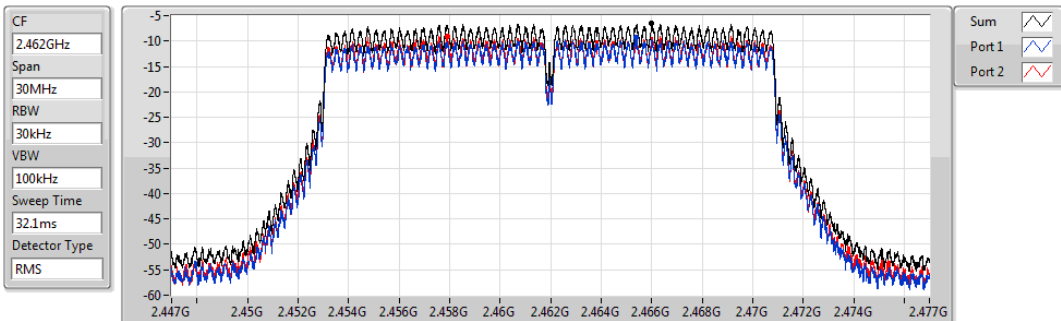

Sum	PD	Port 1	Port 2
(dBm/100kHz)	(dBm/100kHz)	(dBm/100kHz)	(dBm/100kHz)
-6.49	-6.49	-9.40	-9.02

802.11n HT40_Nss1,(MCS0)_2TX

PSD

2422MHz

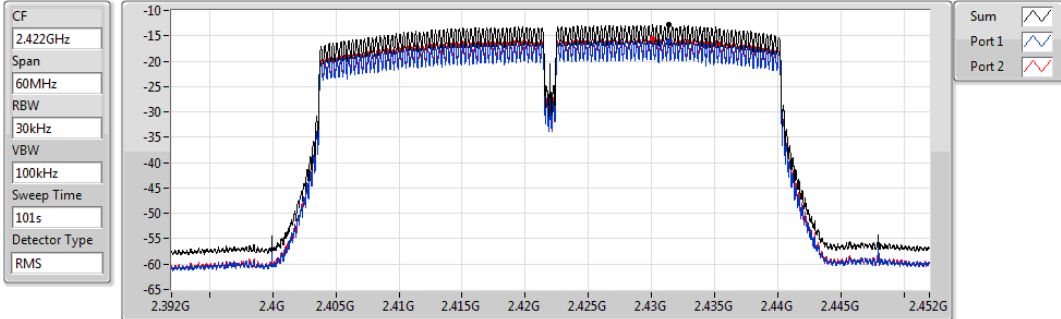

Sum	PD	Port 1	Port 2
(dBm/100kHz)	(dBm/100kHz)	(dBm/100kHz)	(dBm/100kHz)
-12.84	-12.84	-16.04	-15.66

802.11n HT40_Nss1,(MCS0)_2TX

PSD

2437MHz

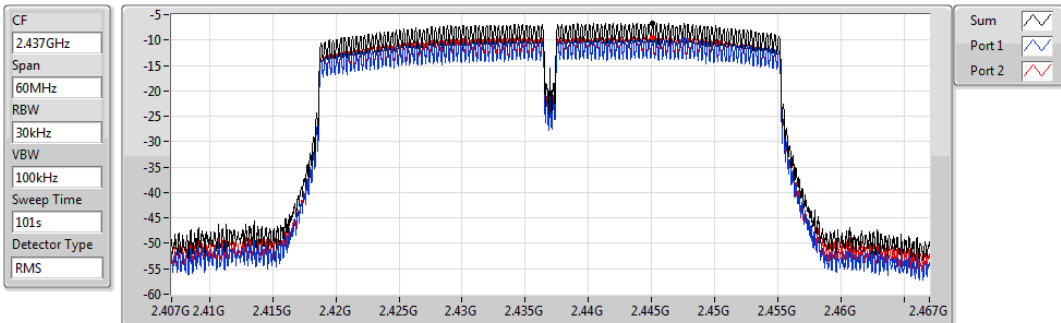

Sum	PD	Port 1	Port 2
(dBm/100kHz)	(dBm/100kHz)	(dBm/100kHz)	(dBm/100kHz)
-6.72	-6.72	-9.88	-9.47

802.11n HT40_Nss1,(MCS0)_2TX

PSD

2452MHz

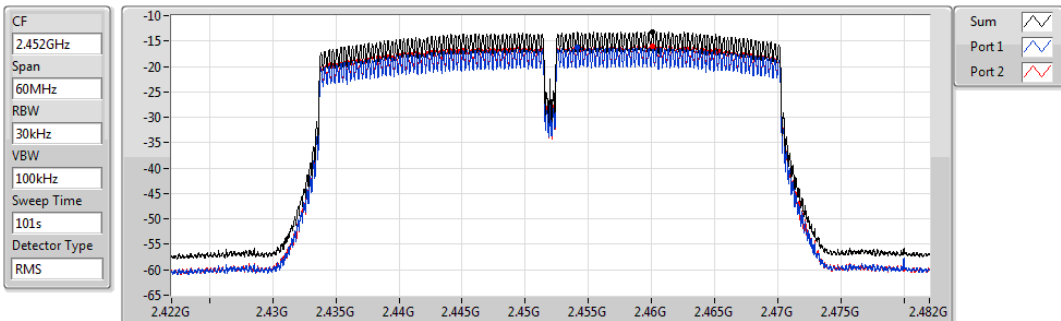

Sum	PD	Port 1	Port 2
(dBm/100kHz)	(dBm/100kHz)	(dBm/100kHz)	(dBm/100kHz)
-13.22	-13.22	-16.33	-16.03

Beamforming mode

Summary

Mode	PD (dBm/RBW)
2.4-2.4835GHz	-
802.11n HT20-BF_Nss1,(MCS0)_2TX	-4.39
802.11n HT40-BF_Nss1,(MCS0)_2TX	-8.69

RBW=3kHz.

Result

Mode	Result	DG (dBi)	Port 1 (dBm/RBW)	Port 2 (dBm/RBW)	PD (dBm/RBW)	PD Limit (dBm/RBW)
802.11n HT20-BF_Nss1,(MCS0)_2TX	-	-	-	-	-	-
2412MHz	Pass	6.41	-10.43	-10.18	-7.42	7.59
2437MHz	Pass	6.41	-7.09	-7.30	-4.39	7.59
2462MHz	Pass	6.41	-9.59	-9.86	-6.80	7.59
802.11n HT40-BF_Nss1,(MCS0)_2TX	-	-	-	-	-	-
2422MHz	Pass	6.41	-15.54	-15.59	-12.88	7.59
2437MHz	Pass	6.41	-11.52	-10.51	-8.69	7.59
2452MHz	Pass	6.41	-14.02	-14.00	-12.03	7.59

DG = Directional Gain;

PD = trace bin-by-bin of each transmits port summing can be performed maximum power density; **Port X** = Port X power density;

Note:

Directional gain = $3.4 \text{ dBi} + 10 \cdot \log(2/1) = 6.41 \text{ dBi} > 6 \text{ dBi}$

Limit shall be reduced to $8 \text{ dBm} - (6.41 \text{ dBi} - 6 \text{ dBi}) = 7.59 \text{ dBm}$

802.11n HT20-BF_Nss1,(MCS0)_2TX

PSD

2412MHz

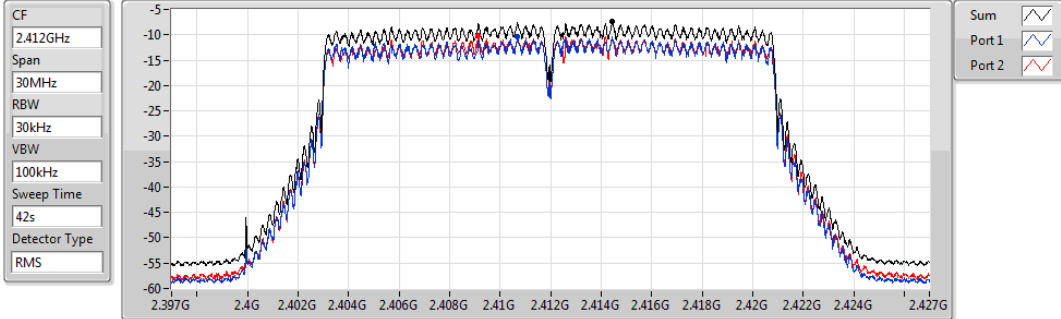

Sum	PD	Port 1	Port 2
(dBm/RBW)	(dBm/RBW)	(dBm/RBW)	(dBm/RBW)
-7.42	-7.42	-10.43	-10.18

802.11n HT20-BF_Nss1,(MCS0)_2TX

PSD

2437MHz

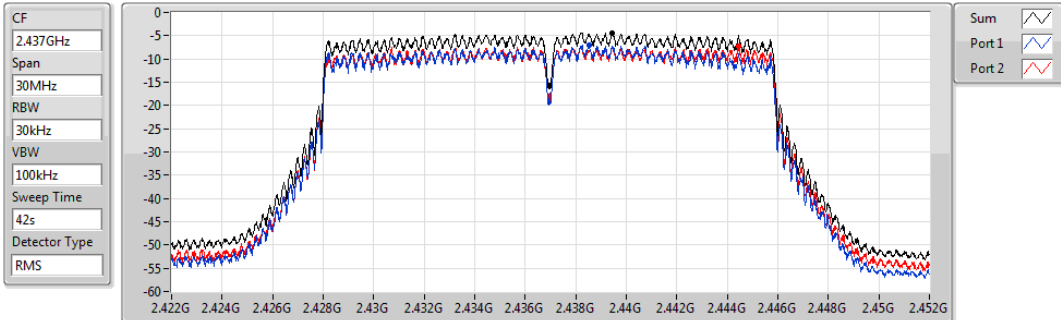

Sum	PD	Port 1	Port 2
(dBm/RBW)	(dBm/RBW)	(dBm/RBW)	(dBm/RBW)
-4.39	-4.39	-7.09	-7.30

802.11n HT20-BF_Nss1,(MCS0)_2TX

PSD

2462MHz

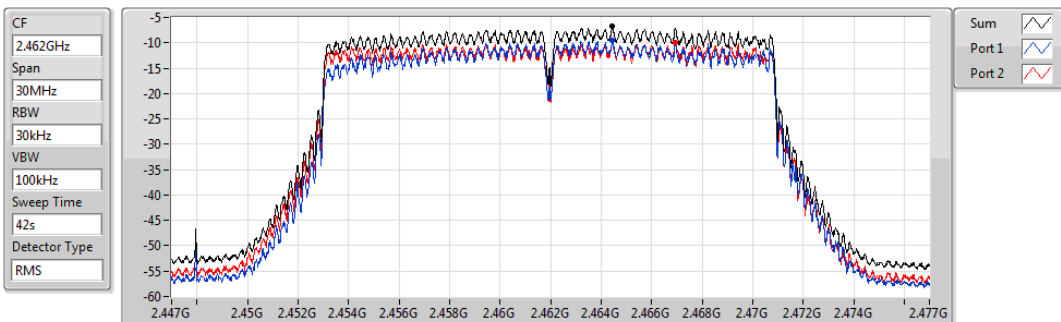

Sum	PD	Port 1	Port 2
(dBm/RBW)	(dBm/RBW)	(dBm/RBW)	(dBm/RBW)
-6.80	-6.80	-9.59	-9.86

802.11n HT40-BF_Nss1,(MCS0)_2TX

PSD

2422MHz

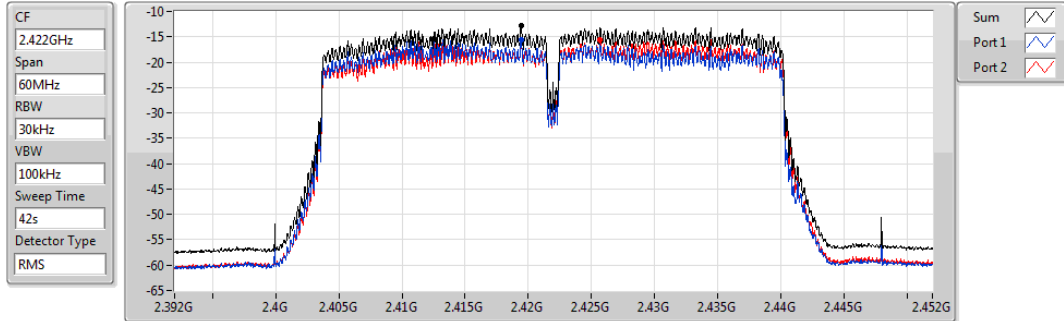

Sum	PD	Port 1	Port 2
(dBm/100kHz)	(dBm/100kHz)	(dBm/100kHz)	(dBm/100kHz)
-12.88	-12.88	-15.54	-15.59

802.11n HT40-BF_Nss1,(MCS0)_2TX

PSD

2437MHz

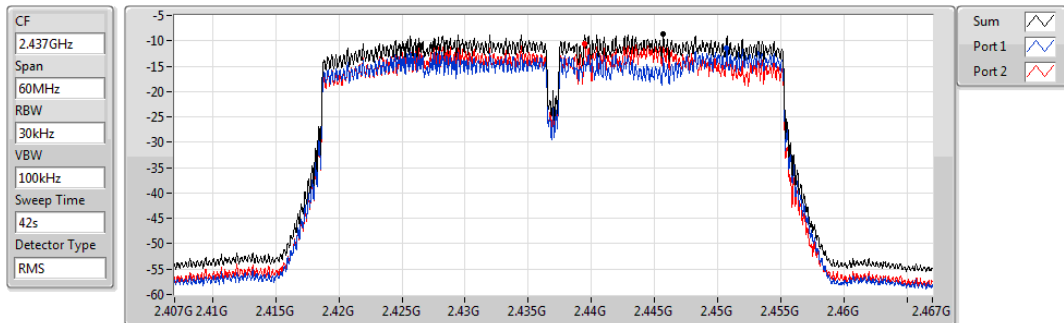

Sum	PD	Port 1	Port 2
(dBm/100kHz)	(dBm/100kHz)	(dBm/100kHz)	(dBm/100kHz)
-8.69	-8.69	-11.52	-10.51

802.11n HT40-BF_Nss1,(MCS0)_2TX

PSD

2452MHz

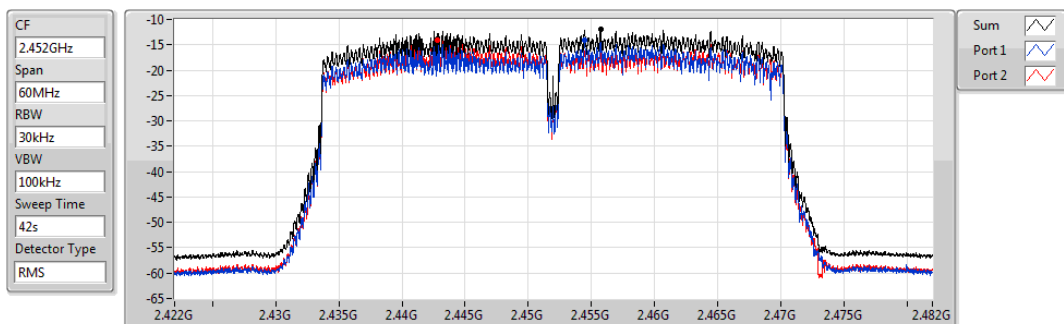

Sum	PD	Port 1	Port 2
(dBm/100kHz)	(dBm/100kHz)	(dBm/100kHz)	(dBm/100kHz)
-12.03	-12.03	-14.02	-14.00

3.5 Unwanted Emissions into Restricted Frequency Bands

3.5.1 Limit of Unwanted Emissions into Restricted Frequency Bands

Restricted Band Emissions Limit			
Frequency Range (MHz)	Field Strength (uV/m)	Field Strength (dBuV/m)	Measure Distance (m)
0.009~0.490	2400/F(kHz)	48.5 - 13.8	300
0.490~1.705	24000/F(kHz)	33.8 - 23	30
1.705~30.0	30	29	30
30~88	100	40	3
88~216	150	43.5	3
216~960	200	46	3
Above 960	500	54	3

Note 1:
 Qusai-Peak value is measured for frequency below 1GHz except for 9–90 kHz, 110–490 kHz frequency band. Peak and average value are measured for frequency above 1GHz. The limit on average radio frequency emission is as above table. The limit on peak radio frequency emissions is 20 dB above the maximum permitted average emission limit

Note 2:
 Measurements may be performed at a distance other than what is specified provided. When performing measurements at a distance other than that specified, the results shall be extrapolated to the specified distance using an extrapolation factor as below, Frequency at or above 30 MHz: 20 dB/decade Frequency below 30 MHz: 40 dB/decade.

3.5.2 Test Procedures

1. Measurement is made at a semi-anechoic chamber that incorporates a turntable allowing a EUT rotation of 360°. A continuously-rotating, remotely-controlled turntable is installed at the test site to support the EUT and facilitate determination of the direction of maximum radiation for each EUT emission frequency. The EUT is placed at test table. For emissions testing at or below 1 GHz, the table height is 80 cm above the reference ground plane. For emission measurements above 1 GHz, the table height is 1.5 m
2. Measurement is made with the antenna positioned in both the horizontal and vertical planes of polarization. The measurement antenna is varied in height (1m ~ 4m) above the reference ground plane to obtain the maximum signal strength. Distance between EUT and antenna is 3 m.
3. This investigation is performed with the EUT rotated 360°, the antenna height scanned between 1 m and 4 m, and the antenna rotated to repeat the measurements for both the horizontal and vertical antenna polarizations.

Note:

1. 120kHz measurement bandwidth of test receiver and Quasi-peak detector is for radiated emission below 1GHz.
2. RBW=1MHz, VBW=3MHz and Peak detector is for peak measured value of radiated emission above 1GHz.
3. RBW=1MHz, VBW=1/T and Peak detector is for average measured value of radiated emission above 1GHz.

3.5.3 Test Setup

Radiated Emissions below 1 GHz

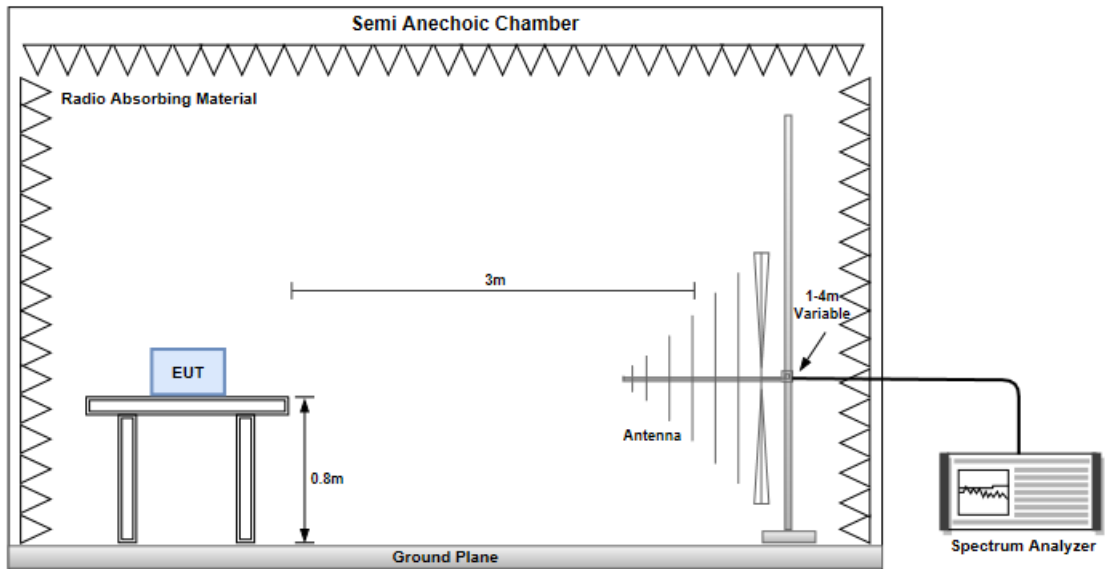

Radiated Emissions above 1 GHz

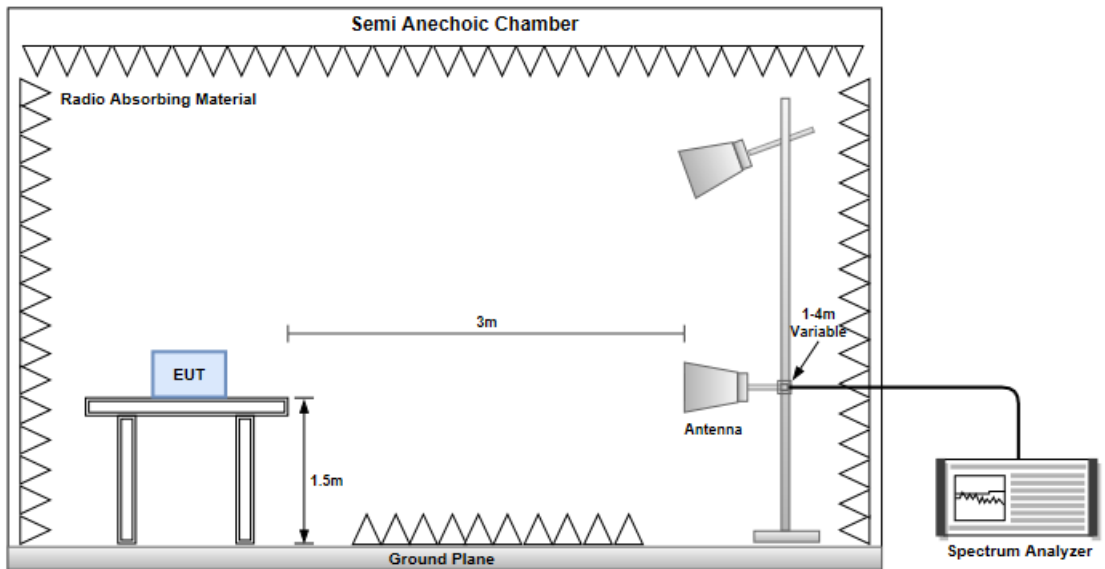

Non-beamforming mode

3.5.4 Transmitter Radiated Unwanted Emissions (Below 1GHz)

Modulation	11b	Test Freq. (MHz)	2437
Polarization	Horizontal	Test Configuration	1

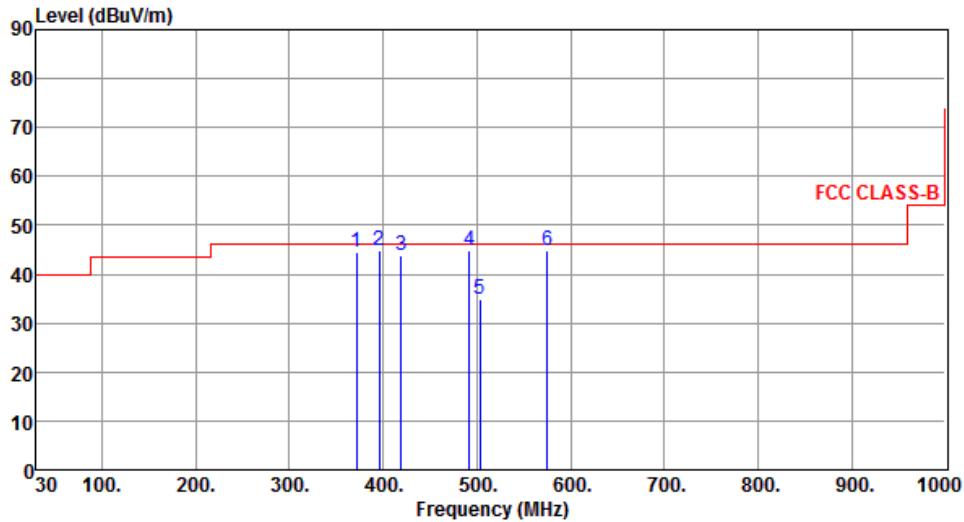

	Freq. MHz	Emission level dBuV/m	Limit dBuV/m	Margin dB	SA reading dBuV	Factor dB	Remark	ANT High cm	Turn Table deg
1	371.88	44.42	46.00	-1.58	50.13	-5.71	QP	100	120
2	395.88	44.84	46.00	-1.16	49.88	-5.04	QP	100	123
3	418.85	43.84	46.00	-2.16	48.28	-4.44	QP	100	121
4	491.88	44.71	46.00	-1.29	47.65	-2.94	QP	169	131
5	502.89	34.89	46.00	-11.11	37.64	-2.75	QP	187	56
6	575.21	44.71	46.00	-1.29	45.75	-1.04	QP	152	135

Note 1: Emission Level (dBuV/m) = SA Reading (dBuV/m) + Factor* (dB)

*Factor includes antenna factor , cable loss and amplifier gain

Note 2: Margin (dB) = Emission level (dBuV/m) – Limit (dBuV/m).

Note 3: All spurious emissions below 30MHz are more than 20 dB below the limit.

Modulation	11b	Test Freq. (MHz)	2437
Polarization	Vertical	Test Configuration	1

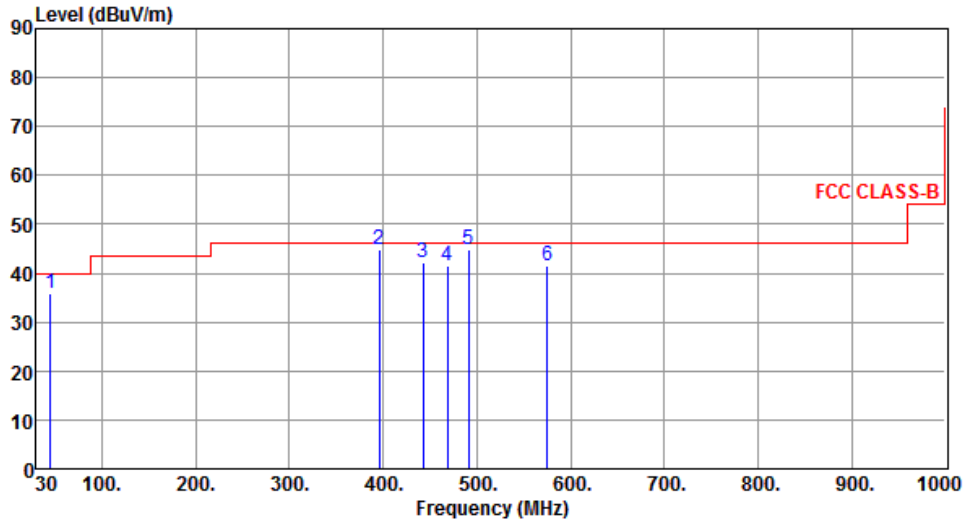

	Freq. MHz	Emission level dBuV/m	Limit dBuV/m	Margin dB	SA reading dBuV	Factor dB	Remark	ANT High cm	Turn Table deg
1	45.27	35.87	40.00	-4.13	43.97	-8.10	QP	100	119
2	396.02	44.83	46.00	-1.17	49.87	-5.04	QP	105	179
3	442.89	42.12	46.00	-3.88	45.94	-3.82	Peak	---	---
4	468.24	41.57	46.00	-4.43	44.89	-3.32	QP	100	122
5	491.58	44.78	46.00	-1.22	47.72	-2.94	QP	100	119
6	574.95	41.48	46.00	-4.52	42.53	-1.05	Peak	---	---

Note 1: Emission Level (dBuV/m) = SA Reading (dBuV/m) + Factor* (dB)

*Factor includes antenna factor , cable loss and amplifier gain

Note 2: Margin (dB) = Emission level (dBuV/m) – Limit (dBuV/m).

Note 3: All spurious emissions below 30MHz are more than 20 dB below the limit.

Modulation	11b	Test Freq. (MHz)	2437
Polarization	Horizontal	Test Configuration	2

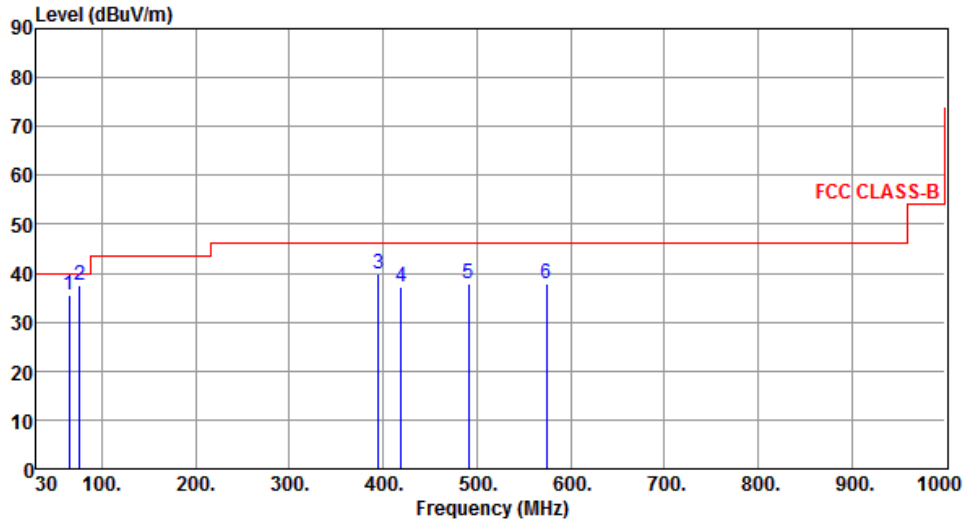

	Freq. MHz	Emission level dBuV/m	Limit dBuV/m	Margin dB	SA reading dBuV	Factor dB	Remark	ANT High cm	Turn Table deg
1	64.91	35.65	40.00	-4.35	45.22	-9.57	QP	100	59
2	76.41	37.62	40.00	-2.38	49.65	-12.03	QP	135	162
3	394.84	39.85	46.00	-6.15	44.91	-5.06	Peak	---	---
4	419.62	37.23	46.00	-8.77	41.65	-4.42	Peak	---	---
5	491.36	37.85	46.00	-8.15	40.79	-2.94	Peak	---	---
6	574.69	37.79	46.00	-8.21	38.85	-1.06	Peak	---	---

Note 1: Emission Level (dBuV/m) = SA Reading (dBuV/m) + Factor* (dB)

*Factor includes antenna factor , cable loss and amplifier gain

Note 2: Margin (dB) = Emission level (dBuV/m) – Limit (dBuV/m).

Note 3: All spurious emissions below 30MHz are more than 20 dB below the limit.

Modulation	11b	Test Freq. (MHz)	2437
Polarization	Vertical	Test Configuration	2

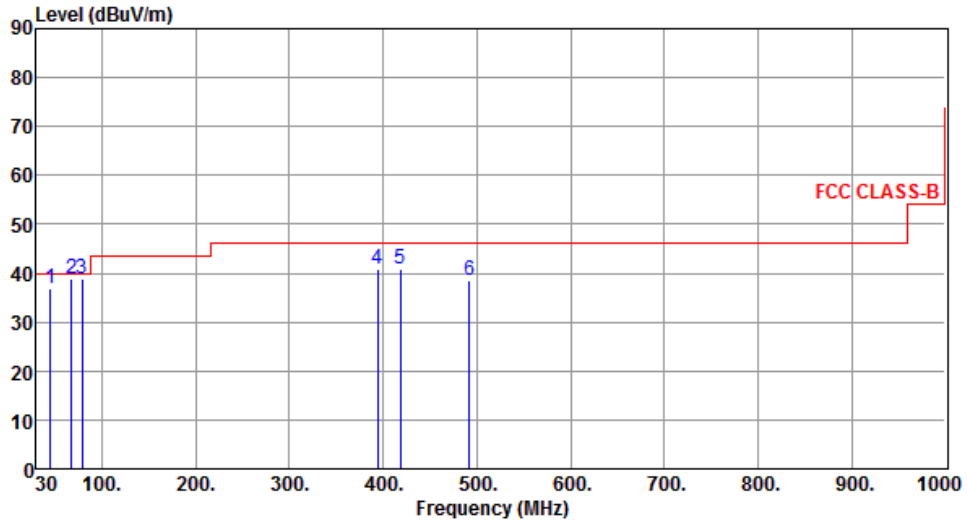

	Freq. MHz	Emission level dBuV/m	Limit dBuV/m	Margin dB	SA reading dBuV	Factor dB	Remark	ANT High cm	Turn Table deg
1	45.23	36.95	40.00	-3.05	45.05	-8.10	QP	100	99
2	67.48	38.96	40.00	-1.04	49.00	-10.04	QP	100	2
3	78.63	38.85	40.00	-1.15	51.38	-12.53	QP	162	182
4	394.58	40.74	46.00	-5.26	45.82	-5.08	Peak	---	---
5	418.58	40.69	46.00	-5.31	45.13	-4.44	Peak	---	---
6	492.23	38.47	46.00	-7.53	41.40	-2.93	Peak	---	---

Note 1: Emission Level (dBuV/m) = SA Reading (dBuV/m) + Factor* (dB)

*Factor includes antenna factor , cable loss and amplifier gain

Note 2: Margin (dB) = Emission level (dBuV/m) – Limit (dBuV/m).

Note 3: All spurious emissions below 30MHz are more than 20 dB below the limit.

3.5.5 Transmitter Radiated Unwanted Emissions (Above 1GHz) for 11b

Modulation	11b	Test Freq. (MHz)	2412
Polarization	Horizontal	Test Configuration	2

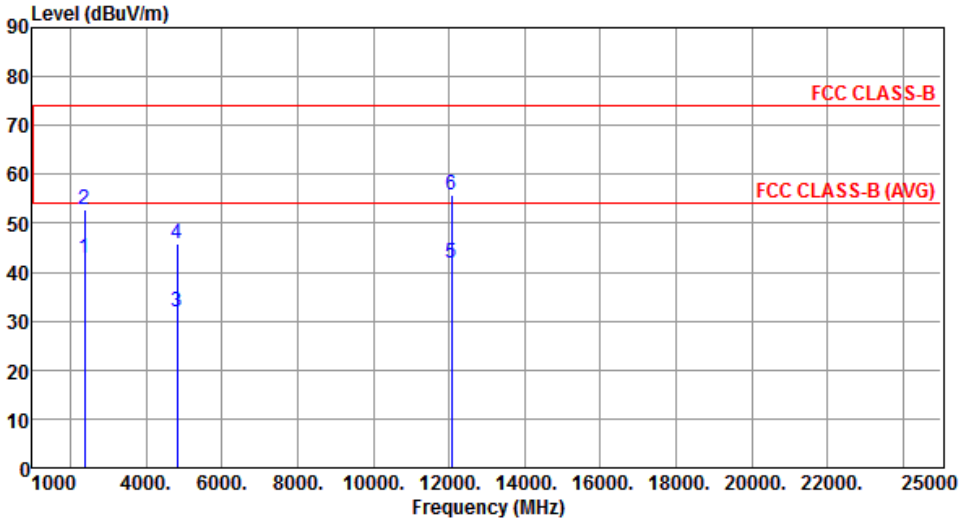

The graph plots Level (dBuV/m) on the y-axis (0 to 90) against Frequency (MHz) on the x-axis (1000 to 25000). Two horizontal red lines represent the FCC CLASS-B limit at approximately 74 dBuV/m and the FCC CLASS-B (AVG) limit at approximately 54 dBuV/m. Six vertical blue lines represent measured peaks, labeled 1 through 6, with their corresponding data listed in the table below.

	Freq. MHz	Emission level dBuV/m	Limit dBuV/m	Margin dB	SA reading dBuV	Factor dB	Remark	ANT High cm	Turn Table deg
1	2390.00	42.76	54.00	-11.24	43.72	-0.96	Average	135	225
2	2390.00	52.87	74.00	-21.13	53.83	-0.96	Peak	135	225
3	4824.00	32.00	54.00	-22.00	27.13	4.87	Average	100	33
4	4824.00	45.92	74.00	-28.08	41.05	4.87	Peak	100	33
5	12060.00	41.72	54.00	-12.28	26.80	14.92	Average	100	56
6	12060.00	55.85	74.00	-18.15	40.93	14.92	Peak	100	56

Note 1: Emission Level (dBuV/m) = SA Reading (dBuV/m) + Factor* (dB)
*Factor includes antenna factor , cable loss and amplifier gain
Note 2: Margin (dB) = Emission level (dBuV/m) – Limit (dBuV/m).

Modulation	11b	Test Freq. (MHz)	2412
Polarization	Vertical	Test Configuration	2

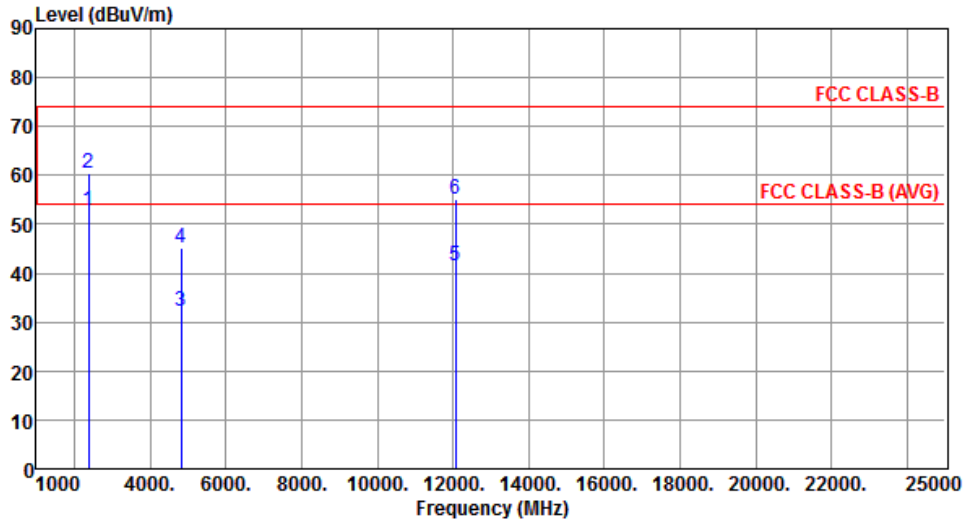

	Freq. MHz	Emission level dBuV/m	Limit dBuV/m	Margin dB	SA reading dBuV	Factor dB	Remark	ANT High cm	Turn Table deg
1	2390.00	52.91	54.00	-1.09	53.87	-0.96	Average	159	284
2	2390.00	60.44	74.00	-13.56	61.40	-0.96	Peak	159	284
3	4824.00	32.10	54.00	-21.90	27.23	4.87	Average	100	35
4	4824.00	45.12	74.00	-28.88	40.25	4.87	Peak	100	35
5	12060.00	41.62	54.00	-12.38	26.70	14.92	Average	100	49
6	12060.00	54.96	74.00	-19.04	40.04	14.92	Peak	100	49

Note 1: Emission Level (dBuV/m) = SA Reading (dBuV/m) + Factor* (dB)

*Factor includes antenna factor , cable loss and amplifier gain

Note 2: Margin (dB) = Emission level (dBuV/m) – Limit (dBuV/m).

Modulation	11b	Test Freq. (MHz)	2437
Polarization	Horizontal	Test Configuration	2

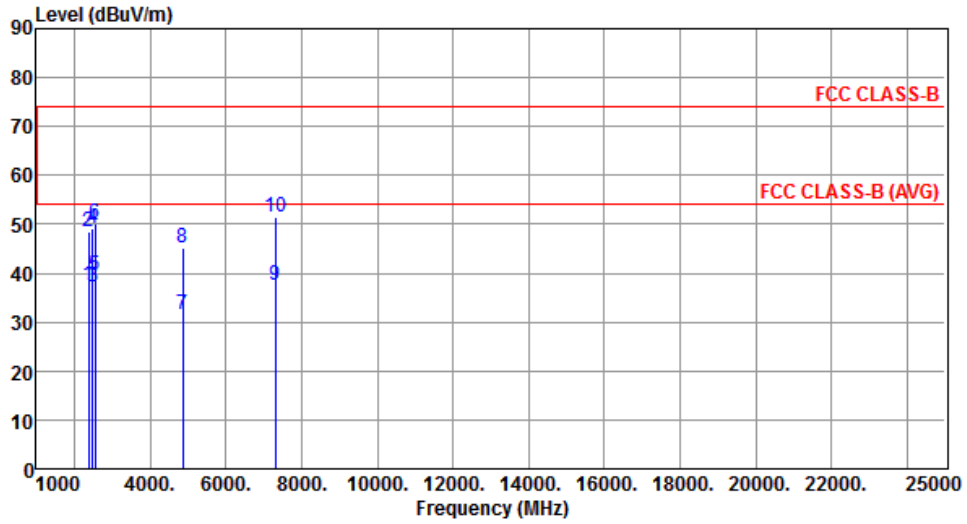

	Freq. MHz	Emission level dBuV/m	Limit dBuV/m	Margin dB	SA reading dBuV	Factor dB	Remark	ANT High cm	Turn Table deg
1	2390.00	37.51	54.00	-16.49	38.47	-0.96	Average	100	334
2	2390.00	48.51	74.00	-25.49	49.47	-0.96	Peak	100	334
3	2483.50	37.35	54.00	-16.65	38.47	-1.12	Average	100	334
4	2483.50	49.13	74.00	-24.87	50.25	-1.12	Peak	100	334
5	2560.00	39.38	54.00	-14.62	40.55	-1.17	Average	100	334
6	2560.00	50.23	74.00	-23.77	51.40	-1.17	Peak	100	334
7	4874.00	31.65	54.00	-22.35	26.74	4.91	Average	100	34
8	4874.00	45.18	74.00	-28.82	40.27	4.91	Peak	100	34
9	7311.00	37.46	54.00	-16.54	27.11	10.35	Average	100	53
10	7311.00	51.51	74.00	-22.49	41.16	10.35	Peak	100	53

Note 1: Emission Level (dBuV/m) = SA Reading (dBuV/m) + Factor* (dB)

*Factor includes antenna factor , cable loss and amplifier gain

Note 2: Margin (dB) = Emission level (dBuV/m) – Limit (dBuV/m).

Modulation	11b	Test Freq. (MHz)	2437
Polarization	Vertical	Test Configuration	2

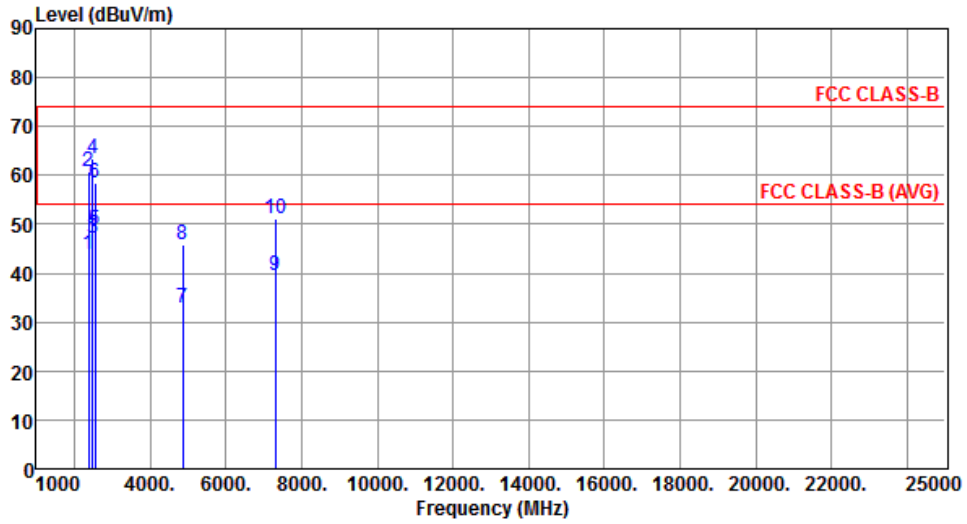

	Freq. MHz	Emission level dBuV/m	Limit dBuV/m	Margin dB	SA reading dBuV	Factor dB	Remark	ANT High cm	Turn Table deg
1	2390.00	43.75	54.00	-10.25	44.71	-0.96	Average	190	261
2	2390.00	60.85	74.00	-13.15	61.81	-0.96	Peak	190	261
3	2483.50	47.29	54.00	-6.71	48.41	-1.12	Average	190	261
4	2483.50	63.57	74.00	-10.43	64.69	-1.12	Peak	190	261
5	2560.00	48.71	54.00	-5.29	49.88	-1.17	Average	190	261
6	2560.00	58.54	74.00	-15.46	59.71	-1.17	Peak	190	261
7	4874.00	32.90	54.00	-21.10	27.99	4.91	Average	100	38
8	4874.00	45.99	74.00	-28.01	41.08	4.91	Peak	100	38
9	7311.00	39.41	54.00	-14.59	29.06	10.35	Average	100	52
10	7311.00	51.07	74.00	-22.93	40.72	10.35	Peak	100	52

Note 1: Emission Level (dBuV/m) = SA Reading (dBuV/m) + Factor* (dB)

*Factor includes antenna factor , cable loss and amplifier gain

Note 2: Margin (dB) = Emission level (dBuV/m) – Limit (dBuV/m).

Modulation	11b	Test Freq. (MHz)	2462
Polarization	Horizontal	Test Configuration	2

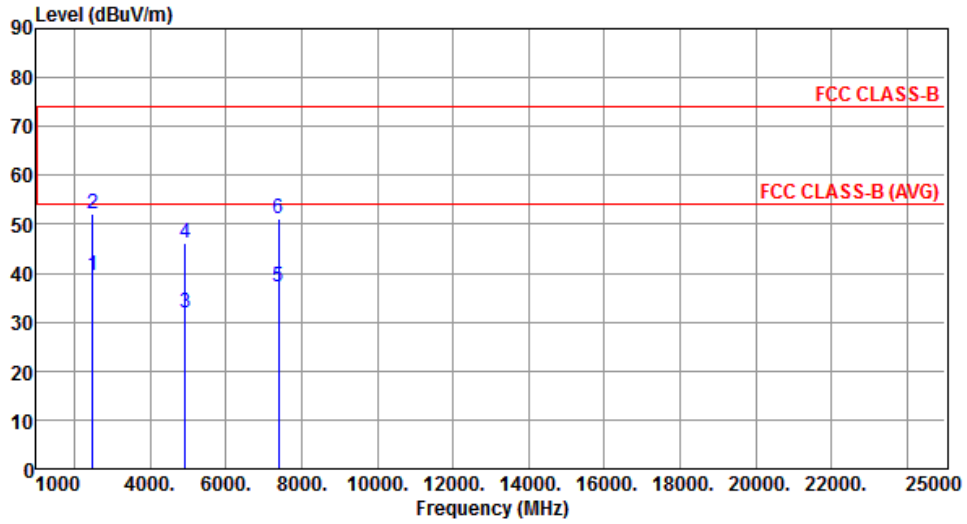

	Freq. MHz	Emission level dBuV/m	Limit dBuV/m	Margin dB	SA reading dBuV	Factor dB	Remark	ANT High cm	Turn Table deg
1	2483.50	39.56	54.00	-14.44	40.68	-1.12	Average	100	335
2	2483.50	52.05	74.00	-21.95	53.17	-1.12	Peak	100	335
3	4924.00	31.83	54.00	-22.17	26.82	5.01	Average	100	35
4	4924.00	46.11	74.00	-27.89	41.10	5.01	Peak	100	35
5	7386.00	37.03	54.00	-16.97	26.88	10.15	Average	100	57
6	7386.00	51.03	74.00	-22.97	40.88	10.15	Peak	100	57

Note 1: Emission Level (dBuV/m) = SA Reading (dBuV/m) + Factor* (dB)

*Factor includes antenna factor , cable loss and amplifier gain

Note 2: Margin (dB) = Emission level (dBuV/m) – Limit (dBuV/m).

Modulation	11b	Test Freq. (MHz)	2462
Polarization	Vertical	Test Configuration	2

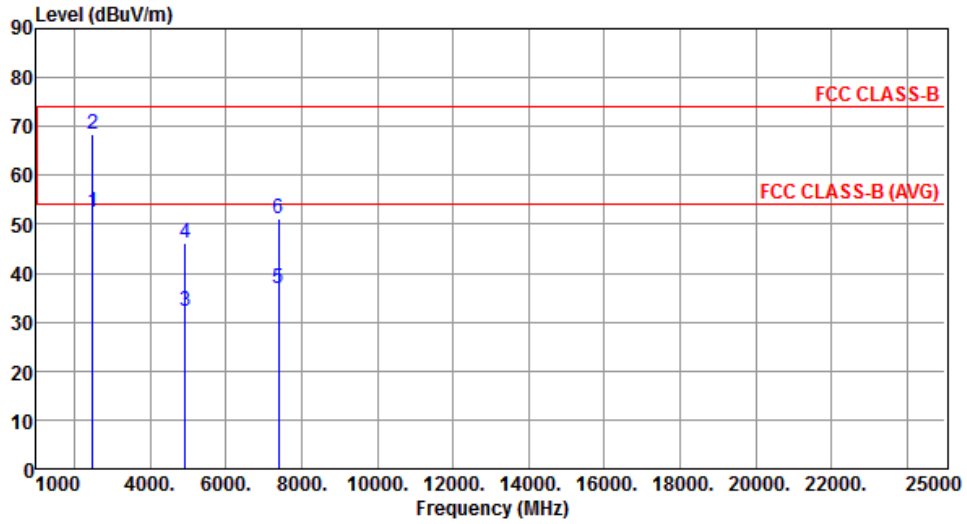

	Freq. MHz	Emission level dBuV/m	Limit dBuV/m	Margin dB	SA reading dBuV	Factor dB	Remark	ANT High cm	Turn Table deg
1	2483.50	52.62	54.00	-1.38	53.74	-1.12	Average	165	264
2	2483.50	68.35	74.00	-5.65	69.47	-1.12	Peak	165	264
3	4924.00	32.29	54.00	-21.71	27.28	5.01	Average	100	38
4	4924.00	46.03	74.00	-27.97	41.02	5.01	Peak	100	38
5	7386.00	36.86	54.00	-17.14	26.71	10.15	Average	100	52
6	7386.00	51.17	74.00	-22.83	41.02	10.15	Peak	100	52

Note 1: Emission Level (dBuV/m) = SA Reading (dBuV/m) + Factor* (dB)

*Factor includes antenna factor , cable loss and amplifier gain

Note 2: Margin (dB) = Emission level (dBuV/m) – Limit (dBuV/m).

3.5.6 Transmitter Radiated Unwanted Emissions (Above 1GHz) for 11g

Modulation	11g	Test Freq. (MHz)	2412
Polarization	Horizontal	Test Configuration	2

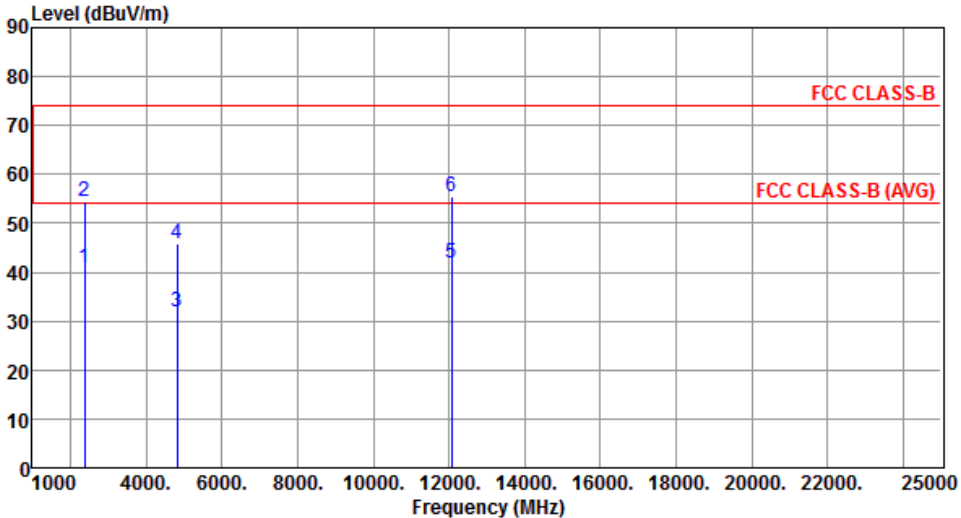

	Freq. MHz	Emission level dBuV/m	Limit dBuV/m	Margin dB	SA reading dBuV	Factor dB	Remark	ANT High cm	Turn Table deg
1	2390.00	40.80	54.00	-13.20	41.76	-0.96	Average	100	205
2	2390.00	54.57	74.00	-19.43	55.53	-0.96	Peak	100	205
3	4824.00	31.97	54.00	-22.03	27.10	4.87	Average	100	58
4	4824.00	45.83	74.00	-28.17	40.96	4.87	Peak	100	58
5	12060.00	41.86	54.00	-12.14	26.94	14.92	Average	100	58
6	12060.00	55.60	74.00	-18.40	40.68	14.92	Peak	100	58

Note 1: Emission Level (dBuV/m) = SA Reading (dBuV/m) + Factor* (dB)
*Factor includes antenna factor , cable loss and amplifier gain
Note 2: Margin (dB) = Emission level (dBuV/m) – Limit (dBuV/m).

Modulation	11g	Test Freq. (MHz)	2412
Polarization	Vertical	Test Configuration	2

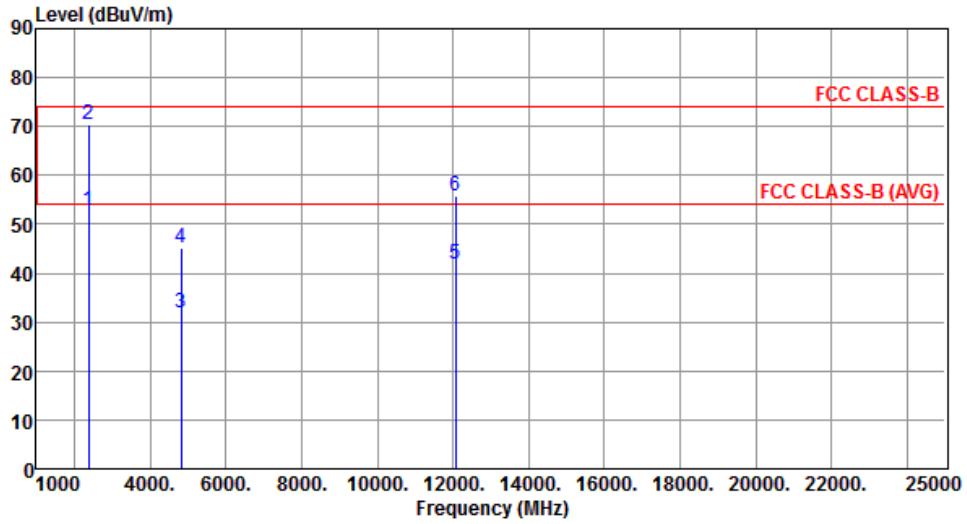

	Freq. MHz	Emission level dBuV/m	Limit dBuV/m	Margin dB	SA reading dBuV	Factor dB	Remark	ANT High cm	Turn Table deg
1	2390.00	52.95	54.00	-1.05	53.91	-0.96	Average	166	277
2	2390.00	70.30	74.00	-3.70	71.26	-0.96	Peak	166	277
3	4824.00	31.91	54.00	-22.09	27.04	4.87	Average	100	35
4	4824.00	45.10	74.00	-28.90	40.23	4.87	Peak	100	35
5	12060.00	41.96	54.00	-12.04	27.04	14.92	Average	100	58
6	12060.00	55.63	74.00	-18.37	40.71	14.92	Peak	100	58

Note 1: Emission Level (dBuV/m) = SA Reading (dBuV/m) + Factor* (dB)

*Factor includes antenna factor , cable loss and amplifier gain

Note 2: Margin (dB) = Emission level (dBuV/m) – Limit (dBuV/m).

Modulation	11g	Test Freq. (MHz)	2437
Polarization	Horizontal	Test Configuration	2

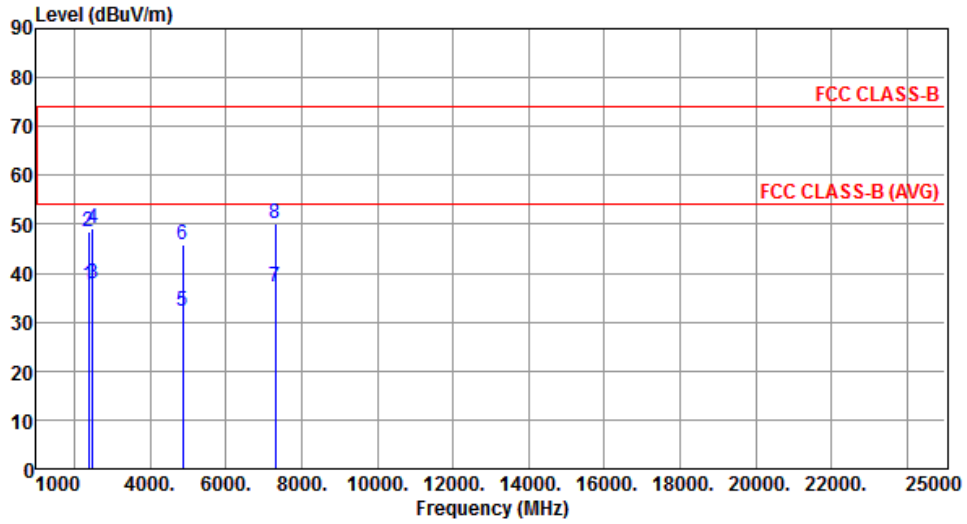

	Freq. MHz	Emission level dBuV/m	Limit dBuV/m	Margin dB	SA reading dBuV	Factor dB	Remark	ANT High cm	Turn Table deg
1	2390.00	37.51	54.00	-16.49	38.47	-0.96	Average	349	319
2	2390.00	48.51	74.00	-25.49	49.47	-0.96	Peak	349	319
3	2483.50	37.78	54.00	-16.22	38.90	-1.12	Average	349	319
4	2483.50	49.17	74.00	-24.83	50.29	-1.12	Peak	349	319
5	4874.00	32.16	54.00	-21.84	27.25	4.91	Average	100	36
6	4874.00	45.97	74.00	-28.03	41.06	4.91	Peak	100	36
7	7311.00	37.30	54.00	-16.70	26.95	10.35	Average	100	59
8	7311.00	50.29	74.00	-23.71	39.94	10.35	Peak	100	59

Note 1: Emission Level (dBuV/m) = SA Reading (dBuV/m) + Factor* (dB)

*Factor includes antenna factor , cable loss and amplifier gain

Note 2: Margin (dB) = Emission level (dBuV/m) – Limit (dBuV/m).

Modulation	11g	Test Freq. (MHz)	2437
Polarization	Vertical	Test Configuration	2

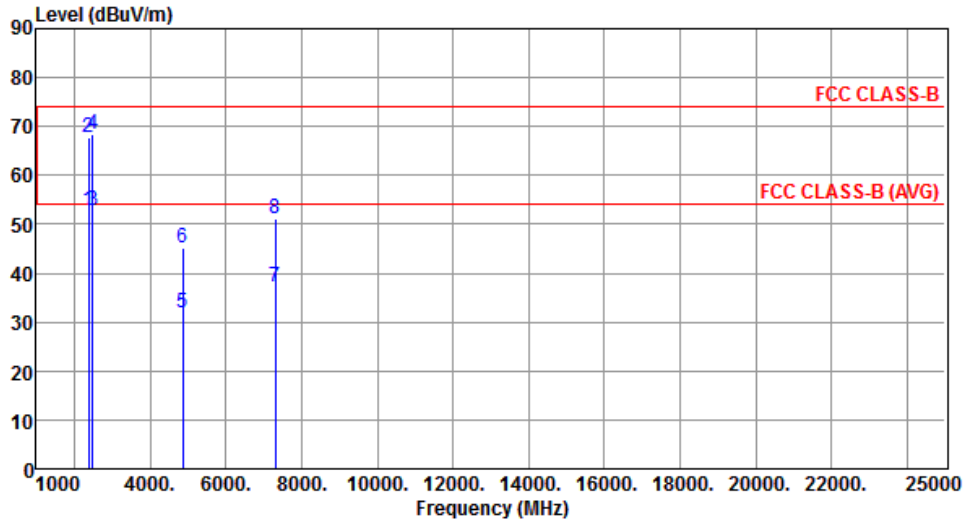

	Freq. MHz	Emission level dBuV/m	Limit dBuV/m	Margin dB	SA reading dBuV	Factor dB	Remark	ANT High cm	Turn Table deg
1	2390.00	52.78	54.00	-1.22	53.74	-0.96	Average	110	315
2	2390.00	67.68	74.00	-6.32	68.64	-0.96	Peak	110	315
3	2483.50	52.70	54.00	-1.30	53.82	-1.12	Average	110	315
4	2483.50	68.31	74.00	-5.69	69.43	-1.12	Peak	110	315
5	4874.00	32.01	54.00	-21.99	27.10	4.91	Average	100	36
6	4874.00	45.18	74.00	-28.82	40.27	4.91	Peak	100	36
7	7311.00	37.29	54.00	-16.71	26.94	10.35	Average	100	53
8	7311.00	51.12	74.00	-22.88	40.77	10.35	Peak	100	53

Note 1: Emission Level (dBuV/m) = SA Reading (dBuV/m) + Factor* (dB)

*Factor includes antenna factor , cable loss and amplifier gain

Note 2: Margin (dB) = Emission level (dBuV/m) – Limit (dBuV/m).

Modulation	11g	Test Freq. (MHz)	2462
Polarization	Horizontal	Test Configuration	2

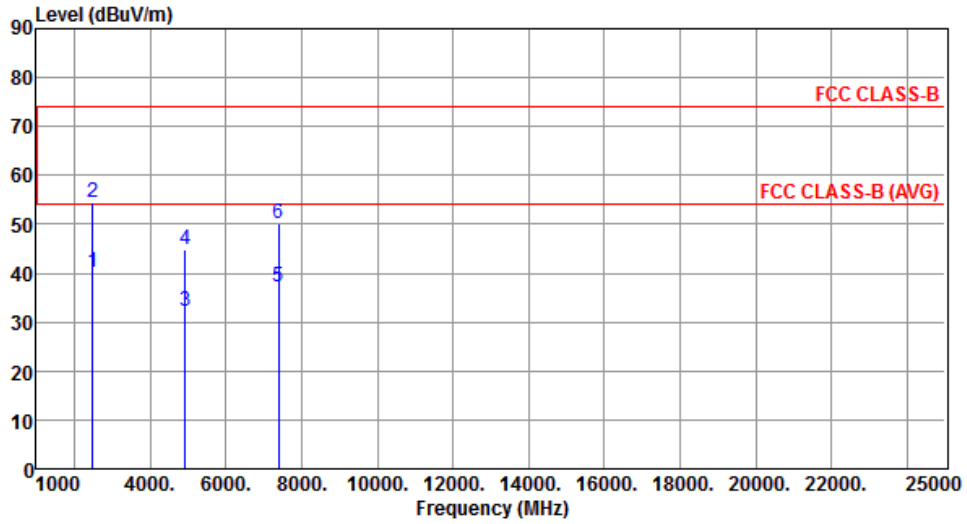

	Freq. MHz	Emission level dBuV/m	Limit dBuV/m	Margin dB	SA reading dBuV	Factor dB	Remark	ANT High cm	Turn Table deg
1	2483.50	40.28	54.00	-13.72	41.40	-1.12	Average	100	212
2	2483.50	54.63	74.00	-19.37	55.75	-1.12	Peak	100	212
3	4924.00	32.07	54.00	-21.93	27.06	5.01	Average	100	32
4	4924.00	44.96	74.00	-29.04	39.95	5.01	Peak	100	32
5	7386.00	37.15	54.00	-16.85	27.00	10.15	Average	100	51
6	7386.00	50.10	74.00	-23.90	39.95	10.15	Peak	100	51

Note 1: Emission Level (dBuV/m) = SA Reading (dBuV/m) + Factor* (dB)

*Factor includes antenna factor , cable loss and amplifier gain

Note 2: Margin (dB) = Emission level (dBuV/m) – Limit (dBuV/m).

Modulation	11g	Test Freq. (MHz)	2462
Polarization	Vertical	Test Configuration	2

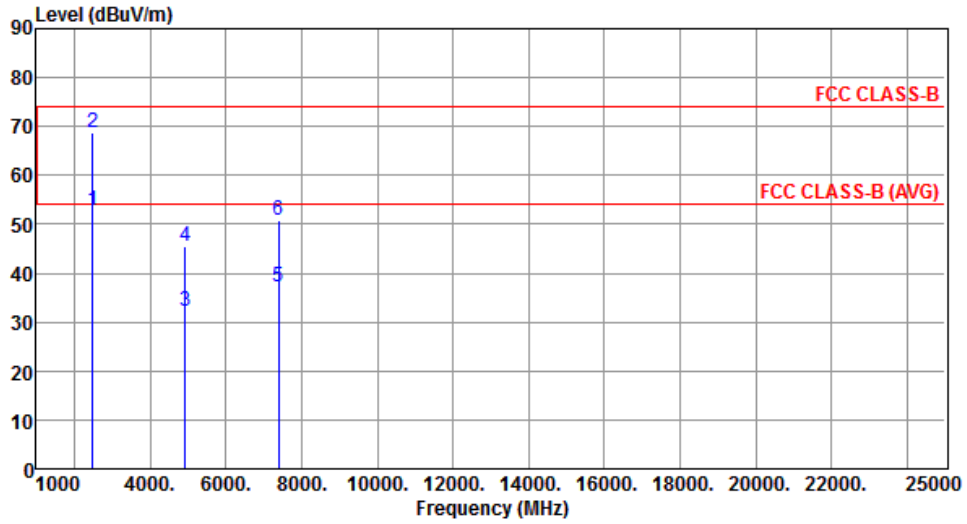

	Freq. MHz	Emission level dBuV/m	Limit dBuV/m	Margin dB	SA reading dBuV	Factor dB	Remark	ANT High cm	Turn Table deg
1	2483.50	52.92	54.00	-1.08	54.04	-1.12	Average	129	315
2	2483.50	68.83	74.00	-5.17	69.95	-1.12	Peak	129	315
3	4924.00	32.13	54.00	-21.87	27.12	5.01	Average	100	33
4	4924.00	45.60	74.00	-28.40	40.59	5.01	Peak	100	33
5	7386.00	37.32	54.00	-16.68	27.17	10.15	Average	100	49
6	7386.00	50.78	74.00	-23.22	40.63	10.15	Peak	100	49

Note 1: Emission Level (dBuV/m) = SA Reading (dBuV/m) + Factor* (dB)

*Factor includes antenna factor , cable loss and amplifier gain

Note 2: Margin (dB) = Emission level (dBuV/m) – Limit (dBuV/m).

3.5.7 Transmitter Radiated Unwanted Emissions (Above 1GHz) for HT20

Modulation	HT20	Test Freq. (MHz)	2412
Polarization	Horizontal	Test Configuration	2

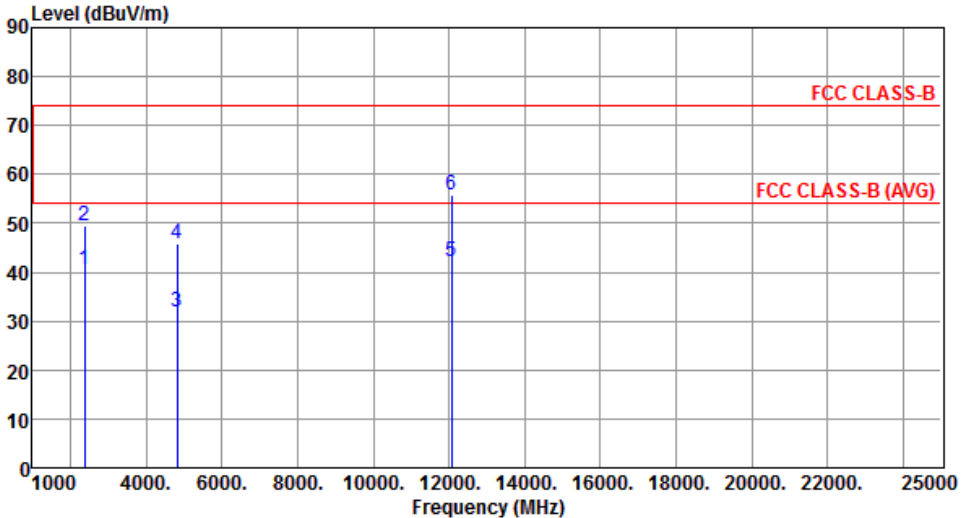

	Freq. MHz	Emission level dBuV/m	Limit dBuV/m	Margin dB	SA reading dBuV	Factor dB	Remark	ANT High cm	Turn Table deg
1	2390.00	40.50	54.00	-13.50	41.46	-0.96	Average	102	228
2	2390.00	49.52	74.00	-24.48	50.48	-0.96	Peak	102	228
3	4824.00	31.94	54.00	-22.06	27.07	4.87	Average	100	29
4	4824.00	45.94	74.00	-28.06	41.07	4.87	Peak	100	29
5	12060.00	42.02	54.00	-11.98	27.10	14.92	Average	100	49
6	12060.00	55.85	74.00	-18.15	40.93	14.92	Peak	100	49

Note 1: Emission Level (dBuV/m) = SA Reading (dBuV/m) + Factor* (dB)
*Factor includes antenna factor , cable loss and amplifier gain
Note 2: Margin (dB) = Emission level (dBuV/m) – Limit (dBuV/m).

Modulation	HT20	Test Freq. (MHz)	2412
Polarization	Vertical	Test Configuration	2

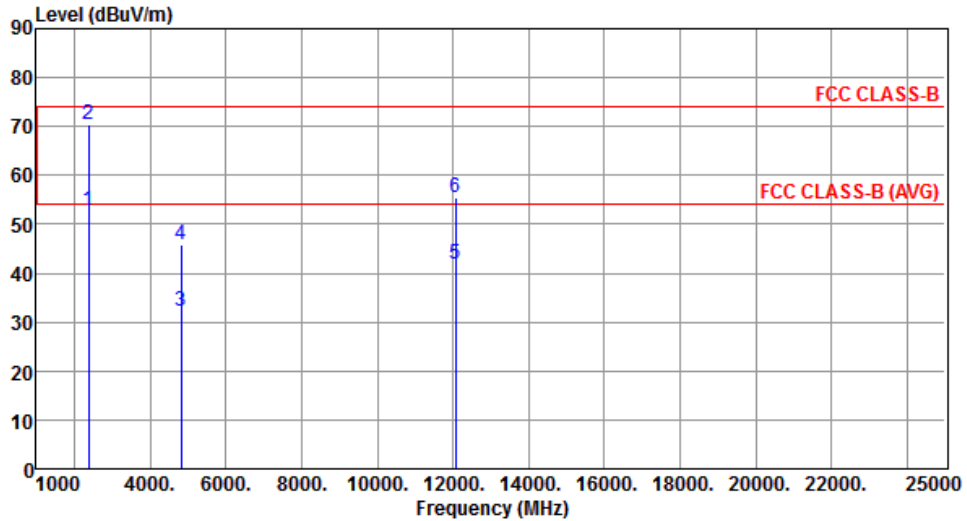

	Freq. MHz	Emission level dBuV/m	Limit dBuV/m	Margin dB	SA reading dBuV	Factor dB	Remark	ANT High cm	Turn Table deg
1	2390.00	52.76	54.00	-1.24	53.72	-0.96	Average	170	298
2	2390.00	70.30	74.00	-3.70	71.26	-0.96	Peak	170	298
3	4824.00	32.08	54.00	-21.92	27.21	4.87	Average	100	35
4	4824.00	45.81	74.00	-28.19	40.94	4.87	Peak	100	35
5	12060.00	41.93	54.00	-12.07	27.01	14.92	Average	100	57
6	12060.00	55.38	74.00	-18.62	40.46	14.92	Peak	100	57

Note 1: Emission Level (dBuV/m) = SA Reading (dBuV/m) + Factor* (dB)

*Factor includes antenna factor , cable loss and amplifier gain

Note 2: Margin (dB) = Emission level (dBuV/m) – Limit (dBuV/m).

Modulation	HT20	Test Freq. (MHz)	2437
Polarization	Horizontal	Test Configuration	2

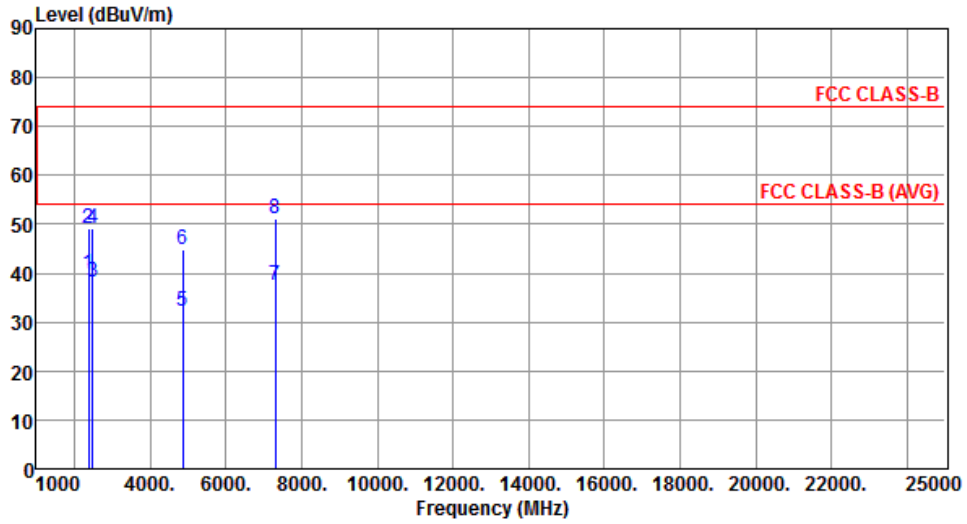

	Freq. MHz	Emission level dBuV/m	Limit dBuV/m	Margin dB	SA reading dBuV	Factor dB	Remark	ANT High cm	Turn Table deg
1	2390.00	39.73	54.00	-14.27	40.69	-0.96	Average	114	223
2	2390.00	49.13	74.00	-24.87	50.09	-0.96	Peak	114	223
3	2483.50	38.05	54.00	-15.95	39.17	-1.12	Average	114	223
4	2483.50	49.12	74.00	-24.88	50.24	-1.12	Peak	114	223
5	4874.00	32.08	54.00	-21.92	27.17	4.91	Average	100	32
6	4874.00	44.85	74.00	-29.15	39.94	4.91	Peak	100	32
7	7311.00	37.42	54.00	-16.58	27.07	10.35	Average	100	52
8	7311.00	51.29	74.00	-22.71	40.94	10.35	Peak	100	52

Note 1: Emission Level (dBuV/m) = SA Reading (dBuV/m) + Factor* (dB)

*Factor includes antenna factor , cable loss and amplifier gain

Note 2: Margin (dB) = Emission level (dBuV/m) – Limit (dBuV/m).

Modulation	HT20	Test Freq. (MHz)	2437
Polarization	Vertical	Test Configuration	2

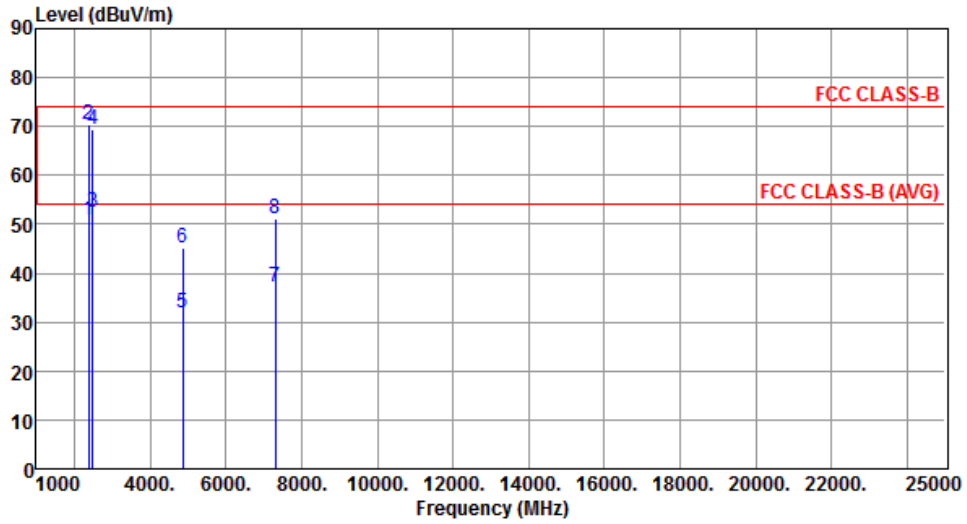

	Freq. MHz	Emission level dBuV/m	Limit dBuV/m	Margin dB	SA reading dBuV	Factor dB	Remark	ANT High cm	Turn Table deg
1	2390.00	50.85	54.00	-3.15	51.81	-0.96	Average	100	274
2	2390.00	70.49	74.00	-3.51	71.45	-0.96	Peak	100	274
3	2483.50	52.40	54.00	-1.60	53.52	-1.12	Average	174	258
4	2483.50	69.25	74.00	-4.75	70.37	-1.12	Peak	174	258
5	4874.00	31.74	54.00	-22.26	26.83	4.91	Average	100	37
6	4874.00	45.17	74.00	-28.83	40.26	4.91	Peak	100	37
7	7311.00	37.23	54.00	-16.77	26.88	10.35	Average	100	57
8	7311.00	51.15	74.00	-22.85	40.80	10.35	Peak	100	57

Note 1: Emission Level (dBuV/m) = SA Reading (dBuV/m) + Factor* (dB)

*Factor includes antenna factor , cable loss and amplifier gain

Note 2: Margin (dB) = Emission level (dBuV/m) – Limit (dBuV/m).

Modulation	HT20	Test Freq. (MHz)	2462
Polarization	Horizontal	Test Configuration	2

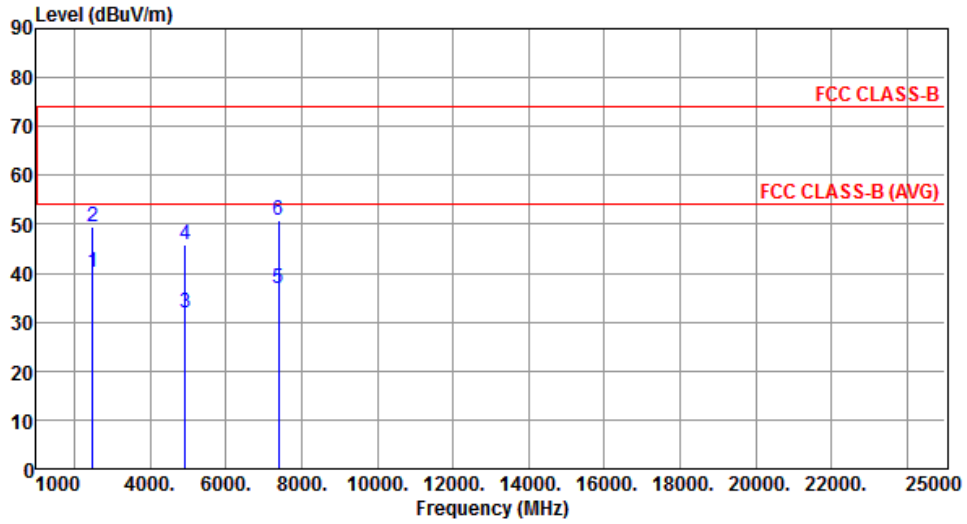

	Freq. MHz	Emission level dBuV/m	Limit dBuV/m	Margin dB	SA reading dBuV	Factor dB	Remark	ANT High cm	Turn Table deg
1	2483.50	40.35	54.00	-13.65	41.47	-1.12	Average	100	244
2	2483.50	49.36	74.00	-24.64	50.48	-1.12	Peak	100	244
3	4924.00	31.90	54.00	-22.10	26.89	5.01	Average	100	33
4	4924.00	45.99	74.00	-28.01	40.98	5.01	Peak	100	33
5	7386.00	36.96	54.00	-17.04	26.81	10.15	Average	100	52
6	7386.00	50.91	74.00	-23.09	40.76	10.15	Peak	100	52

Note 1: Emission Level (dBuV/m) = SA Reading (dBuV/m) + Factor* (dB)

*Factor includes antenna factor , cable loss and amplifier gain

Note 2: Margin (dB) = Emission level (dBuV/m) – Limit (dBuV/m).

Modulation	HT20	Test Freq. (MHz)	2462
Polarization	Vertical	Test Configuration	2

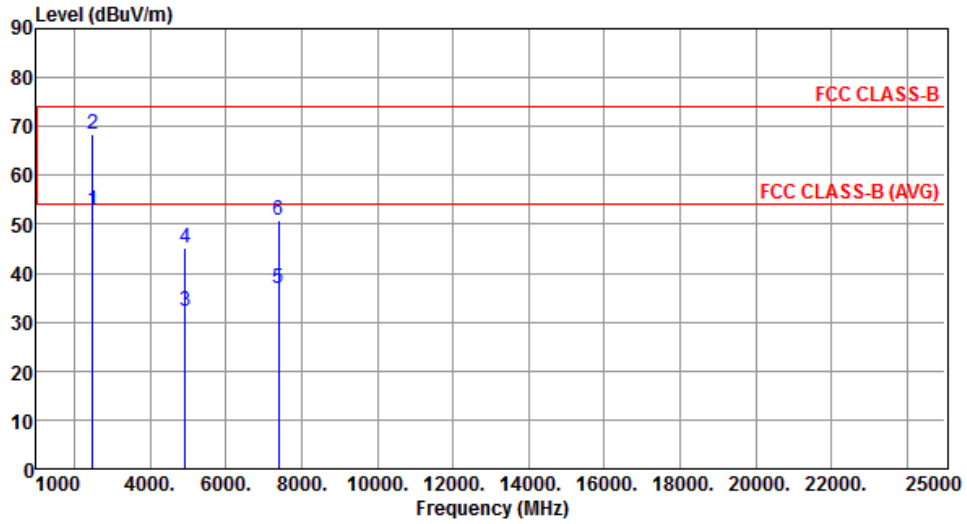

	Freq. MHz	Emission level dBuV/m	Limit dBuV/m	Margin dB	SA reading dBuV	Factor dB	Remark	ANT High cm	Turn Table deg
1	2483.50	52.68	54.00	-1.32	53.80	-1.12	Average	158	292
2	2483.50	68.29	74.00	-5.71	69.41	-1.12	Peak	158	292
3	4924.00	32.35	54.00	-21.65	27.34	5.01	Average	100	37
4	4924.00	45.29	74.00	-28.71	40.28	5.01	Peak	100	37
5	7386.00	36.86	54.00	-17.14	26.71	10.15	Average	100	52
6	7386.00	50.79	74.00	-23.21	40.64	10.15	Peak	100	52

Note 1: Emission Level (dBuV/m) = SA Reading (dBuV/m) + Factor* (dB)

*Factor includes antenna factor , cable loss and amplifier gain

Note 2: Margin (dB) = Emission level (dBuV/m) – Limit (dBuV/m).

3.5.8 Transmitter Radiated Unwanted Emissions (Above 1GHz) for HT40

Modulation	HT40	Test Freq. (MHz)	2422
Polarization	Horizontal	Test Configuration	2

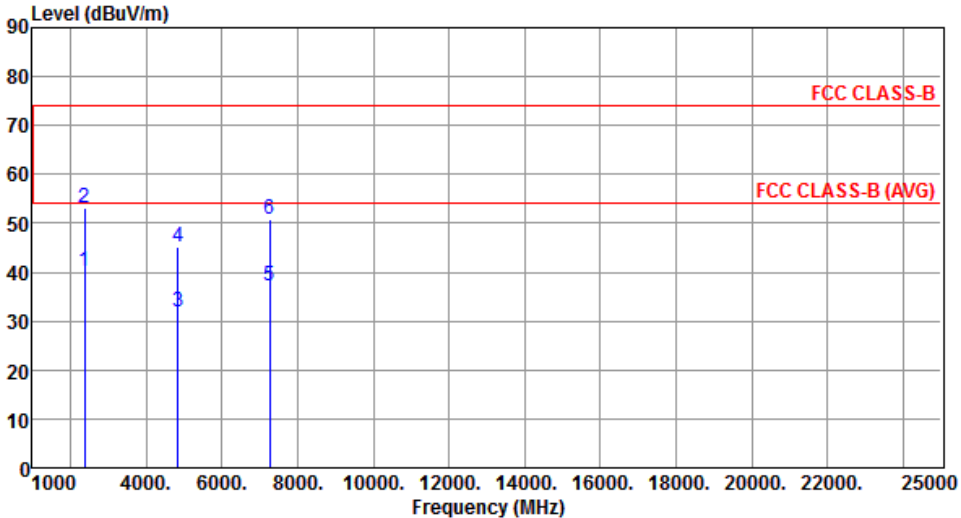

	Freq. MHz	Emission level dBuV/m	Limit dBuV/m	Margin dB	SA reading dBuV	Factor dB	Remark	ANT High cm	Turn Table deg
1	2390.00	40.09	54.00	-13.91	41.05	-0.96	Average	100	223
2	2390.00	53.07	74.00	-20.93	54.03	-0.96	Peak	100	223
3	4844.00	31.90	54.00	-22.10	26.97	4.93	Average	100	37
4	4844.00	45.13	74.00	-28.87	40.20	4.93	Peak	100	37
5	7266.00	37.22	54.00	-16.78	26.82	10.40	Average	100	53
6	7266.00	50.75	74.00	-23.25	40.35	10.40	Peak	100	53

Note 1: Emission Level (dBuV/m) = SA Reading (dBuV/m) + Factor* (dB)
*Factor includes antenna factor , cable loss and amplifier gain
Note 2: Margin (dB) = Emission level (dBuV/m) – Limit (dBuV/m).

Modulation	HT40	Test Freq. (MHz)	2422
Polarization	Vertical	Test Configuration	2

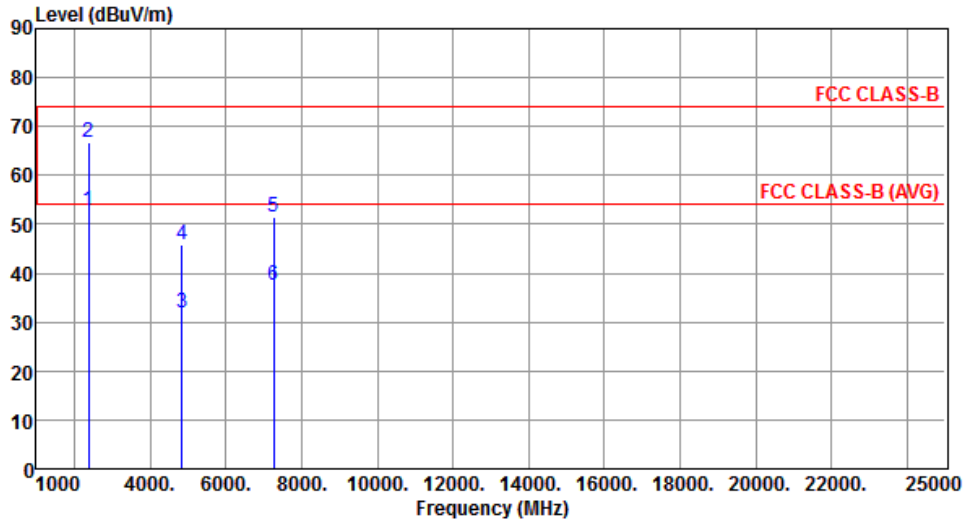

	Freq. MHz	Emission level dBuV/m	Limit dBuV/m	Margin dB	SA reading dBuV	Factor dB	Remark	ANT High cm	Turn Table deg
1	2390.00	52.72	54.00	-1.28	53.68	-0.96	Average	163	268
2	2390.00	66.82	74.00	-7.18	67.78	-0.96	Peak	163	268
3	4844.00	32.03	54.00	-21.97	27.10	4.93	Average	100	38
4	4844.00	45.90	74.00	-28.10	40.97	4.93	Peak	100	38
5	7266.00	51.38	74.00	-22.62	40.98	10.40	Peak	100	54
6	7266.00	37.51	74.00	-36.49	27.11	10.40	Peak	100	54

Note 1: Emission Level (dBuV/m) = SA Reading (dBuV/m) + Factor* (dB)

*Factor includes antenna factor , cable loss and amplifier gain

Note 2: Margin (dB) = Emission level (dBuV/m) – Limit (dBuV/m).

Modulation	HT40	Test Freq. (MHz)	2437
Polarization	Horizontal	Test Configuration	2

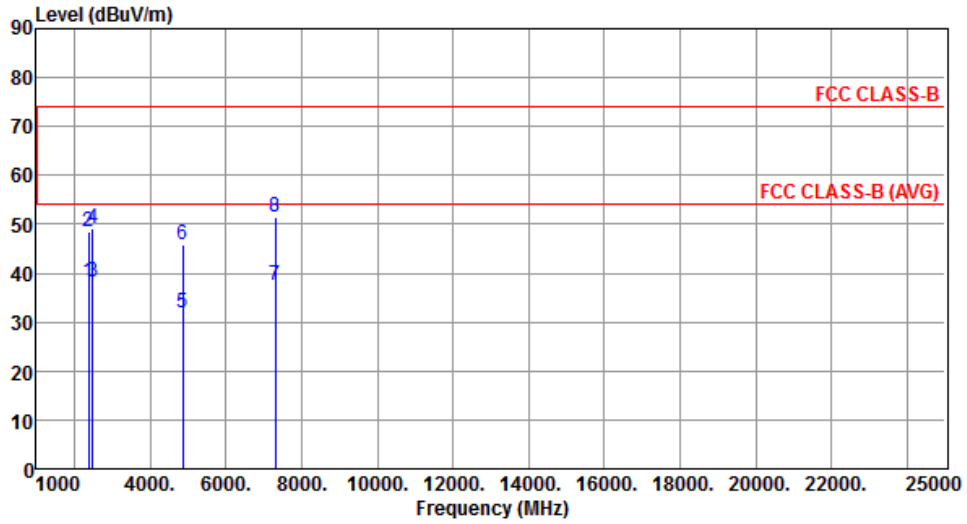

	Freq. MHz	Emission level dBuV/m	Limit dBuV/m	Margin dB	SA reading dBuV	Factor dB	Remark	ANT High cm	Turn Table deg
1	2390.00	38.14	54.00	-15.86	39.10	-0.96	Average	100	225
2	2390.00	48.51	74.00	-25.49	49.47	-0.96	Peak	100	225
3	2483.50	38.09	54.00	-15.91	39.21	-1.12	Average	100	225
4	2483.50	49.08	74.00	-24.92	50.20	-1.12	Peak	100	225
5	4874.00	32.04	54.00	-21.96	27.13	4.91	Average	100	33
6	4874.00	45.94	74.00	-28.06	41.03	4.91	Peak	100	33
7	7311.00	37.42	54.00	-16.58	27.07	10.35	Average	100	55
8	7311.00	51.39	74.00	-22.61	41.04	10.35	Peak	100	55

Note 1: Emission Level (dBuV/m) = SA Reading (dBuV/m) + Factor* (dB)

*Factor includes antenna factor , cable loss and amplifier gain

Note 2: Margin (dB) = Emission level (dBuV/m) – Limit (dBuV/m).

Modulation	HT40	Test Freq. (MHz)	2437
Polarization	Vertical	Test Configuration	2

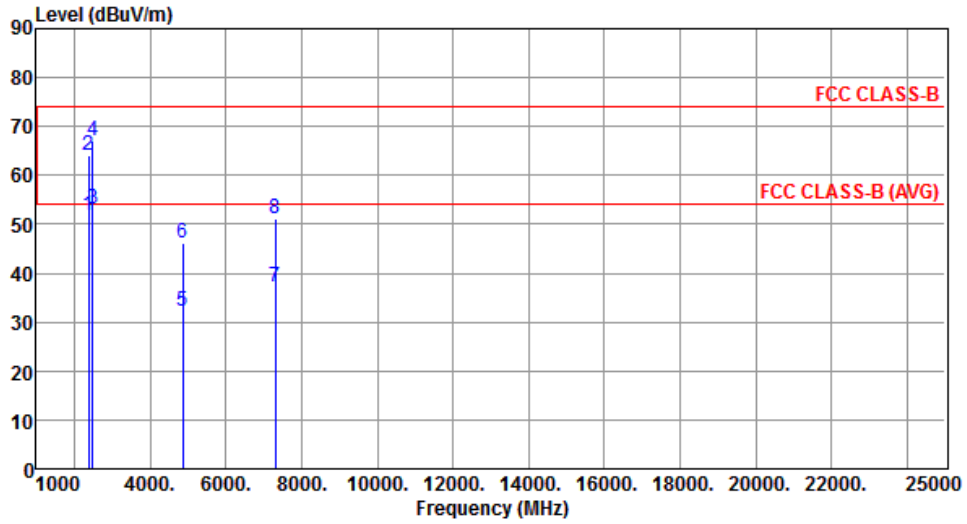

	Freq. MHz	Emission level dBuV/m	Limit dBuV/m	Margin dB	SA reading dBuV	Factor dB	Remark	ANT High cm	Turn Table deg
1	2390.00	51.78	54.00	-2.22	52.74	-0.96	Average	170	229
2	2390.00	64.19	74.00	-9.81	65.15	-0.96	Peak	170	229
3	2483.50	52.97	54.00	-1.03	54.09	-1.12	Average	131	312
4	2483.50	67.18	74.00	-6.82	68.30	-1.12	Peak	131	312
5	4874.00	32.26	54.00	-21.74	27.35	4.91	Average	100	32
6	4874.00	46.15	74.00	-27.85	41.24	4.91	Peak	100	32
7	7311.00	37.15	54.00	-16.85	26.80	10.35	Average	100	52
8	7311.00	50.99	74.00	-23.01	40.64	10.35	Peak	100	52

Note 1: Emission Level (dBuV/m) = SA Reading (dBuV/m) + Factor* (dB)

*Factor includes antenna factor , cable loss and amplifier gain

Note 2: Margin (dB) = Emission level (dBuV/m) – Limit (dBuV/m).

Modulation	HT40	Test Freq. (MHz)	2452
Polarization	Horizontal	Test Configuration	2

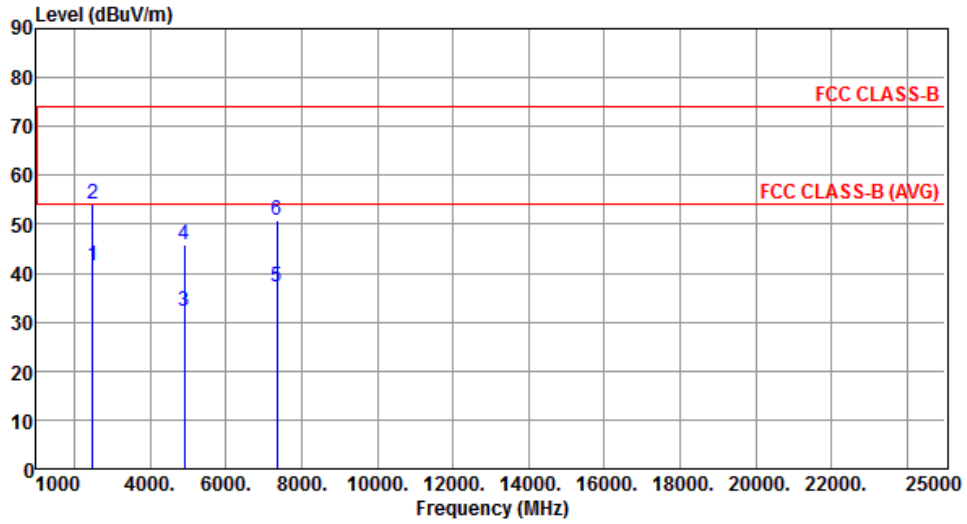

	Freq. MHz	Emission level dBuV/m	Limit dBuV/m	Margin dB	SA reading dBuV	Factor dB	Remark	ANT High cm	Turn Table deg
1	2483.50	41.36	54.00	-12.64	42.48	-1.12	Average	100	227
2	2483.50	53.99	74.00	-20.01	55.11	-1.12	Peak	100	227
3	4904.00	32.12	54.00	-21.88	27.21	4.91	Average	100	32
4	4904.00	45.93	74.00	-28.07	41.02	4.91	Peak	100	32
5	7356.00	37.10	54.00	-16.90	26.87	10.23	Average	100	57
6	7356.00	50.80	74.00	-23.20	40.57	10.23	Peak	100	57

Note 1: Emission Level (dBuV/m) = SA Reading (dBuV/m) + Factor* (dB)

*Factor includes antenna factor , cable loss and amplifier gain

Note 2: Margin (dB) = Emission level (dBuV/m) – Limit (dBuV/m).

Modulation	HT40	Test Freq. (MHz)	2452
Polarization	Vertical	Test Configuration	2

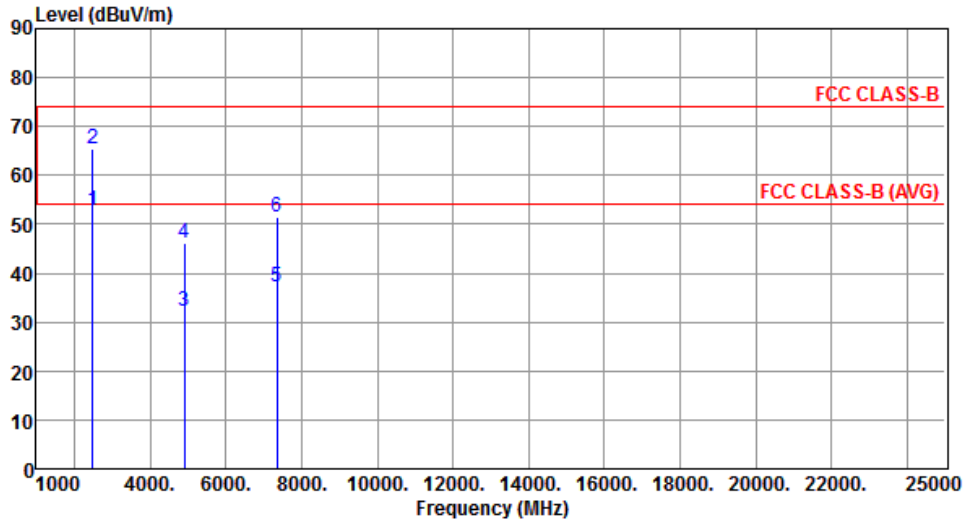

	Freq. MHz	Emission level dBuV/m	Limit dBuV/m	Margin dB	SA reading dBuV	Factor dB	Remark	ANT High cm	Turn Table deg
1	2483.50	52.67	54.00	-1.33	53.79	-1.12	Average	152	268
2	2483.50	65.32	74.00	-8.68	66.44	-1.12	Peak	152	268
3	4904.00	32.06	54.00	-21.94	27.15	4.91	Average	100	33
4	4904.00	46.15	74.00	-27.85	41.24	4.91	Peak	100	33
5	7356.00	37.14	54.00	-16.86	26.91	10.23	Average	100	53
6	7356.00	51.36	74.00	-22.64	41.13	10.23	Peak	100	53

Note 1: Emission Level (dBuV/m) = SA Reading (dBuV/m) + Factor* (dB)

*Factor includes antenna factor , cable loss and amplifier gain

Note 2: Margin (dB) = Emission level (dBuV/m) – Limit (dBuV/m).

Beamforming mode

3.5.9 Transmitter Radiated Unwanted Emissions (Below 1GHz)

Modulation	HT20	Test Freq. (MHz)	2437
Polarization	Horizontal	Test Configuration	1

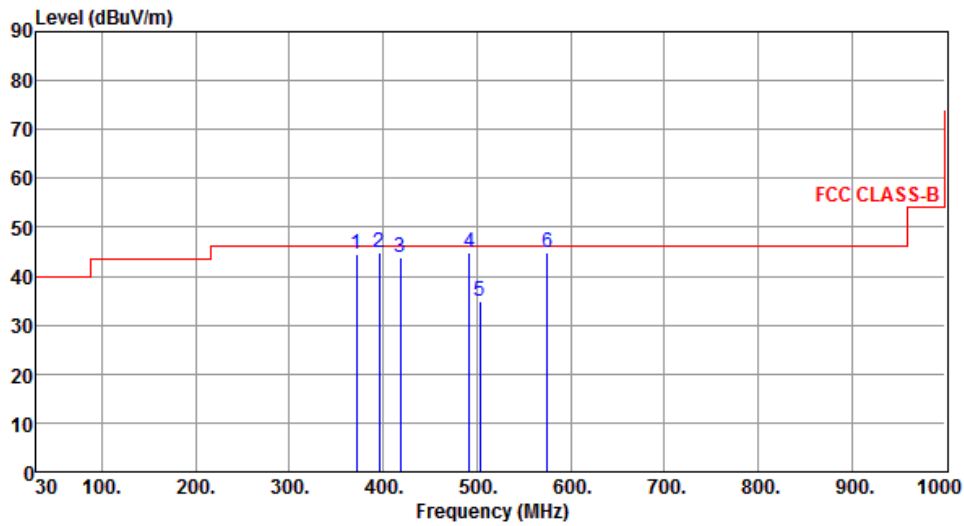

	Freq. MHz	Emission level dBuV/m	Limit dBuV/m	Margin dB	SA reading dBuV	Factor dB	Remark	ANT High cm	Turn Table deg
1	371.78	44.39	46.00	-1.61	50.11	-5.72	QP	100	119
2	395.75	44.88	46.00	-1.12	49.92	-5.04	QP	100	122
3	418.79	43.86	46.00	-2.14	48.30	-4.44	QP	100	125
4	491.75	44.69	46.00	-1.31	47.63	-2.94	QP	168	132
5	502.89	34.78	46.00	-11.22	37.53	-2.75	QP	185	57
6	575.33	44.68	46.00	-1.32	45.72	-1.04	QP	149	132

Note 1: Emission Level (dBuV/m) = SA Reading (dBuV/m) + Factor* (dB)

*Factor includes antenna factor , cable loss and amplifier gain

Note 2: Margin (dB) = Emission level (dBuV/m) – Limit (dBuV/m).

Note 3: All spurious emissions below 30MHz are more than 20 dB below the limit.

Modulation	HT20	Test Freq. (MHz)	2437
Polarization	Vertical	Test Configuration	1

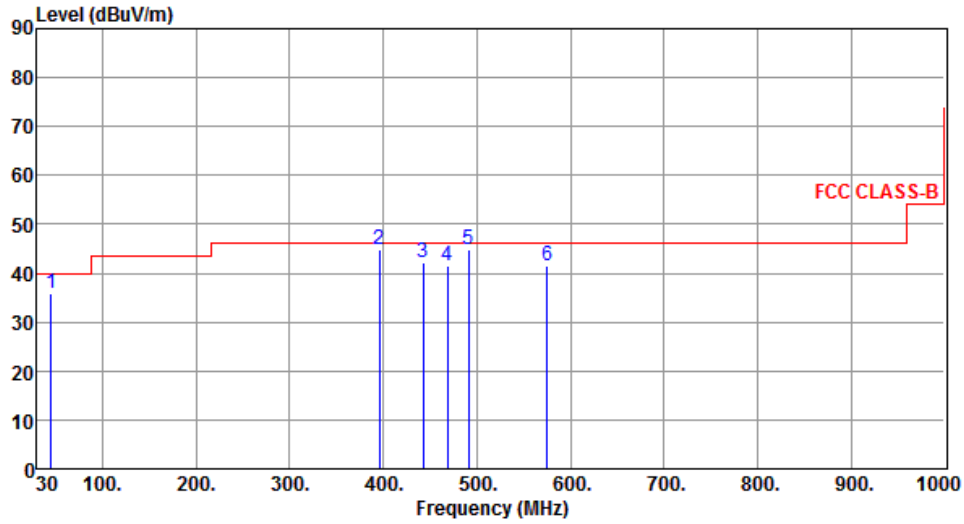

	Freq. MHz	Emission level dBuV/m	Limit dBuV/m	Margin dB	SA reading dBuV	Factor dB	Remark	ANT High cm	Turn Table deg
1	45.33	35.88	40.00	-4.12	43.98	-8.10	QP	100	120
2	396.21	44.79	46.00	-1.21	49.81	-5.02	QP	102	180
3	442.78	42.23	46.00	-3.77	46.05	-3.82	Peak	---	---
4	468.24	41.62	46.00	-4.38	44.94	-3.32	QP	100	123
5	491.49	44.75	46.00	-1.25	47.69	-2.94	QP	100	121
6	574.88	41.52	46.00	-4.48	42.57	-1.05	Peak	---	---

Note 1: Emission Level (dBuV/m) = SA Reading (dBuV/m) + Factor* (dB)

*Factor includes antenna factor , cable loss and amplifier gain

Note 2: Margin (dB) = Emission level (dBuV/m) – Limit (dBuV/m).

Note 3: All spurious emissions below 30MHz are more than 20 dB below the limit.

Modulation	HT20	Test Freq. (MHz)	2437
Polarization	Horizontal	Test Configuration	2

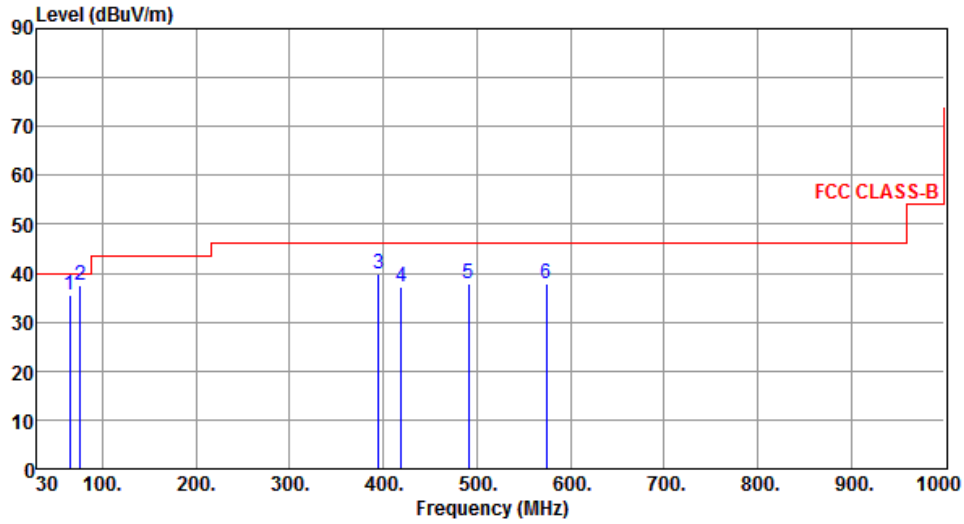

	Freq. MHz	Emission level dBuV/m	Limit dBuV/m	Margin dB	SA reading dBuV	Factor dB	Remark	ANT High cm	Turn Table deg
1	64.88	35.67	40.00	-4.33	45.24	-9.57	QP	100	62
2	76.39	37.68	40.00	-2.32	49.70	-12.02	QP	140	165
3	394.78	39.87	46.00	-6.13	44.94	-5.07	Peak	---	---
4	419.59	37.31	46.00	-8.69	41.73	-4.42	Peak	---	---
5	491.42	37.92	46.00	-8.08	40.86	-2.94	Peak	---	---
6	574.55	37.86	46.00	-8.14	38.92	-1.06	Peak	---	---

Note 1: Emission Level (dBuV/m) = SA Reading (dBuV/m) + Factor* (dB)

*Factor includes antenna factor , cable loss and amplifier gain

Note 2: Margin (dB) = Emission level (dBuV/m) – Limit (dBuV/m).

Note 3: All spurious emissions below 30MHz are more than 20 dB below the limit.

Modulation	HT20	Test Freq. (MHz)	2437
Polarization	Vertical	Test Configuration	2

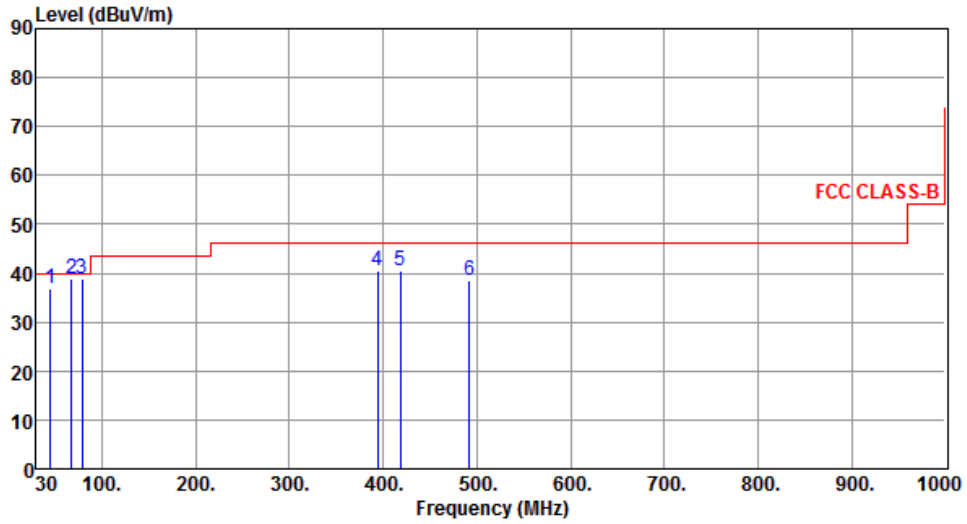

	Freq. MHz	Emission level dBuV/m	Limit dBuV/m	Margin dB	SA reading dBuV	Factor dB	Remark	ANT High cm	Turn Table deg
1	45.31	36.96	40.00	-3.04	45.06	-8.10	QP	100	100
2	67.52	38.92	40.00	-1.08	48.97	-10.05	QP	100	3
3	78.55	38.84	40.00	-1.16	51.34	-12.50	QP	165	183
4	394.42	40.62	46.00	-5.38	45.70	-5.08	Peak	---	---
5	418.58	40.53	46.00	-5.47	44.97	-4.44	Peak	---	---
6	492.31	38.52	46.00	-7.48	41.45	-2.93	Peak	---	---

Note 1: Emission Level (dBuV/m) = SA Reading (dBuV/m) + Factor* (dB)

*Factor includes antenna factor , cable loss and amplifier gain

Note 2: Margin (dB) = Emission level (dBuV/m) – Limit (dBuV/m).

Note 3: All spurious emissions below 30MHz are more than 20 dB below the limit.

3.5.10 Transmitter Radiated Unwanted Emissions (Above 1GHz) for HT20

Modulation	HT20	Test Freq. (MHz)	2412
Polarization	Horizontal	Test Configuration	2

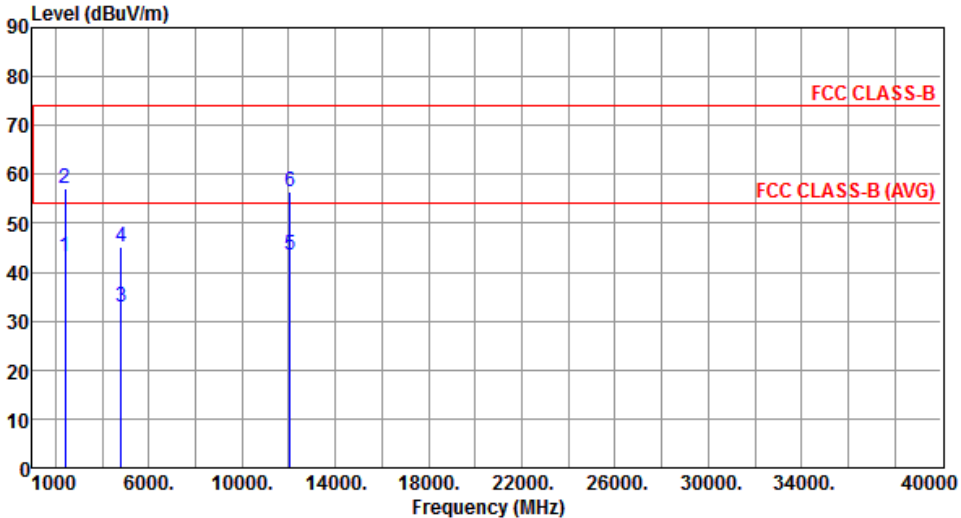

	Freq. MHz	Emission level dBuV/m	Limit dBuV/m	Margin dB	SA reading dBuV	Factor dB	Remark	ANT High cm	Turn Table deg
1	2390.00	43.16	54.00	-10.84	44.12	-0.96	Average	100	231
2	2390.00	57.28	74.00	-16.72	58.24	-0.96	Peak	100	231
3	4824.00	33.03	54.00	-20.97	28.16	4.87	Average	100	70
4	4824.00	45.32	74.00	-28.68	40.45	4.87	Peak	100	70
5	12060.00	43.67	54.00	-10.33	28.75	14.92	Average	100	60
6	12060.00	56.38	74.00	-17.62	41.46	14.92	Peak	100	60

Note 1: Emission Level (dBuV/m) = SA Reading (dBuV/m) + Factor* (dB)
*Factor includes antenna factor , cable loss and amplifier gain
Note 2: Margin (dB) = Emission level (dBuV/m) – Limit (dBuV/m).

Modulation	HT20	Test Freq. (MHz)	2412
Polarization	Vertical	Test Configuration	2

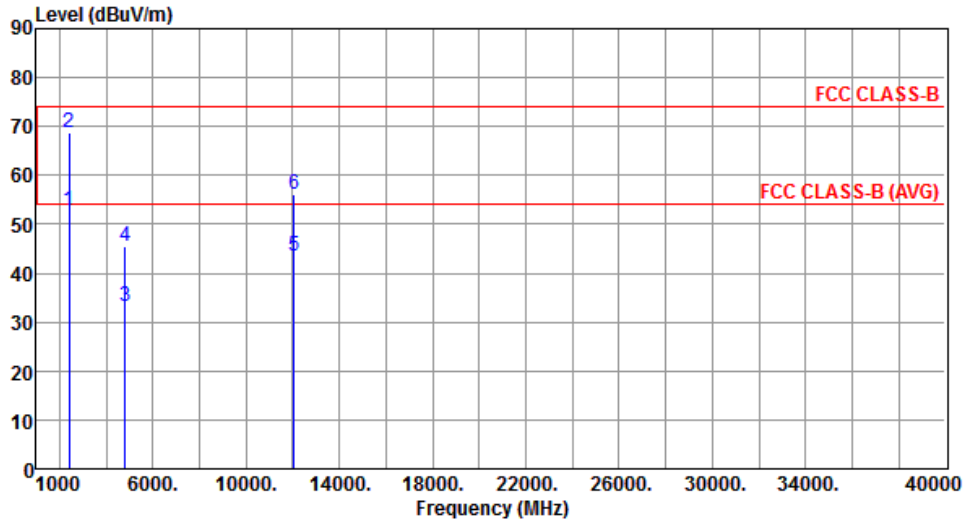

	Freq. MHz	Emission level dBuV/m	Limit dBuV/m	Margin dB	SA reading dBuV	Factor dB	Remark	ANT High cm	Turn Table deg
1	2390.00	52.71	54.00	-1.29	53.67	-0.96	Average	177	271
2	2390.00	68.81	74.00	-5.19	69.77	-0.96	Peak	177	271
3	4824.00	33.12	54.00	-20.88	28.25	4.87	Average	100	80
4	4824.00	45.40	74.00	-28.60	40.53	4.87	Peak	100	80
5	12060.00	43.60	54.00	-10.40	28.68	14.92	Average	100	50
6	12060.00	56.27	74.00	-17.73	41.35	14.92	Peak	100	50

Note 1: Emission Level (dBuV/m) = SA Reading (dBuV/m) + Factor* (dB)

*Factor includes antenna factor , cable loss and amplifier gain

Note 2: Margin (dB) = Emission level (dBuV/m) – Limit (dBuV/m).

Modulation	HT20	Test Freq. (MHz)	2437
Polarization	Horizontal	Test Configuration	2

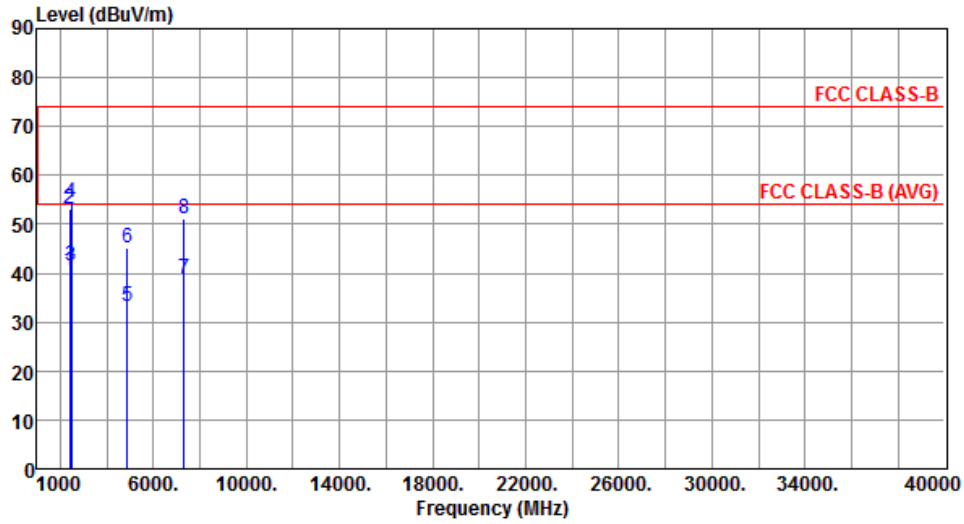

	Freq. MHz	Emission level dBuV/m	Limit dBuV/m	Margin dB	SA reading dBuV	Factor dB	Remark	ANT High cm	Turn Table deg
1	2390.00	40.40	54.00	-13.60	41.36	-0.96	Average	100	232
2	2390.00	53.30	74.00	-20.70	54.26	-0.96	Peak	100	232
3	2483.50	41.44	54.00	-12.56	42.56	-1.12	Average	100	232
4	2483.50	54.57	74.00	-19.43	55.69	-1.12	Peak	100	232
5	4874.00	33.15	54.00	-20.85	28.24	4.91	Average	100	50
6	4874.00	45.28	74.00	-28.72	40.37	4.91	Peak	100	50
7	7311.00	38.92	54.00	-15.08	28.57	10.35	Average	100	90
8	7311.00	51.03	74.00	-22.97	40.68	10.35	Peak	100	90

Note 1: Emission Level (dBuV/m) = SA Reading (dBuV/m) + Factor* (dB)

*Factor includes antenna factor , cable loss and amplifier gain

Note 2: Margin (dB) = Emission level (dBuV/m) – Limit (dBuV/m).

Modulation	HT20	Test Freq. (MHz)	2437
Polarization	Vertical	Test Configuration	2

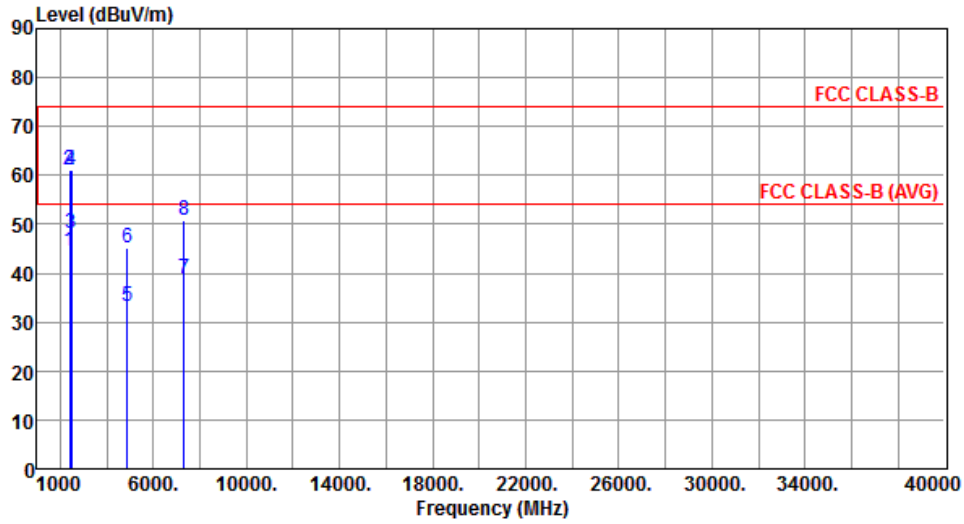

	Freq. MHz	Emission level dBuV/m	Limit dBuV/m	Margin dB	SA reading dBuV	Factor dB	Remark	ANT High cm	Turn Table deg
1	2390.00	44.66	54.00	-9.34	45.62	-0.96	Average	191	273
2	2390.00	61.01	74.00	-12.99	61.97	-0.96	Peak	191	273
3	2483.50	48.20	54.00	-5.80	49.32	-1.12	Average	191	273
4	2483.50	61.20	74.00	-12.80	62.32	-1.12	Peak	191	273
5	4874.00	33.15	54.00	-20.85	28.24	4.91	Average	100	100
6	4874.00	45.30	74.00	-28.70	40.39	4.91	Peak	100	100
7	7311.00	39.00	54.00	-15.00	28.65	10.35	Average	100	20
8	7311.00	50.92	74.00	-23.08	40.57	10.35	Peak	100	20

Note 1: Emission Level (dBuV/m) = SA Reading (dBuV/m) + Factor* (dB)

*Factor includes antenna factor , cable loss and amplifier gain

Note 2: Margin (dB) = Emission level (dBuV/m) – Limit (dBuV/m).

Modulation	HT20	Test Freq. (MHz)	2462
Polarization	Horizontal	Test Configuration	2

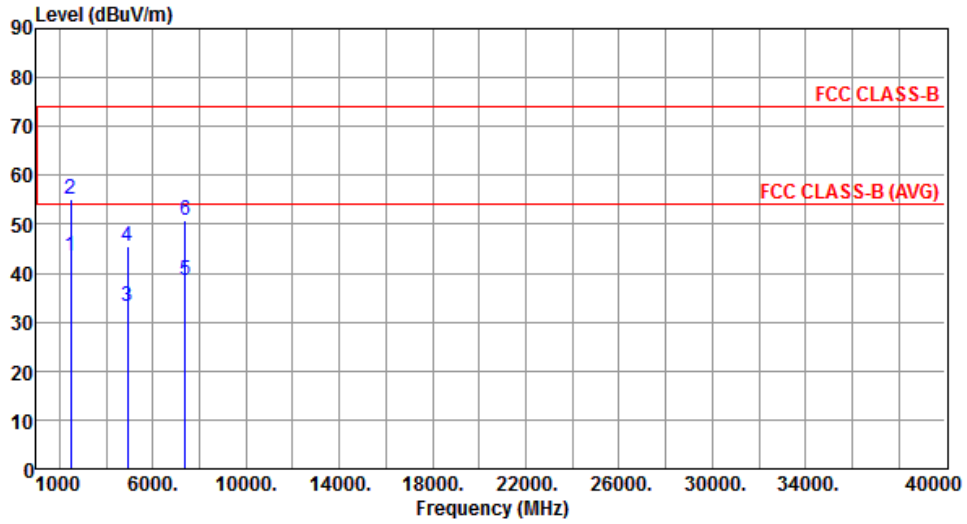

	Freq. MHz	Emission level dBuV/m	Limit dBuV/m	Margin dB	SA reading dBuV	Factor dB	Remark	ANT High cm	Turn Table deg
1	2483.50	43.45	54.00	-10.55	44.57	-1.12	Average	100	229
2	2483.50	55.27	74.00	-18.73	56.39	-1.12	Peak	100	229
3	4924.00	33.28	54.00	-20.72	28.27	5.01	Average	100	60
4	4924.00	45.47	74.00	-28.53	40.46	5.01	Peak	100	60
5	7386.00	38.69	54.00	-15.31	28.54	10.15	Average	100	20
6	7386.00	50.73	74.00	-23.27	40.58	10.15	Peak	100	20

Note 1: Emission Level (dBuV/m) = SA Reading (dBuV/m) + Factor* (dB)

*Factor includes antenna factor , cable loss and amplifier gain

Note 2: Margin (dB) = Emission level (dBuV/m) – Limit (dBuV/m).

Modulation	HT20	Test Freq. (MHz)	2462
Polarization	Vertical	Test Configuration	2

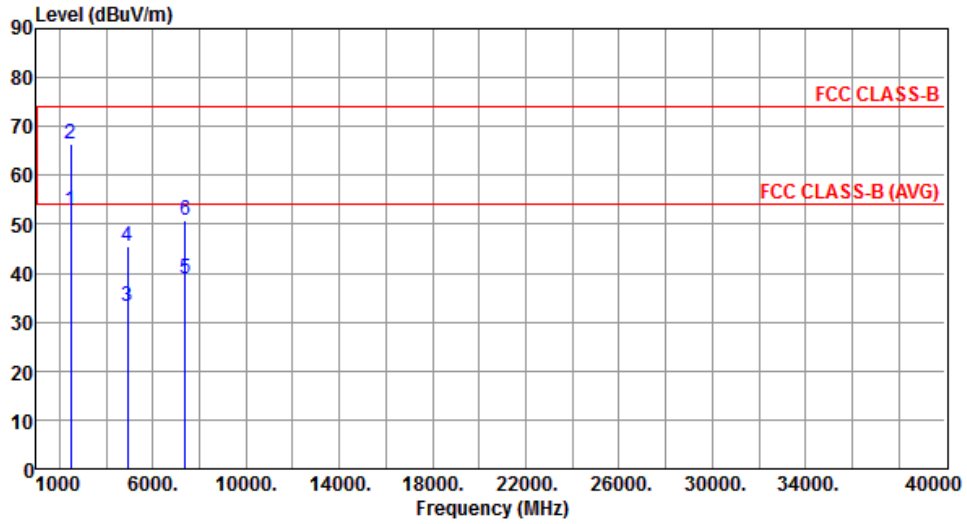

	Freq. MHz	Emission level dBuV/m	Limit dBuV/m	Margin dB	SA reading dBuV	Factor dB	Remark	ANT High cm	Turn Table deg
1	2483.50	52.65	54.00	-1.35	53.77	-1.12	Average	177	271
2	2483.50	66.55	74.00	-7.45	67.67	-1.12	Peak	177	271
3	4924.00	33.25	54.00	-20.75	28.24	5.01	Average	100	70
4	4924.00	45.54	74.00	-28.46	40.53	5.01	Peak	100	70
5	7386.00	38.81	54.00	-15.19	28.66	10.15	Average	100	40
6	7386.00	50.79	74.00	-23.21	40.64	10.15	Peak	100	40

Note 1: Emission Level (dBuV/m) = SA Reading (dBuV/m) + Factor* (dB)

*Factor includes antenna factor , cable loss and amplifier gain

Note 2: Margin (dB) = Emission level (dBuV/m) – Limit (dBuV/m).

3.5.11 Transmitter Radiated Unwanted Emissions (Above 1GHz) for HT40

Modulation	HT40	Test Freq. (MHz)	2422
Polarization	Horizontal	Test Configuration	2

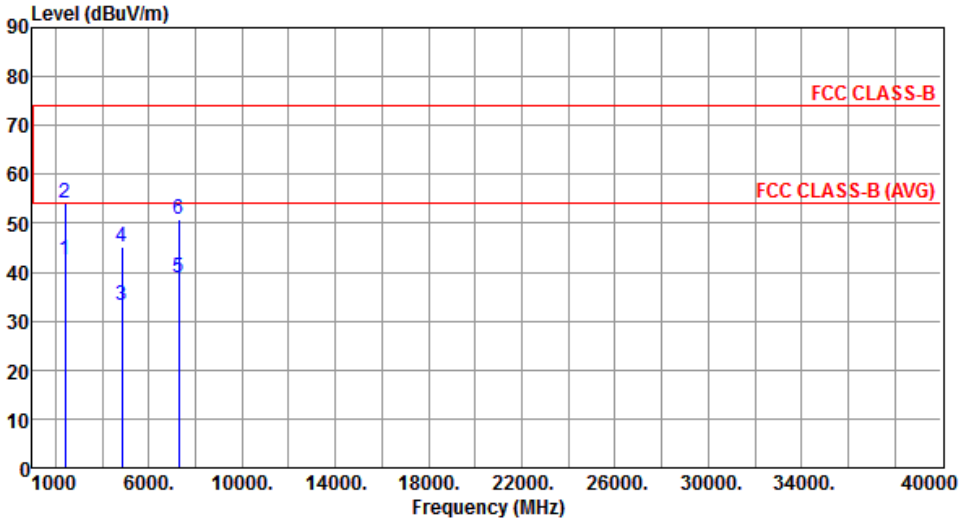

The graph plots Level (dBuV/m) on the y-axis (0 to 90) against Frequency (MHz) on the x-axis (1000 to 40000). Two horizontal red lines represent the FCC CLASS-B limit at approximately 74 dBuV/m and the FCC CLASS-B (AVG) limit at approximately 54 dBuV/m. Six vertical blue lines indicate measured emission levels at various frequencies, labeled 1 through 6. Peak 2 is the highest, exceeding the FCC CLASS-B limit.

	Freq. MHz	Emission level dBuV/m	Limit dBuV/m	Margin dB	SA reading dBuV	Factor dB	Remark	ANT High cm	Turn Table deg
1	2390.00	42.56	54.00	-11.44	43.52	-0.96	Average	100	231
2	2390.00	54.25	74.00	-19.75	55.21	-0.96	Peak	100	231
3	4844.00	33.07	54.00	-20.93	28.14	4.93	Average	100	25
4	4844.00	45.18	74.00	-28.82	40.25	4.93	Peak	100	25
5	7266.00	38.95	54.00	-15.05	28.55	10.40	Average	100	45
6	7266.00	50.86	74.00	-23.14	40.46	10.40	Peak	100	45

Note 1: Emission Level (dBuV/m) = SA Reading (dBuV/m) + Factor* (dB)
 *Factor includes antenna factor , cable loss and amplifier gain
 Note 2: Margin (dB) = Emission level (dBuV/m) – Limit (dBuV/m).

Modulation	HT40	Test Freq. (MHz)	2422
Polarization	Vertical	Test Configuration	2

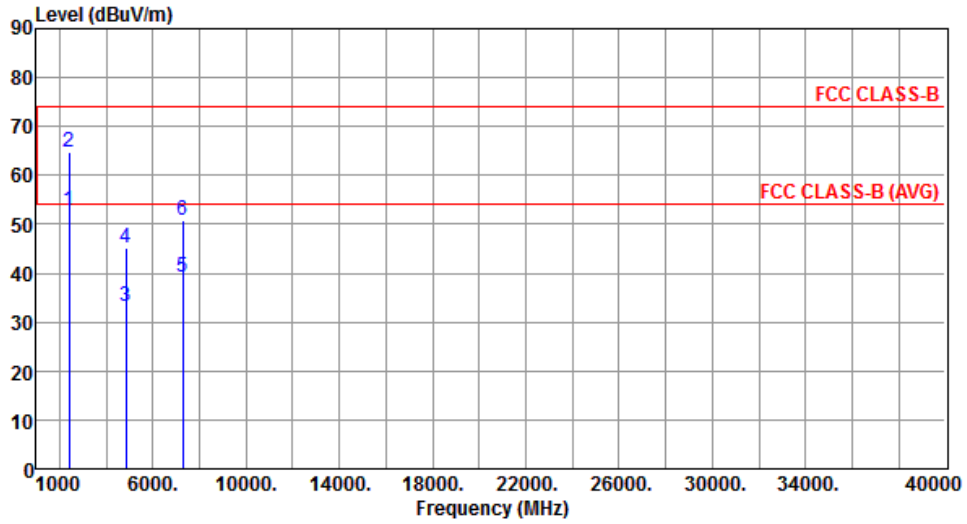

	Freq. MHz	Emission level dBuV/m	Limit dBuV/m	Margin dB	SA reading dBuV	Factor dB	Remark	ANT High cm	Turn Table deg
1	2390.00	52.69	54.00	-1.31	53.65	-0.96	Average	195	271
2	2390.00	64.76	74.00	-9.24	65.72	-0.96	Peak	195	271
3	4844.00	33.13	54.00	-20.87	28.20	4.93	Average	100	30
4	4844.00	45.24	74.00	-28.76	40.31	4.93	Peak	100	30
5	7266.00	39.09	54.00	-14.91	28.69	10.40	Average	100	50
6	7266.00	50.97	74.00	-23.03	40.57	10.40	Peak	100	50

Note 1: Emission Level (dBuV/m) = SA Reading (dBuV/m) + Factor* (dB)

*Factor includes antenna factor , cable loss and amplifier gain

Note 2: Margin (dB) = Emission level (dBuV/m) – Limit (dBuV/m).

Modulation	HT40	Test Freq. (MHz)	2437
Polarization	Horizontal	Test Configuration	2

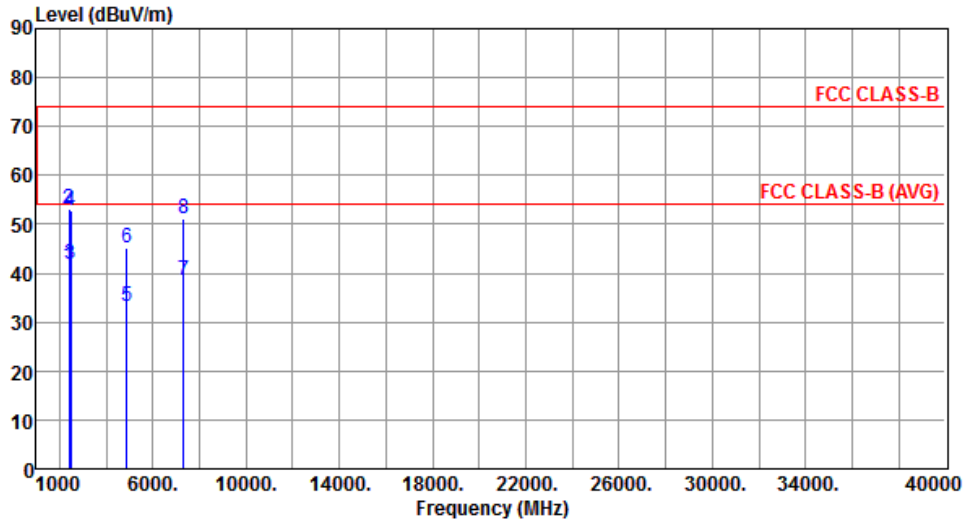

	Freq. MHz	Emission level dBuV/m	Limit dBuV/m	Margin dB	SA reading dBuV	Factor dB	Remark	ANT High cm	Turn Table deg
1	2390.00	41.44	54.00	-12.56	42.40	-0.96	Average	100	230
2	2390.00	52.99	74.00	-21.01	53.95	-0.96	Peak	100	230
3	2483.50	41.70	54.00	-12.30	42.82	-1.12	Average	100	230
4	2483.50	52.92	74.00	-21.08	54.04	-1.12	Peak	100	230
5	4874.00	33.12	54.00	-20.88	28.21	4.91	Average	100	60
6	4874.00	45.15	74.00	-28.85	40.24	4.91	Peak	100	60
7	7311.00	38.67	54.00	-15.33	28.32	10.35	Average	100	90
8	7311.00	51.21	74.00	-22.79	40.86	10.35	Peak	100	90

Note 1: Emission Level (dBuV/m) = SA Reading (dBuV/m) + Factor* (dB)

*Factor includes antenna factor , cable loss and amplifier gain

Note 2: Margin (dB) = Emission level (dBuV/m) – Limit (dBuV/m).

Modulation	HT40	Test Freq. (MHz)	2437
Polarization	Vertical	Test Configuration	2

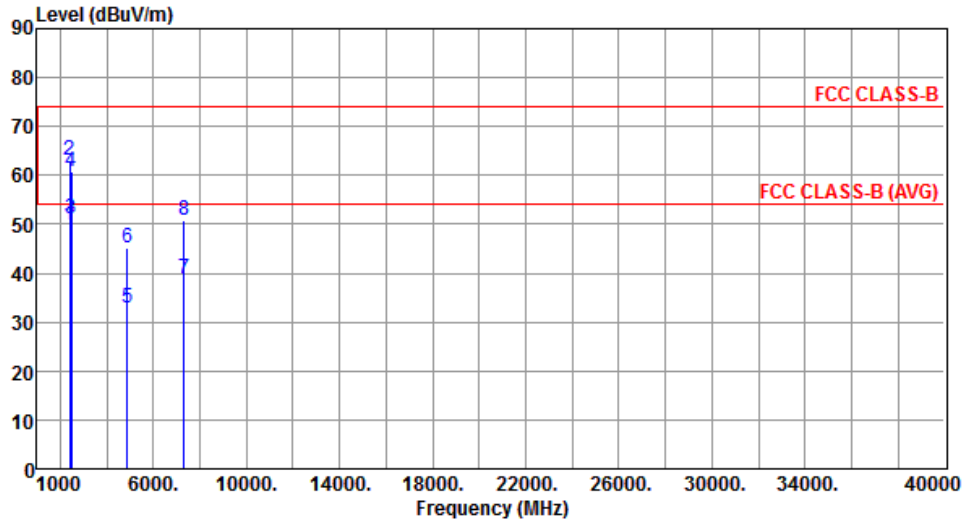

	Freq. MHz	Emission level dBuV/m	Limit dBuV/m	Margin dB	SA reading dBuV	Factor dB	Remark	ANT High cm	Turn Table deg
1	2390.00	49.84	54.00	-4.16	50.80	-0.96	Average	146	261
2	2390.00	62.94	74.00	-11.06	63.90	-0.96	Peak	146	261
3	2483.50	51.22	54.00	-2.78	52.34	-1.12	Average	165	261
4	2483.50	60.66	74.00	-13.34	61.78	-1.12	Peak	165	261
5	4874.00	33.03	54.00	-20.97	28.12	4.91	Average	100	30
6	4874.00	45.27	74.00	-28.73	40.36	4.91	Peak	100	30
7	7311.00	38.80	54.00	-15.20	28.45	10.35	Average	100	50
8	7311.00	50.93	74.00	-23.07	40.58	10.35	Peak	100	50

Note 1: Emission Level (dBuV/m) = SA Reading (dBuV/m) + Factor* (dB)

*Factor includes antenna factor , cable loss and amplifier gain

Note 2: Margin (dB) = Emission level (dBuV/m) – Limit (dBuV/m).

Modulation	HT40	Test Freq. (MHz)	2452
Polarization	Horizontal	Test Configuration	2

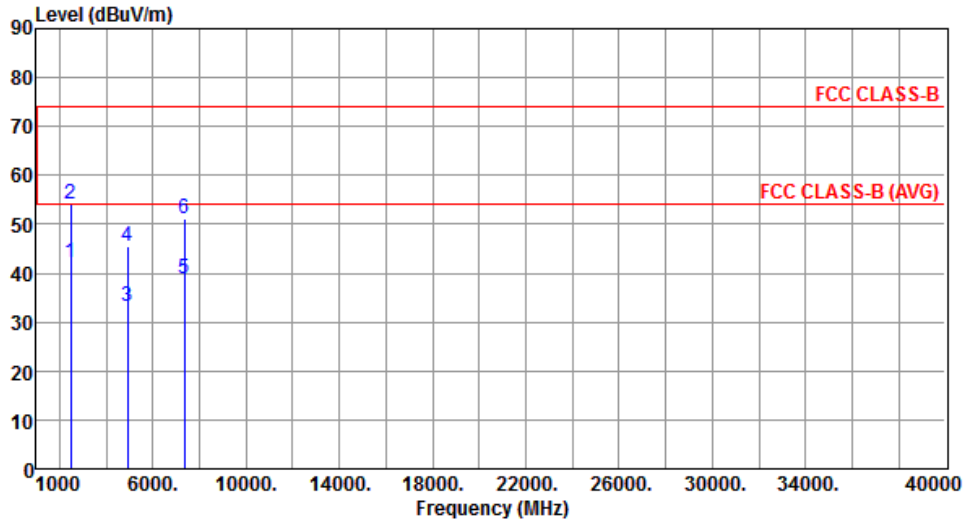

	Freq. MHz	Emission level dBuV/m	Limit dBuV/m	Margin dB	SA reading dBuV	Factor dB	Remark	ANT High cm	Turn Table deg
1	2483.50	42.12	54.00	-11.88	43.24	-1.12	Average	100	229
2	2483.50	54.17	74.00	-19.83	55.29	-1.12	Peak	100	229
3	4904.00	33.12	54.00	-20.88	28.21	4.91	Average	100	30
4	4904.00	45.60	74.00	-28.40	40.69	4.91	Peak	100	30
5	7356.00	38.80	54.00	-15.20	28.57	10.23	Average	100	60
6	7356.00	51.10	74.00	-22.90	40.87	10.23	Peak	100	60

Note 1: Emission Level (dBuV/m) = SA Reading (dBuV/m) + Factor* (dB)

*Factor includes antenna factor , cable loss and amplifier gain

Note 2: Margin (dB) = Emission level (dBuV/m) – Limit (dBuV/m).

Modulation	HT40	Test Freq. (MHz)	2452
Polarization	Vertical	Test Configuration	2

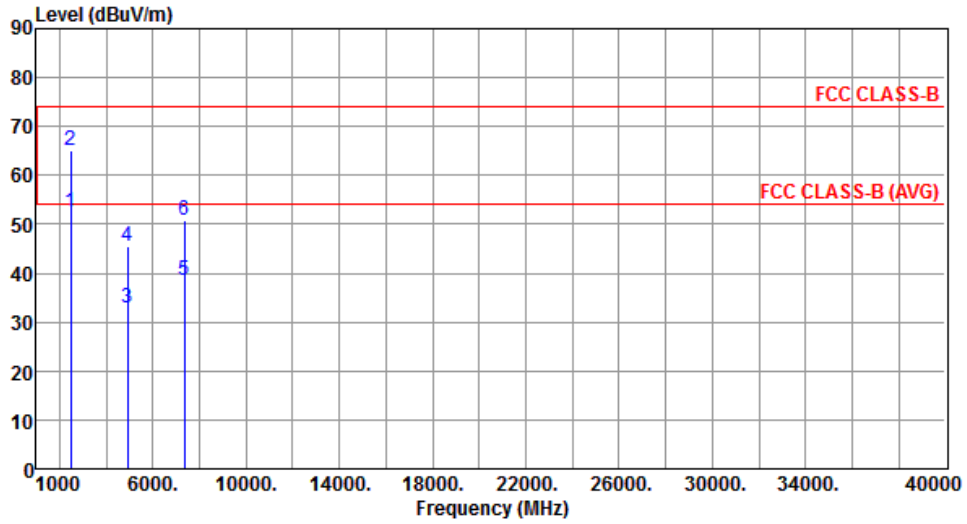

	Freq. MHz	Emission level dBuV/m	Limit dBuV/m	Margin dB	SA reading dBuV	Factor dB	Remark	ANT High cm	Turn Table deg
1	2483.50	52.61	54.00	-1.39	53.73	-1.12	Average	192	269
2	2483.50	64.99	74.00	-9.01	66.11	-1.12	Peak	192	269
3	4904.00	33.03	54.00	-20.97	28.12	4.91	Average	100	20
4	4904.00	45.45	74.00	-28.55	40.54	4.91	Peak	100	20
5	7356.00	38.68	54.00	-15.32	28.45	10.23	Average	100	30
6	7356.00	50.85	74.00	-23.15	40.62	10.23	Peak	100	30

Note 1: Emission Level (dBuV/m) = SA Reading (dBuV/m) + Factor* (dB)

*Factor includes antenna factor , cable loss and amplifier gain

Note 2: Margin (dB) = Emission level (dBuV/m) – Limit (dBuV/m).

3.6 Emissions in Non-Restricted Frequency Bands

3.6.1 Emissions in Non-Restricted Frequency Bands Limit

Peak power in any 100 kHz bandwidth outside of the authorized frequency band shall be attenuated by at least 30 dB relative to the maximum in-band peak PSD level in 100 kHz.

3.6.2 Test Procedures

Reference level measurement

1. Set RBW=100kHz, VBW = 300kHz , Detector = Peak, Sweep time = Auto
2. Trace = max hold , Allow Trace to fully stabilize
3. Use the peak marker function to determine the maximum PSD level

Emission level measurement

1. Set RBW=100kHz, VBW = 300kHz , Detector = Peak, Sweep time = Auto
2. Trace = max hold , Allow Trace to fully stabilize
3. Scan Frequency range is up to 25GHz
4. Use the peak marker function to determine the maximum amplitude level

3.6.3 Test Setup

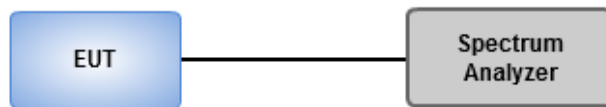

Non-beamforming mode

3.6.4 Unwanted Emissions into Non-Restricted Frequency Bands

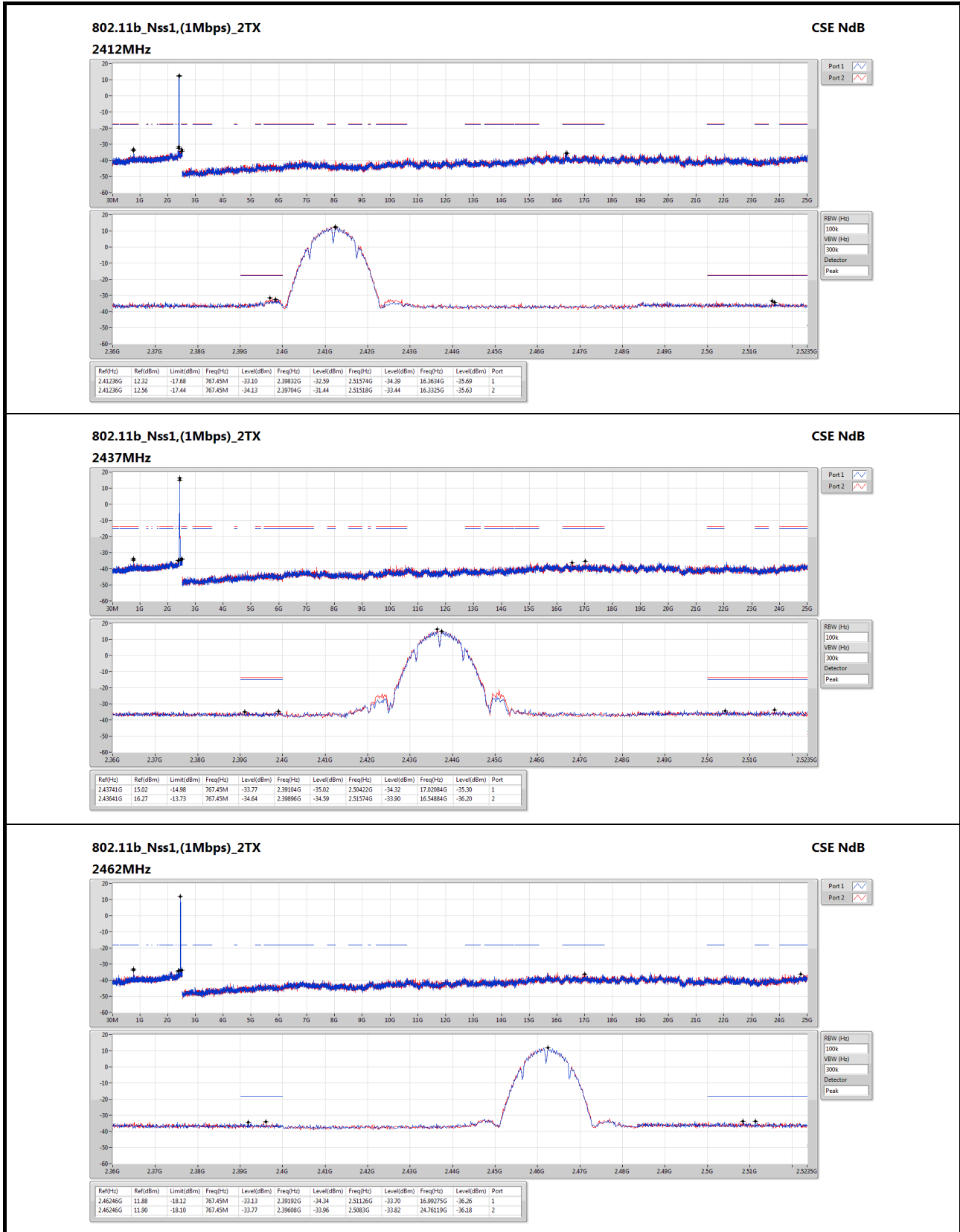
802.11b_Nss1,(1Mbps)_2TX
CSE NdB
2462MHz

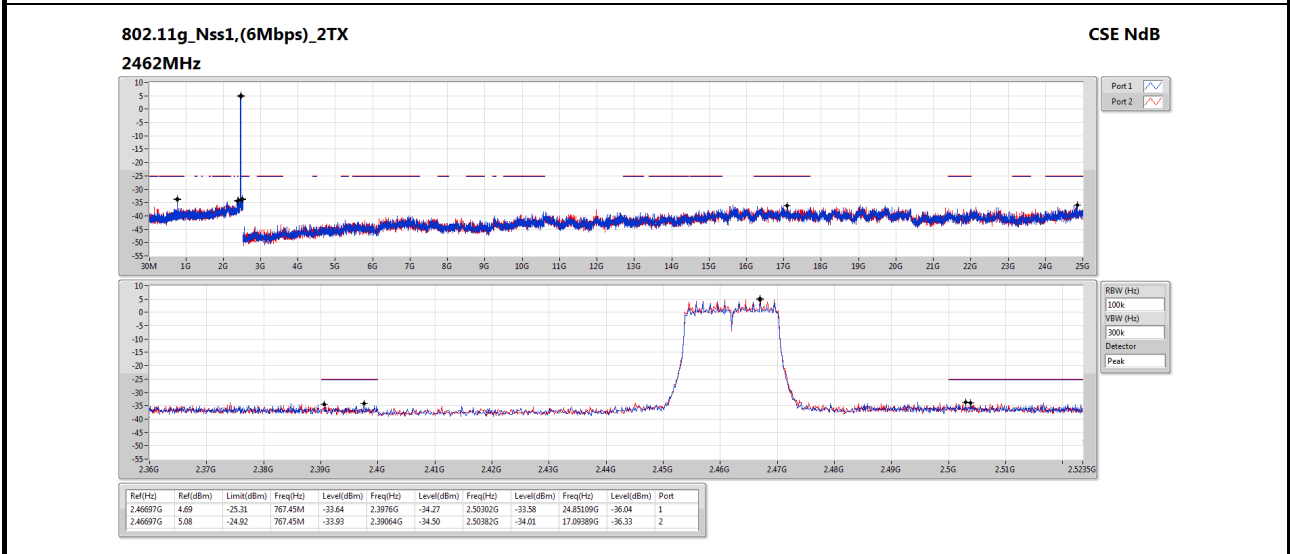
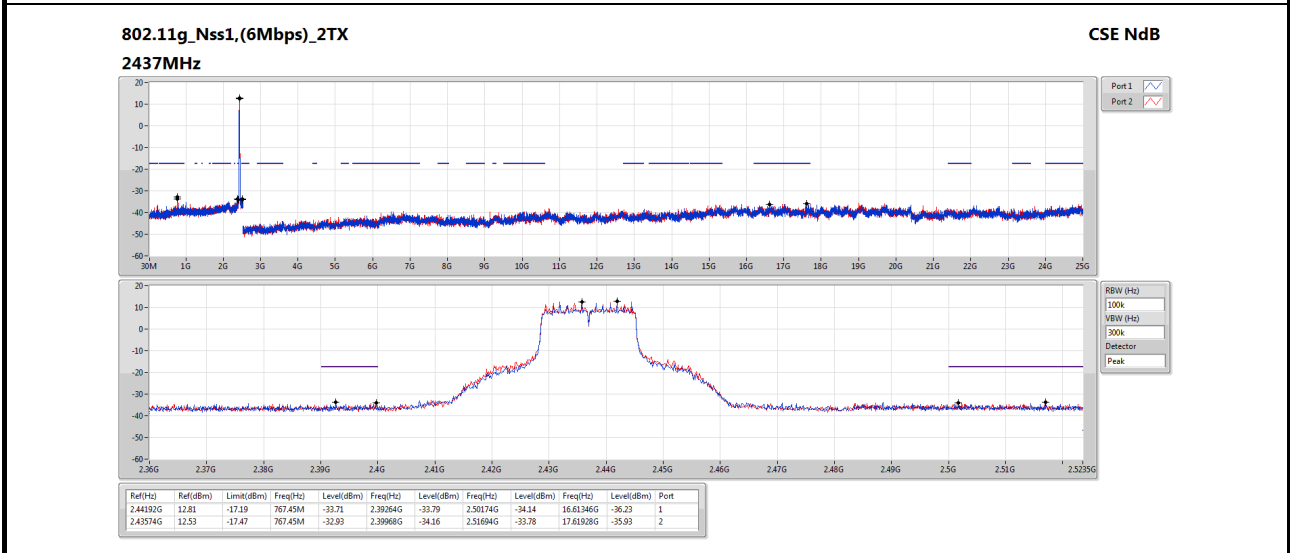
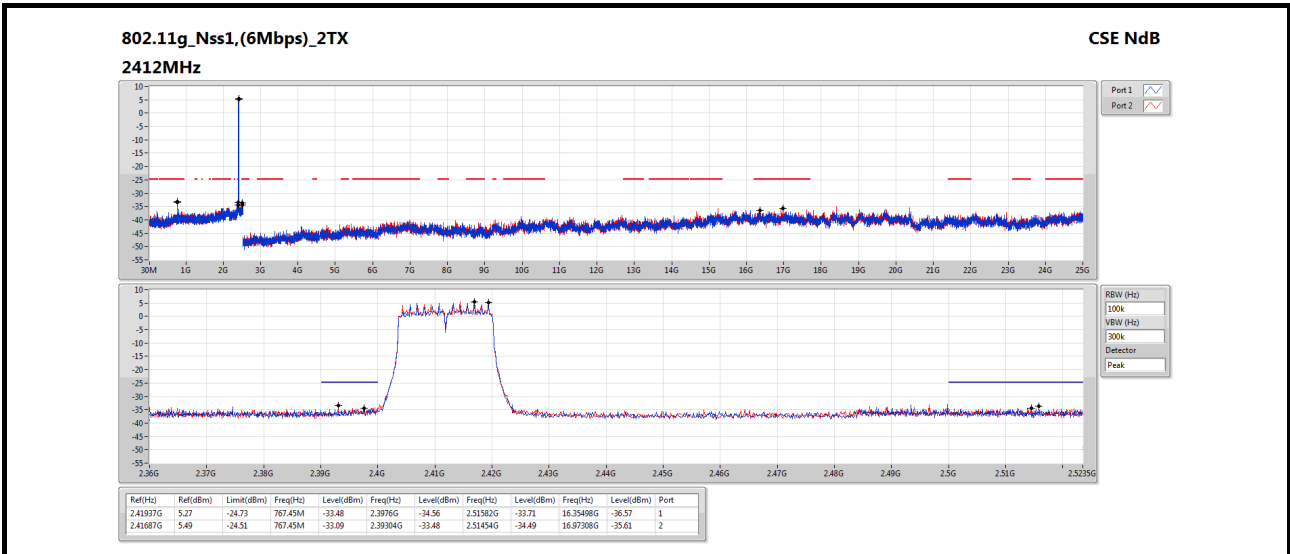

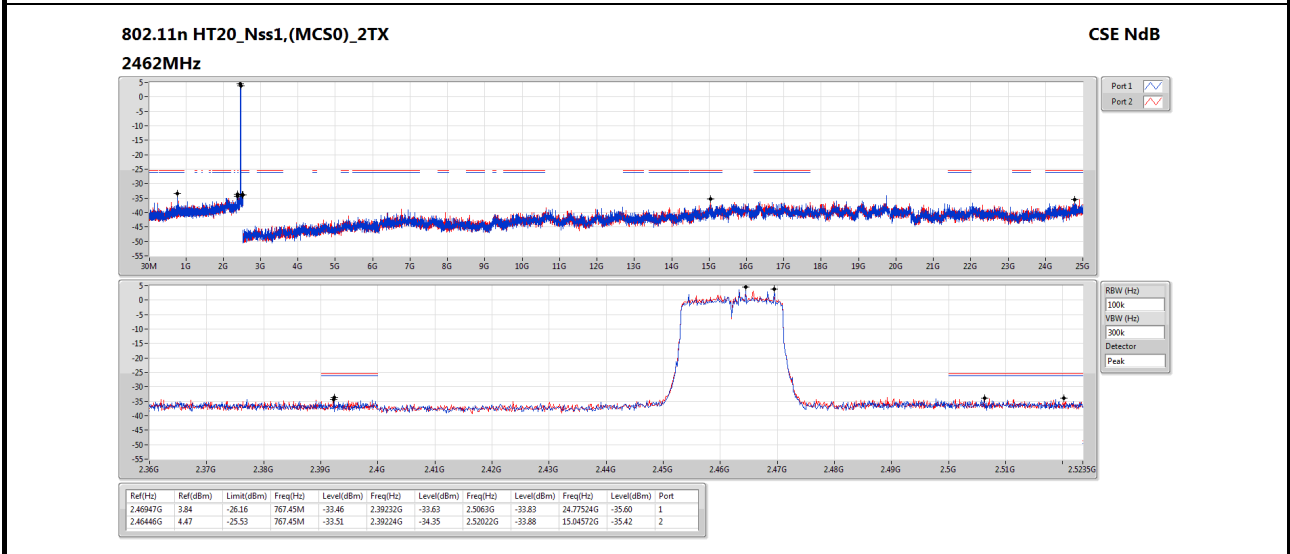
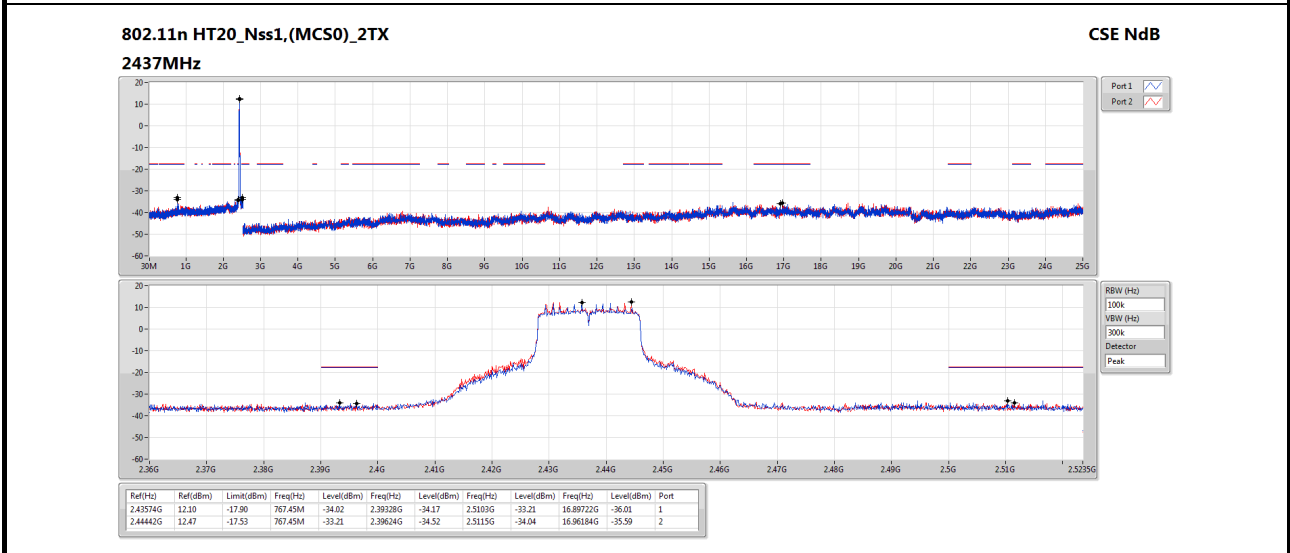
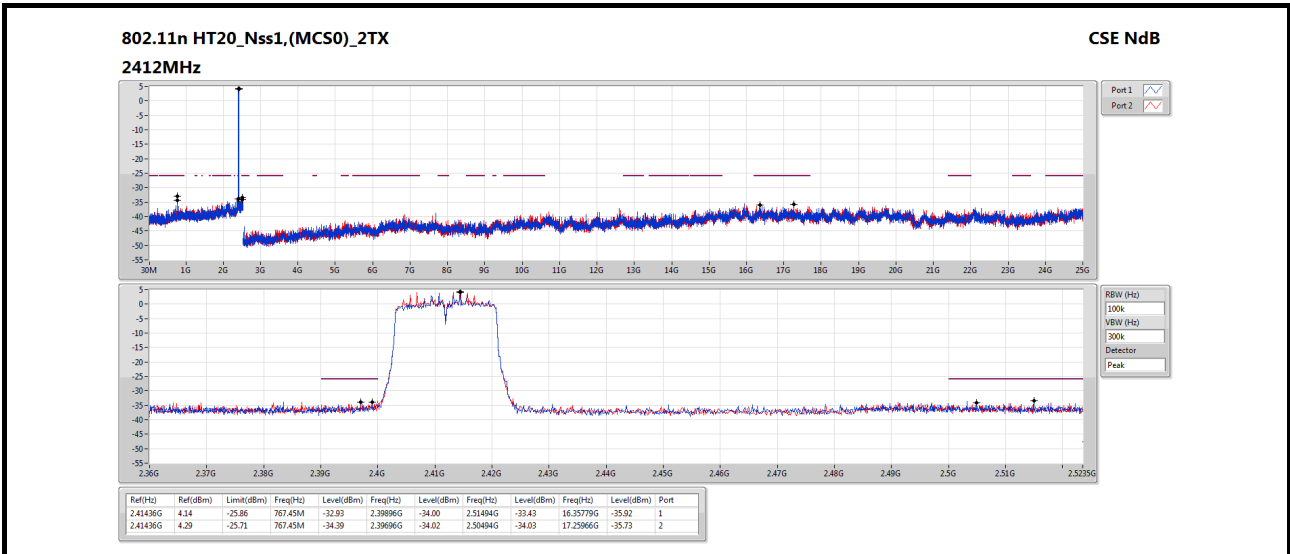

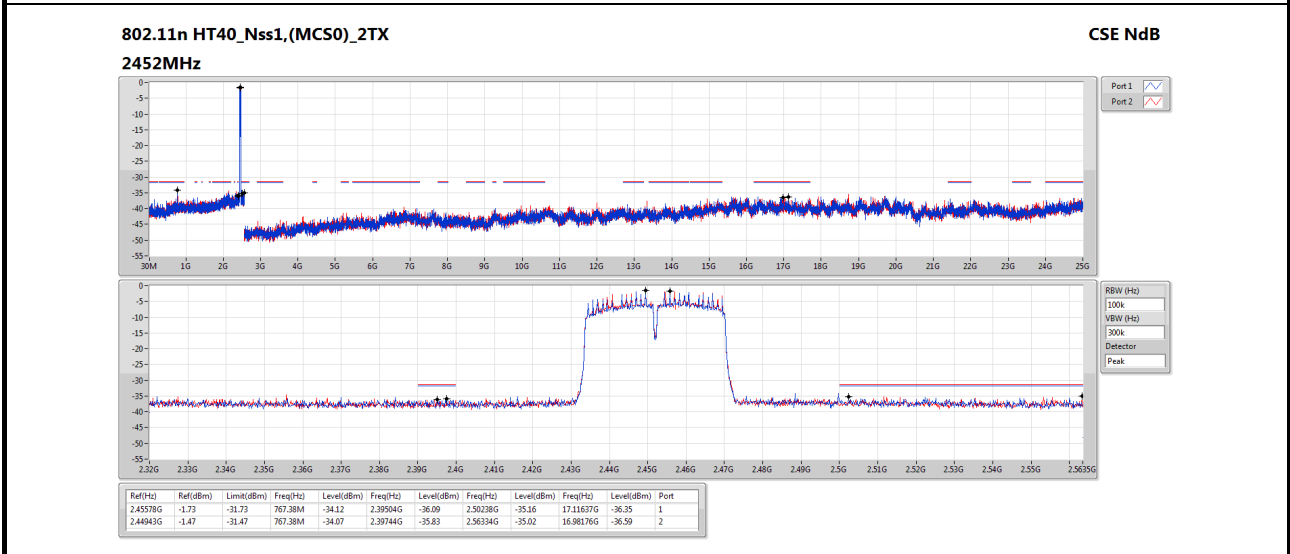
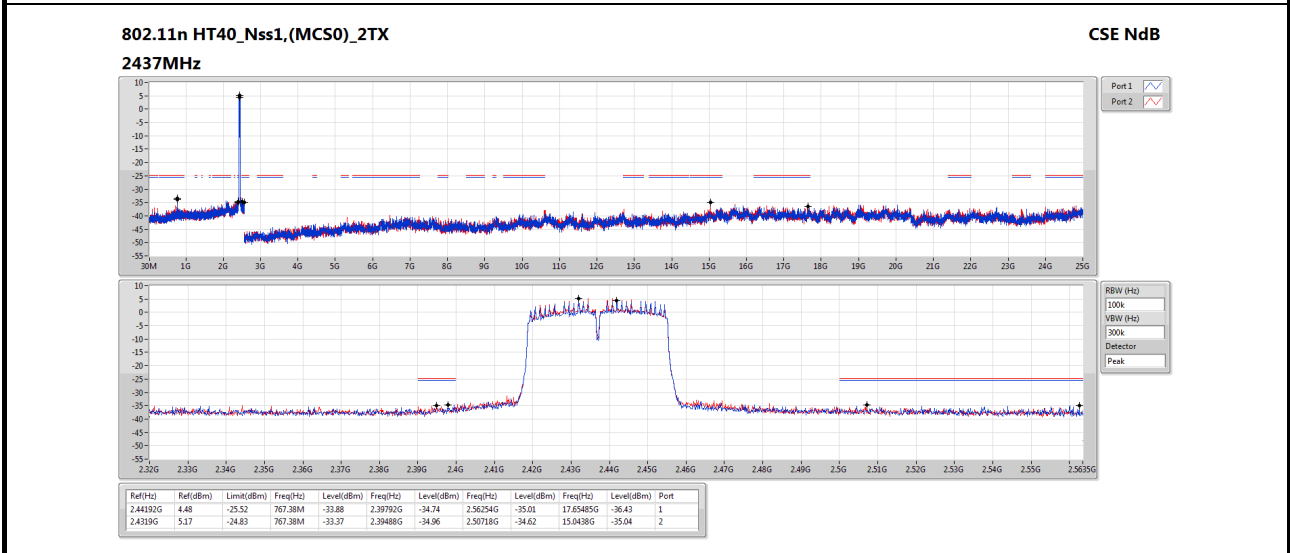
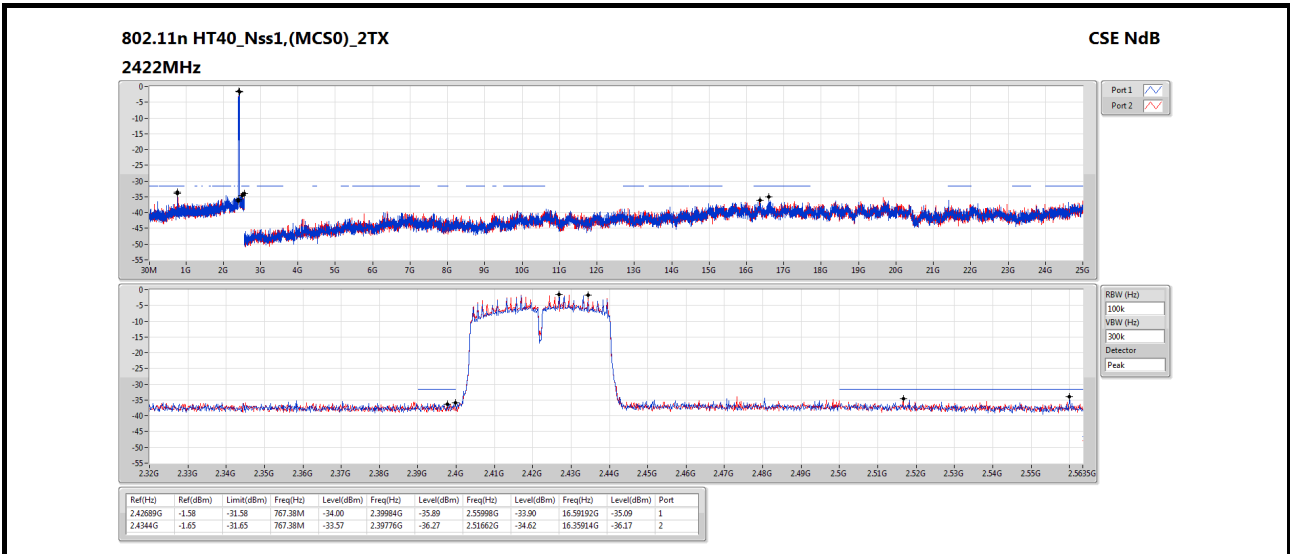

Beamforming mode

3.6.5 Unwanted Emissions into Non-Restricted Frequency Bands

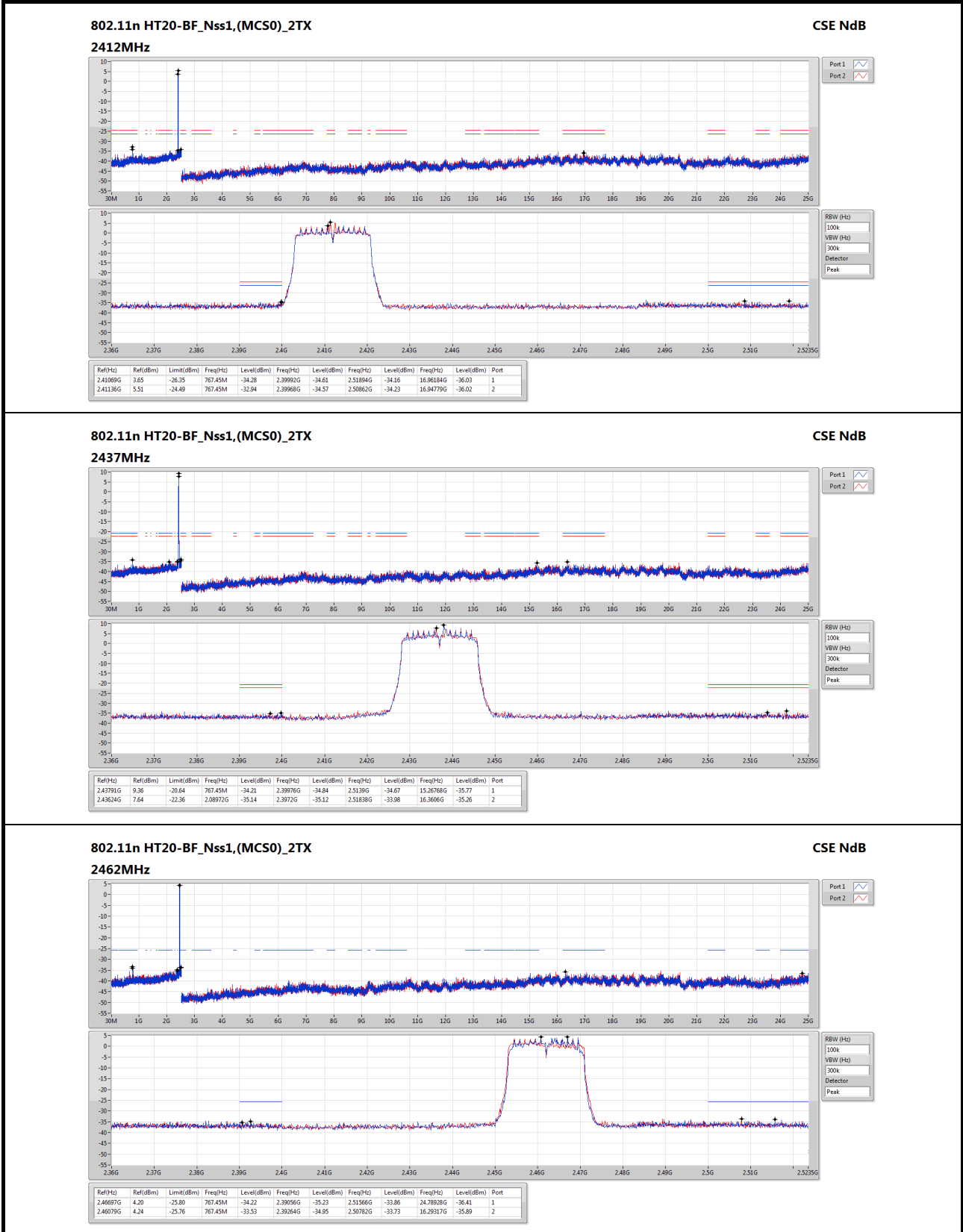

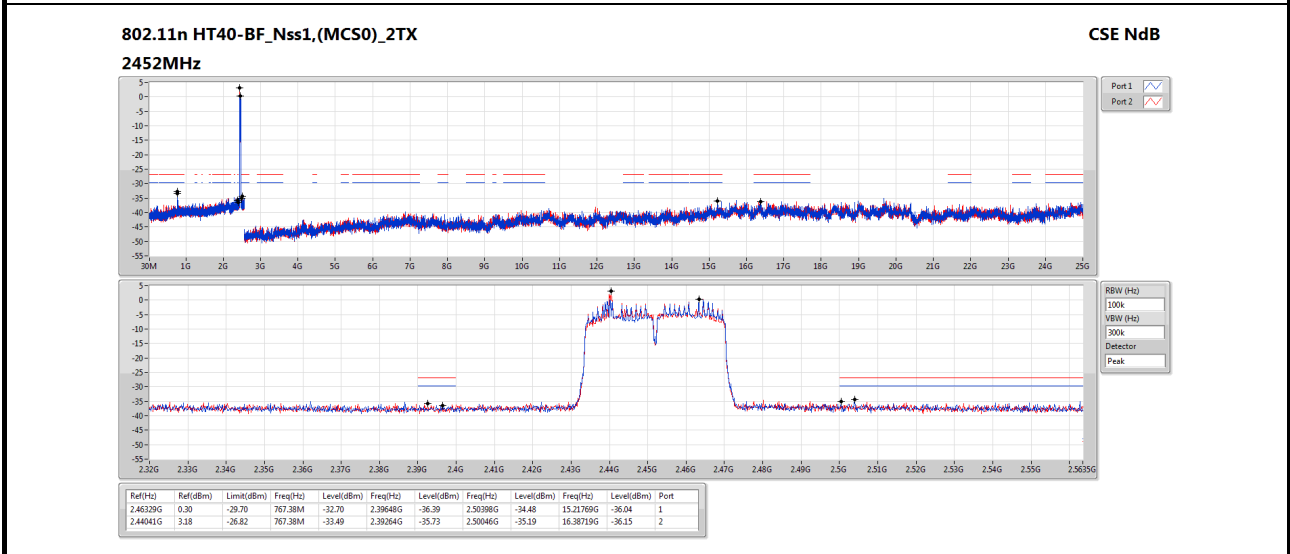
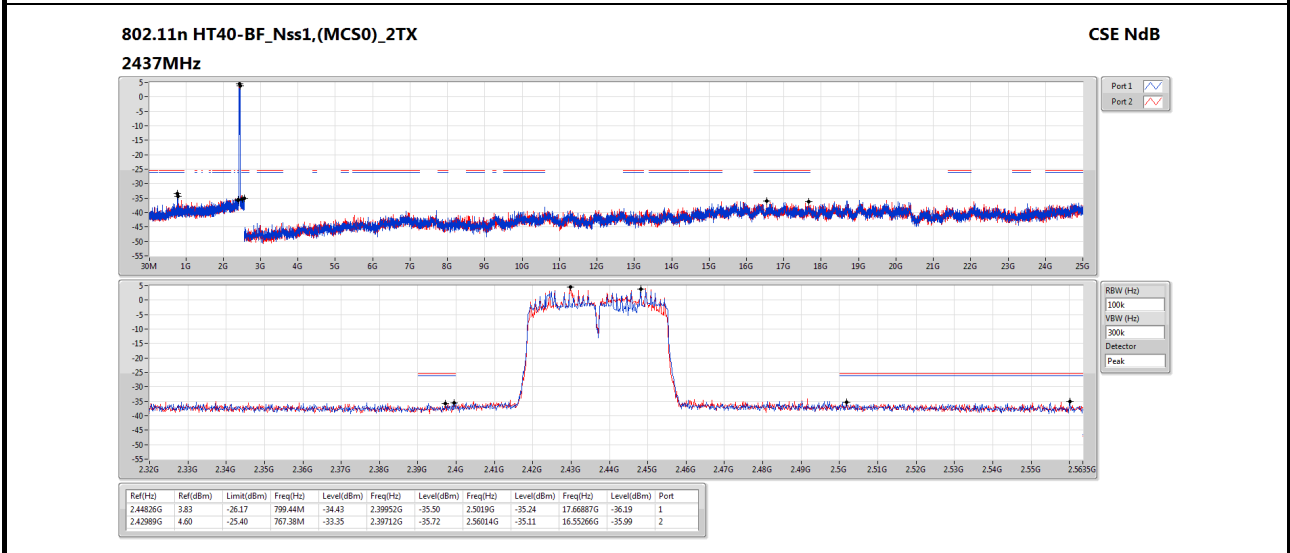
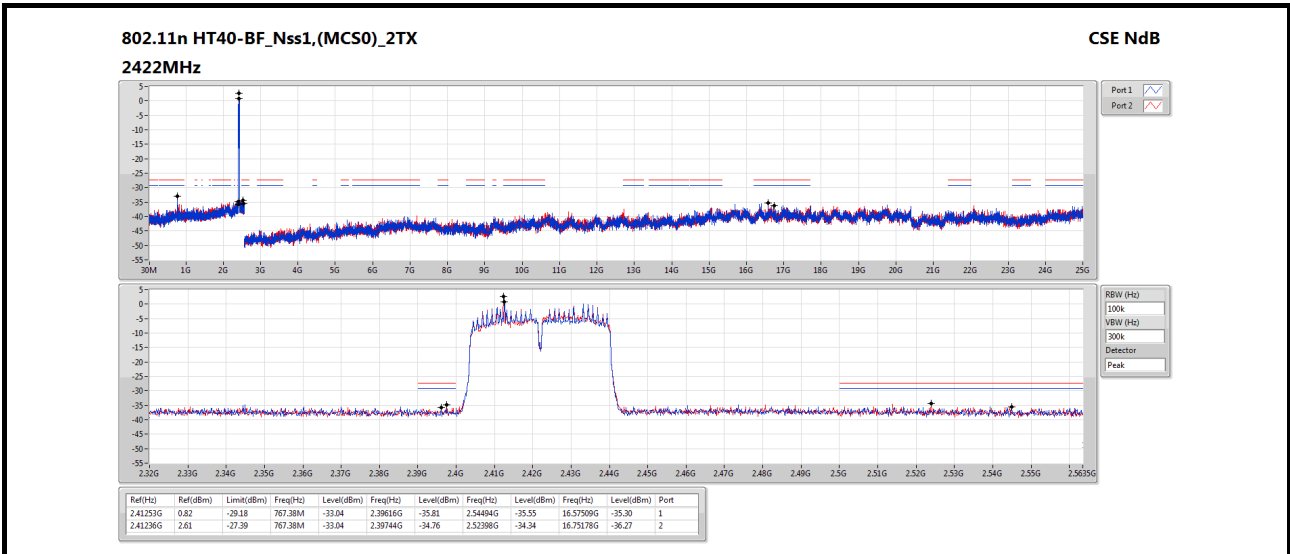

4 Test laboratory information

Established in 2012, ICC provides foremost EMC & RF Testing and advisory consultation services by our skilled engineers and technicians. Our services employ a wide variety of advanced edge test equipment and one of the widest certification extents in the business.

International Certification Corp (EMC and Wireless Communication Laboratory), it is our definitive objective is to institute long term, trust-based associations with our clients. The expectation we set up with our clients is based on outstanding service, practical expertise and devotion to a certified value structure. Our passion is to grant our clients with best EMC / RF services by oriented knowledgeable and accommodating staff.

Our Test sites are located at Linkou District and Kwei Shan District. Location map can be found on our website <http://www.icertifi.com.tw>.

Linkou

Tel: 886-2-2601-1640

No. 30-2, Ding Fwu Tsuen, Lin
Kou District, New Taipei City,
Taiwan, R.O.C.

Kwei Shan

Tel: 886-3-271-8666

No. 3-1, Lane 6, Wen San 3rd St.,
Kwei Shan District, Tao Yuan City
333, Taiwan, R.O.C.

Kwei Shan Site II

Tel: 886-3-271-8640

No. 14-1, Lane 19, Wen San 3rd
St., Kwei Shan District, Tao Yuan
City 333, Taiwan, R.O.C.

If you have any suggestion, please feel free to contact us as below information.

Tel: 886-3-271-8666

Fax: 886-3-318-0155

Email: ICC_Service@icertifi.com.tw

==END==