



A D T

# FCC TEST REPORT (15.247)

**REPORT NO.:** RF130726C17

**MODEL NO.:** BW1253s

**FCC ID:** 2AAS9-1253XW

**RECEIVED:** Jul. 26, 2013

**TESTED:** Aug. 02 ~ Sep. 17, 2013

**ISSUED:** Sep. 25, 2013

**APPLICANT:** BROWAN COMMUNICATIONS Co., Ltd.

**ADDRESS:** No. 15-1, Zhonghua Rd., Hsinchu Industrial Park,  
Hukou, Hsinchu, Taiwan, R. O. C. 303

**ISSUED BY:** Bureau Veritas Consumer Products Services  
(H.K.) Ltd., Taoyuan Branch

**LAB ADDRESS:** No. 47, 14th Ling, Chia Pau Vil., Lin Kou Dist.,  
New Taipei City, Taiwan, R.O.C.

**TEST LOCATION:** No. 19, Hwa Ya 2nd Rd, Wen Hwa Tsuen, Kwei  
Shan Hsiang, Taoyuan Hsien 333, Taiwan, R.O.C.

This report should not be used by the client to claim product certification, approval, or endorsement by TAF or any government agencies.



This report is for your exclusive use. Any copying or replication of this report to or for any other person or entity, or use of our name or trademark, is permitted only with our prior written permission. This report sets forth our findings solely with respect to the test samples identified herein. The results set forth in this report are not indicative or representative of the quality or characteristics of the lot from which a test sample was taken or any similar or identical product unless specifically and expressly noted. Our report includes all of the tests requested by you and the results thereof based upon the information that you provided to us. You have 60 days from date of issuance of this report to notify us of any material error or omission caused by our negligence, provided, however, that such notice shall be in writing and shall specifically address the issue you wish to raise. A failure to raise such issue within the prescribed time shall constitute your unqualified acceptance of the completeness of this report, the tests conducted and the correctness of the report contents. Unless specific mention, the uncertainty of measurement has been explicitly taken into account to declare the compliance or non-compliance to the specification.



A D T

## TABLE OF CONTENTS

RELEASE CONTROL RECORD.....	5
1. CERTIFICATION.....	6
2. SUMMARY OF TEST RESULTS .....	7
2.1 MEASUREMENT UNCERTAINTY.....	7
3. GENERAL INFORMATION.....	8
3.1 GENERAL DESCRIPTION OF EUT .....	8
3.2 DESCRIPTION OF TEST MODES .....	10
3.2.1 TEST MODE APPLICABILITY AND TESTED CHANNEL DETAIL .....	11
3.3 DUTY CYCLE OF TEST SIGNAL.....	15
3.4 DESCRIPTION OF SUPPORT UNITS .....	17
3.4.1 CONFIGURATION OF SYSTEM UNDER TEST .....	18
3.5 GENERAL DESCRIPTION OF APPLIED STANDARDS .....	20
4. TEST TYPES AND RESULTS (FOR 2.4GHZ BAND).....	21
4.1 RADIATED EMISSION AND BANDEDGE MEASUREMENT .....	21
4.1.1 LIMITS OF RADIATED EMISSION AND BANDEDGE MEASUREMENT .....	21
4.1.2 TEST INSTRUMENTS.....	22
4.1.3 TEST PROCEDURES .....	23
4.1.4 DEVIATION FROM TEST STANDARD.....	23
4.1.5 TEST SETUP.....	24
4.1.6 EUT OPERATING CONDITIONS .....	25
4.1.7 TEST RESULTS .....	26
4.2 CONDUCTED EMISSION MEASUREMENT .....	40
4.2.1 LIMITS OF CONDUCTED EMISSION MEASUREMENT .....	40
4.2.2 TEST INSTRUMENTS.....	40
4.2.3 TEST PROCEDURES .....	41
4.2.4 DEVIATION FROM TEST STANDARD.....	41
4.2.5 TEST SETUP.....	41
4.2.6 EUT OPERATING CONDITIONS .....	41
4.2.7 TEST RESULTS .....	42
4.3 6dB BANDWIDTH MEASUREMENT .....	46
4.3.1 LIMITS OF 6dB BANDWIDTH MEASUREMENT .....	46
4.3.2 TEST SETUP.....	46
4.3.3 TEST INSTRUMENTS.....	46
4.3.4 TEST PROCEDURE.....	46
4.3.5 DEVIATION FROM TEST STANDARD.....	46
4.3.6 EUT OPERATING CONDITIONS .....	46
4.3.7 TEST RESULTS .....	47



A D T

4.4	CONDUCTED OUTPUT POWER.....	49
4.4.1	LIMITS OF CONDUCTED OUTPUT POWER MEASUREMENT .....	49
4.4.2	TEST SETUP .....	49
4.4.3	TEST INSTRUMENTS.....	49
4.4.4	TEST PROCEDURES .....	49
4.4.5	DEVIATION FROM TEST STANDARD.....	50
4.4.6	EUT OPERATING CONDITIONS .....	50
4.4.7	TEST RESULTS .....	51
4.5	POWER SPECTRAL DENSITY MEASUREMENT .....	53
4.5.1	LIMITS OF POWER SPECTRAL DENSITY MEASUREMENT .....	53
4.5.2	TEST SETUP.....	53
4.5.3	TEST INSTRUMENTS.....	53
4.5.4	TEST PROCEDURE.....	53
4.5.5	DEVIATION FROM TEST STANDARD.....	53
4.5.6	EUT OPERATING CONDITION.....	53
4.5.7	TEST RESULTS .....	54
4.6	CONDUCTED OUT OF BAND EMISSION MEASUREMENT.....	56
4.6.1	LIMITS OF CONDUCTED OUT OF BAND EMISSION MEASUREMENT .....	56
4.6.2	TEST SETUP.....	56
4.6.3	TEST INSTRUMENTS.....	56
4.6.4	TEST PROCEDURE.....	56
4.6.5	DEVIATION FROM TEST STANDARD.....	57
4.6.6	EUT OPERATING CONDITION.....	57
4.6.7	TEST RESULTS .....	57
5.	TEST TYPES AND RESULTS (FOR 5.0GHZ BAND).....	66
5.1	RADIATED EMISSION MEASUREMENT .....	66
5.1.1	LIMITS OF RADIATED EMISSION MEASUREMENT .....	66
5.1.2	TEST INSTRUMENTS.....	67
5.1.3	TEST PROCEDURES .....	67
5.1.4	DEVIATION FROM TEST STANDARD.....	67
5.1.5	TEST SETUP.....	67
5.1.6	EUT OPERATING CONDITIONS .....	67
5.1.7	TEST RESULTS .....	68
5.2	CONDUCTED EMISSION MEASUREMENT .....	78
5.2.1	LIMITS OF CONDUCTED EMISSION MEASUREMENT .....	78
5.2.2	TEST INSTRUMENTS.....	78
5.2.3	TEST PROCEDURES .....	78
5.2.4	DEVIATION FROM TEST STANDARD.....	78
5.2.5	TEST SETUP.....	78



A D T

5.2.6	EUT OPERATING CONDITIONS .....	78
5.2.7	TEST RESULTS .....	79
5.3	6dB BANDWIDTH MEASUREMENT .....	83
5.3.1	LIMITS OF 6dB BANDWIDTH MEASUREMENT .....	83
5.3.2	TEST SETUP .....	83
5.3.3	TEST INSTRUMENTS.....	83
5.3.4	TEST PROCEDURE.....	83
5.3.5	DEVIATION FROM TEST STANDARD.....	83
5.3.6	EUT OPERATING CONDITIONS .....	83
5.3.7	TEST RESULTS .....	84
5.4	CONDUCTED OUTPUT POWER.....	85
5.4.1	LIMITS OF CONDUCTED OUTPUT POWER MEASUREMENT .....	85
5.4.2	TEST SETUP .....	85
5.4.3	INSTRUMENTS.....	85
5.4.4	TEST PROCEDURES .....	85
5.4.5	DEVIATION FROM TEST STANDARD.....	85
5.4.6	EUT OPERATING CONDITIONS .....	85
5.4.7	TEST RESULTS .....	86
5.5	POWER SPECTRAL DENSITY MEASUREMENT .....	88
5.5.1	LIMITS OF POWER SPECTRAL DENSITY MEASUREMENT .....	88
5.5.2	TEST SETUP.....	88
5.5.3	TEST INSTRUMENTS.....	88
5.5.4	TEST PROCEDURE.....	88
5.5.5	DEVIATION FROM TEST STANDARD.....	88
5.5.6	EUT OPERATING CONDITION.....	88
5.5.7	TEST RESULTS .....	89
5.6	CONDUCTED OUT OF BAND EMISSION MEASUREMENT .....	90
5.6.1	LIMITS OF CONDUCTED OUT OF BAND EMISSION MEASUREMENT .....	90
5.6.2	TEST SETUP.....	90
5.6.3	TEST INSTRUMENTS.....	90
5.6.4	TEST PROCEDURE.....	90
5.6.5	DEVIATION FROM TEST STANDARD.....	90
5.6.6	EUT OPERATING CONDITION.....	90
5.6.7	TEST RESULTS .....	90
6.	PHOTOGRAPHS OF THE TEST CONFIGURATION .....	97
7.	INFORMATION ON THE TESTING LABORATORIES .....	98
8.	APPENDIX A – MODIFICATIONS RECORDERS FOR ENGINEERING CHANGES TO THE EUT BY THE LAB.....	99



A D T

## RELEASE CONTROL RECORD

ISSUE NO.	REASON FOR CHANGE	DATE ISSUED
RF130726C17	Original release	Sep. 25, 2013



A D T

## 1. CERTIFICATION

**PRODUCT:** Single Radio 802.11a/b/g/n Indoor Access Point  
**MODEL NO.:** BW1253s  
**BRAND:** BROWAN  
**APPLICANT:** BROWAN COMMUNICATIONS Co., Ltd.  
**TESTED:** Aug. 02 ~ Sep. 17, 2013  
**TEST SAMPLE:** ENGINEERING SAMPLE  
**STANDARDS:** **FCC Part 15, Subpart C (Section 15.247)**  
ANSI C63.10-2009

The above equipment (model: BW1253s) has been tested by **Bureau Veritas Consumer Products Services (H.K.) Ltd., Taoyuan Branch**, and found compliance with the requirement of the above standards. The test record, data evaluation & Equipment Under Test (EUT) configurations represented herein are true and accurate accounts of the measurements of the sample's EMC characteristics under the conditions specified in this report.

**PREPARED BY:** Ivy Lin, **DATE:** Sep. 25, 2013

Ivy Lin / Specialist

**APPROVED BY:** Ken Liu, **DATE:** Sep. 25, 2013

Ken Liu / Senior Manager



## 2. SUMMARY OF TEST RESULTS

The EUT has been tested according to the following specifications:

APPLIED STANDARD: FCC PART 15, SUBPART C (SECTION 15.247)			
STANDARD SECTION	TEST TYPE	RESULT	REMARK
15.207	AC Power Conducted Emission	PASS	Meet the requirement of limit. Minimum passing margin is -8.34dB at 0.15000MHz
15.247(d) 15.209	Radiated Emissions	PASS	Meet the requirement of limit. Minimum passing margin is -1.0dB at 1608.00MHz, 2483.50MHz
15.247(d)	Band Edge Measurement	PASS	Meet the requirement of limit.
15.247(a)(2)	6dB bandwidth	PASS	Meet the requirement of limit.
15.247(b)	Conducted power	PASS	Meet the requirement of limit.
15.247(e)	Power Spectral Density	PASS	Meet the requirement of limit.
15.203	Antenna Requirement	PASS	Antenna connector is SMA-Male-RP not a standard connector.

### 2.1 MEASUREMENT UNCERTAINTY

Where relevant, the following measurement uncertainty levels have been estimated for tests performed on the EUT as specified in CISPR 16-4-2:

MEASUREMENT	FREQUENCY	UNCERTAINTY
Conducted emissions	9kHz~30MHz	2.44 dB
Radiated emissions	30MHz ~ 200MHz	2.93 dB
	200MHz ~1000MHz	2.95 dB
	1GHz ~ 18GHz	2.26 dB
	18GHz ~ 40GHz	1.94 dB

This uncertainty represents an expanded uncertainty expressed at approximately the 95% confidence level using a coverage factor of  $k = 2$ .



### 3. GENERAL INFORMATION

#### 3.1 GENERAL DESCRIPTION OF EUT

<b>EUT</b>	Single Radio 802.11a/b/g/n Indoor Access Point
<b>MODEL NO.</b>	BW1253s
<b>POWER SUPPLY</b>	12Vdc (Adapter) 48Vdc (POE)
<b>MODULATION TYPE</b>	CCK, DQPSK, DBPSK for DSSS 64QAM, 16QAM, QPSK, BPSK for OFDM
<b>MODULATION TECHNOLOGY</b>	DSSS, OFDM
<b>TRANSFER RATE</b>	802.11b:11.0/ 5.5/ 2.0/ 1.0Mbps 802.11g: 54.0/ 48.0/ 36.0/ 24.0/ 18.0/ 12.0/ 9.0/ 6.0Mbps 802.11a: 54.0/ 48.0/ 36.0/ 24.0/ 18.0/ 12.0/ 9.0/ 6.0Mbps 802.11n: up to 300.0Mbps
<b>OPERATING FREQUENCY</b>	<b>2.4GHz:</b> 2412 ~ 2462MHz <b>5.0GHz:</b> 5745 ~ 5825MHz
<b>NUMBER OF CHANNEL</b>	<b>2.4GHz:</b> 11 for 802.11b, 802.11g, 802.11n (20MHz) 7 for 802.11n (40MHz) <b>5.0GHz:</b> 5 for 802.11a, 802.11n (20MHz) 2 for 802.11n (40MHz)
<b>OUTPUT POWER</b>	654.989mW for 2412 ~ 2462MHz 684.156mW for 5745 ~ 5825MHz
<b>ANTENNA TYPE</b>	Dipole antenna with 2.0dBi gain
<b>ANTENNA CONNECTOR</b>	SMA-Male-RP
<b>DATA CABLE</b>	N/A
<b>I/O PORTS</b>	Refer to user's manual
<b>ACCESSORY DEVICES</b>	Adapter





A D T

**NOTE:**

1. The EUT incorporates a MIMO function. Physically, the EUT provides two completed transmitters and two receivers.

MODULATION MODE	TX FUNCTION
802.11b	2TX
802.11g	2TX
802.11a	2TX
802.11n (20MHz)	2TX
802.11n (40MHz)	2TX

2. The EUT consumes power from the following adapter.

<b>BRAND</b>	LEADER ELECTRONICS INC.
<b>MODEL</b>	MU18-R120150-A1
<b>INPUT POWER</b>	100-240Vac, 50/60Hz, 0.6A
<b>OUTPUT POWER</b>	12Vdc, 1.5A
<b>POWER LINE</b>	1.5m cable without core attached on adapter

3. The above EUT information is declared by manufacturer and for more detailed features description, please refer to the manufacturer's specifications or user's manual.



### 3.2 DESCRIPTION OF TEST MODES

#### FOR 2.4GHz:

11 channels are provided for 802.11b, 802.11g and 802.11n (20MHz):

CHANNEL	FREQUENCY	CHANNEL	FREQUENCY
1	2412MHz	7	2442MHz
2	2417MHz	8	2447MHz
3	2422MHz	9	2452MHz
4	2427MHz	10	2457MHz
5	2432MHz	11	2462MHz
6	2437MHz		

7 channels are provided for 802.11n (40MHz):

CHANNEL	FREQUENCY	CHANNEL	FREQUENCY
3	2422MHz	7	2442MHz
4	2427MHz	8	2447MHz
5	2432MHz	9	2452MHz
6	2437MHz		

#### FOR 5.0GHz (5745 ~ 5825MHz):

5 channels are provided for 802.11a, 802.11n (20MHz):

CHANNEL	FREQUENCY	CHANNEL	FREQUENCY
149	5745MHz	161	5805MHz
153	5765MHz	165	5825MHz
157	5785MHz		

2 channels are provided for 802.11n (40MHz):

CHANNEL	FREQUENCY	CHANNEL	FREQUENCY
151	5755MHz	159	5795MHz



### 3.2.1 TEST MODE APPLICABILITY AND TESTED CHANNEL DETAIL

#### FOR 2.4GHz:

EUT CONFIGURE MODE	APPLICABLE TO				DESCRIPTION
	RE≥1G	RE<1G	PLC	APCM	
A	√	√	√	√	Power from adapter
B	-	√	√	-	Power from POE

Where **RE≥1G**: Radiated Emission above 1GHz      **RE<1G**: Radiated Emission below 1GHz  
**PLC**: Power Line Conducted Emission      **APCM**: Antenna Port Conducted Measurement

**NOTE:**

1. The EUT had been pre-tested on the positioned of each 3 axis. The worst case was found when positioned on X-plane.
2. "-" means no effect.

#### **RADIATED EMISSION TEST (ABOVE 1GHz):**

- Pre-Scan has been conducted to determine the worst-case mode from all possible combinations between available modulations, data rates and antenna ports (if EUT with antenna diversity architecture).
- Following channel(s) was (were) selected for the final test as listed below.

EUT CONFIGURE MODE	MODE	AVAILABLE CHANNEL	TESTED CHANNEL	MODULATION TECHNOLOGY	MODULATION TYPE	DATA RATE (Mbps)
A	802.11b	1 to 11	1, 6, 11	DSSS	DBPSK	1.0
A	802.11g	1 to 11	1, 6, 11	OFDM	BPSK	6.0
A	802.11n (20MHz)	1 to 11	1, 6, 11	OFDM	BPSK	7.2
A	802.11n (40MHz)	3 to 9	3, 6, 9	OFDM	BPSK	15.0

#### **RADIATED EMISSION TEST (BELOW 1GHz):**

- Pre-Scan has been conducted to determine the worst-case mode from all possible combinations between available modulations, data rates and antenna ports (if EUT with antenna diversity architecture).
- Following channel(s) was (were) selected for the final test as listed below.

EUT CONFIGURE MODE	MODE	AVAILABLE CHANNEL	TESTED CHANNEL	MODULATION TECHNOLOGY	MODULATION TYPE	DATA RATE (Mbps)
A, B	802.11n (20MHz)	1 to 11	6	OFDM	BPSK	7.2

#### **POWER LINE CONDUCTED EMISSION TEST:**

- Pre-Scan has been conducted to determine the worst-case mode from all possible combinations between available modulations, data rates and antenna ports (if EUT with antenna diversity architecture).
- Following channel(s) was (were) selected for the final test as listed below.

EUT CONFIGURE MODE	MODE	AVAILABLE CHANNEL	TESTED CHANNEL	MODULATION TECHNOLOGY	MODULATION TYPE	DATA RATE (Mbps)
A, B	802.11n (20MHz)	1 to 11	6	OFDM	BPSK	7.2



**BANDEDGE MEASUREMENT:**

- Pre-Scan has been conducted to determine the worst-case mode from all possible combinations between available modulations, data rates and antenna ports (if EUT with antenna diversity architecture).
- Following channel(s) was (were) selected for the final test as listed below.

EUT CONFIGURE MODE	MODE	AVAILABLE CHANNEL	TESTED CHANNEL	MODULATION TECHNOLOGY	MODULATION TYPE	DATA RATE (Mbps)
A	802.11b	1 to 11	1, 11	DSSS	DBPSK	1.0
A	802.11g	1 to 11	1, 11	OFDM	BPSK	6.0
A	802.11n (20MHz)	1 to 11	1, 11	OFDM	BPSK	7.2
A	802.11n (40MHz)	3 to 9	3, 9	OFDM	BPSK	15.0

**ANTENNA PORT CONDUCTED MEASUREMENT:**

- This item includes all test value of each mode, but only includes spectrum plot of worst value of each mode.
- Pre-Scan has been conducted to determine the worst-case mode from all possible combinations between available modulations, data rates and antenna ports (if EUT with antenna diversity architecture).
- Following channel(s) was (were) selected for the final test as listed below.

EUT CONFIGURE MODE	MODE	AVAILABLE CHANNEL	TESTED CHANNEL	MODULATION TECHNOLOGY	MODULATION TYPE	DATA RATE (Mbps)
A	802.11b	1 to 11	1, 6, 11	DSSS	DBPSK	1.0
A	802.11g	1 to 11	1, 6, 11	OFDM	BPSK	6.0
A	802.11n (20MHz)	1 to 11	1, 6, 11	OFDM	BPSK	7.2
A	802.11n (40MHz)	3 to 9	3, 6, 9	OFDM	BPSK	15.0

**TEST CONDITION:**

APPLICABLE TO	ENVIRONMENTAL CONDITIONS	INPUT POWER	TESTED BY
RE≥1G	25deg. C, 65%RH	120Vac, 60Hz	Ted Chang
RE<1G	24deg. C, 66%RH	120Vac, 60Hz	Cedric Wu
PLC	23deg. C, 65%RH	120Vac, 60Hz	Brad Tung
APCM	25deg. C, 60%RH	120Vac, 60Hz	Nick Chen



**FOR 5.0GHz (5745 ~ 5825MHz):**

EUT CONFIGURE MODE	APPLICABLE TO				DESCRIPTION
	RE≥1G	RE<1G	PLC	APCM	
A	√	√	√	√	Power from adapter
B	-	√	√	-	Power from POE

Where **RE≥1G**: Radiated Emission above 1GHz      **RE<1G**: Radiated Emission below 1GHz  
**PLC**: Power Line Conducted Emission      **APCM**: Antenna Port Conducted Measurement

**NOTE:**

1. The EUT had been pre-tested on the positioned of each 3 axis. The worst case was found when positioned on X-plane.
2. "-" means no effect.

**RADIATED EMISSION TEST (ABOVE 1GHz):**

- Pre-Scan has been conducted to determine the worst-case mode from all possible combinations between available modulations, data rates and antenna ports (if EUT with antenna diversity architecture).
- Following channel(s) was (were) selected for the final test as listed below.

EUT CONFIGURE MODE	MODE	AVAILABLE CHANNEL	TESTED CHANNEL	MODULATION TECHNOLOGY	MODULATION TYPE	DATA RATE (Mbps)
A	802.11a	149 to 165	149, 157, 165	OFDM	BPSK	6.0
A	802.11n (20MHz)	149 to 165	149, 157, 165	OFDM	BPSK	7.2
A	802.11n (40MHz)	151 to 159	151, 159	OFDM	BPSK	15.0

**RADIATED EMISSION TEST (BELOW 1GHz):**

- Pre-Scan has been conducted to determine the worst-case mode from all possible combinations between available modulations, data rates and antenna ports (if EUT with antenna diversity architecture).
- Following channel(s) was (were) selected for the final test as listed below.

EUT CONFIGURE MODE	MODE	AVAILABLE CHANNEL	TESTED CHANNEL	MODULATION TECHNOLOGY	MODULATION TYPE	DATA RATE (Mbps)
A, B	802.11a	149 to 165	149,	OFDM	BPSK	6.0

**POWER LINE CONDUCTED EMISSION TEST:**

- Pre-Scan has been conducted to determine the worst-case mode from all possible combinations between available modulations, data rates and antenna ports (if EUT with antenna diversity architecture).
- Following channel(s) was (were) selected for the final test as listed below.

EUT CONFIGURE MODE	MODE	AVAILABLE CHANNEL	TESTED CHANNEL	MODULATION TECHNOLOGY	MODULATION TYPE	DATA RATE (Mbps)
A, B	802.11a	149 to 165	149,	OFDM	BPSK	6.0



**BANDEDGE MEASUREMENT:**

- Pre-Scan has been conducted to determine the worst-case mode from all possible combinations between available modulations, data rates and antenna ports (if EUT with antenna diversity architecture).
- Following channel(s) was (were) selected for the final test as listed below.

EUT CONFIGURE MODE	MODE	AVAILABLE CHANNEL	TESTED CHANNEL	MODULATION TECHNOLOGY	MODULATION TYPE	DATA RATE (Mbps)
A	802.11a	149 to 165	149, 165	OFDM	BPSK	6.0
A	802.11n (20MHz)	149 to 165	149, 165	OFDM	BPSK	7.2
A	802.11n (40MHz)	151 to 159	151, 159	OFDM	BPSK	15.0

**ANTENNA PORT CONDUCTED MEASUREMENT:**

- This item includes all test value of each mode, but only includes spectrum plot of worst value of each mode.
- Pre-Scan has been conducted to determine the worst-case mode from all possible combinations between available modulations, data rates and antenna ports (if EUT with antenna diversity architecture).
- Following channel(s) was (were) selected for the final test as listed below.

EUT CONFIGURE MODE	MODE	AVAILABLE CHANNEL	TESTED CHANNEL	MODULATION TECHNOLOGY	MODULATION TYPE	DATA RATE (Mbps)
A	802.11a	149 to 165	149, 157, 165	OFDM	BPSK	6.0
A	802.11n (20MHz)	149 to 165	149, 157, 165	OFDM	BPSK	7.2
A	802.11n (40MHz)	151 to 159	151, 159	OFDM	BPSK	15.0

**TEST CONDITION:**

APPLICABLE TO	ENVIRONMENTAL CONDITIONS	INPUT POWER	TESTED BY
RE≥1G	25deg. C, 65%RH	120Vac, 60Hz	Ted Chang
RE<1G	24deg. C, 66%RH, 25deg. C, 65%RH	120Vac, 60Hz	Cedric Wu, Ted Chang
PLC	23deg. C, 65%RH	120Vac, 60Hz	Brad Tung
APCM	25deg. C, 60%RH	120Vac, 60Hz	Nick Chen



A D T

### 3.3 DUTY CYCLE OF TEST SIGNAL

#### 2.4GHz:

Duty cycle of test signal is > 98 %, duty factor is not required.

**802.11b:** Duty cycle > 98 %

**802.11g:** Duty cycle =  $3.142500/3.156250 = 0.996$

**802.11n (20MHz):** Duty cycle =  $2.918750/2.932500 = 0.995$

**802.11n (40MHz):** Duty cycle =  $1.430000/1.443750 = 0.990$

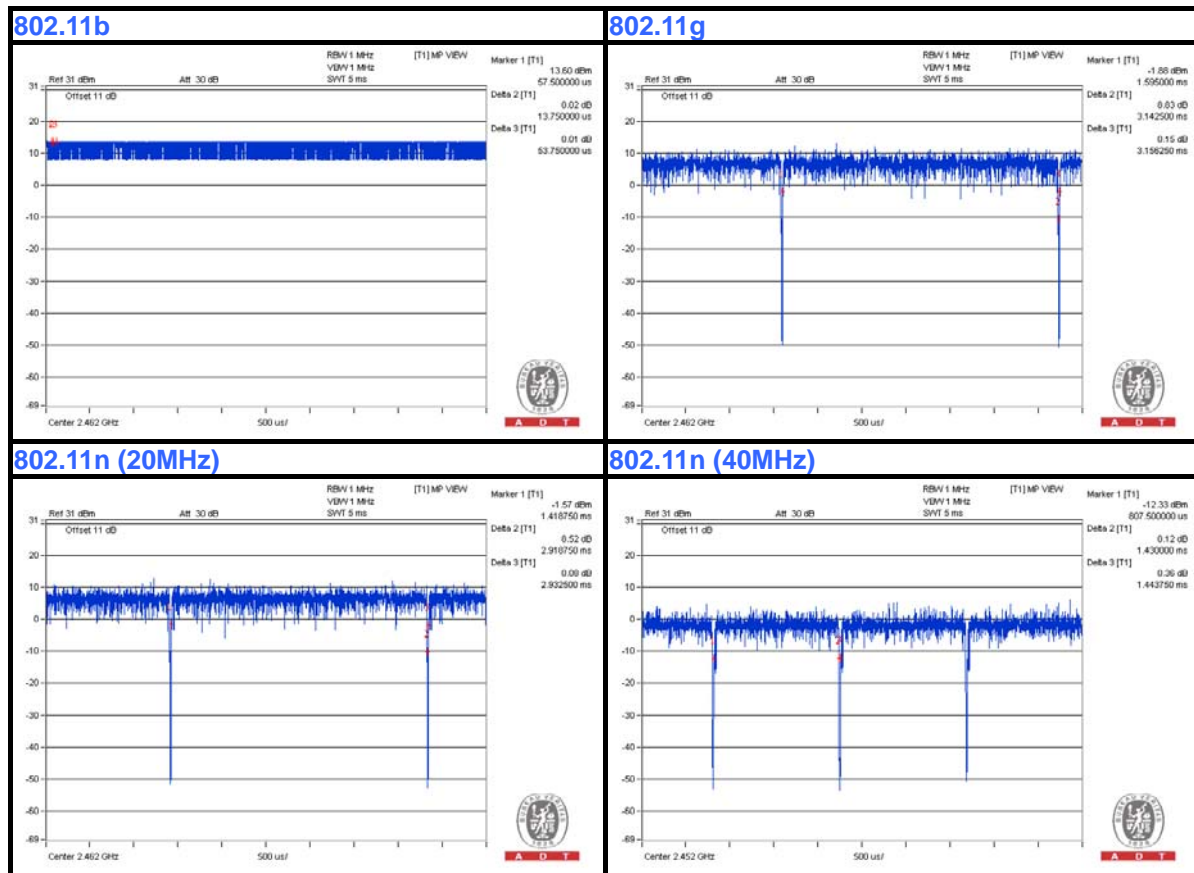



A D T

### 5.0GHz:

Duty cycle of test signal is > 98 %, duty factor is not required.

**802.11a:** Duty cycle =  $3.132500/3.152500 = 0.994$

**802.11n (20MHz):** Duty cycle =  $2.907500/2.925000 = 0.994$

**802.11n (40MHz):** Duty cycle =  $1.422500/1.437500 = 0.990$

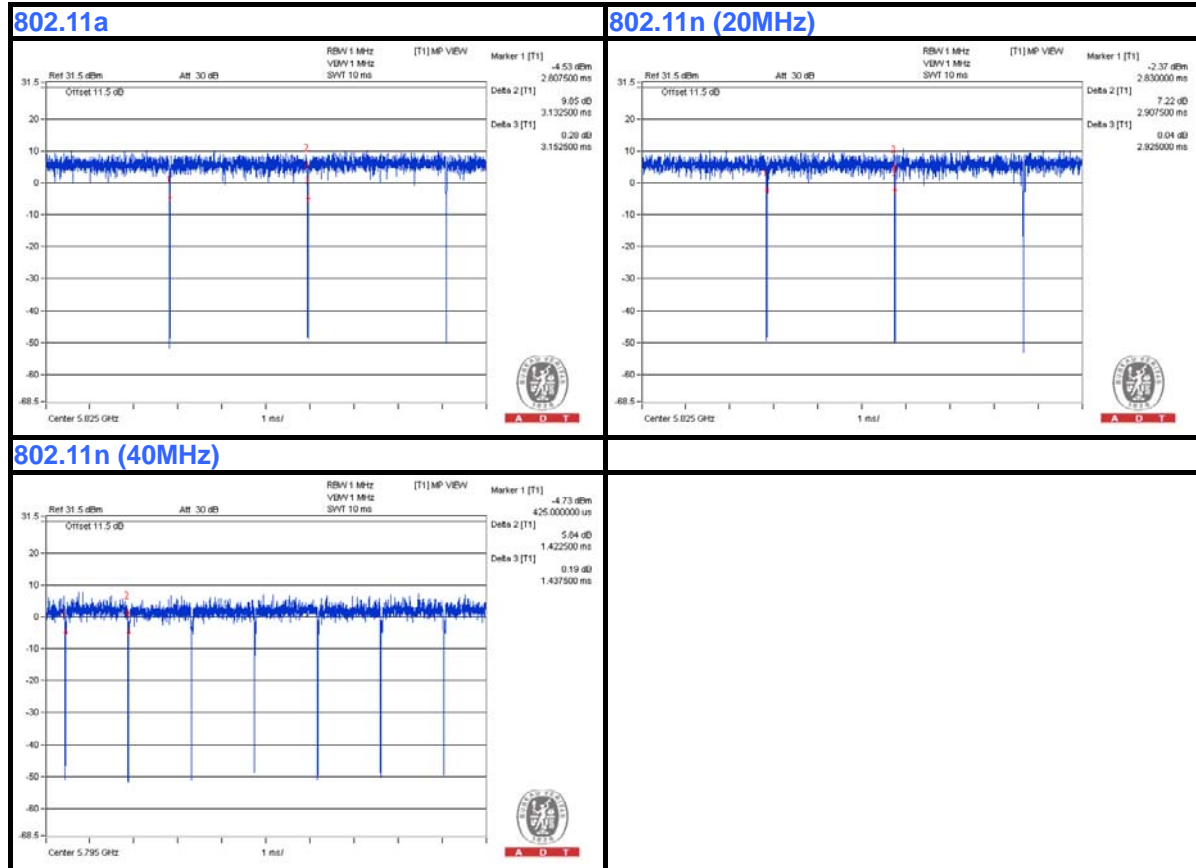





A D T

### 3.4 DESCRIPTION OF SUPPORT UNITS

The EUT has been tested as an independent unit together with other necessary accessories or support units. The following support units or accessories were used to form a representative test configuration during the tests.

NO.	PRODUCT	BRAND	MODEL NO.	SERIAL NO.	FCC ID
1	Notebook	DELL	D531	CN-0XM006-48643-8 1U-2610	QDS-BRCM1020
2	USB Flash Device	SANDISK	SDCZ6-1024	NA	FCC DoC Approved
3	POE	BROWAN	BE3013	NA	NA
4	Adapter	LEADER ELECTRONICS INC.	MU24-B48005 0-A1	NA	NA

NO.	SIGNAL CABLE DESCRIPTION OF THE ABOVE SUPPORT UNITS
1	10m RJ45 UTP cable
2	NA
3	10m RJ45 UTP cable, 1.8m RJ45 UTP cable
4	NA

**NOTE:**

- 1. All power cords of the above support units are non-shielded (1.8m).
- 2. Item 1 acted as a communication partner to transfer data.
- 3. Item 3 & 4 are provided by the client.

### 3.4.1 CONFIGURATION OF SYSTEM UNDER TEST

#### Test Mode A

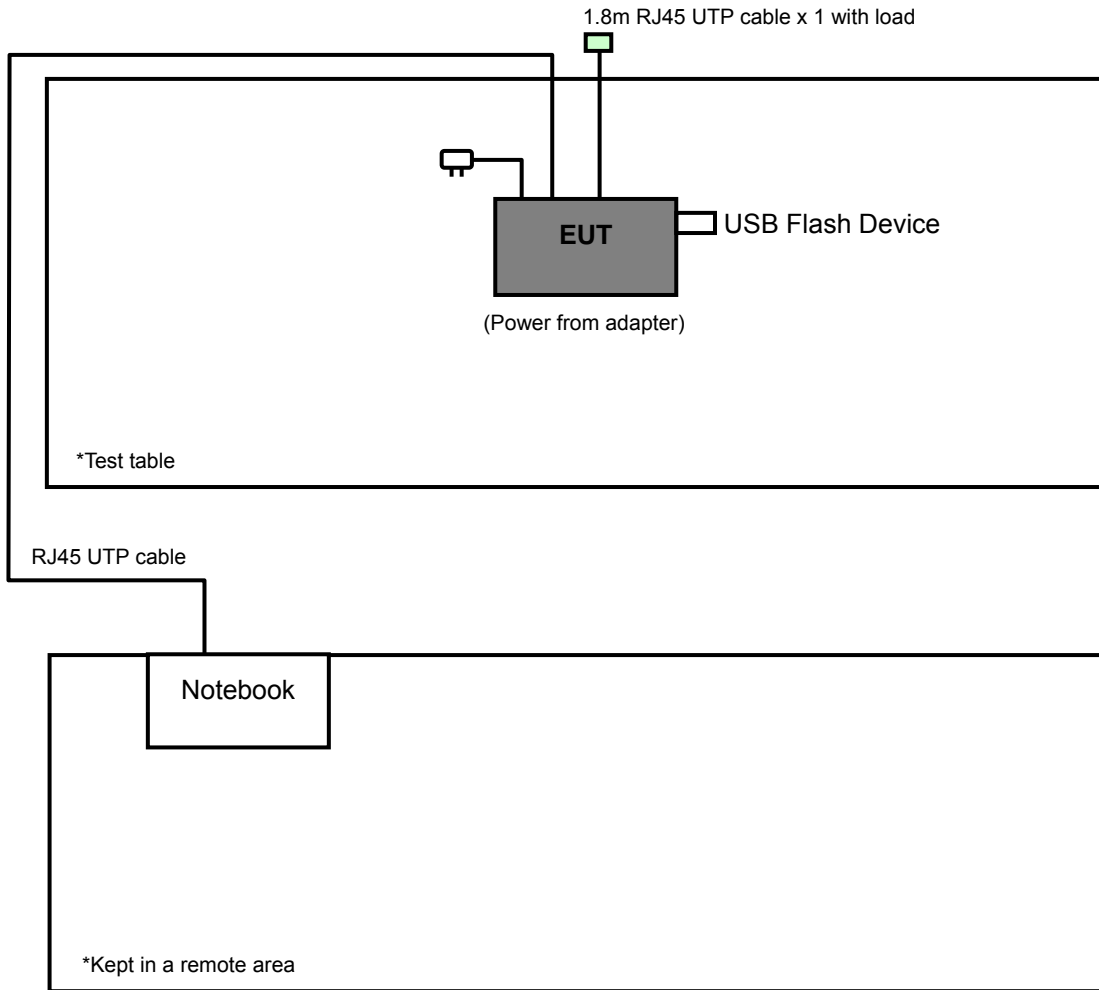

### Test Mode B

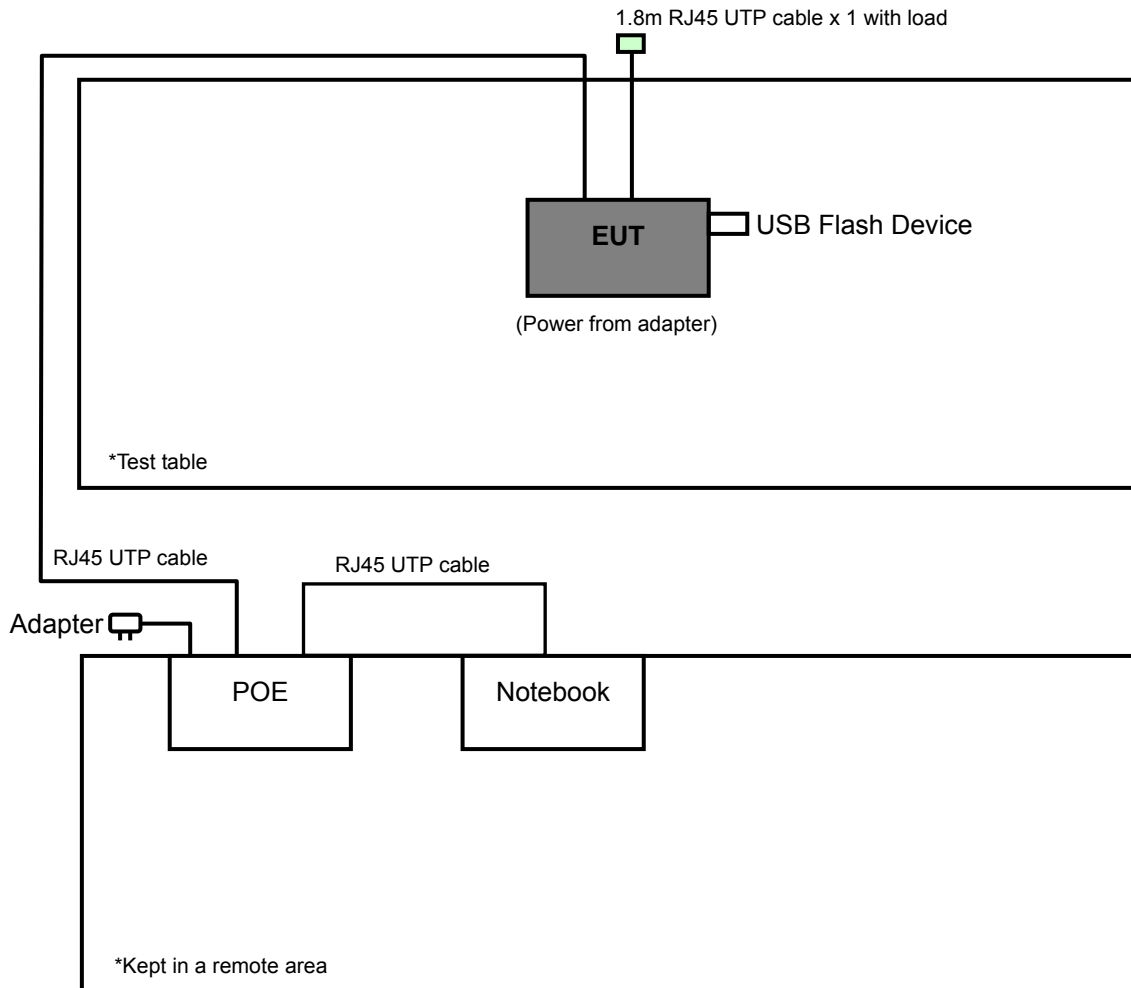



A D T

### 3.5 GENERAL DESCRIPTION OF APPLIED STANDARDS

The EUT is a RF Product. According to the specifications of the manufacturer, it must comply with the requirements of the following standards:

**FCC Part 15, Subpart C (15.247)**

**558074 D01 DTS Meas Guidance v03r01**

**662911 D01 Multiple Transmitter Output v01 r02**

**ANSI C63.10-2009**

All test items have been performed and recorded as per the above standards.

**NOTE:** The EUT is also considered as a kind of computer peripheral, because the connection to computer is necessary for typical use. It has been verified to comply with the requirements of FCC Part 15, Subpart B, Class B (DoC). The test report has been issued separately.



## 4. TEST TYPES AND RESULTS (FOR 2.4GHz BAND)

### 4.1 RADIATED EMISSION AND BANDEDGE MEASUREMENT

#### 4.1.1 LIMITS OF RADIATED EMISSION AND BANDEDGE MEASUREMENT

Radiated emissions which fall in the restricted bands must comply with the radiated emission limits specified as below table. Other emissions shall be at least 20dB below the highest level of the desired power:

FREQUENCIES (MHz)	FIELD STRENGTH (microvolts/meter)	MEASUREMENT DISTANCE (meters)
0.009 ~ 0.490	2400/F(kHz)	300
0.490 ~ 1.705	24000/F(kHz)	30
1.705 ~ 30.0	30	30
30 ~ 88	100	3
88 ~ 216	150	3
216 ~ 960	200	3
Above 960	500	3

**NOTE:**

1. The lower limit shall apply at the transition frequencies.
2. Emission level (dBuV/m) = 20 log Emission level (uV/m).
3. For frequencies above 1000MHz, the field strength limits are based on average detector, however, the peak field strength of any emission shall not exceed the maximum permitted average limits, specified above by more than 20dB under any condition of modulation.



A D T

#### 4.1.2 TEST INSTRUMENTS

DESCRIPTION & MANUFACTURER	MODEL NO.	SERIAL NO.	DATE OF CALIBRATION	DUE DATE OF CALIBRATION
Test Receiver ROHDE & SCHWARZ	ESCS30	100289	Nov. 16, 2012	Nov. 15, 2013
Spectrum Analyzer ROHDE & SCHWARZ	FSP40	100269	Jan. 28, 2013	Jan. 27, 2014
BILOG Antenna SCHWARZBECK	VULB9168	9168-156	Mar. 22, 2013	Mar. 21, 2014
HORN Antenna SCHWARZBECK	BBHA 9120D	9120D-404	Dec. 22, 2012	Dec. 21, 2013
HORN Antenna SCHWARZBECK	BBHA 9170	148	Jul. 15, 2013	Jul. 14, 2014
Preamplifier Agilent	8449B	3008A01911	Oct. 25, 2012	Oct. 24, 2013
Preamplifier Agilent	8447D	2944A10638	Oct. 25, 2012	Oct. 24, 2013
RF signal cable HUBER+SUHNNER	SUCOFLEX 104	309222/4 248780/4 274392/4	Aug. 22, 2013	Aug. 21, 2014
RF signal cable Worken	8D-FB	Cable-HYCH9-01	Aug. 11, 2013	Aug. 10, 2014
Software BV ADT	ADT_Radiated_ V7.6.15.9.4	NA	NA	NA
Antenna Tower EMCO	2070/2080	512.835.4684	NA	NA
Turn Table EMCO	2087-2.03	NA	NA	NA
Antenna Tower & Turn Table Controller EMCO	2090	NA	NA	NA
26GHz ~ 40GHz Amplifier	EM26400	815221	Oct. 25, 2012	Oct. 24, 2013
High Speed Peak Power Meter	ML2495A	0824011	Jul. 29, 2013	Jul. 28, 2014
Power Sensor	MA2411B	0738171	Jul. 29, 2013	Jul. 28, 2014

- NOTE:** 1. The calibration interval of the above test instruments is 12 months and the calibrations are traceable to NML/ROC and NIST/USA.
2. The test was performed in HwaYa Chamber 9.
3. The horn antenna and HP preamplifier (model: 8449B) are used only for the measurement of emission frequency above 1GHz if tested.
4. The FCC Site Registration No. is 215374.
5. The IC Site Registration No. is IC 7450F-9.



A D T

#### 4.1.3 TEST PROCEDURES

- a. The EUT was placed on the top of a rotating table 0.8 meters above the ground at a 3 meters semi-anechoic chamber. The table was rotated 360 degrees to determine the position of the highest radiation.
- b. The EUT was set 3 meters away from the interference-receiving antenna, which was mounted on the top of a variable-height antenna tower.
- c. The antenna is a broadband antenna, and its height is varied from one meter to four meters above the ground to determine the maximum value of the field strength. Both horizontal and vertical polarizations of the antenna are set to make the measurement.
- d. For each suspected emission, the EUT was arranged to its worst case and then the antenna was tuned to heights from 1 meter to 4 meters and the rotatable table was turned from 0 degrees to 360 degrees to find the maximum reading.
- e. The test-receiver system was set to Peak Detect Function and Specified Bandwidth with Maximum Hold Mode.
- f. If the emission level of the EUT in peak mode was lower than the limit specified, then testing could be stopped and the peak values of the EUT would be reported. Otherwise the emissions would be re-tested one by one using peak, quasi-peak or average method as specified and then reported in a data sheet.

**NOTE:**

1. The resolution bandwidth and video bandwidth of test receiver/spectrum analyzer is 120kHz for Quasi-peak detection at frequency below 1GHz.
2. The resolution bandwidth of test receiver/spectrum analyzer is 1MHz and video bandwidth is 3MHz for Peak detection at frequency above 1GHz.
3. The resolution bandwidth of test receiver/spectrum analyzer is 1MHz and the video bandwidth is 1kHz(Duty cycle < 98%) or 10Hz(Duty cycle > 98%) for Average detection (AV) at frequency above 1GHz.
4. All modes of operation were investigated and the worst-case emissions are reported.

#### 4.1.4 DEVIATION FROM TEST STANDARD

No deviation.

### 4.1.5 TEST SETUP

#### Frequency range 30MHz~1GHz

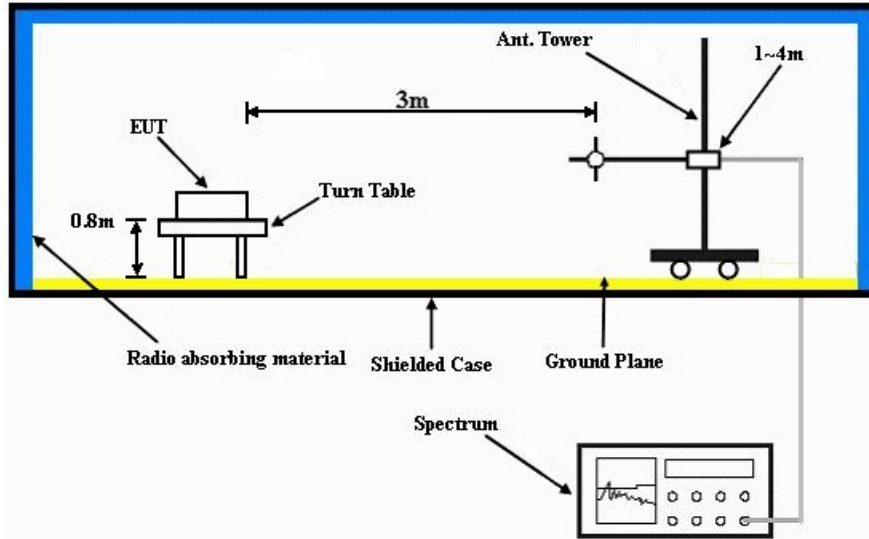

#### Frequency range above 1GHz

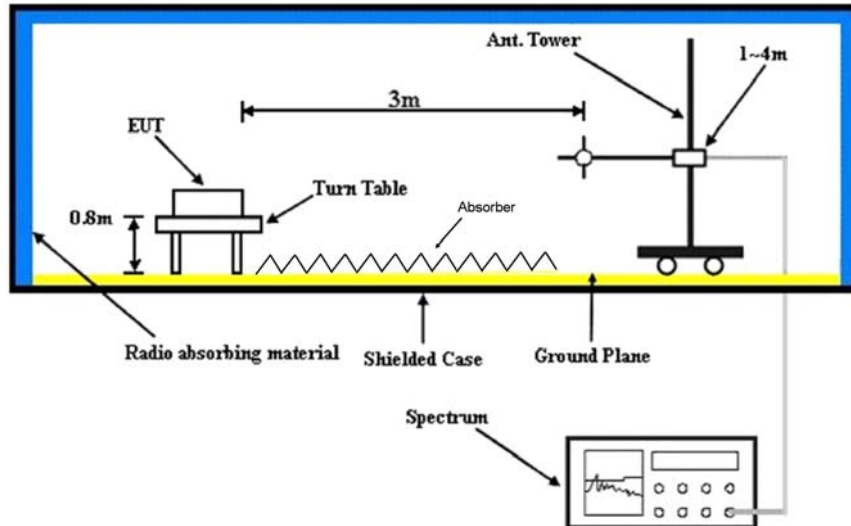

For the actual test configuration, please refer to the attached file (Test Setup Photo).





A D T

#### 4.1.6 EUT OPERATING CONDITIONS

- a. Placed the EUT on the testing table.
- b. Prepared notebooks to act as communication partner and placed it outside of testing area.
- c. The communication partner connected with EUT via a RJ45 cable and ran a test program (provided by manufacturer) to enable EUT under transmission condition continuously at specific channel frequency.
- d. The communication partner sent data to EUT by command "PING".
- e. The necessary accessories enabled the system in full functions.



A D T

#### 4.1.7 TEST RESULTS

#### ABOVE 1GHz DATA :

#### 802.11b

EUT TEST CONDITION		MEASUREMENT DETAIL	
CHANNEL	Channel 1	FREQUENCY RANGE	1 ~ 25GHz
INPUT POWER (SYSTEM)	120Vac, 60 Hz	DETECTOR FUNCTION	Peak (PK) Average (AV)
ENVIRONMENTAL CONDITIONS	25deg. C, 65%RH	TESTED BY	Ted Chang

ANTENNA POLARITY & TEST DISTANCE: HORIZONTAL AT 3 M								
NO.	FREQ. (MHz)	EMISSION LEVEL (dBuV/m)	LIMIT (dBuV/m)	MARGIN (dB)	ANTENNA HEIGHT (m)	TABLE ANGLE (Degree)	RAW VALUE (dBuV)	CORRECTION FACTOR (dB/m)
1	2390.00	59.0 PK	74.0	-15.0	1.00 H	205	25.60	33.40
2	2390.00	48.7 AV	54.0	-5.3	1.00 H	205	15.30	33.40
3	*2412.00	103.5 PK			1.00 H	167	70.00	33.50
4	*2412.00	99.9 AV			1.00 H	167	66.40	33.50
5	4924.00	51.8 PK	74.0	-22.2	1.26 H	78	47.90	3.90
6	4924.00	43.2 AV	54.0	-10.8	1.26 H	78	39.30	3.90
ANTENNA POLARITY & TEST DISTANCE: VERTICAL AT 3 M								
NO.	FREQ. (MHz)	EMISSION LEVEL (dBuV/m)	LIMIT (dBuV/m)	MARGIN (dB)	ANTENNA HEIGHT (m)	TABLE ANGLE (Degree)	RAW VALUE (dBuV)	CORRECTION FACTOR (dB/m)
1	1608.00	59.1 PK	74.0	-14.9	1.06 V	51	28.70	30.40
2	1608.00	53.0 AV	54.0	-1.0	1.06 V	51	22.60	30.40
3	2390.00	61.6 PK	74.0	-12.4	1.16 V	154	28.20	33.40
4	2390.00	51.9 AV	54.0	-2.1	1.16 V	154	18.50	33.40
5	*2412.00	109.8 PK			1.00 V	147	76.30	33.50
6	*2412.00	106.0 AV			1.00 V	147	72.50	33.50
7	4824.00	53.6 PK	74.0	-20.4	1.03 V	215	50.00	3.60
8	4824.00	48.6 AV	54.0	-5.4	1.03 V	215	45.00	3.60

#### REMARKS:

- Emission Level(dBuV/m) = Raw Value(dBuV) + Correction Factor(dB/m)
- Correction Factor(dB/m) = Antenna Factor(dB/m) + Cable Factor(dB)  
– Pre-Amplifier Factor(dB)
- The other emission levels were very low against the limit.
- Margin value = Emission Level – Limit value
- \* \* \*: Fundamental frequency.



A D T

EUT TEST CONDITION		MEASUREMENT DETAIL	
CHANNEL	Channel 6	FREQUENCY RANGE	1 ~ 25GHz
INPUT POWER (SYSTEM)	120Vac, 60 Hz	DETECTOR FUNCTION	Peak (PK) Average (AV)
ENVIRONMENTAL CONDITIONS	25deg. C, 65%RH	TESTED BY	Ted Chang

ANTENNA POLARITY & TEST DISTANCE: HORIZONTAL AT 3 M								
NO.	FREQ. (MHz)	EMISSION LEVEL (dBuV/m)	LIMIT (dBuV/m)	MARGIN (dB)	ANTENNA HEIGHT (m)	TABLE ANGLE (Degree)	RAW VALUE (dBuV)	CORRECTION FACTOR (dB/m)
1	1624.00	57.6 PK	74.0	-16.4	1.00 H	46	27.20	30.40
2	1624.00	50.5 AV	54.0	-3.5	1.00 H	46	20.10	30.40
3	*2437.00	107.0 PK			1.07 H	210	73.50	33.50
4	*2437.00	103.4 AV			1.07 H	210	69.90	33.50
5	4874.00	50.4 PK	74.0	-23.6	1.28 H	26	46.60	3.80
6	4874.00	41.7 AV	54.0	-12.3	1.28 H	26	37.90	3.80

ANTENNA POLARITY & TEST DISTANCE: VERTICAL AT 3 M								
NO.	FREQ. (MHz)	EMISSION LEVEL (dBuV/m)	LIMIT (dBuV/m)	MARGIN (dB)	ANTENNA HEIGHT (m)	TABLE ANGLE (Degree)	RAW VALUE (dBuV)	CORRECTION FACTOR (dB/m)
1	1624.00	59.1 PK	74.0	-14.9	1.00 V	311	28.70	30.40
2	1624.00	52.6 AV	54.0	-1.4	1.00 V	311	22.20	30.40
3	2288.00	60.5 PK	74.0	-13.5	1.00 V	148	27.30	33.20
4	2288.00	50.5 AV	54.0	-3.5	1.00 V	148	17.30	33.20
5	*2437.00	111.7 PK			1.13 V	157	78.20	33.50
6	*2437.00	108.1 AV			1.13 V	157	74.60	33.50
7	4874.00	54.4 PK	74.0	-19.6	1.00 V	216	50.60	3.80
8	4874.00	50.0 AV	54.0	-4.0	1.00 V	216	46.20	3.80

**REMARKS:**

1. Emission Level(dBuV/m) = Raw Value(dBuV) + Correction Factor(dB/m)
2. Correction Factor(dB/m) = Antenna Factor(dB/m) + Cable Factor(dB)  
– Pre-Amplifier Factor(dB)
3. The other emission levels were very low against the limit.
4. Margin value = Emission Level – Limit value
5. “ \* “: Fundamental frequency.



A D T

EUT TEST CONDITION		MEASUREMENT DETAIL	
CHANNEL	Channel 11	FREQUENCY RANGE	1 ~ 25GHz
INPUT POWER (SYSTEM)	120Vac, 60 Hz	DETECTOR FUNCTION	Peak (PK) Average (AV)
ENVIRONMENTAL CONDITIONS	25deg. C, 65%RH	TESTED BY	Ted Chang

ANTENNA POLARITY & TEST DISTANCE: HORIZONTAL AT 3 M								
NO.	FREQ. (MHz)	EMISSION LEVEL (dBuV/m)	LIMIT (dBuV/m)	MARGIN (dB)	ANTENNA HEIGHT (m)	TABLE ANGLE (Degree)	RAW VALUE (dBuV)	CORRECTION FACTOR (dB/m)
1	*2462.00	106.3 PK			1.04 H	208	72.70	33.60
2	*2462.00	102.4 AV			1.04 H	208	68.80	33.60
3	2483.50	59.1 PK	74.0	-14.9	1.00 H	205	25.40	33.70
4	2483.50	48.6 AV	54.0	-5.4	1.00 H	205	14.90	33.70
5	4924.00	50.8 PK	74.0	-23.2	1.01 H	215	46.90	3.90
6	4924.00	42.5 AV	54.0	-11.5	1.01 H	215	38.60	3.90
ANTENNA POLARITY & TEST DISTANCE: VERTICAL AT 3 M								
NO.	FREQ. (MHz)	EMISSION LEVEL (dBuV/m)	LIMIT (dBuV/m)	MARGIN (dB)	ANTENNA HEIGHT (m)	TABLE ANGLE (Degree)	RAW VALUE (dBuV)	CORRECTION FACTOR (dB/m)
1	*2462.00	112.5 PK			1.11 V	209	78.90	33.60
2	*2462.00	108.7 AV			1.11 V	209	75.10	33.60
3	2483.50	62.9 PK	74.0	-11.1	1.12 V	145	29.20	33.70
4	<b>2483.50</b>	<b>53.0 AV</b>	<b>54.0</b>	<b>-1.0</b>	<b>1.12 V</b>	<b>145</b>	<b>19.30</b>	<b>33.70</b>
5	4924.00	55.6 PK	74.0	-18.4	1.00 V	95	51.70	3.90
6	4924.00	51.9 AV	54.0	-2.1	1.00 V	95	48.00	3.90

**REMARKS:**

1. Emission Level(dBuV/m) = Raw Value(dBuV) + Correction Factor(dB/m)
2. Correction Factor(dB/m) = Antenna Factor(dB/m) + Cable Factor(dB)  
– Pre-Amplifier Factor(dB)
3. The other emission levels were very low against the limit.
4. Margin value = Emission Level – Limit value
5. “ \* “: Fundamental frequency.



A D T

802.11g

EUT TEST CONDITION		MEASUREMENT DETAIL	
CHANNEL	Channel 1	FREQUENCY RANGE	1 ~ 25GHz
INPUT POWER (SYSTEM)	120Vac, 60 Hz	DETECTOR FUNCTION	Peak (PK) Average (AV)
ENVIRONMENTAL CONDITIONS	25deg. C, 65%RH	TESTED BY	Ted Chang

ANTENNA POLARITY & TEST DISTANCE: HORIZONTAL AT 3 M								
NO.	FREQ. (MHz)	EMISSION LEVEL (dBuV/m)	LIMIT (dBuV/m)	MARGIN (dB)	ANTENNA HEIGHT (m)	TABLE ANGLE (Degree)	RAW VALUE (dBuV)	CORRECTION FACTOR (dB/m)
1	2390.00	59.8 PK	74.0	-14.2	1.00 H	206	26.40	33.40
2	2390.00	47.9 AV	54.0	-6.1	1.00 H	206	14.50	33.40
3	*2412.00	102.9 PK			1.29 H	180	69.40	33.50
4	*2412.00	93.7 AV			1.29 H	180	60.20	33.50
5	4824.00	48.9 PK	74.0	-25.1	1.23 H	241	45.30	3.60
6	4824.00	34.8 AV	54.0	-19.2	1.23 H	241	31.20	3.60

ANTENNA POLARITY & TEST DISTANCE: VERTICAL AT 3 M								
NO.	FREQ. (MHz)	EMISSION LEVEL (dBuV/m)	LIMIT (dBuV/m)	MARGIN (dB)	ANTENNA HEIGHT (m)	TABLE ANGLE (Degree)	RAW VALUE (dBuV)	CORRECTION FACTOR (dB/m)
1	2288.00	61.1 PK	74.0	-12.9	1.00 V	149	27.90	33.20
2	2288.00	51.5 AV	54.0	-2.5	1.00 V	149	18.30	33.20
3	2390.00	70.0 PK	74.0	-4.0	1.16 V	154	36.60	33.40
4	2390.00	51.7 AV	54.0	-2.3	1.16 V	154	18.30	33.40
5	*2412.00	109.4 PK			1.00 V	147	75.90	33.50
6	*2412.00	99.7 AV			1.00 V	147	66.20	33.50
7	4824.00	50.4 PK	74.0	-23.6	1.00 V	184	46.80	3.60
8	4824.00	36.7 AV	54.0	-17.3	1.00 V	184	33.10	3.60

REMARKS:

1. Emission Level(dBuV/m) = Raw Value(dBuV) + Correction Factor(dB/m)
2. Correction Factor(dB/m) = Antenna Factor(dB/m) + Cable Factor(dB) – Pre-Amplifier Factor(dB)
3. The other emission levels were very low against the limit.
4. Margin value = Emission Level – Limit value
5. “ \* “: Fundamental frequency.



A D T

EUT TEST CONDITION		MEASUREMENT DETAIL	
CHANNEL	Channel 6	FREQUENCY RANGE	1 ~ 25GHz
INPUT POWER (SYSTEM)	120Vac, 60 Hz	DETECTOR FUNCTION	Peak (PK) Average (AV)
ENVIRONMENTAL CONDITIONS	25deg. C, 65%RH	TESTED BY	Ted Chang

ANTENNA POLARITY & TEST DISTANCE: HORIZONTAL AT 3 M								
NO.	FREQ. (MHz)	EMISSION LEVEL (dBuV/m)	LIMIT (dBuV/m)	MARGIN (dB)	ANTENNA HEIGHT (m)	TABLE ANGLE (Degree)	RAW VALUE (dBuV)	CORRECTION FACTOR (dB/m)
1	*2437.00	103.7 PK			1.00 H	208	70.20	33.50
2	*2437.00	94.3 AV			1.00 H	208	60.80	33.50
3	4874.00	47.4 PK	74.0	-26.6	1.02 H	357	43.60	3.80
4	4874.00	35.0 AV	54.0	-19.0	1.02 H	357	31.20	3.80
ANTENNA POLARITY & TEST DISTANCE: VERTICAL AT 3 M								
NO.	FREQ. (MHz)	EMISSION LEVEL (dBuV/m)	LIMIT (dBuV/m)	MARGIN (dB)	ANTENNA HEIGHT (m)	TABLE ANGLE (Degree)	RAW VALUE (dBuV)	CORRECTION FACTOR (dB/m)
1	2288.00	61.9 PK	74.0	-12.1	1.00 V	147	28.70	33.20
2	2288.00	51.3 AV	54.0	-2.7	1.00 V	147	18.10	33.20
3	*2437.00	110.2 PK			1.12 V	155	76.70	33.50
4	*2437.00	100.6 AV			1.12 V	155	67.10	33.50
5	4874.00	50.7 PK	74.0	-23.3	1.32 V	241	46.90	3.80
6	4874.00	37.8 AV	54.0	-16.2	1.32 V	241	34.00	3.80

**REMARKS:**

1. Emission Level(dBuV/m) = Raw Value(dBuV) + Correction Factor(dB/m)
2. Correction Factor(dB/m) = Antenna Factor(dB/m) + Cable Factor(dB) – Pre-Amplifier Factor(dB)
3. The other emission levels were very low against the limit.
4. Margin value = Emission Level – Limit value
5. “ \* “: Fundamental frequency.



A D T

EUT TEST CONDITION		MEASUREMENT DETAIL	
CHANNEL	Channel 11	FREQUENCY RANGE	1 ~ 25GHz
INPUT POWER (SYSTEM)	120Vac, 60 Hz	DETECTOR FUNCTION	Peak (PK) Average (AV)
ENVIRONMENTAL CONDITIONS	25deg. C, 65%RH	TESTED BY	Ted Chang

ANTENNA POLARITY & TEST DISTANCE: HORIZONTAL AT 3 M								
NO.	FREQ. (MHz)	EMISSION LEVEL (dBuV/m)	LIMIT (dBuV/m)	MARGIN (dB)	ANTENNA HEIGHT (m)	TABLE ANGLE (Degree)	RAW VALUE (dBuV)	CORRECTION FACTOR (dB/m)
1	*2462.00	104.1 PK			1.03 H	210	70.50	33.60
2	*2462.00	94.6 AV			1.03 H	210	61.00	33.60
3	2483.50	64.0 PK	74.0	-10.0	1.00 H	184	30.30	33.70
4	2483.50	49.1 AV	54.0	-4.9	1.00 H	184	15.40	33.70
5	4924.00	48.2 PK	74.0	-25.8	1.00 H	128	44.30	3.90
6	4924.00	35.1 AV	54.0	-18.9	1.00 H	128	31.20	3.90

ANTENNA POLARITY & TEST DISTANCE: VERTICAL AT 3 M								
NO.	FREQ. (MHz)	EMISSION LEVEL (dBuV/m)	LIMIT (dBuV/m)	MARGIN (dB)	ANTENNA HEIGHT (m)	TABLE ANGLE (Degree)	RAW VALUE (dBuV)	CORRECTION FACTOR (dB/m)
1	2288.00	61.2 PK	74.0	-12.8	1.00 V	147	28.00	33.20
2	2288.00	51.2 AV	54.0	-2.8	1.00 V	147	18.00	33.20
3	*2462.00	110.0 PK			1.12 V	220	76.40	33.60
4	*2462.00	100.6 AV			1.12 V	220	67.00	33.60
5	2483.50	72.0 PK	74.0	-2.0	1.14 V	145	38.30	33.70
6	2483.50	52.3 AV	54.0	-1.7	1.14 V	145	18.60	33.70
7	4924.00	51.4 PK	74.0	-22.6	1.25 V	159	47.50	3.90
8	4924.00	37.5 AV	54.0	-16.5	1.25 V	159	33.60	3.90

**REMARKS:**

1. Emission Level(dBuV/m) = Raw Value(dBuV) + Correction Factor(dB/m)
2. Correction Factor(dB/m) = Antenna Factor(dB/m) + Cable Factor(dB)  
– Pre-Amplifier Factor(dB)
3. The other emission levels were very low against the limit.
4. Margin value = Emission Level – Limit value
5. “ \* “: Fundamental frequency.



A D T

802.11n (20MHz)

EUT TEST CONDITION		MEASUREMENT DETAIL	
CHANNEL	Channel 1	FREQUENCY RANGE	1 ~ 25GHz
INPUT POWER (SYSTEM)	120Vac, 60 Hz	DETECTOR FUNCTION	Peak (PK) Average (AV)
ENVIRONMENTAL CONDITIONS	25deg. C, 65%RH	TESTED BY	Ted Chang

ANTENNA POLARITY & TEST DISTANCE: HORIZONTAL AT 3 M								
NO.	FREQ. (MHz)	EMISSION LEVEL (dBuV/m)	LIMIT (dBuV/m)	MARGIN (dB)	ANTENNA HEIGHT (m)	TABLE ANGLE (Degree)	RAW VALUE (dBuV)	CORRECTION FACTOR (dB/m)
1	2390.00	60.1 PK	74.0	-13.9	1.00 H	205	26.70	33.40
2	2390.00	48.6 AV	54.0	-5.4	1.00 H	205	15.20	33.40
3	*2412.00	102.7 PK			1.28 H	180	69.20	33.50
4	*2412.00	93.3 AV			1.28 H	180	59.80	33.50
5	4924.00	50.7 PK	74.0	-23.3	1.65 H	152	46.80	3.90
6	4924.00	35.1 AV	54.0	-18.9	1.65 H	152	31.20	3.90

ANTENNA POLARITY & TEST DISTANCE: VERTICAL AT 3 M								
NO.	FREQ. (MHz)	EMISSION LEVEL (dBuV/m)	LIMIT (dBuV/m)	MARGIN (dB)	ANTENNA HEIGHT (m)	TABLE ANGLE (Degree)	RAW VALUE (dBuV)	CORRECTION FACTOR (dB/m)
1	2288.00	61.2 PK	74.0	-12.8	1.00 V	149	28.00	33.20
2	2288.00	51.1 AV	54.0	-2.9	1.00 V	149	17.90	33.20
3	2390.00	72.9 PK	74.0	-1.1	1.17 V	154	39.50	33.40
4	2390.00	52.9 AV	54.0	-1.1	1.17 V	154	19.50	33.40
5	*2412.00	109.3 PK			1.00 V	148	75.80	33.50
6	*2412.00	99.4 AV			1.00 V	148	65.90	33.50
7	4824.00	49.8 PK	74.0	-24.2	1.00 V	241	46.20	3.60
8	4824.00	37.1 AV	54.0	-16.9	1.00 V	241	33.50	3.60

REMARKS:

1. Emission Level(dBuV/m) = Raw Value(dBuV) + Correction Factor(dB/m)
2. Correction Factor(dB/m) = Antenna Factor(dB/m) + Cable Factor(dB) – Pre-Amplifier Factor(dB)
3. The other emission levels were very low against the limit.
4. Margin value = Emission Level – Limit value
5. “ \* “: Fundamental frequency.





A D T

EUT TEST CONDITION		MEASUREMENT DETAIL	
CHANNEL	Channel 6	FREQUENCY RANGE	1 ~ 25GHz
INPUT POWER (SYSTEM)	120Vac, 60 Hz	DETECTOR FUNCTION	Peak (PK) Average (AV)
ENVIRONMENTAL CONDITIONS	25deg. C, 65%RH	TESTED BY	Ted Chang

ANTENNA POLARITY & TEST DISTANCE: HORIZONTAL AT 3 M								
NO.	FREQ. (MHz)	EMISSION LEVEL (dBuV/m)	LIMIT (dBuV/m)	MARGIN (dB)	ANTENNA HEIGHT (m)	TABLE ANGLE (Degree)	RAW VALUE (dBuV)	CORRECTION FACTOR (dB/m)
1	*2437.00	103.5 PK			1.00 H	207	70.00	33.50
2	*2437.00	94.1 AV			1.00 H	207	60.60	33.50
3	4874.00	47.0 PK	74.0	-27.0	1.03 H	210	43.20	3.80
4	4874.00	34.8 AV	54.0	-19.2	1.03 H	210	31.00	3.80

ANTENNA POLARITY & TEST DISTANCE: VERTICAL AT 3 M								
NO.	FREQ. (MHz)	EMISSION LEVEL (dBuV/m)	LIMIT (dBuV/m)	MARGIN (dB)	ANTENNA HEIGHT (m)	TABLE ANGLE (Degree)	RAW VALUE (dBuV)	CORRECTION FACTOR (dB/m)
1	2288.00	61.7 PK	74.0	-12.3	1.00 V	148	28.50	33.20
2	2288.00	51.6 AV	54.0	-2.4	1.00 V	148	18.40	33.20
3	*2437.00	110.0 PK			1.12 V	154	76.50	33.50
4	*2437.00	100.3 AV			1.12 V	154	66.80	33.50
5	4874.00	50.9 PK	74.0	-23.1	1.02 V	327	47.10	3.80
6	4874.00	37.4 AV	54.0	-16.6	1.02 V	327	33.60	3.80

**REMARKS:**

1. Emission Level(dBuV/m) = Raw Value(dBuV) + Correction Factor(dB/m)
2. Correction Factor(dB/m) = Antenna Factor(dB/m) + Cable Factor(dB) – Pre-Amplifier Factor(dB)
3. The other emission levels were very low against the limit.
4. Margin value = Emission Level – Limit value
5. “ \* “: Fundamental frequency.



A D T

EUT TEST CONDITION		MEASUREMENT DETAIL	
CHANNEL	Channel 11	FREQUENCY RANGE	1 ~ 25GHz
INPUT POWER (SYSTEM)	120Vac, 60 Hz	DETECTOR FUNCTION	Peak (PK) Average (AV)
ENVIRONMENTAL CONDITIONS	25deg. C, 65%RH	TESTED BY	Ted Chang

ANTENNA POLARITY & TEST DISTANCE: HORIZONTAL AT 3 M								
NO.	FREQ. (MHz)	EMISSION LEVEL (dBuV/m)	LIMIT (dBuV/m)	MARGIN (dB)	ANTENNA HEIGHT (m)	TABLE ANGLE (Degree)	RAW VALUE (dBuV)	CORRECTION FACTOR (dB/m)
1	*2462.00	104.0 PK			1.03 H	211	70.40	33.60
2	*2462.00	94.3 AV			1.03 H	211	60.70	33.60
3	2483.50	64.1 PK	74.0	-9.9	1.00 H	183	30.40	33.70
4	2483.50	49.3 AV	54.0	-4.7	1.00 H	183	15.60	33.70
5	4924.00	49.3 PK	74.0	-24.7	1.69 H	265	45.40	3.90
6	4924.00	34.3 AV	54.0	-19.7	1.69 H	265	30.40	3.90

ANTENNA POLARITY & TEST DISTANCE: VERTICAL AT 3 M								
NO.	FREQ. (MHz)	EMISSION LEVEL (dBuV/m)	LIMIT (dBuV/m)	MARGIN (dB)	ANTENNA HEIGHT (m)	TABLE ANGLE (Degree)	RAW VALUE (dBuV)	CORRECTION FACTOR (dB/m)
1	2288.00	61.5 PK	74.0	-12.5	1.00 V	146	28.30	33.20
2	2288.00	51.6 AV	54.0	-2.4	1.00 V	146	18.40	33.20
3	*2462.00	109.9 PK			1.12 V	221	76.30	33.60
4	*2462.00	100.3 AV			1.12 V	221	66.70	33.60
5	2483.50	71.9 PK	74.0	-2.1	1.14 V	144	38.20	33.70
6	2483.50	52.5 AV	54.0	-1.5	1.14 V	144	18.80	33.70
7	4924.00	52.4 PK	74.0	-21.6	1.41 V	245	48.50	3.90
8	4924.00	38.1 AV	54.0	-15.9	1.41 V	245	34.20	3.90

**REMARKS:**

1. Emission Level(dBuV/m) = Raw Value(dBuV) + Correction Factor(dB/m)
2. Correction Factor(dB/m) = Antenna Factor(dB/m) + Cable Factor(dB)  
– Pre-Amplifier Factor(dB)
3. The other emission levels were very low against the limit.
4. Margin value = Emission Level – Limit value
5. “ \* “: Fundamental frequency.



A D T

802.11n (40MHz)

EUT TEST CONDITION		MEASUREMENT DETAIL	
CHANNEL	Channel 3	FREQUENCY RANGE	1 ~ 25GHz
INPUT POWER (SYSTEM)	120Vac, 60 Hz	DETECTOR FUNCTION	Peak (PK) Average (AV)
ENVIRONMENTAL CONDITIONS	25deg. C, 65%RH	TESTED BY	Ted Chang

ANTENNA POLARITY & TEST DISTANCE: HORIZONTAL AT 3 M								
NO.	FREQ. (MHz)	EMISSION LEVEL (dBuV/m)	LIMIT (dBuV/m)	MARGIN (dB)	ANTENNA HEIGHT (m)	TABLE ANGLE (Degree)	RAW VALUE (dBuV)	CORRECTION FACTOR (dB/m)
1	2390.00	62.2 PK	74.0	-11.8	1.00 H	180	28.80	33.40
2	2390.00	48.4 AV	54.0	-5.6	1.00 H	180	15.00	33.40
3	*2422.00	97.7 PK			1.04 H	187	64.20	33.50
4	*2422.00	88.0 AV			1.04 H	187	54.50	33.50
5	4844.00	48.3 PK	74.0	-25.7	1.00 H	214	44.60	3.70
6	4844.00	33.9 AV	54.0	-20.1	1.00 H	214	30.20	3.70

ANTENNA POLARITY & TEST DISTANCE: VERTICAL AT 3 M								
NO.	FREQ. (MHz)	EMISSION LEVEL (dBuV/m)	LIMIT (dBuV/m)	MARGIN (dB)	ANTENNA HEIGHT (m)	TABLE ANGLE (Degree)	RAW VALUE (dBuV)	CORRECTION FACTOR (dB/m)
1	2288.00	60.6 PK	74.0	-13.4	1.00 V	147	27.40	33.20
2	2288.00	49.8 AV	54.0	-4.2	1.00 V	147	16.60	33.20
3	2390.00	69.8 PK	74.0	-4.2	1.19 V	155	36.40	33.40
4	2390.00	52.8 AV	54.0	-1.2	1.19 V	155	19.40	33.40
5	*2422.00	103.9 PK			1.13 V	153	70.40	33.50
6	*2422.00	94.6 AV			1.13 V	153	61.10	33.50
7	4844.00	51.2 PK	74.0	-22.8	1.03 V	264	47.50	3.70
8	4844.00	37.2 AV	54.0	-16.8	1.03 V	264	33.50	3.70

REMARKS:

1. Emission Level(dBuV/m) = Raw Value(dBuV) + Correction Factor(dB/m)
2. Correction Factor(dB/m) = Antenna Factor(dB/m) + Cable Factor(dB) – Pre-Amplifier Factor(dB)
3. The other emission levels were very low against the limit.
4. Margin value = Emission Level – Limit value
5. “ \* “: Fundamental frequency.



A D T

EUT TEST CONDITION		MEASUREMENT DETAIL	
CHANNEL	Channel 6	FREQUENCY RANGE	1 ~ 25GHz
INPUT POWER (SYSTEM)	120Vac, 60 Hz	DETECTOR FUNCTION	Peak (PK) Average (AV)
ENVIRONMENTAL CONDITIONS	25deg. C, 65%RH	TESTED BY	Ted Chang

ANTENNA POLARITY & TEST DISTANCE: HORIZONTAL AT 3 M								
NO.	FREQ. (MHz)	EMISSION LEVEL (dBuV/m)	LIMIT (dBuV/m)	MARGIN (dB)	ANTENNA HEIGHT (m)	TABLE ANGLE (Degree)	RAW VALUE (dBuV)	CORRECTION FACTOR (dB/m)
1	*2437.00	101.0 PK			1.03 H	210	67.50	33.50
2	*2437.00	91.0 AV			1.03 H	210	57.50	33.50
3	4874.00	48.3 PK	74.0	-25.7	1.02 H	325	44.50	3.80
4	4874.00	34.0 AV	54.0	-20.0	1.02 H	325	30.20	3.80
ANTENNA POLARITY & TEST DISTANCE: VERTICAL AT 3 M								
NO.	FREQ. (MHz)	EMISSION LEVEL (dBuV/m)	LIMIT (dBuV/m)	MARGIN (dB)	ANTENNA HEIGHT (m)	TABLE ANGLE (Degree)	RAW VALUE (dBuV)	CORRECTION FACTOR (dB/m)
1	2288.00	60.7 PK	74.0	-13.3	1.00 V	149	27.50	33.20
2	2288.00	51.0 AV	54.0	-3.0	1.00 V	149	17.80	33.20
3	*2437.00	107.5 PK			1.13 V	155	74.00	33.50
4	*2437.00	97.2 AV			1.13 V	155	63.70	33.50
5	2483.50	66.1 PK	74.0	-7.9	1.00 V	227	32.40	33.70
6	2483.50	50.3 AV	54.0	-3.7	1.00 V	227	16.60	33.70
7	4874.00	51.5 PK	74.0	-22.5	1.02 V	241	47.70	3.80
8	4874.00	37.4 AV	54.0	-16.6	1.02 V	241	33.60	3.80

**REMARKS:**

1. Emission Level(dBuV/m) = Raw Value(dBuV) + Correction Factor(dB/m)
2. Correction Factor(dB/m) = Antenna Factor(dB/m) + Cable Factor(dB)  
– Pre-Amplifier Factor(dB)
3. The other emission levels were very low against the limit.
4. Margin value = Emission Level – Limit value
5. “ \* ”: Fundamental frequency.



A D T

EUT TEST CONDITION		MEASUREMENT DETAIL	
CHANNEL	Channel 9	FREQUENCY RANGE	1 ~ 25GHz
INPUT POWER (SYSTEM)	120Vac, 60 Hz	DETECTOR FUNCTION	Peak (PK) Average (AV)
ENVIRONMENTAL CONDITIONS	25deg. C, 65%RH	TESTED BY	Ted Chang

ANTENNA POLARITY & TEST DISTANCE: HORIZONTAL AT 3 M								
NO.	FREQ. (MHz)	EMISSION LEVEL (dBuV/m)	LIMIT (dBuV/m)	MARGIN (dB)	ANTENNA HEIGHT (m)	TABLE ANGLE (Degree)	RAW VALUE (dBuV)	CORRECTION FACTOR (dB/m)
1	*2452.00	98.2 PK			1.00 H	210	64.60	33.60
2	*2452.00	88.8 AV			1.00 H	210	55.20	33.60
3	2483.50	61.7 PK	74.0	-12.3	1.00 H	314	28.00	33.70
4	2483.50	48.3 AV	54.0	-5.7	1.00 H	314	14.60	33.70
5	4904.00	50.2 PK	74.0	-23.8	1.02 H	148	46.30	3.90
6	4904.00	34.4 AV	54.0	-19.6	1.02 H	148	30.50	3.90

ANTENNA POLARITY & TEST DISTANCE: VERTICAL AT 3 M								
NO.	FREQ. (MHz)	EMISSION LEVEL (dBuV/m)	LIMIT (dBuV/m)	MARGIN (dB)	ANTENNA HEIGHT (m)	TABLE ANGLE (Degree)	RAW VALUE (dBuV)	CORRECTION FACTOR (dB/m)
1	2288.00	60.6 PK	74.0	-13.4	1.00 V	149	27.40	33.20
2	2288.00	51.1 AV	54.0	-2.9	1.00 V	149	17.90	33.20
3	*2452.00	104.9 PK			1.00 V	154	71.30	33.60
4	*2452.00	94.8 AV			1.00 V	154	61.20	33.60
5	2483.50	71.2 PK	74.0	-2.8	1.00 V	202	37.50	33.70
6	2483.50	52.8 AV	54.0	-1.2	1.00 V	202	19.10	33.70
7	4904.00	51.4 PK	74.0	-22.6	1.02 V	125	47.50	3.90
8	4904.00	37.4 AV	54.0	-16.6	1.02 V	125	33.50	3.90

**REMARKS:**

1. Emission Level(dBuV/m) = Raw Value(dBuV) + Correction Factor(dB/m)
2. Correction Factor(dB/m) = Antenna Factor(dB/m) + Cable Factor(dB)  
– Pre-Amplifier Factor(dB)
3. The other emission levels were very low against the limit.
4. Margin value = Emission Level – Limit value
5. “ \* “: Fundamental frequency.



A D T

**BELOW 1GHz WORST-CASE DATA : 802.11n (20MHz)**

EUT TEST CONDITION		MEASUREMENT DETAIL	
CHANNEL	Channel 6	FREQUENCY RANGE	Below 1000MHz
INPUT POWER (SYSTEM)	120Vac, 60 Hz	DETECTOR FUNCTION	Quasi-Peak
ENVIRONMENTAL CONDITIONS	24deg. C, 66%RH	TESTED BY	Ted Chang
TEST MODE	A		

ANTENNA POLARITY & TEST DISTANCE: HORIZONTAL AT 3 M								
NO.	FREQ. (MHz)	EMISSION LEVEL (dBuV/m)	LIMIT (dBuV/m)	MARGIN (dB)	ANTENNA HEIGHT (m)	TABLE ANGLE (Degree)	RAW VALUE (dBuV)	CORRECTION FACTOR (dB/m)
1	198.78	36.5 QP	43.5	-7.0	1.49 H	63	53.00	-16.50
2	266.68	39.3 QP	46.0	-6.7	1.49 H	309	52.80	-13.50
3	332.64	41.8 QP	46.0	-4.2	1.00 H	150	53.30	-11.50
4	534.40	38.7 QP	46.0	-7.3	1.49 H	36	46.40	-7.70
5	679.90	39.6 QP	46.0	-6.4	1.24 H	7	44.50	-4.90
6	734.22	36.7 QP	46.0	-9.3	1.49 H	84	40.80	-4.10
ANTENNA POLARITY & TEST DISTANCE: VERTICAL AT 3 M								
NO.	FREQ. (MHz)	EMISSION LEVEL (dBuV/m)	LIMIT (dBuV/m)	MARGIN (dB)	ANTENNA HEIGHT (m)	TABLE ANGLE (Degree)	RAW VALUE (dBuV)	CORRECTION FACTOR (dB/m)
1	198.78	39.5 QP	43.5	-4.0	1.50 V	48	56.00	-16.50
2	266.68	39.8 QP	46.0	-6.2	1.25 V	102	53.30	-13.50
3	332.64	40.3 QP	46.0	-5.7	1.25 V	44	51.80	-11.50
4	437.40	39.5 QP	46.0	-6.5	1.25 V	285	48.50	-9.00
5	534.40	34.8 QP	46.0	-11.2	1.50 V	153	42.50	-7.70
6	668.26	32.9 QP	46.0	-13.1	1.50 V	89	38.00	-5.10

**REMARKS:**

1. Emission Level(dBuV/m) = Raw Value(dBuV) + Correction Factor(dB/m)
2. Correction Factor(dB/m) = Antenna Factor(dB/m) + Cable Factor(dB) – Pre-Amplifier Factor (dB)
3. The other emission levels were very low against the limit.
4. Margin value = Emission Level – Limit value



A D T

EUT TEST CONDITION		MEASUREMENT DETAIL	
CHANNEL	Channel 6	FREQUENCY RANGE	Below 1000MHz
INPUT POWER (SYSTEM)	120Vac, 60 Hz	DETECTOR FUNCTION	Quasi-Peak
ENVIRONMENTAL CONDITIONS	24deg. C, 66%RH	TESTED BY	Cedric Wu
TEST MODE	B		

ANTENNA POLARITY & TEST DISTANCE: HORIZONTAL AT 3 M								
NO.	FREQ. (MHz)	EMISSION LEVEL (dBuV/m)	LIMIT (dBuV/m)	MARGIN (dB)	ANTENNA HEIGHT (m)	TABLE ANGLE (Degree)	RAW VALUE (dBuV)	CORRECTION FACTOR (dB/m)
1	198.78	34.9 QP	43.5	-8.6	1.01 H	79	51.40	-16.50
2	266.68	38.7 QP	46.0	-7.3	1.01 H	168	52.20	-13.50
3	625.58	43.8 QP	46.0	-2.2	1.25 H	222	49.50	-5.70
4	679.90	43.9 QP	46.0	-2.1	1.25 H	15	48.80	-4.90
5	749.74	44.3 QP	46.0	-1.7	1.01 H	114	47.90	-3.60
6	1000.00	47.8 QP	54.0	-6.2	1.25 H	262	47.10	0.70

ANTENNA POLARITY & TEST DISTANCE: VERTICAL AT 3 M								
NO.	FREQ. (MHz)	EMISSION LEVEL (dBuV/m)	LIMIT (dBuV/m)	MARGIN (dB)	ANTENNA HEIGHT (m)	TABLE ANGLE (Degree)	RAW VALUE (dBuV)	CORRECTION FACTOR (dB/m)
1	99.84	31.1 QP	43.5	-12.4	1.24 V	224	49.90	-18.80
2	198.78	31.5 QP	43.5	-12.0	1.00 V	27	48.00	-16.50
3	375.32	35.3 QP	46.0	-10.7	1.24 V	188	46.10	-10.80
4	499.48	38.3 QP	46.0	-7.7	1.00 V	23	46.40	-8.10
5	625.58	42.1 QP	46.0	-3.9	1.24 V	173	47.80	-5.70
6	749.74	42.7 QP	46.0	-3.3	1.99 V	190	46.30	-3.60

**REMARKS:**

1. Emission Level(dBuV/m) = Raw Value(dBuV) + Correction Factor(dB/m)
2. Correction Factor(dB/m) = Antenna Factor(dB/m) + Cable Factor(dB)
  - Pre-Amplifier Factor (dB)
3. The other emission levels were very low against the limit.
4. Margin value = Emission Level – Limit value



A D T

## 4.2 CONDUCTED EMISSION MEASUREMENT

### 4.2.1 LIMITS OF CONDUCTED EMISSION MEASUREMENT

FREQUENCY OF EMISSION (MHz)	CONDUCTED LIMIT (dB $\mu$ V)	
	Quasi-peak	Average
0.15 ~ 0.5	66 to 56	56 to 46
0.5 ~ 5	56	46
5 ~ 30	60	50

- NOTE:**
1. The lower limit shall apply at the transition frequencies.
  2. The limit decreases in line with the logarithm of the frequency in the range of 0.15 to 0.50MHz.
  3. All emanations from a class A/B digital device or system, including any network of conductors and apparatus connected thereto, shall not exceed the level of field strengths specified above.

### 4.2.2 TEST INSTRUMENTS

DESCRIPTION & MANUFACTURER	MODEL NO.	SERIAL NO.	DATE OF CALIBRATION	DUE DATE OF CALIBRATION
Test Receiver ROHDE & SCHWARZ	ESCS30	100288	Nov. 09, 2012	Nov. 08, 2013
RF signal cable Woken	5D-FB	Cable-HYCO2-01	Dec. 28, 2012	Dec. 27, 2013
LISN ROHDE & SCHWARZ (EUT)	ESH2-Z5	100100	Dec. 21, 2012	Dec. 20, 2013
LISN ROHDE & SCHWARZ (Peripheral)	ESH3-Z5	100311	Jul. 17, 2013	Jul. 16, 2014
Software ADT	BV ADT_Cond_ V7.3.7.3	NA	NA	NA

- NOTE:**
1. The calibration interval of the above test instruments is 12 months and the calibrations are traceable to NML/ROC and NIST/USA.
  2. The test was performed in HwaYa Shielded Room 2.
  3. The VCCI Site Registration No. is C-2047.



#### 4.2.3 TEST PROCEDURES

- a. The EUT was placed 0.4 meters from the conducting wall of the shielded room with EUT being connected to the power mains through a line impedance stabilization network (LISN). Other support units were connected to the power mains through another LISN. The two LISNs provide 50 ohm/ 50uH of coupling impedance for the measuring instrument.
- b. Both lines of the power mains connected to the EUT were checked for maximum conducted interference.
- c. The frequency range from 150kHz to 30MHz was searched. Emission levels under (Limit - 20dB) was not recorded.

**NOTE:** All modes of operation were investigated and the worst-case emissions are reported.

#### 4.2.4 DEVIATION FROM TEST STANDARD

No deviation.

#### 4.2.5 TEST SETUP

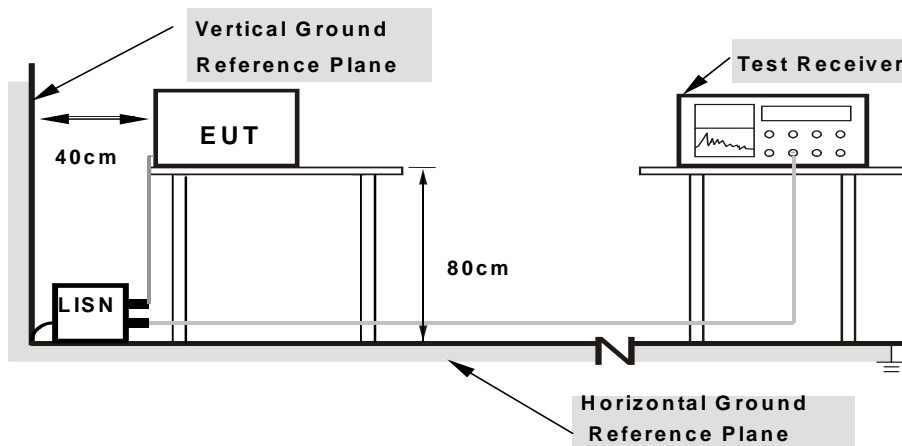

- Note:**
1. Support units were connected to second LISN.
  2. Both of LISNs (AMN) are 80 cm from EUT and at least 80 from other units and other metal planes

For the actual test configuration, please refer to the attached file (Test Setup Photo).

#### 4.2.6 EUT OPERATING CONDITIONS

Same as 4.1.6.

### 4.2.7 TEST RESULTS

#### CONDUCTED WORST-CASE DATA : 802.11n (20MHz)

<b>PHASE</b>	Line 1	<b>6dB BANDWIDTH</b>	9kHz
<b>TES MODE</b>	A		

No	Freq. [MHz]	Corr. Factor (dB)	Reading Value		Emission Level		Limit		Margin	
			[dB (uV)]		[dB (uV)]		[dB (uV)]		(dB)	
			Q.P.	AV.	Q.P.	AV.	Q.P.	AV.	Q.P.	AV.
1	0.15781	0.19	47.09	34.20	47.28	34.39	65.58	55.58	-18.30	-21.19
2	0.18906	0.20	40.94	28.80	41.14	29.00	64.08	54.08	-22.94	-25.08
3	0.36875	0.22	35.45	30.72	35.67	30.94	58.53	48.53	-22.86	-17.59
4	0.98594	0.29	26.43	23.53	26.72	23.82	56.00	46.00	-29.28	-22.18
5	6.30469	0.43	17.16	12.60	17.59	13.03	60.00	50.00	-42.41	-36.97
6	12.63281	0.55	14.21	9.18	14.76	9.73	60.00	50.00	-45.24	-40.27

- REMARKS:**
1. Q.P. and AV. are abbreviations of quasi-peak and average individually.
  2. The emission levels of other frequencies were very low against the limit.
  3. Margin value = Emission level - Limit value
  4. Correction factor = Insertion loss + Cable loss
  5. Emission Level = Correction Factor + Reading Value.

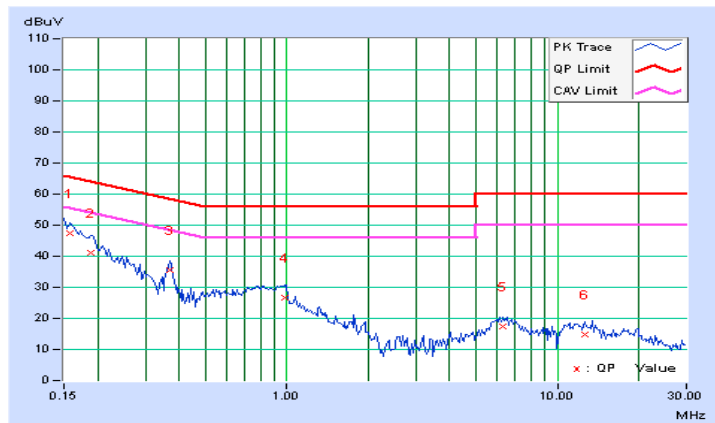



A D T

PHASE	Line 2	6dB BANDWIDTH	9kHz
TES MODE	A		

No	Freq. [MHz]	Corr. Factor (dB)	Reading Value		Emission Level		Limit		Margin	
			[dB (uV)]		[dB (uV)]		[dB (uV)]		(dB)	
			Q.P.	AV.	Q.P.	AV.	Q.P.	AV.	Q.P.	AV.
1	0.15051	0.19	49.56	35.53	49.75	35.72	65.97	55.97	-16.22	-20.25
2	0.23594	0.20	36.36	22.77	36.56	22.97	62.24	52.24	-25.67	-29.26
3	0.37265	0.26	33.26	24.40	33.52	24.66	58.44	48.44	-24.92	-23.78
4	0.95078	0.26	25.15	20.54	25.41	20.80	56.00	46.00	-30.59	-25.20
5	6.03125	0.49	20.62	15.70	21.11	16.19	60.00	50.00	-38.89	-33.81
6	11.37500	0.60	17.03	13.20	17.63	13.80	60.00	50.00	-42.37	-36.20

- REMARKS:**
1. Q.P. and AV. are abbreviations of quasi-peak and average individually.
  2. The emission levels of other frequencies were very low against the limit.
  3. Margin value = Emission level - Limit value
  4. Correction factor = Insertion loss + Cable loss
  5. Emission Level = Correction Factor + Reading Value.

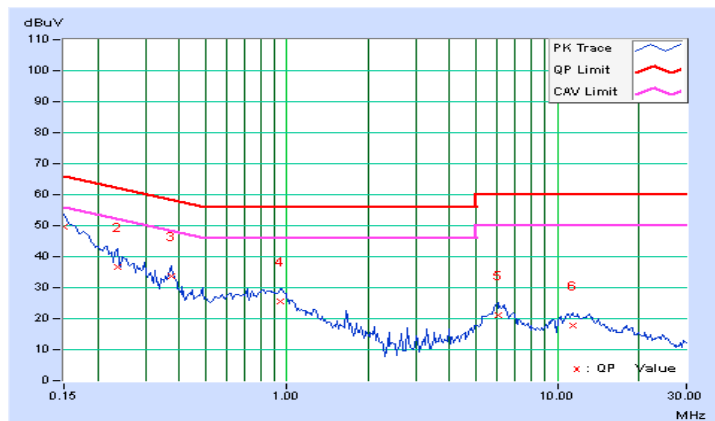



A D T

PHASE	Line 1	6dB BANDWIDTH	9kHz
TES MODE	B		

No	Freq. [MHz]	Corr. Factor (dB)	Reading Value		Emission Level		Limit		Margin	
			[dB (uV)]		[dB (uV)]		[dB (uV)]		(dB)	
			Q.P.	AV.	Q.P.	AV.	Q.P.	AV.	Q.P.	AV.
1	0.15000	0.19	57.47	43.74	57.66	43.93	66.00	56.00	-8.34	-12.07
2	0.17734	0.19	49.59	32.44	49.78	32.63	64.61	54.61	-14.83	-21.98
3	0.29494	0.21	43.68	37.61	43.89	37.82	60.38	50.38	-16.49	-12.56
4	0.88438	0.28	33.06	27.96	33.34	28.24	56.00	46.00	-22.66	-17.76
5	4.28906	0.40	34.91	29.62	35.31	30.02	56.00	46.00	-20.69	-15.98
6	12.06250	0.54	38.79	33.38	39.33	33.92	60.00	50.00	-20.67	-16.08

- REMARKS:**
1. Q.P. and AV. are abbreviations of quasi-peak and average individually.
  2. The emission levels of other frequencies were very low against the limit.
  3. Margin value = Emission level - Limit value
  4. Correction factor = Insertion loss + Cable loss
  5. Emission Level = Correction Factor + Reading Value.

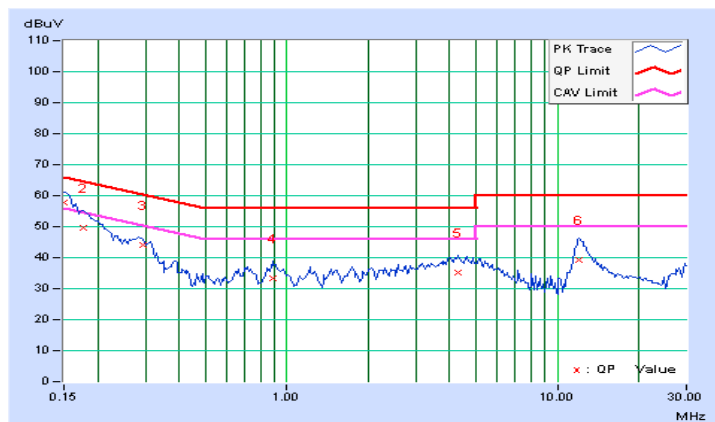



A D T

PHASE	Line 2	6dB BANDWIDTH	9kHz
TES MODE	B		

No	Freq. [MHz]	Corr. Factor (dB)	Reading Value		Emission Level		Limit		Margin	
			[dB (uV)]		[dB (uV)]		[dB (uV)]		(dB)	
			Q.P.	AV.	Q.P.	AV.	Q.P.	AV.	Q.P.	AV.
1	0.15000	0.19	56.41	43.44	56.60	43.63	66.00	56.00	-9.40	-12.37
2	0.18125	0.19	50.16	35.72	50.35	35.91	64.43	54.43	-14.08	-18.52
3	0.29063	0.23	42.69	34.93	42.92	35.16	60.51	50.51	-17.59	-15.35
4	0.88828	0.26	33.14	28.02	33.40	28.28	56.00	46.00	-22.60	-17.72
5	4.57422	0.46	33.58	28.39	34.04	28.85	56.00	46.00	-21.96	-17.15
6	12.62109	0.64	36.06	30.51	36.70	31.15	60.00	50.00	-23.30	-18.85

- REMARKS:**
1. Q.P. and AV. are abbreviations of quasi-peak and average individually.
  2. The emission levels of other frequencies were very low against the limit.
  3. Margin value = Emission level - Limit value
  4. Correction factor = Insertion loss + Cable loss
  5. Emission Level = Correction Factor + Reading Value.

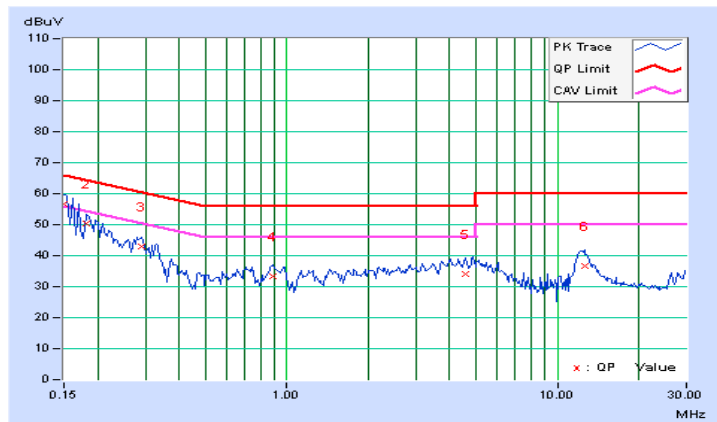

### 4.3 6dB BANDWIDTH MEASUREMENT

#### 4.3.1 LIMITS OF 6dB BANDWIDTH MEASUREMENT

The minimum of 6dB Bandwidth Measurement is 0.5 MHz.

#### 4.3.2 TEST SETUP

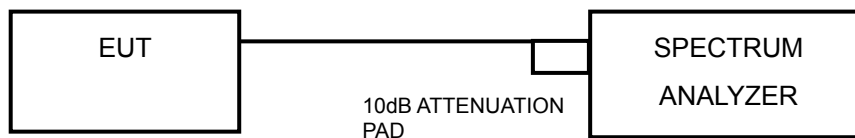

#### 4.3.3 TEST INSTRUMENTS

Refer to section 4.1.2 to get information of above instrument.

#### 4.3.4 TEST PROCEDURE

- a. Set resolution bandwidth (RBW) = 100kHz
- b. Set the video bandwidth (VBW)  $\geq 3 \times$  RBW, Detector = Peak.
- c. Trace mode = max hold.
- d. Sweep = auto couple.
- e. Measure the maximum width of the emission that is constrained by the frequencies associated with the two amplitude points (upper and lower) that are attenuated by 6 dB relative to the maximum level measured in the fundamental emission

#### 4.3.5 DEVIATION FROM TEST STANDARD

No deviation.

#### 4.3.6 EUT OPERATING CONDITIONS

The software provided by client to enable the EUT under transmission condition continuously at lowest, middle and highest channel frequencies individually.



### 4.3.7 TEST RESULTS

#### 802.11b

CHANNEL	FREQUENCY (MHz)	6dB BANDWIDTH (MHz)		MINIMUM LIMIT (MHz)	PASS / FAIL
		CHAIN 0	CHAIN 1		
1	2412	12.09	13.05	0.5	PASS
6	2437	12.11	12.13	0.5	PASS
11	2462	12.13	12.12	0.5	PASS

#### 802.11g

CHANNEL	FREQUENCY (MHz)	6dB BANDWIDTH (MHz)		MINIMUM LIMIT (MHz)	PASS / FAIL
		CHAIN 0	CHAIN 1		
1	2412	16.39	16.40	0.5	PASS
6	2437	16.41	16.43	0.5	PASS
11	2462	16.44	16.43	0.5	PASS



802.11n (20MHz)

CHANNEL	FREQUENCY (MHz)	6dB BANDWIDTH (MHz)		MINIMUM LIMIT (MHz)	PASS / FAIL
		CHAIN 0	CHAIN 1		
1	2412	17.64	17.65	0.5	PASS
6	2437	17.64	17.66	0.5	PASS
11	2462	17.66	17.64	0.5	PASS

802.11n (40MHz)

CHANNEL	FREQUENCY (MHz)	6dB BANDWIDTH (MHz)		MINIMUM LIMIT (MHz)	PASS / FAIL
		CHAIN 0	CHAIN 1		
3	2422	36.42	36.43	0.5	PASS
6	2437	36.43	36.41	0.5	PASS
9	2452	36.43	36.44	0.5	PASS



## 4.4 CONDUCTED OUTPUT POWER

### 4.4.1 LIMITS OF CONDUCTED OUTPUT POWER MEASUREMENT

For systems using digital modulation in the 2400–2483.5 MHz bands: 1 Watt (30dBm)

Per KDB 662911 D01 Multiple Transmitter Output v01r02 Method of conducted output power measurement on IEEE 802.11 devices,

Array Gain = 0 dB (i.e., no array gain) for  $NANT \leq 4$ ;

Array Gain = 0 dB (i.e., no array gain) for channel widths  $\geq 40$  MHz for any NANT;

Array Gain =  $5 \log(NANT/NSS)$  dB or 3 dB, whichever is less for 20-MHz channel widths with  $NANT \geq 5$ .

For power measurements on all other devices: Array Gain =  $10 \log(NANT/NSS)$  dB.

### 4.4.2 TEST SETUP

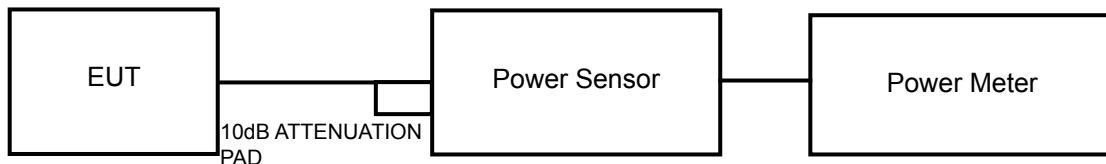

### 4.4.3 TEST INSTRUMENTS

Refer to section 4.1.2 to get information of above instrument.

### 4.4.4 TEST PROCEDURES

A peak / average power sensor was used on the output port of the EUT. A power meter was used to read the response of the peak / average power sensor. Record the peak power level.



A D T

#### 4.4.5 DEVIATION FROM TEST STANDARD

No deviation.

#### 4.4.6 EUT OPERATING CONDITIONS

Same as Item 4.3.6.



#### 4.4.7 TEST RESULTS

##### FOR PEAK POWER

###### 802.11b

CHAN.	FREQ. (MHz)	PEAK POWER (dBm)		TOTAL POWER (mW)	TOTAL POWER (dBm)	LIMIT (dBm)	PASS / FAIL
		CHAIN 0	CHAIN 1				
1	2412	23.44	20.99	346.403	25.40	30	PASS
6	2437	24.14	22.66	443.920	26.47	30	PASS
11	2462	24.14	22.84	451.727	26.55	30	PASS

###### 802.11g

CHAN.	FREQ. (MHz)	PEAK POWER (dBm)		TOTAL POWER (mW)	TOTAL POWER (dBm)	LIMIT (dBm)	PASS / FAIL
		CHAIN 0	CHAIN 1				
1	2412	25.56	22.91	555.183	27.44	30	PASS
6	2437	25.79	23.66	611.589	27.86	30	PASS
11	2462	25.38	24.69	639.586	28.06	30	PASS

###### 802.11n (20MHz)

CHAN.	FREQ. (MHz)	PEAK POWER (dBm)		TOTAL POWER (mW)	TOTAL POWER (dBm)	LIMIT (dBm)	PASS / FAIL
		CHAIN 0	CHAIN 1				
1	2412	25.18	22.99	528.677	27.23	30	PASS
6	2437	25.52	24.75	<b>654.989</b>	28.16	30	PASS
11	2462	25.16	24.48	608.638	27.84	30	PASS

###### 802.11n (40MHz)

CHAN.	FREQ. (MHz)	PEAK POWER (dBm)		TOTAL POWER (mW)	TOTAL POWER (dBm)	LIMIT (dBm)	PASS / FAIL
		CHAIN 0	CHAIN 1				
3	2422	22.98	20.93	322.489	25.09	30	PASS
6	2437	25.34	24.73	639.146	28.06	30	PASS
9	2452	24.76	24.09	555.674	27.45	30	PASS

**FOR AVERAGE POWER****802.11b**

CHAN.	FREQUENCY (MHz)	AVG. POWER (dBm)		TOTAL POWER (mW)	TOTAL POWER (dBm)
		CHAIN 0	CHAIN 1		
1	2412	21.08	18.67	201.854	23.05
6	2437	21.82	20.20	256.768	24.10
11	2462	21.91	20.50	267.441	24.27

**802.11g**

CHAN.	FREQUENCY (MHz)	AVG. POWER (dBm)		TOTAL POWER (mW)	TOTAL POWER (dBm)
		CHAIN 0	CHAIN 1		
1	2412	17.51	15.39	90.958	19.59
6	2437	17.72	16.07	99.614	19.98
11	2462	17.66	16.41	102.097	20.09

**802.11n (20MHz)**

CHAN.	FREQUENCY (MHz)	AVG. POWER (dBm)		TOTAL POWER (mW)	TOTAL POWER (dBm)
		CHAIN 0	CHAIN 1		
1	2412	17.48	15.34	90.174	19.55
6	2437	17.70	16.09	99.528	19.98
11	2462	17.66	16.35	101.497	20.06

**802.11n (40MHz)**

CHAN.	FREQUENCY (MHz)	AVG. POWER (dBm)		TOTAL POWER (mW)	TOTAL POWER (dBm)
		CHAIN 0	CHAIN 1		
3	2422	14.58	12.69	47.286	16.75
6	2437	17.41	15.79	93.012	19.69
9	2452	15.61	14.27	63.122	18.00

## 4.5 POWER SPECTRAL DENSITY MEASUREMENT

### 4.5.1 LIMITS OF POWER SPECTRAL DENSITY MEASUREMENT

The Maximum of Power Spectral Density Measurement is 8dBm.

### 4.5.2 TEST SETUP

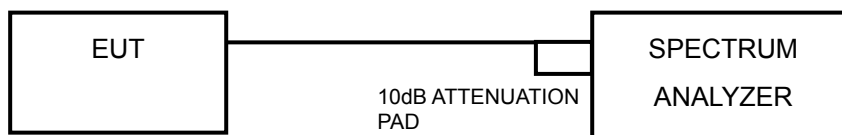

### 4.5.3 TEST INSTRUMENTS

Refer to section 4.1.2 to get information of above instrument.

### 4.5.4 TEST PROCEDURE

- Set the RBW = 3 kHz, VBW = 10 kHz, Detector = peak.
- Sweep time = auto couple, Trace mode = max hold, allow trace to fully stabilize.
- Use the peak marker function to determine the maximum power level in any 100 kHz band segment within the fundamental EBW.

### 4.5.5 DEVIATION FROM TEST STANDARD

No deviation.

### 4.5.6 EUT OPERATING CONDITION

Same as Item 4.3.6



### 4.5.7 TEST RESULTS

#### 802.11b

TX chain	Channel	Freq. (MHz)	PSD (dBm/3kHz)	10 log (N=2) dB	Total PSD (dBm/3kHz)	Limit (dBm/3kHz)	PASS /FAIL
0	1	2412	-3.58	3.01	-0.57	8	PASS
	6	2437	-2.95	3.01	0.06	8	PASS
	11	2462	-3.74	3.01	-0.73	8	PASS
1	1	2412	-6.07	3.01	-3.06	8	PASS
	6	2437	-3.40	3.01	-0.39	8	PASS
	11	2462	-4.44	3.01	-1.43	8	PASS

**NOTE:** Directional gain = 2dBi + 10log(2) = 5.01dBi < 6dBi, so the limit no need to reduced.

#### 802.11g

TX chain	Channel	Freq. (MHz)	PSD (dBm/3kHz)	10 log (N=2) dB	Total PSD (dBm/3kHz)	Limit (dBm/3kHz)	PASS /FAIL
0	1	2412	-8.60	3.01	-5.58	8	PASS
	6	2437	-7.88	3.01	-4.86	8	PASS
	11	2462	-7.27	3.01	-4.25	8	PASS
1	1	2412	-9.49	3.01	-6.47	8	PASS
	6	2437	-8.52	3.01	-5.50	8	PASS
	11	2462	-8.33	3.01	-5.31	8	PASS

**NOTE:** Directional gain = 2dBi + 10log(2) = 5.01dBi < 6dBi, so the limit no need to reduced.

#### 802.11n (20MHz)

TX chain	Channel	Freq. (MHz)	PSD (dBm/3kHz)	10 log (N=2) dB	Total PSD (dBm/3kHz)	Limit (dBm/3kHz)	PASS /FAIL
0	1	2412	-8.00	3.01	-4.97	8	PASS
	6	2437	-7.58	3.01	-4.55	8	PASS
	11	2462	-7.71	3.01	-4.68	8	PASS
1	1	2412	-9.27	3.01	-6.24	8	PASS
	6	2437	-8.33	3.01	-5.30	8	PASS
	11	2462	-9.08	3.01	-6.05	8	PASS

**NOTE:** Directional gain = 2dBi + 10log(2) = 5.01dBi < 6dBi, so the limit no need to reduced.



A D T

### 802.11n (40MHz)

TX chain	Channel	Freq. (MHz)	PSD (dBm/3kHz)	10 log (N=2) dB	Total PSD (dBm/3kHz)	Limit (dBm/3kHz)	PASS /FAIL
0	3	2422	-14.04	3.01	-10.99	8	PASS
	6	2437	-5.91	3.01	-2.86	8	PASS
	9	2452	-11.54	3.01	-8.49	8	PASS
1	3	2422	-14.98	3.01	-11.93	8	PASS
	6	2437	-12.42	3.01	-9.37	8	PASS
	9	2452	-13.93	3.01	-10.88	8	PASS

**NOTE:** Directional gain = 2dBi + 10log(2) = 5.01dBi < 6dBi, so the limit no need to reduced.

## 4.6 CONDUCTED OUT OF BAND EMISSION MEASUREMENT

### 4.6.1 LIMITS OF CONDUCTED OUT OF BAND EMISSION MEASUREMENT

Below -20dB of the highest emission level of operating band (in 100kHz Resolution Bandwidth).

### 4.6.2 TEST SETUP

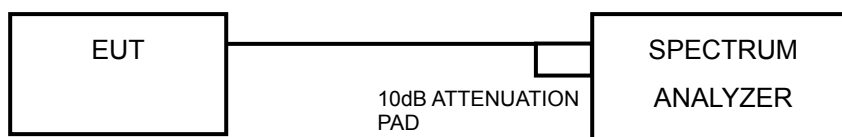

### 4.6.3 TEST INSTRUMENTS

Refer to section 4.1.2 to get information of above instrument.

### 4.6.4 TEST PROCEDURE

#### MEASUREMENT PROCEDURE REF

1. Set the RBW = 100 kHz.
2. Set the VBW  $\geq$  300 kHz.
3. Detector = peak.
4. Sweep time = auto couple.
5. Trace mode = max hold.
6. Allow trace to fully stabilize.
7. Use the peak marker function to determine the maximum power level in any 100 kHz band segment within the fundamental EBW.





A D T

## MEASUREMENT PROCEDURE OOB

1. Set RBW = 100 kHz.
2. Set VBW  $\geq$  300 kHz.
3. Ensure that the number of measurement points  $\geq$  span/RBW
4. According to measurement points to set differ measurement span.
5. Detector = peak.
6. Trace Mode = max hold.
7. Sweep = auto couple.

### 4.6.5 DEVIATION FROM TEST STANDARD

No deviation.

### 4.6.6 EUT OPERATING CONDITION

Same as Item 4.3.6

### 4.6.7 TEST RESULTS

The conducted emission test is performed on each TX port of operating mode without summing or adding  $10\log(N)$  since the limit is relative emission limit.

The spectrum plots are attached on the following pages. D1 line indicates the highest level, and D2 line indicates the 20dB offset below D1. It shows compliance with the requirement.



A D T

# 802.11b CHAIN 0

## CH 1

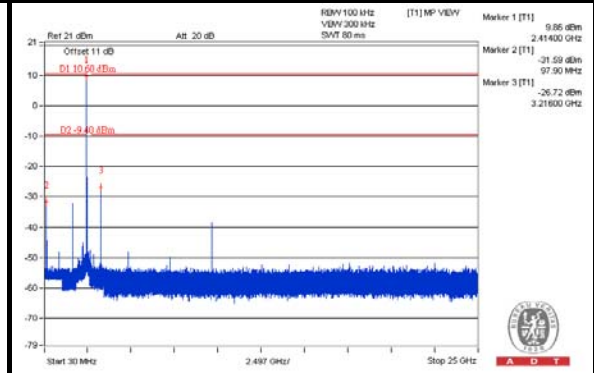
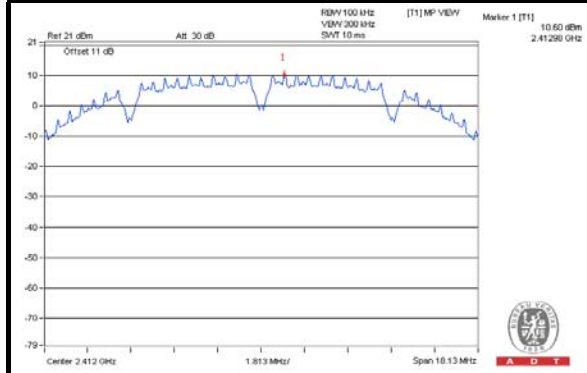

## CH 6

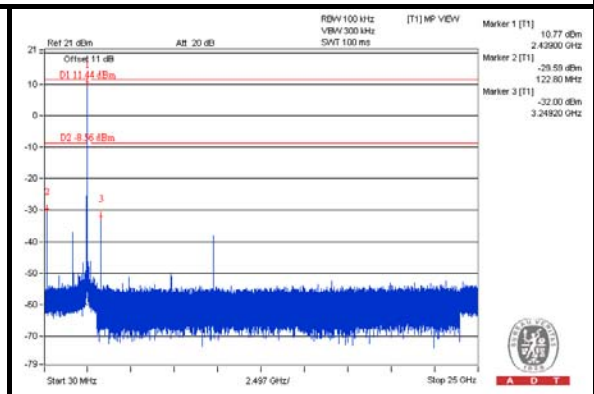
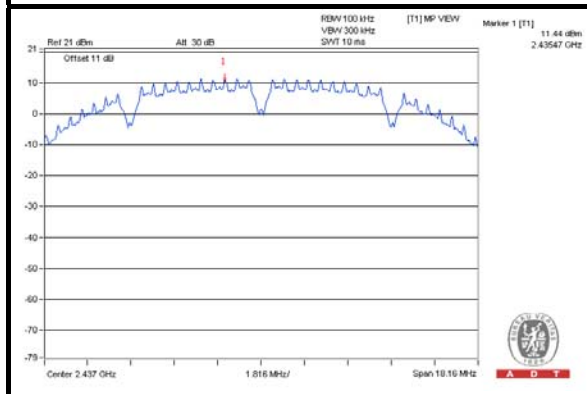

## CH 11

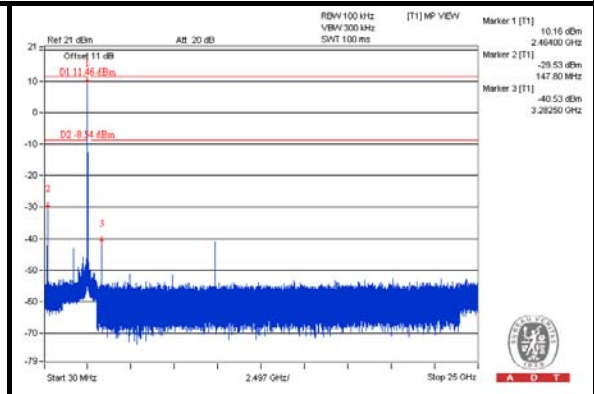
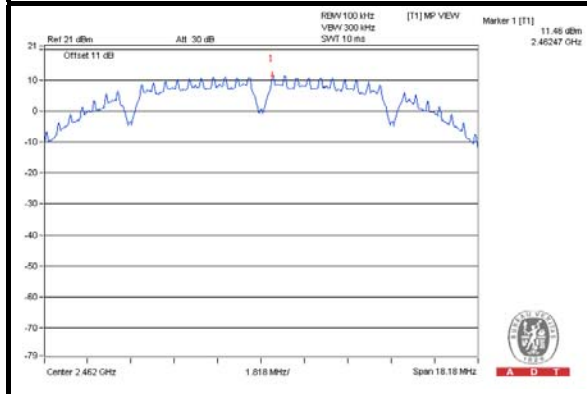

## CH 1 Band edge

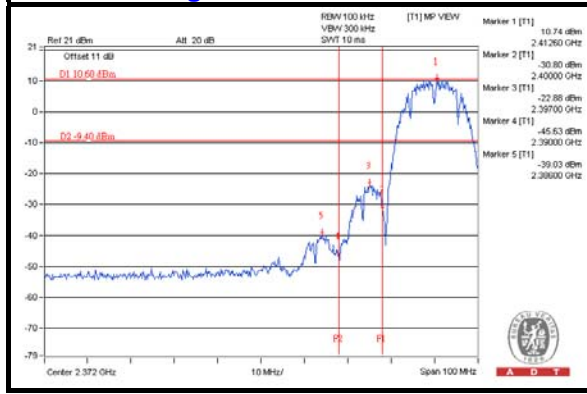

## CH 11 Band edge

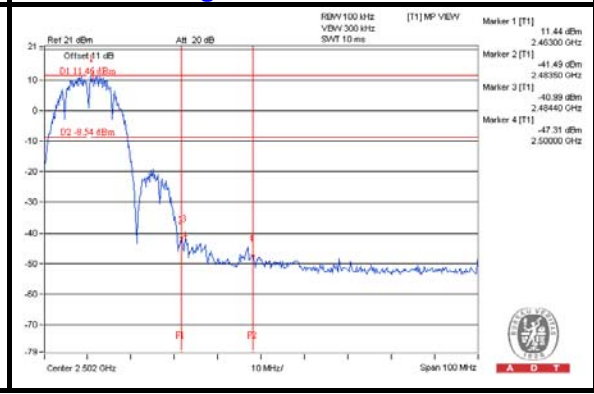



A D T

### CHAIN 1

#### CH 1

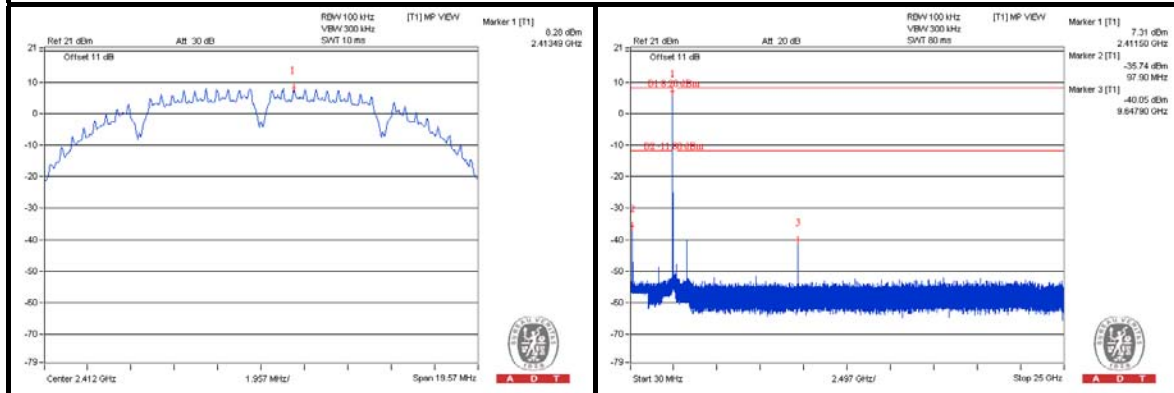

#### CH 6

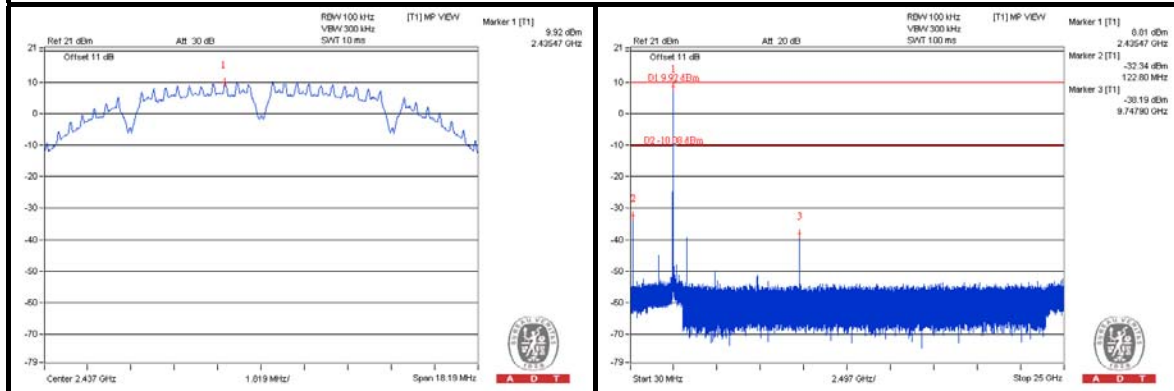

#### CH 11

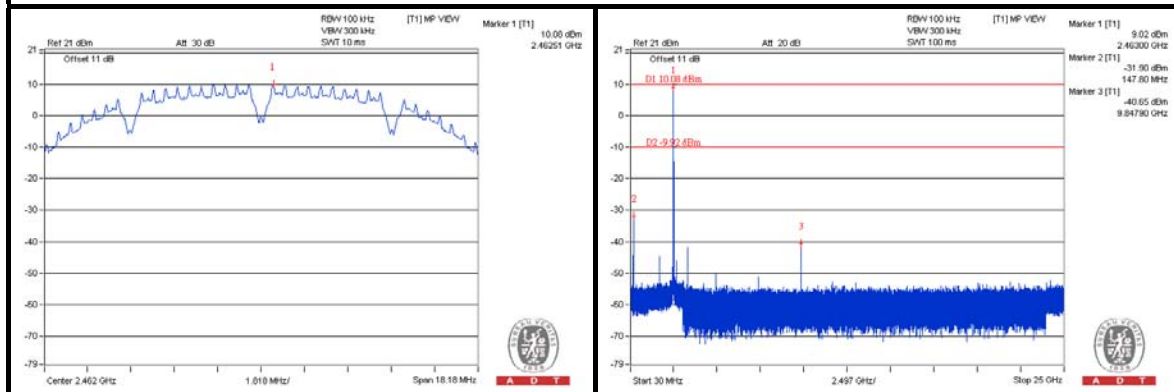

#### CH 1 Band edge

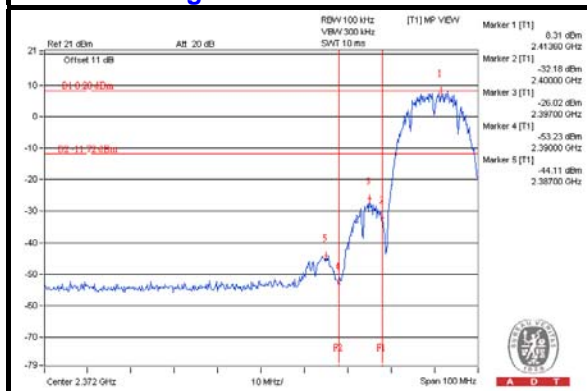

#### CH 11 Band edge

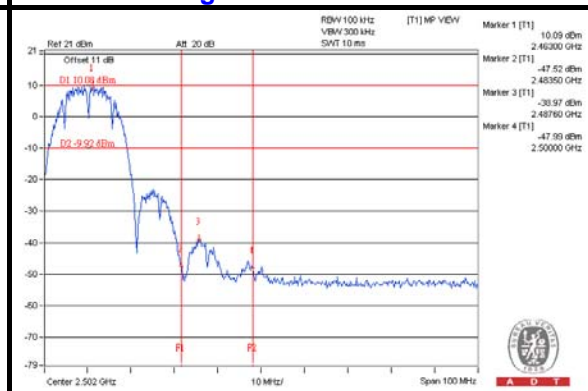



A D T

# 802.11g CHAIN 0

## CH 1

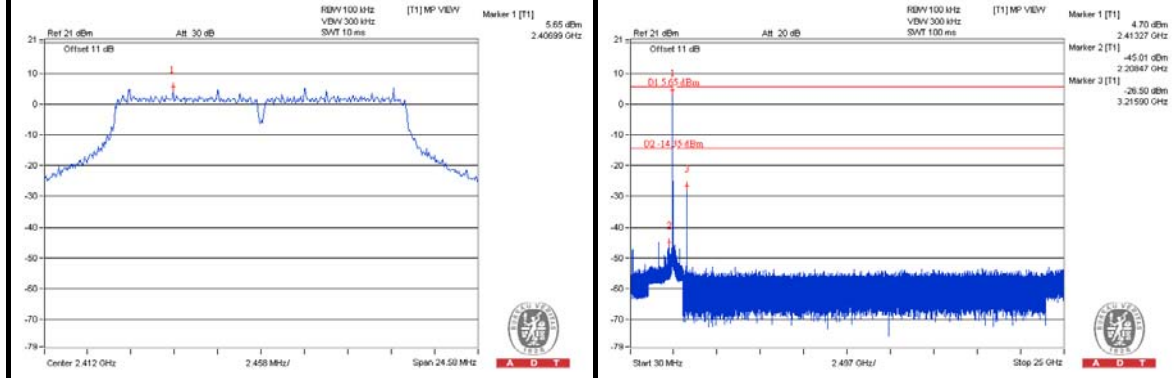

## CH 6

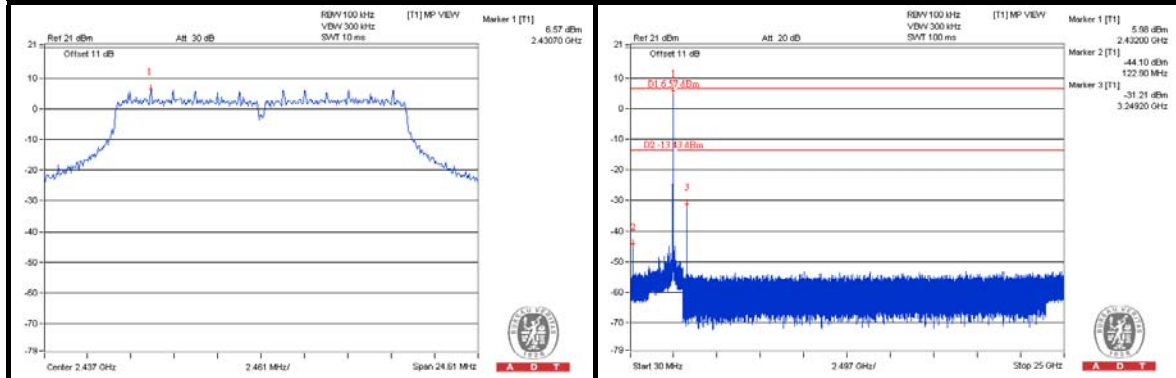

## CH 11

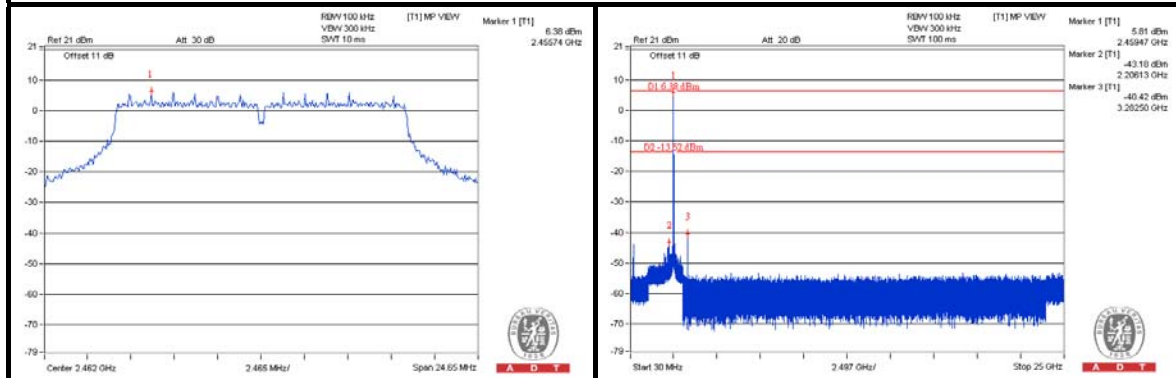

## CH 1 Band edge

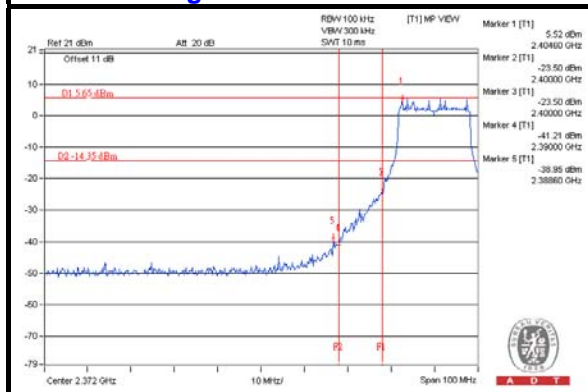

## CH 11 Band edge

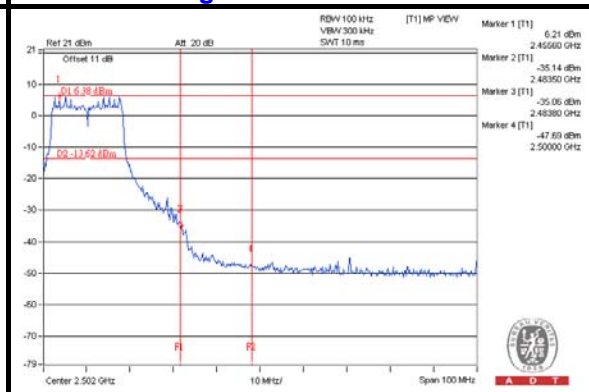



A D T

### CHAIN 1

#### CH 1

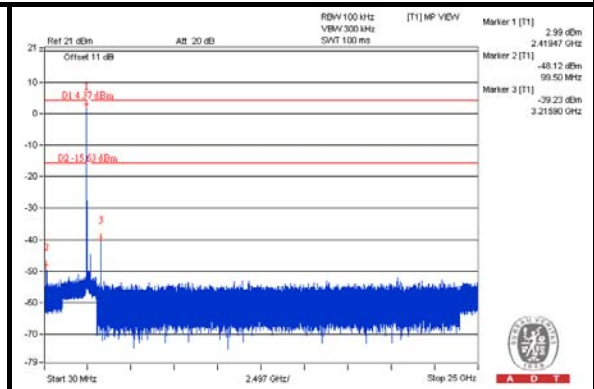
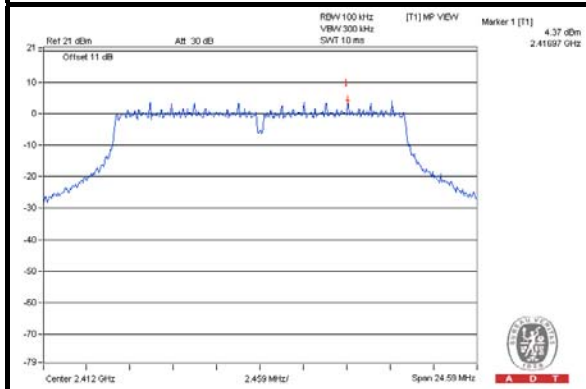

#### CH 6

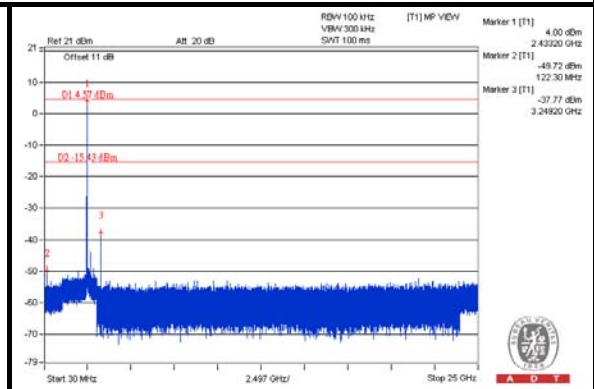
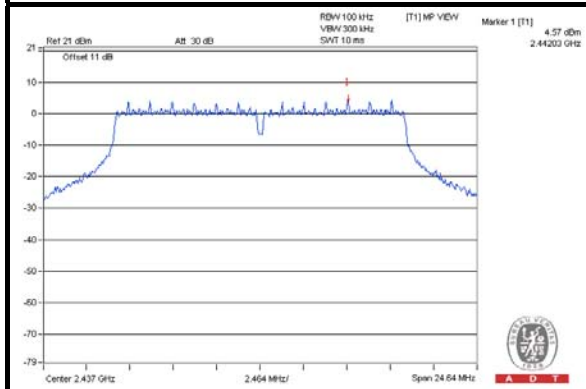

#### CH 11

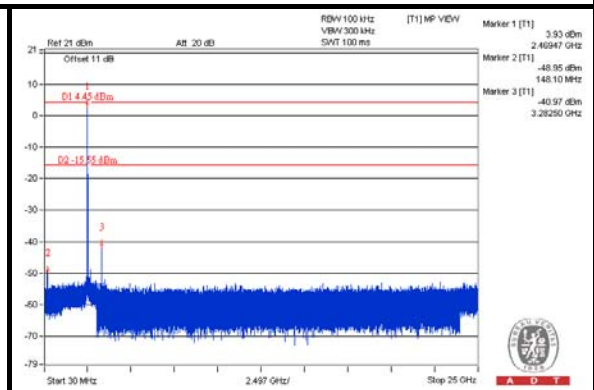
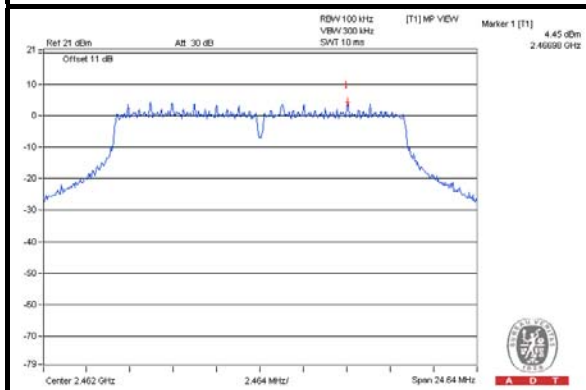

#### CH 1 Band edge

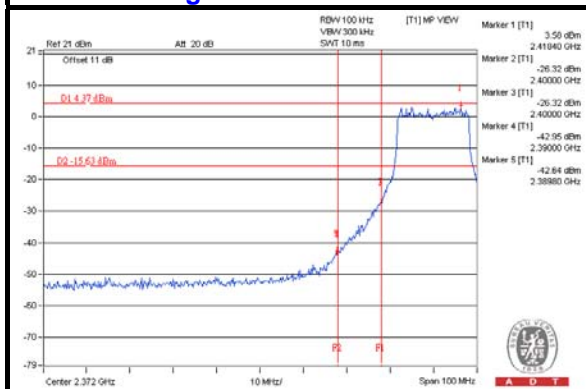

#### CH 11 Band edge

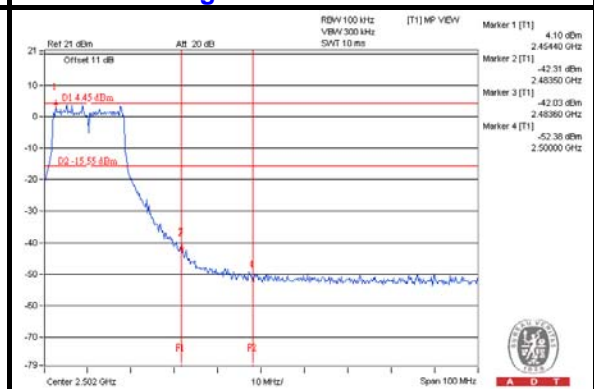



A D T

### 802.11n (20MHz)

### CHAIN 0

### CH 1

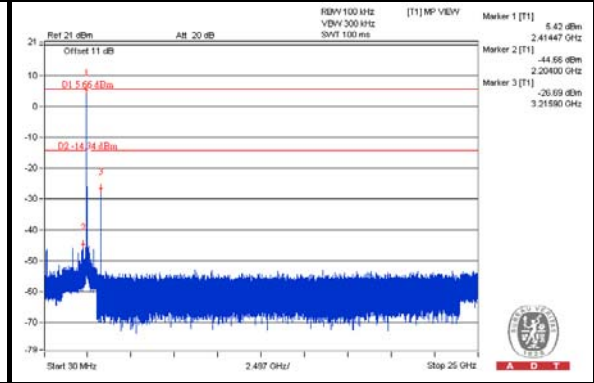
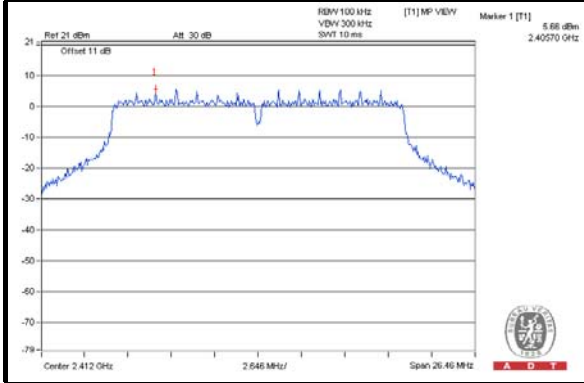

### CH 6

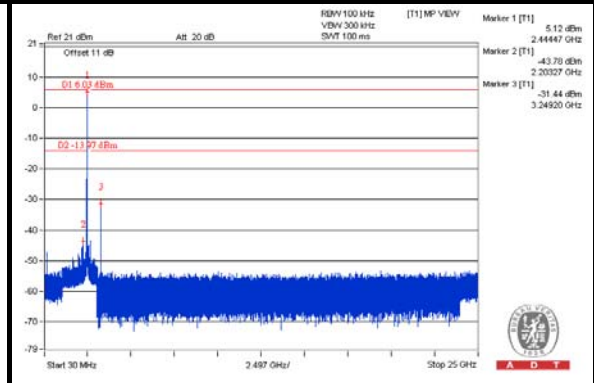
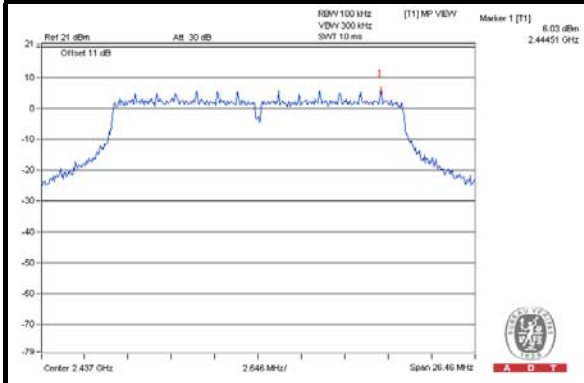

### CH 11

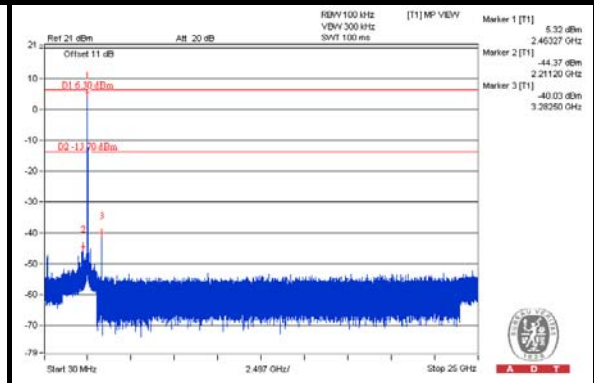
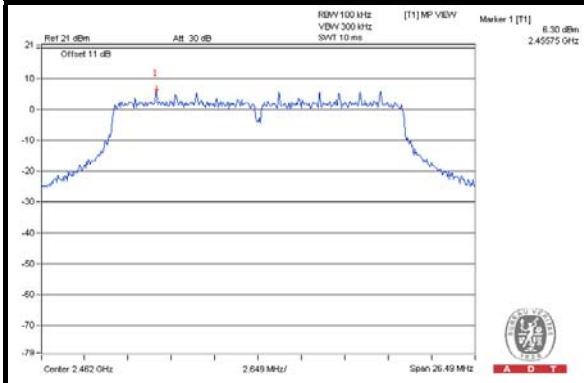

### CH 1 Band edge

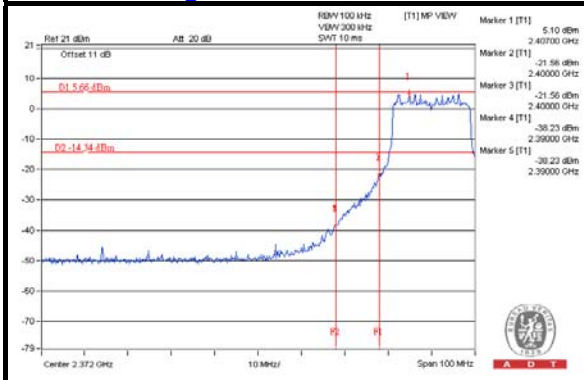

### CH 11 Band edge

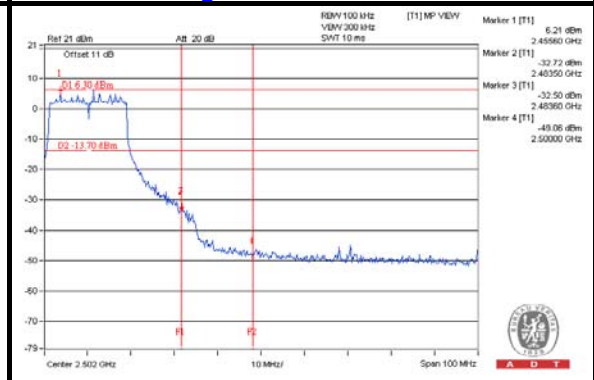



A D T

### CHAIN 1

#### CH 1

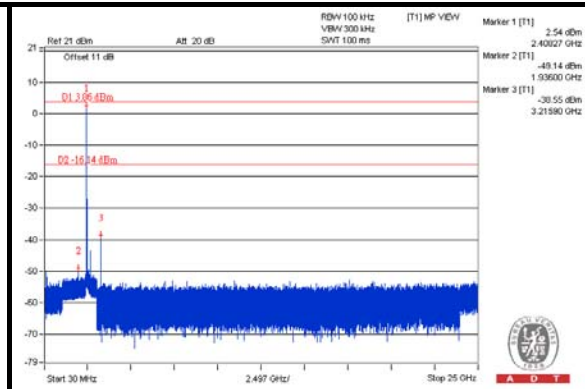
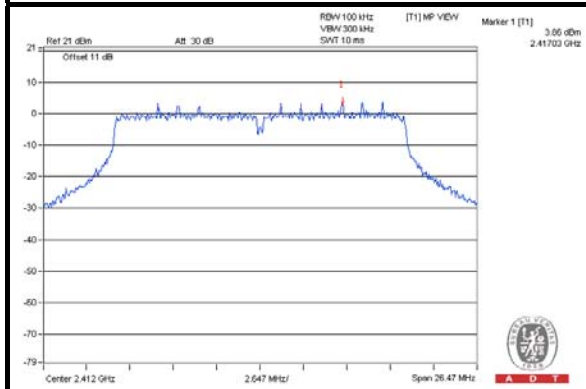

#### CH 6

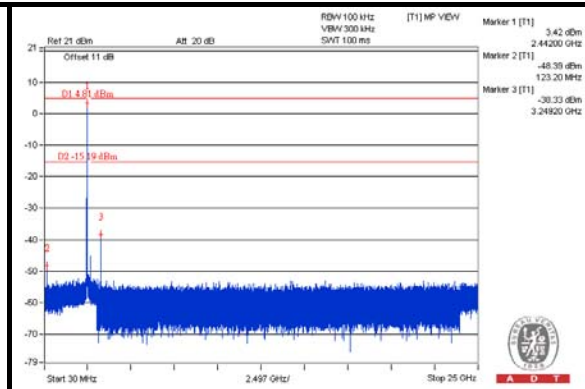
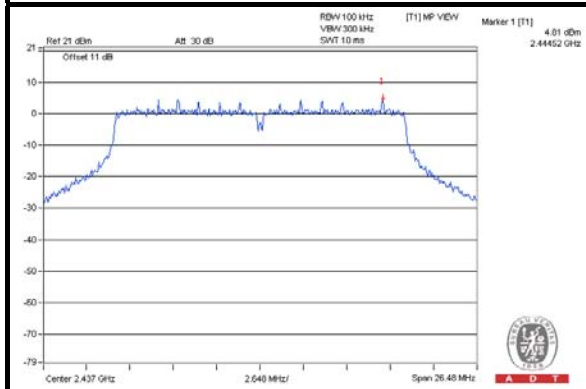

#### CH 11

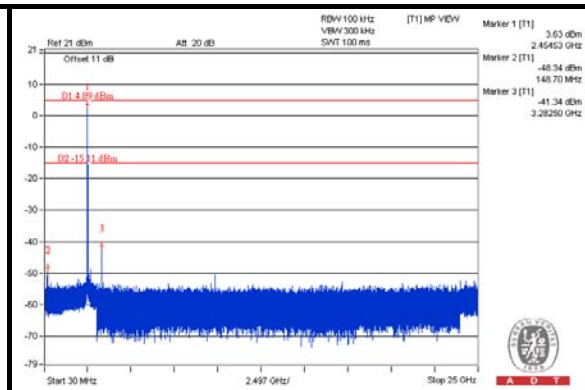
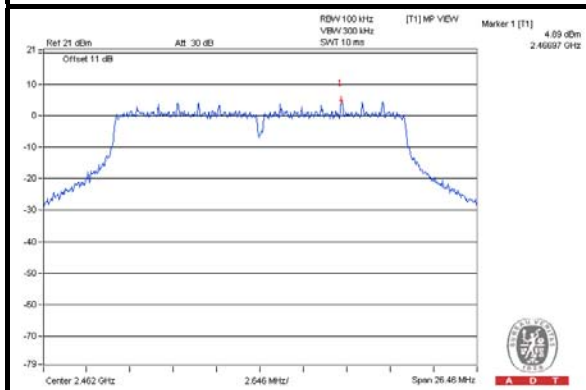

#### CH 1 Band edge

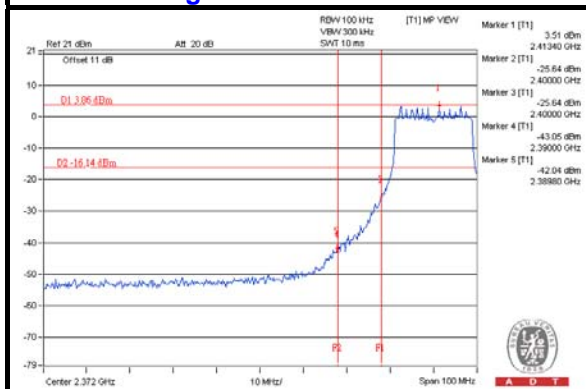

#### CH 11 Band edge

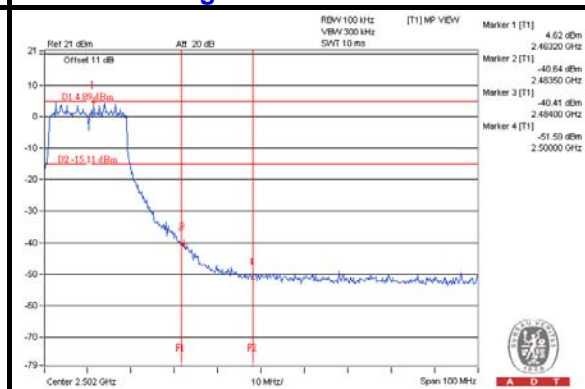



A D T

### 802.11n (40MHz)

### CHAIN 0

### CH 3

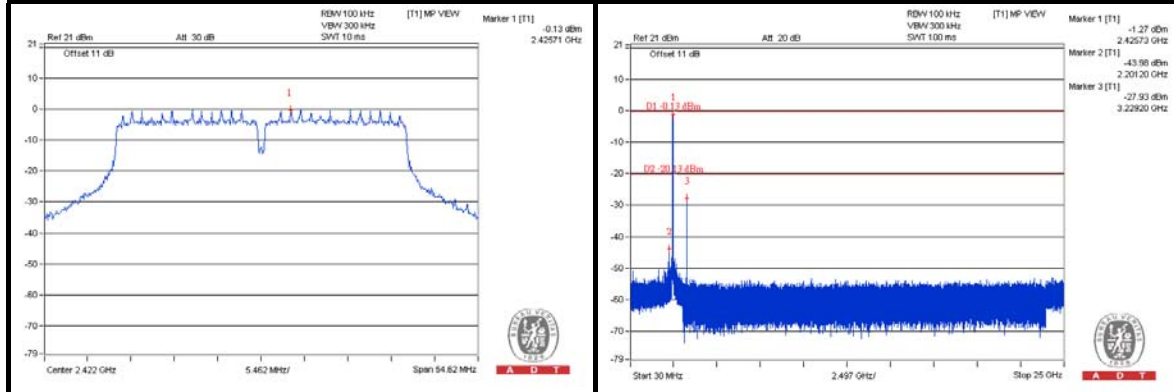

### CH 6

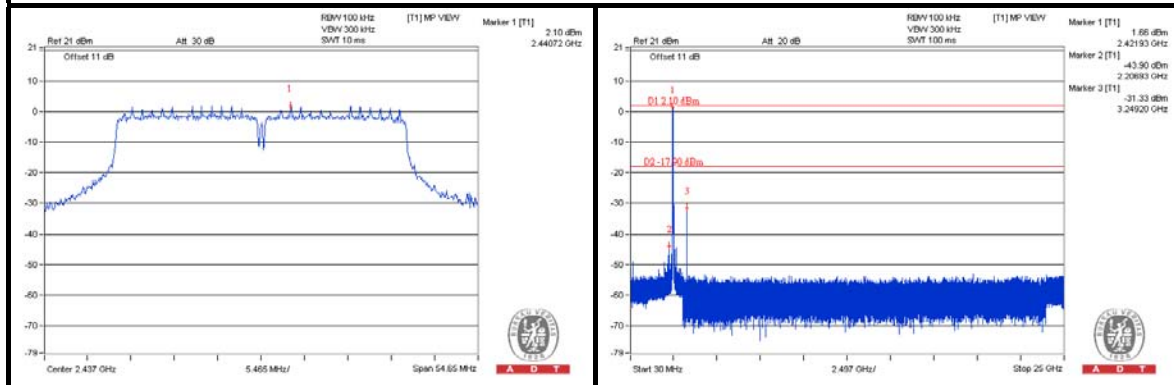

### CH 9

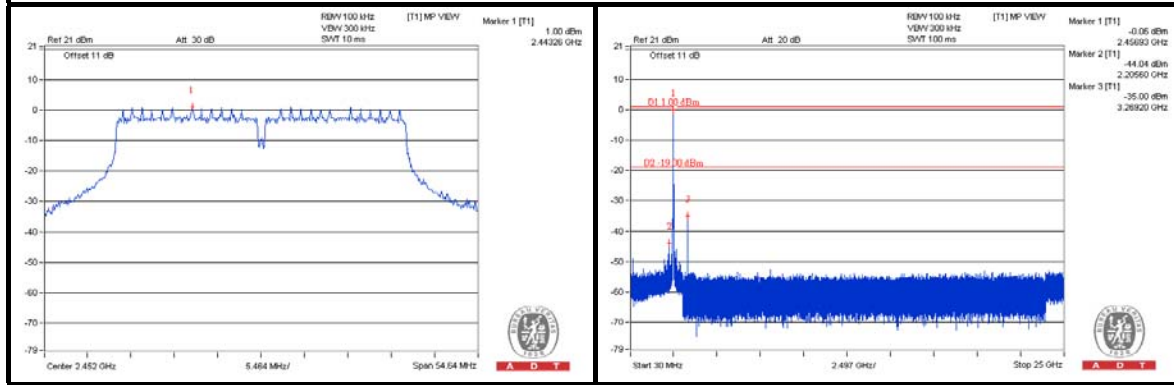

### CH 3 Band edge

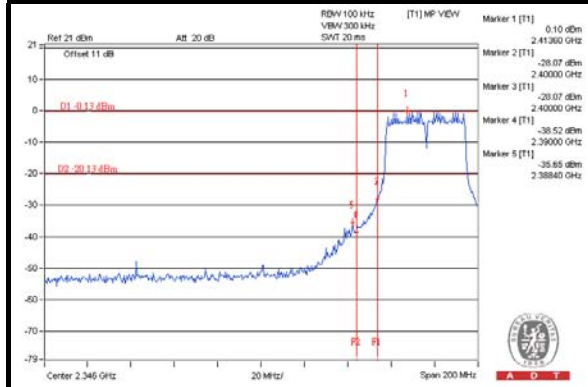

### CH 9 Band edge

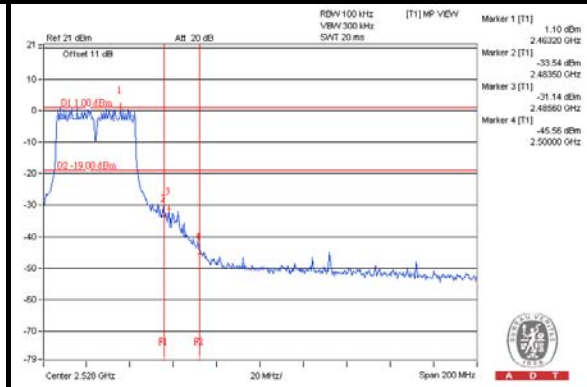



CHAIN 1

CH 3

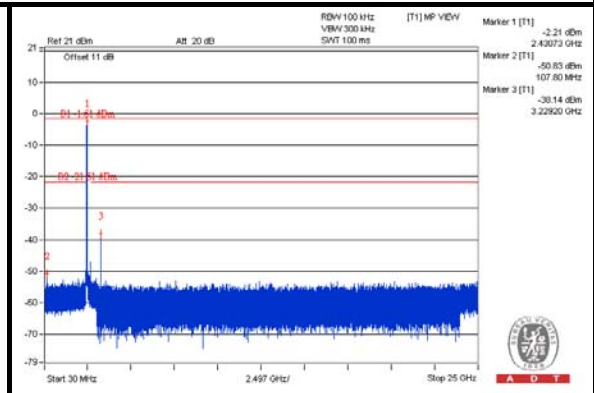
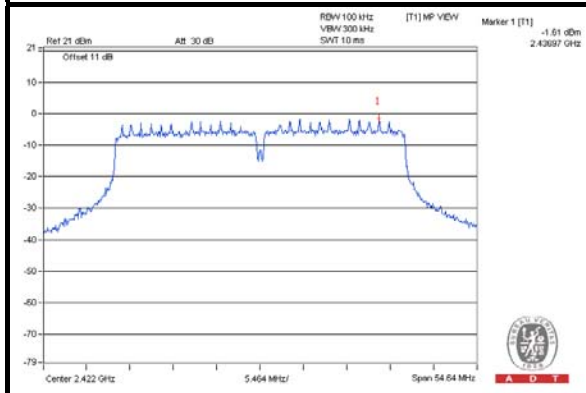

CH 6

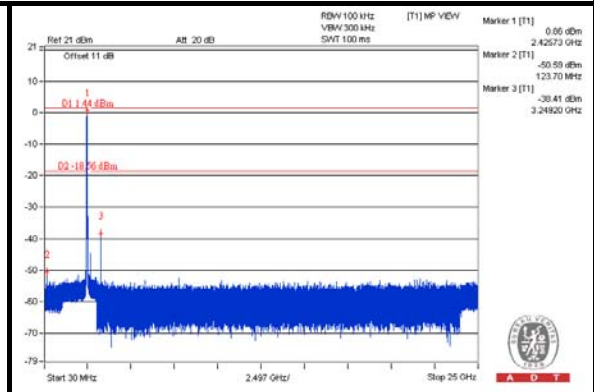
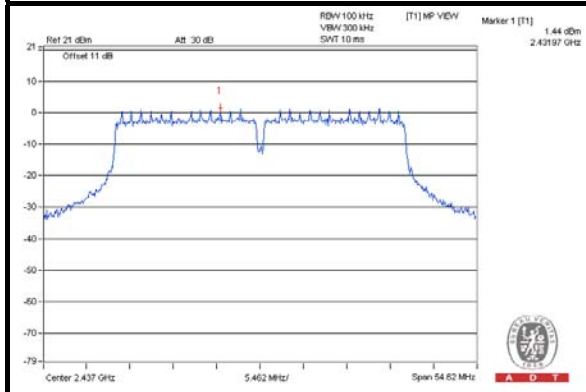

CH 9

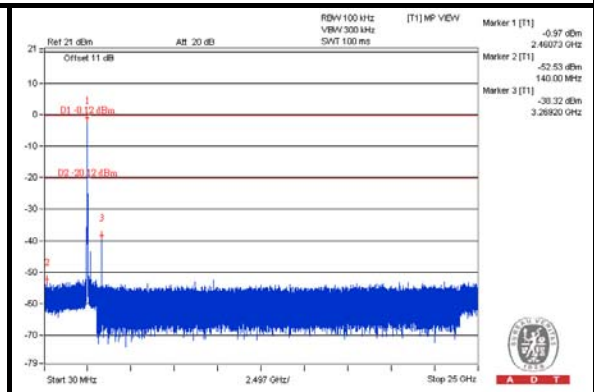
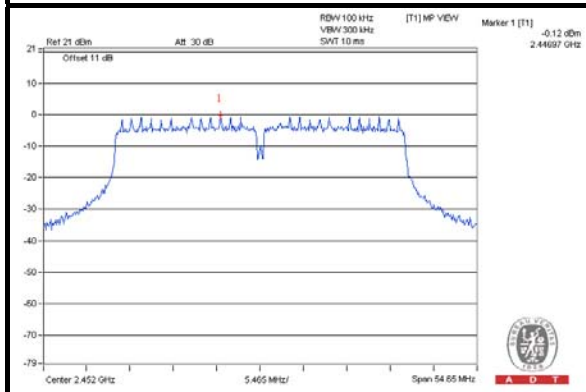

CH 3 Band edge

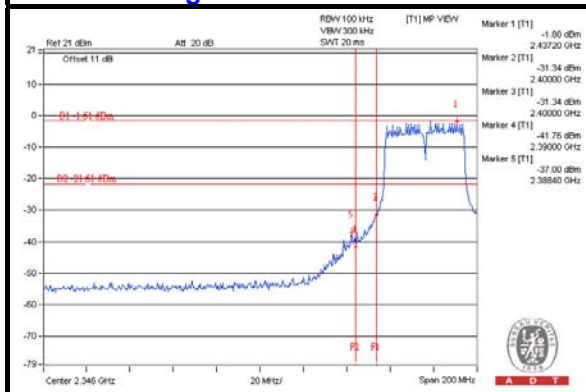

CH 9 Band edge

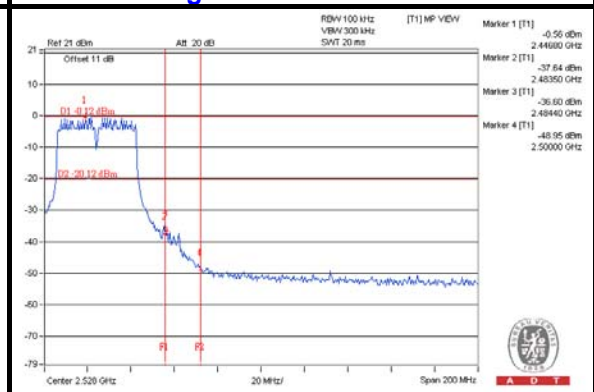



## 5. TEST TYPES AND RESULTS (FOR 5.0GHz BAND)

### 5.1 RADIATED EMISSION MEASUREMENT

#### 5.1.1 LIMITS OF RADIATED EMISSION MEASUREMENT

Radiated emissions which fall in the restricted bands must comply with the radiated emission limits specified as below table. Other emissions shall be at least 20dB below the highest level of the desired power:

FREQUENCIES (MHz)	FIELD STRENGTH (microvolts/meter)	MEASUREMENT DISTANCE (meters)
0.009 ~ 0.490	2400/F(kHz)	300
0.490 ~ 1.705	24000/F(kHz)	30
1.705 ~ 30.0	30	30
30 ~ 88	100	3
88 ~ 216	150	3
216 ~ 960	200	3
Above 960	500	3

**NOTE:**

1. The lower limit shall apply at the transition frequencies.
2. Emission level (dBuV/m) = 20 log Emission level (uV/m).
3. For frequencies above 1000MHz, the field strength limits are based on average detector, however, the peak field strength of any emission shall not exceed the maximum permitted average limits, specified above by more than 20dB under any condition of modulation.



A D T

#### 5.1.2 TEST INSTRUMENTS

Same as item 4.1.2.

#### 5.1.3 TEST PROCEDURES

Same as item 4.1.3.

#### 5.1.4 DEVIATION FROM TEST STANDARD

No deviation.

#### 5.1.5 TEST SETUP

Same as item 4.1.5.

#### 5.1.6 EUT OPERATING CONDITIONS

Same as item 4.1.6.



A D T

### 5.1.7 TEST RESULTS

#### ABOVE 1GHz DATA :

##### 802.11a

EUT TEST CONDITION		MEASUREMENT DETAIL	
CHANNEL	Channel 149	FREQUENCY RANGE	1 ~ 40GHz
INPUT POWER (SYSTEM)	120Vac, 60 Hz	DETECTOR FUNCTION	Peak (PK) Average (AV)
ENVIRONMENTAL CONDITIONS	25deg. C, 65%RH	TESTED BY	Ted Chang

ANTENNA POLARITY & TEST DISTANCE: HORIZONTAL AT 3 M								
NO.	FREQ. (MHz)	EMISSION LEVEL (dBuV/m)	LIMIT (dBuV/m)	MARGIN (dB)	ANTENNA HEIGHT (m)	TABLE ANGLE (Degree)	RAW VALUE (dBuV)	CORRECTION FACTOR (dB/m)
1	#5725.00	72.1 PK	85.2	-13.1	1.08 H	194	29.90	42.20
2	#5725.00	62.6 AV	75.7	-13.1	1.08 H	194	20.40	42.20
3	*5745.00	105.2 PK			1.00 H	339	63.00	42.20
4	*5745.00	95.7 AV			1.00 H	339	53.50	42.20
5	11490.00	57.9 PK	74.0	-16.1	1.25 H	247	44.60	13.30
6	11490.00	44.8 AV	54.0	-9.2	1.25 H	247	31.50	13.30

ANTENNA POLARITY & TEST DISTANCE: VERTICAL AT 3 M								
NO.	FREQ. (MHz)	EMISSION LEVEL (dBuV/m)	LIMIT (dBuV/m)	MARGIN (dB)	ANTENNA HEIGHT (m)	TABLE ANGLE (Degree)	RAW VALUE (dBuV)	CORRECTION FACTOR (dB/m)
1	#5725.00	79.9 PK	93.0	-13.1	1.08 V	194	37.70	42.20
2	#5725.00	69.7 AV	82.8	-13.1	1.08 V	194	27.50	42.20
3	*5745.00	113.0 PK			1.18 V	207	70.80	42.20
4	*5745.00	102.8 AV			1.18 V	207	60.60	42.20
5	11490.00	59.9 PK	74.0	-14.1	1.02 V	154	46.60	13.30
6	11490.00	46.8 AV	54.0	-7.2	1.02 V	154	33.50	13.30

#### REMARKS:

- Emission Level(dBuV/m) = Raw Value(dBuV) + Correction Factor(dB/m)
- Correction Factor(dB/m) = Antenna Factor(dB/m) + Cable Factor(dB) – Pre-Amplifier Factor(dB)
- The other emission levels were very low against the limit.
- Margin value = Emission Level – Limit value
- " \* ": Fundamental frequency.
- The limit value is defined as per 15.247.
- "#":The radiated frequency is out the restricted band.



A D T

EUT TEST CONDITION		MEASUREMENT DETAIL	
CHANNEL	Channel 157	FREQUENCY RANGE	1 ~ 40GHz
INPUT POWER (SYSTEM)	120Vac, 60 Hz	DETECTOR FUNCTION	Peak (PK) Average (AV)
ENVIRONMENTAL CONDITIONS	25deg. C, 65%RH	TESTED BY	Ted Chang

ANTENNA POLARITY & TEST DISTANCE: HORIZONTAL AT 3 M								
NO.	FREQ. (MHz)	EMISSION LEVEL (dBuV/m)	LIMIT (dBuV/m)	MARGIN (dB)	ANTENNA HEIGHT (m)	TABLE ANGLE (Degree)	RAW VALUE (dBuV)	CORRECTION FACTOR (dB/m)
1	*5785.00	104.4 PK			1.00 H	350	62.20	42.20
2	*5785.00	94.9 AV			1.00 H	350	52.70	42.20
3	11570.00	57.0 PK	74.0	-17.0	1.00 H	251	43.60	13.40
4	11570.00	44.5 AV	54.0	-9.5	1.00 H	251	31.10	13.40
ANTENNA POLARITY & TEST DISTANCE: VERTICAL AT 3 M								
NO.	FREQ. (MHz)	EMISSION LEVEL (dBuV/m)	LIMIT (dBuV/m)	MARGIN (dB)	ANTENNA HEIGHT (m)	TABLE ANGLE (Degree)	RAW VALUE (dBuV)	CORRECTION FACTOR (dB/m)
1	*5785.00	110.9 PK			1.00 V	139	68.70	42.20
2	*5785.00	100.7 AV			1.00 V	139	58.50	42.20
3	11570.00	60.0 PK	74.0	-14.0	1.53 V	169	46.60	13.40
4	11570.00	48.1 AV	54.0	-5.9	1.53 V	169	34.70	13.40

**REMARKS:**

1. Emission Level(dBuV/m) = Raw Value(dBuV) + Correction Factor(dB/m)
2. Correction Factor(dB/m) = Antenna Factor(dB/m) + Cable Factor(dB)  
– Pre-Amplifier Factor(dB)
3. The other emission levels were very low against the limit.
4. Margin value = Emission Level – Limit value
5. “ \* “: Fundamental frequency.
6. The limit value is defined as per 15.247.



A D T

EUT TEST CONDITION		MEASUREMENT DETAIL	
CHANNEL	Channel 165	FREQUENCY RANGE	1 ~ 40GHz
INPUT POWER (SYSTEM)	120Vac, 60 Hz	DETECTOR FUNCTION	Peak (PK) Average (AV)
ENVIRONMENTAL CONDITIONS	25deg. C, 65%RH	TESTED BY	Ted Chang

ANTENNA POLARITY & TEST DISTANCE: HORIZONTAL AT 3 M								
NO.	FREQ. (MHz)	EMISSION LEVEL (dBuV/m)	LIMIT (dBuV/m)	MARGIN (dB)	ANTENNA HEIGHT (m)	TABLE ANGLE (Degree)	RAW VALUE (dBuV)	CORRECTION FACTOR (dB/m)
1	*5825.00	104.1 PK			1.00 H	348	61.80	42.30
2	*5825.00	94.2 AV			1.00 H	348	51.90	42.30
3	#5850.00	61.0 PK	84.1	-23.1	1.03 H	181	18.70	42.30
4	#5850.00	51.0 AV	74.2	-23.2	1.03 H	181	8.70	42.30
5	11650.00	57.0 PK	74.0	-17.0	1.02 H	325	43.30	13.70
6	11650.00	44.7 AV	54.0	-9.3	1.02 H	325	31.00	13.70
ANTENNA POLARITY & TEST DISTANCE: VERTICAL AT 3 M								
NO.	FREQ. (MHz)	EMISSION LEVEL (dBuV/m)	LIMIT (dBuV/m)	MARGIN (dB)	ANTENNA HEIGHT (m)	TABLE ANGLE (Degree)	RAW VALUE (dBuV)	CORRECTION FACTOR (dB/m)
1	*5825.00	111.6 PK			1.05 V	189	69.30	42.30
2	*5825.00	101.7 AV			1.05 V	189	59.40	42.30
3	#5850.00	68.5 PK	91.6	-23.1	1.03 V	181	26.20	42.30
4	#5850.00	58.5 AV	81.7	-23.2	1.03 V	181	16.20	42.30
5	11650.00	61.2 PK	74.0	-12.8	1.02 V	325	47.50	13.70
6	11650.00	48.2 AV	54.0	-5.8	1.02 V	325	34.50	13.70

**REMARKS:**

1. Emission Level(dBuV/m) = Raw Value(dBuV) + Correction Factor(dB/m)
2. Correction Factor(dB/m) = Antenna Factor(dB/m) + Cable Factor(dB)  
– Pre-Amplifier Factor(dB)
3. The other emission levels were very low against the limit.
4. Margin value = Emission Level – Limit value
5. “ \* “: Fundamental frequency.
6. The limit value is defined as per 15.247.
7. “#”:The radiated frequency is out the restricted band.



A D T

802.11n (20MHz)

EUT TEST CONDITION		MEASUREMENT DETAIL	
CHANNEL	Channel 149	FREQUENCY RANGE	1 ~ 40GHz
INPUT POWER (SYSTEM)	120Vac, 60 Hz	DETECTOR FUNCTION	Peak (PK) Average (AV)
ENVIRONMENTAL CONDITIONS	25deg. C, 65%RH	TESTED BY	Ted Chang

ANTENNA POLARITY & TEST DISTANCE: HORIZONTAL AT 3 M								
NO.	FREQ. (MHz)	EMISSION LEVEL (dBuV/m)	LIMIT (dBuV/m)	MARGIN (dB)	ANTENNA HEIGHT (m)	TABLE ANGLE (Degree)	RAW VALUE (dBuV)	CORRECTION FACTOR (dB/m)
1	#5725.00	66.8 PK	82.4	-15.6	1.00 H	186	24.60	42.20
2	#5725.00	56.5 AV	72.1	-15.6	1.00 H	186	14.30	42.20
3	*5745.00	102.4 PK			1.00 H	353	60.20	42.20
4	*5745.00	92.1 AV			1.00 H	353	49.90	42.20
5	11490.00	59.5 PK	74.0	-14.5	1.03 H	205	46.20	13.30
6	11490.00	44.5 AV	54.0	-9.5	1.03 H	205	31.20	13.30

ANTENNA POLARITY & TEST DISTANCE: VERTICAL AT 3 M								
NO.	FREQ. (MHz)	EMISSION LEVEL (dBuV/m)	LIMIT (dBuV/m)	MARGIN (dB)	ANTENNA HEIGHT (m)	TABLE ANGLE (Degree)	RAW VALUE (dBuV)	CORRECTION FACTOR (dB/m)
1	#5725.00	75.8 PK	91.4	-15.6	1.00 V	186	33.60	42.20
2	#5725.00	66.2 AV	81.8	-15.6	1.00 V	186	24.00	42.20
3	*5745.00	111.4 PK			1.00 V	186	69.20	42.20
4	*5745.00	101.8 AV			1.00 V	186	59.60	42.20
5	11490.00	61.9 PK	74.0	-12.1	1.03 V	251	48.60	13.30
6	11490.00	46.8 AV	54.0	-7.2	1.03 V	251	33.50	13.30

REMARKS:

1. Emission Level(dBuV/m) = Raw Value(dBuV) + Correction Factor(dB/m)
2. Correction Factor(dB/m) = Antenna Factor(dB/m) + Cable Factor(dB) – Pre-Amplifier Factor(dB)
3. The other emission levels were very low against the limit.
4. Margin value = Emission Level – Limit value
5. “ \* “: Fundamental frequency.
6. The limit value is defined as per 15.247.
7. "#":The radiated frequency is out the restricted band.



A D T

EUT TEST CONDITION		MEASUREMENT DETAIL	
CHANNEL	Channel 157	FREQUENCY RANGE	1 ~ 40GHz
INPUT POWER (SYSTEM)	120Vac, 60 Hz	DETECTOR FUNCTION	Peak (PK) Average (AV)
ENVIRONMENTAL CONDITIONS	25deg. C, 65%RH	TESTED BY	Ted Chang

ANTENNA POLARITY & TEST DISTANCE: HORIZONTAL AT 3 M								
NO.	FREQ. (MHz)	EMISSION LEVEL (dBuV/m)	LIMIT (dBuV/m)	MARGIN (dB)	ANTENNA HEIGHT (m)	TABLE ANGLE (Degree)	RAW VALUE (dBuV)	CORRECTION FACTOR (dB/m)
1	*5785.00	104.6 PK			1.00 H	346	62.40	42.20
2	*5785.00	94.3 AV			1.00 H	346	52.10	42.20
3	11570.00	58.6 PK	74.0	-15.4	1.25 H	192	45.20	13.40
4	11570.00	44.6 AV	54.0	-9.4	1.25 H	192	31.20	13.40
ANTENNA POLARITY & TEST DISTANCE: VERTICAL AT 3 M								
NO.	FREQ. (MHz)	EMISSION LEVEL (dBuV/m)	LIMIT (dBuV/m)	MARGIN (dB)	ANTENNA HEIGHT (m)	TABLE ANGLE (Degree)	RAW VALUE (dBuV)	CORRECTION FACTOR (dB/m)
1	*5785.00	111.4 PK			1.00 V	184	69.20	42.20
2	*5785.00	101.7 AV			1.00 V	184	59.50	42.20
3	11570.00	61.0 PK	74.0	-13.0	1.02 V	126	47.60	13.40
4	11570.00	47.1 AV	54.0	-6.9	1.02 V	126	33.70	13.40

**REMARKS:**

1. Emission Level(dBuV/m) = Raw Value(dBuV) + Correction Factor(dB/m)
2. Correction Factor(dB/m) = Antenna Factor(dB/m) + Cable Factor(dB)  
– Pre-Amplifier Factor(dB)
3. The other emission levels were very low against the limit.
4. Margin value = Emission Level – Limit value
5. “ \* “: Fundamental frequency.
6. The limit value is defined as per 15.247.





A D T

EUT TEST CONDITION		MEASUREMENT DETAIL	
CHANNEL	Channel 165	FREQUENCY RANGE	1 ~ 40GHz
INPUT POWER (SYSTEM)	120Vac, 60 Hz	DETECTOR FUNCTION	Peak (PK) Average (AV)
ENVIRONMENTAL CONDITIONS	25deg. C, 65%RH	TESTED BY	Ted Chang

ANTENNA POLARITY & TEST DISTANCE: HORIZONTAL AT 3 M								
NO.	FREQ. (MHz)	EMISSION LEVEL (dBuV/m)	LIMIT (dBuV/m)	MARGIN (dB)	ANTENNA HEIGHT (m)	TABLE ANGLE (Degree)	RAW VALUE (dBuV)	CORRECTION FACTOR (dB/m)
1	*5825.00	104.0 PK			1.09 H	344	61.70	42.30
2	*5825.00	93.7 AV			1.09 H	344	51.40	42.30
3	#5850.00	65.9 PK	84.0	-18.1	1.33 H	189	23.60	42.30
4	#5850.00	55.6 AV	73.7	-18.1	1.33 H	189	13.30	42.30
5	11650.00	57.2 PK	74.0	-16.8	1.02 H	352	43.50	13.70
6	11650.00	44.9 AV	54.0	-9.1	1.02 H	352	31.20	13.70
ANTENNA POLARITY & TEST DISTANCE: VERTICAL AT 3 M								
NO.	FREQ. (MHz)	EMISSION LEVEL (dBuV/m)	LIMIT (dBuV/m)	MARGIN (dB)	ANTENNA HEIGHT (m)	TABLE ANGLE (Degree)	RAW VALUE (dBuV)	CORRECTION FACTOR (dB/m)
1	*5825.00	112.3 PK			1.08 V	187	70.00	42.30
2	*5825.00	101.5 AV			1.08 V	187	59.20	42.30
3	#5850.00	74.2 PK	92.3	-18.1	1.33 V	189	31.90	42.30
4	#5850.00	63.4 AV	81.5	-18.1	1.33 V	189	21.10	42.30
5	11650.00	60.3 PK	74.0	-13.7	1.35 V	357	46.60	13.70
6	11650.00	48.3 AV	54.0	-5.7	1.35 V	357	34.60	13.70

**REMARKS:**

1. Emission Level(dBuV/m) = Raw Value(dBuV) + Correction Factor(dB/m)
2. Correction Factor(dB/m) = Antenna Factor(dB/m) + Cable Factor(dB)  
– Pre-Amplifier Factor(dB)
3. The other emission levels were very low against the limit.
4. Margin value = Emission Level – Limit value
5. “ \* “: Fundamental frequency.
6. The limit value is defined as per 15.247.
7. “#”:The radiated frequency is out the restricted band.



A D T

802.11n (40MHz)

EUT TEST CONDITION		MEASUREMENT DETAIL	
CHANNEL	Channel 151	FREQUENCY RANGE	1 ~ 40GHz
INPUT POWER (SYSTEM)	120Vac, 60 Hz	DETECTOR FUNCTION	Peak (PK) Average (AV)
ENVIRONMENTAL CONDITIONS	25deg. C, 65%RH	TESTED BY	Ted Chang

ANTENNA POLARITY & TEST DISTANCE: HORIZONTAL AT 3 M								
NO.	FREQ. (MHz)	EMISSION LEVEL (dBuV/m)	LIMIT (dBuV/m)	MARGIN (dB)	ANTENNA HEIGHT (m)	TABLE ANGLE (Degree)	RAW VALUE (dBuV)	CORRECTION FACTOR (dB/m)
1	#5725.00	72.3 PK	81.1	-8.8	1.00 H	206	30.10	42.20
2	#5725.00	62.4 AV	71.2	-8.8	1.00 H	206	20.20	42.20
3	*5755.00	101.1 PK			1.00 H	340	58.90	42.20
4	*5755.00	91.2 AV			1.00 H	340	49.00	42.20
5	11510.00	57.9 PK	74.0	-16.1	1.41 H	230	44.60	13.30
6	11510.00	44.5 AV	54.0	-9.5	1.41 H	230	31.20	13.30

ANTENNA POLARITY & TEST DISTANCE: VERTICAL AT 3 M								
NO.	FREQ. (MHz)	EMISSION LEVEL (dBuV/m)	LIMIT (dBuV/m)	MARGIN (dB)	ANTENNA HEIGHT (m)	TABLE ANGLE (Degree)	RAW VALUE (dBuV)	CORRECTION FACTOR (dB/m)
1	#5725.00	81.3 PK	90.1	-8.8	1.00 V	206	39.10	42.20
2	#5725.00	71.8 AV	80.6	-8.8	1.00 V	206	29.60	42.20
3	*5755.00	110.1 PK			1.00 V	192	67.90	42.20
4	*5755.00	100.6 AV			1.00 V	192	58.40	42.20
5	11510.00	61.1 PK	74.0	-12.9	1.54 V	266	47.80	13.30
6	11510.00	46.9 AV	54.0	-7.1	1.54 V	266	33.60	13.30

REMARKS:

1. Emission Level(dBuV/m) = Raw Value(dBuV) + Correction Factor(dB/m)
2. Correction Factor(dB/m) = Antenna Factor(dB/m) + Cable Factor(dB) – Pre-Amplifier Factor(dB)
3. The other emission levels were very low against the limit.
4. Margin value = Emission Level – Limit value
5. “ \* “: Fundamental frequency.
6. The limit value is defined as per 15.247.
7. "#":The radiated frequency is out the restricted band.



A D T

EUT TEST CONDITION		MEASUREMENT DETAIL	
CHANNEL	Channel 159	FREQUENCY RANGE	1 ~ 40GHz
INPUT POWER (SYSTEM)	120Vac, 60 Hz	DETECTOR FUNCTION	Peak (PK) Average (AV)
ENVIRONMENTAL CONDITIONS	25deg. C, 65%RH	TESTED BY	Ted Chang

ANTENNA POLARITY & TEST DISTANCE: HORIZONTAL AT 3 M								
NO.	FREQ. (MHz)	EMISSION LEVEL (dBuV/m)	LIMIT (dBuV/m)	MARGIN (dB)	ANTENNA HEIGHT (m)	TABLE ANGLE (Degree)	RAW VALUE (dBuV)	CORRECTION FACTOR (dB/m)
1	*5795.00	101.3 PK			1.00 H	346	59.10	42.20
2	*5795.00	91.1 AV			1.00 H	346	48.90	42.20
3	#5850.00	56.9 PK	81.3	-24.4	1.00 H	195	14.60	42.30
4	#5850.00	46.7 AV	71.1	-24.4	1.00 H	195	4.40	42.30
5	11590.00	57.6 PK	74.0	-16.4	1.32 H	235	44.10	13.50
6	11590.00	45.1 AV	54.0	-8.9	1.32 H	235	31.60	13.50

ANTENNA POLARITY & TEST DISTANCE: VERTICAL AT 3 M								
NO.	FREQ. (MHz)	EMISSION LEVEL (dBuV/m)	LIMIT (dBuV/m)	MARGIN (dB)	ANTENNA HEIGHT (m)	TABLE ANGLE (Degree)	RAW VALUE (dBuV)	CORRECTION FACTOR (dB/m)
1	*5795.00	108.8 PK			1.09 V	206	66.60	42.20
2	*5795.00	98.6 AV			1.09 V	206	56.40	42.20
3	#5850.00	64.4 PK	88.8	-24.4	1.00 V	195	22.10	42.30
4	#5850.00	54.2 AV	78.6	-24.4	1.00 V	195	11.90	42.30
5	11590.00	60.1 PK	74.0	-13.9	1.02 V	321	46.60	13.50
6	11590.00	47.1 AV	54.0	-6.9	1.02 V	321	33.60	13.50

**REMARKS:**

1. Emission Level(dBuV/m) = Raw Value(dBuV) + Correction Factor(dB/m)
2. Correction Factor(dB/m) = Antenna Factor(dB/m) + Cable Factor(dB) – Pre-Amplifier Factor(dB)
3. The other emission levels were very low against the limit.
4. Margin value = Emission Level – Limit value
5. “ \* “: Fundamental frequency.
6. The limit value is defined as per 15.247.
7. “#”:The radiated frequency is out the restricted band.



A D T

**BELOW 1GHz WORST-CASE DATA : 802.11a**

EUT TEST CONDITION		MEASUREMENT DETAIL	
CHANNEL	Channel 149	FREQUENCY RANGE	Below 1000MHz
INPUT POWER (SYSTEM)	120Vac, 60 Hz	DETECTOR FUNCTION	Quasi-Peak
ENVIRONMENTAL CONDITIONS	25deg. C, 65%RH	TESTED BY	Ted Chang
TEST MODE	A		

ANTENNA POLARITY & TEST DISTANCE: HORIZONTAL AT 3 M								
NO.	FREQ. (MHz)	EMISSION LEVEL (dBuV/m)	LIMIT (dBuV/m)	MARGIN (dB)	ANTENNA HEIGHT (m)	TABLE ANGLE (Degree)	RAW VALUE (dBuV)	CORRECTION FACTOR (dB/m)
1	57.12	27.3 QP	40.0	-12.7	1.24 H	16	41.90	-14.60
2	374.04	35.8 QP	46.0	-10.2	1.00 H	155	46.60	-10.80
3	624.85	38.7 QP	46.0	-7.3	1.00 H	208	44.10	-5.40
4	751.23	42.3 QP	46.0	-3.7	1.00 H	4	45.40	-3.10
5	875.67	39.9 QP	46.0	-6.1	1.50 H	16	41.00	-1.10
6	1000.00	38.6 QP	54.0	-15.4	1.00 H	31	37.70	0.90
ANTENNA POLARITY & TEST DISTANCE: VERTICAL AT 3 M								
NO.	FREQ. (MHz)	EMISSION LEVEL (dBuV/m)	LIMIT (dBuV/m)	MARGIN (dB)	ANTENNA HEIGHT (m)	TABLE ANGLE (Degree)	RAW VALUE (dBuV)	CORRECTION FACTOR (dB/m)
1	51.29	34.6 QP	40.0	-5.4	1.00 V	318	48.60	-14.00
2	374.04	37.0 QP	46.0	-9.0	1.50 V	161	47.80	-10.80
3	500.42	36.3 QP	46.0	-9.7	1.00 V	8	44.60	-8.30
4	624.85	40.6 QP	46.0	-5.4	1.24 V	179	46.00	-5.40
5	751.23	37.3 QP	46.0	-8.7	1.00 V	168	40.40	-3.10
6	1000.00	40.4 QP	54.0	-13.6	1.50 V	8	39.50	0.90

**REMARKS:**

1. Emission Level(dBuV/m) = Raw Value(dBuV) + Correction Factor(dB/m)
2. Correction Factor(dB/m) = Antenna Factor(dB/m) + Cable Factor(dB) – Pre-Amplifier Factor (dB)
3. The other emission levels were very low against the limit.
4. Margin value = Emission Level – Limit value



A D T

EUT TEST CONDITION		MEASUREMENT DETAIL	
CHANNEL	Channel 149	FREQUENCY RANGE	Below 1000MHz
INPUT POWER (SYSTEM)	120Vac, 60 Hz	DETECTOR FUNCTION	Quasi-Peak
ENVIRONMENTAL CONDITIONS	24deg. C, 66%RH	TESTED BY	Cedric Wu
TEST MODE	B		

ANTENNA POLARITY & TEST DISTANCE: HORIZONTAL AT 3 M								
NO.	FREQ. (MHz)	EMISSION LEVEL (dBuV/m)	LIMIT (dBuV/m)	MARGIN (dB)	ANTENNA HEIGHT (m)	TABLE ANGLE (Degree)	RAW VALUE (dBuV)	CORRECTION FACTOR (dB/m)
1	198.78	35.4 QP	43.5	-8.1	1.25 H	73	51.90	-16.50
2	266.68	38.6 QP	46.0	-7.4	1.01 H	165	52.10	-13.50
3	625.58	43.6 QP	46.0	-2.4	1.25 H	209	49.30	-5.70
4	679.90	42.4 QP	46.0	-3.6	1.25 H	42	47.30	-4.90
5	749.74	43.8 QP	46.0	-2.2	1.50 H	102	47.40	-3.60
6	1000.00	47.5 QP	54.0	-6.5	1.25 H	267	46.80	0.70

ANTENNA POLARITY & TEST DISTANCE: VERTICAL AT 3 M								
NO.	FREQ. (MHz)	EMISSION LEVEL (dBuV/m)	LIMIT (dBuV/m)	MARGIN (dB)	ANTENNA HEIGHT (m)	TABLE ANGLE (Degree)	RAW VALUE (dBuV)	CORRECTION FACTOR (dB/m)
1	198.78	31.0 QP	43.5	-12.5	1.00 V	136	47.50	-16.50
2	375.32	35.6 QP	46.0	-10.4	1.24 V	192	46.40	-10.80
3	499.48	38.1 QP	46.0	-7.9	1.00 V	26	46.20	-8.10
4	625.58	41.3 QP	46.0	-4.7	1.24 V	180	47.00	-5.70
5	749.74	43.1 QP	46.0	-2.9	1.24 V	189	46.70	-3.60
6	1000.00	45.4 QP	54.0	-8.6	1.00 V	253	44.70	0.70

**REMARKS:**

1. Emission Level(dBuV/m) = Raw Value(dBuV) + Correction Factor(dB/m)
2. Correction Factor(dB/m) = Antenna Factor(dB/m) + Cable Factor(dB) – Pre-Amplifier Factor (dB)
3. The other emission levels were very low against the limit.
4. Margin value = Emission Level – Limit value



A D T

## 5.2 CONDUCTED EMISSION MEASUREMENT

### 5.2.1 LIMITS OF CONDUCTED EMISSION MEASUREMENT

FREQUENCY OF EMISSION (MHz)	CONDUCTED LIMIT (dB $\mu$ V)	
	Quasi-peak	Average
0.15 ~ 0.5	66 to 56	56 to 46
0.5 ~ 5	56	46
5 ~ 30	60	50

- NOTE:**
1. The lower limit shall apply at the transition frequencies.
  2. The limit decreases in line with the logarithm of the frequency in the range of 0.15 to 0.50MHz.
  3. All emanations from a class A/B digital device or system, including any network of conductors and apparatus connected thereto, shall not exceed the level of field strengths specified above.

### 5.2.2 TEST INSTRUMENTS

Same as item 4.2.2.

### 5.2.3 TEST PROCEDURES

Same as item 4.2.3.

### 5.2.4 DEVIATION FROM TEST STANDARD

No deviation.

### 5.2.5 TEST SETUP

Same as item 4.2.5.

### 5.2.6 EUT OPERATING CONDITIONS

Same as item 4.1.6.

### 5.2.7 TEST RESULTS

**CONDUCTED WORST-CASE DATA : 802.11a**

<b>PHASE</b>	Line 1	<b>6dB BANDWIDTH</b>	9kHz
<b>TEST MODE</b>	A		

No	Freq. [MHz]	Corr. Factor (dB)	Reading Value		Emission Level		Limit		Margin	
			[dB (uV)]		[dB (uV)]		[dB (uV)]		(dB)	
			Q.P.	AV.	Q.P.	AV.	Q.P.	AV.	Q.P.	AV.
1	0.15781	0.19	47.96	34.64	48.15	34.83	65.58	55.58	-17.43	-20.75
2	0.23984	0.20	35.48	23.53	35.68	23.73	62.10	52.10	-26.42	-28.37
3	0.37656	0.22	33.58	24.40	33.80	24.62	58.35	48.35	-24.56	-23.74
4	0.93906	0.28	24.05	20.48	24.33	20.76	56.00	46.00	-31.67	-25.24
5	6.40625	0.44	20.80	15.78	21.24	16.22	60.00	50.00	-38.76	-33.78
6	12.30859	0.55	17.56	13.96	18.11	14.51	60.00	50.00	-41.89	-35.49

**REMARKS:**

1. Q.P. and AV. are abbreviations of quasi-peak and average individually.
2. The emission levels of other frequencies were very low against the limit.
3. Margin value = Emission level - Limit value
4. Correction factor = Insertion loss + Cable loss
5. Emission Level = Correction Factor + Reading Value.

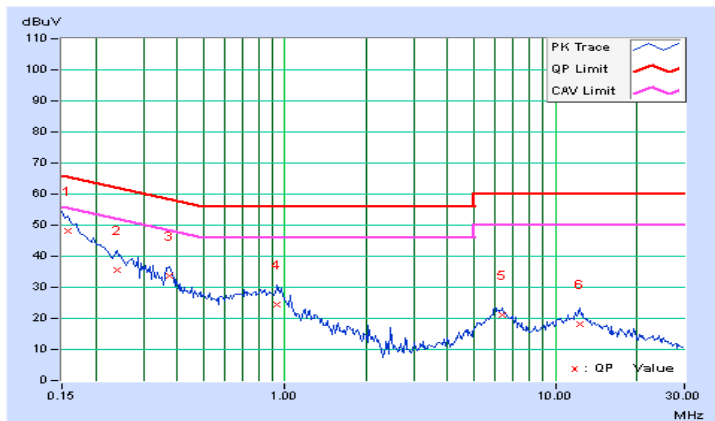



A D T

PHASE	Line 2	6dB BANDWIDTH	9kHz
TEST MODE	A		

No	Freq. [MHz]	Corr. Factor (dB)	Reading Value		Emission Level		Limit		Margin	
			[dB (uV)]		[dB (uV)]		[dB (uV)]		(dB)	
			Q.P.	AV.	Q.P.	AV.	Q.P.	AV.	Q.P.	AV.
1	0.16172	0.19	48.61	35.24	48.80	35.43	65.38	55.38	-16.57	-19.94
2	0.20469	0.19	41.30	29.29	41.49	29.48	63.42	53.42	-21.93	-23.94
3	0.37266	0.26	33.26	24.18	33.52	24.44	58.44	48.44	-24.92	-24.00
4	0.97422	0.26	24.59	21.61	24.85	21.87	56.00	46.00	-31.15	-24.13
5	6.06250	0.49	20.84	16.14	21.33	16.63	60.00	50.00	-38.67	-33.37
6	11.56641	0.61	17.40	13.61	18.01	14.22	60.00	50.00	-41.99	-35.78

**REMARKS:**

1. Q.P. and AV. are abbreviations of quasi-peak and average individually.
2. The emission levels of other frequencies were very low against the limit.
3. Margin value = Emission level - Limit value
4. Correction factor = Insertion loss + Cable loss
5. Emission Level = Correction Factor + Reading Value.

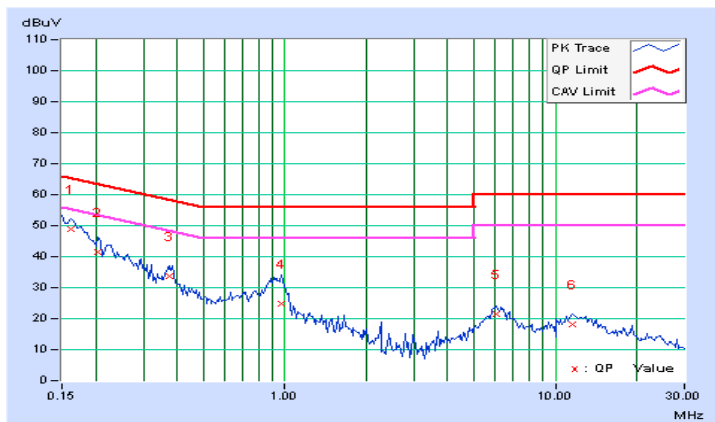



PHASE	Line 1	6dB BANDWIDTH	9kHz
TEST MODE	B		

No	Freq. [MHz]	Corr. Factor (dB)	Reading Value		Emission Level		Limit		Margin	
			[dB (uV)]		[dB (uV)]		[dB (uV)]		(dB)	
			Q.P.	AV.	Q.P.	AV.	Q.P.	AV.	Q.P.	AV.
1	0.15000	0.19	55.96	43.88	56.15	44.07	66.00	56.00	-9.85	-11.93
2	0.18788	0.20	48.62	36.21	48.82	36.41	64.13	54.13	-15.31	-17.72
3	0.29472	0.21	43.22	37.79	43.43	38.00	60.39	50.39	-16.96	-12.39
4	0.88438	0.28	33.17	28.04	33.45	28.32	56.00	46.00	-22.55	-17.68
5	4.77344	0.41	32.95	27.25	33.36	27.66	56.00	46.00	-22.64	-18.34
6	12.30859	0.55	36.94	31.42	37.49	31.97	60.00	50.00	-22.51	-18.03

**REMARKS:**

1. Q.P. and AV. are abbreviations of quasi-peak and average individually.
2. The emission levels of other frequencies were very low against the limit.
3. Margin value = Emission level - Limit value
4. Correction factor = Insertion loss + Cable loss
5. Emission Level = Correction Factor + Reading Value.

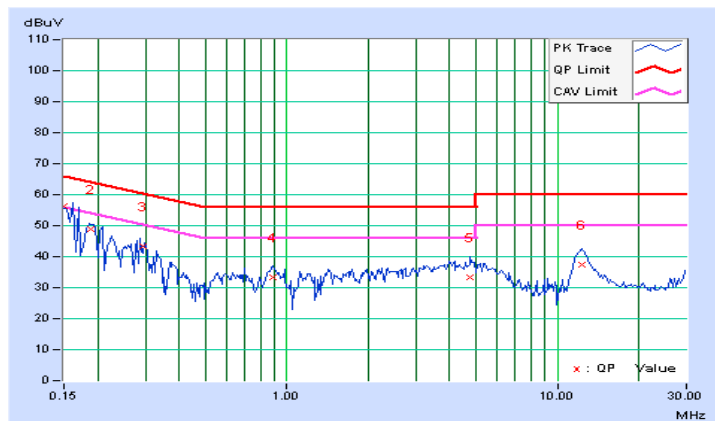



A D T

PHASE	Line 2	6dB BANDWIDTH	9kHz
TEST MODE	B		

No	Freq. [MHz]	Corr. Factor (dB)	Reading Value		Emission Level		Limit		Margin	
			[dB (uV)]		[dB (uV)]		[dB (uV)]		(dB)	
			Q.P.	AV.	Q.P.	AV.	Q.P.	AV.	Q.P.	AV.
1	0.15000	0.19	57.29	44.57	57.48	44.76	66.00	56.00	-8.52	-11.24
2	0.16562	0.19	52.44	33.67	52.63	33.86	65.18	55.18	-12.54	-21.31
3	0.29063	0.23	43.71	36.54	43.94	36.77	60.51	50.51	-16.57	-13.74
4	0.90000	0.26	33.78	27.78	34.04	28.04	56.00	46.00	-21.96	-17.96
5	4.00000	0.45	34.47	29.04	34.92	29.49	56.00	46.00	-21.08	-16.51
6	11.89063	0.62	38.62	33.25	39.24	33.87	60.00	50.00	-20.76	-16.13

**REMARKS:**

1. Q.P. and AV. are abbreviations of quasi-peak and average individually.
2. The emission levels of other frequencies were very low against the limit.
3. Margin value = Emission level - Limit value
4. Correction factor = Insertion loss + Cable loss
5. Emission Level = Correction Factor + Reading Value.

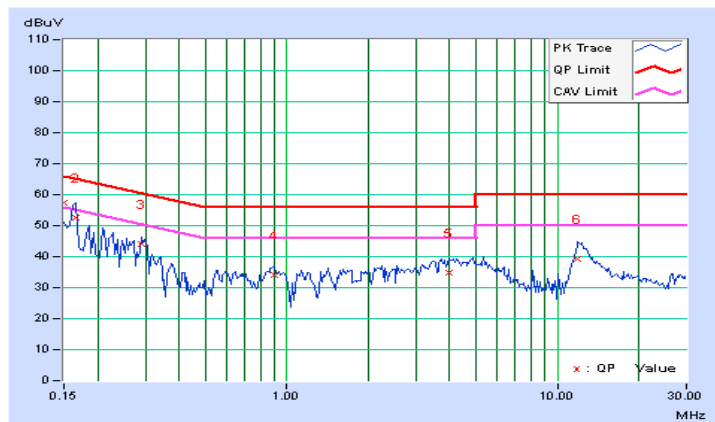



A D T

### **5.3 6dB BANDWIDTH MEASUREMENT**

#### **5.3.1 LIMITS OF 6dB BANDWIDTH MEASUREMENT**

The minimum of 6dB Bandwidth Measurement is 0.5MHz.

#### **5.3.2 TEST SETUP**

Same as item 4.3.2.

#### **5.3.3 TEST INSTRUMENTS**

Refer to section 4.1.2 to get information of above instrument.

#### **5.3.4 TEST PROCEDURE**

Same as item 4.3.4.

#### **5.3.5 DEVIATION FROM TEST STANDARD**

No deviation.

#### **5.3.6 EUT OPERATING CONDITIONS**

Same as item 4.3.6.



### 5.3.7 TEST RESULTS

#### 802.11a

CHANNEL	FREQUENCY (MHz)	6dB BANDWIDTH (MHz)		MINIMUM LIMIT (MHz)	PASS / FAIL
		CHAIN 0	CHAIN 1		
149	5745	16.39	16.37	0.5	PASS
157	5785	16.39	16.39	0.5	PASS
165	5825	16.38	16.40	0.5	PASS

#### 802.11n (20MHz)

CHANNEL	FREQUENCY (MHz)	6dB BANDWIDTH (MHz)		MINIMUM LIMIT (MHz)	PASS / FAIL
		CHAIN 0	CHAIN 1		
149	5745	17.59	17.61	0.5	PASS
157	5785	17.61	17.59	0.5	PASS
165	5825	17.64	17.65	0.5	PASS

#### 802.11n (40MHz)

CHANNEL	FREQUENCY (MHz)	6dB BANDWIDTH (MHz)		MINIMUM LIMIT (MHz)	PASS / FAIL
		CHAIN 0	CHAIN 1		
151	5755	36.36	36.35	0.5	PASS
159	5795	36.38	36.35	0.5	PASS

## 5.4 CONDUCTED OUTPUT POWER

### 5.4.1 LIMITS OF CONDUCTED OUTPUT POWER MEASUREMENT

For systems using digital modulation in the 5725 –5850 MHz bands: 1 Watt (30dBm)

Per KDB 662911 D01 Multiple Transmitter Output v01r02 Method of conducted output power measurement on IEEE 802.11 devices,

Array Gain = 0 dB (i.e., no array gain) for  $NANT \leq 4$ ;

Array Gain = 0 dB (i.e., no array gain) for channel widths  $\geq 40$  MHz for any NANT;

Array Gain =  $5 \log(NANT/NSS)$  dB or 3 dB, whichever is less for 20-MHz channel widths with  $NANT \geq 5$ .

For power measurements on all other devices: Array Gain =  $10 \log(NANT/NSS)$  dB.

### 5.4.2 TEST SETUP

Same as Item 4.4.2.

### 5.4.3 INSTRUMENTS

Refer to section 4.1.2 to get information of above instrument.

### 5.4.4 TEST PROCEDURES

Same as Item 4.4.4.

### 5.4.5 DEVIATION FROM TEST STANDARD

No deviation.

### 5.4.6 EUT OPERATING CONDITIONS

Same as Item 4.3.6.



A D T

## 5.4.7 TEST RESULTS

### FOR PEAK POWER

#### 802.11a

CHAN.	FREQ. (MHz)	PEAK POWER (dBm)		TOTAL POWER (mW)	TOTAL POWER (dBm)	LIMIT (dBm)	PASS / FAIL
		CHAIN 0	CHAIN 1				
149	5745	25.75	24.89	684.156	28.35	30	PASS
157	5785	25.44	24.48	630.488	28.00	30	PASS
165	5825	25.39	24.51	628.427	27.98	30	PASS

#### 802.11n (20MHz)

CHAN.	FREQ. (MHz)	PEAK POWER (dBm)		TOTAL POWER (mW)	TOTAL POWER (dBm)	LIMIT (dBm)	PASS / FAIL
		CHAIN 0	CHAIN 1				
149	5745	25.44	24.53	633.737	28.02	30	PASS
157	5785	25.61	24.74	661.767	28.21	30	PASS
165	5825	25.33	24.58	628.271	27.98	30	PASS

#### 802.11n (40MHz)

CHAN.	FREQ. (MHz)	PEAK POWER (dBm)		TOTAL POWER (mW)	TOTAL POWER (dBm)	LIMIT (dBm)	PASS / FAIL
		CHAIN 0	CHAIN 1				
151	5755	25.55	24.51	641.410	28.07	30	PASS
159	5795	25.58	24.51	643.898	28.09	30	PASS



**FOR AVERAGE POWER**

**802.11a**

CHANNEL	FREQUENCY (MHz)	AVG. POWER (dBm)		TOTAL POWER (mW)	TOTAL POWER (dBm)
		CHAIN 0	CHAIN 1		
149	5745	20.32	20.21	212.601	23.28
157	5785	19.94	19.78	193.688	22.87
165	5825	19.31	19.11	166.780	22.22

**802.11n (20MHz)**

CHANNEL	FREQUENCY (MHz)	AVG. POWER (dBm)		TOTAL POWER (mW)	TOTAL POWER (dBm)
		CHAIN 0	CHAIN 1		
149	5745	18.73	18.68	148.435	21.72
157	5785	19.30	19.00	164.547	22.16
165	5825	19.43	19.23	171.453	22.34

**802.11n (40MHz)**

CHANNEL	FREQUENCY (MHz)	AVG. POWER (dBm)		TOTAL POWER (mW)	TOTAL POWER (dBm)
		CHAIN 0	CHAIN 1		
151	5755	20.09	19.87	199.145	22.99
159	5795	19.46	19.37	174.805	22.43



A D T

## **5.5 POWER SPECTRAL DENSITY MEASUREMENT**

### **5.5.1 LIMITS OF POWER SPECTRAL DENSITY MEASUREMENT**

The Maximum of Power Spectral Density Measurement is 8dBm.

### **5.5.2 TEST SETUP**

Same as item 4.5.2.

### **5.5.3 TEST INSTRUMENTS**

Refer to section 4.1.2 to get information of above instrument.

### **5.5.4 TEST PROCEDURE.**

Same as item 4.5.4.

### **5.5.5 DEVIATION FROM TEST STANDARD**

No deviation.

### **5.5.6 EUT OPERATING CONDITION**

Same as item 4.3.6.





A D T

## 5.5.7 TEST RESULTS

### 802.11a

TX chain	Channel	Freq. (MHz)	PSD (dBm/3kHz)	10 log (N=2) dB	Total PSD (dBm/3kHz)	Limit (dBm/3kHz)	PASS /FAIL
0	149	5745	-7.36	3.01	-4.32	8	PASS
	157	5785	-7.70	3.01	-4.66	8	PASS
	165	5825	-9.04	3.01	-6.00	8	PASS
1	149	5745	-7.88	3.01	-4.84	8	PASS
	157	5785	-8.69	3.01	-5.65	8	PASS
	165	5825	-9.46	3.01	-6.42	8	PASS

**NOTE:** Directional gain = 2dBi + 10log(2) = 5.01dBi < 6dBi, so the limit no need to reduced.

### 802.11n (20MHz)

TX chain	Channel	Freq. (MHz)	PSD (dBm/3kHz)	10 log (N=2) dB	Total PSD (dBm/3kHz)	Limit (dBm/3kHz)	PASS /FAIL
0	149	5745	-8.60	3.01	-5.56	8	PASS
	157	5785	-8.94	3.01	-5.90	8	PASS
	165	5825	-8.52	3.01	-5.48	8	PASS
1	149	5745	-7.89	3.01	-4.85	8	PASS
	157	5785	-8.61	3.01	-5.57	8	PASS
	165	5825	-9.64	3.01	-6.60	8	PASS

**NOTE:** Directional gain = 2dBi + 10log(2) = 5.01dBi < 6dBi, so the limit no need to reduced.

### 802.11n (40MHz)

TX chain	Channel	Freq. (MHz)	PSD (dBm/3kHz)	10 log (N=2) dB	Total PSD (dBm/3kHz)	Limit (dBm/3kHz)	PASS /FAIL
0	151	5755	-10.17	3.01	-7.12	8	PASS
	159	5795	-4.85	3.01	-1.80	8	PASS
1	151	5755	-10.07	3.01	-7.02	8	PASS
	159	5795	-11.76	3.01	-8.71	8	PASS

**NOTE:** Directional gain = 2dBi + 10log(2) = 5.01dBi < 6dBi, so the limit no need to reduced.



A D T

## **5.6 CONDUCTED OUT OF BAND EMISSION MEASUREMENT**

### **5.6.1 LIMITS OF CONDUCTED OUT OF BAND EMISSION MEASUREMENT**

Below  $-20\text{dB}$  of the highest emission level of operating band (in 100kHz Resolution Bandwidth).

### **5.6.2 TEST SETUP**

Same as Item 4.6.2

### **5.6.3 TEST INSTRUMENTS**

Refer to section 4.1.2 to get information of above instrument.

### **5.6.4 TEST PROCEDURE**

Same as Item 4.6.4

### **5.6.5 DEVIATION FROM TEST STANDARD**

No deviation.

### **5.6.6 EUT OPERATING CONDITION**

Same as Item 4.3.6

### **5.6.7 TEST RESULTS**

The conducted emission test is performed on each TX port of operating mode without summing or adding  $10\log(N)$  since the limit is relative emission limit.

The spectrum plots are attached on the following pages. D1 line indicates the highest level, and D2 line indicates the 20dB offset below D1. It shows compliance with the requirement.



A D T

802.11a  
CHAIN 0

CH 149

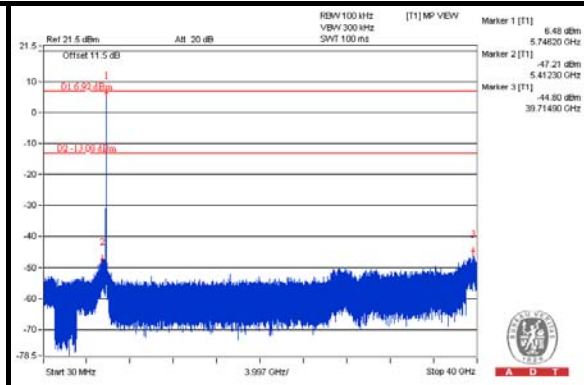
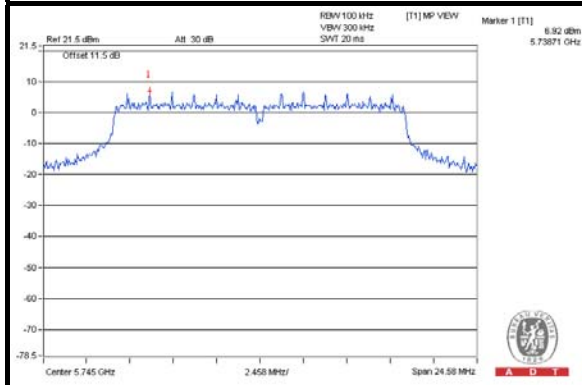

CH 157

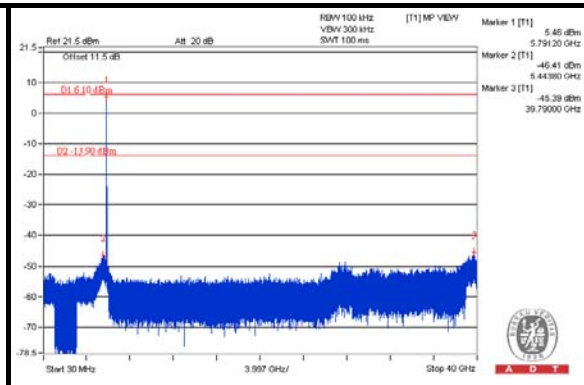
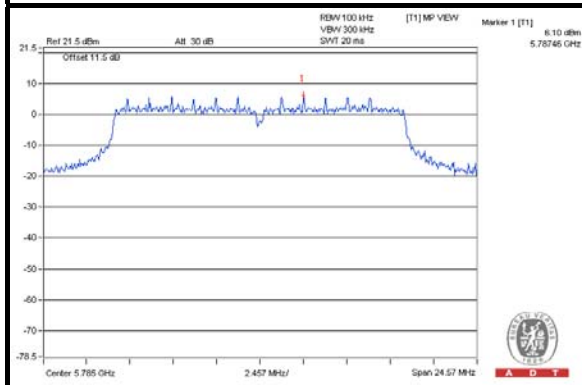

CH 165

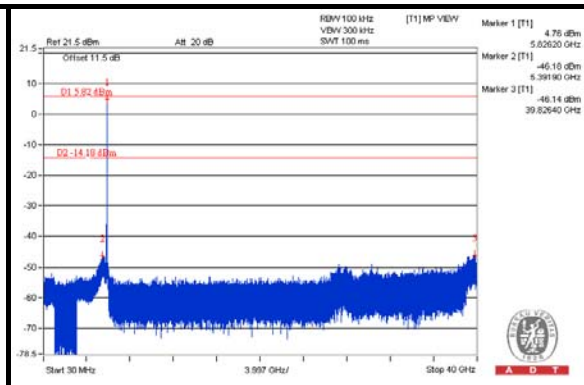
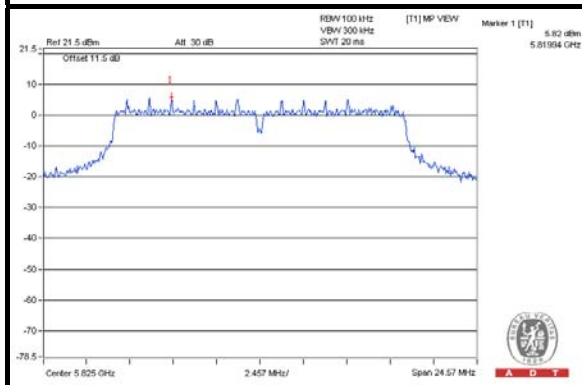

CH 149 Band edge

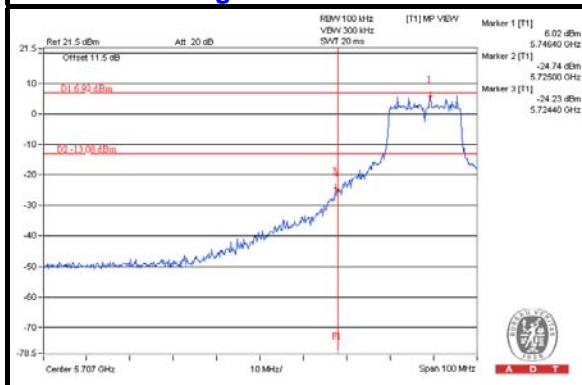

CH 165 Band edge

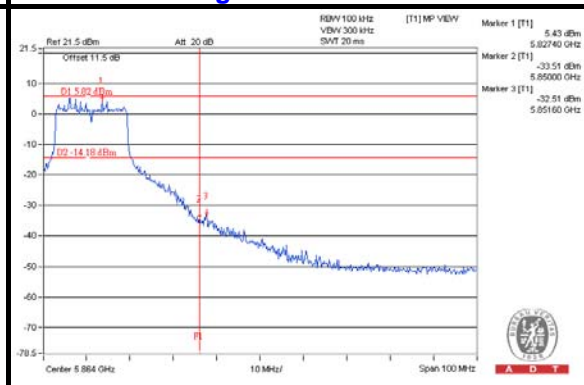



A D T

### CHAIN 1

#### CH 149

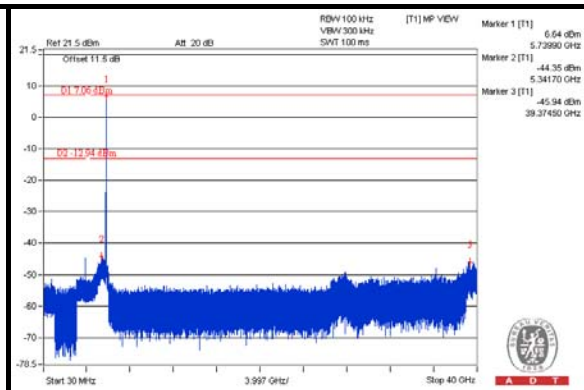
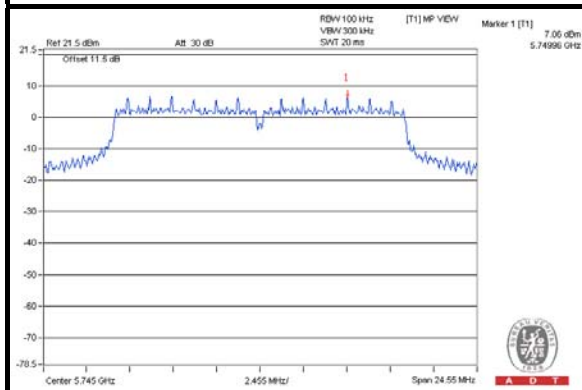

#### CH 157

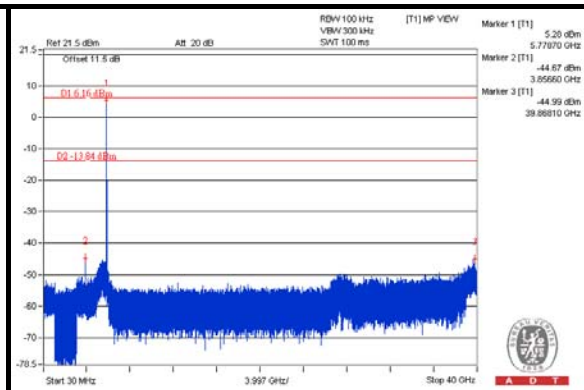
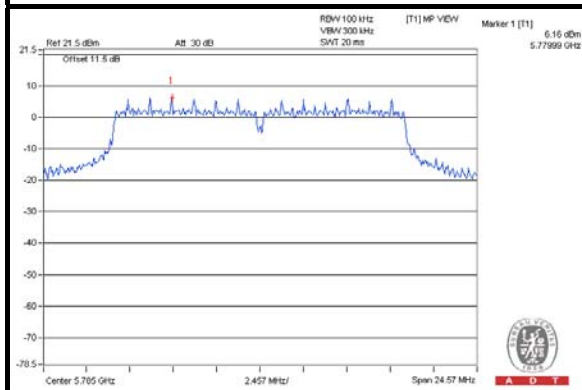

#### CH 165

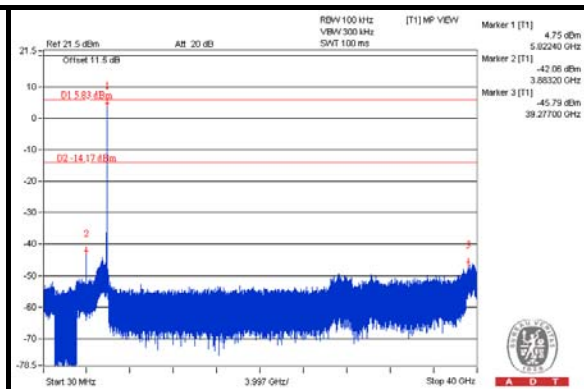
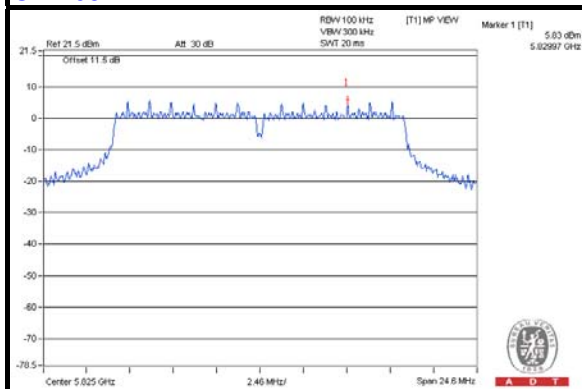

#### CH 149 Band edge

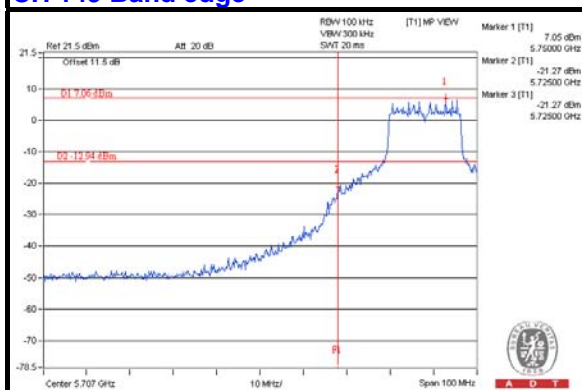

#### CH 165 Band edge

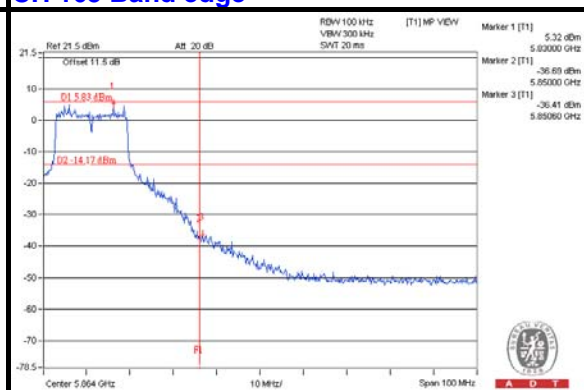



A D T

### 802.11n (20MHz)

### CHAIN 0

### CH 149

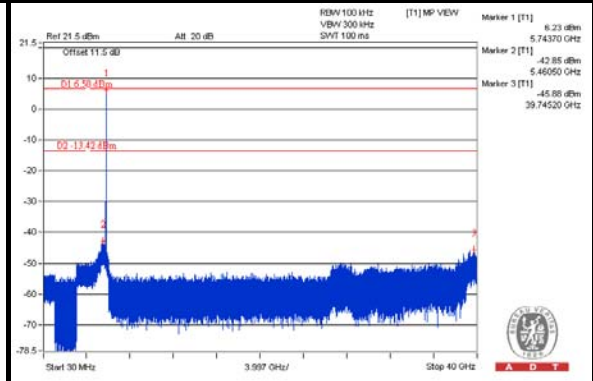
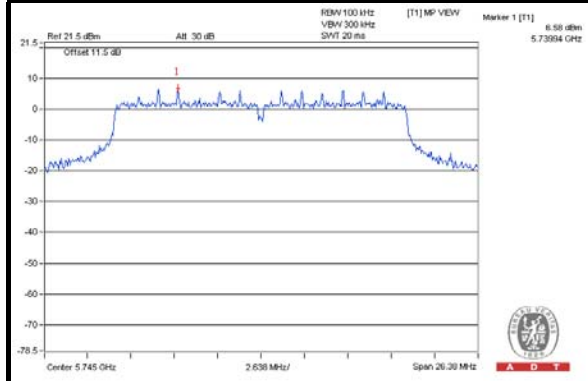

### CH 157

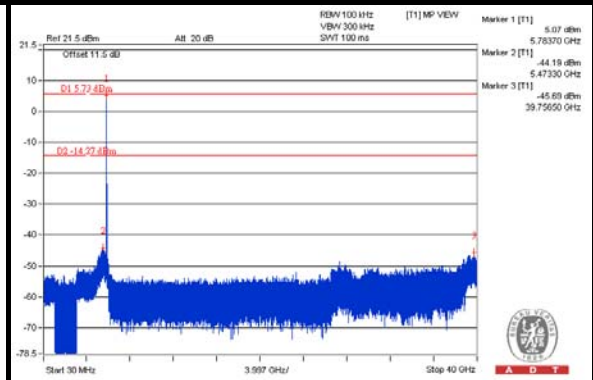
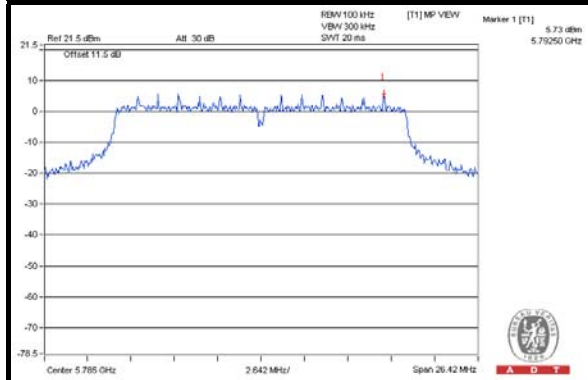

### CH 165

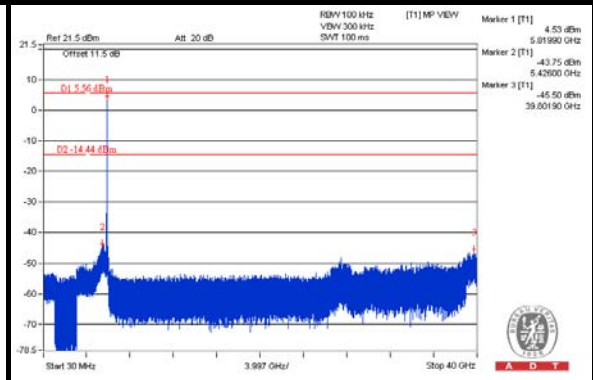
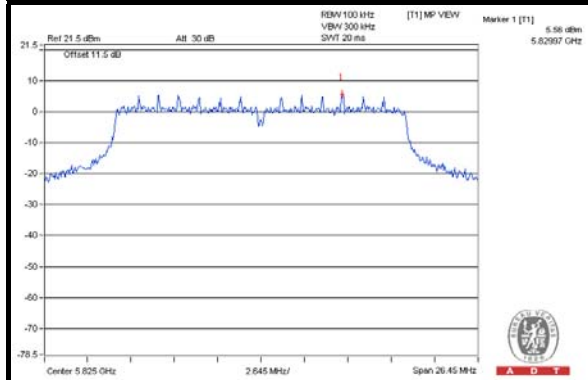

### CH 149 Band edge

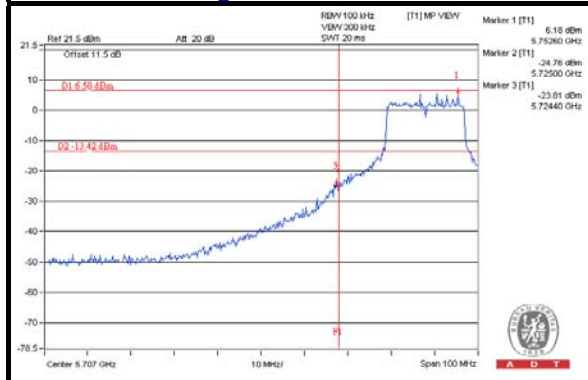

### CH 165 Band edge

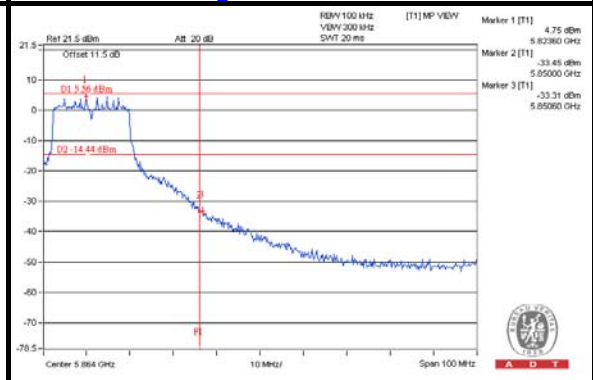



A D T

### CHAIN 1

#### CH 149

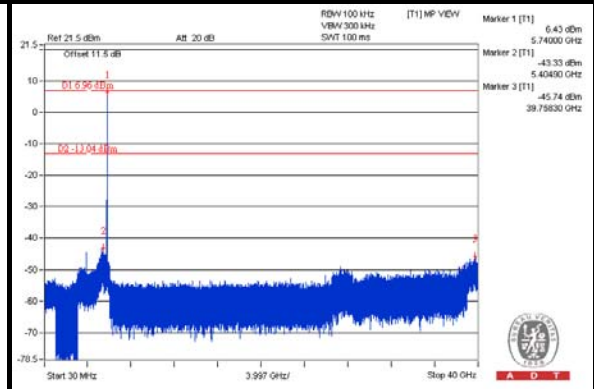
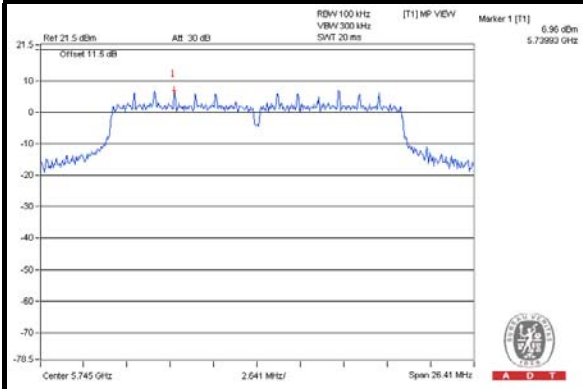

#### CH 157

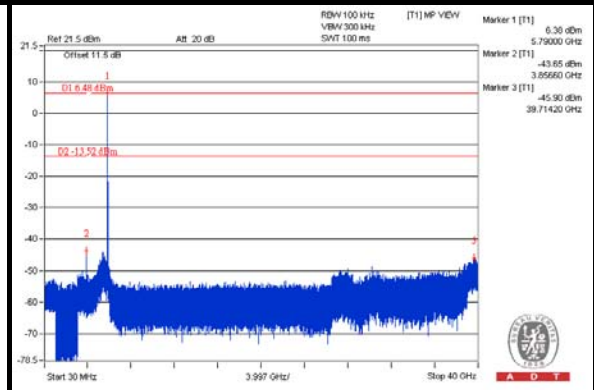
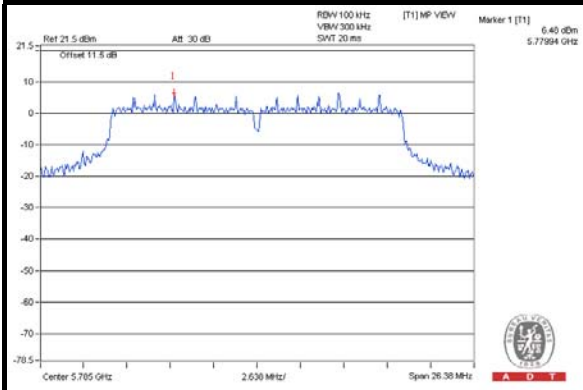

#### CH 165

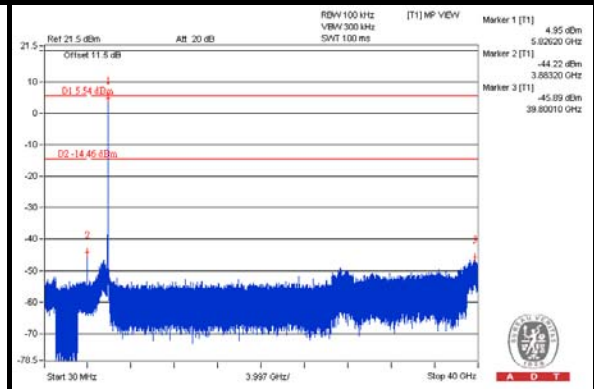
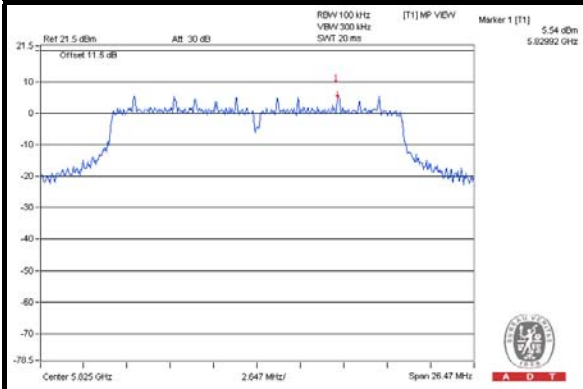

#### CH 149 Band edge

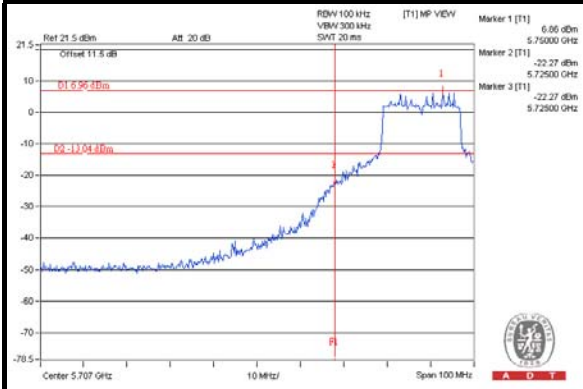

#### CH 165 Band edge

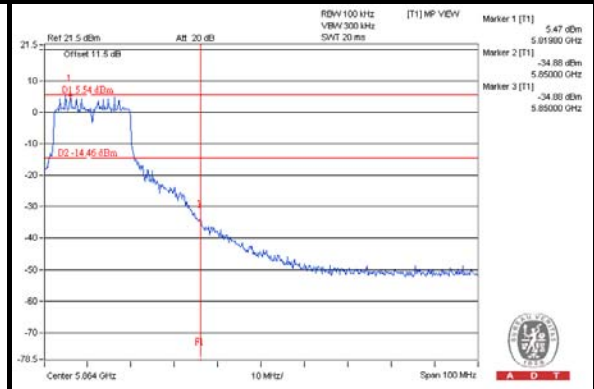



A D T

### 802.11n (40MHz)

### CHAIN 0

#### CH 151

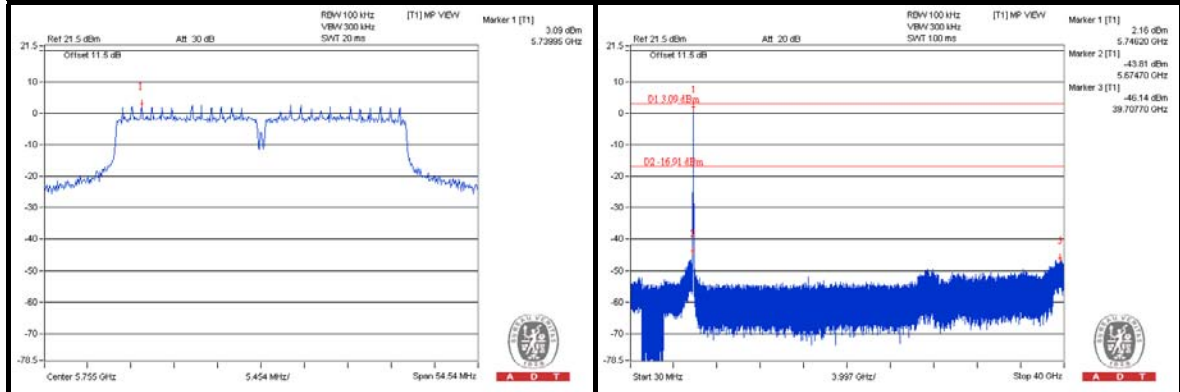

#### CH 159

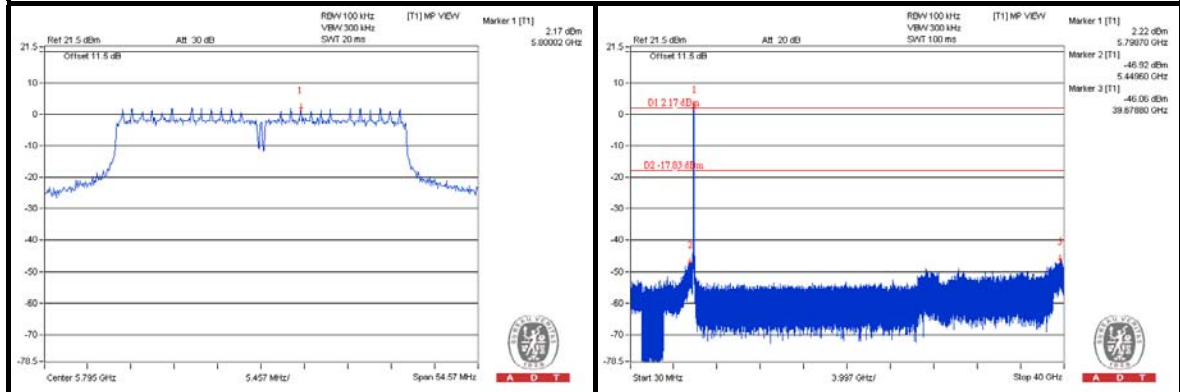

#### CH 151 Band edge

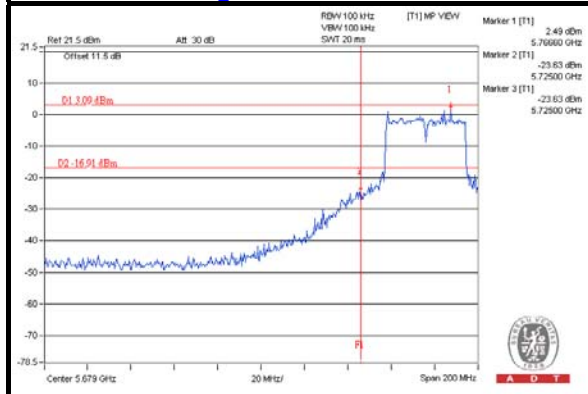

#### CH 159 Band edge

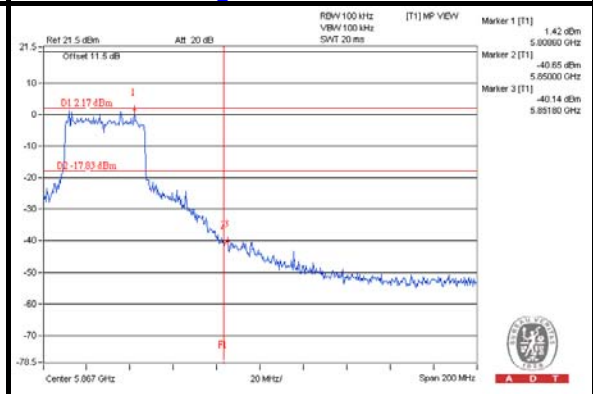



A D T

### CHAIN 1

#### CH 151

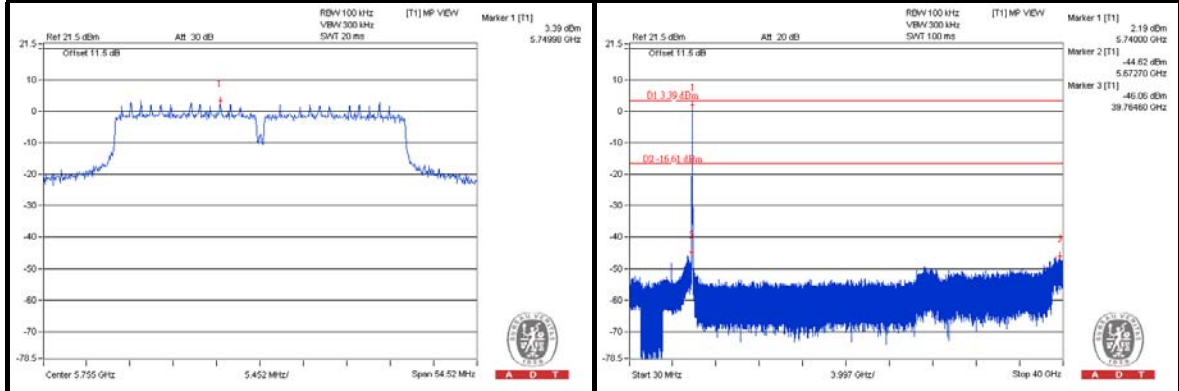

#### CH 159

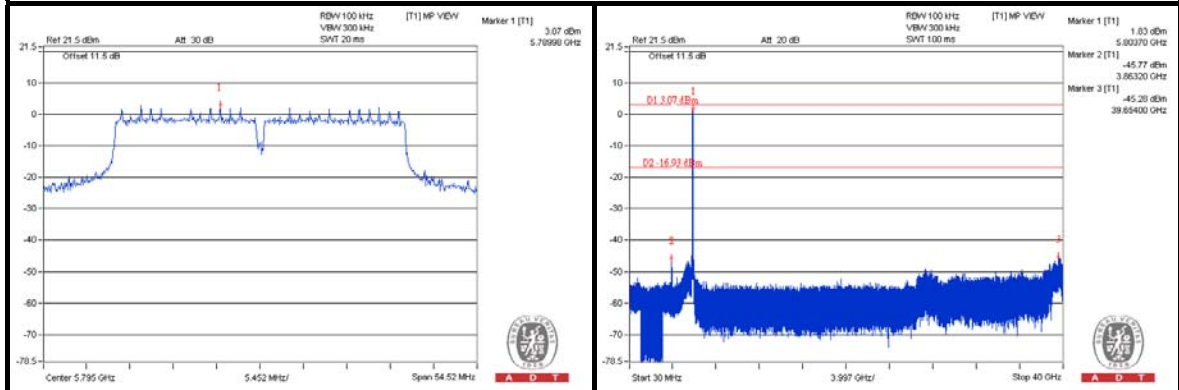

#### CH 151 Band edge

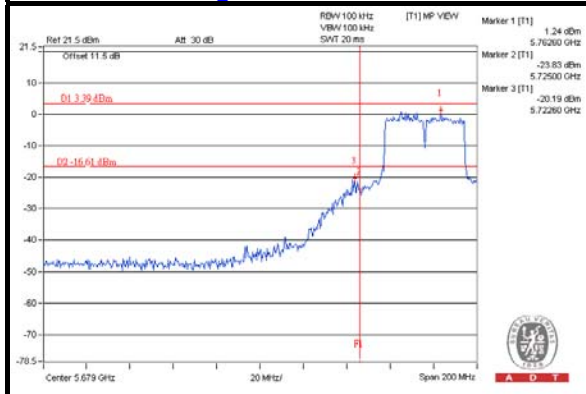

#### CH 159 Band edge

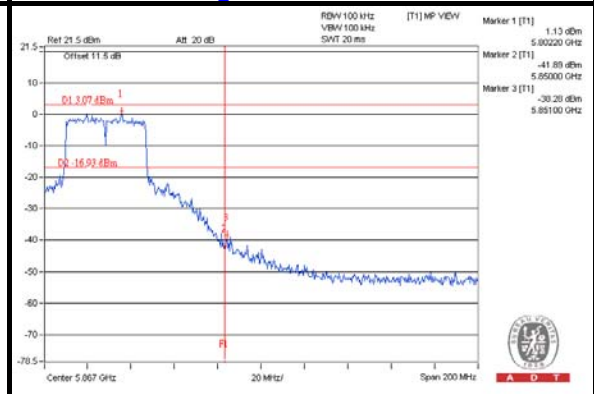





A D T

## 6. PHOTOGRAPHS OF THE TEST CONFIGURATION

Please refer to the attached file (Test Setup Photo).



A D T

## 7. INFORMATION ON THE TESTING LABORATORIES

We, Bureau Veritas Consumer Products Services (H.K.) Ltd., Taoyuan Branch, were founded in 1988 to provide our best service in EMC, Radio, Telecom and Safety consultation. Our laboratories are accredited and approved according to ISO/IEC 17025.

If you have any comments, please feel free to contact us at the following:

**Linko EMC/RF Lab**

Tel: 886-2-26052180

Fax: 886-2-26051924

**Hsin Chu EMC/RF Lab**

Tel: 886-3-5935343

Fax: 886-3-5935342

**Hwa Ya EMC/RF/Safety/Telecom Lab**

Tel: 886-3-3183232

Fax: 886-3-3270892

**Email:** [service.adt@tw.bureauveritas.com](mailto:service.adt@tw.bureauveritas.com)

**Web Site:** [www.bureauveritas-adt.com](http://www.bureauveritas-adt.com)

The address and road map of all our labs can be found in our web site also.



A D T

## **8. APPENDIX A – MODIFICATIONS RECORDERS FOR ENGINEERING CHANGES TO THE EUT BY THE LAB**

No modifications were made to the EUT by the lab during the test.

**---END---**